Part 3 – Standards & Guidelines



The Secretary of the Interior's Standards for the Treatment of Historic Properties

Note: the Ann Arbor Historic District Commission uses only the Standards for Rehabilitation.

<https://www.nps.gov/orgs/1739/secretary-standards-treatment-historic-properties.htm>

The Secretary of the Interior's Standards: Rehabilitation as a Treatment and Standards for Rehabilitation

Note: Standards for Preservation and Guidelines for Preserving Historic Buildings have been removed from this document.

The full publication is available online here: <https://www.nps.gov/orgs/1739/upload/treatment-guidelines-2017-part1-preservation-rehabilitation.pdf>

Illustrated Guidelines on Sustainability for Rehabilitating Historic Buildings

City of Ann Arbor HDC Historic District Design Guidelines

Ann Arbor HDC Guardrail and Handrail Guidelines

Ann Arbor Historic District Sign Guidelines

Ann Arbor HDC Design Guidelines for Solar Panels

Ann Arbor HDC Guidelines for Window Evaluation, Repair, and Replacement

Bylaws of the Ann Arbor Historic District Commission

Code of Ordinances Chapter 8 – Organization of Boards and Commissions

Code of Ordinances 108 – Historic Preservation



THE SECRETARY
OF THE INTERIOR'S
**STANDARDS FOR
THE TREATMENT
OF HISTORIC
PROPERTIES**

WITH
**GUIDELINES FOR
PRESERVING,
REHABILITATING,
RESTORING &
RECONSTRUCTING
HISTORIC
BUILDINGS**



U.S. Department of the Interior
National Park Service
Technical Preservation Services

Under the National Historic Preservation Act (NHPA), the Secretary of the Interior is responsible for establishing professional standards and for providing guidance on the preservation of the nation's historic properties. *The Secretary of the Interior's Standards for the Treatment of Historic Properties* apply to all grants-in-aid projects assisted through the Historic Preservation Fund (authorized by the NHPA) and are intended to be applied to a wide variety of resource types, including buildings, sites, structures, objects, and districts. The Standards address four treatments: preservation, rehabilitation, restoration, and reconstruction. The treatment Standards, developed in 1992, were codified as 36 CFR Part 68 in the July 12, 1995, Federal Register (Vol. 60, No. 133). They replaced the 1978 and 1983 versions of 36 CFR Part 68, entitled *The Secretary of the Interior's Standards for Historic Preservation Projects*. The revised Guidelines herein replace the Guidelines for Preserving, Rehabilitating, Restoring, and Reconstructing Historic Buildings, published in 1995 to accompany the treatment Standards.

The Secretary of the Interior's Standards for the Treatment of Historic Properties are regulatory only for projects receiving Historic Preservation Fund grant assistance and other federally-assisted projects. Otherwise, these Guidelines are intended to provide general guidance for work on any historic building.

Another regulation, 36 CFR Part 67, focuses on "certified historic structures" as defined by the Internal Revenue Service Code of 1986. The Standards for Rehabilitation cited in 36 CFR Part 67 should always be used when property owners are seeking certification for federal tax benefits.

THE SECRETARY OF THE INTERIOR'S **STANDARDS**
FOR THE TREATMENT OF HISTORIC PROPERTIES
WITH
GUIDELINES FOR PRESERVING, REHABILITATING,
RESTORING & RECONSTRUCTING HISTORIC BUILDINGS

Revised by Anne E. Grimmer

*from The Secretary of the Interior's Standards
for the Treatment of Historic Properties with
Guidelines for Preserving, Rehabilitating,
Restoring & Reconstructing Historic Buildings
Kay D. Weeks and Anne E. Grimmer (1995)*

U.S. Department of the Interior
National Park Service
Technical Preservation Services
Washington, D.C.

2017

CONTENTS

IV PHOTO CREDITS

VI ACKNOWLEDGEMENTS

VII PREFACE

2 INTRODUCTION

Using the Standards and Guidelines for a Preservation, Rehabilitation, Restoration, or Reconstruction Project

Choosing an Appropriate Treatment for the Historic Building

4 HISTORICAL OVERVIEW

Building Materials

Masonry • Wood • Metals

Building Features and Systems

Roofs • Windows • Entrances and Porches • Storefronts • Curtain Walls • Structural Systems • Mechanical Systems

Interior Spaces, Features, and Finishes

Building Site

Setting (District/Neighborhood)

Code-Required Work:

Accessibility • Life Safety

Resilience to Natural Hazards

Sustainability

New Exterior Additions to Historic Buildings and Related New Construction

27 STANDARDS FOR PRESERVATION & GUIDELINES FOR PRESERVING HISTORIC BUILDINGS

29 INTRODUCTION

31 BUILDING MATERIALS

31 Masonry

37 Wood

41 Metals

44 BUILDING FEATURES AND SYSTEMS

44 Roofs

46 Windows

49 Entrances and Porches

51 Storefronts

53 Curtain Walls

55 Structural Systems

58 Mechanical Systems

Note:

Standards for Preservation and Guidelines for Preserving Historic Buildings have been removed from this document. The full publication is available for viewing online.

60 INTERIOR SPACES, FEATURES,
AND FINISHES

63 BUILDING SITE

66 SETTING (DISTRICT/NEIGHBORHOOD)

69 CODE-REQUIRED WORK

69 Accessibility

71 Life Safety

72 RESILIENCE TO NATURAL HAZARDS

74 SUSTAINABILITY

75 STANDARDS FOR REHABILITATION
& GUIDELINES FOR REHABILITATING
HISTORIC BUILDINGS

77 INTRODUCTION

80 BUILDING MATERIALS

80 Masonry

88 Wood

93 Metals

98 BUILDING FEATURES AND SYSTEMS

98 Roofs

102 Windows

110 Entrances and Porches

113 Storefronts

117 Curtain Walls

121 Structural Systems

125 Mechanical Systems

128 INTERIOR SPACES, FEATURES, AND FINISHES

137 BUILDING SITE

143 SETTING (DISTRICT/NEIGHBORHOOD)

147 CODE-REQUIRED WORK

147 Accessibility

150 Life Safety

153 RESILIENCE TO NATURAL HAZARDS

155 SUSTAINABILITY

156 NEW EXTERIOR ADDITIONS TO HISTORIC
BUILDINGS AND RELATED NEW
CONSTRUCTION

163 STANDARDS FOR RESTORATION
& GUIDELINES FOR RESTORING
HISTORIC BUILDINGS

165 INTRODUCTION

Contents Restoration (cont.)

168 MATERIALS

168 Masonry

176 Wood

180 Metals

184 BUILDING FEATURES AND SYSTEMS

184 Roofs

187 Windows

190 Entrances and Porches

193 Storefronts

196 Curtain Walls

199 Structural Systems

202 Mechanical Systems

204 INTERIOR SPACES, FEATURES, AND FINISHES

209 BUILDING SITE

214 SETTING (DISTRICT/NEIGHBORHOOD)

218 CODE-REQUIRED WORK

218 Accessibility

220 Life Safety

222 RESILIENCE TO NATURAL HAZARDS

224 SUSTAINABILITY

225 STANDARDS FOR RECONSTRUCTION & GUIDELINES FOR RECONSTRUCTING HISTORIC BUILDINGS

227 INTRODUCTION

230 OVERVIEW

232 BUILDING EXTERIOR

234 BUILDING INTERIOR

236 BUILDING SITE

238 BUILDING SETTING (DISTRICT/NEIGHBORHOOD)

PHOTO CREDITS

Front Cover: Spooner Hall, University of Kansas, Lawrence, KS, Henry van Brunt, 1894.

HISTORICAL OVERVIEW

Masonry. Detail, decorative sandstone door surround.

Wood. Detail, Pope-Leighey House, Alexandria, VA, Frank Lloyd Wright, 1940. Photo: Courtesy National Trust for Historic Preservation, Paul Burk, photographer.

Metals. Detail, Dunbar Molasses Factory, New Orleans, LA, c. 1920.

Glass. Detail, St. John's Abbey, Collegeville, MN, Marcel Breuer, 1958-61.

Paint and Other Coatings. Interior detail, Mabel Tainter Memorial Theater, Menomonie, WI, Harvey Ellis, 1889. Photo: Miller Dunwiddie Architecture.

Composite Materials. Composite siding, Private Residence, Washington, DC, William Lescaze, 1940.

Simulative Materials. Detail, wood used to simulate cut stone.

Roofs. Asphalt roof shingles on a 1920s-era house.

Windows. Paired wood windows with stained glass lunette on a Romanesque revival-style rowhouse.

Entrances and Porches. Decorative stone entrance with etched-glass revolving door on early-20th century office building.

Storefronts. Ellicott City, MD.

Curtain Walls. Simms Building, Albuquerque, NM, Flatow & Moore, 1954. Photo: Harvey M. Kaplan.

Structural Systems. Boiler Maker Shops, Navy Yard Annex, Washington, DC, 1919.

Mechanical Systems. Historic Radiator.

Spaces, Features, and Finishes. Interior, Saenger Theater, New Orleans, LA, Emile Weil, 1927. Photo: Courtesy Saenger Theater.

Site. Vineyard, Charles Krug Winery, St. Helena, CA. Photo: Rocco Ceselin. Inset: Redwood Cellar, 1872, Charles Krug Winery. Photo: Rien van Rijthoven.

Setting. Late-19th-century residential historic district.

Accessibility. Gradual slope added to sidewalk and paving for accessibility. Schmidt Brewery, St. Paul, MN, late 19th-early 20th century.

Life Safety. Code-required, supplemental stair railing.

Resilience to Natural Hazards. Farnsworth House, Plano, IL, Mies van der Rohe, 1951. Photo: Courtesy Farnsworth, A Site of the National Trust for Historic Preservation.

Sustainability. Traditional sustainable features include deep porches and window shutters in southern architecture.

New Additions and Related New Construction. Private Residence, Washington, DC, Cunningham/Quill Architects. Photo: © Maxwell MacKenzie.

CHAPTER HEADS

Preservation. Old Santa Fe Trail Building (National Park Service Intermountain Regional Office), Santa Fe, NM. This adobe building was designed by John Gaw Meem in the Spanish-Pueblo Revival style, and constructed for the National Park Service through the auspices of the Civilian Conservation Corps (CCC) and the Works Project Administration (WPA) in 1939. Photo: MRWM Landscape Architects.

Rehabilitation. The Arcade, Providence, RI, 1828. Photo: Northeast Collaborative Architects, Ben Jacobson, photographer.

Restoration. Montpelier, Montpelier Station, VA. National Trust for Historic Preservation, Administered by The Montpelier Foundation. Photo: Courtesy The Montpelier Foundation.

Reconstruction. The Cathedral of Saint Michael the Archangel, Sitka, AK, built early 1840s, reconstructed 1961. Photo: Barek at Wikimedia Commons.

Photographs not individually credited are from National Park Service files.

ACKNOWLEDGEMENTS

This edition of *The Secretary of the Interior's Standards for the Treatment of Historic Properties with Guidelines for Preserving, Rehabilitating, Restoring and Reconstructing Historic Buildings* has been produced in part to ensure that the National Park Service continues to fulfill its responsibility to promote the preservation of the historic buildings that are part of the nation's cultural heritage. This has been a collaborative effort undertaken by the office of Technical Preservation Services (TPS) in the National Park Service, with the assistance of other National Park Service programs, State Historic Preservation Offices (SHPO), the Advisory Council on Historic Preservation, Federal Agency Historic Preservation Officers, the National Trust for Historic Preservation, and others. The comments and suggestions provided by these agencies and organizations, together with important contributions from the TPS professional staff, have been invaluable in the development of this revised and updated guidance on preserving, rehabilitating, restoring, and reconstructing historic buildings that accompany *The Secretary of the Interior's Standards for the Treatment of Historic Properties*.

PREFACE

The year 2016 was significant as the Centennial of the National Park Service, which was established as a new bureau within the Department of the Interior by the Organic Act on August 25, 1916. As directed in this legislation, the National Park Service has served for one hundred years as steward of the “Federal areas known as national parks, monuments and reservations...to conserve the scenery and the natural and historic objects and the wild life therein and to...leave them unimpaired for the enjoyment of future generations.”

The year 2016 also marked the 50th anniversary of the passage of the National Historic Preservation Act on October 15, 1966. The Act increased the scope and responsibilities of the National Park Service with regard to the preservation of cultural resources. The National Historic Preservation Act charges the National Park Service (through authority delegated by the Secretary of the Interior) to establish and administer a national historic preservation program and to develop and promulgate standards and guidelines for the treatment of historic properties.

The Secretary of the Interior’s Standards for Historic Preservation Projects were first issued in 1978. In 1979 they were published with *Guidelines for Applying the Standards* and reprinted in 1985. The Standards were revised in 1992, when they were retitled *The Secretary of the Interior’s Standards for the Treatment of Historic Properties*.

The Standards were codified in the Federal Register in 1995, the same year that they were published with guidelines as *The Secretary of the Interior’s Standards for the Treatment of Historic Properties with Guidelines for Preserving, Rehabilitating, Restoring and Reconstructing Historic Buildings*. These Standards and Guidelines provide a critical part of the framework of the national preservation program. They are widely used at the federal, state, and local levels to guide work on historic buildings, and they also have been adopted by Certified Local Governments and historic preservation commissions across the nation.

In 2010 the National Park Service issued *A Call to Action: Preparing for a Second Century of Stewardship and Engagement*, a plan to chart a path for its next 100 years. This plan identified a number of actions with the goal to “preserve America’s special places in the next century,” which included updating National Park Service policies and guidance. The project to update *The Secretary of the Interior’s Standards for the Treatment of Historic Properties with Guidelines for Preserving, Rehabilitating, Restoring and Reconstructing Historic Buildings* was undertaken as part of this broader effort.

Since these Guidelines were first published in 1995, a greater number of buildings and building types, telling a broader range of stories that are part of the nation’s heritage, have been recognized as “historic”

and eligible for listing in the National Register of Historic Places. These guidelines have been updated and expanded to address the treatment of these buildings constructed with newer materials and systems from the mid- and late-20th century.

The updated Guidelines have the same organization as the prior version, beginning with an introduction and a historical overview, followed by chapters that focus on each of the four treatments: preservation, rehabilitation, restoration, and reconstruction. The historical overview has been expanded; not only has the information on historic materials, systems, features, and special issues that comprised the previous edition been more fully developed, but new entries have been added on glass, paint and other coatings, composite materials, imitative materials, and curtain walls.

In each of the four chapters, the “Recommended” and “Not Recommended” treatments have been updated and revised throughout to ensure that they continue to promote the best practices in preservation. The section on exterior additions to historic buildings in the Rehabilitation Guidelines has been broadened also to address related new construction on a building site. A section on code-required work is now included in all of the chapters. “Energy Efficiency” has been eliminated, since it is more fully covered by the guidance provided on sustainability in *The Secretary of the Interior’s Standards for Rehabilitation and Illustrated Guidelines on Sustainability*

for Rehabilitating Historic Buildings (published in 2011), which has general applicability to all the treatments and is incorporated here by reference. Sections on “Resilience to Natural Hazards” have been added, but these topics will be more fully addressed in separate documents and web features. Finally, the updated Guidelines feature all new, and many more, illustrations in color.

Herewith Technical Preservation Services issues the National Park Service Centennial edition of *The Secretary of the Interior’s Standards for the Treatment of Historic Properties with Guidelines for Preserving, Rehabilitating, Restoring and Reconstructing Historic Buildings*, updated and revised in recognition of the 50th anniversary of the National Historic Preservation Act, to ensure that the preservation guidance for historic buildings provided by the National Park Service continues to be meaningful and relevant in the 21st century.

*Technical Preservation Services
National Park Service*

Technical Preservation Services National Park Service

The office of Technical Preservation Services (TPS) in the Cultural Resources directorate of the National Park Service is responsible for developing and promulgating preservation standards and guidance specifically as it relates to historic buildings. TPS has produced an extensive amount of technical, educational, and policy guidance on the maintenance and preservation of historic buildings. TPS developed the original and current versions of *The Secretary of the Interior's Standards for the Treatment of Historic Properties with Guidelines for Preserving, Rehabilitating, Restoring and Reconstructing Historic Buildings*. The many technical publications and web features on preserving historic buildings prepared by TPS are well known, especially the *Preservation Briefs* and the *Preservation Tech Notes* series. It is not feasible to include a complete list here of all the materials available from TPS because of the sheer volume of information. Materials developed by TPS are available in printed form and/or online from the TPS website at <https://www.nps.gov/tps> (or search for Technical Preservation Services at <https://www.nps.gov>). TPS also administers the Federal Historic Preservation Tax Incentives Program, which encourages private sector investment in the rehabilitation and reuse of historic buildings.

INTRODUCTION

Using the Standards and Guidelines for Preservation, Rehabilitation, Restoration, and Reconstruction Projects

The Secretary of the Interior's Standards for the Treatment of Historic Properties address four treatments: preservation, rehabilitation, restoration, and reconstruction. As stated in the regulations (36 CFR Part 68) promulgating the Standards, "one set of standards ...will apply to a property undergoing treatment, depending upon the property's significance, existing physical condition, the extent of documentation available, and interpretive goals, when applicable. The Standards will be applied taking into consideration the economic and technical feasibility of each project." These Standards apply not only to historic buildings but also to a wide variety of historic resource types eligible to be listed in the National Register of Historic Places. This includes buildings, sites, structures, objects, and districts.

Guidelines, however, are developed to help apply the Standards to a specific type of historic resource. Thus, in addition to these Guidelines for Preserving, Rehabilitating, Restoring and Reconstructing Historic Buildings, there are also guidelines for cultural landscapes, historic lighthouses, historic vessels, historic furnished interiors, and historic covered bridges.

The purpose of *The Secretary of the Interior's Standards for the Treatment of Historic Properties and Guidelines for Preserving, Rehabilitating, Restoring and Reconstructing Historic Buildings* is to provide guidance to historic building owners and building managers, preservation consultants, architects, contractors, and project reviewers prior to beginning work. It is always recommended that preservation professionals be consulted early in any project.

The Guidelines are intended as an aid to assist in applying the Standards to all types of historic buildings. They are not meant to give case-specific advice or address exceptions or unusual conditions.

They address both exterior and interior work on historic buildings. Those approaches to work treatments and techniques that are consistent with The Secretary of the Interior's Standards for the Treatment of Historic Properties are listed in the "Recommended" column on the left; those which are inconsistent with the Standards are listed in the "Not Recommended" column on the right.

There are four sections, each focusing on one of the four treatment Standards: Preservation, Rehabilitation, Restoration, and Reconstruction. Each section includes one set of Standards with accompanying Guidelines that are to be used throughout the course of a project.

Preservation is defined as the act or process of applying measures necessary to sustain the existing form, integrity, and materials of an historic property. Work, including preliminary measures to protect and stabilize the property, generally focuses upon the ongoing maintenance and repair of historic materials and features rather than extensive replacement and new construction. The limited and sensitive upgrading of mechanical, electrical, and plumbing systems and other code-required work to make properties functional is appropriate within a preservation project. However, new exterior additions are not within the scope of this treatment. The Standards for Preservation require retention of the greatest amount of historic fabric along with the building's historic form.

Rehabilitation is defined as the act or process of making possible a compatible use for a property through repair, alterations, and additions while preserving those portions or features which convey its historical, cultural, or architectural values. The Rehabilitation Standards acknowledge the need to alter or add to a historic building to meet continuing or new uses while retaining the building's historic character.

Restoration is defined as the act or process of accurately depicting the form, features, and character of a property as it appeared at a particular period of time by means of the removal of features from other periods in its history and reconstruction of missing features from the restoration period. The limited and sensitive upgrading of mechanical, electrical, and plumbing systems and other code-required work to make properties functional is appropriate within a restoration project. The Restoration Standards allow for the depiction of a building at a particular time in its history by preserving materials, features, finishes, and spaces from its period of significance and removing those from other periods.

Reconstruction is defined as the act or process of depicting, by means of new construction, the form, features, and detailing of a non-surviving site, landscape, building, structure, or object for the purpose of replicating its appearance at a specific period of time and in its historic location. The Reconstruction Standards establish a limited framework for recreating a vanished or non-surviving building with new materials, primarily for interpretive purposes.

The Guidelines are introduced with a brief overview of the primary materials used in historic buildings; the exterior and interior architectural features and systems; the building's site and setting; code-compliance requirements regarding accessibility and life-safety resilience to natural hazards; sustainability; and new additions and related new construction. This overview establishes the format of the Guidelines that follow.

Choosing an Appropriate Treatment for the Historic Building

The Guidelines are intended to promote responsible preservation practices that help protect the nation's irreplaceable cultural resources. For example, they cannot, in and of themselves, be used to make essential decisions about which features of the historic building should be saved and which can be changed. But, once a treatment is selected, the Standards and Guidelines provide a consistent philosophical approach to the work.

Choosing the most appropriate treatment for a building requires careful decision making about a building's historical significance, as well as taking into account a number of other considerations:

Level of Significance. National Historic Landmarks, designated for their "exceptional significance in American history," and other properties important for their interpretive value may be candidates for *Preservation* or *Restoration*. *Rehabilitation*, however, is the most commonly used treatment for the majority of historic buildings. *Reconstruction* has the most limited application because so few resources that are no longer extant can be documented to the degree necessary to accurately recreate the property in a manner that conveys its appearance at a particular point in history.

Physical condition. *Preservation* may be appropriate if distinctive materials, features, and spaces are essentially intact and convey the building's historical significance. If the building requires more extensive repair and replacement, or if alterations or a new addition are necessary for a new use, then *Rehabilitation* is probably the most appropriate treatment.

Proposed use. Many historic buildings can be adapted for a new use or updated for a continuing use without seriously impacting their historic character. However, it may be very difficult or impossible to convert some special-use properties for new uses without major alterations, resulting in loss of historic character and even integrity.

Code and other regulations. Regardless of the treatment, regulatory requirements must be addressed. But without a sensitive design approach such work may damage a building's historic materials and negatively impact its character. Therefore, because the ultimate use of the building determines what requirements will have to be met, some potential uses of a historic building may not be appropriate if the necessary modifications would not preserve the building's historic character. This includes adaptations to address natural hazards as well as sustainability.

HISTORICAL OVERVIEW

Masonry

Stone is one of the more lasting masonry building materials and has been used throughout the history of American building construction. Stones most commonly used in historic buildings in the U.S. are quarried stone, including sandstone, limestone, marble, granite, slate, basalt, and coral stone, and gathered stone, such as fieldstone,

river rock, and boulders. Types of stone differ considerably in hardness, durability, and other qualities. Building stones were usually laid with mortar, but sometimes they were laid without mortar using a dry-stack method of construction. Brick varies in size and permanence. Before 1870, brick clays were pressed into molds and were often unevenly fired. The quality of historic brick depended on the type of clay available and the brick-making technique; by the 1870s, with the perfection of an extrusion process, bricks became more uniform and durable. *Architectural terra cotta* is also a kiln-fired clay product popular from the late 19th century until the 1930s. Its use became more widespread with the development of steel-frame, high-rise office buildings in the early 20th century. *Glazed ceramic architectural siding* was also used as cladding in high-rise buildings somewhat later. *Adobe*, which consists of sun-dried earthen bricks, was one of the earliest building materials used in the U.S., primarily in the Southwest where it is still popular.

Mortar is used to bond together masonry units. Historic mortar was generally quite

soft, consisting primarily of lime and sand with other additives. Portland cement, which creates a more rigid mortar, was first manufactured in the U.S. in the early 1870s, but it was not in common use throughout the country until the early 20th century. Thus, mortar used in buildings from around 1873 until the 1930s ranged from a traditional lime-cement mix to a variety of sand and Portland cement combinations. After this time, most mortar mixes were based on Portland cement. Like historic mortar, early *stucco* was also heavily lime based, increasing in hardness with the addition of Portland cement in the late 19th century.

Concrete has a long history. It is composed of sand, crushed stone, or gravel bound together with lime and, sometimes, natural hydraulic cements. As a construction material concrete is used in a variety of forms, including blocks or units, poured or cast-in-place, and precast panels. *Cast stone* and other manufactured products began to be used around the 1860s as substitutes for natural stone. There are also cementitious materials specific to certain regions, such as *tabby*, which includes crushed shells and is found primarily in coastal areas in the southeastern part of the country. In the 20th century, *reinforced concrete* was developed and has since become one of the most commonly used materials in modern building construction.

While masonry is one of the most durable historic building materials, it is also very susceptible to damage by exposure, improper maintenance or repairs, abrasive cleaning, or the application of non-permeable coatings.



Wood

Wood is one of the most essential materials used in American buildings of every period and style. Its many and varied attributes make it suitable for multiple uses, including structural members, siding, roofing, interior finishes, and decorative features. Many of the first structures in the earliest settlements were built with logs, which were readily available, did not require much finishing, and could be quickly erected with basic tools.

Water-powered sawmills cut logs into timbers and boards, but detailed ornamental features were generally crafted on site using hand tools until after the Civil War. Mechanized production increased the efficiency of cutting logs into timbers, boards, and more intricate components, and the structural and decorative potential of wood's use in building construction expanded. With more efficient production came lower costs, but also the standardization of ready-made moldings and assemblies for windows, doors, and decorative features. Initially, wood was primarily sourced locally, but improved transportation systems made a greater variety of wood species more accessible all over the country. With broader availability, a particular wood could be selected for its suitability in a specific application; however, local species were used most often.

The extensive use of wood in buildings can be attributed to its many properties that include strength in both tension and compression; ease with which it can be cut and shaped; capability to be connected using a variety of fasteners and adhesives; ability to be painted or varnished; and resistance to wear and weather. All of these characteristics, and some more than others, vary according to the species of wood. Although many types and species of wood used historically are no longer available, wood selection and construction practices have always capitalized on its attributes and compensated for its weaknesses. Their resistance to decay made white oak and cedar common choices for roofing shingles, while oak and maple were frequently chosen for flooring because of their hardness. Pine and yellow poplar have often been used for siding and trim because of

their straight grain and ease of milling, but they must be painted to protect them from decay.

Plywood is an engineered product formed by laminating thin sheets of wood together; it was introduced to the U.S. building industry in the early 20th century. Because plywood has greater structural potential than wood, and as a sheet can be installed more efficiently, it soon replaced boards as sheathing before being replaced itself by less-expensive *particle board* for many applications. By applying surface veneers and adhesives, plywood can also be used as siding or for fine interior finishes on paneling or cabinetry. *Glued laminated timber* (glulam), first manufactured in the 1930s, is another engineered wood material. It is an important material in mid-20th-century buildings and often used for massive arches and trusses in sports arenas and similar large, open, column-free spaces.

Many historic buildings have wood structural systems and features, such as stairs or columns. The majority of both practical and decorative features, particularly on the interior, are made of wood, such as flooring and paneling.



Metals

Metal features—including steps, porches, railings, balconies, and entire facades; cornices, siding, cladding, roofs, roof cresting, and storefronts; and doors, window sash, entablatures, and hardware—are often highly decorative as well as practical and are important in defining the overall character of historic American buildings.

Metals commonly used in historic buildings include *lead, tinplate, terneplate, zinc, copper, bronze, brass, iron, steel, aluminum, stainless*

steel, and a variety of other *alloys*. Historic metal building components were often designed by highly-skilled artisans. By the late 19th century, many of these components were prefabricated and available from catalogues in standardized sizes and designs.

Wrought iron is the form in which iron was first used in America. In the beginning, most wrought-iron architectural elements were small, such as nails, tie rods, straps, and hardware. Wrought-iron features



gradually increased in size to include balconies, railings, porches, steps, and fencing. It was not used for structural components until around the mid 19th century, when manufacturing equipment became more sophisticated. *Cast iron* was initially imported from England. Although there were some iron-casting works established before the Revolution, by the early 19th century production had expanded to make a variety of cast-iron features. Structural cast-iron columns were first used in the 1820s, and cast-iron building fronts and decorative structural and ornamental features followed soon after. Cast and wrought iron are often used on the interior of historic buildings as both structural and decorative features, such as columns, staircases, railings, and light fixtures.

Steel, which is an alloy of iron and usually carbon, increased in popularity as manufacturing processes and production improved in the mid-19th century. Structural steel played an important role in the development of high-rise buildings and the skyscraper.

Lead was first used in historic buildings for roofing. *Tinplate or terneplate*, which was made by applying a lead and tin coating to sheet metal or steel, became a common roofing material after it was first produced in the 1820s. (Pure tin was rarely used as a building material because it is so soft.) The application of a *zinc coating* on sheet metal created *galvanized iron*, which was used for roofing and decorative roofing features, such as steeples and roof cresting, as well as other ornamental architectural features, such as door and window hood molds, lintels, and oriel and bay windows. Prefabricated Quonset huts constructed of *corrugated galvanized steel* began to be manufactured during World War II for the military on the battlefield for housing, storage, and other uses.

Entire pressed-metal and galvanized-iron storefronts and individual decorative features were manufactured to simulate wood, stone, or cast iron from the latter part of the 19th century into the early years of the 20th century. *Copper* roofs were installed on many public buildings from the 1790s through the first quarter of the 19th cen-

ture. Copper continues to be used, often for porch roofs as well as gutters, downspouts, and flashing. *Bronze* and *brass* are both alloys of copper. Bronze, which weathers well, appears as entrance doors and historic storefronts. Brass, usually polished, is used for decorative interior features, such as grilles and elevator doors. *Nickel*, when employed as a building component, is in the form of an alloy, usually *nickel silver*, *Monel*, or some *stainless steel*. In comparison to other construction metals, stainless steel is quite new, essentially only coming into use in the 1920s when it became a favorite material for Art Deco-style buildings.

Aluminum—lightweight and corrosion-resistant—was not utilized much in buildings because it was so expensive until the 1920s, when expanded production reduced its cost. Aluminum siding, which was advertised as maintenance free, became a popular siding material for single-family residences after it was introduced in the late 1930s. Some of the uses of aluminum include roofing and roofing features, such as gutters, downspouts, and flashing, as well as windows and storefront surrounds.

Porcelain enamel, or *vitreous enamel*, is composed of a thin coating of glass fused to cast-iron or steel sheets, panels, tiles, or shingles. Although developed in the late 19th century, it was not commonly used in buildings until the late 1920s and 1930s for Art Deco and Art Moderne storefronts. Lustron houses, constructed of prefabricated, enameled steel panels and intended for mass production, were introduced in the late 1940s in anticipation of the need for housing after the war. These houses were promoted for their low maintenance, in part because the walls, ceilings, and other interior surfaces were also enameled steel panels and easily washable.

Glass

For centuries, only blown *cylinder* and *crown* glass in small pieces was available and it was expensive. Thus, the glass in early windows in American buildings consisted of small panes which gradually increased in size over the years. With the invention of cast plate glass in 1848, large plates of glass could be manufactured which were strong and inexpensive. *Plate glass* was first used in the early 1850s as the primary exterior material (with a cast-iron framework) for such structures as international exhibition buildings, worlds' fair pavilions, and greenhouses and conservatories. In the early 20th



century, architects began using glass curtain walls in Art Moderne-style architecture and, most notably, the International Style. *Tempered glass* is a hardened or toughened glass which began to be used in building construction around 1940. By the middle of the 20th century, glass as a cladding system became synonymous with curtain wall systems.

In addition to clear glass—flat or sometimes curved—there is also stained glass, tinted, patterned, textured, etched, frosted, leaded, painted, colored opaque glass and spandrel glass, prism glass, decorative Val de Verre glass (colored art glass), ceramic frit (pigmented glass enamel fused to a glass surface), and glass block. Many of these types of glass can be found in windows, transoms, doors and entrances, and storefront display windows, whereas some of them—especially opaque, pigmented structural glass with trade names such as Vitrolite, Carrara Glass, and Sani Onyx—are more likely to appear as exterior cladding on Art Deco-style or Art Moderne storefronts. *Spandrel glass* was first introduced on mid-20th-century buildings, particularly in storefront and curtain wall systems. Glass was also used historically in skylights and monitors; in theater, hotel, and apartment building marquees and canopies; and as a component of lightning rods and weathervanes, address plates, and signage.

Glass features on the interior of historic buildings include transoms, windows, privacy screens, office dividers, wall partitions for borrowed light in office corridors, teller windows in banks, ticket windows in train stations and movie theaters, doorknobs, light fixtures, mirrored wall inlay, and also, beginning in the latter part of the 20th century, wall mosaics. Pigmented structural glass can be found in bathrooms and some kitchens because of its sanitary qualities.

Low-e (low emissivity) *glass*, which is primarily used in windows to minimize solar gain, was developed in the last quarter of the 20th century. *Impact-resistant glass* is another more-recently developed type of glass designed to withstand hurricane-force wind and which can also be installed as a blast-resistant security feature.

Paint and Other Coatings

Paints and paint-like coatings have been used on historic buildings in America as protective coatings and for decorative treatments.

What is commonly considered to be paint is a liquid consisting of a pigment which makes it opaque and colors it, a binder or base to hold it together, and sometimes a vehicle to carry the pigment. Many historic paints contained lead in the form of lead white, included as a “concealing” pigment that provided opacity, although zinc oxide was also used as an alternative. Lead increased durability and prevented mold and mildew. Titanium dioxide was sometimes used as a substitute for lead in the early 20th century, but lead continued to be an ingredient in most paints until it was banned as a hazardous substance in the U.S. in 1978. Traditional paints had an oil base, usually linseed, and the earliest paint colors were, for the most part, derived from natural pigments. Like today, both glossy and flat (or matte-finish) paints were used historically on the exterior and the interior of a building. After 1875, factory-made paints were readily available. Masonry and wood stains are traditional coatings which also consist of a pigment, a solvent, and little, if any, binder. They have a flat finish and are transparent rather than opaque so that the substrate is still visible.

Other historic paints, such as *whitewash*, are water based and have a flat finish. In addition to water, whitewash is composed of hydrated (slaked) lime, salt, and various other materials and sometimes includes a natural pigment. Whitewash was used on interior plaster, in cellars, and on wood structural components, but not on wood doors, windows, or trim because its flat finish easily rubs off. Whitewash was also used on the exterior of brick or stone buildings, wood fences, and farm outbuildings as a protective coating. Often it was reapplied on an annual basis when it got dirty or if it wore off due to exposure to the weather. *Calcimine* (or *kalsomine*) and *distemper* paints were also water based and included natural glues, gelatin, gums, and whiting to which colored pigments could be added. They were used only on the interior and usually on plaster surfaces. *Casein* is a milk-based paint composed of hydrated lime, pigment, often oil, and a variety of additives to increase its

durability. It was used on both the exterior and the interior of buildings.

The interiors of historic buildings can exhibit a multitude of decorative painted treatments. Marbleized and grained finishes were applied to wood, stone, and plaster to give them the appearance of more exotic and costly materials. Other interior painted treatments, such as murals and stencils, are purely decorative. *Tempera* and *gouache* are traditional water-based paints used almost exclusively for decorative painting.

Experimentation that began early in the 20th century resulted in the development of acrylic water-based paint, commonly known as *latex paint*. *Oil-based/alkyd paint* continues to be used in the 21st century and is still preferred for certain applications. Latex paint tends to be more popular not only because it is water-based (making clean up easy during and after painting), but it also has fewer toxic vapors and, like solvent-based oil/alkyd paints, is very durable.

Varnish, which is used primarily on interior wood features but also on exterior entrance doors, is another traditional coating. Unlike paint, varnish is transparent, composed of a resin, a drying oil, and a solvent. It has a glossy finish, which dulls over time.





Composite Materials: Plastic, Resin, and Vinyl; Fiber-Reinforced Cement Siding; Fiberboard; and Floor Coverings

Plastic is a malleable material composed of synthetic or natural organic materials made from various organic polymers, such as *polyethylene* and *polyvinyl chloride* (PVC), which can be poured into molds or rolled in sheets. It is generally agreed that the term *plastic* was introduced into popular usage in 1907 to describe the first fully synthetic plastic. Improved plastics were available in America by World War I. Production soared during World War II because plastics were needed to make up for the shortage of other materials. In mass production by the 1950s, the industry continued to expand with the development of increasingly more sophisticated plastics.

Vinyl siding came on the market in the late 1950s, and its use, primarily in residential construction, increased as the product improved over the years. Coating canvas awnings with vinyl helped to extend their lifespan, evolving, eventually, into awnings manufactured solely of vinyl. Plastic signs on the exterior of historic commercial buildings changed and radically expanded the role of signage as advertising as well as being important design features themselves. Plastic was used sometimes for decorative trim on storefronts. Vinyl-coated wallpaper was used as early as the 1920s and is still selected for restaurants, commercial spaces, and hospitals because it is durable and washable. Other plastic materials became popular in the 1950s in the form of plastic-laminate sheeting and wall tiles.

Fiber-reinforced plastic (FRP), is made of a polymer matrix mixed with fiber, usually *fiberglass*, to add strength; it is noted for its ability to be molded in thin shells. FRP is sometimes used as a substitute material to recreate missing or deteriorated architectural features in historic buildings. *Acrylic plastic* is a transparent synthetic plastic,

generally identified by one of its trade names—*Plexiglass* or *Lucite*—which was patented in the 1950s as an alternative to glass. *Foamed polystyrene*, better known as *Styrofoam*, was first used in the mid-1950s as building insulation.

Fiber-Reinforced Cement Siding is a composite material made of sand, cement, and cellulose fibers. It was developed in the latter part of the 20th century as a less-hazardous replacement for asbestos cement siding, which preceded it, and was used for siding and roofing shingles from the early 20th century to the 1970s. Fiber-reinforced cement siding is frequently installed in the form of horizontal boards or vertical panels as exterior siding. Fiber-reinforced cement is used on both residential and commercial buildings.

Fiberboard is a composite hardboard material made from pressure-molded wood fibers. It had early precedents in the late 18th century, but was first manufactured in large quantities in the 1920s, with its use expanding in the 1930s and 40s. Fiberboard (or wallboard, as it is commonly known) was marketed by various companies, such as *Masonite*. It was used as sheathing for roofing and siding on the exterior, for insulation, and for interior walls.

The first composite floor covering was *Linoleum*, made from oxidized linseed oil and ground cork or wood flour. Its manufacture in the U.S. began in the late 19th century, about the same time synthetic *rubber floor tile* was also introduced. *Asphalt floor tiles* were first used in the 1920s and remained popular into the 1950s. *Plastic/vinyl* replaced asphalt as a binder in floor tiles in the late 1920s, in part because plastic, unlike asphalt, could be made in lighter colors and a greater variety of colors. Semi-flexible vinyl flooring, manufactured in the form of tiles or rolled sheets, was developed by the 1930s. After the war, it became more affordable and frequently was chosen for both residential and commercial interiors.

Imitative Materials

Imitative building materials are generally common and readily available materials used to simulate a more expensive material. They have a long history in American building construction. *Wood*, cut and planed and sometimes coated with a sand paint, has been used since the 18th century to replicate cut blocks of stone and quoins on the exterior of a building. *Stucco*, applied over any kind of construction (from log to rubble masonry) and scored to resemble stone, could make even a log house look elegant. *Cast iron* and *pressed metal*, whether as a complete façade, a storefront, or an individual feature such as a window hood, cornice, or decorative pilaster, were also used on the exterior of buildings to replicate stone. Not only *architectural terra cotta*, but *cast stone* served as a substitute for stone. *Metal* and *concrete* roofing tiles were used as less-costly alternatives to clay roofing tiles.

In the 20th century, the use of exterior imitative materials expanded as new products were developed. *Asphalt roll siding* that resembled brick could be applied to a wood building, and *asbestos composite shingles* were produced to replace not only wood shingle siding, but also slate roofing shingles. *Aluminum siding* has been used as a replacement for wood siding, followed by *vinyl siding*, *pressed wood siding*, and, more recently, *composite* or *fiber-cement siding*. Manufactured *faux slate roofing* became popular because it costs less than slate and is lighter weight. Over the years, imitative materials have increased in variety as synthetic materials continue to be introduced, including a substitute, an *exterior insulation and finish system (EIFS)*, for another imitative material—stucco. Imitative materials are also used to recreate missing or deteriorated architectural features in historic buildings.

On the interior, imitative materials, such as *scored plaster*, were historically applied to walls to give the appearance of stone. *Painted* or *marbleized finishes* on plaster or wood could further simulate stone, and *decorative graining* could transform the surface of a common wood into a more exotic species. *Scagliola*, which is often applied to brick columns, is a very old technique that uses a plaster-like com-

posite material to simulate marble. *Lincrusta*, an embossed wall covering, was developed in the late 19th century to simulate pressed metal. *Embossed wall coverings* continue to be produced in the 21st century. Concrete, vinyl, and other manufactured flooring materials are designed in many patterns and colors to replicate brick, stone, clay tile, and wood.



Roofs

The roof—with its form; features such as cresting, dormers, cupolas, and chimneys; and the size, color, and patterning of the roofing material—is an important design element of many historic buildings. In addition, a weathertight roof is essential to the long-term preservation of the entire structure. Historic roofing reflects availability of materials, levels of construction technology, climate, and cost.

Throughout all periods of American history, with only minor exception, *wood* has been used for roofing; despite the early use of many other materials, wood shingles remained the most common roofing material throughout much of the 19th century. Initially the species of wood used would have been specific to a region, but the quality and design of a building were usually the prime determinants in the way wood was used, ranging from wide, lapped boards to small, uniform, geometrically-shaped shingles.



Clay tile was used at least in a limited way in the first settlements on the East coast and it was manufactured in America by the mid 17th century. The Spanish influence in the use of clay roofing tiles is apparent in buildings in the south, southwest, and western parts of the country. *Slate* was also an early roofing material, but it was imported until the end of the 18th century when the first slate quarry opened. Both slate and tile roofs

provided fire protection, especially important in urban areas. The use of slate expanded quickly in the second half of the 19th century with the development of the railroads, and it remained a preferred roofing material until the middle of the 20th century.

Lead and *copper* were the first metals used for roofing, later joined by *zinc* and *iron* in the beginning of the 19th century. Lead was used in the mid 19th century for flashing and sometimes for the roofs of bay windows, domed, or steeply-pitched sections of a larger roof, and steeples. Copper has continued in use for roofing, gutters, downspouts, and flashing.

Painted iron was initially used in large sheets, but it was replaced with smaller sheets of iron plated with *tin* or *terne*—a lead-tin mix—which were a more successful roofing material. As plated iron and, later, *steel* became widely available, their light weight, fire resistance, and low cost made them the ideal alternative to wood shingles. *Galvanized metal*—base steel coated with an alloy of zinc—gained widespread popularity in the 20th century. Galvanizing not only protects metal from rusting, but it also adds strength; corrugated sheet metal, when galvanized, became the preferred metal roofing material because it reduced the need for sheathing. Galvanized steel also could be stamped into sheets simulating shingles and clay tiles.

In the late 19th century, *concrete* roofing tiles began to be produced as a substitute for clay tiles. At about the same time, *composition* roofing (built-up or roll roofing) was developed. This is a layered assembly of felt sheets and coal tar or asphalt, topped with gravel that is suitable for waterproofing flat and low-sloped roofs. Shortly after the start of the 20th century, *asbestos fiber cement* and *asphalt* shingles came into use as less-expensive alternatives to slate. Later in the 20th century, sheets of *modified bitumen* and *synthetic rubber* provided more options for a flat roof. By the end of the 20th century, *liquid* and *vinyl membranes* were also installed on flat roofs, and *synthetic recycled materials* were used increasingly for both new and replacement roofs.

Windows

Technology and prevailing architectural styles shaped the history of windows in America. The earliest windows were essentially medieval in their form. Small panes of glass, usually diamond-shaped and held together with lead, were set in a hinged casement sash of wood or iron. By the beginning of the 18th century, the glass had increased in size and had become rectangular, with putty holding it in place. Wood muntins replaced lead came between the panes, and two sashes were placed in a frame where the lower one could slide vertically. Such simple windows remained common in utilitarian buildings well into the 20th century. With the introduction of iron pulleys, the sash could be hung from cords connected to counterweights, which resulted in single-hung windows, or double hung when both sashes were counterbalanced.

Sash increased in depth as it evolved, providing additional strength that allowed narrower muntins. As the production of glass (blown initially as a disk and later as a cylinder) improved, larger pieces of glass became more affordable, resulting in fewer panes of glass in a window. A sash that would have had twelve panes of glass in the 18th century often had only two by the mid 19th century. After about 1850, with the advent of mass-produced millwork, standard profiles and sizes of windows were established with a wide variety of designs and glazing configurations that could be purchased from catalogues. The Chicago window, which featured a large fixed pane of glass in the center with a narrow, double-hung, operable sash window on either side of it, was introduced in the last decades of the 19th century as a feature of the Chicago School-style of architecture. The picture window, popular in ranch-style houses in the mid 20th century, evolved from this.

Steel was employed beginning at the end of the 19th century to build fire-resistant windows in tight urban environments. These hollow-core windows were frequently galvanized. Windows with solid, rolled steel sections were first produced in the first decade of the 20th century in many forms, ranging from casements (especially popular in domestic construction) to large, multi-pane units

that provided whole walls of natural light in industrial and warehouse buildings. Operable vents in these large windows pivoted on simple pins. Their relatively small panes and the fact that they were puttied in from the interior made the inevitable breakage easy and inexpensive to repair. Rolled steel was also used for double-hung windows, which were common in high-rise buildings in the 1920s and beyond. Aluminum windows were developed in the 1930s and, by the 1970s, rivaled wood in popularity, particularly in commercial and institutional buildings. They were produced in a variety of styles and functionality, including casement, hopper, awning, and double-hung sash.

Metal-clad (initially copper) wood windows appeared early in the 20th century but were not common until the later part of the century, when enameled aluminum cladding replaced copper. Although used primarily as replacements in older buildings, vinyl windows were developed in the latter part of the 20th century and marketed as inexpensive and thermally efficient. Modern windows are also made of fiberglass and polymer-based composites.

Storm windows were used historically and are still used to help regulate interior temperatures. Limited commercial use of thermal-pane or insulated glass in windows began in the 1930s, but it was not readily available until about 1950. Tempered glass also came into use about this time. Since then, work has continued to improve its efficiency and to reduce the effect of ultra-violet rays with tinted and low-e (low emissivity) glass. Impact-resistant glass is not new, but its use in windows continues to expand to meet modern hurricane code requirements as well as protection and security requirements.

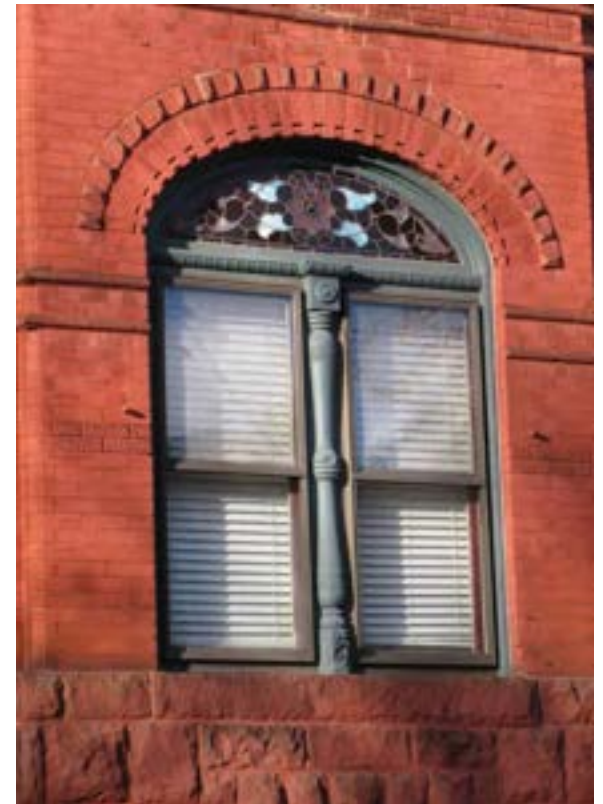

Entrances and Porches

Entrances and porches are often the focus of historic American buildings. With their functional and decorative features (such as doors, steps, balustrades, columns, pilasters, and entablatures), they can be extremely important in defining the historic character of a building. In many cases, porches were also energy-saving features and remain so today, shading southern and western elevations. Usu-



ally, entrances and porches were integral components of a historic building's design; for example, porches on Greek Revival houses, with pediments and Doric or Ionic columns, echoed the architectural elements and features of the building itself. Center, single-bay porches or arcaded porches are evident in Italianate-style buildings of the 1860s. Doors of Renaissance Revival-style buildings frequently featured entablatures or pediments. Porches characterized by lathe-turned porch posts, railings, and balusters were especially prominent and decorative features of Eastlake, Queen Anne, and Stick-style houses. Deep porches on bungalows and Craftsman-style houses of the early 20th century feature tapered posts, exposed posts and beams, rafter tails, and low-pitched roofs with wide overhangs.

Late 19th- and early 20th-century high-rise buildings are often distinguished by highly-ornamented entrances, some with revolving doors, which were introduced around the turn of the 20th century. Some commercial structures in the early- to mid-20th century have recessed entrances with colorful terrazzo flooring. Entrances to Art Deco-style residential and commercial buildings often feature stylized glass and stainless-steel doors with geometric designs. Entrances on modernist buildings may have simple glazing and, frequently, projecting concrete or metal canopies.

Porches can have regional variations, not only in style, but also in nomenclature. For instance, in Hawaii, *lanai* is used to describe a type of porch which might be known as a *veranda* in some parts of the South, a *piazza* in Charleston, or a *gallery* in New Orleans.

Storefronts

The storefront is often the most prominent feature of a historic commercial building, playing a crucial role in a store's advertising and merchandising strategy. The earliest storefronts in America, dating from the late 18th and early 19th centuries, had small, residential-style windows with limited display space. A few featured oriel windows or glass vitrine cases (sometimes added later) that projected out from the façade. Early storefront systems were frequently wood. In the 19th century, storefront display windows progressively increased in size as plate glass became available in larger units. This reflected the fact that cast-iron columns and lintels were thinner, allowing larger sheets of glazing that became available at about the same time. In some regions, storefronts and the entire building façade were constructed entirely of cast iron, later followed by galvanized metal, copper, bronze, and aluminum.

Historic storefront systems have many different configurations: they may have multiple entrance doors (including one to access an upstairs apartment if one exists); they may be symmetrical or asymmetrical; and entrances may be flush or recessed from the shop's windows. Transoms, sometimes with prism glass, are often a component of storefronts. In the 19th century, awnings added another feature to the storefront. Permanent metal canopies attached to the façade or supported by free-standing posts or columns, as well as retractable canvas awnings, provided shelter for customers and merchandise alike. As the 20th century progressed, new storefront designs were introduced, some with deeply recessed entrances with expanded display cases or "floating display islands." In the 1920s, 1930s, and later, structural pigmented glass such as Carrara Glass, Vitrolite, and Sani Onyx; aluminum and stainless steel; porcelain enamel; glass block; neon signs; and other new materials were introduced in Art Deco-style and Art Moderne storefronts. Modular storefront systems were introduced after World War II.

Storefronts are typically altered more than any other building feature to reflect the latest architectural styles and appear up-to-date



to attract customers. Older storefronts were often remodeled with a new design and materials by installing pigmented structural glass, for instance, and other 20th-century materials. These altered storefronts may have acquired significance in their own right and, in this case, should be retained.

Curtain Walls

Curtain wall construction was originally based on a steel framework. Today, most curtain wall construction utilizes an extruded aluminum framework, which became popular in the 1930s in the U.S. and came into its own after World War II. A curtain wall is not a structural system and, although it is self supporting, does not carry the weight of the building. Rather, it is an exterior wall hung or attached to the structural system. Curtain wall construction most frequently employs glass, metal panels, thin stone veneer, and other cladding materials, although louvers and vents, like glass panels, can also be set into the metal framework. Newer curtain wall systems may



incorporate rain screens and glass fiber reinforced concrete panels (GFRC). Because curtain wall construction uses relatively lightweight and less expensive materials, it reduces building costs, which, in part, explains its popularity.

There are essentially two types of curtain wall systems: *stick* systems and *unitized* or *modular* systems. A *stick* system is a framing system composed of long metal pieces (sticks) put together individually using vertical pieces (mullions) between floors and horizontal pieces between the vertical members. The framing members may sometimes be assembled in a factory, but the installation and glazing is done on site. A *unitized* or *modular* curtain wall system consists of ready-to-hang, pre-assembled modules which already include glazing or other panel infill. These modular units are usually one story in height and approximately five- to six-feet wide. Both types of curtain walls are attached to floor slabs or columns with field-drilled bolts in mated, adjustable anchor brackets.

Glass panels in curtain wall systems can be fixed or operable and can include spandrel glass, clear, or tinted glass. Stone veneer panels may be slate, granite, marble, travertine, or limestone. Metal panels can be aluminum plate, stainless steel, copper, or other non-corrosive types of metal. Other materials used in curtain wall systems include composite panels (such as honeycomb composite panels, consisting of two thin sheets of aluminum bonded to a thin plastic layer or rigid insulation in the middle); architectural terra cotta; glazed ceramic tile; and fiber-reinforced plastic (FRP).

Structural Systems

Numerous types of structural systems have been employed in the construction of buildings throughout American history. Some systems and building methods overlapped, and many remained in use for years. These systems—listed according to the period when they were first introduced—include but are not limited to: *wood-frame* construction (17th century), *load-bearing masonry* construction (18th century), *balloon-frame* construction (19th century), *brick cavity-wall* construction (19th century), *heavy-timber post and beam* industrial construction (19th century), *fireproof iron* construction (19th century), *heavy masonry and steel* construction (19th century), *skeletal steel construction* (19th century), *light frame and veneer brick* construction (20th century), and *cast-in-place concrete, concrete block, and slab and post* construction (20th century).

Exposed iron and steel structural systems are character defining in many utilitarian and industrial structures of the late 19th and early 20th centuries that have large open interior spaces, such as train sheds and armories. Exposed wood structural systems became an important interior decorative element during the Arts and Crafts period and in Craftsman-style bungalows in the early 20th century. Exposed cast-concrete structural systems and system components define the character of many industrial interiors and, later, other interior spaces in 20th-century buildings.

If features of the historic structural system are exposed (such as load-bearing brick walls, cast-iron columns, roof trusses, posts and



beams, vigas, and outriggers, or masonry foundation walls), they are likely to be important in defining the building's overall historic character. A concealed structural system, although not character defining, may still be significant as an example of historic building technology.

Mechanical Systems

Mechanical, lighting, and plumbing systems improved significantly with the onset of the Industrial Revolution. The 19th-century interest in hygiene, personal comfort, and reducing the spread of disease resulted in the development of central heating, piped water, piped gas, and networks of underground cast-iron sewers in urban areas. The mass production of cast-iron radiators made central heating affordable to many. By the turn of the 20th century, it was common for heating, lighting, and plumbing to be an integral part of most buildings.

The increasing availability of electricity as the 20th century progressed had a tremendous effect on the development of mechanical systems and opened up a new age of technology. Electric lighting brightened the interiors of all types of buildings, as well as building exteriors, their sites, and settings. Electricity not only improved heating systems, but in the 1920s it also brought central air conditioning to movie theaters and auditoriums, where it was first installed. By the middle of the 20th century, forced-air systems



provided both heat and cooling in many buildings. In the late 20th century, as HVAC systems increased in efficiency, they decreased in size, with smaller components, such as split ductless systems with wall-mounted air handlers, cassette ceiling-mounted diffusers, or high-velocity mini duct systems. These systems can be especially useful for retrofitting historic buildings because they are small and unobtrusive. Heat pumps, another late-20th century invention, can help to supplement existing HVAC systems.

Replacing hydraulic elevators, which were invented in the mid-19th century, with electric elevators in the early decades of the 20th century resulted in a boom in the construction of taller high-rise buildings and skyscrapers. Escalators, also invented in the mid 19th century, became more and more common as the 20th century advanced. By the latter part of the century, moving walkways helped facilitate travelers' passage from one place to another in transportation centers, such as airports.

The visible decorative features that remain of historic mechanical systems (such as grilles, lighting fixtures, elevator doors, and escalators) themselves may contribute to the overall historic character of the building and should be retained when feasible. Reusing an existing, functioning system and upgrading it as needed, should always be considered when feasible. However, because a mechanical system needs to work efficiently, most historic or older systems will likely need to be replaced to meet modern requirements.

INTERIOR SPACES, FEATURES, AND FINISHES

Spaces

The earliest buildings in America were very basic and likely to have only one or, perhaps, two rooms. As communities became more established and prosperous, buildings—houses in particular—increased in size, and construction became more elaborate and sophisticated, reflecting the wealth and tastes of individual owners. Larger buildings inevitably included multiple rooms designed to accommodate a variety of purposes. Thus, the interior floor plan, the arrangement and sequence of spaces, and built-in features and applied finishes are individually and collectively important in defining the historic character of the building. With the exception of most historic utilitarian buildings, manufacturing and industrial buildings, garages, and maintenance facilities, interiors are typically composed of a series of primary and secondary spaces. This succession of spaces is applicable to many historic buildings, from courthouses to cathedrals to cottages and commercial structures. Primary spaces, including entrance halls, lobbies, double parlors, living rooms, corridors, and assembly spaces, are defined not only by their function, but also by their location, features, finishes, size, and proportion.

Secondary spaces in historic interiors are generally more functional than decorative and, depending on the building's use, may include kitchens, bathrooms, utility rooms, attics, basements, mail rooms, rear hallways, and most office spaces. Although these spaces were important to how the building functioned historically, they are generally less significant than primary spaces and, thus, are usually the most appropriate places to make changes which may be necessary in a historic building, such as those required to meet code or to install mechanical equipment. The traditional sequence of interior spaces in late 19th- through early 20th-century high-rise buildings went from public areas (such as the lobby) on the first floor

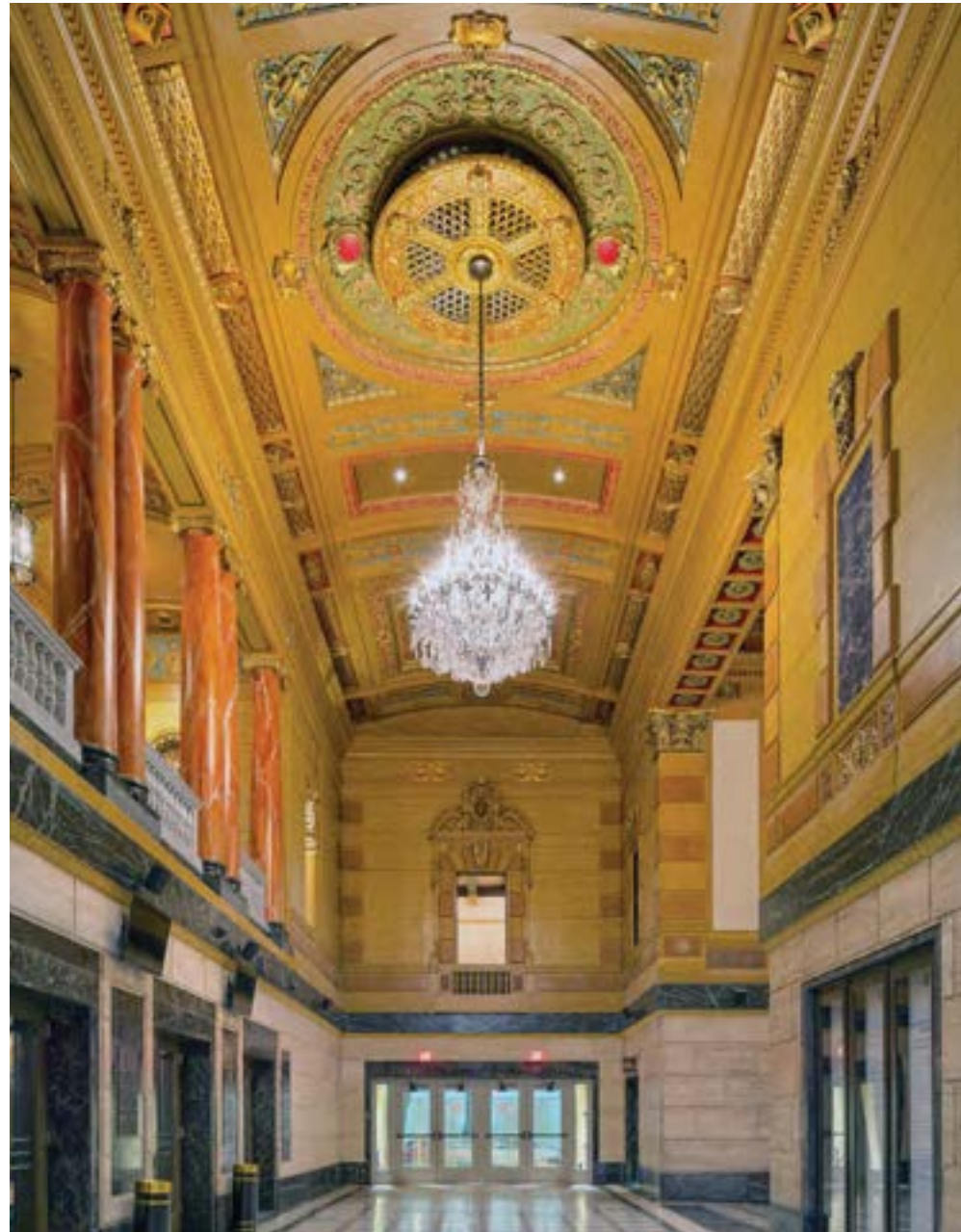

and corridors on upper floors to the private spaces behind them (i.e., offices, apartments, or hotel rooms). This hierarchy of spaces continues to define the historic character of many high-rise buildings. However, in commercial structures built on speculation with open floor plans, the upper floors, especially, are likely to have been reconfigured many times. In some cases, these interiors may have little historic character but, in others, the spaces and their appearance may have acquired significance because of a specific tenant, use (such as a boardroom or executive office), or an event.

Features and Finishes

Historic character-defining features and finishes can range from very elaborate to very simple and plain, or from formal to utilitarian. The interior features that are important to a particular building generally reflect its original or historic use. Thus, the interior features and finishes of industrial and factory buildings are basic and practical, with exposed structural systems; wood, brick, or concrete walls and floors; large windows or monitors with clerestory windows to provide natural light; and minimal or no door and window surrounds. Commercial, office, hotel, and high-rise apartment buildings have public spaces that often include highly-decorated lobbies, elevator lobbies with marble flooring, wood or marble wainscoting in the upper corridors and, particularly in office buildings, offices separated from hallways by heavy doors with glass transoms and glass wall partitions for borrowed light. The repetitive pattern itself of the corridors on the upper floors in these multi-story buildings is also often significant in defining their historic character. Individual historic residential structures frequently have painted plaster walls and ceilings, door and window trim, fireplaces with mantels, wood flooring, and a staircase if the house has more than one story. Some mid-to late-20th-century houses that are less traditional in design have simpler and less-ornamented interiors.

Building Site

The building site consists of a historic building or buildings, structures, and associated landscape features and their relationship within a designed or legally-defined parcel of land. A site may be significant in its own right or because of its association with the historic building or buildings.



Setting (District/Neighborhood)

The setting is the larger area or environment in which a historic building is located. It may be an urban, suburban, or rural neighborhood or a natural landscape in which buildings have been constructed. The relationship of buildings to each other, setbacks, fence patterns, views, driveways and walkways, and street trees and other landscaping together establish the character of a district or neighborhood.



Special Requirements: Code-Required Work

Sensitive solutions to meeting code requirements are an important part of protecting the historic character of the building. Thus, work that must be done to meet accessibility and life-safety requirements must always be assessed for its potential impact on the historic building.

Accessibility

It is often necessary to make modifications to a historic building to make it compliant with accessibility code requirements. Federal rules, regulations, and standards provide guidance on how to make historic buildings accessible. Work must be carefully planned and undertaken in a manner that results in minimal or no loss of historic exterior and interior character-defining spaces, features, or finishes. The goal should be to provide the highest level of access with the least impact to the historic building.



Life Safety

When undertaking work on historic buildings, it is also necessary to consider the impact that meeting life-safety codes (public health, occupational health, life safety, electrical, seismic, structural, and building codes) will have on both exterior and interior spaces, features, and finishes. Historic building materials that are hazardous, such as lead paint and asbestos, will require abatement or encapsulation. Some newer life-safety codes are more flexible and allow greater leniency for historic buildings when making them code compliant. It is also possible that there may be an alternative approach to meeting codes that will be less damaging to the historic building. Coordinating with code officials early in project planning will help ensure that code requirements can be met in a historic building without negatively impacting its character.



Resilience to Natural Hazards

The potential future impacts of natural hazards on a historic building should be carefully evaluated and considered. If foreseeable loss, damage, or destruction to the building or its features can be reasonably anticipated, treatments should be undertaken to avoid or minimize the impacts and to ensure the continued preservation of the building and its historic character. In some other instances, the effects may be minimal or more gradual and the impacts unknown or not anticipated to affect the property until sometime in the future. In all instances, a building should be maintained in good condition and monitored regularly, and historic documentation should be prepared as a record of the building and to help guide future treatments.

Some impacts of natural hazards may be particularly sudden and destructive to a historic building (such as riverine flash flooding,

coastal storm surge, an earthquake, or a tornado) and may require adaptive treatments that are more invasive. When a treatment is proposed for a building that addresses such potential impacts and will affect the building's historic character, other feasible alternatives that would require less change should always be considered first. In some instances, a certain degree of impact on a building's historic character may be necessary to ensure its retention and continued preservation. In other instances, a proposed treatment may have too great an impact to preserve the historic character of the building. A historic building may have existing characteristics or features that help to address or minimize the impacts of natural hazards. Some historic buildings may have been altered previously or be in regions where it has been traditional to adapt buildings frequently subject to damage from natural hazards, such as flooding. All these factors should be taken into consideration when planning preventive treatments. The goal should always be to minimize the impacts to the building's historic character to the greatest extent possible in adapting the building to be more resilient.



Sustainability

Before implementing any energy improvements to enhance the sustainability of a historic building, the existing energy-efficient characteristics of the building should be evaluated. Historic building construction methods and materials often maximized natural sources of heating, lighting, and ventilation to respond to local climatic conditions. The key to a successful project is to identify and understand any lost original and existing energy-efficient aspects of the historic building, as well as to identify and understand its character-defining features to ensure they are taken into account. The most sustainable building may be one that already exists. Thus, good

preservation practice is very often synonymous with sustainability. There are numerous treatments—traditional as well as new technological innovations—that may be used to upgrade a historic building to help it operate more efficiently while retaining its character.

The topic of sustainability is addressed in detail in *The Secretary of the Interior's Standards for Rehabilitation & Illustrated Guidelines on Sustainability for Rehabilitating Historic Buildings*. Although specifically developed for the treatment Rehabilitation, the Sustainability Guidelines can be used to help guide the other treatments.



New Exterior Additions and Related New Construction

A new exterior addition to a historic building should be considered in a rehabilitation project only after determining that requirements for a new or continuing use cannot be successfully met by altering non-significant interior spaces. If the existing building cannot accommodate such requirements in this way, then an exterior addition or, in some instances, separate new construction on a site may be acceptable alternatives.

A new addition must preserve the building's historic character, form, significant materials, and features. It must be compatible with the massing, size, scale, and design of the historic building while differentiated from the historic building. It should also be designed and

constructed so that the essential form and integrity of the historic building would remain if the addition were to be removed in the future. There is no formula or prescription for designing a compatible new addition or related new construction on a site, nor is there generally only one possible design approach that will meet the Standards.

New additions and related new construction that meet the Standards can be any architectural style—traditional, contemporary, or a simplified version of the historic building. However, there must be a balance between differentiation and compatibility to maintain the historic character and the identity of the building being enlarged.

New additions and related new construction that are either identical to the historic building or in extreme contrast to it are not compatible. Placing an addition on the rear or on another secondary elevation helps to ensure that it will be subordinate to the historic building. New construction should be appropriately scaled and located far enough away from the historic building to maintain its character and that of the site and setting. In urban or other built-up areas, new construction that appears as infill within the existing pattern of development can also preserve the historic character of the building, its site, and setting.



STANDARDS FOR REHABILITATION & GUIDELINES
FOR REHABILITATING HISTORIC BUILDINGS

Rehabilitation

Rehabilitation is defined as the act or process of making possible a compatible use for a property through repair, alterations, and additions while preserving those portions or features which convey its historical, cultural, or architectural values.



Standards for Rehabilitation

1. A property will be used as it was historically or be given a new use that requires minimal change to its distinctive materials, features, spaces and spatial relationships.
2. The historic character of a property will be retained and preserved. The removal of distinctive materials or alteration of features, spaces and spatial relationships that characterize a property will be avoided.
3. Each property will be recognized as a physical record of its time, place and use. Changes that create a false sense of historical development, such as adding conjectural features or elements from other historic properties, will not be undertaken.
4. Changes to a property that have acquired historic significance in their own right will be retained and preserved.
5. Distinctive materials, features, finishes, and construction techniques or examples of craftsmanship that characterize a property will be preserved.
6. Deteriorated historic features will be repaired rather than replaced. Where the severity of deterioration requires replacement of a distinctive feature, the new feature will match the old in design, color, texture and, where possible, materials. Replacement of missing features will be substantiated by documentary and physical evidence.
7. Chemical or physical treatments, if appropriate, will be undertaken using the gentlest means possible. Treatments that cause damage to historic materials will not be used.
8. Archeological resources will be protected and preserved in place. If such resources must be disturbed, mitigation measures will be undertaken.
9. New additions, exterior alterations, or related new construction will not destroy historic materials, features, and spatial relationships that characterize the property. The new work will be differentiated from the old and will be compatible with the historic materials, features, size, scale and proportion, and massing to protect the integrity of the property and its environment.
10. New additions and adjacent or related new construction will be undertaken in such a manner that, if removed in the future, the essential form and integrity of the historic property and its environment would be unimpaired.

GUIDELINES FOR REHABILITATING HISTORIC BUILDINGS

INTRODUCTION

In **Rehabilitation**, historic building materials and character-defining features are protected and maintained as they are in the treatment Preservation. However, greater latitude is given in the **Standards for Rehabilitation and Guidelines for Rehabilitating Historic Buildings** to replace extensively deteriorated, damaged, or missing features using either the same material or compatible substitute materials. Of the four treatments, only **Rehabilitation** allows alterations and the construction of a new addition, if necessary for a continuing or new use for the historic building.

Identify, Retain, and Preserve Historic Materials and Features

The guidance for the treatment **Rehabilitation** begins with recommendations to identify the form and detailing of those architectural materials and features that are important in defining the building's historic character and which must be retained to preserve that character. Therefore, guidance on *identifying, retaining, and preserving* character-defining features is always given first.

Protect and Maintain Historic Materials and Features

After identifying those materials and features that are important and must be retained in the process of **Rehabilitation** work, then *protecting and maintaining* them are addressed. Protection generally involves the least degree of intervention and is preparatory to other work. Protection includes the maintenance of historic materials and features as well as ensuring that the property is protected before and

during rehabilitation work. A historic building undergoing rehabilitation will often require more extensive work. Thus, an overall evaluation of its physical condition should always begin at this level.

Repair Historic Materials and Features

Next, when the physical condition of character-defining materials and features warrants additional work, *repairing* is recommended. **Rehabilitation** guidance for the repair of historic materials, such as masonry, again begins with the least degree of intervention possible. In rehabilitation, repairing also includes the limited replacement in kind or with a compatible substitute material of extensively deteriorated or missing components of features when there are surviving prototype features that can be substantiated by documentary and physical evidence. Although using the same kind of material is always the preferred option, a substitute material may be an acceptable alternative if the form, design, and scale, as well as the substitute material itself, can effectively replicate the appearance of the remaining features.

Replace Deteriorated Historic Materials and Features

Following repair in the hierarchy, **Rehabilitation** guidance is provided for *replacing* an entire character-defining feature with new material because the level of deterioration or damage of materials precludes repair. If the missing feature is character defining or if it is critical to the survival of the building (e.g., a roof), it should be replaced to match the historic feature based on physical or his-

toric documentation of its form and detailing. As with repair, the preferred option is always replacement of the entire feature in kind (i.e., with the same material, such as wood for wood). However, when this is not feasible, a compatible substitute material that can reproduce the overall appearance of the historic material may be considered.

It should be noted that, while the National Park Service guidelines recommend the replacement of an entire character-defining feature that is extensively deteriorated, the guidelines never recommend removal and replacement with new material of a feature that could reasonably be repaired and, thus, preserved.

Design for the Replacement of Missing Historic Features

When an entire interior or exterior feature is missing, such as a porch, it no longer plays a role in physically defining the historic character of the building unless it can be accurately recovered in form and detailing through the process of carefully documenting the historic appearance. If the feature is not critical to the survival of the building, allowing the building to remain without the feature is one option. But if the missing feature is important to the historic character of the building, its replacement is always recommended in the **Rehabilitation** guidelines as the first, or preferred, course of action. If adequate documentary and physical evidence exists, the feature may be accurately reproduced. A second option in a rehabilitation treatment for replacing a missing feature, particularly when the available information about the feature is inadequate to permit an accurate reconstruction, is to *design* a new feature that is compatible with the overall historic character of the building. The new design should always take into account the size, scale, and material of the building itself and should be clearly differentiated from the authentic historic features. For properties that have changed over time, and where those changes have acquired

significance, reestablishing missing historic features generally should not be undertaken if the missing features did not coexist with the features currently on the building. Juxtaposing historic features that did not exist concurrently will result in a false sense of the building's history.

Alterations

Some exterior and interior alterations to a historic building are generally needed as part of a **Rehabilitation** project to ensure its continued use, but it is most important that such alterations do not radically change, obscure, or destroy character-defining spaces, materials, features, or finishes. Alterations may include changes to the site or setting, such as the selective removal of buildings or other features of the building site or setting that are intrusive, not character defining, or outside the building's period of significance.

Code-Required Work: Accessibility and Life Safety

Sensitive solutions to meeting code requirements in a **Rehabilitation** project are an important part of protecting the historic character of the building. Work that must be done to meet accessibility and life-safety requirements must also be assessed for its potential impact on the historic building, its site, and setting.

Resilience to Natural Hazards

Resilience to natural hazards should be addressed as part of a **Rehabilitation** project. A historic building may have existing characteristics or features that help to address or minimize the impacts of natural hazards. These should always be used to best advantage when considering new adaptive treatments so as to have the least impact on the historic character of the building, its site, and setting.

Sustainability

Sustainability should be addressed as part of a **Rehabilitation** project. Good preservation practice is often synonymous with sustainability. Existing energy-efficient features should be retained and repaired. Only sustainability treatments should be considered that will have the least impact on the historic character of the building.

The topic of sustainability is addressed in detail in *The Secretary of the Interior's Standards for Rehabilitation & Illustrated Guidelines on Sustainability for Rehabilitating Historic Buildings*.

New Exterior Additions and Related New Construction

Rehabilitation is the only treatment that allows expanding a historic building by enlarging it with an addition. However, the **Rehabilitation** guidelines emphasize that new additions should be considered only after it is determined that meeting specific new needs cannot be achieved by altering non-character-defining interior spaces. If the use cannot be accommodated in this way, then an attached exterior addition may be considered. New additions should be designed and constructed so that the character-defining features of the historic building, its site, and setting are not negatively impacted. Generally, a new addition should be subordinate to the historic building. A new addition should be compatible, but differentiated enough so that it is not confused as historic or original to the building. The same guidance applies to new construction so that it does not negatively impact the historic character of the building or its site.

Rehabilitation as a Treatment. *When repair and replacement of deteriorated features are necessary; when alterations or additions to the property are planned for a new or continued use; and when its depiction at a particular time is not appropriate, Rehabilitation may be considered as a treatment. Prior to undertaking work, a documentation plan for Rehabilitation should be developed.*

MASONRY: STONE, BRICK, TERRA COTTA, CONCRETE, ADOBE, STUCCO, AND MORTAR

RECOMMENDED

NOT RECOMMENDED

<p>Identifying, retaining and preserving masonry features that are important in defining the overall historic character of the building (such as walls, brackets, railings, cornices, window and door surrounds, steps, and columns) and decorative ornament and other details, such as tooling and bonding patterns, coatings, and color.</p>	<p>Removing or substantially changing masonry features which are important in defining the overall historic character of the building so that, as a result, the character is diminished.</p> <p>Replacing or rebuilding a major portion of exterior masonry walls that could be repaired, thereby destroying the historic integrity of the building.</p> <p>Applying paint or other coatings (such as stucco) to masonry that has been historically unpainted or uncoated to create a new appearance.</p> <p>Removing paint from historically-painted masonry.</p>
<p>Protecting and maintaining masonry by ensuring that historic drainage features and systems that divert rainwater from masonry surfaces (such as roof overhangs, gutters, and downspouts) are intact and functioning properly.</p>	<p>Failing to identify and treat the causes of masonry deterioration, such as leaking roofs and gutters or rising damp.</p>
<p>Cleaning masonry only when necessary to halt deterioration or remove heavy soiling.</p>	<p>Cleaning masonry surfaces when they are not heavily soiled to create a “like-new” appearance, thereby needlessly introducing chemicals or moisture into historic materials.</p>
<p>Carrying out masonry cleaning tests when it has been determined that cleaning is appropriate. Test areas should be examined to ensure that no damage has resulted and, ideally, monitored over a sufficient period of time to allow long-range effects to be predicted.</p>	<p>Cleaning masonry surfaces without testing or without sufficient time for the testing results to be evaluated.</p>



[1] An alkaline-based product is appropriate to use to clean historic marble because it will not damage the marble, which is acid sensitive.



[2] Mid-century modern building technology made possible the form of this parabola-shaped structure and its thin concrete shell construction. Built in 1961 as the lobby of the La Concha Motel in Las Vegas, it was designed by Paul Revere Williams, one of the first prominent African-American architects. It was moved to a new location and rehabilitated to serve as the Neon Museum, and is often cited as an example of Googie architecture. *Credit: Photographed with permission at The Neon Museum, Las Vegas, Nevada.*

MASONRY: STONE, BRICK, TERRA COTTA, CONCRETE, ADOBE, STUCCO, AND MORTAR

RECOMMENDED

Cleaning soiled masonry surfaces with the gentlest method possible, such as using low-pressure water and detergent and natural bristle or other soft-bristle brushes.

NOT RECOMMENDED

Cleaning or removing paint from masonry surfaces using most abrasive methods (including sandblasting, other media blasting, or high-pressure water) which can damage the surface of the masonry and mortar joints.

Using a cleaning or paint-removal method that involves water or liquid chemical solutions when there is any possibility of freezing temperatures.

Cleaning with chemical products that will damage some types of masonry (such as using acid on limestone or marble), or failing to neutralize or rinse off chemical cleaners from masonry surfaces.



[3] Not Recommended:
The white film on the upper corner of this historic brick row house is the result of using a scrub or slurry coating, rather than traditional repointing by hand, which is the recommended method.



[4] Not Recommended:
The quoins on the left side of the photo show that high-pressure abrasive blasting used to remove paint can damage even early 20th-century, hard-baked, textured brick and erode the mortar, whereas the same brick on the right, which was not abrasively cleaned, is undamaged.

MASONRY: STONE, BRICK, TERRA COTTA, CONCRETE, ADOBE, STUCCO, AND MORTAR

RECOMMENDED	NOT RECOMMENDED
Using biodegradable or environmentally-safe cleaning or paint-removal products.	
Using paint-removal methods that employ a poultice to which paint adheres, when possible, to neatly and safely remove old lead paint.	
Using coatings that encapsulate lead paint, when possible, where the paint is not required to be removed to meet environmental regulations.	
Allowing only trained conservators to use abrasive or laser-cleaning methods, when necessary, to clean hard-to-reach, highly-carved, or detailed decorative stone features.	
Removing damaged or deteriorated paint only to the next sound layer using the gentlest method possible (e.g., hand scraping) prior to repainting.	Removing paint that is firmly adhered to masonry surfaces, unless the building was unpainted historically and the paint can be removed without damaging the surface.
Applying compatible paint coating systems to historically-painted masonry following proper surface preparation.	Failing to follow manufacturers' product and application instructions when repainting masonry features.
Repainting historically-painted masonry features with colors that are appropriate to the historic character of the building and district.	Using paint colors on historically-painted masonry features that are not appropriate to the historic character of the building and district.
Protecting adjacent materials when cleaning or removing paint from masonry features.	Failing to protect adjacent materials when cleaning or removing paint from masonry features.
Evaluating the overall condition of the masonry to determine whether more than protection and maintenance, such as repairs to masonry features, will be necessary.	Failing to undertake adequate measures to ensure the protection of masonry features.
<p>Repairing masonry by patching, splicing, consolidating, or otherwise reinforcing the masonry using recognized preservation methods. Repair may include the limited replacement in kind or with a compatible substitute material of those extensively deteriorated or missing parts of masonry features when there are surviving prototypes, such as terra-cotta brackets or stone balusters.</p>	<p>Removing masonry that could be stabilized, repaired, and conserved, or using untested consolidants and unskilled personnel, potentially causing further damage to historic materials.</p> <p>Replacing an entire masonry feature, such as a cornice or balustrade, when repair of the masonry and limited replacement of deteriorated or missing components are feasible.</p>

MASONRY: STONE, BRICK, TERRA COTTA, CONCRETE, ADOBE, STUCCO, AND MORTAR

RECOMMENDED	NOT RECOMMENDED
<p>Repairing masonry walls and other masonry features by repointing the mortar joints where there is evidence of deterioration, such as disintegrating mortar, cracks in mortar joints, loose bricks, or damaged plaster on the interior.</p>	<p>Removing non-deteriorated mortar from sound joints and then repointing the entire building to achieve a more uniform appearance.</p>
<p>Removing deteriorated lime mortar carefully by hand raking the joints to avoid damaging the masonry.</p>	
<p>Using power tools only on horizontal joints on brick masonry in conjunction with hand chiseling to remove hard mortar that is deteriorated or that is a non-historic material which is causing damage to the masonry units. Mechanical tools should be used only by skilled masons in limited circumstances and generally not on short, vertical joints in brick masonry.</p>	<p>Allowing unskilled workers to use masonry saws or mechanical tools to remove deteriorated mortar from joints prior to repointing.</p>
<p>Duplicating historic mortar joints in strength, composition, color, and texture when repointing is necessary. In some cases, a lime-based mortar may also be considered when repointing Portland cement mortar because it is more flexible.</p>	<p>Repointing masonry units with mortar of high Portland cement content (unless it is the content of the historic mortar).</p> <p>Using “surface grouting” or a “scrub” coating technique, such as a “sack rub” or “mortar washing,” to repoint exterior masonry units instead of traditional repointing methods.</p> <p>Repointing masonry units (other than concrete) with a synthetic caulking compound instead of mortar.</p>
<p>Duplicating historic mortar joints in width and joint profile when repointing is necessary.</p>	<p>Changing the width or joint profile when repointing.</p>
<p>Repairing stucco by removing the damaged material and patching with new stucco that duplicates the old in strength, composition, color, and texture.</p>	<p>Removing sound stucco or repairing with new stucco that is different in composition from the historic stucco.</p> <p>Patching stucco or concrete without removing the source of deterioration.</p> <p>Replacing deteriorated stucco with synthetic stucco, an exterior finish and insulation system (EFIS), or other non-traditional materials.</p>

MASONRY: STONE, BRICK, TERRA COTTA, CONCRETE, ADOBE, STUCCO, AND MORTAR

RECOMMENDED	NOT RECOMMENDED
Using mud plaster or a compatible lime-plaster adobe render, when appropriate, to repair adobe.	Applying cement stucco, unless it already exists, to adobe.
Sealing joints in concrete with appropriate flexible sealants and backer rods, when necessary.	
Cutting damaged concrete back to remove the source of deterioration, such as corrosion on metal reinforcement bars. The new patch must be applied carefully so that it will bond satisfactorily with and match the historic concrete.	Patching damaged concrete without removing the source of deterioration.



[5] Rebars in the reinforced concrete ceiling have rusted, causing the concrete to spall. The rebars must be cleaned of rust before the concrete can be patched.

[6] Some areas of the concrete brise soleil screen on this building constructed in 1967 are badly deteriorated. If the screen cannot be repaired, it may be replaced in kind or with a composite substitute material with the same appearance as the concrete.





[7] (a) J.W. Knapp's Department Store, built 1937-38, in Lansing, MI, was constructed with a proprietary material named "Maul Macotta" made of enameled steel and cast-in-place concrete panels. Prior to its rehabilitation, a building inspection revealed that, due to a flaw in the original design and construction, the material was deteriorated beyond repair. The architects for the rehabilitation project devised a replacement system (b) consisting of enameled aluminum panels that matched the original colors (c). Photos and drawing (a-b): Quinn Evans Architects; Photo (c): James Haefner Photography.

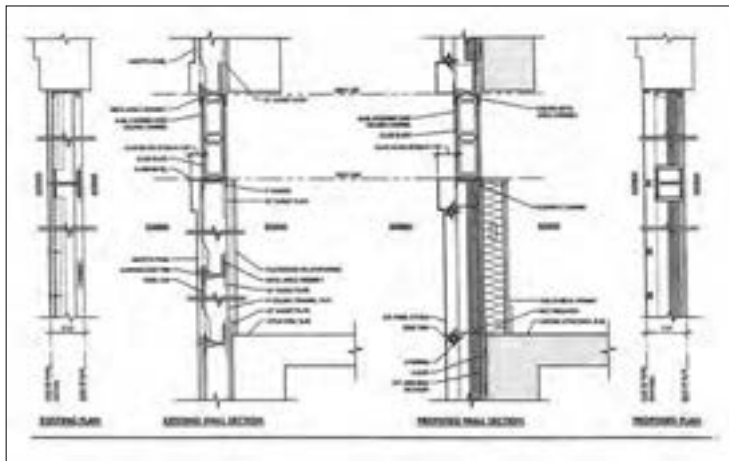

MASONRY: STONE, BRICK, TERRA COTTA, CONCRETE, ADOBE, STUCCO, AND MORTAR

RECOMMENDED	NOT RECOMMENDED
Using a non-corrosive, stainless-steel anchoring system when replacing damaged stone, concrete, or terra-cotta units that have failed.	
Applying non-historic surface treatments, such as water-repellent coatings, to masonry only after repointing and only if masonry repairs have failed to arrest water penetration problems.	Applying waterproof, water-repellent, or non-original historic coatings (such as stucco) to masonry as a substitute for repointing and masonry repairs.
Applying permeable, anti-graffiti coatings to masonry when appropriate.	Applying water-repellent or anti-graffiti coatings that change the historic appearance of the masonry or that may trap moisture if the coating is not sufficiently permeable.
Replacing in kind an entire masonry feature that is too deteriorated to repair (if the overall form and detailing are still evident) using the physical evidence as a model to reproduce the feature or when the replacement can be based on historic documentation. Examples can include large sections of a wall, a cornice, pier, or parapet. If using the same kind of material is not feasible, then a compatible substitute material may be considered.	Removing a masonry feature that is unrepairable and not replacing it, or replacing it with a new feature that does not match. Using substitute material for the replacement that does not convey the same appearance of the surviving components of the masonry feature.
<i>The following work is highlighted to indicate that it is specific to Rehabilitation projects and should only be considered after the preservation concerns have been addressed.</i>	
Designing the Replacement for Missing Historic Features	
Designing and installing a replacement masonry feature, such as a step or door pediment, when the historic feature is completely missing. It may be an accurate restoration based on documentary and physical evidence, but only when the historic feature to be replaced coexisted with the features currently on the building. Or, it may be a new design that is compatible with the size, scale, material, and color of the historic building.	Creating an inaccurate appearance because the replacement for the missing masonry feature is based upon insufficient physical or historic documentation, is not a compatible design, or because the feature to be replaced did not coexist with the features currently on the building. Introducing a new masonry feature that is incompatible in size, scale, material, or color.

WOOD: CLAPBOARD, WEATHERBOARD, SHINGLES, AND OTHER FUNCTIONAL AND DECORATIVE ELEMENTS

RECOMMENDED	NOT RECOMMENDED
<p><i>Identifying, retaining and preserving</i> wood features that are important in defining the overall historic character of the building (such as siding, cornices, brackets, window and door surrounds, and steps) and their paints, finishes, and colors.</p>	<p>Removing or substantially changing wood features which are important in defining the overall historic character of the building so that, as a result, the character is diminished.</p> <p>Removing a major portion of the historic wood from a façade instead of repairing or replacing only the deteriorated wood, then reconstructing the façade with new material to achieve a uniform or “improved” appearance.</p> <p>Changing the type of finish, coating, or historic color of wood features, thereby diminishing the historic character of the exterior.</p> <p>Failing to renew failing paint or other coatings that are historic finishes.</p> <p>Stripping historically-painted surfaces to bare wood and applying a clear finish rather than repainting.</p> <p>Stripping paint or other coatings to reveal bare wood, thereby exposing historically-coated surfaces to the effects of accelerated weathering.</p> <p>Removing wood siding (clapboards) or other covering (such as stucco) from log structures that were covered historically, which changes their historic character and exposes the logs to accelerated deterioration.</p>
<p><i>Protecting and maintaining</i> wood features by ensuring that historic drainage features that divert rainwater from wood surfaces (such as roof overhangs, gutters, and downspouts) are intact and functioning properly.</p>	<p>Failing to identify and treat the causes of wood deterioration, such as faulty flashing, leaking gutters, cracks and holes in siding, deteriorated caulking in joints and seams, plant material growing too close to wood surfaces, or insect or fungal infestation.</p>

WOOD: CLAPBOARD, WEATHERBOARD, SHINGLES, AND OTHER FUNCTIONAL AND DECORATIVE ELEMENTS

RECOMMENDED

NOT RECOMMENDED

Applying chemical preservatives or paint to wood features that are subject to weathering, such as exposed beam ends, outriggers, or rafter tails.	Using chemical preservatives (such as creosote) which, unless they were used historically, can change the appearance of wood features.
Implementing an integrated pest management plan to identify appropriate preventive measures to guard against insect damage, such as installing termite guards, fumigating, and treating with chemicals.	
Retaining coatings (such as paint) that protect the wood from moisture and ultraviolet light. Paint removal should be considered only when there is paint surface deterioration and as part of an overall maintenance program which involves repainting or applying other appropriate coatings.	Stripping paint or other coatings from wood features without recoating.



[8] Rotted clapboards have been replaced selectively with new wood siding to match the originals.

WOOD: CLAPBOARD, WEATHERBOARD, SHINGLES, AND OTHER FUNCTIONAL AND DECORATIVE ELEMENTS

RECOMMENDED	NOT RECOMMENDED
Removing damaged or deteriorated paint to the next sound layer using the gentlest method possible (e.g., hand scraping and hand sanding) prior to repainting.	Using potentially-damaging paint-removal methods on wood surfaces, such as open-flame torches, orbital sanders, abrasive methods (including sandblasting, other media blasting, or high-pressure water), or caustic paint-removers. Removing paint that is firmly adhered to wood surfaces.
Using chemical strippers primarily to supplement other methods such as hand scraping, hand sanding, and thermal devices.	Failing to neutralize the wood thoroughly after using chemical paint removers so that new paint may not adhere. Removing paint from detachable wood features by soaking them in a caustic solution, which may roughen the surface, split the wood, or result in staining from residual acids leaching out of the wood.
Using biodegradable or environmentally-safe cleaning or paint-removal products.	
Using paint-removal methods that employ a poultice to which paint adheres, when possible, to neatly and safely remove old lead paint.	
Using thermal devices (such as infrared heaters) carefully to remove paint when it is so deteriorated that total removal is necessary prior to repainting.	Using a thermal device to remove paint from wood features without first checking for and removing any flammable debris behind them. Using thermal devices without limiting the amount of time the wood feature is exposed to heat.
Using coatings that encapsulate lead paint, when possible, where the paint is not required to be removed to meet environmental regulations.	
Applying compatible paint coating systems to historically-painted wood following proper surface preparation.	Failing to follow manufacturers' product and application instructions when repainting wood features.
Repainting historically-painted wood features with colors that are appropriate to the building and district.	Using paint colors on historically-painted wood features that are not appropriate to the building or district.

WOOD: CLAPBOARD, WEATHERBOARD, SHINGLES, AND OTHER FUNCTIONAL AND DECORATIVE ELEMENTS

RECOMMENDED

NOT RECOMMENDED

Protecting adjacent materials when working on other wood features.	Failing to protect adjacent materials when working on wood features.
Evaluating the overall condition of the wood to determine whether more than protection and maintenance, such as repairs to wood features, will be necessary.	Failing to undertake adequate measures to ensure the protection of wood features.



[9] Smooth-surfaced cementitious siding (left) may be used to replace deteriorated wood siding only on secondary elevations that have minimal visibility.

[10] **Not Recommended:** Cementitious siding with a raised wood-grain texture is not an appropriate material to replace historic wood siding, which has a smooth surface when painted.



WOOD: CLAPBOARD, WEATHERBOARD, SHINGLES, AND OTHER FUNCTIONAL AND DECORATIVE ELEMENTS

RECOMMENDED	NOT RECOMMENDED
<p>Repairing wood by patching, splicing, consolidating, or otherwise reinforcing the wood using recognized conservation methods. Repair may include the limited replacement in kind or with a compatible substitute material of those extensively deteriorated or missing components of wood features when there are surviving prototypes, such as brackets, molding, or sections of siding.</p>	<p>Removing wood that could be stabilized, repaired, and conserved, or using untested consolidants and unskilled personnel, potentially causing further damage to historic materials.</p> <p>Replacing an entire wood feature, such as a cornice or balustrade, when repair of the wood and limited replacement of deteriorated or missing components is feasible.</p>
<p>Replacing in kind an entire wood feature that is too deteriorated to repair (if the overall form and detailing are still evident) using physical evidence as a model to reproduce the feature or when the replacement can be based on historic documentation. Examples of such wood features include a cornice, entablature, or a balustrade. If using wood is not feasible, then a compatible substitute material may be considered.</p>	<p>Removing a wood feature that is unrepairable and not replacing it, or replacing it with a new feature that does not match.</p> <p>Using substitute material for the replacement that does not convey the same appearance of the surviving components of the wood feature.</p>
<p>Replacing a deteriorated wood feature or wood siding on a <i>primary or other highly-visible</i> elevation with a new matching wood feature.</p>	<p>Replacing a deteriorated wood feature or wood siding on a <i>primary or other highly-visible elevation</i> with a composite substitute material.</p>
<p><i>The following work is highlighted to indicate that it is specific to Rehabilitation projects and should only be considered after the preservation concerns have been addressed.</i></p>	
<p>Designing the Replacement for Missing Historic Features</p>	
<p>Designing and installing a replacement masonry feature, such as a step or door pediment, when the historic feature is completely missing. It may be an accurate restoration based on documentary and physical evidence, but only when the historic feature to be replaced coexisted with the features currently on the building. Or, it may be a new design that is compatible with the size, scale, material, and color of the historic building.</p>	<p>Creating an inaccurate appearance because the replacement for the missing masonry feature is based upon insufficient physical or historic documentation, is not a compatible design, or because the feature to be replaced did not coexist with the features currently on the building.</p> <p>Introducing a new wood feature that is incompatible in size, scale, material, or color.</p>

METALS: WROUGHT AND CAST IRON, STEEL, PRESSED METAL, TERNEPLATE, COPPER, ALUMINUM, AND ZINC

RECOMMENDED

NOT RECOMMENDED

<p>Identifying, retaining, and preserving metal features that are important in defining the overall historic character of the building (such as columns, capitals, pilasters, spandrel panels, or stairways) and their paints, finishes, and colors. The type of metal should be identified prior to work because each metal has its own properties and may require a different treatment.</p>	<p>Removing or substantially changing metal features which are important in defining the overall historic character of the building so that, as a result, the character is diminished.</p> <p>Removing a major portion of the historic metal from a façade instead of repairing or replacing only the deteriorated metal, then reconstructing the façade with new material to achieve a uniform or “improved” appearance.</p>
<p>Protecting and maintaining metals from corrosion by providing proper drainage so that water does not stand on flat, horizontal surfaces or accumulate in curved decorative features.</p>	<p>Failing to identify and treat the causes of corrosion, such as moisture from leaking roofs or gutters.</p> <p>Placing incompatible metals together without providing an appropriate separation material. Such incompatibility can result in galvanic corrosion of the less noble metal (e.g., copper will corrode cast iron, steel, tin, and aluminum).</p>
<p>Cleaning metals when necessary to remove corrosion prior to repainting or applying appropriate protective coatings.</p>	<p>Leaving metals that must be protected from corrosion uncoated after cleaning.</p>

[11] The stainless steel doors at the entrance to this Art Deco apartment building are important in defining its historic character and should be retained in place.



METALS: WROUGHT AND CAST IRON, STEEL, PRESSED METAL, TERNEPLATE, COPPER, ALUMINUM, AND ZINC

RECOMMENDED	NOT RECOMMENDED
<p>Identifying the particular type of metal prior to any cleaning procedure and then testing to ensure that the gentlest cleaning method possible is selected; or, alternatively, determining that cleaning is inappropriate for the particular metal.</p>	<p>Using cleaning methods which alter or damage the color, texture, or finish of the metal, or cleaning when it is inappropriate for the particular metal.</p> <p>Removing the patina from historic metals. The patina may be a protective layer on some metals (such as bronze or copper) as well as a distinctive finish.</p>
<p>Using non-corrosive chemical methods to clean soft metals (such as lead, tinplate, terneplate, copper, and zinc) whose finishes can be easily damaged by abrasive methods.</p>	<p>Cleaning soft metals (such as lead, tinplate, terneplate, copper, and zinc) with abrasive methods (including sandblasting, other abrasive media, or high-pressure water) which will damage the surface of the metal.</p>
<p>Using the least abrasive cleaning method for hard metals (such as cast iron, wrought iron, and steel) to remove paint buildup and corrosion. If hand scraping and wire brushing have proven ineffective, low-pressure abrasive methods may be used as long as they do not abrade or damage the surface.</p>	<p>Using high-pressure abrasive techniques (including sandblasting, other media blasting, or high-pressure water) without first trying gentler cleaning methods prior to cleaning cast iron, wrought iron, or steel.</p>
<p>Applying appropriate paint or other coatings to historically-coated metals after cleaning to protect them from corrosion.</p>	<p>Applying paint or other coatings to metals (such as copper, bronze or stainless steel) if they were not coated historically, unless a coating is necessary for maintenance.</p>
<p>Repainting historically-painted metal features with colors that are appropriate to the building and district.</p>	<p>Using paint colors on historically-painted metal features that are not appropriate to the building or district.</p>
<p>Applying an appropriate protective coating (such as lacquer or wax) to a metal feature that was historically unpainted, such as a bronze door, which is subject to heavy use.</p>	

METALS: WROUGHT AND CAST IRON, STEEL, PRESSED METAL, TERNEPLATE, COPPER, ALUMINUM, AND ZINC

RECOMMENDED

NOT RECOMMENDED

Protecting adjacent materials when cleaning or removing paint from metal features.	Failing to protect adjacent materials when working on metal features.
Evaluating the overall condition of metals to determine whether more than protection and maintenance, such as repairs to metal features, will be necessary.	Failing to undertake adequate measures to ensure the protection of metal features.



[12] This historic steel window has been cleaned, repaired, and primed in preparation for painting and reglazing.



[13] The gold-colored, anodized aluminum geodesic dome of the former Citizen's State Bank in Oklahoma City, OK, built in 1958 and designed by Robert Roloff, makes this a distinctive mid-20th century building.



[14] Interior cast-iron columns have been cleaned and repainted as part of the rehabilitation of this historic market building for continuing use.



[15] New enameled-metal panels were replicated to replace the original panels, which were too deteriorated to repair, when the storefront of this early 1950s building was recreated.

METALS: WROUGHT AND CAST IRON, STEEL, PRESSED METAL, TERNEPLATE, COPPER, ALUMINUM, AND ZINC

RECOMMENDED

NOT RECOMMENDED

<p>Repairing metal by reinforcing the metal using recognized preservation methods. Repair may include the limited replacement in kind or with a compatible substitute material of those extensively deteriorated or missing components of features when there are surviving prototypes, such as column capitals or bases, store-fronts, railings and steps, or window hoods.</p>	<p>Removing metals that could be stabilized, repaired, and conserved, or using improper repair techniques, or unskilled personnel, potentially causing further damage to historic materials.</p>
<p>Replacing in kind an entire metal feature that is too deteriorated to repair (if the overall form and detailing are still evident) using the physical evidence as a model to reproduce the feature or when the replacement can be based on historic documentation. Examples of such a feature could include cast-iron porch steps or steel-sash windows. If using the same kind of material is not feasible, then a compatible substitute material may be considered.</p>	<p>Replacing an entire metal feature, such as a column or balustrade, when repair of the metal and limited replacement of deteriorated or missing components are feasible.</p> <p>Removing a metal feature that is unrepairable and not replacing it, or replacing it with a new metal feature that does not match.</p> <p>Using a substitute material for the replacement that does not convey the same appearance of the surviving components of the metal feature or that is physically or chemically incompatible.</p>
<p><i>The following work is highlighted to indicate that it is specific to Rehabilitation projects and should only be considered after the preservation concerns have been addressed.</i></p>	
<p>Designing the Replacement for Missing Historic Features</p>	
<p>Designing and installing a replacement metal feature, such as a metal cornice or cast-iron column, when the historic feature is completely missing. It may be an accurate restoration based on documentary and physical evidence, but only when the historic feature to be replaced coexisted with the features currently on the building. Or, it may be a new design that is compatible with the size, scale, material, and color of the historic building.</p>	<p>Creating an inaccurate appearance because the replacement for the missing metal feature is based upon insufficient physical or historic documentation, is not a compatible design, or because the feature to be replaced did not coexist with the features currently on the building.</p> <p>Introducing a new metal feature that is incompatible in size, scale, material, or color.</p>

ROOFS

RECOMMENDED	NOT RECOMMENDED
<p>Identifying, retaining, and preserving roofs and their functional and decorative features that are important in defining the overall historic character of the building. The form of the roof (gable, hipped, gambrel, flat, or mansard) is significant, as are its decorative and functional features (such as cupolas, cresting, parapets, monitors, chimneys, weather vanes, dormers, ridge tiles, and snow guards), roofing material (such as slate, wood, clay tile, metal, roll roofing, or asphalt shingles), and size, color, and patterning.</p>	<p>Removing or substantially changing roofs which are important in defining the overall historic character of the building so that, as a result, the character is diminished.</p> <p>Removing a major portion of the historic roof or roofing material that is repairable, then rebuilding it with new material to achieve a more uniform or “improved” appearance.</p> <p>Changing the configuration or shape of a roof by adding highly visible new features (such as dormer windows, vents, skylights, or a penthouse).</p> <p>Stripping the roof of sound historic material, such as slate, clay tile, wood, or metal.</p>
<p>Protecting and maintaining a roof by cleaning gutters and downspouts and replacing deteriorated flashing. Roof sheathing should also be checked for indications of moisture due to leaks or condensation.</p>	<p>Failing to clean and maintain gutters and downspouts properly so that water and debris collect and cause damage to roof features, sheathing, and the underlying roof structure.</p>
<p>Providing adequate anchorage for roofing material to guard against wind damage and moisture penetration.</p>	<p>Allowing flashing, caps, and exposed fasteners to corrode, which accelerates deterioration of the roof.</p>
<p>Protecting a leaking roof with a temporary waterproof membrane with a synthetic underlayment, roll roofing, plywood, or a tarpaulin until it can be repaired.</p>	<p>Leaving a leaking roof unprotected so that accelerated deterioration of historic building materials (such as masonry, wood, plaster, paint, and structural members) occurs.</p>
<p>Repainting a roofing material that requires a protective coating and was painted historically (such as a terneplate metal roof or gutters) as part of regularly-scheduled maintenance.</p>	<p>Failing to repaint a roofing material that requires a protective coating and was painted historically as part of regularly-scheduled maintenance.</p>
<p>Applying compatible paint coating systems to historically-painted roofing materials following proper surface preparation.</p>	<p>Applying paint or other coatings to roofing material if they were not coated historically.</p>
<p>Protecting a roof covering when working on other roof features.</p>	<p>Failing to protect roof coverings when working on other roof features.</p>
<p>Evaluating the overall condition of the roof and roof features to determine whether more than protection and maintenance, such as repairs to roof features, will be necessary.</p>	<p>Failing to undertake adequate measures to ensure the protection of roof features.</p>

ROOFS

RECOMMENDED

Repairing a roof by ensuring that the existing historic or compatible non-historic roof covering is sound and waterproof. Repair may include the limited replacement in kind or with a compatible substitute material of missing materials (such as wood shingles, slates, or tiles) on a main roof, as well as those extensively deteriorated or missing components of features when there are surviving prototypes, such as ridge tiles, dormer roofing, or roof monitors.

Using corrosion-resistant roof fasteners (e.g., nails and clips) to repair a roof to help extend its longevity.

NOT RECOMMENDED

Replacing an entire roof feature when repair of the historic roofing materials and limited replacement of deteriorated or missing components are feasible.



[16] The deteriorated asphalt shingles of this porch roof are being replaced in kind with matching shingles.

ROOFS

RECOMMENDED	NOT RECOMMENDED
<p>Replacing in kind an entire roof covering or feature that is too deteriorated to repair (if the overall form and detailing are still evident) using the physical evidence as a model to reproduce the feature or when the replacement can be based on historic documentation. Examples of such a feature could include a large section of roofing, a dormer, or a chimney. If using the same kind of material is not feasible, then a compatible substitute material may be considered.</p>	<p>Removing a feature of the roof that is unrepairable and not replacing it, or replacing it with a new roof feature that does not match.</p> <p>Using a substitute material for the replacement that does not convey the same appearance of the roof covering or the surviving components of the roof feature or that is physically or chemically incompatible.</p>
<p>Replacing only missing or damaged roofing tiles or slates rather than replacing the entire roof covering.</p>	<p>Failing to reuse intact slate or tile in good condition when only the roofing substrate or fasteners need replacement.</p>
<p>Replacing an incompatible roof covering or any deteriorated non-historic roof covering with historically-accurate roofing material, if known, or another material that is compatible with the historic character of the building.</p>	
<p><i>The following work is highlighted to indicate that it is specific to Rehabilitation projects and should only be considered after the preservation concerns have been addressed.</i></p>	
Designing the Replacement for Missing Historic Features	
<p>Designing and installing a new roof covering for a missing roof or a new feature, such as a dormer or a monitor, when the historic feature is completely missing. It may be an accurate restoration based on documentary and physical evidence, but only when the historic feature to be replaced coexisted with the features currently on the building. Or, it may be a new design that is compatible with the size, scale, material, and color of the historic building.</p>	<p>Creating an inaccurate appearance because the replacement for the missing roof feature is based upon insufficient physical or historic documentation, is not a compatible design, or because the feature to be replaced did not coexist with the features currently on the building.</p> <p>Introducing a new roof feature that is incompatible in size, scale, material, or color.</p>

ROOFS

RECOMMENDED

NOT RECOMMENDED

Alterations and Additions for a New Use

Installing mechanical and service equipment on the roof (such as heating and air-conditioning units, elevator housing, or solar panels) when required for a new use so that they are inconspicuous on the site and from the public right-of-way and do not damage or obscure character-defining historic features.	Installing roof-top mechanical or service equipment so that it damages or obscures character-defining roof features or is conspicuous on the site or from the public right-of-way.
Designing rooftop additions, elevator or stair towers, decks or terraces, dormers, or skylights when required by a new or continuing use so that they are inconspicuous and minimally visible on the site and from the public right-of-way and do not damage or obscure character-defining historic features.	Changing a character-defining roof form, or damaging or destroying character-defining roofing material as a result of an incompatible rooftop addition or improperly-installed or highly-visible mechanical equipment.
Installing a green roof or other roof landscaping, railings, or furnishings that are not visible on the site or from the public right-of-way and do not damage the roof structure.	Installing a green roof or other roof landscaping, railings, or furnishings that are visible on the site and from the public right-of-way.

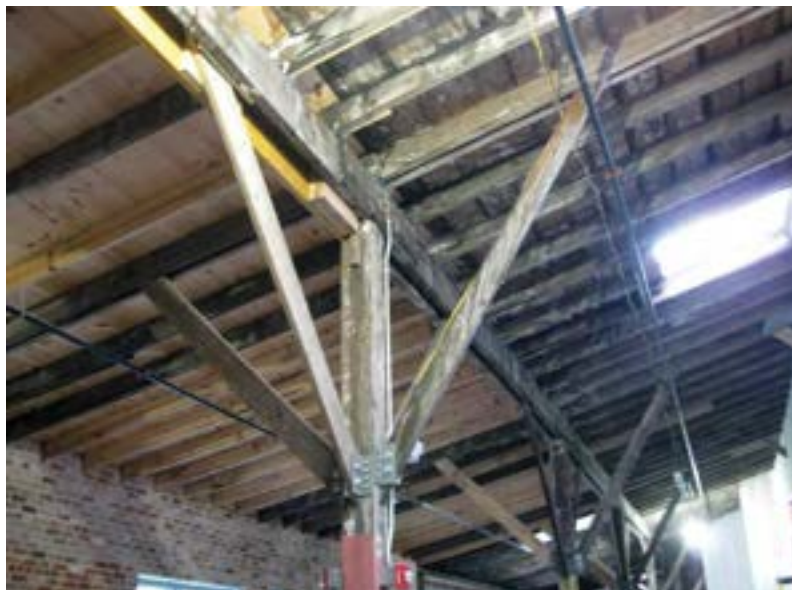

[17] New wood elements have been used selectively to replace rotted wood on the underside of the roof in this historic warehouse.

WINDOWS

RECOMMENDED	NOT RECOMMENDED
<p>Identifying, retaining, and preserving windows and their functional and decorative features that are important to the overall character of the building. The window material and how the window operates (e.g., double hung, casement, awning, or hopper) are significant, as are its components (including sash, muntins, ogee lugs, glazing, pane configuration, sills, mullions, casings, or brick molds) and related features, such as shutters.</p>	<p>Removing or substantially changing windows or window features which are important in defining the overall historic character of the building so that, as a result, the character is diminished.</p> <p>Changing the appearance of windows that contribute to the historic character of the building by replacing materials, finishes, or colors which noticeably change the sash, depth of the reveal, and muntin configurations; the reflectivity and color of the glazing; or the appearance of the frame.</p> <p>Obscuring historic wood window trim with metal or other material.</p> <p>Replacing windows solely because of peeling paint, broken glass, stuck sash, or high air infiltration. These conditions, in themselves, do not indicate that windows are beyond repair.</p>
<p>Protecting and maintaining the wood or metal which comprises the window jamb, sash, and trim through appropriate treatments, such as cleaning, paint removal, and reapplication of protective coating systems.</p>	<p>Failing to protect and maintain window materials on a cyclical basis so that deterioration of the window results.</p>
<p>Protecting windows against vandalism before work begins by covering them and by installing alarm systems that are keyed into local protection agencies.</p>	<p>Leaving windows unprotected and subject to vandalism before work begins, thereby also allowing the interior to be damaged if it can be accessed through unprotected windows.</p>
<p>Making windows weathertight by recaulking gaps in fixed joints and replacing or installing weatherstripping.</p>	
<p>Protecting windows from chemical cleaners, paint, or abrasion during work on the exterior of the building.</p>	<p>Failing to protect historic windows from chemical cleaners, paint, or abrasion when work is being done on the exterior of the building.</p>
<p>Protecting and retaining historic glass when replacing putty or repairing other components of the window.</p>	<p>Failing to protect the historic glass when making window repairs.</p>

WINDOWS

RECOMMENDED	NOT RECOMMENDED
Sustaining the historic operability of windows by lubricating friction points and replacing broken components of the operating system (such as hinges, latches, sash chains or cords) and replacing deteriorated gaskets or insulating units.	Failing to maintain windows and window components so that windows are inoperable, or sealing operable sash permanently.
Adding storm windows with a matching or a one-over-one pane configuration that will not obscure the characteristics of the historic windows. Storm windows improve energy efficiency and are especially beneficial when installed over wood windows because they also protect them from accelerated deterioration.	Failing to repair and reuse window hardware such as sash lifts, latches, and locks.
Adding interior storm windows as an alternative to exterior storm windows when appropriate.	



[18] The historic metal storm windows in this 1920s office building were retained and repaired during the rehabilitation project.



[19] Installing a mockup of a proposed replacement window can be helpful to evaluate how well the new windows will match the historic windows that are missing or too deteriorated to repair.



[20 a-d] The original steel windows in this industrial building were successfully repaired as part of the rehabilitation project (left).

WINDOWS

RECOMMENDED	NOT RECOMMENDED
Installing sash locks, window guards, removable storm windows, and other reversible treatments to meet safety, security, or energy conservation requirements.	
Evaluating the overall condition of the windows to determine whether more than protection and maintenance, such as repairs to windows and window features, will be necessary.	Failing to undertake adequate measures to ensure the protection of window features.
Repairing window frames and sash by patching, splicing, consolidating, or otherwise reinforcing them using recognized preservation methods. Repair may include the limited replacement in kind or with a compatible substitute material of those extensively deteriorated, broken, or missing components of features when there are surviving prototypes, such as sash, sills, hardware, or shutters.	Removing window features that could be stabilized, repaired, or conserved using untested consolidants, improper repair techniques, or unskilled personnel, potentially causing further damage to the historic materials. Replacing an entire window when repair of the window and limited replacement of deteriorated or missing components are feasible.
Removing glazing putty that has failed and applying new putty; or, if glass is broken, carefully removing all putty, replacing the glass, and reputtying.	
Installing new glass to replace broken glass which has the same visual characteristics as the historic glass.	
Replacing in kind an entire window that is too deteriorated to repair (if the overall form and detailing are still evident) using the physical evidence as a model to reproduce the feature or when the replacement can be based on historic documentation. If using the same kind of material is not feasible, then a compatible substitute material may be considered.	Removing a character-defining window that is unrepairable or is not needed for the new use and blocking up the opening, or replacing it with a new window that does not match. Using substitute material for the replacement that does not convey the same appearance of the surviving components of the window or that is physically incompatible.

WINDOWS



[21] The windows on the lower floor, which were too deteriorated to repair, were replaced with new steel windows matching the upper-floor historic windows that were retained.

RECOMMENDED	NOT RECOMMENDED
Modifying a historic single-glazed sash to accommodate insulated glass when it will not jeopardize the soundness of the sash or significantly alter its appearance.	Modifying a historic single-glazed sash to accommodate insulated glass when it will jeopardize the soundness of the sash or significantly alter its appearance.
Using low-e glass with the least visible tint in new or replacement windows.	Using low-e glass with a dark tint in new or replacement windows, thereby negatively impacting the historic character of the building.
Using window grids rather than true divided lights on windows on the upper floors of high-rise buildings if they will not be noticeable.	Using window grids rather than true divided lights on windows in low-rise buildings or on lower floors of high-rise buildings where they will be noticeable, resulting in a change to the historic character of the building.
Ensuring that spacer bars in between double panes of glass are the same color as the window sash.	Using spacer bars in between double panes of glass that are not the same color as the window sash.
Replacing all of the components in a glazing system if they have failed because of faulty design or materials that have deteriorated with new material that will improve the window performance without noticeably changing the historic appearance.	Replacing all of the components in a glazing system with new material that will noticeably change the historic appearance.
Replacing incompatible, non-historic windows with new windows that are compatible with the historic character of the building; or reinstating windows in openings that have been filled in.	
<i>The following work is highlighted to indicate that it is specific to Rehabilitation projects and should only be considered after the preservation concerns have been addressed.</i>	
Designing the Replacement for Missing Historic Features	
Designing and installing a new window or its components, such as frames, sash, and glazing, when the historic feature is completely missing. It may be an accurate restoration based on documentary and physical evidence, but only when the historic feature to be replaced coexisted with the features currently on the building. Or, it may be a new design that is compatible with the size, scale, material, and color of the historic building.	<p>Creating an inaccurate appearance because the replacement for the missing window is based upon insufficient physical or historic documentation, is not a compatible design, or because the feature to be replaced did not coexist with the features currently on the building.</p> <p>Installing replacement windows made from other materials that are not the same as the material of the original windows if they would have a noticeably different appearance from the remaining historic windows.</p>



(a)



(b)



(c)

[22] **Not Recommended:** (a-b) The original wood windows in this late-19th-century building, which were highly decorative, could likely have been repaired and retained. (c) Instead, they were replaced with new windows that do not match the detailing of the historic windows and, therefore, do not meet the Standards (above).



[23] (a) This deteriorated historic wood window was repaired and retained (b) in this rehabilitation project.



WINDOWS

RECOMMENDED

NOT RECOMMENDED

Alterations and Additions for a New Use

Adding new window openings on rear or other secondary, less-visible elevations, if required by a new use. The new openings and the windows in them should be compatible with the overall design of the building but, in most cases, not duplicate the historic fenestration.

Changing the number, location, size, or glazing pattern of windows on primary or highly-visible elevations which will alter the historic character of the building.

Cutting new openings on character-defining elevations or cutting new openings that damage or destroy significant features.

Adding balconies at existing window openings or new window openings on primary or other highly-visible elevations where balconies never existed and, therefore, would be incompatible with the historic character of the building.

Replacing windows that are too deteriorated to repair using the same sash and pane configuration, but with new windows that operate differently, if necessary, to accommodate a new use. Any change must have minimal visual impact. Examples could include replacing hopper or awning windows with casement windows, or adding a realigned and enlarged operable portion of industrial steel windows to meet life-safety codes.

Replacing a window that contributes to the historic character of the building with a new window that is different in design (such as glass divisions or muntin profiles), dimensions, materials (wood, metal, or glass), finish or color, or location that will have a noticeably different appearance from the historic windows, which may negatively impact the character of the building.

Installing impact-resistant glazing, when necessary for security, so that it is compatible with the historic windows and does not damage them or negatively impact their character.

Installing impact-resistant glazing, when necessary for security, that is incompatible with the historic windows and that damages them or negatively impacts their character.

Using compatible window treatments (such as frosted glass, appropriate shades or blinds, or shutters) to retain the historic character of the building when it is necessary to conceal mechanical equipment, for example, that the new use requires be placed in a location behind a window or windows on a primary or highly-visible elevation.

Removing a character-defining window to conceal mechanical equipment or to provide privacy for a new use of the building by blocking up the opening.

ENTRANCES AND PORCHES

RECOMMENDED

NOT RECOMMENDED



[24] Rotted boards in the beaded-board porch ceiling are being replaced with new matching beaded board.

<p>Identifying, retaining, and preserving entrances and porches and their functional and decorative features that are important in defining the overall historic character of the building. The materials themselves (including masonry, wood, and metal) are significant, as are their features, such as doors, transoms, pilasters, columns, balustrades, stairs, roofs, and projecting canopies.</p>	<p>Removing or substantially changing entrances and porches which are important in defining the overall historic character of the building so that, as a result, the character is diminished.</p> <p>Cutting new entrances on a primary façade.</p> <p>Altering utilitarian or service entrances so they compete visually with the historic primary entrance; increasing their size so that they appear significantly more important; or adding decorative details that cannot be documented to the building or are incompatible with the building's historic character.</p>
<p>Retaining a historic entrance or porch even though it will no longer be used because of a change in the building's function.</p>	<p>Removing a historic entrance or porch that will no longer be required for the building's new use.</p>
<p>Protecting and maintaining the masonry, wood, and metals which comprise entrances and porches through appropriate surface treatments, such as cleaning, paint removal, and reapplication of protective coating systems.</p>	<p>Failing to protect and maintain entrance and porch materials on a cyclical basis so that deterioration of entrances and porches results.</p>
<p>Protecting entrances and porches against arson and vandalism before work begins by covering them and by installing alarm systems keyed into local protection agencies.</p>	<p>Leaving entrances and porches unprotected and subject to vandalism before work begins, thereby also allowing the interior to be damaged if it can be accessed through unprotected entrances.</p>
<p>Protecting entrance and porch features when working on other features of the building.</p>	<p>Failing to protect materials and features when working on other features of the building.</p>
<p>Evaluating the overall condition of entrances and porches to determine whether more than protection and maintenance, such as repairs to entrance and porch features, will be necessary.</p>	<p>Failing to undertake adequate measures to ensure the protection of entrance and porch features.</p>
<p>Repairing entrances and porches by patching, splicing, consolidating, and otherwise reinforcing them using recognized preservation methods. Repair may include the limited replacement in kind or with a compatible substitute material of those extensively deteriorated features or missing components of features when there are surviving prototypes, such as balustrades, columns, and stairs.</p>	<p>Removing entrances and porches that could be stabilized, repaired, and conserved, or using untested consolidants, improper repair techniques, or unskilled personnel, potentially causing further damage to historic materials.</p> <p>Replacing an entire entrance or porch feature when repair of the feature and limited replacement of deteriorated or missing components are feasible.</p>

ENTRANCES AND PORCHES

RECOMMENDED

Replacing in kind an entire entrance or porch that is too deteriorated to repair (if the overall form and detailing are still evident) using the physical evidence as a model to reproduce the feature or when the replacement can be based on historic documentation. If using the same kind of material is not feasible, then a compatible substitute material may be considered.

NOT RECOMMENDED

Removing an entrance or porch that is unrepairable and not replacing it, or replacing it with a new entrance or porch that does not match.

Using a substitute material for the replacement that does not convey the same appearance of the surviving components of entrance or porch features or that is physically incompatible.



[25] The new infill designs for the garage door openings in this commercial building (a) converted for restaurant use and in this mill building (b) rehabilitated for residential use are compatible with the historic character of the buildings.

ENTRANCES AND PORCHES

RECOMMENDED	NOT RECOMMENDED
<i>The following work is highlighted to indicate that it is specific to Rehabilitation projects and should only be considered after the preservation concerns have been addressed.</i>	
Designing the Replacement for Missing Historic Features	
<p>Designing and installing a new entrance or porch when the historic feature is completely missing or has previously been replaced by one that is incompatible. It may be an accurate restoration based on documentary and physical evidence, but only when the historic entrance or porch to be replaced coexisted with the features currently on the building. Or, it may be a new design that is compatible with the size, scale, material, and color of the historic building.</p>	<p>Creating an inaccurate appearance because the replacement for the missing entrance or porch is based upon insufficient physical or historic documentation, is not a compatible design, or because the feature to be replaced did not coexist with the features currently on the building.</p>
Alterations and Additions for a New Use	
<p>Enclosing historic porches on secondary elevations only, when required by a new use, in a manner that preserves the historic character of the building (e.g., using large sheets of glass and recessing the enclosure wall behind existing posts and balustrades).</p>	<p>Enclosing porches in a manner that results in a diminution or loss of historic character by using solid materials rather than clear glazing, or by placing the enclosure in front of, rather than behind, the historic features.</p>
<p>Designing and constructing additional entrances or porches on secondary elevations when required for the new use in a manner that preserves the historic character of the building (i.e., ensuring that the new entrance or porch is clearly subordinate to historic primary entrances or porches).</p>	<p>Constructing secondary or service entrances and porches that are incompatible in size and scale or detailing with the historic building or that obscure, damage, or destroy character-defining features.</p>

[26] **Not Recommended:** Installing a screened enclosure is never recommended on a front or otherwise prominent historic porch. In limited instances, it may be possible to add screening on a porch at the rear or on a secondary façade; however, the enclosure should match the color of the porch and be placed behind columns and railings so that it does not obscure these features.



STOREFRONTS

RECOMMENDED

Identifying, retaining, and preserving storefronts and their functional and decorative features that are important in defining the overall historic character of the building. The storefront materials (including wood, masonry, metals, ceramic tile, clear glass, and pigmented structural glass) and the configuration of the storefront are significant, as are features, such as display windows, base panels, bulkheads, signs, doors, transoms, kick plates, corner posts, piers, and entablatures. The removal of inappropriate, non-historic cladding, false mansard roofs, and other later, non-significant alterations can help reveal the historic character of the storefront.

Retaining later, non-original features that have acquired significance over time.

NOT RECOMMENDED

Removing or substantially changing storefronts and their features which are important in defining the overall historic character of the building so that, as a result, the character is diminished.

Changing the storefront so that it has a residential rather than commercial appearance.

Introducing features from an earlier period that are not compatible with the historic character of the storefront.

Changing the location of the storefront's historic main entrance.

Replacing or covering a glass transom with solid material or inappropriate signage, or installing an incompatible awning over it.

Removing later features that may have acquired significance.



[28] This new storefront, which replaced one that was missing, is compatible with the historic character of the building.

STOREFRONTS

RECOMMENDED	NOT RECOMMENDED
<p><i>Protecting and maintaining</i> masonry, wood, glass, ceramic tile, and metals which comprise storefronts through appropriate treatments, such as cleaning, paint removal, and reapplication of protective coating systems.</p>	<p>Failing to protect and maintain storefront materials on a cyclical basis so that deterioration of storefront features results.</p>
<p>Protecting storefronts against arson and vandalism before work begins by covering windows and doors and by installing alarm systems keyed into local protection agencies.</p>	<p>Leaving the storefront unprotected and subject to vandalism before work begins, thereby also allowing the interior to be damaged if it can be accessed through unprotected entrances.</p>
<p>Protecting the storefront when working on other features of the building.</p>	<p>Failing to protect the storefront when working on other features of the building.</p>
<p>Evaluating the overall condition of the storefront to determine whether more than protection and maintenance, such as repairs to storefront features, will be necessary.</p>	<p>Failing to undertake adequate measures to ensure the protection of storefront features.</p>



[27] This original c. 1940s storefront, with its character-defining angled and curved glass display window and recessed entrance with a decorative terrazzo paving, is in good condition and should be retained in a rehabilitation project.

STOREFRONTS

RECOMMENDED

NOT RECOMMENDED

Repairing storefronts by patching, splicing, consolidating, or otherwise reinforcing them using recognized preservation methods. Repair may include the limited replacement in kind or with a compatible substitute material of those extensively deteriorated or missing components of storefronts when there are surviving prototypes, such as transoms, base panels, kick plates, piers, or signs.

Removing storefronts that could be stabilized, repaired, and conserved, or using untested consolidants, improper repair techniques, or unskilled personnel, potentially causing further damage to historic materials.

Replacing in kind an entire storefront that is too deteriorated to repair (if the overall form and detailing are still evident) using the physical evidence as a model to reproduce the feature or when the replacement can be based on historic documentation. If using the same kind of material is not feasible, then a compatible substitute material may be considered.

Replacing a storefront feature when repair of the feature and limited replacement of deteriorated or missing components are feasible.

Using a substitute material for the replacement that does not convey the same appearance of the surviving components of the storefront or that is physically incompatible.

Removing a storefront that is unrepairable and not replacing it or replacing it with a new storefront that does not match.

The following work is highlighted to indicate that it is specific to Rehabilitation projects and should only be considered after the preservation concerns have been addressed.

Designing the Replacement for Missing Historic Features

Designing and installing a new storefront when the historic storefront is completely missing or has previously been replaced by one that is incompatible. It may be an accurate restoration based on documentary and physical evidence, but only when the historic storefront to be replaced coexisted with the features currently on the building. Or, it may be a new design that is compatible with the size, scale, material, and color of the historic building.

Creating an inaccurate appearance because the replacement for the missing storefront is based upon insufficient physical or historic documentation, is not a compatible design, or because the feature to be replaced did not coexist with the features currently on the building.

Using new, over-scaled, or internally-lit signs unless there is a historic precedent for them or using other types of signs that obscure, damage, or destroy character-defining features of the storefront and the building.

STOREFRONTS

RECOMMENDED	NOT RECOMMENDED
<p>Replacing missing awnings or canopies that can be historically documented to the building, or adding new signage, awnings, or canopies that are compatible with the historic character of the building.</p>	<p>Adding vinyl awnings, or other awnings that are inappropriately sized or shaped, which are incompatible with the historic character of the building; awnings that do not extend over the entire length of the storefront; or large canopies supported by posts that project out over the sidewalk, unless their existence can be historically documented.</p>
Alterations and Additions for a New Use	
<p>Retaining the glazing and the transparency (i.e., which allows the openness of the interior to be experienced from the exterior) that is so important in defining the character of a historic storefront when the building is being converted for residential use. Window treatments (necessary for occupants' privacy) should be installed that are uniform and compatible with the commercial appearance of the building, such as screens or wood blinds. When display cases still exist behind the storefront, the screening should be set at the back of the display case.</p>	<p>Replacing storefront glazing with solid material for occupants' privacy when the building is being converted for residential use.</p> <p>Installing window treatments in storefront windows that have a residential appearance, which are incompatible with the commercial character of the building.</p> <p>Installing window treatments that are not uniform in a series of repetitive storefront windows.</p>



[29] The rehabilitation of the 1910 Māālaea General Store (a), which served the workers' camp at the Wailuku Sugar Company on the Hawaiian island of Maui, included the reconstruction of the original parapet (b).



CURTAIN WALLS

RECOMMENDED	NOT RECOMMENDED
<p>Identifying, retaining, and preserving curtain wall systems and their components (metal framing members and glass or opaque panels) that are important in defining the overall historic character of the building. The design of the curtain wall is significant, as are its component materials (metal stick framing and panel materials, such as clear or spandrel glass, stone, terra cotta, metal, and fiber-reinforced plastic), appearance (e.g., glazing color or tint, transparency, and reflectivity), and whether the glazing is fixed, operable or louvered glass panels. How a curtain wall is engineered and fabricated, and the fact that it expands and contracts at a different rate from the building's structural system, are important to understand when undertaking the rehabilitation of a curtain wall system.</p>	<p>Removing or substantially changing curtain wall components which are important in defining the overall historic character of the building so that, as a result, the character is diminished.</p> <p>Replacing historic curtain wall features instead of repairing or replacing only the deteriorated components.</p>
<p>Protecting and maintaining curtain walls and their components through appropriate surface treatments, such as cleaning, paint removal, and reapplication of protective coating systems; and by making them watertight and ensuring that sealants and gaskets are in good condition.</p>	<p>Failing to protect and maintain curtain wall components on a cyclical basis so that deterioration of curtain walls results.</p> <p>Failing to identify, evaluate, and treat various causes of curtain wall failure, such as open gaps between components where sealants have deteriorated or are missing.</p>
<p>Protecting ground-level curtain walls from vandalism before work begins by covering them, while ensuring adequate ventilation, and by installing alarm systems keyed into local protection agencies.</p>	<p>Leaving ground-level curtain walls unprotected and subject to vandalism before work begins, thereby also allowing the interior to be damaged if it can be accessed through unprotected glazing.</p>
<p>Protecting curtain walls when working on other features of the building.</p>	<p>Failing to protect curtain walls when working on other features of the building.</p>
<p>Cleaning curtain wall systems only when necessary to halt deterioration or to remove heavy soiling.</p>	<p>Cleaning curtain wall systems when they are not heavily soiled, thereby needlessly introducing chemicals or moisture into historic materials.</p>

CURTAIN WALLS

RECOMMENDED	NOT RECOMMENDED
Carrying out cleaning tests, when it has been determined that cleaning is appropriate, using only cleaning materials that will not damage components of the system, including factory-applied finishes. Test areas should be examined to ensure that no damage has resulted.	Cleaning curtain wall systems without testing or using cleaning materials that may damage components of the system.
Evaluating the overall condition of curtain walls to determine whether more than protection and maintenance, such as repair of curtain wall components, will be necessary.	Failing to undertake adequate measures to protect curtain wall components.
Repairing curtain walls by ensuring that they are watertight by augmenting existing components or replacing deteriorated or missing sealants or gaskets, where necessary, to seal any gaps between system components. Repair may include the limited replacement of those extensively deteriorated or missing components of curtain walls when there are surviving prototypes.	Removing curtain wall components that could be repaired or using improper repair techniques. Replacing an entire curtain wall system when repair of materials and limited replacement of deteriorated or missing components are feasible.
Applying sealants carefully so that they are not readily visible.	
Replacing in kind a component or components of a curtain wall system that are too deteriorated to repair (if the overall form and detailing are still evident) using the physical evidence as a model to reproduce the feature. If using the same kind of material is not feasible, then a compatible substitute material may be considered as long as it has the same finish and appearance.	Removing a curtain wall component or the entire system, if necessary, that is unrepairable and not replacing it or replacing it with a new component or system that does not convey the same appearance.
Replacing masonry, metal, glass, or other components of a curtain wall system (or the entire system, if necessary) which have failed because of faulty design with substitutes that match the original as closely as possible and which will reestablish the viability and performance of the system.	Using substitute material for the replacement that does not convey the same appearance of the surviving components of the curtain wall or that is physically incompatible.



[30] Rather than replace the original curtain wall system of the 1954 Simms Building in Albuquerque, NM, with a different color tinted glass or coat it with a non-historic reflective film, the HVAC system was updated to improve energy efficiency. Photo: Harvey M. Kaplan.

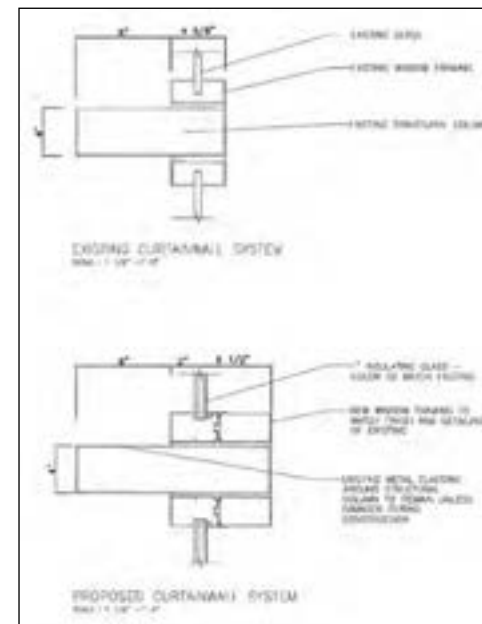

[31 a-c:] (a) The rehabilitation of the First Federal Savings and Loan Association building in Birmingham, AL, constructed in 1961, required replacing the deteriorated historic curtain wall system because the framing and the fasteners holding the spandrel glass and the windows had failed. (b) Comparative drawings show that the differences between the replacement system, which incorporated new insulated glass to meet wind-load requirements, and the original system are minimal. (c) The replacement system, shown after completion of the project, has not altered the historic character of the building.



CURTAIN WALLS

RECOMMENDED

NOT RECOMMENDED

The following work is highlighted to indicate that it is specific to Rehabilitation projects and should only be considered after the preservation concerns have been addressed.

Designing the Replacement for Missing Historic Features

Designing and installing a new curtain wall or its components when the historic feature is completely missing. It may be an accurate restoration based on documentary and physical evidence, but only when the historic feature to be replaced coexisted with the features currently on the building. Or, it may be a new design that is compatible with the size, scale, material, and color of the historic building.

Creating an inaccurate appearance because the replacement for the missing curtain wall component is based upon insufficient physical or historic documentation, is not a compatible design, or because the feature did not coexist with the features currently on the building.

Introducing a new curtain wall component that is incompatible in size, scale, material, color, and finish.

Alterations and Additions for a New Use

Installing new glazing or an entire new curtain wall system, when necessary to meet safety-code requirements, with dimensions, detailing, materials, colors, and finish as close as possible to the historic curtain wall components.

Installing new glazing or an entire new curtain wall system, when necessary to meet safety-code requirements, with dimensions and detailing that is significantly different from the historic curtain wall components.

Installing impact-resistant glazing, when necessary for security, so that it is compatible with the historic windows and does not damage them or negatively impact their character.

Installing impact-resistant glazing in a curtain wall system, when necessary for security, that is incompatible with the historic curtain walls and damages them or negatively impacts their character.

STRUCTURAL SYSTEMS

RECOMMENDED

NOT RECOMMENDED

Identifying, retaining, and preserving structural systems and visible features of systems that are important in defining the overall historic character of the building. This includes the materials that comprise the structural system (i.e., wood, metal and masonry), the type of system, and its features, such as posts and beams, trusses, summer beams, vigas, cast-iron or masonry columns, above-grade stone foundation walls, or load-bearing masonry walls.

Removing or substantially changing visible features of historic structural systems which are important in defining the overall historic character of the building so that, as a result, the character is diminished.

Overloading the existing structural system, or installing equipment or mechanical systems which could damage the structure.

Replacing a load-bearing masonry wall that could be augmented and retained.

Leaving known structural problems untreated, such as deflected beams, cracked and bowed walls, or racked structural members.

Protecting and maintaining the structural system by keeping gutters and downspouts clear and roofing in good repair; and by ensuring that wood structural members are free from insect infestation.

Failing to protect and maintain the structural system on a cyclical basis so that deterioration of the structural system results.

Using treatments or products that may retain moisture, which accelerates deterioration of structural members.

[33] Retaining as much as possible of the historic wood sill plate and replacing only the termite-damaged wood is always the preferred and recommended treatment.



STRUCTURAL SYSTEMS

RECOMMENDED	NOT RECOMMENDED
Evaluating the overall condition of the structural system to determine whether more than protection and maintenance, such as repairs to structural features, will be necessary.	Failing to undertake adequate measures to ensure the protection of structural systems.
Repairing the structural system by augmenting individual components, using recognized preservation methods. For example, weakened structural members (such as floor framing) can be paired or sistered with a new member, braced, or otherwise supplemented and reinforced.	Upgrading the building structurally in a manner that diminishes the historic character of the exterior or that damages interior features or spaces.
	Replacing a historic structural feature in its entirety or in part when it could be repaired or augmented and retained.



[32] (a-b) The rehabilitation of the 1892 Carson Block Building in Eureka, CA, for its owner, the Northern California Indian Development Council, included recreating the missing corner turret and sensitively introducing seismic reinforcement (c) shown here (opposite page) in a secondary upper floor office space. *Photos: Page & Turnbull.*

STRUCTURAL SYSTEMS

RECOMMENDED	NOT RECOMMENDED
Installing seismic or structural reinforcement, when necessary, in a manner that minimizes its impact on the historic fabric and character of the building.	
Replacing in kind or with a compatible substitute material large portions or entire features of the structural system that are either extensively damaged or deteriorated or that are missing when there are surviving prototypes, such as cast-iron columns, trusses, or masonry walls. Substitute material must be structurally sufficient, physically compatible with the rest of the system, and, where visible, must have the same form, design, and appearance as the historic feature.	Using substitute material that does not equal the load-bearing capabilities of the historic material; does not convey the same appearance of the historic material, if it is visible; or is physically incompatible. Installing a visible or exposed structural replacement feature that does not match.
Replacing to match any interior features or finishes that may have to be removed to gain access to make structural repairs, and reusing salvageable material.	



STRUCTURAL SYSTEMS

RECOMMENDED

NOT RECOMMENDED

The following work is highlighted to indicate that it is specific to Rehabilitation projects and should only be considered after the preservation concerns have been addressed.

Alterations and Additions for a New Use

<p>Limiting any new excavations next to historic foundations to avoid undermining the structural stability of the building or adjacent historic buildings. The area next to the building foundation should be investigated first to ascertain potential damage to site features or archeological resources.</p>	<p>Carrying out excavations or regrading land adjacent to a historic building which could cause the historic foundation to settle, shift, or fail, or which could destroy significant archeological resources.</p>
<p>Correcting structural deficiencies needed to accommodate a new use in a manner that preserves the structural system and individual character-defining features.</p>	<p>Making substantial changes to significant interior spaces or damaging or destroying features or finishes that are character defining to correct structural deficiencies.</p>
<p>Designing and installing new mechanical or electrical equipment, when necessary, in a manner that minimizes the number and size of cuts or holes in structural members.</p>	<p>Installing new mechanical or electrical equipment in a manner which reduces the load-bearing capacity of historic structural members.</p>
<p>Inserting a new floor when required for the new use if it does not negatively impact the historic character of the interior space; and if it does not damage the structural system, does not abut window glazing, and is not visible from the exterior of the building.</p>	<p>Inserting a new floor that damages or destroys the structural system or abuts window glazing and is visible from the exterior of the building and, thus, negatively impacts its historic character.</p>
<p>Creating an atrium, light court, or lightwell to provide natural light when required for a new use only when it can be done in a manner that preserves the structural system and the historic character of the building.</p>	<p>Removing structural features to create an atrium, light court, or lightwell if it negatively impacts the historic character of the building.</p>

MECHANICAL SYSTEMS: HEATING, AIR CONDITIONING, ELECTRICAL, AND PLUMBING

RECOMMENDED	NOT RECOMMENDED
Identifying, retaining, and preserving visible features of early mechanical systems that are important in defining the overall historic character of the building, such as radiators, vents, fans, grilles, and plumbing and lighting fixtures.	Removing or substantially changing visible features of mechanical systems that are important in defining the overall historic character of the building so that, as a result, the character is diminished.
Protecting and maintaining mechanical, plumbing, and electrical systems and their features through cyclical maintenance.	Failing to protect and maintain a functioning mechanical system, plumbing, and electrical systems and their visible features on a cyclical basis so that their deterioration results.
Improving the energy efficiency of existing mechanical systems to help reduce the need for a new system by installing storm windows, insulating attics and crawl spaces, or adding awnings, if appropriate.	
Evaluating the overall condition of mechanical systems to determine whether more than protection and maintenance, such as repairs to mechanical system components, will be necessary.	Failing to undertake adequate measures to ensure the protection of mechanical system components.
Repairing mechanical systems by augmenting or upgrading system components (such as installing new pipes and ducts), rewiring, or adding new compressors or boilers.	Replacing a mechanical system when its components could be upgraded and retained.
Replacing in kind or with a compatible substitute material those extensively deteriorated or missing visible features of mechanical systems when there are surviving prototypes, such as ceiling fans, radiators, grilles, or plumbing fixtures.	Installing a visible replacement feature of a mechanical system, if it is important in defining the historic character of the building, that does not convey the same appearance.

MECHANICAL SYSTEMS: HEATING, AIR CONDITIONING, ELECTRICAL, AND PLUMBING

RECOMMENDED	NOT RECOMMENDED
<i>The following work is highlighted to indicate that it is specific to Rehabilitation projects and should only be considered after the preservation concerns have been addressed.</i>	
Alterations and Additions for a New Use	
Installing a new mechanical system, if required, so that it results in the least alteration possible to the historic building and its character-defining features.	Installing a new mechanical system so that character-defining structural or interior features are radically changed, damaged, or destroyed.
Providing adequate structural support for the new mechanical equipment.	Failing to consider the weight and design of new mechanical equipment so that, as a result, historic structural members or finished surfaces are weakened or cracked.
Installing new mechanical and electrical systems and ducts, pipes, and cables in closets, service areas, and wall cavities to preserve the historic character of the interior space.	Installing systems and ducts, pipes, and cables in walls or ceilings in a manner that results in extensive loss or damage or otherwise obscures historic building materials and character-defining features.
Concealing HVAC ductwork in finished interior spaces, when possible, by installing it in secondary spaces (such as closets, attics, basements, or crawl spaces) or in appropriately-located, furred-down soffits.	Leaving HVAC ductwork exposed in most finished spaces or installing soffits in a location that will negatively impact the historic character of the interior or exterior of the building.
Installing exposed ductwork in a finished space when necessary to protect and preserve decorative or other features (such as column capitals, pressed-metal or ornamental plaster ceilings, coffers, or beams) that is painted, and appropriately located so that it will have minimal impact on the historic character of the space.	Installing exposed ductwork in a finished space when necessary to protect and preserve decorative or other features that is not painted, or is located where it will negatively impact the historic character of the space.
Lowering ceilings, installing a dropped ceiling, or constructing soffits to conceal ductwork in a finished space when this will not result in extensive loss or damage to historic materials or decorative and other features, and will not change the overall character of the space or the exterior appearance of the building (i.e., lowered ceilings or soffits visible through window glazing).	Lowering ceilings, installing a dropped ceiling, or constructing soffits to conceal ductwork in a finished space in a manner that results in extensive loss or damage to historic materials or decorative and other features, and will change the overall character of the space or the exterior appearance of the building.

MECHANICAL SYSTEMS: HEATING, AIR CONDITIONING, ELECTRICAL, AND PLUMBING

RECOMMENDED	NOT RECOMMENDED
Installing appropriately located, exposed ductwork in historically-unfinished interior spaces in industrial or utilitarian buildings.	
Installing a split system mechanical unit in a manner that will have minimal impact on the historic character of the interior and result in minimal loss of historic building material.	Installing a split system mechanical unit without considering its impact on the historic character of the interior or the potential loss of historic building material.
Installing heating or air conditioning window units only when the installation of any other system would result in significant damage or loss of historic materials or features.	
Installing mechanical equipment on the roof, when necessary, so that it is minimally visible to preserve the building's historic character and setting.	Installing mechanical equipment on the roof that is overly large or highly visible and negatively impacts the historic character of the building or setting.
Placing air conditioning compressors in a location on a secondary elevation of the historic building that is not highly visible.	Placing air conditioning compressors where they are highly visible and negatively impact the historic character of the building or setting.

[34] The new ceiling ducts installed during the conversion of this historic office building into apartments are minimal in design and discretely placed above the windows.



INTERIOR SPACES, FEATURES, AND FINISHES

RECOMMENDED	NOT RECOMMENDED
<p><i>Identifying, retaining, and preserving</i> a floor plan or interior spaces, features, and finishes that are important in defining the overall historic character of the building. Significant spatial characteristics include the size, configuration, proportion, and relationship of rooms and corridors; the relationship of features to spaces; and the spaces themselves, such as lobbies, lodge halls, entrance halls, parlors, theaters, auditoriums, gymnasiums, and industrial and commercial interiors. Color, texture, and pattern are important characteristics of features and finishes, which can include such elements as columns, plaster walls and ceilings, flooring, trim, fireplaces and mantels, paneling, light fixtures, hardware, decorative radiators, ornamental grilles and registers, windows, doors, and transoms; plaster, paint, wallpaper and wall coverings, and special finishes, such as marbling and graining; and utilitarian (painted or unpainted) features, including wood, metal, or concrete exposed columns, beams, and trusses and exposed load-bearing brick, concrete, and wood walls.</p>	<p>Altering a floor plan, or interior spaces (including individual rooms), features, and finishes, which are important in defining the overall historic character of the building so that, as a result, the character is diminished.</p> <p>Altering the floor plan by demolishing principal walls and partitions for a new use.</p> <p>Altering or destroying significant interior spaces by inserting additional floors or lofts; cutting through floors to create lightwells, light courts, or atriums; lowering ceilings; or adding new walls or removing historic walls.</p> <p>Relocating an interior feature, such as a staircase, so that the circulation pattern and the historic relationship between features and spaces are altered.</p> <p>Installing new material that obscures or damages character-defining interior features or finishes.</p> <p>Removing paint, plaster, or other finishes from historically-finished interior surfaces to create a new appearance (e.g., removing plaster to expose brick walls or a brick chimney breast, stripping paint from wood to stain or varnish it, or removing a plaster ceiling to expose unfinished beams).</p> <p>Applying paint, plaster, or other coatings to surfaces that have been unfinished historically, thereby changing their character.</p> <p>Changing the type of finish or its color, such as painting a historically-varnished wood feature, or removing paint from a historically-painted feature.</p>

INTERIOR SPACES, FEATURES, AND FINISHES

RECOMMENDED	NOT RECOMMENDED
Retaining decorative or other character-defining features or finishes that typify the showroom or interior of a historic store, such as a pressed-metal ceiling, a beaded-board ceiling, or wainscoting.	Removing decorative or other character-defining features or finishes that typify the showroom or interior of a historic store, such as a pressed-metal ceiling, a beaded-board ceiling, or wainscoting.
Protecting and maintaining historic materials (including plaster, masonry, wood, and metals) which comprise interior spaces through appropriate surface treatments, such as cleaning, paint removal, and reapplication of protective coating systems.	Failing to protect and maintain interior materials and finishes on a cyclical basis so that deterioration of interior features results.
Protecting interior features and finishes against arson and vandalism before project work begins by erecting temporary fencing or by covering broken windows and open doorways, while ensuring adequate ventilation, and by installing alarm systems keyed into local protection agencies.	Leaving the building unprotected and subject to vandalism before work begins, thereby allowing the interior to be damaged if it can be accessed through unprotected entrances.
Protecting interior features (such as a staircase, mantel, flooring, or decorative finishes) from damage during project work by covering them with plywood, heavy canvas, or plastic sheeting.	Failing to protect interior features and finishes when working on the interior.

[35] (a) Although deteriorated, the historic school corridor, shown on the left, with its character-defining features, including doors and transoms, was retained and repaired as part of the rehabilitation project (b).



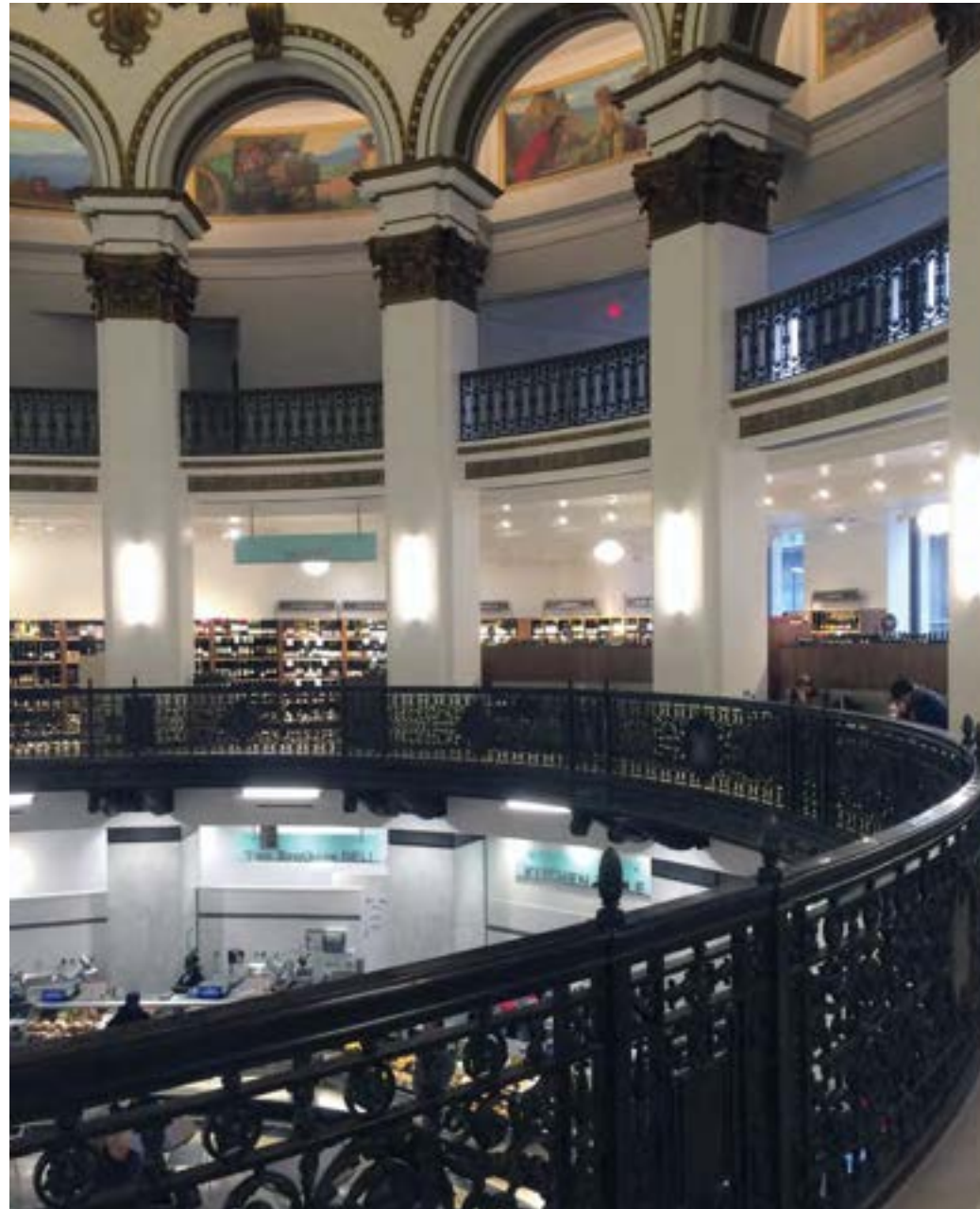

[36] The elaborate features and finishes of this historic banking hall in the Union Trust Company Building, in Cleveland, OH, were retained and repaired as part of its conversion into a food market.

INTERIOR SPACES, FEATURES, AND FINISHES

RECOMMENDED	NOT RECOMMENDED
Removing damaged or deteriorated paint and finishes only to the next sound layer using the gentlest method possible prior to repainting or refinishing using compatible paint or other coating systems.	Using potentially damaging methods, such as open-flame torches or abrasive techniques, to remove paint or other coatings. Removing paint that is firmly adhered to interior surfaces.
Using abrasive cleaning methods only on the interior of industrial or warehouse buildings with utilitarian, unplastered masonry walls and where wood features are not finished, molded, beaded, or worked by hand. Low-pressure abrasive cleaning (e.g., sand-blasting or other media blasting) should only be considered if test patches show no surface damage and after gentler methods have proven ineffective.	Using abrasive methods anywhere but utilitarian and industrial interior spaces or when there are other methods that are less likely to damage the surface of the material.
Evaluating the overall condition of the interior materials, features, and finishes to determine whether more than protection and maintenance, such as repairs to features and finishes, will be necessary.	Failing to undertake adequate measures to ensure the protection of interior materials, features, and finishes.
Repairing interior features and finishes by patching, splicing, consolidating, or otherwise reinforcing the materials using recognized preservation methods. Repairs may include the limited replacement in kind or with a compatible substitute material of those extensively deteriorated or missing parts of interior features when there are surviving prototypes, such as stairs, balustrades, wood paneling, columns, decorative wall finishes, and ornamental pressed-metal or plaster ceilings. Repairs should be physically and visually compatible.	Removing materials that could be repaired or using improper repair techniques. Replacing an entire interior feature (such as a staircase, mantel, or door surround) or a finish (such as a plaster) when repair of materials and limited replacement of deteriorated or missing components are feasible.



[37] Exposed and painted ducts were appropriately installed here in a retail space in Denver's historic Union Station after considering other options that would have impacted the ceiling height, or damaged or obscured the ornamental plaster crown molding. *Photo: Heritage Consulting Group.*

[38] The rehabilitation project retained the industrial character of this historic factory building, which included installation of a fire-rated, clear glass enclosure that allows the stairway, an important interior feature, to remain visible.



[39] Leaving the ceiling structure exposed and installing exposed ductwork where it does not impact the windows, are appropriate treatments when rehabilitating an industrial building for another use.

INTERIOR SPACES, FEATURES, AND FINISHES

RECOMMENDED

NOT RECOMMENDED

Replacing in kind an entire interior feature that is too deteriorated to repair (if the overall form and detailing are still evident) using the physical evidence as a model to reproduce the feature. Examples could include wainscoting, window and door surrounds, or stairs. If using the same kind of material is not feasible, then a compatible substitute material may be considered.

Removing a character-defining interior feature that is unrepairable and not replacing it, or replacing it with a new feature or finish that does not match the historic feature.

Using a substitute material for the replacement that does not convey the same appearance of the interior feature or that is physically incompatible.

Using a substitute material for the replacement that does not convey the same appearance of the interior feature or that is physically incompatible.

The following work is highlighted to indicate that it is specific to Rehabilitation projects and should only be considered after the preservation concerns have been addressed.

Designing the Replacement for Missing Historic Features

Designing and installing a new interior feature or finish when the historic feature or finish is completely missing. This could include missing walls, stairs, mantels, wood trim, and plaster, or even entire rooms if the historic spaces, features, and finishes are missing or have been destroyed by inappropriate alterations. The design may be an accurate restoration based on documentary and physical evidence, but only when the feature or finish to be replaced coexisted with the features currently in the building. Or, it may be a new design that is compatible with the size, scale, material, and color of the historic building.

Creating an inaccurate appearance because the replacement for the missing feature is based upon insufficient physical or historic documentation; is not a compatible design; or because the feature did not coexist with the feature currently on the building.

Introducing a new interior feature or finish that is incompatible in size, scale, material, color, and finish.

Alterations and Additions for a New Use

Installing new or additional systems required for a new use for the building, such as bathrooms and mechanical equipment, in secondary spaces to preserve the historic character of the most significant interior spaces.

Subdividing primary spaces, lowering ceilings, or damaging or obscuring character-defining features (such as fireplaces, windows, or stairways) to accommodate a new use for the building.

INTERIOR SPACES, FEATURES, AND FINISHES

RECOMMENDED	NOT RECOMMENDED
Installing new mechanical and electrical systems and ducts, pipes, and cables in closets, service areas, and wall cavities to preserve the historic character of interior spaces, features, and finishes.	Installing ducts, pipes, and cables where they will obscure character-defining features or negatively impact the historic character of the interior.
Creating open work areas, when required by the new use, by selectively removing walls only in secondary spaces, less significant upper floors, or other less-visible locations to preserve primary public spaces and circulation systems.	
Retaining the configuration of corridors, particularly in buildings with multiple floors with repetitive plans (such as office and apartment buildings or hotels), where not only the floor plan is character defining, but also the width and the length of the corridor, doorways, transoms, trim, and other features, such as wainscoting and glazing.	Making extensive changes to the character of significant historic corridors by narrowing or radically shortening them, or removing their character-defining features.
Reusing decorative material or features that had to be removed as part of the rehabilitation work (including baseboards, door casing, paneled doors, and wainscoting) and reusing them in areas where these features are missing or are too deteriorated to repair.	Discarding historic material when it can be reused to replace missing or damaged features elsewhere in the building, or reusing material in a manner that may convey a false sense of history.
Installing permanent partitions in secondary, rather than primary, spaces whenever feasible. Removable partitions or partial-height walls that do not destroy the sense of space often may be installed in large character-defining spaces when required by a new use.	Installing partitions that abut windows and glazing or that damage or obscure character-defining spaces, features, or finishes.
Enclosing a character-defining interior stairway, when required by code, with fire-rated glass walls or large, hold-open doors so that the stairway remains visible and its historic character is retained.	Enclosing a character-defining interior stairway for safety or functional reasons in a manner that conceals it or destroys its character.
Locating new, code-required stairways or elevators in secondary and service areas of the historic building.	Making incompatible changes or damaging or destroying character-defining spaces, features, or finishes when adding new code-required stairways and elevators.



[41] Not Recommended: Leaving fragments of deteriorated or “sculpted” plaster is not a compatible treatment for either finished or unfinished interior spaces.

[40] Not Recommended: Removing a finished ceiling and leaving the structure exposed in a historic retail space does not meet the Standards for Rehabilitation.



INTERIOR SPACES, FEATURES, AND FINISHES

RECOMMENDED	NOT RECOMMENDED
Creating an atrium, light court, or lightwell to provide natural light when required for a new use only when it can be done in a manner that preserves significant interior spaces, features, and finishes or important exterior elevations.	Destroying or damaging character-defining interior spaces, features, or finishes, or damaging the structural system to create an atrium, light court, or lightwell.
Inserting a new floor, mezzanine, or loft when required for a new use if it does not damage or destroy significant interior features and finishes and is not visible from the exterior of the building.	Inserting a new floor, mezzanine, or loft that damages or destroys significant interior features or abuts window glazing and is visible from the exterior of the building, and, thus, negatively impacts its historic character.
Inserting a new floor, when necessary for a new use, only in large assembly spaces that are secondary to another assembly space in the building; in a space that has been greatly altered; or where character-defining features have been lost or are too deteriorated to repair.	Inserting a new floor in significant, large assembly spaces with distinctive features and finishes, which negatively impacts their historic character.
Installing exposed ductwork in a finished space when necessary to protect and preserve decorative or other features (such as column capitals, ornamental plaster or pressed-metal ceilings, coffers, or beams) that is designed, painted, and appropriately located so that it will have minimal impact on the historic character of the space.	Installing exposed ductwork in a finished space when necessary to protect and preserve decorative or other features that is not painted, or is located where it will negatively impact the historic character of the space.
Lowering ceilings, installing a dropped ceiling, or constructing soffits to conceal ductwork in a finished space when they will not result in extensive loss or damage to historic materials or decorative and other features, and will not change the overall character of the space or the exterior appearance of the building (i.e., lowered ceilings or soffits visible through window glazing).	Lowering ceilings, installing a dropped ceiling, or constructing soffits to conceal ductwork in a finished space in a manner that results in extensive loss or damage to historic materials or decorative and other features, and will change the overall character of the space or the exterior appearance of the building.
Installing a split system mechanical unit in a manner that will have minimal impact on the historic character of the interior and will result in minimal loss of historic building material.	Installing a split system mechanical unit without considering its impact on the historic character of the interior or the potential loss of historic building material.

BUILDING SITE

RECOMMENDED

Identifying, retaining, and preserving features of the building site that are important in defining its overall historic character. Site features may include walls, fences, or steps; circulation systems, such as walks, paths or roads; vegetation, such as trees, shrubs, grass, orchards, hedges, windbreaks, or gardens; landforms, such as hills, terracing, or berms; furnishings and fixtures, such as light posts or benches; decorative elements, such as sculpture, statuary, or monuments; water features, including fountains, streams, pools, lakes, or irrigation ditches; and subsurface archeological resources, other cultural or religious features, or burial grounds which are also important to the site.

NOT RECOMMENDED

Removing or substantially changing buildings and their features or site features which are important in defining the overall historic character of the property so that, as a result, the character is diminished.



[42] This garden is an important character-defining landscape feature on this college campus.

BUILDING SITE

RECOMMENDED	NOT RECOMMENDED
Retaining the historic relationship between buildings and the landscape.	<p>Removing or relocating buildings or landscape features, thereby destroying the historic relationship between buildings and the landscape.</p> <p>Removing or relocating buildings on a site or in a complex of related historic structures (such as a mill complex or farm), thereby diminishing the historic character of the site or complex.</p> <p>Moving buildings onto the site, thereby creating an inaccurate historic appearance.</p> <p>Changing the grade level of the site if it diminishes its historic character. For example, lowering the grade adjacent to a building to maximize use of a basement, which would change the historic appearance of the building and its relation to the site.</p>
<i>Protecting and maintaining</i> buildings and site features by providing proper drainage to ensure that water does not erode foundation walls, drain toward the building, or damage or erode the landscape.	Failing to ensure that site drainage is adequate so that buildings and site features are damaged or destroyed; or, alternatively, changing the site grading so that water does not drain properly.
Correcting any existing irrigation that may be wetting the building excessively.	Neglecting to correct any existing irrigation that may be wetting the building excessively.
Minimizing disturbance of the terrain around buildings or elsewhere on the site, thereby reducing the possibility of destroying or damaging important landscape features, archeological resources, other cultural or religious features, or burial grounds.	Using heavy machinery or equipment in areas where it may disturb or damage important landscape features, archeological resources, other cultural or religious features, or burial grounds.
Surveying and documenting areas where the terrain will be altered to determine the potential impact to important landscape features, archeological resources, other cultural or religious features, or burial grounds.	Failing to survey the building site prior to beginning work, which may result in damage or loss of important landscape features, archeological resources, other cultural or religious features, or burial grounds.

BUILDING SITE

RECOMMENDED	NOT RECOMMENDED
Protecting (e.g., preserving in place) important site features, archeological resources, other cultural or religious features, or burial grounds.	Leaving known site features or archeological material unprotected so that it is damaged during rehabilitation work.
Planning and carrying out any necessary investigation before rehabilitation begins, using professional archeologists and methods, when preservation in place is not feasible.	Allowing unqualified personnel to perform data recovery on archeological resources, which can result in damage or loss of important archeological material
Preserving important landscape features through regularly-scheduled maintenance of historic plant material.	Allowing important landscape features or archeological resources to be lost, damaged, or to deteriorate due to inadequate protection or lack of maintenance
Protecting the building site and landscape features against arson and vandalism before rehabilitation work begins by erecting temporary fencing and by installing alarm systems keyed into local protection agencies.	Leaving the property unprotected and subject to vandalism before work begins so that the building site and landscape features, archeological resources, other cultural or religious features, or burial grounds can be damaged or destroyed. Removing or destroying features from the site, such as fencing, paths or walkways, masonry balustrades, or plant material.
Installing protective fencing, bollards, and stanchions on a building site, when necessary for security, that are as unobtrusive as possible.	Installing protective fencing, bollards, and stanchions on a building site, when necessary for security, without taking into consideration their location and visibility so that they negatively impact the historic character of the site.
Providing continued protection and maintenance of buildings and landscape features on the site through appropriate grounds and landscape management.	Failing to protect and maintain materials and features from the restoration period on a cyclical basis so that deterioration of the site results.
Protecting buildings and landscape features when working on the site.	Failing to protect building and landscape features during work on the site or failing to repair damaged or deteriorated site features.

BUILDING SITE

RECOMMENDED	NOT RECOMMENDED
Evaluating the overall condition of materials and features to determine whether more than protection and maintenance, such as repairs to site features, will be necessary.	Failing to undertake adequate measures to ensure the protection of the site.
Repairing historic site features which have been damaged, are deteriorated, or have missing components order reestablish the whole feature and to ensure retention of the integrity of the historic materials. Repairs may include limited replacement in kind or with a compatible substitute material of those extensively deteriorated or missing parts of site features when there are surviving prototypes, such as paving, railings, or individual plants within a group (e.g., a hedge). Repairs should be physically and visually compatible.	<p>Removing materials and features that could be repaired or using improper repair techniques.</p> <p>Replacing an entire feature of the site (such as a fence, walkway, or drive) when repair of materials and limited replacement of deteriorated or missing components are feasible.</p>



[43] The industrial character of the site was retained when this brewery complex was rehabilitated for residential use.



[44] **Not Recommended:** (a-b) The historic character of this plantation house (marked in blue on plan on opposite page) and its site was diminished and adversely impacted when multiple new buildings like this (#3 on plan) were constructed on the property (c).

BUILDING SITE

RECOMMENDED

Replacing in kind an entire feature of the site that is too deteriorated to repair (if the overall form and detailing are still evident) using the physical evidence as a model to reproduce the feature. Examples could include a walkway or a fountain, a land form, or plant material. If using the same kind of material is not feasible, then a compatible substitute material may be considered.

NOT RECOMMENDED

Removing a character-defining feature of the site that is unrepairable and not replacing it, or replacing it with a new feature that does not match.

Using a substitute material for the replacement that does not convey the same appearance of the surviving site feature or that is physically or ecologically incompatible.

Adding conjectural landscape features to the site (such as period reproduction light fixtures, fences, fountains, or vegetation) that are historically inappropriate, thereby creating an inaccurate appearance of the site.



BUILDING SITE

RECOMMENDED

NOT RECOMMENDED

The following work is highlighted to indicate that it is specific to Rehabilitation projects and should only be considered after the preservation concerns have been addressed.

Designing the Replacement for Missing Historic Features

Designing and installing a new feature on a site when the historic feature is completely missing. This could include missing outbuildings, terraces, drives, foundation plantings, specimen trees, and gardens. The design may be an accurate restoration based on documentary and physical evidence, but only when the feature to be replaced coexisted with the features currently on the site. Or, it may be a new design that is compatible with the historic character of the building and site.

Creating an inaccurate appearance because the replacement for the missing feature is based upon insufficient physical or historic documentation, is not a compatible design, or because the feature did not coexist with the features currently on the site.

Introducing a new feature, including plant material, that is visually incompatible with the site or that alters or destroys the historic site patterns or use.

Alterations and Additions for a New Use

Designing new onsite features (such as parking areas, access ramps, or lighting), when required by a new use, so that they are as unobtrusive as possible, retain the historic relationship between the building or buildings and the landscape, and are compatible with the historic character of the property.

Locating parking areas directly adjacent to historic buildings where vehicles may cause damage to buildings or landscape features or when they negatively impact the historic character of the building site if landscape features and plant materials are removed.

Designing new exterior additions to historic buildings or adjacent new construction that are compatible with the historic character of the site and preserves the historic relationship between the building or buildings and the landscape.

Introducing new construction on the building site which is visually incompatible in terms of size, scale, design, material, or color, which destroys historic relationships on the site, or which damages or destroys important landscape features, such as replacing a lawn with paved parking areas or removing mature trees to widen a driveway.

Removing non-significant buildings, additions, or site features which detract from the historic character of the site.

Removing a historic building in a complex of buildings or removing a building feature or a landscape feature which is important in defining the historic character of the site.

Locating an irrigation system needed for a new or continuing use of the site where it will not cause damage to historic buildings.

Locating an irrigation system needed for a new or continuing use of the site where it will damage historic buildings.



[45] Undertaking a survey to document archeological resources may be considered in some rehabilitation projects when a new exterior addition is planned.

SETTING (DISTRICT / NEIGHBORHOOD)

RECOMMENDED

Identifying, retaining, and preserving building and landscape features that are important in defining the overall historic character of the setting. Such features can include circulation systems, such as roads and streets; furnishings and fixtures, such as light posts or benches; vegetation, gardens and yards; adjacent open space, such as fields, parks, commons, or woodlands; and important views or visual relationships.

NOT RECOMMENDED

Removing or substantially changing those building and landscape features in the setting which are important in defining the historic character so that, as a result, the character is diminished.



[46] The varied size, shapes, and architectural styles of these historic buildings are unique to this street in Christiansted, St. Croix, USVI, and should be retained in a rehabilitation project.

[47] Original paving stones contribute to the character of the historic setting and distinguish this block from other streets in the district.



SETTING (DISTRICT / NEIGHBORHOOD)

RECOMMENDED

Retaining the historic relationship between buildings and landscape features in the setting. For example, preserving the relationship between a town common or urban plaza and the adjacent houses, municipal buildings, roads, and landscape and streetscape features.

NOT RECOMMENDED

Altering the relationship between the buildings and landscape features in the setting by widening existing streets, changing landscape materials, or locating new streets or parking areas where they may negatively impact the historic character of the setting.

Removing or relocating buildings or landscape features, thereby destroying the historic relationship between buildings and the landscape in the setting.



[48] Old police and fire call boxes, which are distinctive features in this historic district, have been retained, and now showcase work by local artists.



[49] Low stone walls are character-defining features in this hilly, early-20th-century residential neighborhood.



SETTING (DISTRICT / NEIGHBORHOOD)

RECOMMENDED	NOT RECOMMENDED
<p>Protecting and maintaining historic features in the setting through regularly-scheduled maintenance and grounds and landscape management.</p>	<p>Failing to protect and maintain materials in the setting on a cyclical basis so that deterioration of buildings and landscape features results.</p> <p>Stripping or removing historic features from buildings or the setting, such as a porch, fencing, walkways, or plant material.</p>
<p>Installing protective fencing, bollards, and stanchions in the setting, when necessary for security, that are as unobtrusive as possible.</p>	<p>Installing protective fencing, bollards, and stanchions in the setting, when necessary for security, without taking into consideration their location and visibility so that they negatively impact the historic character of the setting.</p>
<p>Protecting buildings and landscape features when undertaking work in the setting.</p>	<p>Failing to protect buildings and landscape features during work in the setting.</p>
<p>Evaluating the overall condition of materials and features to determine whether more than protection and maintenance, such as repairs to materials and features in the setting, will be necessary.</p>	<p>Failing to undertake adequate measures to ensure the protection of materials and features in the setting.</p>
<p>Repairing features in the setting by reinforcing the historic materials. Repairs may include the replacement in kind or with a compatible substitute material of those extensively deteriorated or missing parts of setting features when there are surviving prototypes, such as fencing, paving materials, trees, and hedgerows. Repairs should be physically and visually compatible.</p>	<p>Failing to repair and reinforce damaged or deteriorated historic materials and features in the setting.</p> <p>Removing material that could be repaired or using improper repair techniques.</p> <p>Replacing an entire feature of the building or landscape in the setting when repair of materials and limited replacement of deteriorated or missing components are feasible.</p>

SETTING (DISTRICT / NEIGHBORHOOD)

RECOMMENDED	NOT RECOMMENDED
<p>Replacing in kind an entire building or landscape feature in the setting that is too deteriorated to repair (if the overall form and detailing are still evident) using the physical evidence as a model to reproduce the feature. If using the same kind of material is not feasible, then a compatible substitute material may be considered.</p>	<p>Removing a character-defining feature of the building or landscape from the setting that is unrepairable and not replacing it or replacing it with a new feature that does not match.</p> <p>Using a substitute material for the replacement that does not convey the same appearance of the surviving building or landscape feature in the setting or that is physically or ecologically incompatible.</p>
<p><i>The following work is highlighted to indicate that it is specific to Rehabilitation projects and should only be considered after the preservation concerns have been addressed.</i></p>	
<p>Designing the Replacement for Missing Historic Features</p>	
<p>Designing and installing a new feature of the building or landscape in the setting when the historic feature is completely missing. This could include missing steps, streetlights, terraces, trees, and fences. The design may be an accurate restoration based on documentary and physical evidence, but only when the feature to be replaced coexisted with the features currently in the setting. Or, it may be a new design that is compatible with the historic character of the setting.</p>	<p>Creating an inaccurate appearance because the replacement for the missing feature is based upon insufficient physical or historic documentation; is not a compatible design, or because the feature did not coexist with the features currently in the setting.</p> <p>Introducing a new building or landscape feature that is visually or otherwise incompatible with the setting's historic character (e.g., replacing low metal fencing with a high wood fence).</p>
<p>Alterations and Additions for a New Use</p>	
<p>Designing new features (such as parking areas, access ramps, or lighting), when required by a new use, so that they are as unobtrusive as possible, retain the historic relationships between buildings and the landscape in the setting, and are compatible with the historic character of the setting.</p>	<p>Locating parking areas directly adjacent to historic buildings where vehicles may cause damage to buildings or landscape features or when they negatively impact the historic character of the setting if landscape features and plant materials are removed.</p>
<p>Designing new exterior additions to historic buildings or adjacent new construction that are compatible with the historic character of the setting that preserve the historic relationship between the buildings and the landscape.</p>	<p>Introducing new construction into historic districts which is visually incompatible or that destroys historic relationships within the setting, or which damages or destroys important landscape features.</p>
<p>Removing non-significant buildings, additions, or landscape features which detract from the historic character of the setting.</p>	<p>Removing a historic building, a building feature, or landscape feature which is important in defining the historic character of the setting.</p>

CODE-REQUIRED WORK

RECOMMENDED

NOT RECOMMENDED

*Sensitive solutions to meeting accessibility and life-safety code requirements are an important part of protecting the historic character of the building and site. Thus, work that must be done to meet use-specific code requirements should be considered early in planning a **Rehabilitation** of a historic building for a new use. Because code mandates are directly related to occupancy, some uses require less change than others and, thus, may be more appropriate for a historic building. Early coordination with code enforcement authorities can reduce the impact of alterations necessary to comply with current codes.*

ACCESSIBILITY

Identifying the historic building’s character-defining exterior features, interior spaces, features, and finishes, and features of the site and setting which may be affected by accessibility code-required work.

Undertaking accessibility code-required alterations before identifying those exterior features, interior spaces, features, and finishes, and features of the site and setting which are character defining and, therefore, must be preserved.

Complying with barrier-free access requirements in such a manner that the historic building’s character-defining exterior features, interior spaces, features, and finishes, and features of the site and setting are preserved or impacted as little as possible.

Altering, damaging, or destroying character-defining exterior features, interior spaces, features, and finishes, or features of the site and setting while making modifications to a building, its site, or setting to comply with accessibility requirements.

[50] This kitchen in a historic apartment complex was rehabilitated to meet accessibility requirements.

[51] A new interior access ramp with a simple metal railing is compatible with the character of this mid-century-modern building.

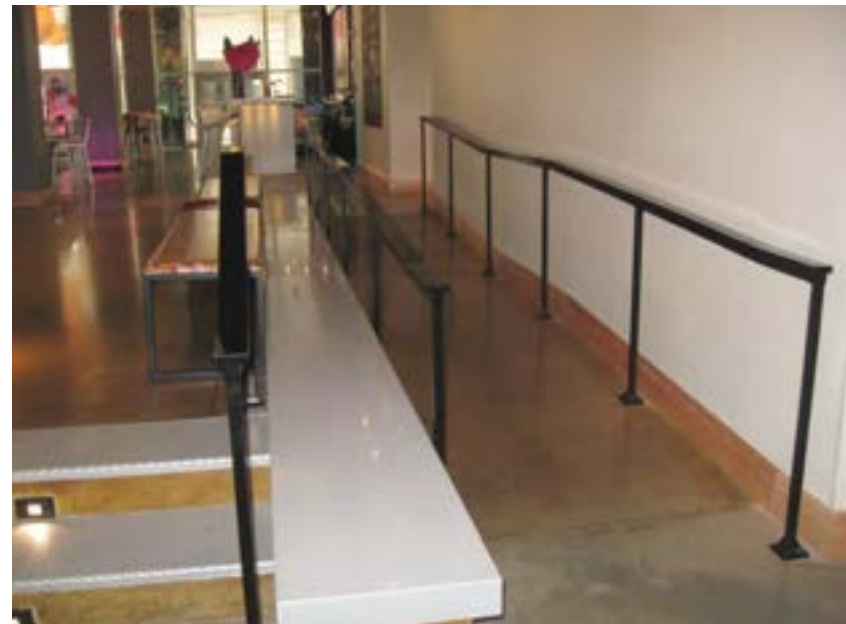

CODE-REQUIRED WORK

RECOMMENDED	NOT RECOMMENDED
Working with specialists in accessibility and historic preservation to determine the most sensitive solutions to comply with access requirements in a historic building, its site, or setting.	Making changes to historic buildings, their sites, or setting without first consulting with specialists in accessibility and historic preservation to determine the most appropriate solutions to comply with accessibility requirements.
Providing barrier-free access that promotes independence for the user while preserving significant historic features.	Making modifications for accessibility that do not provide independent, safe access while preserving historic features.
Finding solutions to meet accessibility requirements that minimize the impact of any necessary alteration on the historic building, its site, and setting, such as compatible ramps, paths, and lifts.	Making modifications for accessibility without considering the impact on the historic building, its site, and setting.

[52] The access ramp blends in with the stone façade of the First National Bank in Stephenville, TX, and is appropriately located on the side where it is does not impact the historic character of the building. Photo: Nancy McCoy, QuimbyMcCoy Preservation Architecture, LLP.



[53] This entrance ramp (right) is compatible with the historic character of this commercial building.



[54] The gently-sloped path in a historic park in Kansas City, MO, which accesses the memorial below, includes a rest area part way up the hill. Photo: STRATA Architecture + Preservation.

CODE-REQUIRED WORK

RECOMMENDED	NOT RECOMMENDED
Using relevant sections of existing codes regarding accessibility for historic buildings that provide alternative means of code compliance when code-required work would otherwise negatively impact the historic character of the property.	
Minimizing the impact of accessibility ramps by installing them on secondary elevations when it does not compromise accessibility or by screening them with plantings.	Installing elevators, lifts, or incompatible ramps at a primary entrance, or relocating primary entrances to secondary locations to provide access without investigating other options or locations.
Adding a gradual slope or grade to the sidewalk, if appropriate, to access the entrance rather than installing a ramp that would be more intrusive to the historic character of the building and the district.	
Adding an exterior stair or elevator tower that is compatible with the historic character of the building in a minimally-visible location only when it is not possible to accommodate it on the interior without resulting in the loss of significant historic spaces, features, or finishes.	
Installing a lift as inconspicuously as possible when it is necessary to locate it on a primary elevation of the historic building.	
Installing lifts or elevators on the interior in secondary or less significant spaces where feasible.	Installing lifts or elevators on the interior in primary spaces which will negatively impact the historic character of the space.



[55] The lift is compatible with the industrial character of this former warehouse.

CODE-REQUIRED WORK

RECOMMENDED

NOT RECOMMENDED

LIFE SAFETY

Identifying the historic building's character-defining exterior features, interior spaces, features, and finishes, and features of the site and setting which may be affected by life-safety code-required work.
Complying with life-safety codes (including requirements for impact-resistant glazing, security, and seismic retrofit) in such a manner that the historic building's character-defining exterior features, interior spaces, features, and finishes, and features of the site and setting are preserved or impacted as little as possible.
Removing building materials only after testing has been conducted to identify hazardous materials, and using only the least damaging abatement methods.
Providing workers with appropriate personal equipment for protection from hazards on the worksite.
Working with code officials and historic preservation specialists to investigate systems, methods, or devices to make the building compliant with life-safety codes to ensure that necessary alterations will be compatible with the historic character of the building.
Using relevant sections of existing codes regarding life safety for historic buildings that provide alternative means of code compliance when code-required work would otherwise negatively impact the historic character of the building.

Undertaking life-safety code-required alterations before identifying those exterior features, interior spaces, features, and finishes, and features of the site and setting which are character defining and, therefore, must be preserved.
Altering, damaging, or destroying character-defining exterior features, interior spaces, features, and finishes, or features of the site and setting while making modifications to a building, its site, or setting to comply with life-safety code requirements.
Removing building materials without testing first to identify the hazardous materials, or using potentially damaging methods of abatement.
Removing hazardous or toxic materials without regard for workers' health and safety or environmentally-sensitive disposal of the materials.
Making life-safety code-required changes to the building without consulting code officials and historic preservation specialists, with the result that alterations negatively impact the historic character of the building.



[56 a-b] In order to continue in its historic use, the door openings of this 1916 Colonial Revival-style fire station had to be widened to accommodate the larger size of modern fire trucks. Although this resulted in some change to the arched door surrounds, it is minimal and does not negatively impact the historic character of the building. (a) Above, before; Photo: Fire and Emergency Medical Services Department (FEMS), Washington, D.C.; below, after.



[57] Workers wear protective clothing while removing lead paint from metal features.



[59] (a-b) The decorative concrete balcony railings on this 1960s building did not meet life-safety code requirements. They were replaced with new glass railings with a fritted glass pattern matching the original design—a creative solution that satisfies codes, while preserving the historic appearance of the building when viewed from the street (c-d). Photos: (a, b, d) ERA Architects, Inc.; (c) Nathan Cyprys, photographer.

CODE-REQUIRED WORK

RECOMMENDED	NOT RECOMMENDED
Upgrading historic stairways and elevators to meet life-safety codes so that they are not damaged or otherwise negatively impacted.	Damaging or making inappropriate alterations to historic stairways and elevators or to adjacent features, spaces, or finishes in the process of doing work to meet code requirements.
Installing sensitively-designed fire-suppression systems, such as sprinklers, so that historic features and finishes are preserved.	Covering character-defining wood features with fire-retardant sheathing, which results in altering their appearance.
Applying fire-retardant coatings when appropriate, such as intumescent paint, to protect steel structural systems.	Using fire-retardant coatings if they will damage or obscure character-defining features.
Adding a new stairway or elevator to meet life-safety code requirements in a manner that preserves adjacent character-defining features and spaces.	Altering, damaging, or destroying character-defining spaces, features, or finishes when adding a new code-required stairway or elevator.
Using existing openings on secondary or less-visible elevations or, if necessary, creating new openings on secondary or less-visible elevations to accommodate second egress requirements.	Using a primary or other highly-visible elevation to accommodate second egress requirements without investigating other options or locations.
Placing a code-required stairway or elevator that cannot be accommodated within the historic building in a new exterior addition located on a secondary or minimally-visible elevation.	Constructing a new addition to accommodate code-required stairs or an elevator on character-defining elevations or where it will obscure, damage, or destroy character-defining features of the building, its site, or setting.
Designing a new exterior stairway or elevator tower addition that is compatible with the historic character of the building.	



[58] Fire doors that retract into the walls have been installed here (not visible in photo) preserve the historic character of this corridor.

RESILIENCE TO NATURAL HAZARDS

RECOMMENDED

NOT RECOMMENDED

Resilience to natural hazards should be addressed as part of the treatment Rehabilitation. A historic building may have existing characteristics or features that help address or minimize the impacts of natural hazards. These should be used to best advantage and should be taken into consideration early in the planning stages of a rehabilitation project before proposing any new treatments. When new adaptive treatments are needed they should be carried out in a manner that will have the least impact on the historic character of the building, its site, and setting. .

Identifying the vulnerabilities of the historic property to the impacts of natural hazards (such as wildfires, hurricanes, or tornadoes) using the most current climate information and data available.	Failing to identify and periodically reevaluate the potential vulnerability of the building, its site, and setting to the impacts of natural hazards.
Assessing the potential impacts of known vulnerabilities on character-defining features of the building, its site, and setting; and reevaluating and reassessing potential impacts on a regular basis.	
Documenting the property and character-defining features as a record and guide for future repair work, should it be necessary, and storing the documentation in a weatherproof location.	Failing to document the historic property and its character-defining features with the result that such information is not available in the future to guide repair or reconstruction work, should it be necessary.
Ensuring that historic resources inventories and maps are accurate, up to date, and accessible in times of emergency.	
Maintaining the building, its site, and setting in good repair, and regularly monitoring character-defining features.	Failing to regularly monitor and maintain the property and the building systems in good repair.
Using and maintaining existing characteristics and features of the historic building, its site, setting, and larger environment (such as shutters for storm protection or a site wall that keeps out flood waters) that may help to avoid or minimize the impacts of natural hazards	Allowing loss, damage, or destruction to occur to the historic building, its site, or setting by failing to evaluate potential future impacts of natural hazards or to plan and implement adaptive measures, if necessary to address possible threats.
Undertaking work to prevent or minimize the loss, damage, or destruction of the historic property while retaining and preserving significant features and the overall historic character of the building, its site, and setting.	Carrying out adaptive measures intended to address the impacts of natural hazards that are unnecessarily invasive or will otherwise adversely impact the historic character of the building, its site, or setting.



[60] In some instances, it may be necessary to elevate a historic building located in a floodplain to protect it. But this treatment is appropriate only if elevating the building will retain its historic character, including its relationship to the site, and its new height will be compatible with surrounding buildings if in a historic district. The house on the right, which has been raised only slightly, has retained its historic character. The house on the left has been raised several feet higher, resulting in a greater impact on the historic character of the house and the district.

RESILIENCE TO NATURAL HAZARDS

RECOMMENDED	NOT RECOMMENDED
Ensuring that, when planning work to adapt for natural hazards, all feasible alternatives are considered, and that the options requiring the least alteration are considered first.	
Implementing local and regional traditions (such as elevating residential buildings at risk of flooding or reducing flammable vegetation around structures in fire-prone areas) for adapting buildings and sites in response to specific natural hazards, when appropriate. Such traditional methods may be appropriate if they are compatible with the historic character of the building, its site, and setting.	Implementing a treatment traditionally used in another region or one typically used for a different property type or architectural style which is not compatible with the historic character of the property.
Using special exemptions and variances when adaptive treatments to protect buildings from known hazards would otherwise negatively impact the historic character of the building, its site, and setting.	
Considering adaptive options, whenever possible, that would protect multiple historic resources, if the treatment can be implemented without negatively impacting the historic character of the district, or archeological resources, other cultural or religious features, or burial grounds.	

Sustainability

Sustainability is usually a very important and integral part of the treatment **Rehabilitation**. Existing energy-efficient features should be taken into consideration early in the planning stages of a rehabilitation project before proposing any energy improvements. There are numerous treatments that may be used to upgrade a historic building to help it operate more efficiently while retaining its character.

The topic of sustainability is addressed in detail in **The Secretary of the Interior's Standards for Rehabilitation & Illustrated Guidelines on Sustainability for Rehabilitating Historic Buildings**.

NEW EXTERIOR ADDITIONS TO HISTORIC BUILDINGS AND RELATED NEW CONSTRUCTION

RECOMMENDED	NOT RECOMMENDED
New Additions	
Placing functions and services required for a new use (including elevators and stairways) in secondary or non-character-defining interior spaces of the historic building rather than constructing a new addition.	Expanding the size of the historic building by constructing a new addition when requirements for the new use could be met by altering non-character-defining interior spaces.
Constructing a new addition on a secondary or non-character-defining elevation and limiting its size and scale in relationship to the historic building.	Constructing a new addition on or adjacent to a primary elevation of the building which negatively impacts the building's historic character.
Constructing a new addition that results in the least possible loss of historic materials so that character-defining features are not obscured, damaged, or destroyed.	Attaching a new addition in a manner that obscures, damages, or destroys character-defining features of the historic building.
Designing a new addition that is compatible with the historic building.	Designing a new addition that is significantly different and, thus, incompatible with the historic building.
Ensuring that the addition is subordinate and secondary to the historic building and is compatible in massing, scale, materials, relationship of solids to voids, and color.	Constructing a new addition that is as large as or larger than the historic building, which visually overwhelms it (i.e., results in the diminution or loss of its historic character).

NEW EXTERIOR ADDITIONS TO HISTORIC BUILDINGS AND RELATED NEW CONSTRUCTION

RECOMMENDED

NOT RECOMMENDED

Using the same forms, materials, and color range of the historic building in a manner that does not duplicate it, but distinguishes the addition from the original building.	Duplicating the exact form, material, style, and detailing of the historic building in a new addition so that the new work appears to be historic.
Basing the alignment, rhythm, and size of the window and door openings of the new addition on those of the historic building.	
Incorporating a simple, recessed, small-scale hyphen, or connection, to physically and visually separate the addition from the historic building.	
Distinguishing the addition from the original building by setting it back from the wall plane of the historic building.	

[61 a-b] The materials, design, and location at the back of the historic house are important factors in making this a compatible new addition. Photos: © Maxwell MacKenzie.



NEW EXTERIOR ADDITIONS TO HISTORIC BUILDINGS AND RELATED NEW CONSTRUCTION

RECOMMENDED	NOT RECOMMENDED
Ensuring that the addition is stylistically appropriate for the historic building type (e.g., whether it is residential or institutional).	
Considering the design for a new addition in terms of its relationship to the historic building as well as the historic district, neighborhood, and setting.	



[62] The stair tower at the rear of this commercial building is a compatible new addition.

NEW EXTERIOR ADDITIONS TO HISTORIC BUILDINGS AND RELATED NEW CONSTRUCTION

RECOMMENDED

NOT RECOMMENDED

Rooftop Additions

Designing a compatible rooftop addition for a multi-story building, when required for a new use, that is set back at least one full bay from the primary and other highly-visible elevations and that is inconspicuous when viewed from surrounding streets.

Constructing a rooftop addition that is highly visible, which negatively impacts the character of the historic building, its site, setting, or district.

[63] (a) A mockup should be erected to demonstrate the visibility of a proposed rooftop addition and its potential impact on the historic building. Based on review of this mockup (orange marker), it was determined that the rooftop addition would meet the Standards (b). The addition is unobtrusive and blends in with the building behind it.



NEW EXTERIOR ADDITIONS TO HISTORIC BUILDINGS AND RELATED NEW CONSTRUCTION

RECOMMENDED	NOT RECOMMENDED
<p>Limiting a rooftop addition to one story in height to minimize its visibility and its impact on the historic character of the building.</p>	<p>Constructing a highly-visible, multi-story rooftop addition that alters the building's historic character.</p> <p>Constructing a rooftop addition on low-rise, one- to three-story historic buildings that is highly visible, overwhelms the building, and negatively impacts the historic district.</p> <p>Constructing a rooftop addition with amenities (such as a raised pool deck with plantings, HVAC equipment, or screening) that is highly visible and negatively impacts the historic character of the building.</p>



[64] Not Recommended:
 It is generally not appropriate to construct a rooftop addition on a low-rise, two- to three-story building such as this, because it negatively affects its historic character.

NEW EXTERIOR ADDITIONS TO HISTORIC BUILDINGS AND RELATED NEW CONSTRUCTION

RECOMMENDED

NOT RECOMMENDED

Related New Construction

Adding a new building to a historic site or property only if the requirements for a new or continuing use cannot be accommodated within the existing structure or structures.

Adding a new building to a historic site or property when the project requirements could be accommodated within the existing structure or structures.

Locating new construction far enough away from the historic building, when possible, where it will be minimally visible and will not negatively affect the building's character, the site, or setting.

Placing new construction too close to the historic building so that it negatively impacts the building's character, the site, or setting.

[65] (a) This (far left) is a compatible new outbuilding constructed on the site of a historic plantation house (b). Although traditional in design, it is built of wood to differentiate it from the historic house (which is scored stucco) located at the back of the site so as not to impact the historic house, and minimally visible from the public right-of-way (c).



new addition

NEW EXTERIOR ADDITIONS TO HISTORIC BUILDINGS AND RELATED NEW CONSTRUCTION

RECOMMENDED	NOT RECOMMENDED
Designing new construction on a historic site or in a historic setting that it is compatible but differentiated from the historic building or buildings.	Replicating the features of the historic building when designing a new building, with the result that it may be confused as historic or original to the site or setting.
Considering the design for related new construction in terms of its relationship to the historic building as well as the historic district and setting.	
Ensuring that new construction is secondary to the historic building and does not detract from its significance.	<p>Adding new construction that results in the diminution or loss of the historic character of the building, including its design, materials, location, or setting.</p> <p>Constructing a new building on a historic property or on an adjacent site that is much larger than the historic building.</p> <p>Designing new buildings or groups of buildings to meet a new use that are not compatible in scale or design with the character of the historic building and the site, such as apartments on a historic school property that are too residential in appearance.</p>
Using site features or land formations, such as trees or sloping terrain, to help minimize the new construction and its impact on the historic building and property.	
Designing an addition to a historic building in a densely-built location (such as a downtown commercial district) to appear as a separate building or infill, rather than as an addition. In such a setting, the addition or the infill structure must be compatible with the size and scale of the historic building and surrounding buildings—usually the front elevation of the new building should be in the same plane (i.e., not set back from the historic building). This approach may also provide the opportunity for a larger addition or infill when the façade can be broken up into smaller elements that are consistent with the scale of the historic building and surrounding buildings.	



THE SECRETARY
OF THE INTERIOR'S
STANDARDS FOR
REHABILITATION &

ILLUSTRATED
GUIDELINES ON
SUSTAINABILITY
FOR
REHABILITATING
HISTORIC
BUILDINGS



U.S. Department of the Interior
National Park Service
Technical Preservation Services

THE SECRETARY OF THE INTERIOR'S STANDARDS FOR REHABILITATION &

ILLUSTRATED GUIDELINES ON SUSTAINABILITY FOR REHABILITATING HISTORIC BUILDINGS

Anne E. Grimmer with Jo Ellen Hensley | Liz Petrella | Audrey T. Tepper

U.S. Department of the Interior
National Park Service
Technical Preservation Services
Washington, D.C.

2011

Contents

iv	Acknowledgements
v	Foreword
vi	The Secretary of the Interior's Standards for Rehabilitation <i>Introduction to the Standards</i>
viii	Guidelines for Rehabilitating Historic Buildings <i>Introduction to the Guidelines</i>
xi	Guidelines on Sustainability for Rehabilitating Historic Buildings
1	Sustainability
2	<i>Planning</i>
3	<i>Maintenance</i>
4	<i>Windows</i>
8	<i>Weatherization and Insulation</i>
10	<i>Heating, Ventilating and Air Conditioning (HVAC) and Air Circulation</i>
14	<i>Solar Technology</i>
16	<i>Wind Power – Wind Turbines and Windmills</i>
18	<i>Roofs – Cool Roofs and Green Roofs</i>
20	<i>Site Features and Water Efficiency</i>
22	<i>Daylighting</i>

Acknowledgements

The Secretary of the Interior's Standards for Rehabilitation & Illustrated Guidelines for Rehabilitating Historic Buildings was produced by Anne E. Grimmer and Kay D. Weeks, first published in 1992 and reprinted in 1997. The *Illustrated Guidelines on Sustainability for Rehabilitating Historic Buildings*, which are presented in the same format, replace the chapter on “Energy Conservation” in the 1992 publication. They have been developed with the guidance and support of numerous public agencies, professional organizations and individuals.

All photographs and drawings included here not individually credited have been selected from National Park Service files.



Foreword

The *Illustrated Guidelines on Sustainability for Rehabilitating Historic Buildings* replaces the chapter on “Energy Conservation” in the *Illustrated Guidelines for Rehabilitating Historic Buildings* published in 1992. (This same guidance is presented in the chapter entitled “Energy Retrofitting” in the unillustrated *Guidelines for Rehabilitating Historic Buildings*.) The illustrated version of the *Guidelines for Rehabilitating Historic Buildings* was designed to further enhance overall understanding and interpretation of basic preservation principles. *The Illustrated Guidelines on Sustainability* begin with an overview focusing on the fact that historic buildings are themselves often inherently sustainable and that this should be used to advantage in any proposal to upgrade them. These guidelines offer specific guidance on how to make historic buildings more sustainable in a manner that will preserve their historic character and that will meet *The Secretary of the Interior’s Standards for Rehabilitation*. The written guidance is illustrated with examples of appropriate or “recommended” treatments and some that are “not recommended” or could negatively impact the building’s historic character. The National Park Service Branch of Technical Preservation Services has developed these illustrated guidelines in accordance with its directive to provide information concerning professional methods and techniques to ensure the preservation and rehabilitation of the historic properties that are an important part of the nation’s heritage.

THE SECRETARY OF THE INTERIOR'S STANDARDS FOR REHABILITATION

Introduction to the Standards

The Secretary of the Interior is responsible for establishing standards for all programs under Departmental authority and for advising federal agencies on the preservation of historic properties listed in or eligible for listing in the National Register of Historic Places. In partial fulfillment of this responsibility *The Secretary of the Interior's Standards for the Treatment of Historic Properties* have been developed to guide work undertaken on historic properties; there are separate standards for preservation, rehabilitation, restoration and reconstruction. *The Standards for Rehabilitation* (codified in 36 CFR 67) comprise that section of the overall treatment standards and address the most prevalent treatment. "Rehabilitation" is defined as the act or process of making possible a compatible use for a property through repair, alterations, and additions while preserving those portions or features which convey its historical, cultural, or architectural values."

Initially developed by the Secretary of the Interior to determine the appropriateness of proposed project work on registered properties supported by the Historic Preservation Fund grant-in-aid program, the Standards have been widely used

over the years—particularly to determine if a rehabilitation project qualifies as a Certified Rehabilitation for Federal Historic Preservation Tax Incentives. In addition, the Standards have guided federal agencies in carrying out their responsibilities for properties in federal ownership or control; and state and local officials in reviewing both federal and non-federal rehabilitation proposals. They have also been adopted by historic district and planning commissions across the country.

The intent of the Standards is to assist in the long-term preservation of historic materials and features. The Standards pertain to historic buildings of all materials, construction types, sizes and occupancy and include the exterior and the interior of the buildings. They also encompass the building's site and environment, including landscape features, as well as attached, adjacent or related new construction. To be certified for federal tax purposes, a rehabilitation project must be determined by the Secretary of the Interior to be consistent with the historic character of the structure(s) and, where applicable, the district in which it is located.



[1] Stained glass skylight provides natural light in a historic train station.



[2-3] Clerestory windows provide natural light in a historic industrial building: Before and after rehabilitation.



[4] Covered walkways and horizontal sun screens are distinctive and sustainable features in some mid-century modern office buildings.

As stated in the definition, the treatment “rehabilitation” assumes that at least some repair or alteration of the historic building will be needed in order to provide for an efficient contemporary use; however, these repairs and alterations must not damage or destroy materials, features or finishes that are important in defining the building’s historic character. For example, certain treatments—if improperly applied—may cause or accelerate physical deterioration of the historic building. This can include using improper repointing or exterior masonry cleaning techniques, or introducing insulation that may damage historic fabric. Any of these treatments will likely result in a project that does not meet the Standards. Similarly, exterior additions that duplicate the form, material and detailing of the historic structure to the extent that they compromise its historic character also will fail to meet the Standards.

The Secretary of the Interior's Standards for Rehabilitation

The Standards (Department of the Interior regulations 36 CFR 67) pertain to all historic properties listed in or eligible for listing in the National Register of Historic Places.

- 1) A property shall be used for its intended historic purpose or be placed in a new use that requires minimal change to the defining characteristics of the building and its site and environment.
- 2) The historic character of a property shall be retained and preserved. The removal of historic materials or alteration of features and spaces that characterize a property shall be avoided.
- 3) Each property shall be recognized as a physical record of its time, place, and use. Changes that create a false sense of historical development, such as adding conjectural features or architectural elements from other buildings, shall not be undertaken.
- 4) Most properties change over time; those changes that have acquired historic significance in their own right shall be retained and preserved.
- 5) Distinctive features, finishes, and construction techniques or examples of craftsmanship that characterize a historic property shall be preserved.
- 6) Deteriorated historic features shall be repaired rather than replaced. Where the severity of deterioration requires replacement of a distinctive feature, the new feature shall match the old in design, color, texture, and other visual qualities and, where possible, materials. Replacement of missing features shall be substantiated by documentary, physical, or pictorial evidence.



5



6

[5-6] Large windows and a roof monitor provide natural illumination in a historic industrial building.



7

[7-9] Porches and canvas awnings provide shade and keep interiors cool in historic residential and commercial buildings.



8



9

- 7) Chemical or physical treatments, such as sandblasting, that cause damage to historic materials shall not be used. The surface cleaning of structures, if appropriate, shall be undertaken using the gentlest means possible.
- 8) Significant archeological resources affected by a project shall be protected and preserved. If such resources must be disturbed, mitigation measures shall be undertaken.

- 9) New additions, exterior alterations, or related new construction shall not destroy historic materials that characterize the property. The new work shall be differentiated from the old and shall be compatible with the massing, size, scale, and architectural features to protect the historic integrity of the property and its environment.
- 10) New additions and adjacent or related new construction shall be undertaken in such a manner that if removed in the future, the essential form and integrity of the historic property and its environment would be unimpaired.



11

[11] A vestibule helps retain interior conditioned air in the living space in this historic row house.



10

[10] Wood shutters provide natural light when open and keep interiors cool when closed in historic residential buildings.



12

[12-14] Roof monitors provide natural light in historic industrial buildings



13



14

GUIDELINES FOR REHABILITATING HISTORIC BUILDINGS

Introduction to the Guidelines

The *Guidelines for Rehabilitating Historic Buildings* were initially developed in 1977 to help property owners, developers and federal managers apply *The Secretary of the Interior's Standards for Rehabilitation* during the project planning stage by providing general design and technical recommendations. Unlike the Standards, the Guidelines are not codified as program requirements.

The Guidelines are general and intended to provide guidance to help in interpreting and applying the Standards to all rehabilitation projects. They are not meant to give case-specific advice. For instance, they cannot tell owners or developers which features in a historic building are important in defining the historic character and must be retained. This case-by-case determination is best accomplished by seeking assistance from qualified historic preservation professionals in the very early stages of project planning.

Like the Standards, the Guidelines pertain to historic buildings of all materials, construction types, sizes and occupancy; and apply to exterior and interior work, as well as new addi-

tions and the building's site and environment. The Guidelines are presented in a "Recommended" vs. "Not Recommended" format. Those approaches, treatments and techniques that are consistent with *The Secretary of the Interior's Standards for Rehabilitation* are listed in the "Recommended" column on the left; those approaches, treatments and techniques which could adversely affect a building's historic character are listed in the "Not Recommended" column on the right. To provide clear and consistent guidance for property owners, developers and federal agency managers, the "Recommended" courses of action are listed in order of historic preservation concerns so that a rehabilitation project may be successfully planned and completed—one that, first, assures the preservation of a building's important or "character-defining" architectural materials, features and spaces and, second, makes possible an efficient contemporary use. The guidance that follows begins with the most basic and least invasive approaches that will help the project achieve the desired goal, before considering work that may involve more change and potentially greater impact on the historic character of the building.

Sustainability

Before implementing any energy conservation measures to enhance the sustainability of a historic building, the existing energy-efficient characteristics of the building should be assessed. Buildings are more than their individual components. The design, materials, type of construction, size, shape, site orientation, surrounding landscape and climate all play a role in how buildings perform. Historic building construction methods and materials often maximized natural sources of heating, lighting and ventilation to respond to local climatic conditions. The key to a successful rehabilitation project is to identify and understand any lost original and existing energy-efficient aspects of the historic building, as well as to identify and understand its character-defining features to ensure they are preserved. The most sustainable building may be one that already exists. Thus, good preservation practice is often synonymous with sustainability. There are numerous treatments--traditional as well as new technological innovations--that may be used to upgrade a historic building to help it operate even more efficiently. Increasingly stricter energy standards and code requirements may dictate that at least some of these treatments be implemented as part of a rehabilitation project of any size or type of building. Whether a historic building is rehabilitated for a new or a continuing use, it is important to utilize the building's inherently-sustainable qualities as they were intended. It is equally important that they function effectively together with any new measures undertaken to further improve energy efficiency.



[15] Glass skylight illuminates historic shopping arcade.

16



17



[16-18] Inherently sustainable features of historic buildings: Shutters and a deep porch keep the interior cool in a historic house in a warm climate (top); a skylight provides natural light to the interior of this mid-20th century house (center); partially glazed partitions and doors allow natural light into the corridor of a historic office building (bottom).

18



PLANNING

RECOMMENDED

NOT RECOMMENDED

Forming an integrated sustainability team when working on a large project that includes a preservation professional to ensure that the character and integrity of the historic building is maintained during any upgrades.

Omitting preservation expertise from a sustainability project team.

Analyzing the condition of inherently-sustainable features of the historic building, such as shutters, storm windows, awnings, porches, vents, roof monitors, skylights, light wells, transoms and naturally-lit corridors, and including them in energy audits and energy modeling, before planning upgrades.

Ignoring inherently-sustainable features of the existing historic building when creating energy models and planning upgrades.

Identifying ways to reduce energy use, such as installing fixtures and appliances that conserve resources, including energy-efficient lighting or energy-efficient lamps in existing light fixtures, low-flow plumbing fixtures, sensors and timers that control water flow, lighting and temperature, before undertaking more invasive treatments that may negatively impact the historic building.

Prioritizing sustainable improvements, beginning with minimally invasive treatments that are least likely to damage historic building material.

Beginning work with substantive or irreversible treatments without first considering and implementing less invasive measures.

MAINTENANCE

RECOMMENDED	NOT RECOMMENDED
Maintaining historic buildings regularly to preserve historic fabric and maximize operational efficiency.	Delaying maintenance treatments which may result in the loss of historic building fabric or decrease the performance of existing systems or features.
Retaining and repairing durable historic building materials	Removing durable historic building materials and replacing them with materials perceived as more sustainable; for instance, removing historic heart pine flooring and replacing it with new bamboo flooring.
Using environmentally-friendly cleaning products that are compatible with historic finishes.	Using cleaning products potentially harmful to both historic finishes and the environment.
Using sustainable products and treatments, such as low VOC paints and adhesives and lead-safe paint removal methods, as much as possible, when rehabilitating a historic building.	



21



22

19



20

Recommended: [19] Caulking the gap between the aluminum storm window and wood window frame helps maximize thermal efficiency in this historic residence.

[20] Using sustainable cleaning products preserves both the environment and the historic building.

Not Recommended: [21-22] The peeling paint on an exterior window sill and on the interior of a window indicates that these features have not received regular maintenance. The broken casement window hardware also needs to be repaired to make the window operable.

23



24



Recommended: [23-25] Historic exterior storm windows have been well maintained and continue to perform as intended.

Recommended: [26] The new metal interior storm window was carefully matched to the exterior window as part of the rehabilitation of this historic armory building.

WINDOWS

RECOMMENDED

NOT RECOMMENDED

Maintaining windows on a regular basis to ensure that they function properly and are completely operable.	Neglecting to maintain historic windows and allowing them to deteriorate beyond repair with the result that they must be replaced.
Retaining and repairing historic windows when deteriorated.	Removing repairable historic windows and replacing them with new windows for perceived improvement in energy performance.
Weather stripping and caulking historic windows, when appropriate, to make them weather tight.	
Installing interior or exterior storm windows or panels that are compatible with existing historic windows.	Replacing repairable historic windows with new insulated windows.

25



Not Recommended: [27] A broken sash cord can be repaired easily and does not justify replacement of the window.

26



27



WINDOWS

RECOMMENDED

NOT RECOMMENDED

Installing compatible and energy-efficient replacement windows that match the appearance, size, design, proportion and profile of the existing historic windows and that are also durable, repairable and recyclable, when existing windows are too deteriorated to repair.	Installing incompatible or inefficient replacement window units that are not durable, recyclable or repairable when existing windows are deteriorated beyond repair or missing.
Replacing missing windows with new, energy-efficient windows that are appropriate to the style of historic building and that are also durable, repairable and recyclable.	
Retrofitting historic windows with high-performance glazing or clear film, when possible, and only if the historic character can be maintained.	

31



32



Not Recommended: [31-32] Ill-fitting exterior aluminum storm windows viewed from both inside and outside are clearly not energy efficient.

Not Recommended: [30] Not only have incompatible windows that do not fit the size and shape of the historic window openings been installed, but the original openings have also been shortened to install through-the-wall HVAC units.

28



29



Recommended: [28-29] These exterior storm windows match the pane configuration of the historic interior windows in a residence and in a multi-story hotel building.

30





34



35



Recommended: [33-35] Original metal windows were appropriately repaired as part of the rehabilitation of this historic industrial building.

WINDOWS

RECOMMENDED

NOT RECOMMENDED

Retrofitting historic steel windows and curtain-wall systems to improve thermal performance without compromising their character.	
Installing clear, low-emissivity (low-e) glass or film without noticeable color in historically-clear windows to reduce solar heat gain.	Retrofitting historically-clear windows with tinted glass or reflective coatings that will negatively impact the historic character of the building.
Installing film in a slightly lighter shade of the same color tint when replacing glazing panels on historically-dark-tinted windows to improve daylighting.	Introducing clear glazing or a significantly lighter colored film or tint than the original to improve daylighting when replacing historically dark-tinted windows.

36



37

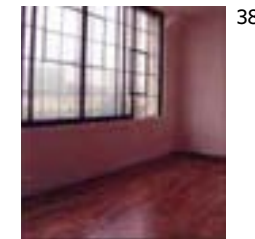

38

Recommended: [36-38] Original metal windows were retained and made operable during the rehabilitation of this historic mill complex. Installing patio slider doors as interior storm windows was a creative and successful solution to improve the energy efficiency of the existing windows.

WINDOWS

RECOMMENDED

NOT RECOMMENDED

Maintaining existing, reinstalling or installing new, historically-appropriate shutters and awnings.	Removing historic shutters and awnings or installing inappropriate ones.
Repairing or reopening historically-operable interior transoms, when possible, to improve air flow and cross ventilation.	Covering or removing existing transoms.



39
Recommended: [39-40]
 The original windows, which were deteriorated beyond repair, featured a dark tint. They were replaced with a slightly lighter-tinted glazing to improve daylighting in this mid-century modern office building.



41
Recommended: [41] Traditional canvas awnings should be retained when they exist on historic buildings.



40
Recommended: [42] Transoms and screen doors are distinctive and practical features that provided cross ventilation in this historic hotel.



42
Recommended: [43] The wall and door glazing ensures that the corridor receives natural daylight and the operable transom helps air to circulate in this historic office building.



WEATHERIZATION AND INSULATION

Recommended:
[44-45] A blower door test is a useful tool to help identify air infiltration in a historic building before undertaking weatherization or retrofit treatments.
Top Photo: Robert J. Cagnetta, Heritage Restoration, Inc.



44

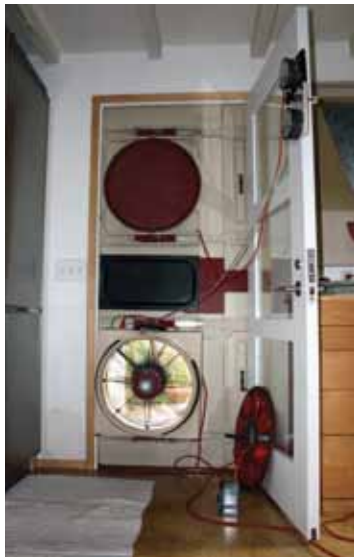

45

Recommended: [46]
A hand-held infrared scanner reveals areas that are not well insulated and that allow heat transfer through the walls of a building.



46

Recommended: [47-48] Insulation should be installed first in unfinished areas such as attics, crawl spaces and basements of residential buildings.

RECOMMENDED	NOT RECOMMENDED
Using a variety of analytical tools, such as a comprehensive energy audit, blower door tests, infrared thermography, energy modeling or daylight modeling, to gain an understanding of the building's performance and potential before implementing any weatherization or retrofit treatments.	Implementing energy-retrofit measures without first diagnosing the building's performance and energy needs.
Developing a weatherization plan based on the results of the energy analysis of the building's performance and potential.	
Eliminating infiltration first, beginning with the least invasive and most cost-effective weatherization measures, such as caulking and weather stripping, before undertaking more invasive weatherization measures.	Undertaking treatments that result in loss of historic fabric, for example, installing wall insulation that requires removing plaster, before carrying out simple and less damaging weatherization measures.
Understanding the inherent thermal properties of the historic building materials and the actual insulating needs for the specific climate and building type before adding or changing insulation.	
Insulating unfinished spaces, such as attics, basements and crawl spaces, first.	Insulating a finished space, which requires removing historic plaster and trim, before insulating unfinished spaces.



47



48

WEATHERIZATION AND INSULATION

RECOMMENDED	NOT RECOMMENDED
Using the appropriate type of insulation in unfinished spaces and ensuring the space is adequately ventilated.	Using wet-spray or other spray-in insulation that is not reversible or may damage historic materials.
	Adding insulation in cavities that are susceptible to water infiltration.
Ensuring that air infiltration is reduced before adding wall insulation.	Insulating walls without first reducing air infiltration.
Installing appropriate wall insulation, only if necessary, after lower impact treatments have been carried out.	Installing wall insulation that is not reversible and that may cause damage to historic building materials.
	Installing insulation on the exterior of a historic building, which results in the loss of historic materials and may alter the proportion and relationship of the wall to the historic windows and trim.
Removing interior plaster only in limited quantities and when absolutely necessary to install appropriate insulation.	Removing all interior plaster to install appropriate insulation.
Replacing interior plaster—removed to install insulation—with plaster or gypsum board to retain the historic character of the interior, and in a manner that retains the historic proportion and relationship of the wall to the historic windows and trim.	Replacing interior plaster—removed to install insulation—with gypsum board that is too thick and that alters the historic proportion and relationship of the wall to the historic windows and trim.
Reinstalling historic trim that was removed to install insulation.	Replicating trim rather than retaining and reinstalling historic trim that is repairable.

Not Recommended: [49] The original proportion and relationship of the wall to the door trim has been all but lost because the gypsum board installed was too thick.

[50-51] When wall insulation was installed here the walls were furred out, which created deep, historically inappropriate window recesses. The repairable historic trim was also not reinstalled.



49



50



51



52



53

Recommended: [52-53] The original proportion and relationship of the wall to the windows and trim, which is important in defining the character of these historic interior spaces, has been retained here.



54

Recommended: [54] This rigid insulation has been correctly installed in the wall cavity so that when the gypsum board is hung the original proportion and relationship of the wall to the trim will be retained.
Photo: Robert J. Cagnetta, Heritage Restoration, Inc.

HEATING, VENTILATING AND AIR CONDITIONING (HVAC) AND AIR CIRCULATION

RECOMMENDED

NOT RECOMMENDED

Retaining and maintaining functional and efficient HVAC systems.	Replacing existing HVAC systems without testing their efficiency first.
Upgrading existing HVAC systems to increase efficiency and performance within normal replacement cycles.	Replacing HVAC systems prematurely when existing systems are operating efficiently.
Installing an energy-efficient system that takes into account whole building performance and retains the historic character of the building and site when a new HVAC system is necessary.	Installing an inefficient HVAC system or installing a new system based on pre-retrofit building performance when a smaller system may be more appropriate.



55

Recommended: [55-57]
Wood vents in the gable ends of a historic house and a barn and cast-iron oval vents in a masonry foundation traditionally helped air circulate.



56



57

HEATING, VENTILATING AND AIR CONDITIONING (HVAC) AND AIR CIRCULATION

RECOMMENDED

NOT RECOMMENDED

Supplementing the efficiency of HVAC systems with less energy-intensive measures, such as programmable thermostats, attic and ceiling fans, louvers and vents, where appropriate.	
Retaining or installing high efficiency, ductless air conditioners when appropriate, which may be a more sensitive approach than installing a new, ducted, central air-conditioning system that may damage historic building material.	Installing through-the-wall air conditioners, which damages historic material and negatively impacts the building's historic character.
	Installing a central HVAC system in a manner that damages historic building material.



60

Recommended: [60] Original radiators that are still functional and efficient were retained in the rehabilitation of this historic house.

58



Recommended: [58] Ceiling fans enhance the efficiency of HVAC systems in historic buildings.

59



Recommended: [59] Installing a programmable thermostat can help existing systems to operate more efficiently.



61

Not Recommended: [61] The cuts made in the brick and the decorative stone trim to install through-the-wall air conditioners have not only destroyed building material, but have also negatively impacted the character of this historic apartment building.

62



HEATING, VENTILATING AND AIR CONDITIONING (HVAC) AND AIR CIRCULATION

RECOMMENDED

NOT RECOMMENDED

Installing new mechanical ductwork sensitively or using a mini-duct system, so that ducts are not visible from the exterior and do not adversely impact the historic character of the interior space.	Installing new mechanical ductwork that is visible from the exterior or adversely impacts the historic character of the interior space.
Leaving interior ductwork exposed where appropriate, such as in industrial spaces, or when concealing the ductwork would destroy historic fabric.	Leaving interior ductwork exposed in highly-finished spaces where it would negatively impact the historic character of the space.
Leaving interior ductwork exposed and painting it, when concealing it would negatively impact historic fabric, such as a historic pressed metal ceiling.	Leaving exposed ductwork unpainted in finished interior spaces, such as those with a pressed metal ceiling.
Placing HVAC equipment where it will operate effectively and efficiently and be minimally visible and will not negatively impact the historic character of the building or its site.	Placing HVAC equipment in highly-visible locations on the roof or on the site where it will negatively impact the historic character of the building or its site.

63



64



Recommended: [62-63] Carefully installed new mechanical ductwork is barely visible in the elaborately decorated ceiling of this historic theater.

[64] The ductwork has been left unpainted which is compatible with this historic industrial interior.

[65] To avoid damaging the metal ceiling, the ductwork was left exposed and it was painted to minimize its impact, thus preserving the historic character of this former bank.

65



66



Not Recommended: [66] Interior ductwork has been inappropriately left exposed and unpainted here in this traditionally-finished school entrance hall.

HEATING, VENTILATING AND AIR CONDITIONING (HVAC) AND AIR CIRCULATION

RECOMMENDED

NOT RECOMMENDED

Commissioning or examining the performance of the HVAC system and continuing to examine it regularly to ensure that it is operating efficiently.	Installing a new HVAC system without commissioning or testing its efficiency after installation.
Investigating whether a geothermal heat pump will enhance the heating and cooling efficiency of the building before installing one.	Installing a geothermal heat pump without evidence that it will improve the heating and cooling efficiency of the building.
	Installing a geothermal system where there is a significant landscape or where there are archeological resources that could be damaged.



67

Recommended:[67] A professional energy auditor analyzes the performance of an existing furnace to ensure it is operating efficiently.

[68-69] A geothermal system, evidenced by a panel in the sidewalk, was installed on the site of this historic firehouse during rehabilitation.



68



70

Recommended: [70-71] A geothermal system was installed on the property of this historic mansion, but only after an archeological investigation was conducted of the grounds.



71



69

SOLAR TECHNOLOGY

72



73



Recommended: [72-73] Solar panels were installed appropriately on the rear portion of the roof on this historic row house that are not visible from the primary elevation.

RECOMMENDED

NOT RECOMMENDED

Considering on-site, solar technology only after implementing all appropriate treatments to improve energy efficiency of the building, which often have greater life-cycle cost benefit than on-site renewable energy.	Installing on-site, solar technology without first implementing all appropriate treatments to the building to improve its energy efficiency.
Analyzing whether solar technology can be used successfully and will benefit a historic building without compromising its character or the character of the site or the surrounding historic district.	Installing a solar device without first analyzing its potential benefit or whether it will negatively impact the character of the historic building or site or the surrounding historic district.
Installing a solar device in a compatible location on the site or on a non-historic building or addition where it will have minimal impact on the historic building and its site.	Placing a solar device in a highly-visible location where it will negatively impact the historic building and its site.
Installing a solar device on the historic building only after other locations have been investigated and determined infeasible.	Installing a solar device on the historic building without first considering other locations.



74

Recommended: [74] Free-standing solar panels have been installed here that are visible but appropriately located at the rear of the property and compatible with the character of this industrial site.



75

Not Recommended: [75] Solar roof panels have been installed at the rear, but because the house is situated on a corner, they are highly visible and negatively impact the character of the historic property.

SOLAR TECHNOLOGY

RECOMMENDED

NOT RECOMMENDED

Installing a low-profile solar device on the historic building so that it is not visible or only minimally visible from the public right of way: for example, on a flat roof and set back to take advantage of a parapet or other roof feature to screen solar panels from view; or on a secondary slope of a roof, out of view from the public right of way.	Installing a solar device in a prominent location on the building where it will negatively impact its historic character.
Installing a solar device on the historic building in a manner that does not damage historic roofing material or negatively impact the building's historic character and is reversible.	Installing a solar device on the historic building in a manner that damages historic roofing material or replaces it with an incompatible material and is not reversible.
	Removing historic roof features to install solar panels.
	Altering a historic, character-defining roof slope to install solar panels.
	Installing solar devices that are not reversible.
Installing solar roof panels horizontally -- flat or parallel to the roof—to reduce visibility.	Placing solar roof panels vertically where they are highly visible and will negatively impact the historic character of the building.

76



77



79



Not Recommended: [79] Although installing solar panels behind a rear parking lot might be a suitable location in many cases, here the panels negatively impact the historic property on which they are located.

Recommended: [76-77] Solar panels, which also serve as awnings, were installed in secondary locations on the side and rear of this historic post office and cannot be seen from the front of the building. [78] Solar panels placed horizontally on the roof of this historic building are not visible from below.

78



WIND POWER—WIND TURBINES AND WINDMILLS

80



Recommended: [80] It is often best to install wind-powered equipment in off-site, rural locations to avoid negatively impacting a historic building and its site.

[81] This wind turbine is located in a large parking lot next to a historic manufacturing complex and it is compatible with the character of the industrial site.

[82] This 2011 Kansas postage stamp features a traditional windmill and modern wind turbines to illustrate the importance of wind power in the growth of the state.

RECOMMENDED

Considering on-site, wind-power technology only after implementing all appropriate treatments to the building to improve energy efficiency, which often have greater life-cycle cost benefit than on-site renewable energy.

Analyzing whether wind-power technology can be used successfully and will benefit a historic building without compromising its character or the character of the site or the surrounding historic district.

Installing wind-powered equipment in an appropriate location on the site or on a non-historic building or addition where it will not negatively impact the historic character of the building, the site or the surrounding historic district.

NOT RECOMMENDED

Installing on-site, wind-power technology, without first implementing all appropriate treatments to the building to improve energy efficiency.

Installing wind-powered equipment without first analyzing its potential benefit or whether it will negatively impact the character of the historic building or the site or the surrounding historic district.

Placing wind-powered equipment on the site where it is highly visible when it is not compatible with the historic character of the site.

81



82

WIND POWER—WIND TURBINES AND WINDMILLS

RECOMMENDED	NOT RECOMMENDED
Installing wind-powered equipment on the historic building without damaging the roof or walls or otherwise negatively impacting the building's historic character.	Installing wind-powered equipment on the historic building in a manner that damages the roof, compromises its structure or negatively impacts the building's historic character.
	Removing historic roof features to install wind-powered equipment, such as wind turbines.
	Installing wind-powered equipment on the historic building that is not reversible.
	Installing wind-powered equipment on the primary façade of a historic building or where it is highly visible.
Investigating off-site, renewable energy options when installing on-site wind-power equipment would negatively impact the historic character of the building or site.	



84

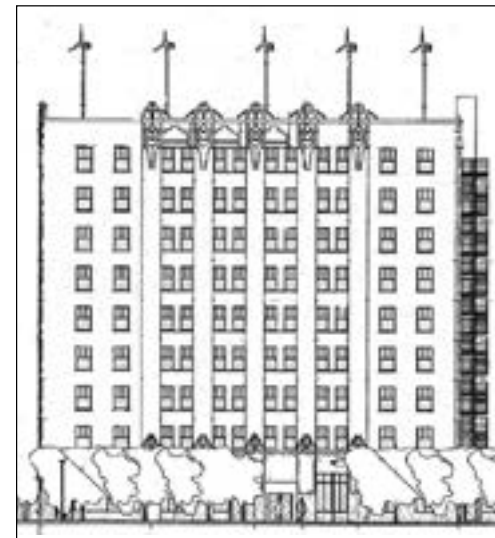

83

Not Recommended:

[83-84] This historic hotel is a prominent and highly visible local landmark, and the wind turbines proposed to be added on the roof would negatively impact its historic character.

ROOFS—COOL ROOFS AND GREEN ROOFS

85



RECOMMENDED

NOT RECOMMENDED

Retaining and repairing durable, character-defining historic roofing materials in good condition.	Replacing durable, character-defining historic roofing materials in good condition with a roofing material perceived as more sustainable.
Analyzing whether a cool roof or a green roof is appropriate for the historic building.	
Installing a cool roof or a green roof on a flat-roofed historic building where it will not be visible from the public right of way and will not negatively impact the building's historic character.	Installing a cool roof or a green roof without considering whether it will be highly visible from the public right of way and will negatively impact the building's historic character.
Selecting appropriate roofing materials and colors when putting a new cool roof on the historic building.	Installing a cool roof that is incompatible in material or color with the historic building.
Ensuring that the historic building can structurally accommodate the added weight of a green roof and sensitively improving the structural capacity, if necessary.	Adding a green roof that would be too heavy and would damage the historic building or supplementing the structural capacity of the historic building in an insensitive manner.

86



Recommended: [85-86] A cool or green roof is best installed on a flat roof where it cannot be seen from the public right of way and will not negatively impact the character of the historic building.

87



Not Recommended: [87] Historic roofing materials in good condition should be retained rather than replaced with another material perceived as more sustainable, such as, in this case, solar roofing shingles.

88



Not Recommended: [88] This new, cool white metal roof is not an appropriate material or color for this historic mid-20th century house.

ROOFS—COOL ROOFS AND GREEN ROOFS

RECOMMENDED	NOT RECOMMENDED
Ensuring that the roof is water tight and that roof drains, gutters and downspouts function properly before installing a green roof.	Installing a green roof without ensuring that the roof covering is water tight and that drainage systems function properly.
Including a moisture-monitoring system when installing a green roof to protect the historic building from added moisture and accidental leakage.	
Selecting sustainable native plants that are drought resistant and will not require excessive watering of a green roof.	
Selecting appropriately-scaled vegetation for a green roof that will not grow so tall that it will be visible above the building's historic character.	Selecting vegetation for a green roof that will be visible above the roof or parapet.



93

Not Recommended: [93] The vegetation on these green roofs has grown too tall and negatively impacts the character of these historic commercial buildings.

89



Recommended: [89-92] Low-scale and sustainable native plants are appropriate for these roof gardens on historic buildings.



90-91



92

94



95



Recommended: [94-95] Permeable pavers were used at this historic residential property for a driveway and parking (above) and a hard-packed, construction aggregate provides environmentally-friendly paths for visitors at this historic site (below).

[96] Mature trees and a water feature contribute to the sustainability of this mid-twentieth century property.

96



97



Not Recommended: [97] This tree, which was planted too close to the building, has caused the masonry wall to retain moisture that damaged the mortar and required that the brick be repointed in this area.

SITE FEATURES AND WATER EFFICIENCY

RECOMMENDED

NOT RECOMMENDED

Respecting an important cultural landscape and significant character-defining site features when considering adding new sustainable features to the site.	Installing new sustainable site features without considering their potentially negative impact on an important cultural landscape and character-defining site features.
Using to advantage existing storm-water-management features, such as gutters, downspouts and cisterns, as well as site topography and vegetation that contribute to the sustainability of the historic property.	Ignoring existing features that contribute to the sustainability of the historic property.
Adding natural, sustainable features to the site, such as shade trees, if appropriate, to reduce cooling loads for the historic building.	Removing existing natural features, such as shade trees, that contribute to the building's sustainability.
	Planting trees where they may grow to encroach upon or damage the historic building.
Using permeable paving where appropriate on a historic building site to manage storm water.	

SITE FEATURES AND WATER EFFICIENCY

RECOMMENDED	NOT RECOMMENDED
Avoiding paving up to the building foundation to reduce heat island effect, building temperature, damage to the foundation and storm-water runoff.	Paving up to the building foundation with impermeable materials.
Landscaping with native plants, if appropriate, to enhance the sustainability of the historic site.	Introducing non-native plant species to the historic site that are not sustainable.
Adding features, such as bioswales, rain gardens, rain barrels, large collection tanks and cisterns, if compatible, to the historic building site to enhance storm-water management and on-site water reuse.	

98



Recommended: [98-100] Rain gardens and rain-water collection tanks are features that may be added to a historic property to improve storm-water management and increase on-site water use.

99



100



101

Not Recommended: [101] Splash back from the impermeable concrete paving next to the foundation is damaging these stones.



102

Recommended: [102-103]
Small, covered atriums that are compatible with the character of these historic warehouses have been inserted to light the interior.



103

Not Recommended: [104-106]
Skylights added on a primary roof elevation negatively impact the character of these historic houses.



104



105



106

DAYLIGHTING

RECOMMENDED

NOT RECOMMENDED

Retaining features that provide natural light to corridors, such as partial glass partitions, glazed doors and transoms, commonly found in historic office buildings.	Removing or covering features that provide natural light to corridors, such as partial glass partitions, glazed doors and transoms, commonly found in historic office buildings.
Reopening historic windows that have been blocked in to add natural light and ventilation.	Blocking in historic window openings to accommodate new building uses.
Adding skylights or dormers on secondary roof elevations where they are not visible or are only minimally visible so that they do not negatively impact the building's historic character.	Adding skylights or dormers on primary or highly-visible roof elevations where they will negatively impact the building's historic character.
Adding a small light well or light tubes, where necessary and appropriate, to allow more daylight into the historic building.	
Inserting a small atrium, only when necessary, to allow more daylight into the building in a manner that is compatible with the historic character of the building.	Cutting a very large atrium into the historic building that is not compatible with the building's historic character.
	Creating an open, uncovered atrium or courtyard in the historic building that appears to be an outdoor space, rather than an interior space.

DAYLIGHTING

RECOMMENDED	NOT RECOMMENDED
Installing light-control devices on the historic building where appropriate to the building type, such as light shelves in industrial or mid-century modern buildings, awnings on some commercial and residential buildings and shutters on residential buildings that had them historically.	Installing light-control devices that are incompatible with the type or style of the historic building.
Installing automated daylighting controls on interior lighting systems that ensure adequate indoor lighting and allow for energy-saving use of daylighting.	
Adding new window openings on secondary and less visible facades, where appropriate, to allow more natural light into the historic building.	Adding new window openings on primary elevations that will negatively impact the character of the historic building.



110

Recommended: [110]

A clerestory window lights the interior corridor of this historic mill building.

111

[111] A limited number of new window openings may be added to non-character-defining, secondary facades to allow natural light into formerly windowless spaces.

107



Recommended: [107] Traditional canopies compatible with the industrial character of this former factory building were installed when it was converted for residential use.

[108-109] The original, partially-glazed doors and office partitions, as well as skylights, that let natural light into the corridors were retained as part of the rehabilitation of this early-20th century building.



108



109



U.S. Department of the Interior
National Park Service
Technical Preservation Services

ANN ARBOR HISTORIC DISTRICT COMMISSION

HISTORIC DISTRICT DESIGN GUIDELINES



ADOPTED: DECEMBER 13, 2012

CREDITS

Ann Arbor Historic District Commission

(Various terms 2006-2012)

John Beeson
Michael Bruner
Benjamin Bushkuhl
Diane Giannola
Kristina Glusac
Jim Henrichs
Patrick McCauley
Ellen Ramsburgh
Jennifer Ross
Lesia Rozmarek
Sarah Shotwell
Tom Stuhlberg
Robert White

Ann Arbor Discovering Downtown (A2D2) Steering Committee

Marcia Higgins, City Council
Evan Pratt, Planning Commission
Roger Hewitt, Downtown Development Authority

Downtown Ann Arbor Historic Preservation Advisory Committee

Gary Boren
Louisa Pieper
Allison Poggi
Ethel Potts
Wendy Woods

City of Ann Arbor

301 E. Huron Street
Ann Arbor, MI 48104
www.a2gov.org

Kristine Kidorf, Project Manager
Dan Bollman, Consultant
Wendy Rampson
Jill Thacher
Katie Remensnyder

Winter & Company

Noré Winter
Abe Barge



ADDITIONAL INFORMATION

Michigan State Historic Preservation Office

735 E. Michigan Avenue
P.O. Box 30044
Lansing, MI 48909
www.michigan.gov/shpo

National Park Service Technical Preservation Services

www.nps.gov/tps



National Park Service Preservation Briefs

[www.nps.gov/tps/how-to-preserve/
briefs.htm](http://www.nps.gov/tps/how-to-preserve/briefs.htm)

The Secretary of the Interior's Standards for Rehabilitation

[www.nps.gov/tps/standards/rehabili-
tation.htm](http://www.nps.gov/tps/standards/rehabilitation.htm)



TABLE OF CONTENTS

Introduction	Intro-1
The Historic District Commission	Intro-1
Tax Credits for Preservation	Intro-2
Basic Preservation Principles	Intro-2
Applicability of the Design Guidelines	Intro-3
Who Uses the Design Guidelines	Intro-4
Relationship with Other Regulations	Intro-4
How to Use the Design Guidelines	Intro-5
Which Design Guidelines Apply to Your Project?	Intro-6
Chapter 1: Historic Resources in Ann Arbor	1-1
Historic Architectural Styles in Ann Arbor	1-1
Greek Revival	1-2
Italianate	1-3
Romanesque Revival	1-4
Queen Anne	1-5
Colonial Revival	1-6
20th Century Commercial Style	1-7
Beaux Arts	1-8
Art Deco & Art Moderne	1-9
Vernacular	1-10
Craftsman / Bungalow	1-11
Historic Districts in Ann Arbor	1-12
Ann Street	1-13
Broadway	1-14
Cobblestone Farm	1-16
Division Street	1-17
Northern Brewery	1-19
Old Fourth Ward	1-20
Old West Side	1-22
Washtenaw - Hill	1-24
Downtown Historic Districts	1-25
Chapter 2: The Secretary of the Interior’s Standards for Rehabilitation	2-1
Chapter 3: Design Guidelines for All Historic Properties	3-1
Additions to Historic Structures	3-1
Guidelines for All Additions	3-2
Additions to Historic Residential Structures	3-3
Additions to Historic Commercial Structures	3-4
Historic Building Elements (Commercial or Residential)	3-5
Windows	3-5
Wood Siding, Trim and Architectural Details	3-11
Synthetic Replacement Siding	3-12
Masonry Walls, Trim and Foundations	3-13
Roof Shape, Materials, Gutters, Dormers and Chimneys	3-14
Barrier Free Accommodations, Safety Codes, Fire Escapes	3-17
Site Features on Historic Properties (Commercial or Residential)	3-18
Paved Areas	3-18
Lighting	3-20
Solar Panels	3-21

Chapter 4: Design Guidelines for All Historic Residential Properties	4-1
Historic Residential Building Elements	4-1
Doors	4-1
Awnings	4-6
Porches	4-7
Decks and Patios	4-14
Satellite Dishes, Antennas, Mechanical Equipment	4-15
Accessory Structure Building Elements	4-16
Site Features on Historic Residential Properties	4-17
Landscape Features	4-18
Fencing and Walls	4-19
Chapter 5: Design Guidelines for Historic Commercial Properties	5-1
Historic Commercial Building Elements	5-1
Storefronts	5-2
Entries	5-6
Awnings & Banners	5-7
Signs	5-10
Use of Metal	5-12
Mechanical Equipment	5-13
Chapter 6: Design Guidelines for Relocation & Demolition	6-1
Relocation of Historic Structures	6-1
Demolition of Historic Structures	6-3
Notice to Proceed	6-3
Evidence of Undue Financial Hardship	6-3
Chapter 7: Design Guidelines for New Construction	7-1
General Principles for New Construction in Historic Districts	7-2
Guidelines for All New Construction	7-3
New Construction in Historic Residential Settings	7-4
Guidelines for New Construction in Historic Residential Settings	7-4
Guidelines for New Accessory Structures in Historic Residential Settings	7-5
New Construction in Historic Commercial Settings	7-6
Downtown Historic Districts	7-7
Relationship with Downtown Ann Arbor Design Guidelines	7-8
Site Planning for New Construction Downtown	7-9
Building Massing for New Construction Downtown	7-13
Building Elements for New Construction Downtown	7-17
Downtown Character Areas	7-19
Appendices	APP-1
Appendix A: Glossary of Terms	APP-1
Appendix B: Window Element Measurements Worksheet	APP-5

INTRODUCTION

Ann Arbor’s historic buildings tell the story of Ann Arbor, from the homes and businesses of the city’s earliest residents to the development of the University of Michigan and the neighborhoods and businesses that support the community’s growth. We value our historic resources because of their beauty, because of the people that lived and worked there, and because of their relationship to the development of our culture. We value them because they help us understand who we are in a tangible way.

Preservation protects history and contributes to a sense of place. It promotes a high quality of life, stabilizes neighborhoods, increases property values and addresses livability concerns. The city’s growth management, environmental concerns and economic goals are also supported by preservation efforts.

This chapter of the Ann Arbor Historic District Design Guidelines describes basic principles of historic preservation as well as the applicability, users and use of the design guidelines. Introductory information is also provided regarding the Ann Arbor Historic District Commission and direct economic incentives for historic preservation.



Preservation promotes a high quality of life, stabilizes neighborhoods, increases property values and addresses livability concerns.

IN THIS CHAPTER

The Historic District Commission	Intro-1
Tax Credits for Preservation	Intro-2
Basic Preservation Principles	Intro-2
Applicability	Intro-3
Who Uses Design Guidelines?	Intro-4
Relationship with other regulations	Intro-3
How to Use the Design Guidelines	Intro-5
Which Design Guidelines Apply to your Project?	Intro-6



Historic buildings tell the story of the neighborhoods and businesses that supported the community’s growth.

**FOR MORE INFORMATION
ON HISTORIC PRESERVATION
IN ANN ARBOR**

Contact the Historic District
Commission at:

Phone: 734-794-6265

Web: <http://www.a2gov.org/HDC>

**FOR MORE INFORMATION
ON TAX CREDITS**

Visit the State of Michigan Web
Site at:

www.michigan.gov/hpcredit

Visit the National Park Service
Web Site at:

<http://www.nps.gov/tps/tax-incentives.htm>

The Historic District Commission

The Ann Arbor Historic District Commission was created in 1973 to protect and preserve Ann Arbor's Historic Resources. The Commission consists of seven members appointed by the Mayor and City Council. All members must be residents of the city and the majority shall have clearly demonstrated interest in or knowledge of historic preservation. Section 1:191 of Chapter 8 of Title I of the Code of the City of Ann Arbor also states that at least two members shall be appointed from a list submitted by a local historic preservation organization, if possible one shall be a graduate of an accredited school of architecture, and if possible one shall meet the professional qualifications for history as defined by the Secretary of the Interior's Historic Preservation Professional Qualifications Standards. Members serve three year terms, and meetings are generally held the second Thursday of every month.

Tax Credits for Historic Preservation

Preservation supports local quality of life as well as the long term economic sustainability of the community. Owners of income producing properties that are listed on the National Register of Historic Places who undertake a substantial rehabilitation of their property and have the work approved by the National Park Service can apply for a federal income tax credit equal to 20% of the cost of the rehabilitation.

Basic Preservation Principles

While all work within Ann Arbor's historic districts must be reviewed, not all properties within the districts are considered historic resources. Newer construction and buildings that have been significantly altered may be considered non-contributing resources.

Resources within locally designated historic districts are defined as contributing or non-contributing when the district is surveyed and during the preparation of the study committee report. Where this information does not exist the staff of the Historic District Commission will prepare information and history about the property in order to determine if the resource contributes to the historic character of the district. The State Historic Preservation Office and Secretary of the Interior provide a definition for historic and non-historic resources.

Contributing Resources. A contributing (historic) resource, is one that adds to the historic association, historic architectural quality, or archaeological values for which a property is significant because it was present during the period of significance, relates directly to the documented significance, and possesses historic integrity.

Non-Contributing Resources. A non-contributing (non-historic) resource is one that does not add to the historic architectural qualities or historic association of a district because it was not present during the period of significance, does not relate to the documented significance, or due to alteration, additions, and other changes it no longer possesses historic integrity.



In Michigan, owners of historic homes or other resources within a historic district may qualify for federal tax credits.

Applicability of the Design Guidelines

These design guidelines apply to repair, maintenance, rehabilitation and new construction projects undertaken within Ann Arbor's locally designated historic districts. A map of the city's historic districts is provided in *Chapter 1: Historic Resources in Ann Arbor*.

The design guidelines in this document should be consulted for projects which may affect the integrity of historic resources. While ordinary repair and maintenance are encouraged, seemingly minor alterations to a historic structure, such as enclosing a storefront or changing windows, can have a dramatic effect on the character of a historic structure and therefore, are of concern. The following is a list of common changes that can have a significant impact on the integrity of a historic structure or district:

- Alteration or restoration of exterior features of a historic building
- Removal or demolition, in whole or in part, of a historic building
- Alteration of a storefront
- Application of new exterior cladding material
- Addition of a new window or door opening
- Alteration of the site, such as creation of a driveway or a parking area
- Alteration or application of architectural features and other miscellaneous modifications, such as cornices and bulkheads.
- Construction of a new addition
- Construction of a new building within a historic district

This list is not all inclusive, but is indicative of the types of changes to which these design guidelines apply. Work to non-historic resources must still be compatible with the surrounding historic district, however there is usually more flexibility with what work can be approved.

For questions regarding permits and the applicability of these guidelines, please contact the Historic District Commission.



The design guidelines apply to a range of projects undertaken in historic districts including the maintenance and rehabilitation of historic building elements such as light fixtures.



A number of historic residential structures in downtown Ann Arbor have been converted into businesses.

THE HISTORIC PRESERVATION ORDINANCE

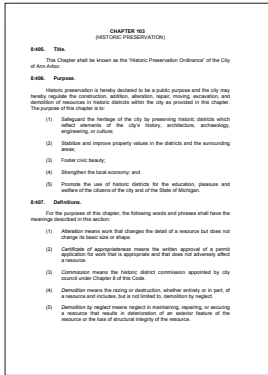

These design guidelines are enabled by Ann Arbor’s Historic Preservation Ordinance (Chapter 103 of the City Code). Policies promoted by the ordinance include:

- Safeguarding the heritage of the city by preserving historic districts which reflect elements of the city’s history, architecture, archaeology, engineering, or culture
- Stabilizing and improving property values in the historic districts and surrounding areas
- Fostering civic beauty
- Strengthening the local economy
- Promoting the use of historic districts for the education, pleasure and welfare of the citizens of the city and of the State of Michigan

Who Uses the Design Guidelines?

The Historic District Design Guidelines will be used by the following groups and individuals:

- **The General Public** may use the design guidelines to obtain information about historic resources in the community.
- **Property Owners, Business Owners and Architects** should use the design guidelines when planning, designing or undertaking projects in historic districts.
- **City Staff** will use the guidelines when advising property owners and making recommendations to the Historic District Commission.
- **The Historic District Commission** will use the guidelines to review projects proposed within historic districts. Compliance with the design guidelines will be a primary consideration in the issuance of a Certificate of Appropriateness.

Relationship with Other Regulations

The Historic District Design Guidelines are part of a system of regulations that shape development in Ann Arbor’s locally designated historic districts. Other applicable policies and regulations include the Historic Preservation Ordinance, base zoning regulations, the building code and the Downtown Ann Arbor Design Guidelines (for projects in historic districts within downtown Ann Arbor). Additional information is provided in the “Which Design Guidelines Apply to My Project?” section of this chapter.

Repair, Replacement or Rehabilitation of Historic Resources. This type of project is primarily regulated by the Historic Preservation Ordinance and the Historic District Design Guidelines.

New Construction or Additions in Historic Districts. This type of project is subject to base zoning regulations, the Historic Preservation Ordinance and the Historic District Design Guidelines. For projects in downtown historic districts, the Downtown Ann Arbor Design Guidelines are also applicable.

All new buildings and additions in historic districts are subject to the requirements of the base zoning. The base zoning establishes the general use and design requirements for development while the design guidelines documents provide more detailed criteria to shape project design. The design standards within the base zoning are prescriptive requirements. The design guidelines are performance-oriented and provide greater flexibility.

Guidelines and recommendations for new additions and buildings can be found on the National Park Service website, <http://www.nps.gov/tps>.

How to Use the Historic District Design Guidelines

These guidelines will be used by the Historic District Commission in conjunction with the Secretary of the Interior's Standards for Rehabilitation and Guidelines and city code when reviewing and approving projects in Ann Arbor's locally designated historic districts. Property owners, business owners and architects should also use the guidelines when planning projects in historic districts.

The Commission will consider each project on a case-by-case basis to determine compliance with relevant design guidelines. In some cases, certain guidelines will not be relevant. For example, when a project involves the repair or replacement of a historic window, the design guidelines for new construction would not apply. The "Which Design Guidelines Apply to My Project?" section on the next page provides additional details.

Each project involves a unique combination of preservation and design variables. These variables generally include analysis of the district's character-defining historic features and the proposed project's compatibility with those features. If a proposed project is not compatible, there may be design alternatives that would bring it into compliance with the guidelines.

There is a dynamic interaction among the guidelines and the design variables that they address. In some cases, one guideline may be more directly met, while another would be less so. Overall, however, the intent of the guidelines must be sufficiently met. This means that, in some cases, compliance with some guidelines must be balanced with that of others. While the intent is for all relevant guidelines to be adequately met for each project, certain ones will be more important than others based on the context and the specific aspects of an individual design.

In other cases, a design proposal may have certain aspects that do not appear to fit within the specific directive in a particular design guideline. In such a case, the Historic District Commission must find that the broader intent of the guideline and the Secretary of the Interior's Standards would be adequately addressed. This provides a degree of flexibility, while maintaining consistency in the application of the principles underlying the design guidelines.

These guidelines do not cover every possible type of work that may be contemplated in historic districts. The final decision on whether to approve a specific project rests with the Ann Arbor Historic District Commission.

THE DOWNTOWN ANN ARBOR DESIGN GUIDELINES

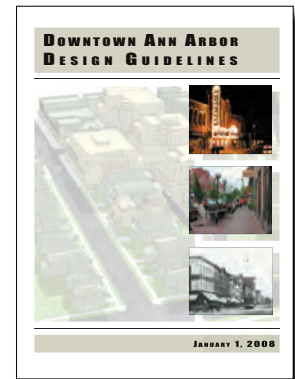

A separate Downtown Ann Arbor Design Guidelines document provides extensive guidance for the design of new construction downtown and is applicable to new construction on a downtown site within a historic district.

The relationship between the Downtown Ann Arbor Design Guidelines and the Historic District Design Guidelines is described in Chapter 7: New Construction.

Which Design Guidelines Apply to Your Project?

This chart illustrates how individual chapters of the guidelines apply to specific property types and construction projects. Contact the Ann Arbor Historic District Commission to determine if a property is designated as “contributing.”

Chapters marked with a check mark apply to the type of work listed in the left column of the table: ✓

As noted in the table, the separately published Downtown Ann Arbor Design Guidelines are also applicable to some projects.

Type of work:	Chapters to use:	Introduction	Chapter 1: Historic Resources in Ann Arbor	Chapter 2: The Secretary of the Interior’s Rehabilitation Standards	Chapter 3: Design Guidelines for All Historic Properties	Chapter 4: Design Guidelines for Historic Residential Properties	Chapter 5: Design Guidelines for Historic Commercial Properties	Chapter 6: Design Guidelines for Relocation & Demolition	Chapter 7: Design Guidelines for New Construction	Downtown Ann Arbor Design Guidelines (published separately)
Work on a “contributing” residential property in a historic district		✓	✓	✓	✓	✓				
Work on a “contributing” commercial property in a historic district		✓	✓	✓	✓		✓			
Work on a “non-contributing” property in a historic district		✓	✓	✓	✓					
An addition to a residential or commercial property in a historic district		✓	✓	✓	✓	✓	✓			
Relocation or demolition of a “contributing” residential or commercial structure in a historic district		✓	✓	✓				✓		
A new residential construction project in a historic residential setting within a historic district		✓	✓	✓	✓	✓			✓	
A new residential or commercial construction project in a historic commercial setting within a historic district outside of downtown		✓	✓	✓	✓		✓		✓	
A new residential or commercial construction project in a historic commercial setting within a downtown historic district		✓	✓	✓					✓	✓

CHAPTER 1: HISTORIC RESOURCES

IN ANN ARBOR

Ann Arbor's historic districts and buildings reflect the evolution of the community. This chapter describes the city's existing historic resources including the mix of architectural styles and the history and context of locally designated historic districts. It should be used to help identify design responses that are appropriate to a particular setting and style of structure.

Historic Architectural Styles in Ann Arbor

The architectural styles seen in Ann Arbor's historic districts are representative of American architecture constructed between 1840 to about 1950. Building styles changed frequently, just as trends in clothing, art, and music have varied throughout American history.

The architectural styles described on the following pages do not represent all of the historic architectural styles seen in Ann Arbor, but do represent some of the most common types. The style summaries and key identifying features should be used when considering how the design guidelines will apply to an individual project involving an existing historic structure. They will help identify which features are most closely associated with a particular style and therefore most important to preserve.



A building boom following the Civil War transformed the area that is now the Main Street Historic District into one of the most important commercial centers west of Detroit.

IN THIS CHAPTER

Historic Architectural Styles	1-1
Historic Districts	1-12



The State Street Historic District is an important secondary commercial center.



The Old Fourth Ward Historic District is primarily residential but does include a number of churches.



The Kempf House is a Greek Revival style structure in the Division Street Historic District.

GREEK REVIVAL (1820 – 1860)

Greek Revival style buildings were popular in Ann Arbor between 1840 and 1860. As a new democracy, Americans identified with the ancient democracies of Greece and wanted their architecture to illustrate those ideals. In Ann Arbor, examples of this style are primarily residential, with the most well known example being the Kempf House in the Division Street Historic District.



Identifying Features

Low-pitched, front-gable roof with full or broken pediment (temple front)

Classical detailing such as heavy cornices, simple moldings, and columns and pilasters

Rectangular building shape



The Kempf House at 312 South Division Street illustrates several key identifying features of Greek Revival Style architecture. It is in the Division Street Historic District.

ITALIANATE (1855-1885)

Italianate architecture was primarily influenced by the architecture of the Italian Renaissance including countryside villas and palaces. It is a departure from the simplicity of the Greek Revival style and illustrates the growing influence of European styles on American architecture. The style was applied to residences and commercial buildings, and many downtown commercial buildings are in this style.



Identifying Features

Deep overhanging eaves with carved brackets on residences; elaborate, heavy cornices with brackets on commercial buildings

Corner quoins and corbelled brickwork

Tall narrow windows, often with rounded or segmented arches

The commercial building at 122 West Washington illustrates several key identifying features of Italianate style architecture. It is in the Main Street Historic District.



ROMANESQUE REVIVAL (1880-1895)

This style takes design elements from Romanesque architecture, a style of Medieval architecture, to create “heavy” buildings emphasizing thick, stone walls and deep-set doors behind Roman arches. It is sometimes called “Richardson Romanesque” after noted architect H. H. Richardson who popularized the style. Commonly used for churches and libraries, some large residences were constructed in the style, but it is more often found in commercial buildings.

Identifying Features

- Complex masonry details often combining brick and stone
- Large cornice or parapet wall on commercial buildings, often in a peaked form
- Wide, rounded arches over deep set doors and windows
- Windows grouped in an arcade



The commercial building at 113 West Liberty illustrates several key identifying features of Romanesque architecture. It is in the Liberty Street Historic District.

QUEEN ANNE (1875-1900)

Named and popularized by a group of English architects, the Queen Anne style has asymmetrical floor plans and irregular roof shapes. Proponents of the style found their inspiration in the medieval art and architecture that preceded its namesake's reign as the Queen of England from 1702 to 1714. The style's compatibility with earlier American Colonial styles evoked nostalgia and helped popularize it in the United States. The diversity of forms and materials available at the time allowed a great variety within Queen Anne style architecture.



The residential building at 120 North Division illustrates several key identifying features of Queen Anne style architecture. It is in the Division Street Historic District.

Identifying Features

- ← Rounded or polygonal towers
- ← Windows of many shapes, sometimes with borders of small squares of tinted glass
- ← Decorated wall surfaces including use of carved trim pieces
- ← Use of pressed metal to imitate stone features
- ← Decorative brick patterns in commercial buildings including corbelling, bands of molded brick or terra cotta and inset panels



The Queen Anne Style commercial building at 221 East Washington Street is in the Main Street Historic District.

COLONIAL REVIVAL (1876-1955)

Spurred in part by the American Centennial, the Colonial Revival style replicated details of American colonial architecture and adapted it to the massing and forms of the period. The style typically includes rectangular floor plans and symmetrical façades. Colonial Revival architecture is quite common and was the dominant residential style in the twentieth century. In addition to residential construction, the style was also used for monumental commercial buildings such as schools and banks.



Identifying Features

Small overhangs with dentil moldings

Residential examples usually have wood siding and wood details

Fanlights above doors; Palladian windows and double-hung sash with small panes

Center entrances

Commercial examples typically of red brick with stone trim and wood moldings

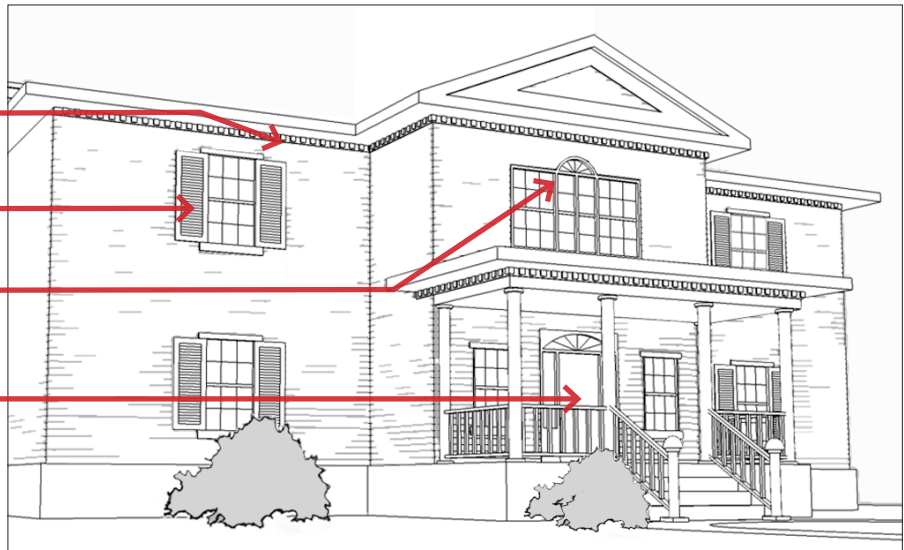

The residential building at 1310 Hill Street illustrates several key identifying features of Colonial Revival style architecture. It is in the Washtenaw - Hill Historic District.

20th CENTURY COMMERCIAL STYLE

20th Century Commercial Style design first appeared in Chicago and was influenced by industrialization in the early 1900s. In response to pressure for utilitarian buildings and because of advances in steel structural systems, these buildings could be as tall as sixteen stories. There was often a high ratio of window to wall area and windows often had a rectangular shape. The style generally includes only limited ornamentation, although when it occurred often reflected earlier styles.

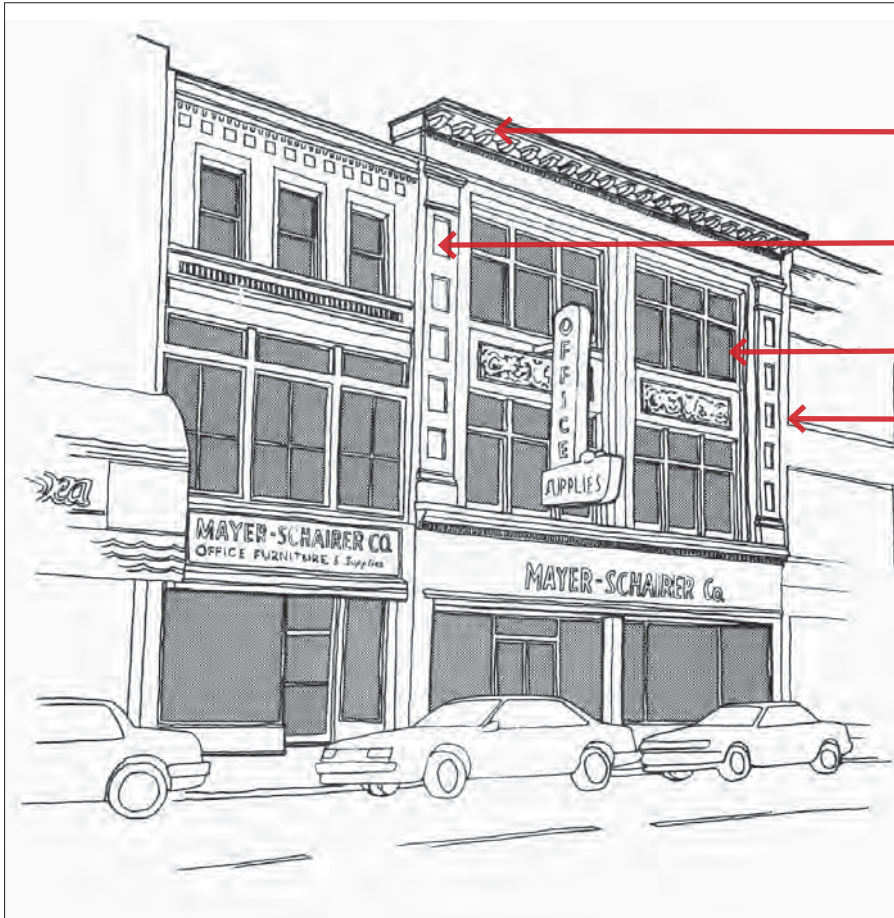

Identifying Features

- Level roofline finished by a bold band of masonry or terra cotta, or by a simple, deep, projecting cornice
- Balancing of horizontal and vertical lines
- Large, rectangular windows that create visual interest by their placement
- Constructed of brick or terra cotta on a steel frame

The 20th Century Commercial Vernacular style buildings at 112 South Main Street are in the Main Street Historic District.



BEAUX ARTS (1890-1925)

The City Beautiful movement, inspired by Chicago's Columbian Exposition in 1893, popularized the Beaux Arts style. The simple, classical design was used in monumental buildings suitable for banks, post offices, and civic buildings.

Identifying Features

Symmetrical façade with contrasts of light and shadow

Decorative urns, swags, medallions, and balustrades

Classical detailing such as paired columns and pilasters that run the full height of the building

Large openings and grand stairways

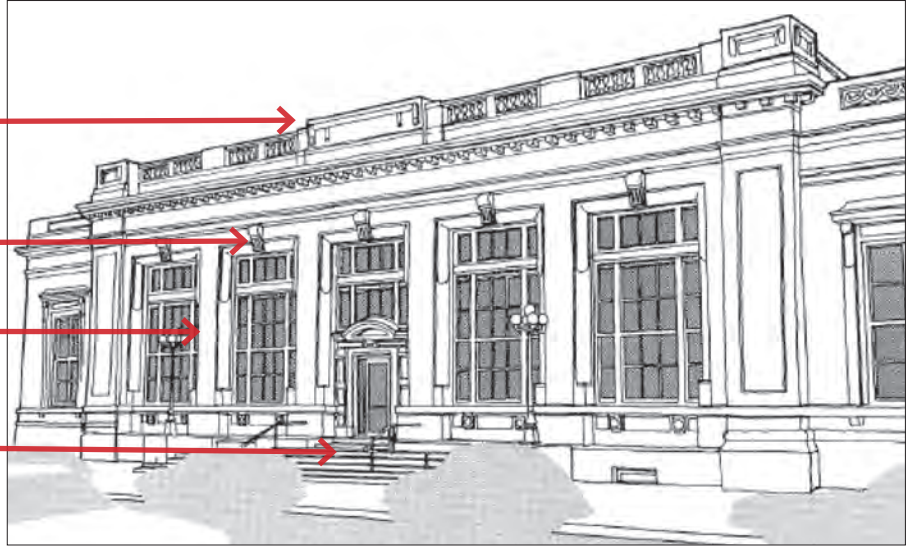

The Beaux Arts style building at 120 North Main Street is in the Main Street Historic District and houses administrative offices for Washtenaw County.

ART DECO & ART MODERNE (1910 – 1940)

Art Deco architecture was meant to make a strong, modern statement and was not influenced by historic styles. Art Deco emphasizes the vertical direction and was typical of the 1910s and 1920s. Art Moderne emphasizes the horizontal direction and is typical of the 1930s. Both styles celebrated technological progress and incorporated an aesthetic that referenced industrial machinery. The streamlined design of Art Deco and Art Moderne structures included repetitive geometric elements.



Identifying Features

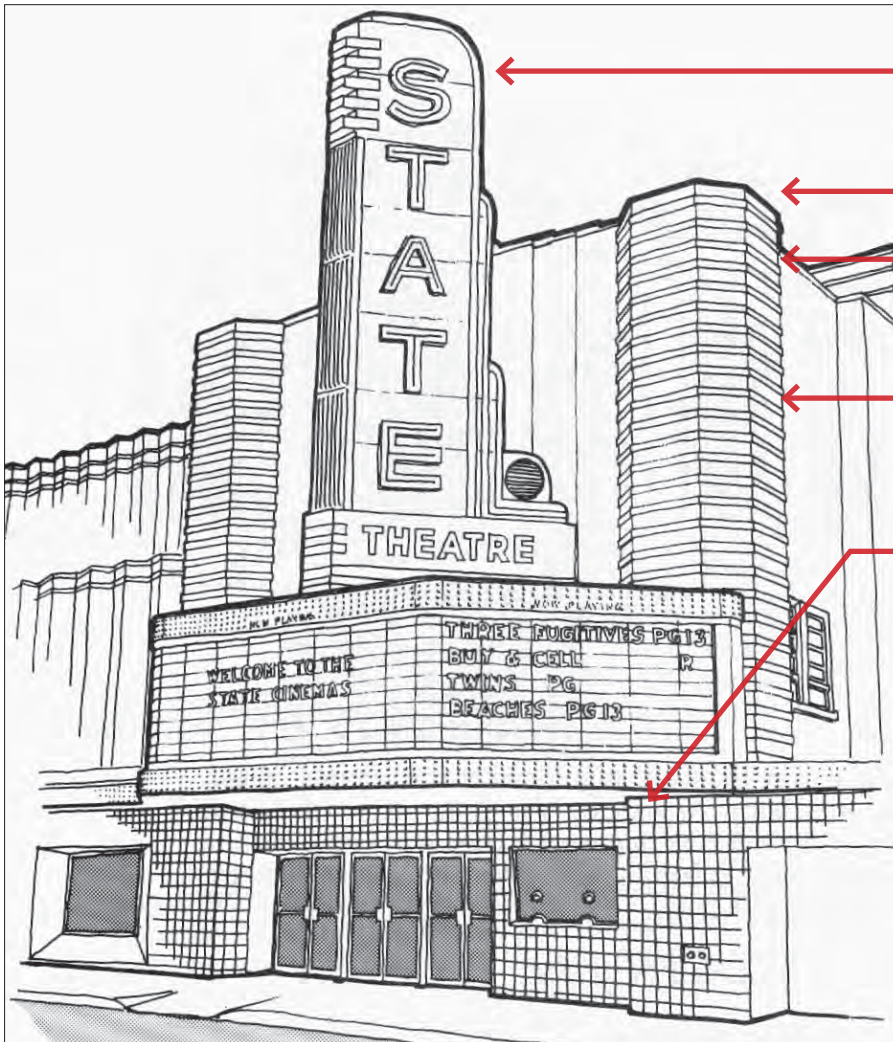

Bold ornamentation in low-relief geometric designs or stylized natural motifs that are repetitive

Linear or streamlined forms

Stepped fronts, curved windows, polychromatic surfaces

Fluted piers and pilasters to emphasize verticality

Use of new industrial materials

The State Theater is a prominent example of Art Deco architecture in the State Street Historic District.



VERNACULAR (1820-1920)

A regionally expressed type of house that spans many architectural styles and blends styles, this house always has a front-facing gable and front porch, and a steeper-pitched roof than is found in Greek Revival or Italianate. These houses, which were usually built by the homeowner or builder with locally available materials, typically had a rectangular floor plan and often incorporated decorative details from past styles.

Identifying Features

Front-facing gable roof

Steeply pitched roof

Decorative elements

Front porch

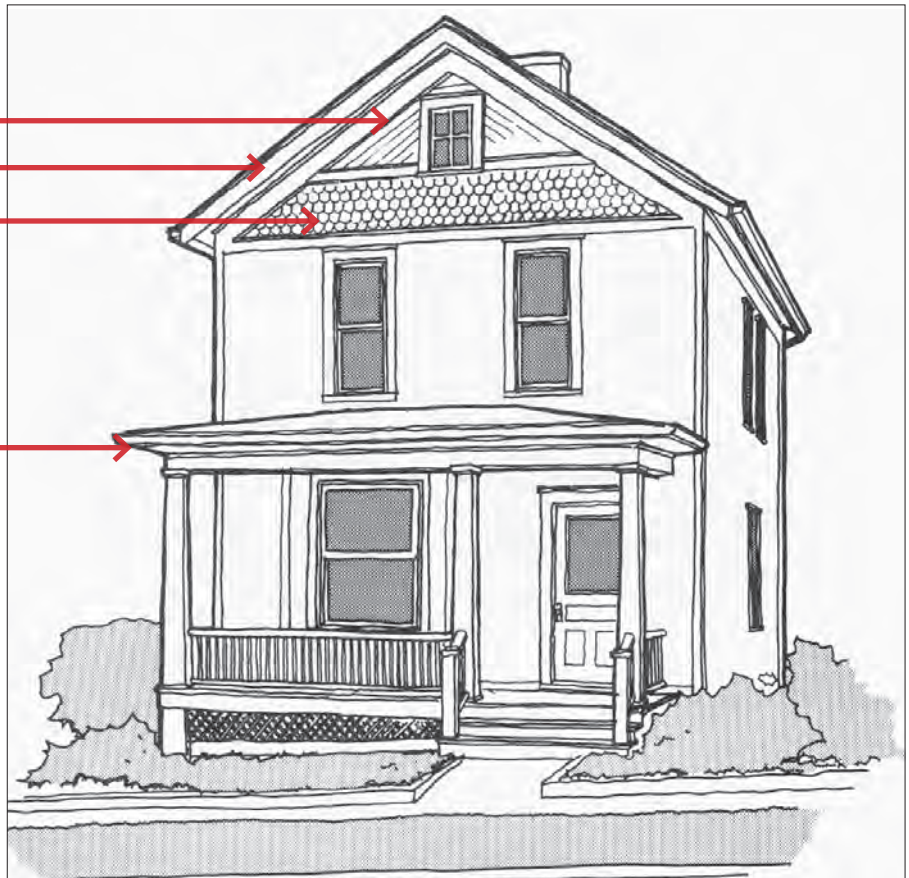

The home at 308 West Huron Street is an example of Homestead Vernacular style architecture in the Old Fourth Ward Historic District.

BUNGALOW or CRAFTSMAN (1905-1930)

Bungalow denotes a general type rather than a specific style of architecture. Although residential bungalows display a variety of materials and details, they are easily recognized by their wide, low-pitched roofs and broad front porches. They became very popular in the United States in the early 20th Century and were rooted in the English Arts and Crafts movement. Bungalows range in scale from modest one-story dwellings to large two or two-and-a-half story homes. They often feature art glass and have exposed brackets and rafters and combinations of different textures such as cobblestones and shingles.

Created in Southern California by the architects Greene and Greene, the Craftsman style home was a very popular type of bungalow influenced by the English Arts and Crafts movement. The popularity of the style grew with the publication of pattern books and Gustave Stickly's magazine, "The Craftsman." The style carried the message of simplicity, harmony with nature, and promotion of craftsmanship.

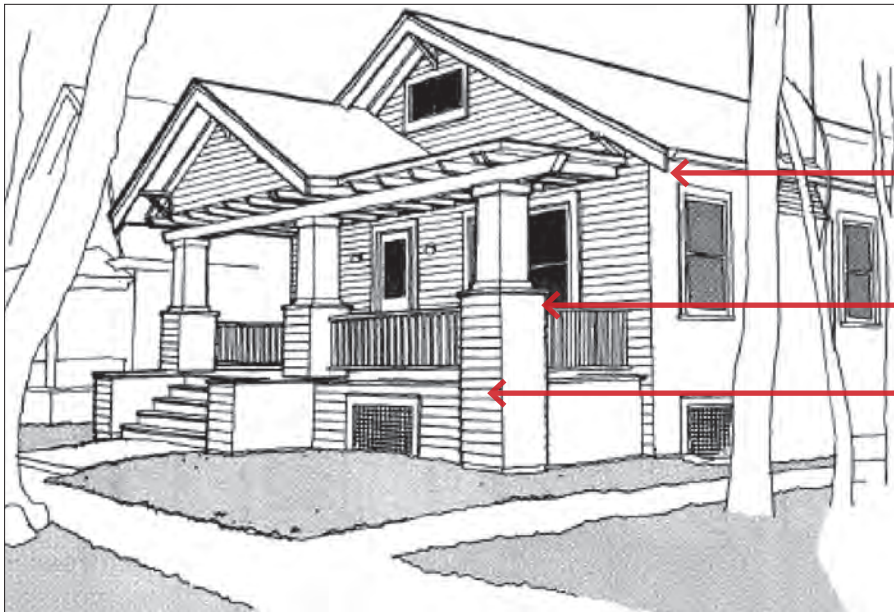

Identifying Features

- ← Massive gable or hipped roof with wide overhang and exposed rafter tails
- ← Prominent porches, verandas, or terraces
- ← Use of wood and stone as primary materials



The historic Cobblestone Farm sits at the center of its own historic district.

Historic Districts in Ann Arbor

Each of Ann Arbor’s locally designated historic districts has its own unique character which is due, in part to local topography, the original period of development and the nature of the district’s early inhabitants. Projects undertaken within each historic district should reflect the historic character that is present in that district.

The following section provides a brief description of each of the city’s historic districts with a map of that district and corresponding photographs. The six historic districts that are completely within the boundaries of downtown Ann Arbor are summarized together.

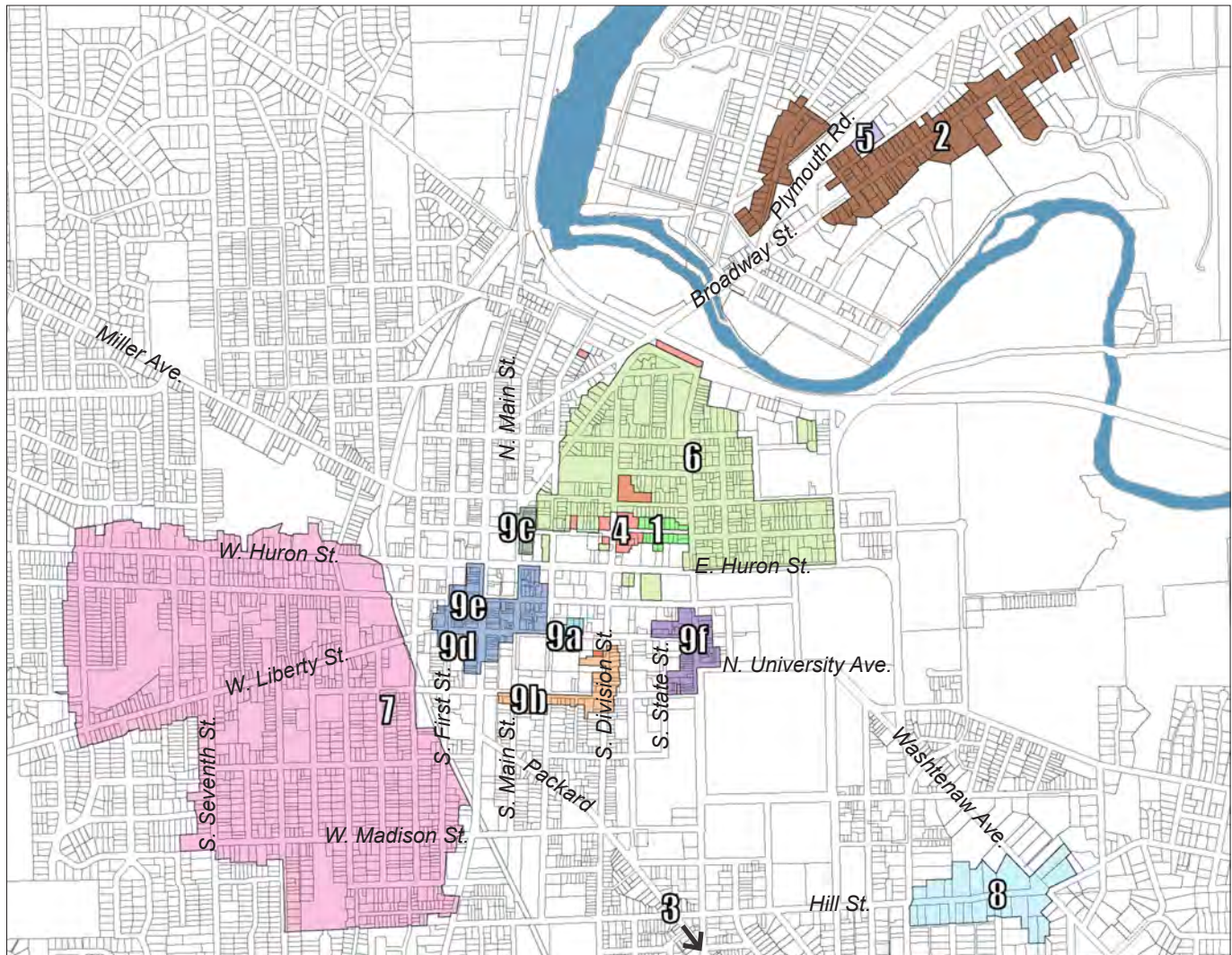

- | | |
|---------------------------------------|--------------------------------|
| 1. Ann Street Historic Block District | 9. Downtown Historic Districts |
| 2. Broadway Historic District | a. East Liberty Block |
| 3. Cobblestone Farm Historic District | b. East William Street |
| 4. Division Street Historic District | c. Fourth Avenue & Ann Street |
| 5. Northern Brewery Historic District | d. Liberty Street |
| 6. Old Fourth Ward Historic District | e. Main Street |
| 7. Old West Side Historic District | f. State Street |
| 8. Washtenaw - Hill Historic District | |



Ann Street Historic Block Historic District

The Ann Street Historic Block Historic District is a one block district between the Division Street Historic District and the Old Fourth Ward Historic District and is a densely spaced, small scale block of nineteenth-century houses. Ann Street was named after Ann Allen, the wife of John Allen, one of the founders of Ann Arbor. This section of Ann Street was extended in 1857 and three of the houses in the district are visible on the 1866 bird's eye map of Ann Arbor. All of the nineteen houses in the district, except one, were constructed before 1900.

Styles in the district include Greek Revival, Italianate, Queen Anne, and Colonial Revival. Ann Arbor's earliest prominent citizens, including doctors, lawyers, businessmen, clergymen, and four of Ann Arbor's mayors built the houses. There is consistency in the massing and form of the houses on the street. They have a relatively small front setback, they are frame structures covered with clapboard or shingles resting on fieldstone foundations, have front porches and are two-stories in height.

Adopted April 16, 1979



The Ann Street Historic Block District occupies most of the block of East Ann Street between North State Street and North Division Street.

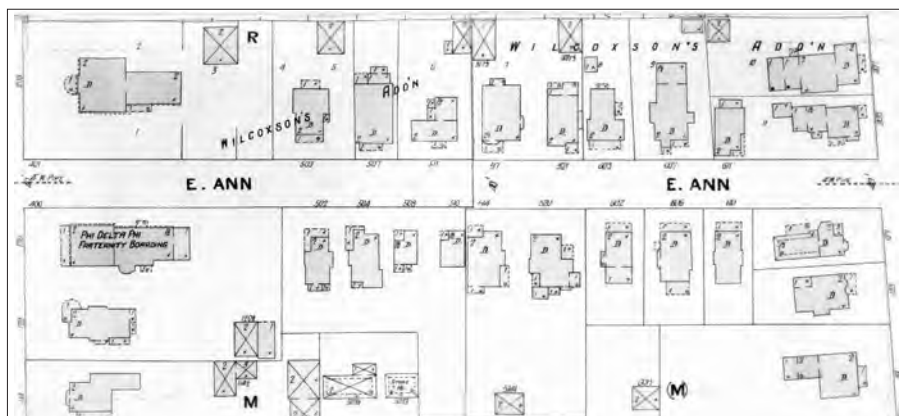

The dense, small scale, context of the Ann Street Historic Block District is illustrated on a 1908 Sanborn Insurance Map.



Many houses in the district such as the residence at 1418 Broadway are smaller than homes typically seen in the historic neighborhoods that are closer to downtown Ann Arbor.



The historic property at 660 Broadway illustrates the somewhat rural character of the Broadway Historic District.



The former Fifth Ward school building on Traver Street is the oldest remaining school building in Ann Arbor.

Broadway Historic District

The Broadway Historic District sits north of downtown Ann Arbor and the Huron River. The first buildings were constructed in 1832 when early settlers from upstate New York arrived to set up mills powered by the Huron River and Traver Creek. Originally settled as a separate community, the area was annexed to the City of Ann Arbor in 1861.

The district is locally significant for its architecture and its role in the early settlement of Ann Arbor, and for the variety of ethnicities and occupations of residents living in the area including African-Americans and German-Americans. In addition to the residences, the district contains the former Fifth Ward school on Traver, the oldest remaining school building in Ann Arbor.

A diverse range of residents felt comfortable living in this area of Ann Arbor because it faced little development pressure. The Charles Cox family built the house at 1210 Broadway in 1894 and lived there until at least 1924. Allen and Elizabeth Morris rented the house at 1404 Broadway from 1900 to 1907 before purchasing their own home elsewhere in the city. Elijah Durham, a cement worker who built some houses on nearby Pontiac Trail, and his wife May, lived at 1525 Broadway from 1913 until about 1925. Ann Arbor's first black policeman, William Blackburn and his wife Clara, lived at 1307 Jones Drive from 1909 until 1919.

The architecture of the district represents the progression of styles seen from early settlement through the 1930s and includes relatively unaltered examples of American styles from the earliest Greek Revival through Italianate and Queen Anne to Colonial Revival and Craftsman. The houses present a picture of what life was like in an early and somewhat rural working class neighborhood of Ann Arbor. Fruit orchards and other agricultural uses were present until the 1940s, and the area remained less dense and had smaller houses than neighborhoods closer to downtown.

Adopted April 21, 2008.



The Broadway Historic District runs along both sides of Broadway Street as well as portions of Plymouth Street and Traver Street to the north of downtown Ann Arbor.



Cobblestone Farm is located in the south-eastern part of Ann Arbor.



The Cobblestone Farm represents one of the last remaining examples of a completely hand-built house in Michigan.



The wooden kitchen area to the rear of the house is also a significant historic resource.

Cobblestone Farm Historic District

The Ticknor-Campbell house is known as the Cobblestone Farm because of the unique construction technique of the cobblestone house on the property. Built for Dr. Benajah Ticknor in 1844 in the Classic Revival style, it is one of the finest of the few cobblestone buildings in Michigan. Together with the wooden kitchen ell in the rear, it forms an unusually fine example of a pioneer Michigan farm dwelling.

The construction of the cobblestone house was probably the work of Stephen Mills, who had learned his trade in western New York state where cobblestone architecture was popular before and after the digging of the Erie Canal. The Classic Revival style of the cobblestone house is reflected in the balance of architectural elements: the use of square “dressed” stone quoins at wall corners, and the use of enclosed columns and sidelights at the entrance. The exterior of the house is symmetrical and features cornice returns and louvered shutters.

The Ticknor-Campbell house was built of hand-hewn oak members joined by mortise and tenon. The finishing courses of cobblestones were veneered onto the rubble-stone inner wall. The house represents one of the last remaining examples of a completely hand-built house, a portion of which is in the rare cobblestone medium. The house was built during a time when Michigan, like the rest of the country, was rapidly becoming dependent on machine technology and shifting to new construction methods.

There has been only one alteration to the exterior of the cobblestone house: during the Booth family tenure (1860-1880), an Italianate style wooden front porch with bracketed columns was added to the front façade, which has since been removed.

Adopted February 1, 1982



The Ticknor-Campbell house is one of the finest of the few cobblestone buildings in Michigan. (c. 1898, Charles Ciccarelli)

Division Street Historic District

The Division Street Historic District is the first local historic district created in Ann Arbor. It is a non-contiguous historic district that includes some of the earliest and most important buildings in Ann Arbor. Together through their architecture and history, they tell the story of Ann Arbor’s early development.

The Bennett (Kempf) and Wilson-Wahr houses are excellent examples of Greek Revival architecture and were the homes of University professors and an early judge. The home of an early brewer is in the Italianate style. The homes of physicians and early newspaper owners are in the district as are high style designs of the DKE Shant designed by William Lebaron Jenney, and the former Michigan Central Depot designed by Spier & Rohns. St. Andrew’s Episcopal Church, the oldest in Ann Arbor, was designed by Gordon W. Lloyd.

Adopted April 16, 1973



The Division Street Historic District includes some of the earliest and most important buildings in Ann Arbor.



121 N. Division Street is an excellent example of Italianate architecture in the Division Street Historic District.



The Wilson-Wahr House at 126 North Division Street is an excellent example of Greek Revival Style Architecture in the Division Street Historic District.



The Division Street Historic District is a non-contiguous historic district that lies primarily north and east of downtown Ann Arbor.

Northern Brewery Historic District

The Northern Brewery Historic District is a district comprised of two structures, a Brewery Building and a Foundry Building located at 1327 Jones Drive. Constructed in 1886 by Herman Hardinghaus, beer was brewed at this location until 1908, when the building was converted to an icehouse run by Ernest Rehberg. The Ann Arbor Foundry, owned by Charles Baker and Tom Cook, operated on the property from 1922 to 1972. The buildings were completely rehabilitated using federal historic tax credits in 1976.

Adopted December 18, 1978



The Northern Brewery Historic District is located northeast of the Huron River, just off of Broadway Street.



The buildings that comprise the Northern Brewery Historic District were completely rehabilitated in 1976 using federal historic tax credits.



The Old Fourth Ward Historic District is one of the oldest residential neighborhoods in Ann Arbor.



A section of the Old Fourth Ward Historic District sits within the boundaries of downtown Ann Arbor.

Old Fourth Ward Historic District

The Old Fourth Ward Historic District is one of the oldest residential enclaves in Ann Arbor. The city’s Fourth Ward from 1851 until 1955, the neighborhood was home to the city’s early bankers, lawyers, judges, doctors, merchants, and city officials – including seven mayors.

The neighborhood was a popular boarding house area for professors and students, many of whom achieved national as well as local prominence in the course of their careers. Many of Ann Arbor’s best known educators lived in the district including University of Michigan President Henry Frieze, Ann Arbor High School principals Albert and Judson Pattengill, the first director of the public school system Edwin Lawrence, and many popular teachers throughout the years. The district also housed some of the city’s early schools. Community High School, built in 1922 as Jones School, sits on the site of the original Fourth Ward School.

There are over 400 resources in the district, nearly one-third of which were constructed before 1900. Most of the remaining structures were built soon after 1900 and represent many of the architectural styles including Greek Revival, Gothic and Italianate, Queen Anne, Shingle, and the revival styles of the early 1900s.

The district contains several churches, including the First Unitarian Church, an excellent example of the Richardson Romanesque style. Many of the city’s “firsts” are located in the district including the first synagogue, the first home for the elderly, the oldest surviving apartment house, the second oldest surviving schoolhouse, and the first university cooperative housing constructed in the United States. Other unique buildings in the district include a firehouse, Harris Hall, and the former Armory.

Adopted August 15, 1983



Nearly one-third of the homes in the Old Fourth Ward Historic District were built prior to 1900 including this Italianate home at 311 East Ann Street.



The Old Fourth Ward Historic District is located primarily to the northeast of downtown Ann Arbor. A section of the district is located within the boundaries of downtown and several sections of the district are non-contiguous.



The wide porch and modest scale of the home at 308 West Huron Street is typical of the Old West Side Historic District.



Many homes in the Old West Side Historic District have front facing gable roof forms.

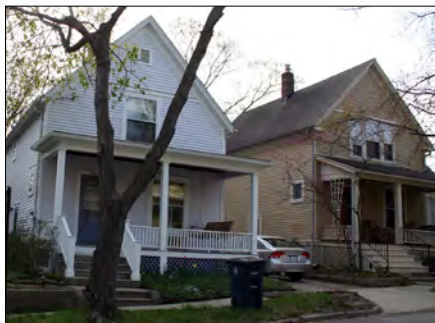

Many houses in the Old West Side Historic District are one-and-a-half to two stories tall.

Old West Side Historic District

The Old West Side Historic District, located to the south and west of downtown, is a neighborhood primarily consisting of houses constructed in the 19th century. The southern half of the district was platted between 1848 and 1861 by William S. Maynard. The northern half was platted later, and Murray and Mulholland Streets were platted in the 1910s. The neighborhood historically had a strong German heritage, with the German language being used in churches, schools, and newspapers. Residents were shopkeepers or workers in the nearby industries such as the Michigan Furniture Factory, the Michigan Union Brewery, or the vinegar works next to the Ann Arbor Railroad on the east border of the district.

While there are a few larger houses and commercial buildings in the district, the majority of the buildings are modest, gable-fronted, clapboard-sided houses, one-and-one-half to two-stories tall, with wide front porches and generous side yards. Nearly every architectural style from the 19th and early 20th centuries exists in the district, including examples of Italianate, Queen Anne, Colonial Revival, Craftsman, and Bungalow styles. Modern buildings, primarily three-story, brick apartment buildings, were built east of Third and north of Jefferson, closer to downtown.

Adopted April 6, 1978



With its wide front porch and gable front, the modestly scaled Craftsman style home at 116 Chapin is typical of the Old West Side Historic District.

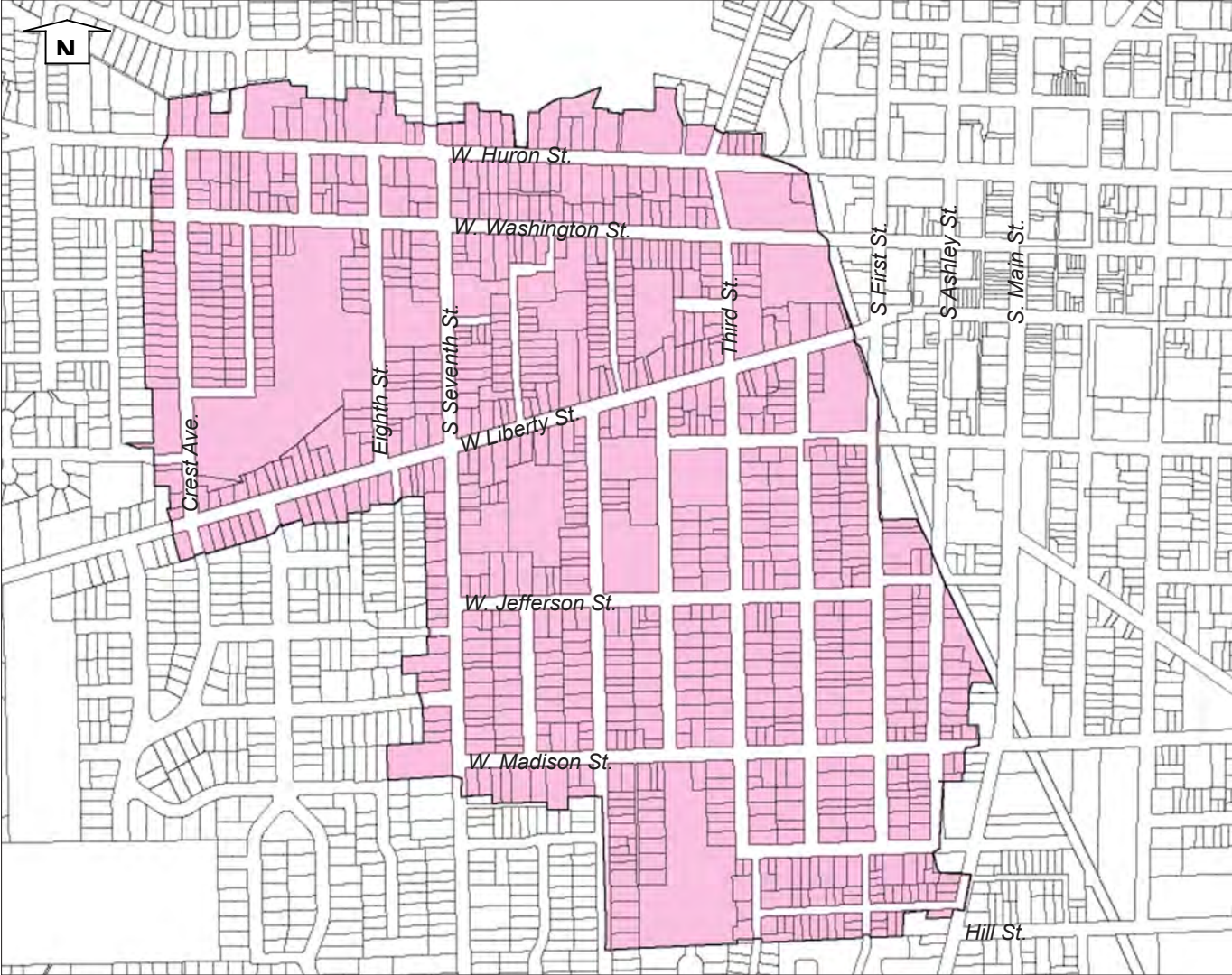

The Old West Side Historic District is located to the south and west of downtown Ann Arbor. A portion of the district lies within the downtown boundaries on the west side of the railroad tracks.



Numerous old growth trees grace the Washtenaw - Hill Historic District and are important to the setting and character of the area.



A number of sororities and fraternities occupy historic structures in the Washtenaw - Hill Historic District.

Washtenaw - Hill Historic District

The Washtenaw - Hill Historic District is comprised of the 1300, 1400, and 1500 blocks of Hill Street and one corner of Washtenaw, totaling twenty one parcels. The district is located to the south and east of the University of Michigan central campus and has strong university associations, with the majority of the houses having been built for faculty. This reflects the huge surge in growth of the university between 1890 and 1930 when the number of faculty went from 35 in 1871 to over 3,000 in 1929.

Four houses have noted architects. 1410 and 1416 Hill Street were designed by Irving Pond, and 1331 Hill and 1555 Washtenaw were designed by Albert Kahn. Some of the Tudor Revival, Colonial Revival, and Craftsman style houses have been converted to student housing. The tradition of sororities and fraternities being located in this area began in 1903 and became prevalent in the 1920s, and many of the organizations had the houses built.

Numerous old growth trees grace the district and are important to the setting and character of the area.

Adopted April 10, 1980

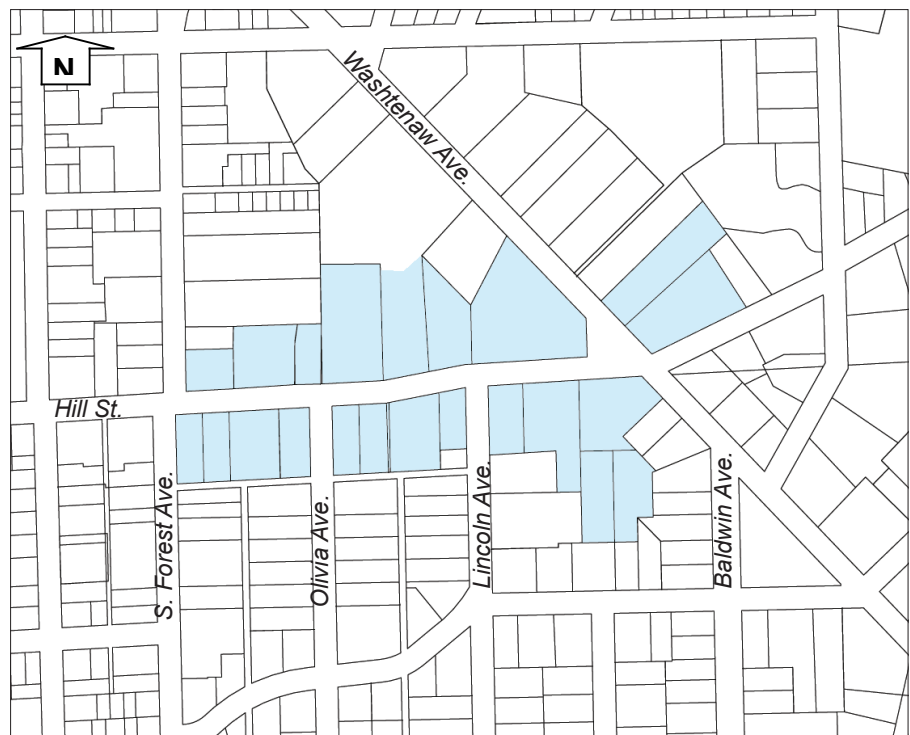

The Washtenaw - Hill Historic District is located south and east of the University of Michigan central campus.

Downtown Historic Districts

As the traditional civic, economic and cultural heart of the community, downtown Ann Arbor is rich in historic resources. Six historic districts lie completely within the downtown boundaries. They are:

- East Liberty Block Historic District (Adopted March 16, 1992)
- East William Street Historic District (Adopted December 18, 1989)
- Fourth Avenue/Ann Street Historic District (Adopted December 18, 1989)
- Liberty Street Historic District (Adopted March 10, 1975)
- Main Street Historic District (Adopted December 18, 1989)
- State Street Historic District (Adopted March 16, 1992)

Portions of three other historic districts, the Division Street Historic District, the Old Fourth Ward Historic District and the Old West Side Historic District, lie within the boundaries of downtown. They are described separately within this chapter.

The first businesses in Ann Arbor were opened soon after John Allen and Elisha Walker Rumsey established the town site in 1824. The central business district developed along Main Street and around the county courthouse square. By 1838 Ann Arbor boasted, "...a court-house, a jail, a bank, two banking associations, four churches, one each of Presbyterian, Baptist, Episcopal, and Universalist, two printing presses which issue two weekly newspapers, a bookstore, two druggists, a flouring mill with six run of stone, a sawmill, woolen factory, carding machine, iron foundry, and extensive plow manufactory, two tanneries, seventeen dry-goods stores, eleven lawyers and nine physicians," as described by Burke A. Hinsdale in his book *History of the University of Michigan*, published in 1906. Historic photographs show that most of the earliest retail businesses occupied wood frame structures.

A post-Civil War building boom propelled a transformation of the downtown from a collection of insubstantial buildings to a stately array of "commercial palaces," a mode popular for retail business buildings since its introduction in New York in the 1840s. Two- and three-story masonry structures with richly ornamented façades offered patrons an elegant atmosphere in which to browse – an atmosphere calculated to stimulate the desire to purchase. By 1878, when a railroad link with Toledo was finally established, Ann Arbor had become one of the most thriving business centers west of Detroit.

Beginning in the 1870s, a second business area developed on State Street adjacent to the expanding University of Michigan. In August of 1916 the *Daily Times News* reported numerous changes along State Street, so many, in fact, that the reporter doubted that returning students would recognize the area. In this area the majority of the commercial buildings are two-story and from the early twentieth century. One particularly impressive addition was the Nickels Arcade, a unique type of commercial development in Ann Arbor.



The Main Street Historic District includes many narrow commercial buildings with tall first floor storefronts such as the Italianate style building at 122 West Washington.



Most of the primarily two-story commercial buildings in the State Street Historic District were built in the 20th Century such as the Art Deco style State Theater at 231 South State Street.



The East Liberty Block Historic District is located near the center of downtown Ann Arbor, just to the east of the Main Street Historic District.



The East Liberty Street Historic District includes a number of historic residential structures that have been converted to commercial use.

As both the Main Street and State Street districts expanded a commercial corridor grew up along Liberty Street that functioned as a link between the two. While the residential character of the neighborhood lying between the two districts was never entirely erased, significant commercial developments occurred along East Liberty in the 1910s, 1920s and 1930s. The Zwerdling Block, the Darling Block and the Michigan Theater evidence this era of development in the city's business history.

The styles of buildings within the six downtown historic districts cover the range of popular architectural designs from the 1860s through the 1940s and include Italianate, Queen Anne, Romanesque Revival, 20th Century Commercial Style, Beaux Arts, and Art Deco.



The East William Street Historic District is located along East William Street and South Division Street on the south side of downtown Ann Arbor.



The East William Street Historic District includes both historic commercial and converted historic residential structures.



The Fourth Avenue/Ann Street Historic District is located in the northern part of downtown Ann Arbor.



Most historic buildings in the Fourth Avenue/Ann Street Historic District are commercial.



The 4th Avenue/Ann Street Historic District includes a variety of historic architectural styles.



Building scale is highly varied in the Main Street Historic District.

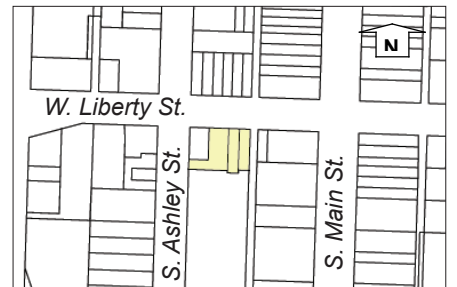

The Liberty Street Historic District is a small historic district located along the southwestern boundary of the Main Street Historic District.



The Liberty Street Historic District includes Romanesque and Italianate style commercial buildings.



The Main Street Historic District sits at the center of downtown Ann Arbor.



Most historic structures in the Main Street Historic District have richly ornamented masonry façades that are two to three stories in height. However, some notable historic buildings in the district are considerably taller.



The State Street Historic District is located on the eastern side of downtown Ann Arbor adjacent to the University of Michigan central campus.



The State Street Historic District is an important commercial center for students at the University of Michigan.

The Nickels Arcade is a unique feature of the State Street Historic District.

CHAPTER 2: THE SECRETARY OF THE INTERIOR'S STANDARDS FOR REHABILITATION

The United States Secretary of the Interior publishes a set of standards for the treatment of historic properties. This chapter presents the Secretary of the Interior's Standards for Rehabilitation. These standards inform many preservation programs and provide a basis for the more detailed design guidelines presented in Chapters 3-7 of this document.

In accordance with state and local law, the Ann Arbor Historic District Commission is required to use The Secretary of the Interior's Standards for Rehabilitation and Guidelines for Rehabilitating Historic Buildings. The ten standards are listed on the next page. The illustrated rehabilitation guidelines provided by the Secretary of the Interior also apply but are too lengthy to publish within this document. The guidelines may be viewed on the National Park Service web site as described in the "For More Information" box on the right side of this page.

FOR MORE INFORMATION

Additional information is available from the Historic District Commission and the National Park Service.

Commission. Copies of the complete Secretary of the Interior's Standards for Rehabilitation are available from the Historic District Commission offices at City Hall.

Park Service. More information is also available on the National Park Service web site at: <http://www.nps.gov/tps/standards/rehabilitation.htm>



The Secretary of the Interior's Standards for Rehabilitation instructs that each property be recognized as a physical record of its time, place and use.





Deteriorated features should be repaired rather than replaced.

Text of the Secretary of the Interior's Standards for Rehabilitation

REHABILITATION IS DEFINED AS the act or process of making possible a compatible use for a property through repair, alterations, and additions while preserving those portions or features which convey its historical, cultural, or architectural values.

1. A property will be used as it was historically or be given a new use that requires minimal change to its distinctive materials, features, spaces, and spatial relationships.
2. The historic character of a property will be retained and preserved. The removal of distinctive materials or alteration of features, spaces, and spatial relationships that characterize a property will be avoided.
3. Each property will be recognized as a physical record of its time, place, and use. Changes that create a false sense of historical development, such as adding conjectural features or elements from other historic properties, will not be undertaken.
4. Changes to a property that have acquired historic significance in their own right will be retained and preserved.
5. Distinctive materials, features, finishes, and construction techniques or examples of craftsmanship that characterize a property will be preserved.
6. Deteriorated historic features will be repaired rather than replaced. Where the severity of deterioration requires replacement of a distinctive feature, the new feature will match the old in design, color, texture, and, where possible, materials. Replacement of missing features will be substantiated by documentary and physical evidence.
7. Chemical or physical treatments, if appropriate, will be undertaken using the gentlest means possible. Treatments that cause damage to historic materials will not be used.
8. Archeological resources will be protected and preserved in place. If such resources must be disturbed, mitigation measures will be undertaken.
9. New additions, exterior alterations, or related new construction will not destroy historic materials, features, and spatial relationships that characterize the property. The new work will be differentiated from the old and will be compatible with the historic materials, features, size, scale and proportion, and massing to protect the integrity of the property and its environment.
10. New additions and adjacent or related new construction will be undertaken in such a manner that, if removed in the future, the essential form and integrity of the historic property and its environment would be unimpaired.

CHAPTER 3: DESIGN GUIDELINES FOR ALL HISTORIC PROPERTIES

IN THIS CHAPTER	
Additions to Historic Structures	3-1
Historic Building Elements	3-5
Historic Site Features	3-16

This chapter presents general design policies and guidelines for the maintenance, rehabilitation and expansion of existing commercial and residential historic resources. The more detailed design guidelines in Chapter 4: Design Guidelines for Historic Residential Properties or Chapter 5: Design Guidelines for Historic Commercial Properties are also applicable, depending on the type of project.

Additions to Historic Structures

New additions to historic buildings are appropriate as long as they do not destroy historic features, materials, and spatial relationships of the original building, site, and the historic district. New additions should be differentiated from the original building and constructed so that they can be removed in the future without damage to the historic resource.

A new addition should never compromise the integrity of the original structure or site either directly through destruction of historic features and materials or indirectly through the location, size, height, scale, design, and materials of the addition. Additions at the rear or to the top of flat roofed commercial buildings should be designed not to be visible from the main street.



Additions to historic residential structures should be inconspicuous and should not compromise the historic integrity of the original structure.



Locate and design a new addition so that significant site features, including mature trees, are not lost or damaged.

Guidelines for All Additions

The following general guidelines should be followed when planning an addition to a historic commercial or residential structure. Additional consideration specific to residential or commercial additions are described in the next section. The design guidelines for building elements later in this chapter should be used when working with existing additions that may be historic in their own right.

Appropriate

- Locating a required addition on the least character-defining elevation and keeping it subordinate in volume to the historic building.
- Placing a new addition on the rear or inconspicuous elevations and limiting the size and scale in relationship to the historic property.
- Locating and designing a new addition so that significant site features, including mature trees and landmark status trees, are not lost or damaged.
- Designing a new addition in a manner that makes clear what is historic and what is new.
- Limiting the size and scale of the addition in relationship to the historic building so that it does not diminish or visually overpower the building or the district. The addition's footprint should not exceed half of the original building's footprint, or half of the original building's total floor area.
- Designing the addition so it is compatible in terms of massing, materials, relationship of solids to voids, and proportion of openings.
- Placing functions and services required for the new use in non-character-defining interior spaces rather than constructing a new addition.

Not Appropriate

- Attaching an addition so that the character-defining features of the property are obscured, damaged or destroyed.
- Designing a new addition so that the size and scale in relation to the historic property are out of proportion.
- Designing an addition that requires the removal of significant building elements or site features.
- Constructing an addition that significantly changes the proportion of built mass to open space on the individual site.
- Designing an addition that turns a secondary façade into a primary façade.
- Designing an addition to appear older or the same age as the original building.

Additions to Historic Residential Structures

The following additional guidelines should be followed when planning an addition to a historic residential structure.

Appropriate

- Locating an addition within a new detached accessory structure located to the rear of a primary historic structure.
- Separating a larger addition from the primary historic structure and linking it with a smaller connecting structure.
- Placing new walls in a different plane from the historic structure in a subordinate position to the historic fabric.

Not Appropriate

- Designing an addition that overpowers or dramatically alters the original building through size or height.
- Designing an addition that adds a full floor directly above the front of a historic house.

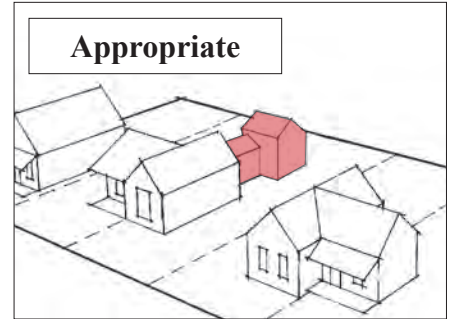

Separating a larger addition from the primary structure and linking it with a smaller connecting structure may help the overall perceived mass of an addition.

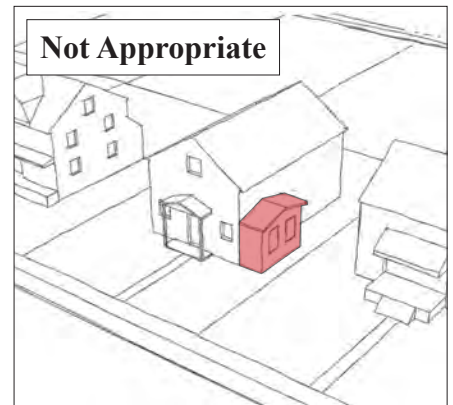

It is generally not appropriate to attach an addition that is on or near the primary façade of a historic residential structure.

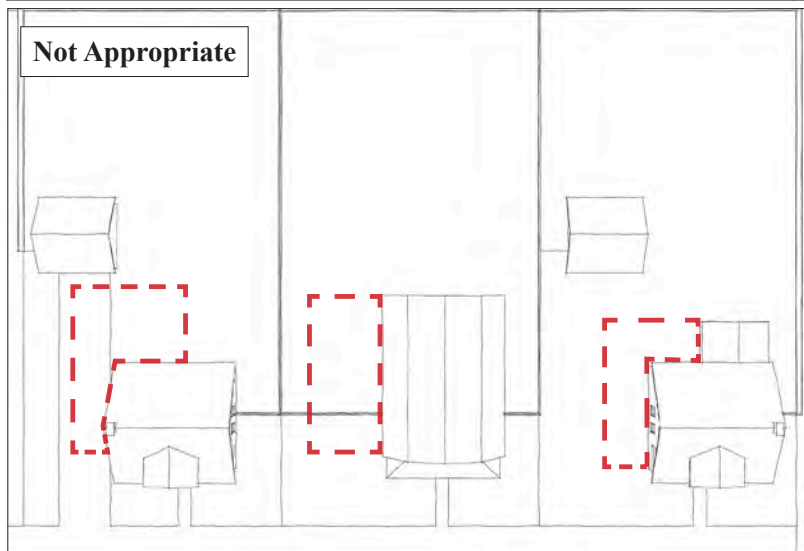
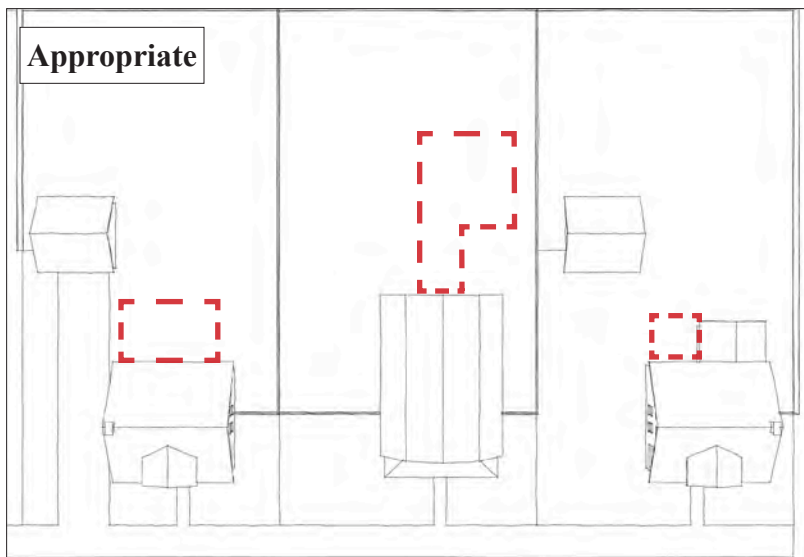

Place a new addition in a non character-defining or inconspicuous location and limit its size and scale in relationship to the historic property.



Design a new addition in a manner that makes clear what is historic and what is new.

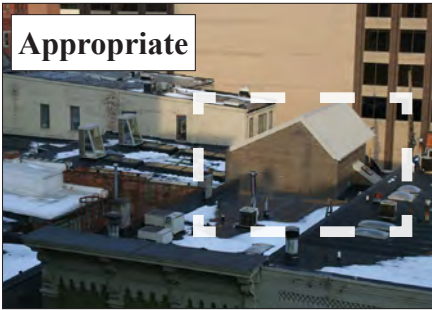

Rooftop additions to commercial buildings should be as inconspicuous as possible when viewed from the street.

Additions to Historic Commercial Structures

The following additional guidelines should be followed when planning an addition to a historic commercial structure.

Appropriate

- Placing additions such as balconies on non character-defining elevations and limiting the number, size and scale in relationship to the historic building.
- When required, designing additional stories that are set back from the front and side wall planes and are as inconspicuous as possible when viewed from the street.
- Locating a rooftop addition to be inconspicuous when viewed from the street.

Not Appropriate

- Designing an addition that overpowers or dramatically alters the original building through size, height, or materials.
- Designing an addition that adds a full floor at the streetwall of a historic commercial building without stepping back.

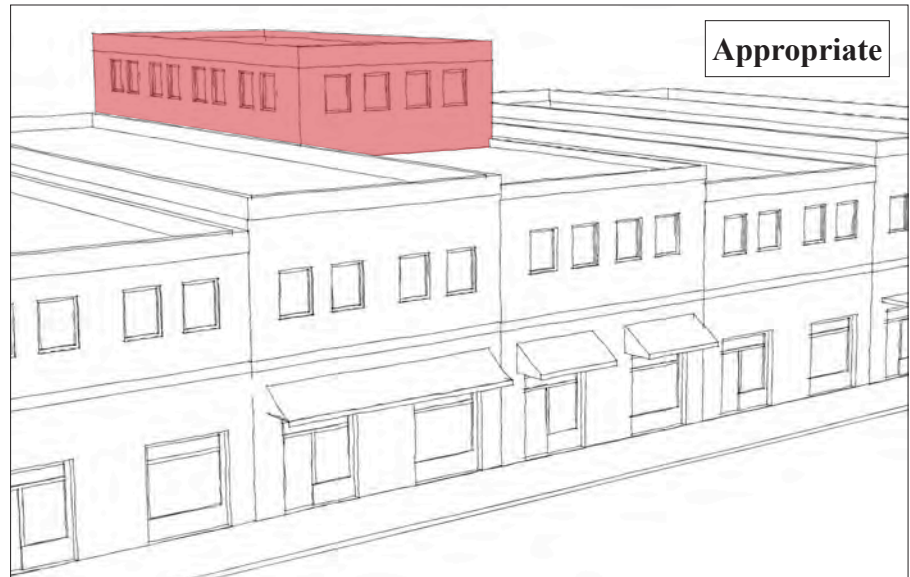

Locate a rooftop addition to be as inconspicuous as possible when viewed from the street.

Historic Building Elements

Historic building elements seen on both commercial and residential historic properties include windows, materials, roofs, landscape features and lighting. This section provides general guidelines for historic building elements on both commercial and residential properties. More specific guidelines that are unique to commercial or residential settings are provided in Chapter 4: Design Guidelines for Historic Residential Properties or Chapter 5: Design Guidelines for Historic Commercial Properties.

Windows

The various arrangements of windows, the sizes and proportion of openings, and the decorative elements associated with them are used to achieve and enhance the architectural style of the building. Windows are an important design element of historic buildings and every effort should be made to preserve or duplicate their unique features. Peeling paint, air infiltration, sticking sash and broken panes are all repairable conditions and do not necessitate replacement. Imperfections in historic glass and the depth and profile of muntins all give historic windows a distinct visual quality not replicated with modern window replacements.

The Historic District Commission will assist homeowners in evaluating the windows of a historic building and will furnish a list of local firms/individuals competent in window repair and sash replacement. Such an evaluation is required before proceeding with major repairs or, if necessary, replacement of deteriorated windows.

Historic Window Types and Parts. When working with historic windows it is helpful to be familiar with window types and parts. The following pages include a Historic Window Types and Historic Window Parts diagrams. These illustrations will assist with interpretation of the design guidelines for windows. A Window Element Measurements diagram is also included in the appendix to the Historic District Design Guidelines.

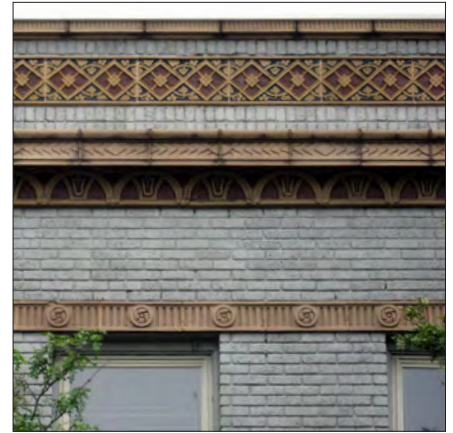

Historic building elements include masonry walls and architectural details on both historic commercial and residential buildings.



Windows are an important design element of historic buildings and every effort should be made to preserve or duplicate their unique features.

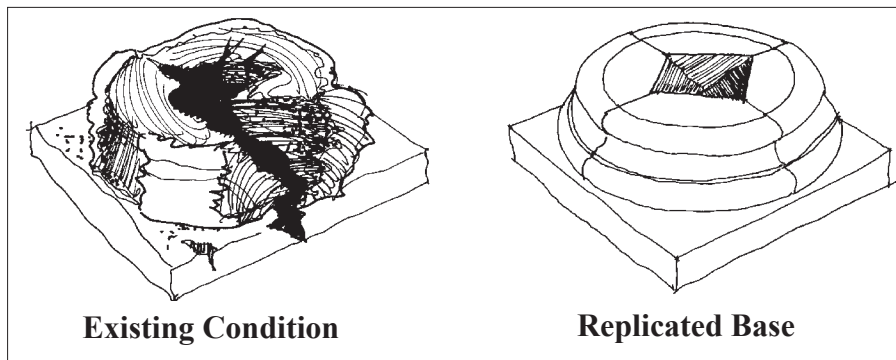

Whenever possible, historic building elements should be repaired and rehabilitated rather than replaced. If a historic building element is deteriorated beyond repair, however, it may be appropriate to replicate the original feature.

Historic Window Types

The following are four common types of windows seen frequently in residential and commercial buildings.



Double-Hung: A window with two sashes, each movable by means of a sash cord and weights, or some other mechanism. Double hung windows are the most popular.

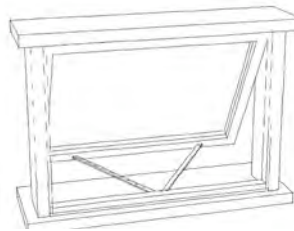

Awning: A window that is hinged at the top and swings outward. Awning windows are often used for ventilation under large, fixed-pane windows in contemporary homes. They keep out rain when open, as long as the wind is not blowing hard.

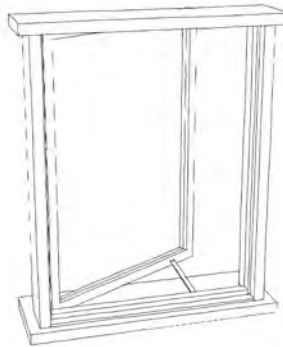

Casement: A single window sash that opens on hinges fixed to its vertical edge. The casement window's full-height opening provides excellent ventilation. Casements, especially wooden ones, can suffer damage if left open in the rain.

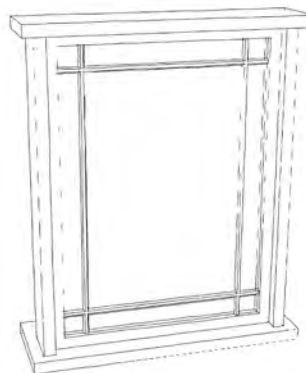

Fixed: A fixed frame window (or part thereof) that does not open. Fixed windows have a sash that is permanently affixed to the frame. They are often flanked by double-hung or casement, or set above or below an awning or hopper. They come in a variety of shapes, including round, half-round, diamond, and trapezoid (to echo gable-end rafter pitches).

Historic Window Parts

The numbered historic window parts glossary terms are keyed to the numbers on the diagram to the right. Familiarity with historic window parts will assist in planning for maintenance and rehabilitation of historic windows.

1. Apron: Non-moving, interior portion of the window below the sill.

2. Casing: The finished, visible framework around a door or window.

Drip Cap (not pictured): A usually small, horizontal molding strip located above a door or window casing; designed to shed water, causing it to drip beyond the outside of the frame.

3. Frame: The fixed, outer portion of the window that holds the sash.

4. Jamb: The vertical member at each side of the window frame.

5. Lights: The glass within the window; can refer to the number of divided areas of glass.

Mullion (not pictured): A vertical member between window panels set in a series.

6. Muntin: A secondary framing member that holds the panes of glass within a window or window wall.

7. Pane: A single piece of window glass.

8. Rail: Horizontal members of the sash.

9. Sash: The framework into which panes are set.

10. Sill: The exterior horizontal portion at the bottom of a window. The sill keeps the jamb boards lined up properly and is angled to drain water off the surface. The sill should be watched for water damage and rot.

11. Stile: Any vertical member of a sash.

12. Stool: The interior casing or molded piece running along the base of a window and contacting the bottom rail on the inside of a building. Also known as the interior sill.

13. Stop: The removable vertical strip against which a window sash rests.

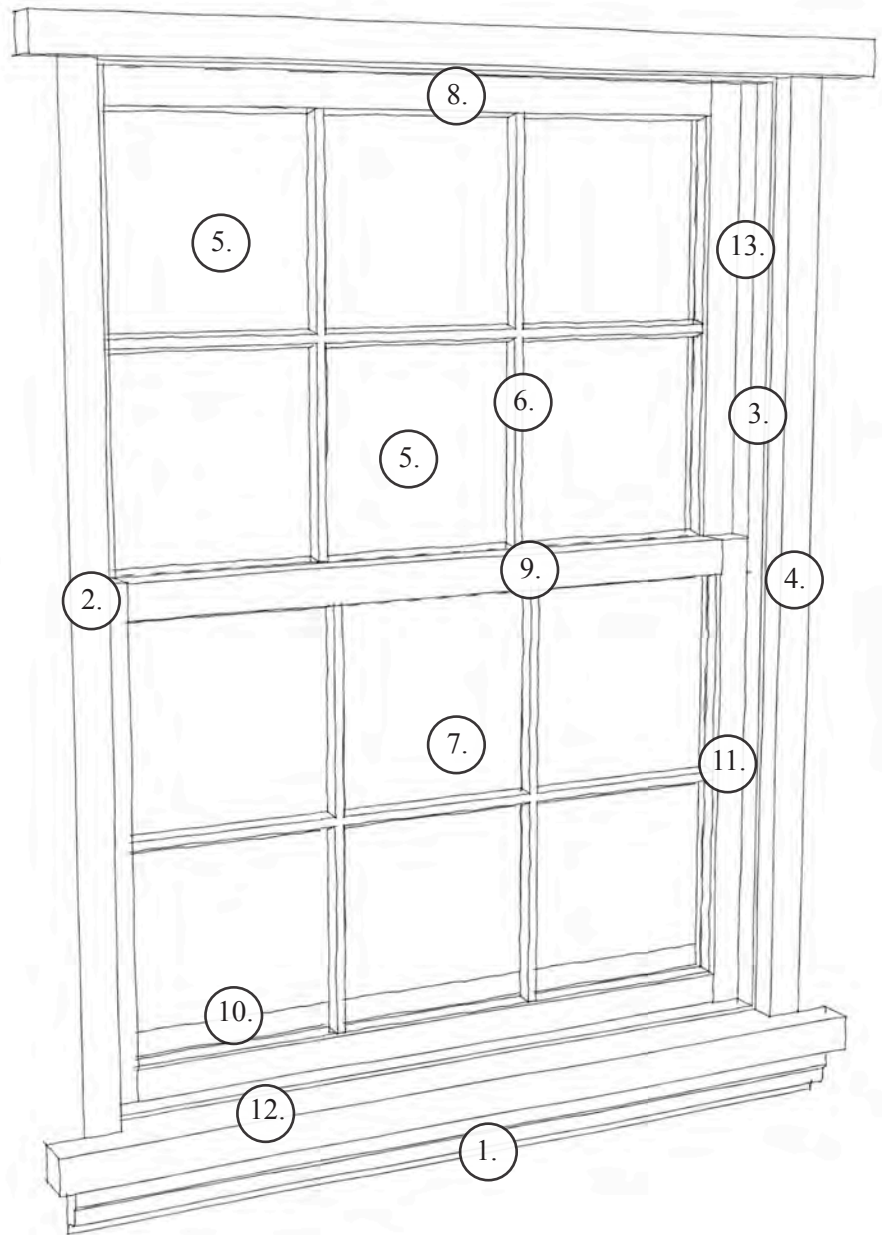



Historic windows should be preserved and maintained. The Historic District Commission will not consider approval of historic window replacement unless window parts are deteriorated beyond repair.

Replacement Guidelines.

- **Windows in good condition will remain.** Normal maintenance will include cleaning, sash cord replacement, limited paint removal, re-caulking where necessary, and new paint to make windows fully operable. Weather stripping and storm windows may be added.
- **Windows in somewhat good condition will receive repair,** such as new wood or epoxy laid into sills, jamb, or sash. Deteriorated parts, such as sash locks and cords, will be replaced.
- **Seriously deteriorated components that cannot be repaired will be replaced** with a sash of like material that meets the criteria below. Insulated glass is permitted in sash replacement.
- **Windows and components deteriorated beyond repair** (deep rot, missing parts, major perimeter gaps) are the only elements the the Historic District Commission will consider for replacement.

Replacement Criteria. Only if the components are deteriorated beyond repair (deep rot, missing parts, major perimeter gaps) will the Historic District Commission entertain the option of window replacement. Applicants should be prepared to bring a sample of the proposed window as requested. The Historic District Commission requires that a new replacement window meet all of the following criteria:

- The unit functions as the original (double-hung, casement, etc.).
- The glass size remains within 90% of the original in all directions.
- The distance between the exterior sash surface and the exterior glass surface (inset) is within 1/8" of the original.
- The number and location of muntins matches the original. The distance from glass surface to exterior surface of muntin, rail, and stile is at least 3/8". The viewable profile dimensions of the exterior rails and stiles are within 1/4" of the original.
- The distance from sash face to back of casing is within 1/8" of the original dimensions, but not less than 3/8" total.
- The sill is similar in pitch to the original, extend to the outer edge of casing, and have a thickness within 1/8" of the original.
- The casing (including drip cap, if applicable) thickness matches original.
- The casing (including drip cap, if applicable) width is within 1/8" of the original.

The Window Elements Measurements diagram included in the appendix to this Historic District Design Guidelines document may assist with the measurement of window elements for repair. Contact the Historic District Commission for a resource list of individuals and companies who may be equipped to aid in your window evaluation/repair.

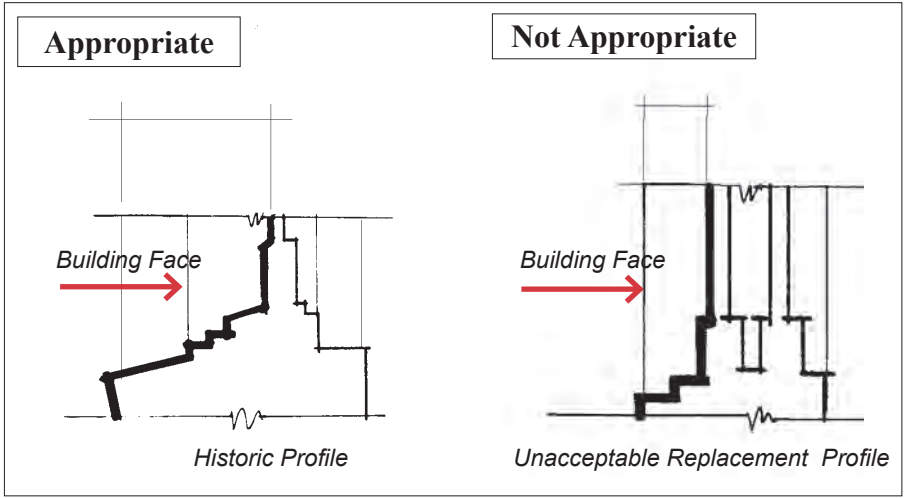

When replacing a historic window, match the profile of the sash and its components as closely as possible to that of the original window.

Original Historic Window**Not Appropriate****Not Appropriate**

It is not appropriate to radically change or block an historic window that is important in defining the overall historic character of the property.

Design Guidelines for Windows. The following guidelines should be followed when repairing, cleaning, rehabilitating or replacing a historic window on either a commercial or residential structure.

Appropriate

- Retaining and maintaining windows in good condition. Normal maintenance will include cleaning, sash cord replacement, limited paint removal, re-caulking where necessary, and new paint to make windows fully operable.
- Adding weather stripping and painted wood or aluminum storm/screen windows that fit the opening size to improve energy efficiency.
- Repairing windows in somewhat good condition, by installing some new wood pieces or laying epoxy into sills, jamb, or sash. Deteriorated parts, such as stops and sash cords, should be replaced.
- Replacing seriously deteriorated components that cannot be repaired with like material, identical layout, muntin size, glass area, and stile size to the original. Insulated glass is permitted when sash replacement is permitted using interior and exterior muntins with a spacer bar that replicates the original window. (Relevant criteria for window replacement apply.)
- If a window is completely missing, replacing it with a new window based on accurate documentation of the original or a new design compatible with the original opening and the historic character of the building. Materials other than wood will be reviewed by the Commission on a case-by-case basis.
- Replacing shutters that are missing or deteriorated beyond repair with shutters that are based on historic and pictorial evidence.

Not Appropriate

- Failing to maintain and repair existing windows.
- Replacing an entire window that is not deteriorated beyond repair.
- Removing or radically changing a window that is important in defining the overall historic character of the property.
- Installing a smaller replacement window within the frame of the historic window.
- Changing the number, location, and size or glazing pattern of window by cutting new openings, blocking-in, and installing replacement sash which does not fit the historic opening.
- Using tinted, reflective, or opaque glass.
- Installing an exterior storm/screen window that is an inappropriate size and that does not blend with the existing window.
- Using glass block to fill in openings.
- Wrapping exterior wood window trim in aluminum or vinyl.
- Installing decorative trim or shutters when a property never had any.
- Installing security bars on the exterior or interior of windows.



It is appropriate to preserve and maintain wood siding, trim and architectural details.

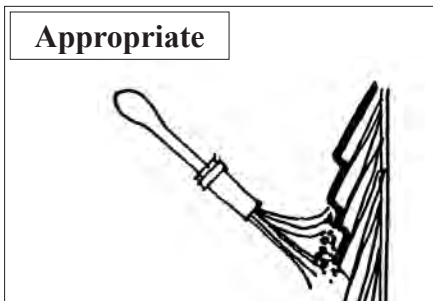

Preserve and maintain wood siding, shingles, trim and architectural features by protecting surfaces with paint or stain.

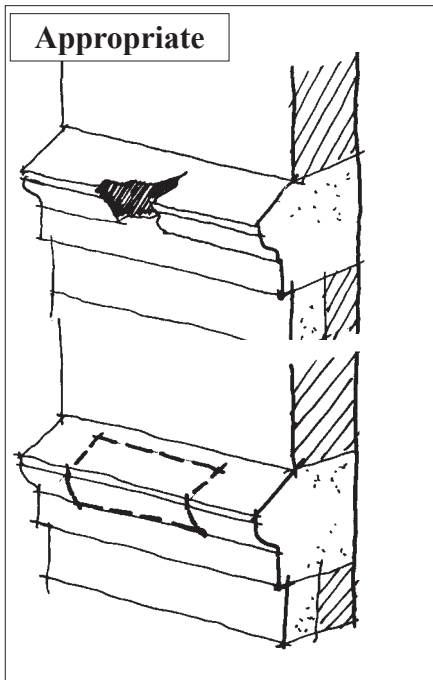

Repair and maintain both wood and masonry by patching or piecing in new elements that match the original.

Wood Siding, Trim and Architectural Details

Wood is historically the most commonly used building material. It was used in framing, exterior cladding, windows and doors, and ornamental detailing. Wooden features and surfaces on a building should be maintained and repaired to retain the original character of the structure. Repair or replacement of deteriorated wood may involve selective replacement of portions in kind through splicing or it may involve the application of an epoxy wood consolidant to stabilize the deteriorated portion in place.

Design Guidelines for Wood. The following guidelines should be followed when repairing, cleaning, rehabilitating or replacing historic wood siding, trim and architectural details on both commercial and residential structures.

Appropriate

- Preserving and maintaining wood siding, shingles, trim, and architectural features by protecting surfaces with paint or stain.
- Repairing wood siding, shingles, trim, and architectural features by using recognized preservation methods for patching, consolidating, splicing and reinforcing in order to exactly match the existing historic material appearance.
- Replacing wood siding, shingles, trim, and architectural features that are deteriorated beyond repair with components that exactly match the original in dimension, detail, and texture.
- Removing non-original substitute siding and trim and restoring the original wood siding, trim and architectural features.
- Replacing missing features with elements based on documentation of the original feature or with a new design that is compatible in scale, size, material, and texture with the historic building and district.
- Removing damaged or deteriorated paint to the next sound layer using the gentlest means possible (hand-scraping and hand-sanding), then repainting.

Not Appropriate

- Using substitute materials to cover or replace wood siding, shingles, trim, and architectural features.
- Introducing new elements that were not part of the historic building and for which there is no physical, pictorial, or documentary evidence.
- Stripping surfaces to bare wood and applying a clear stain or finish to create a “natural” wood surface that historically was painted.
- Cleaning or stripping wood surfaces with destructive methods such as blasting, power washing, and propane or butane torches.

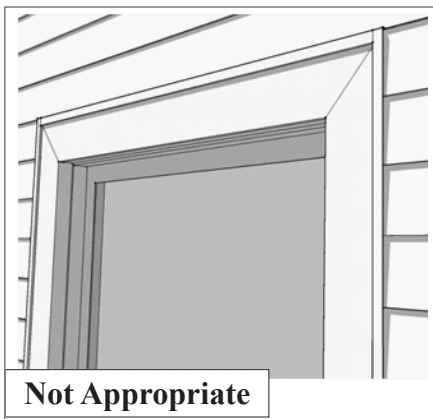
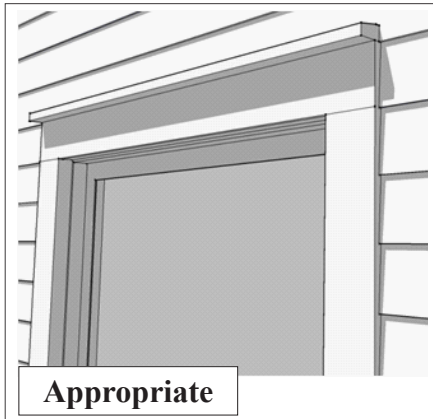

In the original siding detail shown on top, the face of the window casing trim sits in front of the leading edge of the siding. In the example on the bottom, the synthetic siding “J-trim” protrudes in front of the window casing. Additionally, the drip cap above the window has been removed to facilitate ease of installation of the synthetic siding. This loss of detail is one of the primary reasons for discouraging the installation of synthetic siding.

Synthetic Replacement Siding

The Ann Arbor Historic District Commission (HDC) has determined that the installation of vinyl or aluminum replacement siding introduces a potential risk to the city’s historic resources. In the past, poorly considered, inappropriately detailed replacement siding projects have damaged or destroyed character-defining features of buildings and their environments. Given that historic resources should be retained and repaired when feasible, the possibility that materials might be covered up or damaged during the installation of synthetic siding has led the HDC to discourage the use of synthetic siding. The HDC will consider the installation of synthetic replacement siding on historic resources in only the following specific instances:

Replacement of the historic material will only be considered when retention and repair of the existing material is not feasible. Under such circumstances, the new material must closely match the size, scale and details of the existing material. Additionally, character-defining features of the resource may not be removed, damaged or covered when installing the new synthetic material.

Design Guidelines for Synthetic Replacement Siding. The following guidelines should be followed when replacing existing siding with new synthetic replacement siding on both commercial and residential structures.

Appropriate

- Identifying, retaining, and preserving wood features that are important in defining the overall historic character of the building such as siding, cornices, brackets, window architraves, and doorway pediments; and their paints, finishes, and colors.
- Performing an overall inspection of any existing damage to determine and eliminate the source of the damage before undertaking the installation of synthetic siding.
- Matching the replacement siding to the existing siding as closely as possible. Exposure to the weather should be within 1” of the existing siding and in any case, be no more than 5”.
- Replicating special details, such as beaded edges, drop lap profile or fish scales.
- Using replacement siding that exhibits a smooth texture.

Not Appropriate

- Using vinyl siding to replace wood or cementitious siding.
- Obscuring character-defining trim details, such as corners, window and door hoods, and ornamental shingles.
- Removing any character-defining trim details.
- Obscuring historic window and door trim with metal or other material.
- Using replacement siding that has a textured finish, such as embossed wood grain.

Masonry Walls, Trim and Foundations

Masonry encompasses a wide range of materials such as brick, terra-cotta, stucco, slate, concrete, cement block, and clay and ceramic tile.

Design Guidelines for Masonry. The following guidelines should be followed when repairing, cleaning, rehabilitating or replacing historic masonry walls, trim or foundations on both commercial and residential structures.

Appropriate

- Retaining original masonry and mortar whenever possible without the application of any surface treatment.
- Protecting, maintaining and preserving masonry features and surfaces that contribute to the overall historic character of a building and site.
- Repointing only those mortar joints where there is evidence of moisture problems or when sufficient mortar is missing to allow water to stand in the mortar joint.
- Providing adequate drainage to prevent water from standing on flat, horizontal surfaces.
- Duplicating old mortar in composition, color, texture, joint size, method of application, and joint profile.
- Repairing historic masonry using recognized preservation methods.
- Repairing stucco with a mixture that duplicates the original as closely as possible in texture, color, and appearance.
- Cleaning masonry only when necessary to halt deterioration or to remove graffiti and stains, using only the gentlest method possible such as low pressure water (less than 100 psi) and soft natural bristle brushes.
- If a feature is completely missing, replacing it with a new feature, based on accurate documentation of the original feature, or a new design compatible with the scale, size, material and color of the historic building or district.

Not Appropriate

- Sandblasting or using other abrasive cleaning techniques that will damage historic masonry.
- Applying waterproof or water repellent coatings or applying surface consolidation treatments.
- Using power tools that can damage masonry units to remove mortar.
- Using mortar containing high amounts of Portland cement where the historic mortar is soft and did not contain cement.
- Applying paint to previously unpainted surfaces.
- Painting previously unpainted masonry.



402 South Fourth is an example of an historic masonry home in the East William Street Historic District. Retain original masonry and mortar whenever possible without using a surface treatment.

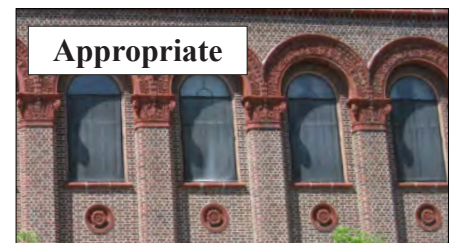

Protect, maintain and preserve masonry features and surfaces that contribute to the overall character of a historic building.

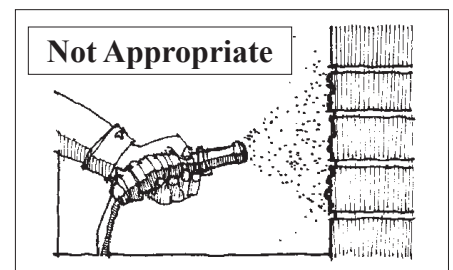

Sandblasting or using other abrasive cleaning techniques that will damage historic masonry is not appropriate.

Roof Shape, Materials, Gutters, Dormers and Chimneys

The roof shape and pitch is a primary definition of the architecture of the building, and the goal in rehabilitation is to retain the original roof shape, the original roofing material, and the original roofing features such as dormer windows, cupolas, cornices, brackets, chimneys, weather vanes, gutters, downspouts, and lightning rods.

Historic Roof Shapes. When working with historic roofs, it is helpful to be familiar with the typical historic roof shapes that are seen in Ann Arbor. The Historic Roof Shapes diagram on the next page will assist with interpretation of the design guidelines for roofs.



The roof shape and pitch is an important defining feature of a building's architecture.

Historic Roof Shapes

The following are types of historic roof shapes that are commonly seen in Ann Arbor. Most of the illustrated roof forms relate to residential structures.

Gabled Roof: A roof that consists of two sloping planes that meet at the ridge or peak. The planes are supported at their ends by triangular, upward extensions.

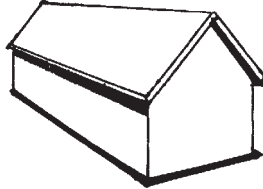

Clipped Gable or Hipped Gable Roof: The end of a roof when it is formed into a shape intermediate between a gable and a hip; the gable rises about halfway to the ridge, resulting in a truncated shape, the roof being inclined backward from this level.

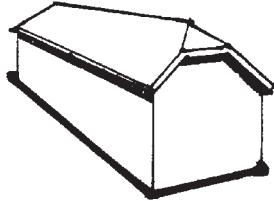

Cross Gabled Roof: Cross gable roofs have two or more gable rooflines that intersect.

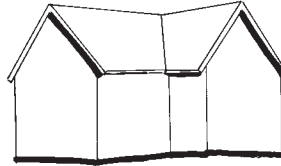

Hipped Roof: A roof with slopes on all four sides. The hip is the external angle formed by the meeting of two roof surfaces.

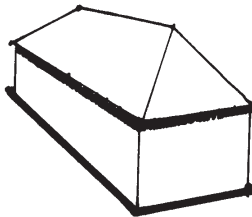

Gambrel Roof: A roof that has two, differently angled slopes on each side of the peak, the upper slope being flatter while the lower slope is steeper.

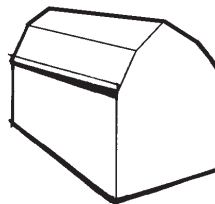

Mansard Roof: A roof with two slopes to all four sides, the lower one being steeper than the upper.

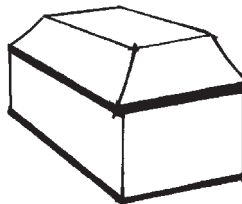

Flat Roof: A roof with a level surface. Flat roofs are often seen in commercial areas and are usually bordered by a low to moderate height parapet wall.

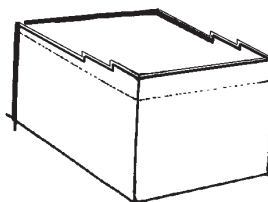

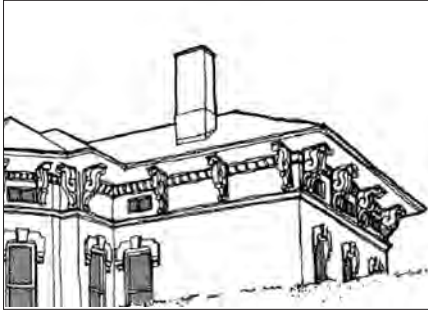

Maintain original historic roof shapes, roof materials and chimneys.

Design Guidelines for Roofs. The following guidelines should be followed when repairing, cleaning, rehabilitating or replacing historic roofs, gutters or chimneys.

Appropriate

- Retaining and maintaining original historic roofing materials, roof shape, dormers, cupolas, chimneys, and built-in or decorative gutters & downspouts.
- Maintaining historic roofing materials by keeping the roof free of leaves, trimming tree branches that touch the roof, and regularly inspecting for leaks and damage.
- Repairing historic roofing materials such as tile, slate, or metal by replacing only the deteriorated portions with exactly matching materials, and replacing deteriorated flashing to match the existing.
- Replacing historic roofing material that is deteriorated beyond repair with matching materials. If using the original is not technically feasible, then compatible substitute materials may be considered.
- Replacing non-original roofing materials with the documented historic roofing material.
- Designing and constructing a new feature when the historic feature is completely missing, such as a chimney or cupola with an accurate restoration using historical, pictorial, and physical documentation.

Not Appropriate

- Replacing historic roofing materials that are repairable.
- Installing tar paper as a finished roofing material or using roofing tar in place of flashing.
- Patching any roofing or flashing with tar or asphalt products UNLESS they match the existing roofing material.
- Covering built-in gutters or replacing them with surface mounted gutters.
- Changing the shape or configuration of an existing roof.
- Removing or altering historic roof features such as chimneys, dormers, cupolas, lightning rods, built-in or decorative gutters.
- Repairing or reconstructing chimneys with mortar that does not exactly match the original in composition, color, hardness, and joint profile.
- Installing gutters where the roof is designed to not have gutters.
- Adding chimneys, cupolas, and dormers where not appropriate.

Barrier Free Accommodations, Safety Codes and Fire Escapes

It may be necessary to make modifications to a historic building to comply with current health, safety and code requirements. Such work needs to be planned and undertaken so that it does not result in a loss of character-defining spaces, features, and finishes.

Design Guidelines for Barrier Free Accommodations, Safety Codes and Fire Escapes. The following guidelines should be followed when working with safety codes or providing barrier free accommodations and fire escapes on historic residential or commercial properties.

Appropriate

- Complying with barrier free and safety codes in a manner that ensures the preservation of character-defining features.
- When required, installing barrier free access ramps, stairways, and elevators that do not alter character-defining features of the building, keeping historic building materials intact, and that if removed in the future keep the historic building intact.
- When required, adding new stairways and elevators that do not alter existing facilities and spaces of the building.
- Removing non-original fire escapes and exterior stairs from the front of historic resources.
- Painting or staining fire escapes to match the adjacent building wall.

Not Appropriate

- Altering, damaging, or destroying character-defining spaces, features and finishes.
- Installing fire escapes on the front or street side of a property.
- Installing railings with spindles attached to the sides of the top and bottom rails.



Comply with barrier free accommodations, safety and fire codes in a manner that ensures the preservation of character defining features.



Sidewalks, walkways and landscaping contribute to the existing context within historic districts.

Site Features on Historic Properties

Site features such as driveways, walkways, landscaping and lighting contribute to the existing context within historic districts. This section provides general guidelines for site features on both commercial and residential properties. More specific guidelines that are unique to commercial or residential settings are provided in Chapter 4: Design Guidelines for Historic Residential Properties or Chapter 5: Design Guidelines for Historic Commercial Properties.

Driveways, Curb Cuts, Parking, Walkways and Other Paved Areas

Paving includes, but is not limited to, any structure or material that is not integral to any building, or is used as surface material for walks, drives or other surfaced areas. Replacement of existing paving or introduction of new paving requires review.



Paving includes any material used as a surface for walks, drives and other surface areas.

Design Guidelines for Paved Areas. The following guidelines should be followed when working with driveways, curb cuts, parking, walkways or other paved areas in both historic residential and commercial settings.

Appropriate

- Retaining and maintaining historic sidewalks, walkways, driveways, and patios/terraces.
- Designing new driveways with “radius” type curb cuts and paved with gravel, concrete, asphalt, porous pavers or brick. Stamped or patterned concrete will be reviewed on a case-by-case basis.
- Installing new parking areas, which are compatible with the scale, proportion of yard area, and characteristics of the historic district, behind buildings. These shall also be reviewed on a case-by-case basis.
- On residential properties, retaining and maintaining existing historic driveways and curb cuts, including “two track” driveways and green space between the driveway and house.

Not Appropriate

- Installing or enlarging parking areas in front of buildings.
- Installing driveways or parking areas that are too wide or large for the building site and are out of character for the district.
- Reconstructing any sidewalk, driveway, terrace, patio, and other landscape features without sufficient documentation of what the historic feature looked like.



In residential settings, it is appropriate to retain and maintain existing historic driveways including “two-track” driveways.



Retain historic sidewalks, walkways, driveways, patios and green space between drive and home.



Lighting

Although required to keep buildings comfortable and safe, the placement of lighting should have minimal impact on character defining features of a historic building. They should not introduce light levels that are incompatible with the character of the historic district. Exterior lighting includes, but is not limited to: wall mounted lights, ceiling/can lights, pole mounted lights and flood lights. Lighting will be reviewed for location, design, size, and scale. Exceptionally bright lights or improperly aimed lights can cause a change in the setting of a historic property and the district.

Design Guidelines for Lighting. The following guidelines should be followed when repairing, maintaining, replacing or installing new light fixtures in both historic residential and commercial settings.



Repair and maintain historic light fixtures that are attached to historic buildings.

Appropriate

- Repairing and maintaining historic light fixtures that are attached to historic buildings, site lighting, and street lighting.
- Attaching light fixtures so historic fabric is not damaged or destroyed.
- Where a historic light is deteriorated beyond repair, replacing it with a reproduction light fixture that matches the historic appearance. If a reproduction is not available, installing a new contemporary fixture that is inconspicuous or complements the style and character of the resource is appropriate.
- When installing a new fixture where there is no historic light fixture, using a fixture that is inconspicuous or complements the style and character of the resource.
- When introducing new site and street lighting using fixtures that are compatible with the scale and historic character of the district.

Not Appropriate

- Introducing area or security lighting that is attached to power poles and that is out of scale or out of character with the historic buildings or district.
- Introducing flood lighting on front or side building faces. All floodlights should have shields and be aimed down.
- Installing new lighting in locations that change or destroy character-defining features and materials.
- Cutting through character-defining features to install lighting.
- Illuminating building façades in residential areas with harsh floodlights.

Solar Panels

In 2007, Ann Arbor was designated by the United States Department of Energy as a Solar America City. This designation has increased awareness of individuals' energy consumption and has encouraged residents to investigate the use of alternative utilities that consume fewer natural resources, without reducing the conveniences of modern life.

In addition to the inclusion of solar panels or solar shingles to the historic resource, the resource's owner must demonstrate that the addition of the solar panels is a part of a comprehensive energy-reducing plan that is compliant with the Secretary of the Interior's Standards for Rehabilitation and Guidelines for the overall benefit of the resource.

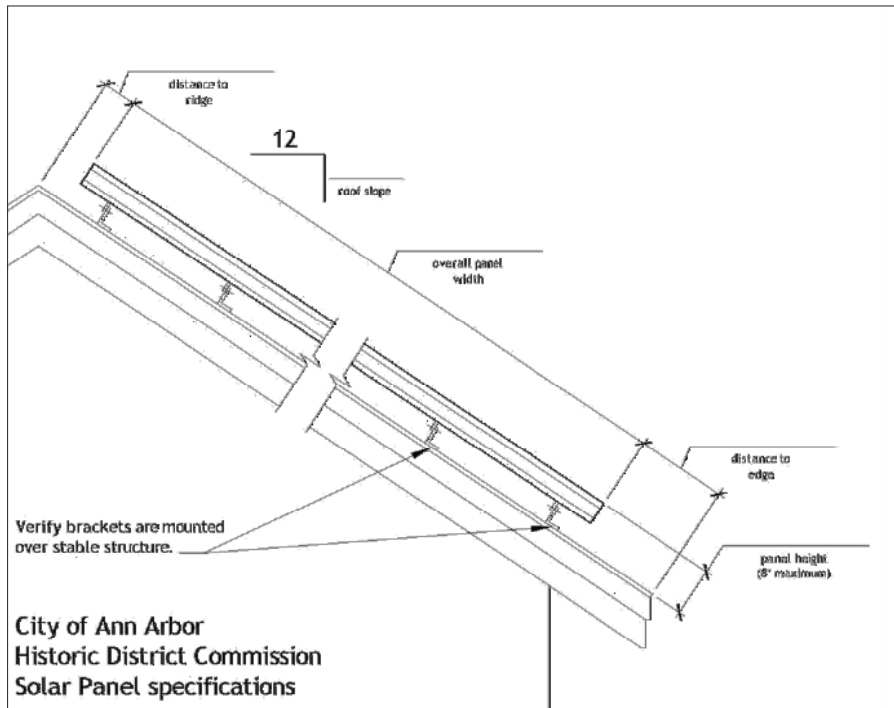

New solar panels located on roof surfaces should be installed parallel to the roof, should match or be similar in color to the roof and should not extend more than eight inches above the roof surface.

Design Guidelines for Solar Panels. The following guidelines should be followed when installing new solar panels on or near historic commercial and residential structures.

Appropriate

- Placing freestanding or detached solar collectors in locations that are not visible from the public right-of-way.
- Mounting solar panels at grade or on ground pole mountings. In the absence of an appropriate ground-based mounting location, panels should be mounted on side or rear facing roof surfaces.
- Installing mechanical and service equipment on the roof related to the solar units and their related devices so that they are inconspicuous from the public right-of-way and do not damage or obscure character-defining features.
- For sloped roof installations, mounting solar panels parallel to and within 8" of roof surface.
- On flat roof structures, installing solar panels set back from the roof edge to minimize visibility. Pitch and elevation should be adjusted to reduce visibility from the public right-of-way.
- Positioning solar panels behind existing architectural features such as parapets, dormers, and chimneys to limit their visibility.
- Using solar panels and mounting systems that are compatible in color to established roof materials.

Not Appropriate

- Mounting solar panels and their related devices on primary elevations or roofs that face the primary elevation or in planes that are highly visible from the street view. This location has the highest impact on the historic character of the historic building and all other options should be thoroughly explored.
- Placing freestanding or detached solar collectors in locations that detract from and/or destroy historic landscape materials.
- Removing historic roofing materials during the installation of solar panels.
- Removing or altering the historic roof configuration – dormer, chimneys, or other character defining features – to add solar panels.
- Placing solar shingles on character defining elevations or areas that are visible from the street facing façade.
- Any other alteration or installation procedure that will cause irreversible changes to historic features or materials.

CHAPTER 4: DESIGN GUIDELINES FOR HISTORIC RESIDENTIAL PROPERTIES

IN THIS CHAPTER

Building Elements	4-1
Site Features	4-17

This chapter presents general design policies for the maintenance and rehabilitation of existing residential historic resources. Refer to Chapter 3: Design Guidelines for All Historic Properties for supplementary information and guidelines on additions to historic structures and other historic building elements and site features.

Historic Residential Building Elements

Historic residential building elements include doors, awnings, porches, decks and patios. The individual elements of residential accessory structures and the appearance and location of mechanical equipment are also important. The following section provides background information and guidelines for the repair, rehabilitation, maintenance, replacement and location of historic building elements on residential structures.

Doors

Doors are important features of the exterior of a residential building. The front door is one that everyone passing by and entering the property sees. If the original door still exists it is important to retain and repair it so the historic integrity of the property is maintained.

Historic Door Parts. When working with historic doors it is helpful to be familiar with their significant features. The Historic Door Parts diagram on the next page will assist with interpretation of the design guidelines for doors on historic residential structures.



Doors are important historic residential building elements.

Historic Door Parts

The numbered historic door parts glossary terms are keyed to the numbers on the diagram to the left. Familiarity with historic door parts will assist in planning for maintenance and rehabilitation of historic doors.

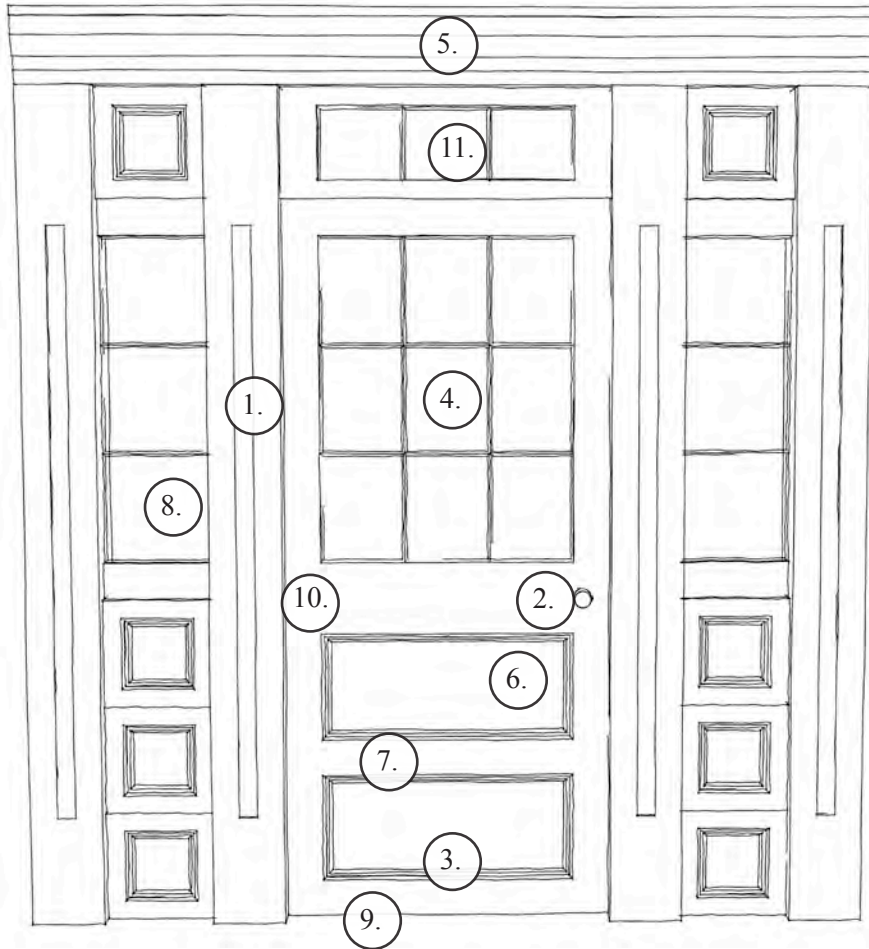

Fanlight (not pictured): A semicircular window over the opening of a door, with radiating bars in the form of an open fan.

1. Frame: The fixed, outer portion of the door.

2. Hardware: The operating parts of the door; i.e., the doorknob.

3. Kickplate: The area at the foot of the door, designed to be occasionally kicked.

4. Light: The glass within the door; can refer to the number of divided areas of glass.

5. Lintel: The horizontal structural member of the frame above the door.

6. Panel: A portion of the door that is sunk below the surrounding area, distinctly set off by molding or some other decorative device.

7. Rail: A horizontal member of the door.

8. Sidelight: The framed area of fixed glass alongside a door opening.

9. Sill: A horizontal member that forms the lower side of the door opening.

10. Stile: A vertical member of the door.

11. Transom: A horizontally oriented fixed window above the door.

Design Guidelines for Residential Doors. The following guidelines should be followed when repairing, cleaning, rehabilitating or replacing a historic door on a residential structure.

Appropriate

- Retaining, repairing and maintaining original doors, hardware, and trim, including transoms, sidelights, and surrounds.
- Replacing a missing original or non-original door with a design that matches original doors remaining on the house, or with a compatible new design and material that fits the style and period of the house and the existing opening. The Commission will review materials on a case-by-case basis.
- Retaining, repairing, and maintaining original storm/screen doors.
- Installing new wood or painted aluminum or steel screen/storm/security doors that do not have bars or ornamentation, and have structural members that are aligned with the primary door, or have an appropriate design for the period and style of the house.
- Replacing original doors that are deteriorated beyond repair with a door that matches the existing exactly in design, size, proportions, profile, and material.

Not Appropriate

- Removing or replacing repairable original door, screen/storm door, trim, transoms, sidelights or surrounds.
- Enlarging, reducing, or otherwise changing the door opening size.
- Installing a new screen/storm/security door that is not full view or that has ornamentation.
- Replacing a non-original door with a new door that is not compatible with the house style, or that has frosted or decorative glass that is not replicating an original door.
- Installing a new door opening.

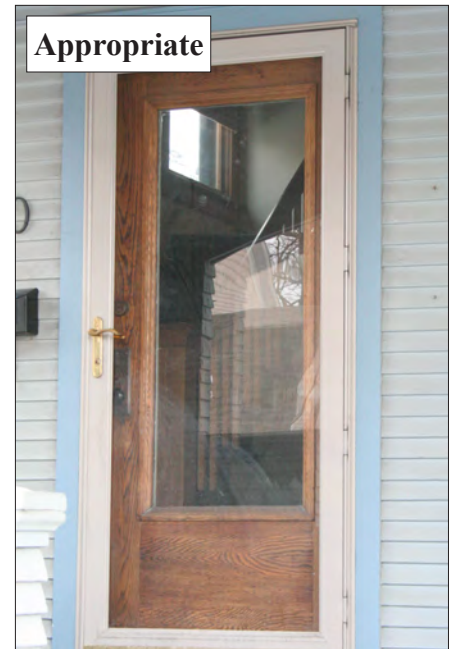

Retain, repair and maintain original doors.

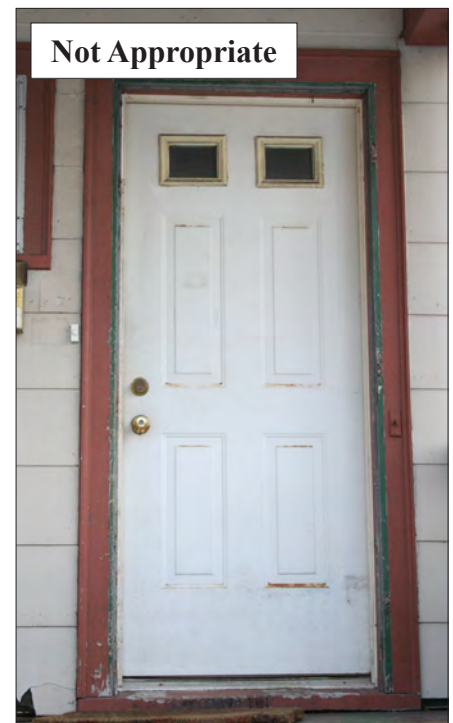

It is not appropriate to replace an original door with a new door that does not match the house style.

Appropriate

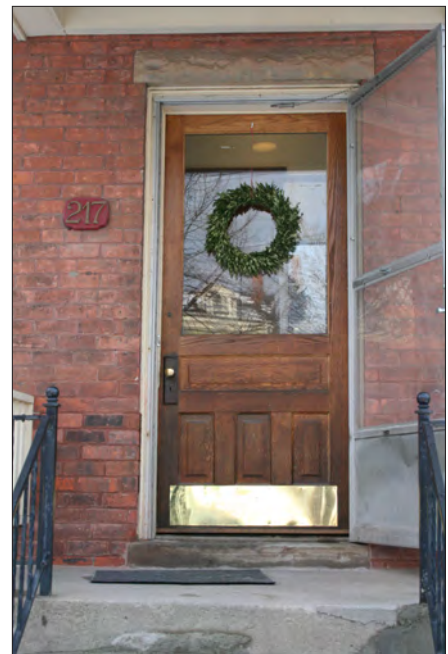
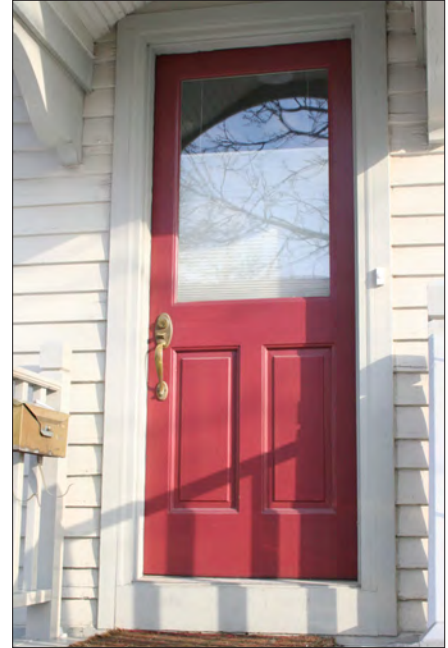
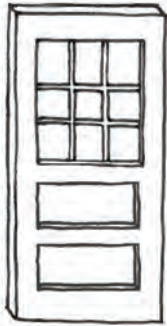

Replace a missing original or non-original door with a design that matches original doors remaining on the house, or with a compatible new design and material that fits the style and period of the house and the existing opening.

It is appropriate to repair, rehabilitate and maintain original historic doors and storm doors on residential structures.

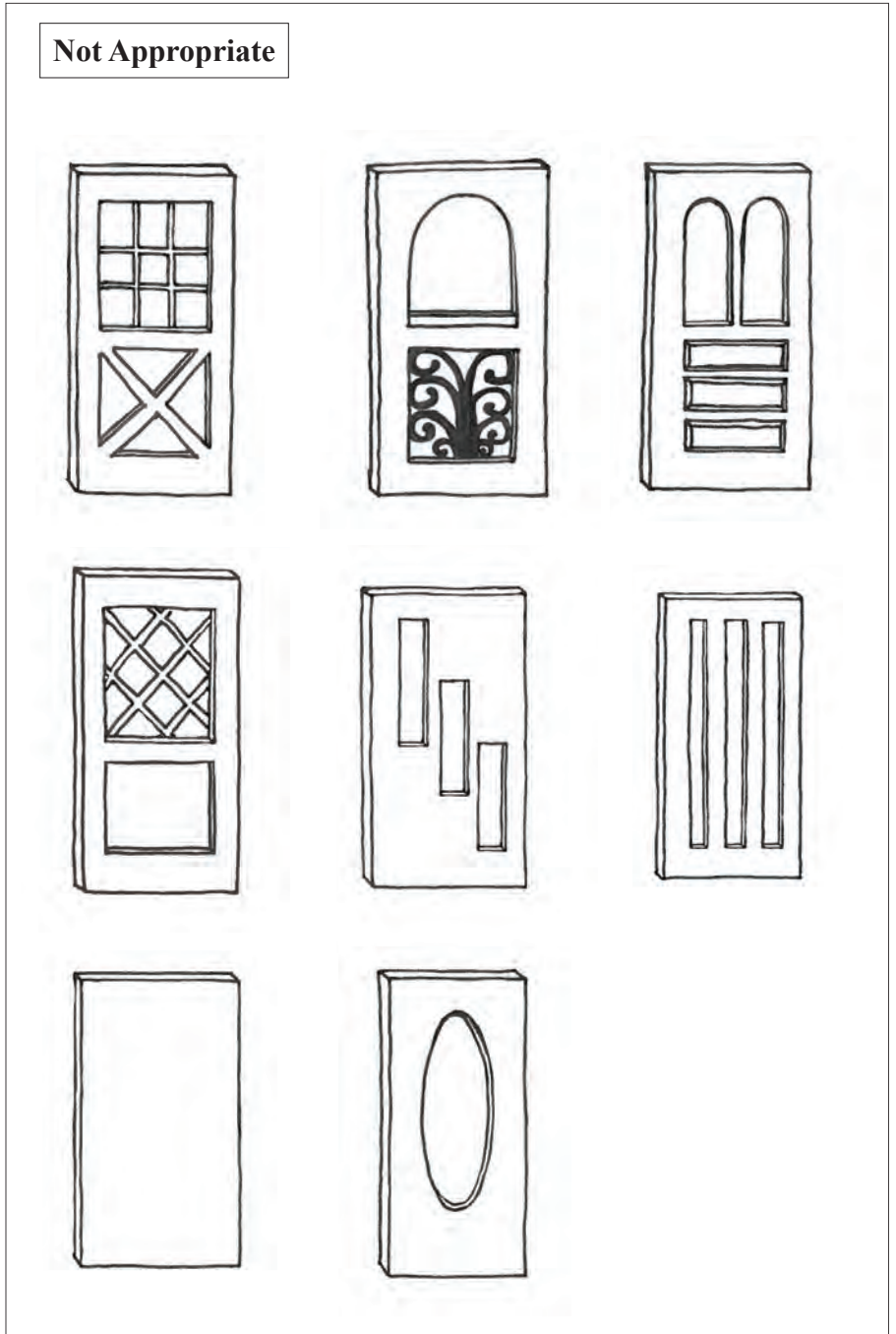

It is not appropriate to install a new screen door that is not full view or that has ornamentation.

It is not appropriate to replace a historic door with one that has little transparency, is highly ornamented or is otherwise incompatible with the historic architectural style of the house.

Awnings

Awnings have played an important role in the function of historic structures. They have been a tool for providing climate control by blocking out the sun’s heat while still admitting daylight and fresh air.

Design Guidelines for Residential Awnings. The following guidelines should be followed when installing an awning on a historic residential structure.

Appropriate

- When installing a new awning, fitting the awning within the existing opening.
- Installing the frame so historic trim and character-defining features are not destroyed or obscured.
- Using canvas, vinyl-coated canvas, or acrylic fabrics.
- Using an awning that is compatible in scale and form to the historic structure.
- Installing awning supports through mortar joints, not masonry units.

Not Appropriate

- Using curved fixed frame awnings.
- Using aluminum or other metal awnings when evidence or documentation of historic metal awnings is not present.

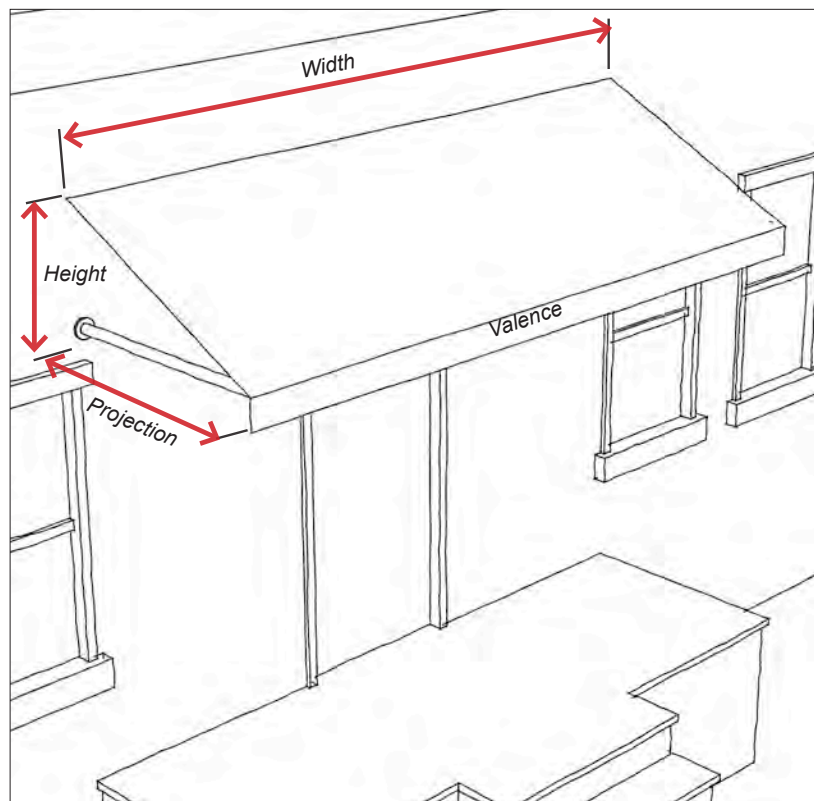

New awnings should fit within the existing opening and incorporate historic proportions.

Porches

Porches include, but are not limited to, structures attached to or immediately adjacent to a permanent structure. They are used as, or connected to, an entrance to the primary structure. Porches can be roofed or unroofed and may or may not have permanent weatherproof walls and windows. A porch contributes to the overall architectural style of the building, and its prominence on a property makes its preservation important. If the historic entrance or porch is completely missing, the new entrance or porch may replicate the original using accurate documentation or a new design compatible with the historic character of the building and the district. Alternate materials will be considered by the Commission on a case-by-case basis.



Porches contribute to the overall architectural style of a residential structure.

Historic Porch Parts

The numbered historic porch parts glossary terms are keyed to the numbers on the diagram to the right. Familiarity with historic porch parts will assist in planning for maintenance and rehabilitation of historic porches.

1. Balustrade: A railing at the side of a staircase or balcony

2. Bottom Rail: The horizontal bottom member of the balustrade

3. Deck/Floor

4. Fascia: A horizontal band or board that is often used to conceal rafters

5. Newel Post: A post used to support the base of a stair railing

6. Pediment: The triangular end of a gable roof

7. Pilaster: A rectangular column projecting slightly from a wall

8. Post/Column: The vertical members supporting the porch roof

9. Riser: The vertical face of a stair step

10. Roof

11. Skirting: Finish trim hiding area beneath the porch floor

12. Soffit: The underside of a structural component

13. Stair Railing

14. Stringer: The diagonal supporting member for treads and riser

15. Top Rail

16. Tread: The part of a step that is stepped on

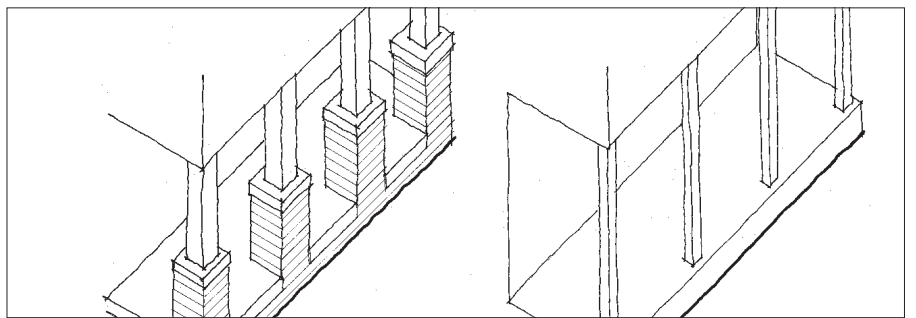
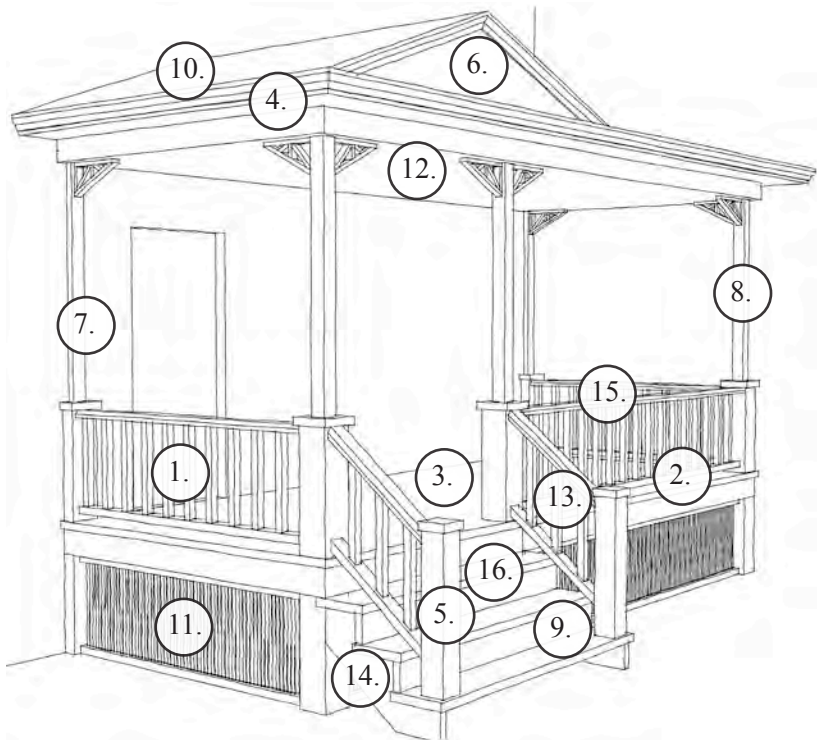

Posts or columns are an important element of historic porches. A number of post styles are described in the following pages with additional guidance regarding the appropriateness of each post style.



Repair and maintain all porches and do not allow them to deteriorate.

Overall Design Guidelines for Residential Porches. The following guidelines should be followed when repairing, maintaining or installing new elements on a residential porch. The guidelines should also be followed when building a new porch. Additional guidance for specific porch elements such as posts, railings, floors and roofs follow the overall design guidelines.

Appropriate

- Repairing and maintaining all porches and not allowing them to deteriorate. Repairs which match the original in scale, material, and design are not considered changes.
- Painting or staining all exposed wood elements.
- Replacing a porch which has deteriorated beyond repair, using physical evidence to guide the new work.
- Installing a new porch and entrance on secondary elevations may be appropriate if it does not diminish the building’s architectural character and the design and materials are compatible with the building and the site.
- Using replacement features that match the documented historic design. If no documentation exists, using a simple, plain design.

Not Appropriate

- Removing or radically changing an entrance or porch which is important in defining the historic character of the property.
- Removing an entrance or porch because the building has been re-oriented to accommodate a new use.
- Enclosing a porch in a manner that results in a diminution or loss of historic character.
- Using stock, unframed, cross-hatched skirting in a diamond pattern.
- Using decking as a flooring material that does not have a closed butt joint.
- Using pressure treated wood except where structural members are hidden and come in contact with the ground.
- Removing detail or trim materials.
- Creating a false historical appearance by adding a porch, entrance, feature, or detail that is conjectural or comes from other properties.



Existing Condition: Craftsman style house with an enclosed porch.



Preferred Approach when historical documentation is available: Craftsman style house with a replacement porch designed similar to that seen historically.

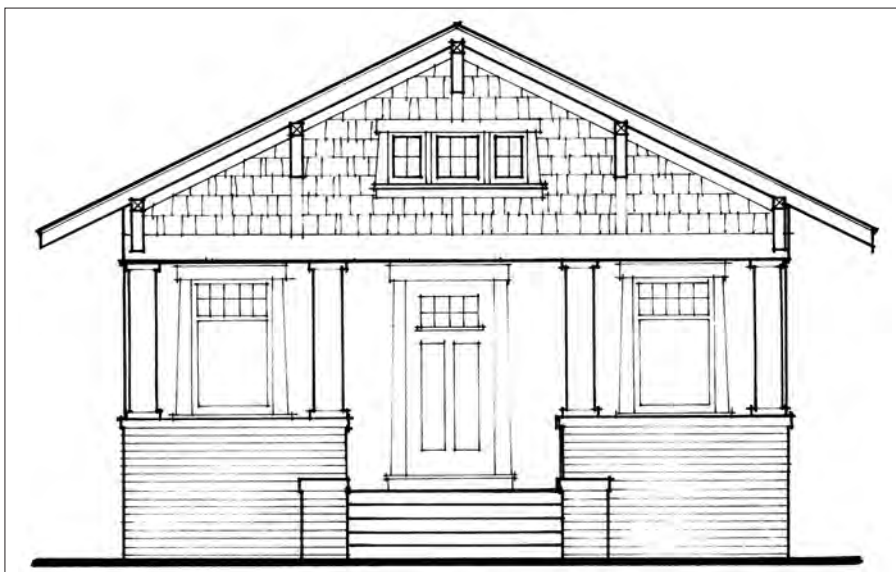

Acceptable Approach when historical documentation is not available: Craftsman style house with a simplified interpretation of a traditional porch design.

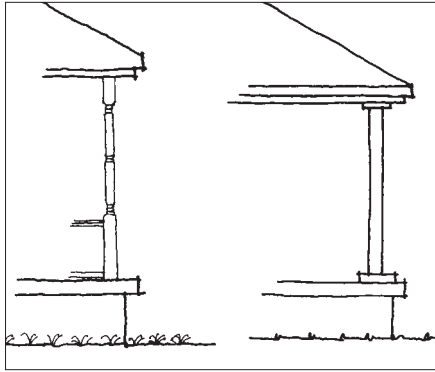

Porch Posts: Posts are an important element of historic porches. Porch posts can be either full height or short. For replacement porch posts, the replacements must match the existing posts. Non-original posts may also be replaced if documentation exists that depicts the original post size, shape, and design. If no documentation exists, replacement posts must be simple in design.

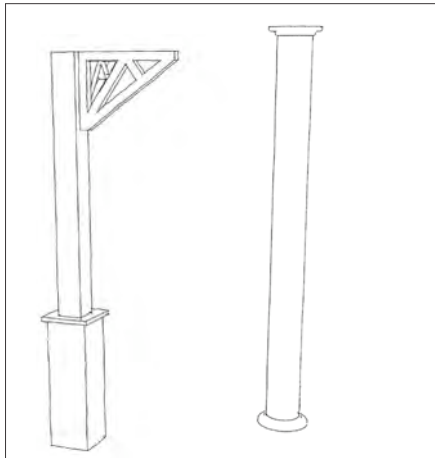

Types of full height porch posts vary depending on the architectural style of the structure.

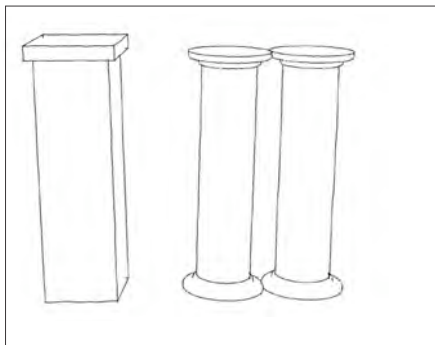

Types of short porch post vary depending on the architectural style of the structure.

Newel Posts. Newel posts are the specialized posts used to support stair railings on historic porches. They should generally correspond to the other porch posts in thickness whether round or square. Where porch posts are turned, square newel posts are recommended. Turned newel posts are not recommended under any circumstances. The top railing may butt to the newel post or extend over the top. Where the railing butts to the post, the top should be finished with either flat cap slightly larger than post or decorative wood ball.

Porch Railings: Railings are also an important element of historic porches. Historic railing materials and elements should be treated appropriately and railings should be installed at the proper height. Appropriate treatments for primary elements of historic porch railings include:

- Spindles
 - Should match original; if originals are not available, new ones may be round, turned or square, between 1 and 2 inches thick depending on height and spacing.
 - Spacing must meet building code requirements.
 - Spindles must butt to top and bottom railings.
 - Spindles nailed to sides of top or bottom railings are not appropriate.
- Top Railing
 - Should match original; if original is not available, the new one may consist of a 2x4 with beveled top and plain, rounded or grooved sides (railing section).
- Bottom Railing
 - Should match top railing (without grooved sides) and should be set between 2 and 4 inches above the porch deck.

If a porch railing must be replaced, the height of the new railing should match the historic railing height as determined by an existing historic railing or scars on the porch wall. If no evidence exists, the railing height should not exceed 30 inches. Note that this differs from the minimum height of 36 inches specified in the building code. Should safety be an issue, alternative design solutions will be considered. Such solutions could include the use of trellises, window boxes and intermediate rails.

Solid masonry railings and foundations (stone or brick) should be repointed with mortar to match the existing in color and profile. Rock-faced block porches should be repaired rather than replaced, if possible. Split-face or other modern block should not be used as a replacement material. Solid wood railings and foundation (clapboard or shingle) should be repaired rather than replaced.



Railings are an important element of historic porches.

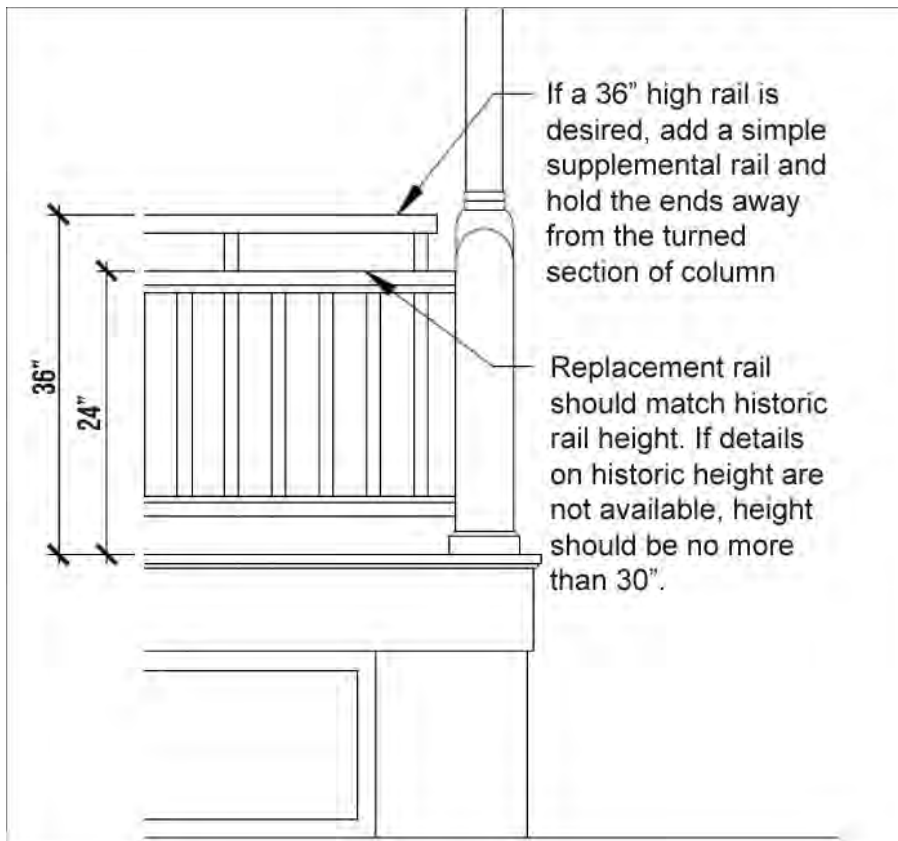

If a porch railing must be replaced, it should match the historic railing height or should not exceed 30 inches in height if information on historic railing height is not available.

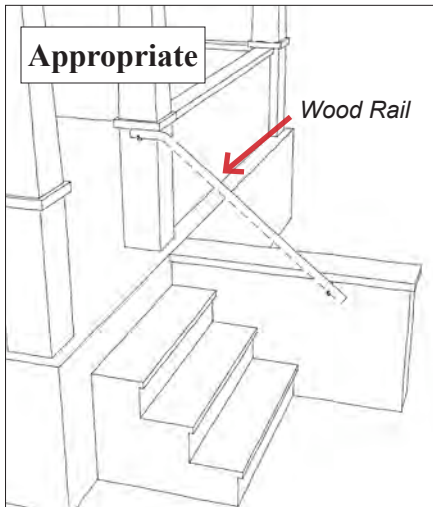

Where the porch railing is solid masonry and the historic steps are flanked by stepped masonry walls, a new handrail should be a round painted wood rail supported by metal brackets. Other solutions may be acceptable but will require the prior approval of the Historic District Commission. Metal pipe and wrought iron handrail railings are not appropriate for any type of historic porch.

Handrails on Porch Steps. Since most historic porch steps never had handrails but are now required to do so by code, it is important to make them as unobtrusive as possible. Stair railings should be installed at the proper height and proper materials should be used.

Where the porch is wood and has an original wood railing, new handrails for porch steps should be designed to match. If the wood railing is solid, plain 2x4 handrails extending over 4x4 newel posts are recommended.

Where the porch rail is solid masonry and the historic steps are flanked by stepped masonry sidewalls, metal brackets supporting a round, painted wood rail are appropriate. Whether this choice will work depends on the height of the flanking walls at the bottom and top. Other solutions may be acceptable but will require the prior approval of the Historic District Commission.

Porch Floor. The floor or deck is an important element of a historic porch. The traditional material for a porch floor is 1x3 tongue and groove fir, laid perpendicular to the front wall of the house. The ends of the board may be trimmed with a small molding or left untrimmed. New flooring must have a closed butt joint.

Porch Steps. Historic porch steps should be treated properly or replaced in a sensitive manner. Porch step elements and their appropriate treatment include:

- Risers
 - Must be closed.
- Treads
 - May be one or two boards wide.
 - Rounded nosings are recommended.

New pre-cast concrete porch steps are not recommended. Existing original concrete steps should be repaired with new concrete in the same color and profile as the original.

Porch Skirting. The skirting beneath a porch is an important visual element and should be treated properly. Proper strategies for framing and screening porch skirting include:

- Framing
 - Wood skirting should be framed with boards, generally 6 inches wide on the top and at least 4 inches wide on the corners and bottom.
- Screening
 - Should match the original screening
 - If the original is not available, new screening may be traditional framed vertical wood lattice
 - Decoratively cut vertical boards are appropriate
 - Vinyl lattice is not recommended
 - Lattice may not be attached on the outer side of the framing boards
 - The sides of the steps may be enclosed with matching screening or the screening may extend behind the steps to complete the enclosure

Porch Roof. The traditional roof for a full front porch is hipped with a shallow pitch. If decorative elements such as small gables or Mansard edges exist, they should be maintained. New elements should not be added.

Architectural Trim on Porches. The architectural trim on a porch should be compatible with the style of the house. Brackets, upper spindle work, decorative shingles and moldings should be repaired rather than replaced. Any replacements should match the original in size, shape, and material. Conjectural features and/or architectural trim elements from other buildings may not be added to a porch.

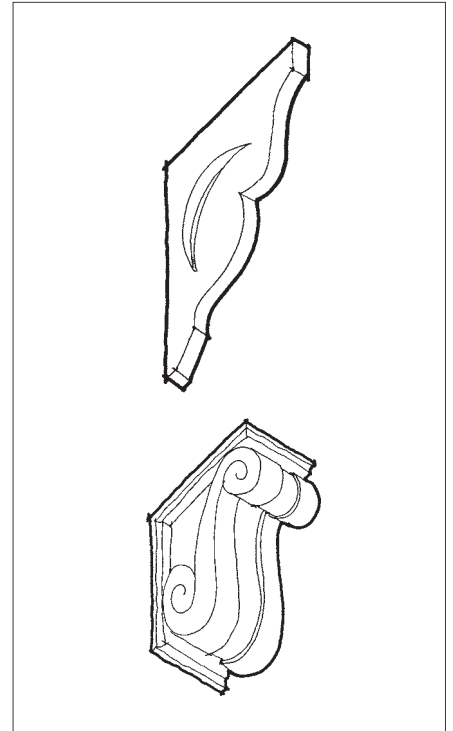

Brackets and spindle work on a historic porch should be repaired rather than replaced.

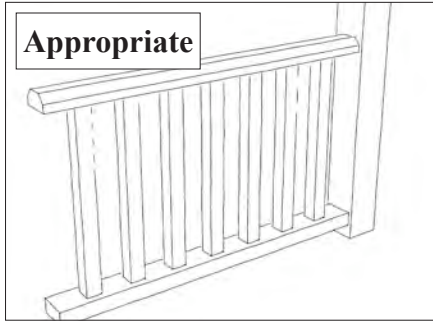

Appropriate

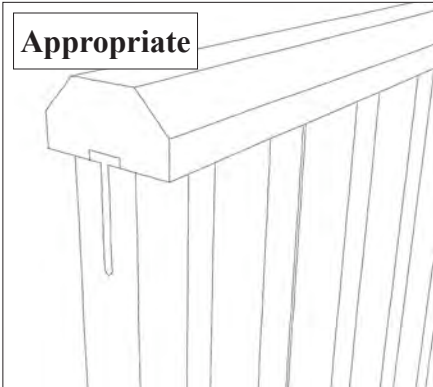

Appropriate

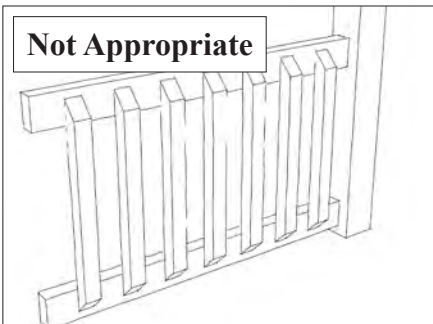

Not Appropriate

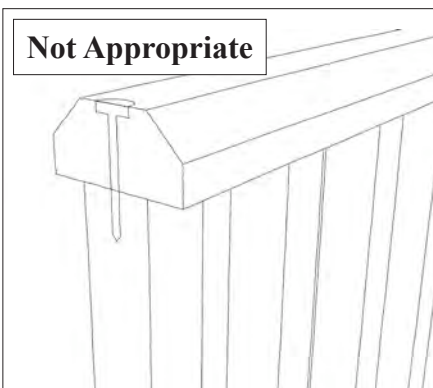

Not Appropriate

Use deck railings that have a chamfered top and bottom rail, and simple square or round spindles that are attached to the underside and top of the rails.

Residential Decks and Patios

Decks include, but are not limited to, rear yard elevated platforms. Patios are flush with the ground level. To be considered a deck or patio it must be located in the rear yard, unless special circumstances exist. For deck-type structures on the sides or front of the house, see the design guidelines for porches.

Design Guidelines for Residential Decks and Patios. The following guidelines should be followed when repairing, maintaining or installing new elements on a residential deck or patio. The guidelines should also be followed when building a new deck or patio.

Appropriate

- Installing a deck in the rear of the property that is subordinate in proportion to the building.
- Installing a deck that is free standing (self supporting) so that it does not damage historic materials.
- Using railings that have a chamfered top and bottom rail, and simple square or round spindles that are attached to the underside and top of the rails.
- Installing flooring made of wood or composite wood.
- Installing railings made of wood. Custom railing designs will be reviewed on a case-by-case basis.
- Installing a patio flush with grade using stone, brick pavers, or concrete. Custom materials will be considered on a case-by-case basis.
- Ensuring that a deck or patio drains away from the historic resource.

Not Appropriate

- Installing railings with spindles attached to the sides of the top and bottom rails.
- Installing top and bottom rails that are vertically proportioned (taller than wide like a 2x6 turned vertically).

Satellite Dishes, Antennas and Mechanical Equipment

Satellite dishes and antennas assist in the viewer’s ability to receive video programming signals from a variety of sources. Mechanical equipment and systems include but are not limited to all exterior devices related to heating, electric, plumbing, air conditioning, ventilation, and media.

Design Guidelines for Residential Satellite Dishes, Antennas and Mechanical Equipment. The following guidelines should be followed when installing mechanical equipment on a historic residential property.

Appropriate

- Placing satellite dishes and antennas so they are not visible from a public right-of-way.
- If affixing satellite dishes and antennas to a structure, using methods and placement that do not damage historic materials.
- Installing mechanical equipment and wiring in a location so it is not visible from a public right-of-way.
- Installing new air conditioning units and related mechanical equipment in such a manner that historic materials and features are not damaged or obscured.
- Installing vertical runs of ducts, pipes, and cables in closets, service rooms, or wall cavities, so that they are not exposed on the exterior of the building.
- Using screening such as vegetation and fencing around mechanical equipment.
- Painting mechanical equipment to blend with the house or landscape.

Not Appropriate

- Installing satellite dishes and antennas on the front of a building.
- Installing a new mechanical system that changes or destroys character-defining features and materials.
- Installing vertical runs of duct, pipe and cable in places where they will damage or obscure character-defining features or materials.
- Cutting through architectural character-defining features to install mechanical equipment, antennas, satellite dishes, and related equipment.

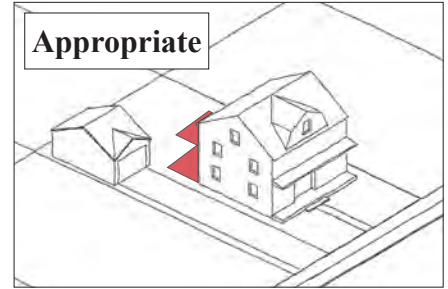

Because satellite dishes, antennas and mechanical equipment are not original elements of historic residential properties, they should be as unobtrusive as possible.

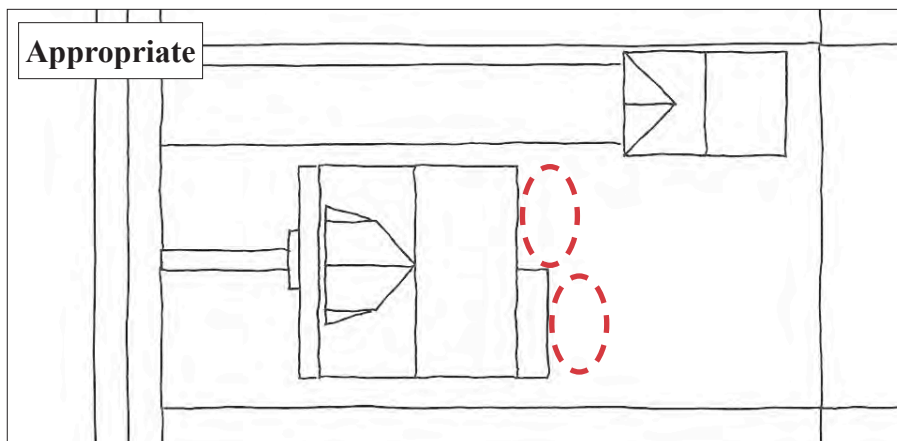

Install mechanical equipment in a location that is not visible from a public right-of-way.



Maintain and repair historic garages and other accessory structures.

Residential Accessory Structures

Accessory buildings are defined as enclosed structures such as garages, carriage houses, barns, and sheds. Historic garages, carriage houses, and barns should be preserved and repaired. The same standards that apply to primary buildings apply to accessory structures.

Design Guidelines for Residential Accessory Structures. The following guidelines should be followed when repairing, maintaining or rehabilitating historic residential structures. When building a new residential accessory structure, use the design guidelines in Chapter 7: New Construction.

Appropriate

- Maintaining and repairing historic barns, garages, sheds, trellises, and other accessory structures to match the historic materials and configuration.
- Maintaining and repairing historic doors and windows on historic barns and garages to match the existing materials and configuration.
- Where elements of historic out-buildings are deteriorated beyond repair, replacing the elements in kind.
- Replacing a non-historic or missing garage door with a new door in keeping with the style and period of the existing garage, using the historic opening size.

Not Appropriate

- Introducing new structures or site features that are out of scale with the property or the district or are otherwise inappropriate.
- Removing historic barns, garages, sheds, trellises, or other historic accessory structures.
- Replacing repairable original historic doors, garage doors, and windows.
- Altering historic barns, garages, and sheds by using materials, configurations, and designs that do not match the existing or historic appearance.

Site Features of Historic Residential Properties

Site features on historic residential properties include general landscape features as well as site fencing and walls. New or replacement site features on historic residential properties should respect the character defining features of the historic district and property with which they are associated. The following section provides background information and guidelines for the treatment of site features on historic properties.



Mature trees, hedges, and other historic plantings should be retained and maintained on historic residential properties.



Landscaping includes the use of plantings on a property.

Landscape Features

Landscaping includes but is not limited to, the movement and contouring of soils and use of plantings at a property.

Design Guidelines for Residential Landscape Features. The following guidelines should be followed when maintaining historic landscape features.

Appropriate

- Retaining historic relationships between buildings, landscape features, and open spaces.
- Preserving and maintaining natural landforms and designed grades.
- Retaining and maintaining mature trees, hedges, and other historic plantings.
- Retaining and maintaining stone curbs, hitching posts, and carriage steps.

Not Appropriate

- Removing mature trees, hedges, and other historic landscaping.
- Planting new landscaping where it will conceal the character-defining features of the building or the site.
- Paving the lawn area between the sidewalk and the street.
- Introducing any new building, streetscape, or landscape feature that is out of scale or otherwise inappropriate to the district’s historic character.
- Introducing a new landscape feature or plant material that is visually incompatible with the site or destroys site patterns or vistas.



Retain historic relationships between buildings, landscape features and open spaces.

Fencing and walls

Fencing and walls include any structure that is not integral to any building and is used as a barrier to define boundaries, screen off, or enclose a portion of a property. Historic fencing and walls should be preserved and repaired.

Design Guidelines for Residential Fencing and Walls. The following guidelines should be followed when repairing or maintaining historic residential fences and walls or when building new fences and walls on historic residential properties.

Appropriate

- Repairing and maintaining historic fences and walls using standard preservation practices to retain their historic materials and appearance.
- Installing fences and walls that meet Chapter 104 of the Code of the City of Ann Arbor, and that are no higher than three (3) feet in the front yard and six (6) feet in the rear yard.
- Locating new fences and walls on lot and setback lines whenever possible.
- Using wood (picket or alternating board), wrought iron or metal (wrought iron style), or chain link (rear yards only) for fencing.
- Using brick or stone for new walls. Custom masonry products will be reviewed on a case-by-case basis.
- Installing custom designs which will be reviewed on a case-by-case basis.
- Using hedges in place of fencing, and planting vegetation along fencing.

Not Appropriate

- Removing a repairable historic fence or wall.
- Installing fences or walls over three (3) feet in height in the front yard and over six (6) feet in height in the rear yard.
- Impeding clear vision at intersections by exceeding a height of thirty (30) inches in height within twenty five (25) feet of an intersection.



Wood picket fences are appropriate in historic residential settings.

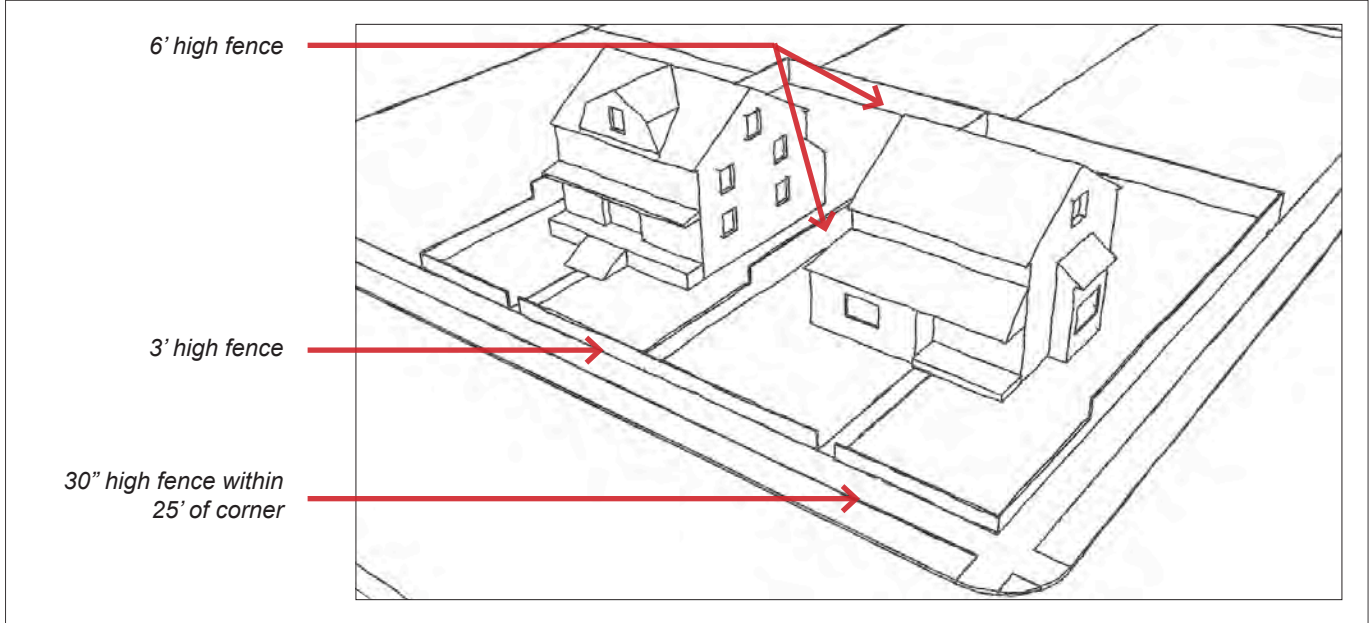

New fences and walls must meet Chapter 104 of the Code of the City of Ann Arbor.

CHAPTER 5: DESIGN GUIDELINES FOR HISTORIC COMMERCIAL PROPERTIES

IN THIS CHAPTER

Building Elements 5-1

This chapter presents general design policies for the maintenance and rehabilitation of existing commercial historic resources. Please refer to Chapter 3: Design Guidelines for All Historic Properties for supplementary information and guidelines on additions to historic structures and other historic building elements and site features.

Historic Commercial Building Elements

Historic commercial elements include storefronts, doors and awnings. The following section provides background information and guidelines for the repair, rehabilitation, maintenance, replacement and location of historic building elements on commercial structures.



Many of Ann Arbor's historic commercial buildings are finely crafted and include intricate architectural details.



Rehabilitation of historic commercial buildings can improve the pedestrian-oriented character of downtown Ann Arbor as shown in the above illustrations of the 300 Block of South Main Street in the Main Street Historic District.



A nearly continuous series of ground floor storefronts contributes to the pedestrian-oriented character of the Main Street Historic District.



Many commercial storefronts in Ann Arbor feature recessed entries. In some cases, the entry floor and ceiling feature tile work or other decorative elements.

Storefronts

The ground level of many historic commercial buildings features a storefront area. In most cases, the storefront is the most prominent feature of the building. The pattern of traditional storefronts is an important defining feature in most of Ann Arbor’s historic commercial districts. They contribute to a pedestrian-friendly character and generate activity and interest at the street level.

Preserving significant historic storefronts and restoring altered or missing storefront features are important preservation goals. When planning for the rehabilitation of a storefront, an evaluation of the building’s historic integrity should be conducted. To gather information on the original design of a missing or altered storefront feature, examine the existing building for any clues regarding the original location of glass, window supports, transoms or other elements.

Historic Storefront Types and Elements. When working with historic storefronts it is important to have an understanding of storefront types and their typical functional and decorative features. The following pages include Historic Storefront Types and Historic Storefront Elements diagrams to assist with interpretation of the design guidelines for historic commercial storefronts.



The storefront is the most prominent feature of most historic commercial buildings.

Historic Storefront Types

The following are common types of historic commercial storefront.

Early 19th Century Storefront:

These storefronts are constructed with heavy timber and have divided display windows and simple detailing.

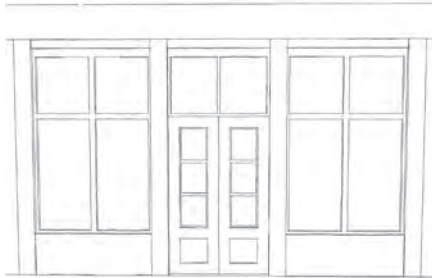

Mid and Late 19th Century Storefronts:

These storefronts include an elaborately detailed cornice, cast iron columns and undivided display windows.

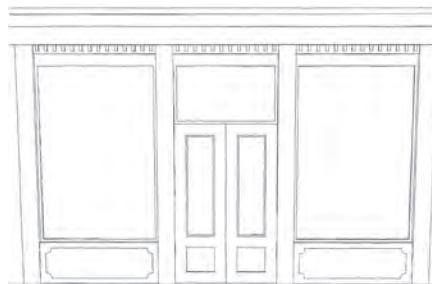

Late 19th Century Storefronts:

These storefronts include simple detailing, transom windows and a recessed entrance.



Early 20th Century Storefronts:

These storefronts include metal framed display windows, a glass grid above the display windows and a recessed entrance.

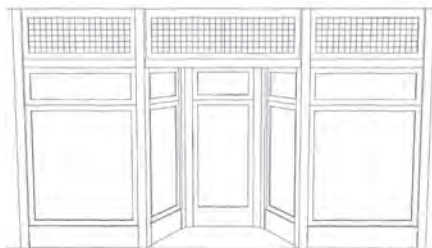

Historic Storefront Elements

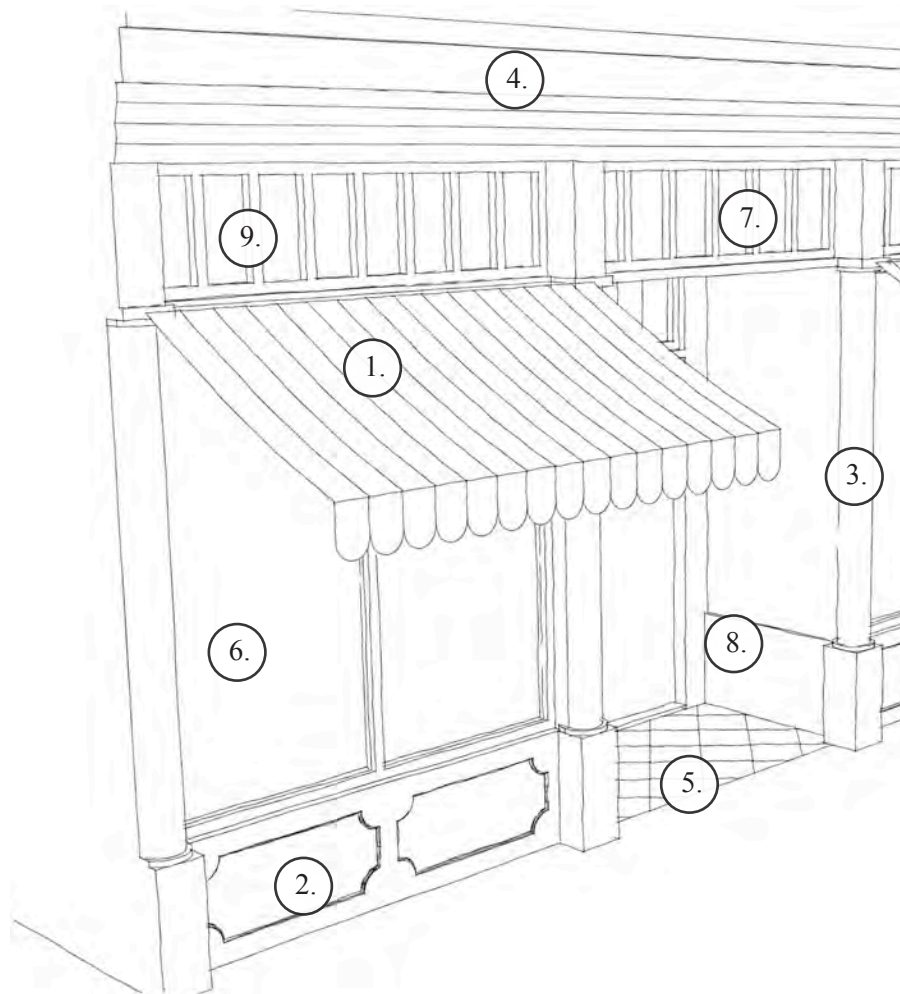

The numbered historic storefront element glossary terms are keyed to the numbers on the photograph to the right. Familiarity with historic storefront elements will assist in planning for maintenance and rehabilitation of storefronts.

1. Awning: A canopy made of canvas to shelter people or things from rain or sun.

2. Bulkhead/Kickplate: The area beneath the display window.

3. Columns: A round vertical support.

4. Cornice: A horizontal molded projection that crowns or completes a building or wall. The cornice is the uppermost part of an entablature.

5. Decorative Ceilings and Floors: Floor or ceiling areas in a recessed storefront with decorative tiling, painting or pressed metal elements.

6. Display Window: The main portion of glass on the storefront where goods and services are displayed.

7. Entablature: The area above the entryway in which the transom is contained.

8. Entry: The area surrounding the front door, usually set back from the sidewalk in a protected recess.

9. Transom: The upper portion of the storefront separated from the main display window by a frame.

Design Guidelines for Storefronts. The following guidelines should be followed when repairing, rehabilitating or replacing a historic commercial storefront.

Appropriate

- Protecting, maintaining and preserving storefronts and their functional and decorative features that are important in defining the overall historic character of the building such as display windows, signs, doors, transoms, kick plates, corner posts, and entablatures using recognized preservation methods.
- Protecting and maintaining masonry, wood, and architectural metals which comprise storefronts through appropriate treatments such as reinforcement of historic materials, cleaning, rust removal, limited paint removal, and reapplication of protective coating systems.
- Repairing storefronts as needed, which may include replacing parts that are deteriorated beyond repair or that are missing with matching or compatible substitute materials. Missing parts must be appropriately documented.
- Replacing in-kind an entire storefront that is too deteriorated to repair, if the overall form and detailing are still evident, using the physical evidence to guide the new work.
- Designing and constructing a new storefront when the historic storefront is completely missing. It may be an accurate restoration using historical, pictorial, and physical documentation; or may be a new design that is compatible with the size, scale, and material of the historic building. New designs should be flush with the façade and be kept as simple as possible.
- Replacing an entire storefront when repair is not possible.

Not appropriate

- Removing or radically changing storefronts and their features which are important in defining the overall historic character of the building so that the character is diminished.
- Changing the storefront so that it appears residential rather than commercial in character.
- Removing historic material to create a recessed arcade.
- Changing the location or configuration of the storefront's historic main entry.
- Introducing new reproduction or salvaged architectural elements that were not historically part of the building.
- Creating a false historical appearance because the replaced storefront is based on insufficient historic, pictorial, and physical documentation.
- Installing a new storefront that is incompatible in size and material with the historic building and district.
- Removing paint from wooden storefronts that were historically painted and applying clear stains or sealers to create a natural wood appearance.
- Using reflective glass that makes it difficult for pedestrians to see into the storefront.
- Setting a storefront back from its historic position at the sidewalk edge.

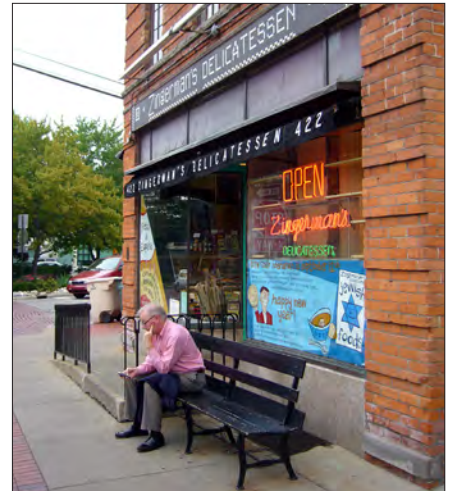

The high level of transparency seen on many of Ann Arbor's commercial storefronts promotes an active, pedestrian-oriented character along the sidewalk.



Retain, repair and maintain original doors and trim including surrounds and transoms.

Commercial Entries

Historic commercial buildings feature two types of entries: the storefront entry and the entry to the upper floors. The storefront entry often included a wood door or a pair of doors with a large glass panel, usually recessed between the display windows. The entry to the upper floors usually included a wood door, sometimes with a glass panel, flush with the façade and to one side of the storefront.

Design Guidelines for Entries. The following guidelines should be followed when repairing, rehabilitating or replacing historic commercial entries and associated doors.

Appropriate

- Retaining, repairing and maintaining original doors and trim, including surrounds and transoms.
- Replacing missing original doors with a design that matches original doors remaining on the building, or with a compatible new design that fits style and period of the building and the existing opening.
- Retaining, repairing, and maintaining original screen doors.
- Replacing original doors that are deteriorated beyond repair with doors that match the existing exactly in design, size, proportions, profile, and material.

Not appropriate

- Removing or replacing repairable original doors, screen/storm doors, trim, transoms, sidelights or surrounds.
- Enlarging, reducing, or otherwise changing the door opening size.
- Replacing non-original doors with new doors that do not match the building style, or that have frosted or decorative glass that is not replicating an original door.
- Installing new door openings.

Roll-Down Security Grills. Roll-down security grills, if required, will be reviewed on a case-by-case basis. The mounting and location of the storage box and equipment shall be installed so it does not destroy or obscure historic materials.

Commercial Awnings, Canopies and Banners

Awnings, canopies and banners are noteworthy features of historic commercial buildings and their continued use is encouraged.

Retractable canvas awnings were a traditional feature of historic storefronts. They provided a covered space in front of the store to protect customers from the weather; they shaded the interior of the store during the summer months; and they contributed to the design of the building by providing a dash of color and by softening the transition between the upper and lower portions of the façade.

The traditional shape for a storefront awning on a historic building is triangular when viewed from the side with a short vertical valence at the bottom. The valence may be loose or fixed. A variation on the traditional shape may include gables over the entrance.

Defining Awnings, Canopies and Banners. As shown in the diagram on the next page, awnings and canopies are shade structures projecting from the top of the first floor of a commercial building. Canopies are usually rigid while awnings are made of flexible canvas.



The use of awnings over windows, entries and storefronts is encouraged.

Defining Awnings, Canopies and Banners

Awnings, canopies and banners are defined and illustrated below.

Awning: A roof like structure made of canvas that serves as a shelter over a walkway, storefront, window or entry.

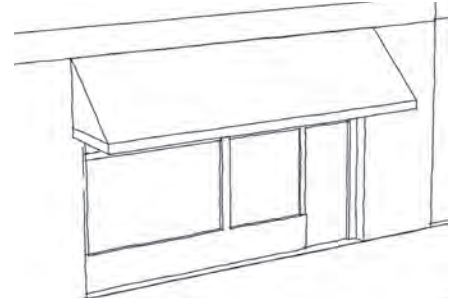

Canopy: A protective roof like covering, sometimes ornamental, mounted on a frame over a walkway, storefront, window or entry.



Banner: An ornamental element made of canvas attached above a storefront, window or entry.



Design Guidelines for Commercial Awnings and Banners. The following guidelines should be followed when designing awnings for new commercial buildings in historic districts or when repairing, rehabilitating or replacing historic commercial awnings and banners. The Historic District Commission will grant more latitude to awning design for non-contributing commercial buildings.

Appropriate

- Mounting a standard storefront awning so that the bottom of the fixed frame is at least 7 feet above the sidewalk, although 8 feet is preferred. Consideration should be given to the height of neighboring awnings.
- Projecting the awning from the face of the building no more than 4 feet.
- Attaching the awning just below the storefront cornice and fitting it within the storefront opening.
- Mounting the awning or banners on masonry structures through the mortar joints and not through brick, stone, or terra cotta
- Using canvas, vinyl-coated canvas, or acrylic fabrics for awnings and banners.
- Lighting awnings and banners from above.
- Installing banners and awnings so they do not cover or require the removal of any historic detail.

Not appropriate

- Using translucent, backlit awnings.
- Using “box” or curved or “waterfall” shaped awnings.
- Covering the piers or space above the cornice with the awning or canopy.
- Replacing historically retractable awnings with fixed awnings.

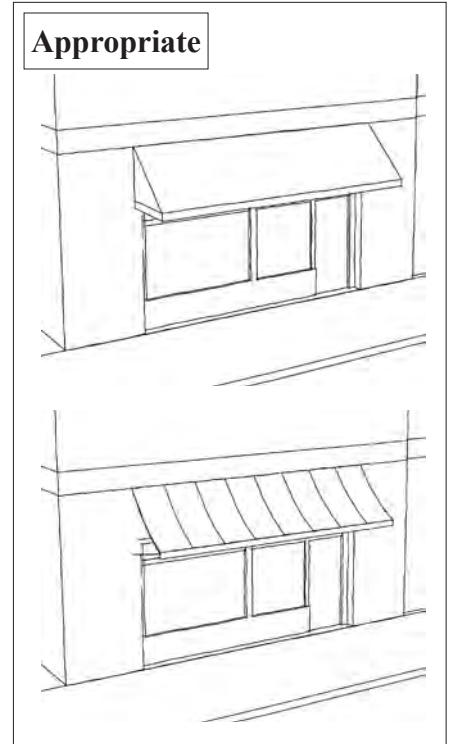

Triangular shaped canvas awnings are preferred.

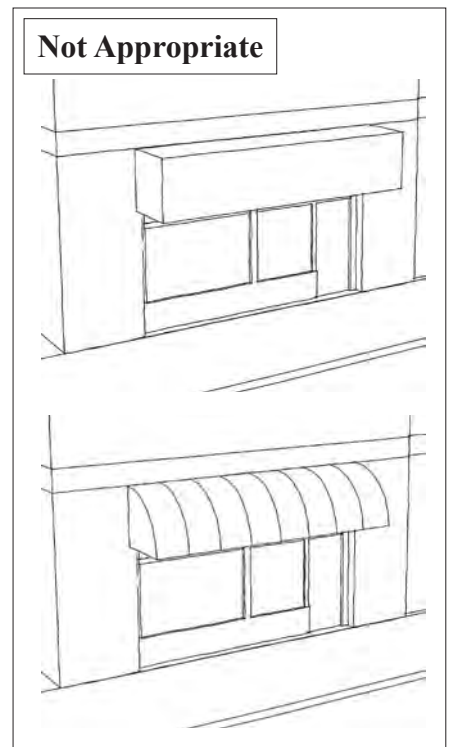

The use of box or waterfall shaped awnings is not appropriate.



Consolidating signage for multiple businesses located at a single storefront is encouraged to reduce the total number of signs on a building.



New signage in historic commercial districts should be compatible in size, style, material and appearance to the historic resource or district.

Historic signage was designed to fit within the architectural features of a building with out obscuring the building design. Signage was sometimes painted onto display windows.

Signs

The Ann Arbor Historic District Commission classifies signs as character-defining features that have significant impact on a building’s appearance. Therefore, to avoid detracting from a district’s character, some care must be exercised when introducing new or modified signage. Owners and tenants are encouraged to select designs that do not conflict with a building or its immediate environment. While large, brightly lit signs may draw attention to the establishment within, they tend to detract from the unique character of the district.

Signage is an integral part of the character of historic commercial settings. Signs include any outdoor display or message intended to advertise or inform. They can be secured to, or painted on a structure or an accessory structure or posted in the ground adjacent to the structure. The number of signs should, however, be limited.

New sign designs should be coordinated with the surrounding buildings and signs in terms of size, color, intensity and lighting. Simple, understated signs that complement the historic architecture are most often successful, both in advertising the establishment and reinforcing the district’s character. Often, the building’s character can be reinforced by considering natural signage locations on the building: above the storefront transom, on an awning or projecting from the building on a blade sign.

Historically, street level signs mounted on the exterior of the primary facade advertised the primary business of a building. Upper story businesses used window signs. Although most signs were a few square feet in area, larger signs were used for cultural or institutional facilities such as theaters or office blocks. In a few instances, major retailers also used large signs, although they were limited in number.

Signs were historically mounted to fit within architectural features without obscuring building design. In many cases, signs were mounted flush above the storefront, just above moldings. Other signs were located between columns, centered in “panels” on a building face or painted onto display windows.

Signage in historic districts must be in compliance with Chapter 61 of the Ann Arbor City Code, Signs and Outdoor Advertising and must be approved by the Historic District Commission using the design guidelines on the next page.



Design Guidelines for Signs. The following guidelines should be followed when replacing or installing new signage in historic commercial settings.

Appropriate

- Preserving historic painted signs where they exist.
- Installing signage that is subordinate to the overall building composition.
- Mounting signage to fit within existing architectural features using the shape of the sign to help reinforce the horizontal lines of moldings and transoms seen along the street.
- Installing signage in the historic sign band area of the building, typically the area above the transoms or just above the storefront.
- Attaching signage through masonry joints, not masonry units, or through materials that can be easily repaired, such as wood, when the signage is removed.
- Painting signs on window glass, or using vinyl decal letters, that can be removed without damaging historic materials.
- Installing signage that is compatible in size, style, material, and appearance to the historic resource and district.
- Installing signage that is lit from external light fixtures above or below the sign.
- Placing signs to align with others along the commercial block face.
- Consolidating signage for multiple businesses at a single storefront to reduce the total number of signs on the building.
- Providing a consolidated directory listing sign for all offices in a building to reduce the total number of signs on the building.

Not appropriate

- Installing signs that are too large or that are made from a material that is incompatible with the historic building or district.
- Obstructing character-defining features of a historic building with signage.
- Installing signs through brick, stone, or other masonry units in a manner that damages historic materials.
- Installing signs that are made of unfinished, pressure treated wood, or that have a rough, unfinished surface.
- Installing signs that have interior illumination or are backlit.
- Installing signs that are overly complex, use more than three or four colors or use fluorescent colors.
- Installing signs that use highly reflective materials that are difficult to read.
- Installing permanent free-standing signs.
- Mounting signs to project off of an awning.
- Installing several signs to advertise a single business.



Providing a consolidated directory listing for all offices in a building is encouraged to reduce the total number of signs on the building.

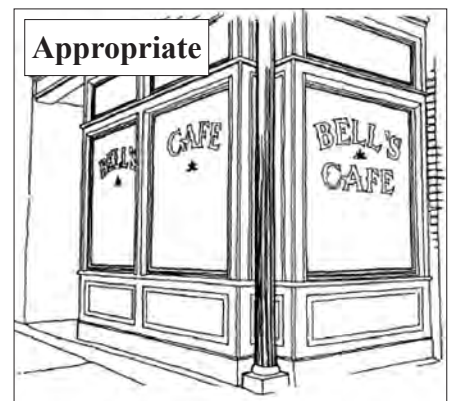

Painting signs on window glass is appropriate.



Install signage in the historic sign band area of the building.



Retain and preserve metal features that contribute to the overall character of a historic building.

Use of Metal

Some historic commercial buildings have metal cornices, window hoods, storefronts, and other trim that strongly contribute to the architectural character of the building. Although not always visible, metal flashing, parapet caps, and gutters are equally important to maintain to prevent water from entering the building.

Design Guidelines for Historic Metal. The following guidelines should be followed when repairing, rehabilitating or replacing metal elements on historic commercial buildings.

Appropriate:

- Retaining and preserving metal features that contribute to the overall historic character of the building and site.
- Providing regular maintenance of metal and the protective paint coating to prevent corrosion, rust, and water damage.
- Providing proper drainage so that water does not stand on flat, horizontal surfaces or accumulate in curved, decorative features.
- Patching or replacing deteriorated metal in kind so that adjacent dissimilar metals do not cause corrosion.
- Cleaning soft metals such as lead, tin, copper, terneplate, and zinc with appropriate methods that do not abrade the surface.
- Cleaning hard metals such as cast iron, wrought iron, and steel, using the gentlest means possible that do not abrade the surface.
- Replacing features that are deteriorated beyond repair with a new feature that matches the design, dimension, texture, and material of the original. If the original material is technically infeasible a new material will be considered on a case-by-case basis.
- Replacing a missing feature with a new feature based on pictorial, physical, or documentary evidence, or installing a new feature that is compatible in scale, size, and material with the historic building and district.

Not appropriate:

- Using asphalt products such as roofing tar to patch flashing or other metal surfaces as it corrodes metals.
- Cleaning soft metals with abrasive methods such as grit blasting.
- Introducing architectural metal feature or details that create a false historical appearance.
- Repairing existing metals with exposed fasteners unless they were part of the original design.
- Mounting signs, lights, or other items in such a manner that damages or punctures original metal building components.

Mechanical Equipment

Although required to keep buildings comfortable and safe, the placement of mechanical systems and wiring should have minimal impact on character-defining features of a historic building. They should not introduce massing or noise that are incompatible with the character of the historic district.

Mechanical equipment and systems include, but are not limited to, all exterior devices related to heating, electric, plumbing, air conditioning, ventilation, and media.

Design Guidelines for Mechanical Equipment. The following guidelines should be followed when installing mechanical equipment in historic commercial settings.

Appropriate

- Attaching mechanical equipment so historic fabric is not damaged or destroyed.
- Installing mechanical equipment and wiring in locations on the roof, rear elevations, or in alleys, so they are not visible from a street.
- Installing new air conditioning units and related mechanical equipment in such a manner that historic materials and features are not damaged or obscured.
- Installing vertical runs of ducts, pipes, and cables in the interior of the building in closets, service rooms, or wall cavities so they are not visible on the exterior.
- Using compatible screening around outdoor mechanical equipment such as vegetation and fencing.
- Painting mechanical equipment to blend with the historic building.

Not appropriate

- Installing new mechanical systems or wiring in locations that change or destroy character-defining features and materials.
- Installing vertical runs of duct, pipe and cable in places where they will damage, obtrude upon, or obscure character-defining features or materials.
- Cutting through character-defining features to install mechanical equipment, antennas, satellite dishes, and related equipment.

CHAPTER 6: DESIGN GUIDELINES FOR RELOCATION & DEMOLITION

IN THIS CHAPTER

Relocation	6-1
Demolition	6-3

This chapter presents design policies and guidelines for the relocation or demolition of historic resources. The purpose of an historic district is to protect historic properties. Therefore, it is generally inappropriate to demolish or relocate historic resources within historic districts.

Relocation of Historic Resources

Moving an existing building that contributes to the character of a district should be avoided whenever possible. However, it may occasionally be appropriate to relocate an historic resource from its original site to another location within the historic district as an alternative to demolition.



Although moving a building that contributes to the character of a historic district should be avoided, it may occasionally be appropriate to do so in order to avoid demolition.

Inappropriate relocation of historic resources could result in a loss of integrity of the setting and environment of the historic district. Therefore, it is important to consider the following questions when reviewing the possible relocation of historic resources:

- Will removal of the structure from a historic district adversely affect the overall character of the historic district and adjacent structures?
- Is the structure threatened with demolition?
- Is relocation the only alternative?
- Is the structure significant enough architecturally or historically to warrant moving it?
- Is the structure sound enough to survive a move?
- Will the introduction of the structure into a historic district adversely affect the overall character of the historic district and adjacent structures?
- Will the structure fit into the period of significance of the district; is its style, architectural quality, size and scale compatible with the surroundings of the proposed new location?
- Will the move damage significant district site features, such as a tree canopy, etc.?



Historic structures should not be moved unless relocation is the only alternative. It is important to determine that the structure is sound enough to survive the move and that significant site features would not be damaged by the move.

Demolition of Historic Structures

It is vital that all historic properties be preserved, wherever feasible, so that the integrity of the historic district will be sustained. Demolition of historic buildings is therefore strongly discouraged. **Although zoning code may allow a larger building on the property, this is not meant to encourage or approve the demolition of historic buildings.** The demolition of a historic resource will only be permitted if the conditions to issue a Notice to Proceed are met.

Notice to Proceed

Work within a historic district shall be permitted through the issuance of a notice to proceed by the commission if any of the following conditions prevail and if the proposed work can be demonstrated by a finding of the commission to be necessary to substantially improve or correct any of the following conditions:

- (a) The resource constitutes a hazard to the safety of the public or to the structure's occupants.
- (b) The resource is a deterrent to a major improvement program that will be of substantial benefit to the community and the applicant proposing the work has obtained all necessary planning and zoning approvals, financing, and environmental clearances.
- (c) Retaining the resource will cause undue financial hardship to the owner when a governmental action, an act of God, or other events beyond the owner's control created the hardship, and all feasible alternatives to eliminate the financial hardship, which may include offering the resource for sale at its fair market value or moving the resource to a vacant site within the historic district, have been attempted and exhausted by the owner.
- (d) Retaining the resource is not in the interest of the majority of the community.

Evidence of Undue Financial Hardship

The commission may at its sole discretion solicit expert testimony and/or require that the applicant make submissions concerning any or all of the information set forth below:

- (a) Estimate of the cost of the proposed construction, alteration, demolition, or removal and an estimate of any additional cost that would be incurred to comply with the recommendations of the commission for changes necessary for the issuance of a notice to proceed;
- (b) A report from a licensed engineer or architect with experience in rehabilitation as to the structural soundness of any structures on the property and their suitability for rehabilitation;

- (c) Estimated market value of the property in its current condition; after completion of the proposed construction, alteration, demolition, or removal; after any changes recommended by the commission; and, in the case of a proposed demolition, after renovation of the existing property for continued use;
- (d) In the case of a proposed demolition, an estimate from an architect, developer, real estate consultant, appraiser, or other real estate professional experienced in rehabilitation as to the economic feasibility or rehabilitation or reuse of the existing structure on the property;
- (e) Amount paid for the property, the date of purchase, and the party from whom purchased, including a description of the relationship, if any, between the owner of record or applicant and the person from whom the property was purchased, and any terms of financing between the seller and buyer;
- (f) If the property is income-producing, the annual gross income from the property for the previous 2 years; itemized operating and maintenance expenses for the previous 2 years; and depreciation deduction and annual cash flow before and after debt service, if any, during the same period;
- (g) Remaining balance on any mortgage or other financing secured by the property and annual debt service, if any, for the previous 2 years;
- (h) All appraisals obtained within the previous 2 years by the owner or applicant in connection with the purchase, financing, or ownership of the property;
- (i) Any listing of the property for sale or rent, price asked and offers received, if any, within the previous 2 years;
- (j) Assessed value of the property according to the 2 most recent assessments;
- (k) Property taxes for the previous 2 years;
- (l) Form of ownership or operation of the property, whether sole proprietorship, for-profit or nonprofit corporation, limited partnership, joint venture, or other;
- (m) Any other information the owner wishes to provide or the Commission deems necessary.
- (n) In the event that any of the information is not reasonably available to the owner, cannot be obtained by the owner, or may not be disclosed without a substantial adverse impact upon the owner, the owner may file with the commission a description of the information which cannot be obtained and describe the reasons why such information cannot be obtained or provided.

CHAPTER 7: DESIGN GUIDELINES FOR NEW CONSTRUCTION

This chapter presents design policies and guidelines for new construction in historic districts. While historic districts will remain dynamic, with alterations to existing structures and construction of new buildings occurring over time, the character of the neighborhood and historic district must be respected. The design policies and guidelines presented in this chapter are intended to ensure that new buildings respect their surroundings and do not compromise the integrity of the city’s historic districts.

A number of general principles apply to all new construction while more detailed principles apply depending on the setting. Certain specific principles should be applied to new construction in historic residential settings while others apply to historic commercial settings. This chapter presents both general and setting-specific design guidelines. Because the Downtown Ann Arbor Design Guidelines apply to new construction in downtown historic districts, information on the interpretation of those guidelines in historic commercial settings is also provided.

IN THIS CHAPTER

General Principles for all	
New Construction	7-2
New Residential Construction	7-4
New Commercial Construction	7-6



While change will continue to occur, the character of each historic district must be respected.



While a number of general principles apply to all new construction in historic districts, some principles depend on whether the construction is within a historic residential or commercial setting.



It is important to consider the historic district's existing features such as height, building form, details and massing when planning new construction.

General Principles for New Construction in Historic Districts

The success of new construction within a historic district relies on understanding its distinctive architectural character. Preservation does not mean that a neighborhood or historic district must be frozen in time. New buildings should, however, reinforce the basic visual characteristics of a block or historic district. This does not imply, however, that a new building must look old. In fact, imitating historic styles is generally discouraged. Rather than imitating older buildings, a new design should relate to the fundamental characteristics of the historic district while also conveying contemporary stylistic trends.

The following features of surrounding historic buildings and streetscape are especially important to consider when planning new construction on residential or commercial properties in historic districts.

- Setbacks
- Height
- Building Form
- Building Scale
- Building Massing
- Proportion
- Roof Shape
- Materials
- Building Features
- Building Details

When new construction is designed to reference and respect these features of surrounding historic properties, visual compatibility results.



The success of new construction within a historic district relies on understanding the distinctive architectural character of the district.

Guidelines for All New Construction

The following general guidelines should be followed when planning new construction on residential or commercial properties in historic districts.

Appropriate

- Retaining site features that are important to the overall historic character
- Retaining the historic relationship between buildings, landscape features and open space
- Designing new features so they are compatible with the historic character of the site, district, and neighborhood
- Basing the site location of new buildings on existing district setbacks, orientation, spacing and distance between adjacent buildings
- Designing new sidewalks, entrances, steps, porches and canopies to be consistent with the historic rhythm established in the district
- Designing new buildings to be compatible with, but discernible from, surrounding buildings that contribute to the overall character of the historic district in terms of height, form, size, scale, massing, proportions, and roof shape

Not Appropriate

- Introducing any new building that is out of scale or otherwise inappropriate to the setting's historic character
- Introducing a new feature that is visually incompatible with or that destroys the patterns of the site or the district
- Introducing new construction onto a site or in a district, which is visually incompatible in terms of size, scale, design, materials, and texture or which destroys relationships on the site or the district



Where the street facades of most nearby historic buildings are vertical in proportion (taller than they are wide), it is appropriate to maintain vertical proportions on the facade of a new infill building.



The setback pattern within historic residential neighborhoods generally provides for a front yard and detached sidewalk.

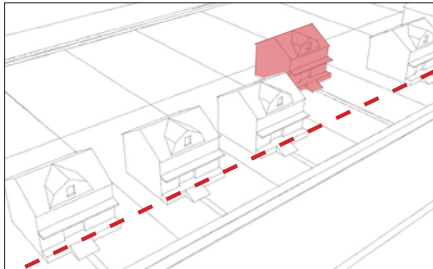

It is not appropriate to place a primary structure outside the historic pattern of front yard setbacks that exist along a residential block.

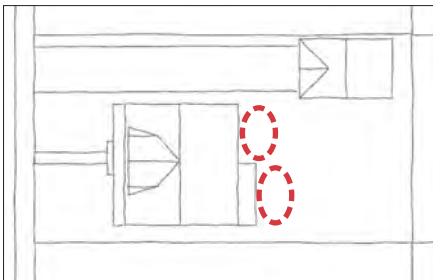

It is appropriate to place utility connections at the rear of residential properties or at other locations that minimize visibility from the street.

New Construction in Historic Residential Settings

Designing a new residential structure to fit within the historic character of a neighborhood requires careful consideration. Particular attention should be given to spacing, placement, scale, orientation, and size and shape of the window and door openings seen on surrounding structures, as well as the design of the doors and windows themselves. The selection of appropriate exterior materials and finishes depends on an understanding of the composition, scale, module, pattern, texture, and sheen of the existing materials and finishes on the surrounding historic properties.

Guidelines for New Construction in Historic Residential Settings

The following general site and building design guidelines should be followed when planning new construction on residential properties in historic districts:

Appropriate

- Maintaining the existing spacing of front and side yard setbacks along a block as seen from the street
- Orienting the front of a house towards the street and clearly identifying the front door
- Designing a new front façade that is similar in scale and proportion to surrounding buildings that contribute to the overall character of the historic district
- Designing the spacing, placement, scale, orientation, proportion, pattern and size of window and door openings in new buildings to be compatible with surrounding historic buildings
- Selecting materials and finishes that are compatible with historic materials and finishes found in surrounding buildings that contribute to their historic character
- Placing utility connections at the rear or other locations that minimize visibility from the street

Not Appropriate

- Paving a high percentage of a front yard area or otherwise disrupting the landscape pattern within front yard setbacks
- Placing a structure outside of the existing pattern of front yard setbacks along a historic residential block

Guidelines for New Accessory Structures in Historic Residential Settings

Accessory buildings include garages, carriage houses, sheds, and other enclosed structures. The general guidelines for new construction on historic residential properties apply to accessory structures. However, the following additional guidelines should also be followed:

Appropriate

- Retaining the historic relationship between buildings, landscape features, and open spaces
- Locating sheds and garages in the rear yard
- Using exterior wall and roof materials that are compatible with historic materials on the main structure and in the neighborhood
- Using a roof shape and pitch that replicates the shape and pitch of the roof of the main structure
- Using windows and doors that are compatible in proportion and style to the main structure and the neighborhood

Not Appropriate

- Introducing new construction onto the building site, which is visually incompatible in terms of size, scale, design, materials, and texture or which destroys historic relationships on the site
- Locating a shed or garage in the front yard or in side yards in front of the main structure
- Designing a garage or other accessory structure that is taller or larger than the main house



It is appropriate to continue the historic pattern of locating residential garages, sheds and accessory structures in the rear yard area.

New Construction in Historic Commercial Settings



Although some other historic commercial settings do exist, most historic commercial settings are within Downtown Ann Arbor such as the State Street Historic District.

A historic commercial setting occurs where the surrounding historic structures were built for commercial use and where current zoning allows for commercial uses. New construction in historic commercial settings should reinforce the traditional character of the block and historic district while supporting the continued economic vitality of older areas of the city.

The general design guidelines for new construction in historic districts apply to all new construction in historic commercial settings. As described below, the Downtown Ann Arbor Design Guidelines also apply to new construction that is in a historic district within the downtown area. Please consult with Historic District Commission staff for additional information on the applicability of design guidelines within historic commercial settings.



New construction in historic commercial settings should reinforce the traditional character of the block and historic district.

Downtown Historic Districts

Downtown Ann Arbor is the civic, economic and cultural heart of the community. As the area’s traditional center, downtown is rich in historic resources. Landmark buildings and historic districts accent the urban fabric and provide a context for the future development of downtown. These historic resources are an important part of downtown’s pedestrian-friendly character and future economic development.

Downtown includes all or part of nine historic districts as shown on the map below. New construction in these areas should be sensitive to the traditional context from which downtown has evolved and should be designed to maintain and enhance downtown as a desirable place to live, work and visit. The guidelines in both this chapter of the Historic District Design Guidelines and the guidelines in the separate Downtown Ann Arbor Design Guidelines apply to new construction on downtown sites that are in historic districts. The Ann Arbor Historic District Commission reviews all projects in historic districts.



The State Street Historic District is located in Downtown Ann Arbor.

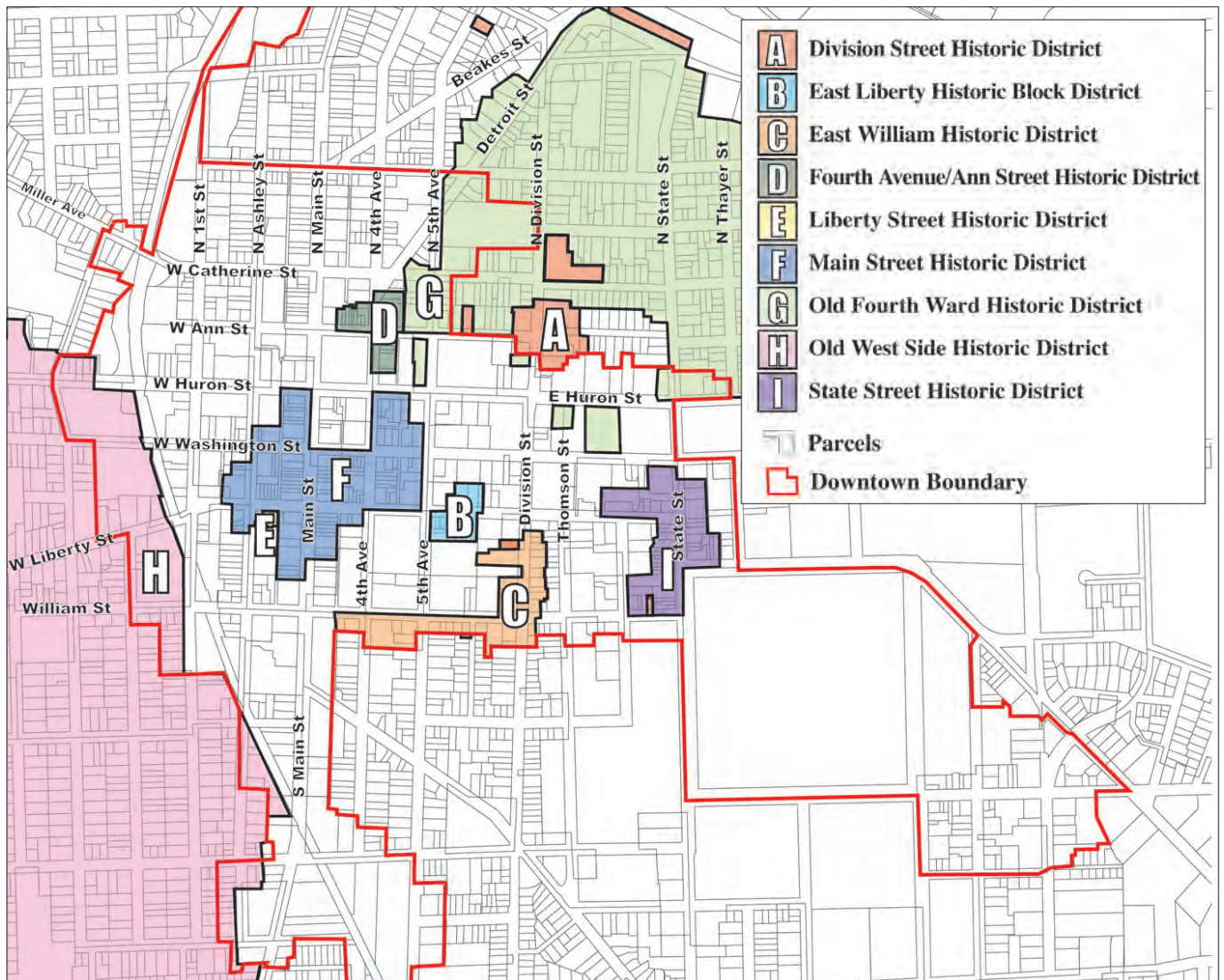

Downtown Ann Arbor includes all or part of nine historic districts. All parts of the East Liberty, East William, Fourth Avenue/Ann Street, Liberty Street, Main Street and State Street Historic Districts are within the boundary of downtown. Only a small part of the Old Fourth Ward, Old West Side and Division Street Historic Districts are within the boundary of downtown.

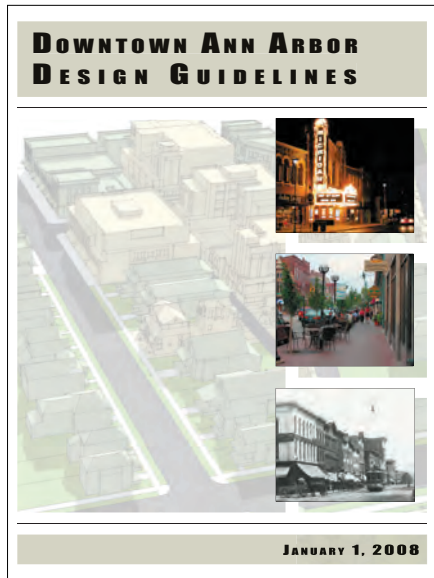

The Downtown Ann Arbor Design Guidelines provide extensive guidance for the design of new construction downtown and should be consulted when planning or reviewing a project on a downtown site within a historic district.



A small part of the Old Fourth Ward Historic District sits within the boundaries of Downtown Ann Arbor and is a mix of commercial and residential uses.

Relationship with the Downtown Ann Arbor Design Guidelines

A separate Downtown Ann Arbor Design Guidelines document provides extensive guidance for the design of new construction downtown and is applicable to new construction on a downtown site within a historic district.

Topic Areas. This chapter of the Historic District Design Guidelines provides additional guidance on the proper interpretation of the Downtown Ann Arbor Design Guidelines when working in historic commercial settings. The additional guidance is organized according to the topic areas within the downtown design guidelines. The general topic areas are:

- **Site Planning:** The arrangement of buildings and other features on individual sites and also the consideration of how a property will relate to its neighbors
- **Building Massing:** The overall form and composition of individual buildings
- **Building Elements:** The location and design of more detailed architectural elements such as doors and windows

Within each topic area, several specific design concepts are addressed. This chapter of the Historic District Design Guidelines provides information to assist with interpretation of the downtown design guidelines for each design concept.

Historic Context. New construction should be compatible with the context of its surrounding historic district. The Downtown Ann Arbor Design Guidelines also provide guidance for context-sensitive new construction in specific areas of downtown that have a unique character. These “character areas” are briefly noted in this chapter along with any special considerations associated with new construction in historic commercial settings within individual character areas.

Building in a historic district presents unique challenges and opportunities. Using both the Downtown Ann Arbor Design Guidelines and this Historic District Design Guidelines will assist with the development of creative design solutions for projects that are compatible with the context of downtown historic districts.

Site Planning for New Construction in Downtown Historic Districts

Site planning addresses the arrangement of buildings and other features on individual sites and also the consideration of how a property will relate to its neighbors. The site planning guidelines in Chapter 2 of the Downtown Ann Arbor Design Guidelines provide detailed guidance for the orientation of a building on its site, the location of service and parking areas, and the general organization of open spaces, including plazas and landscape features. Each of the site planning subsections within the downtown guidelines is referenced below. In some cases, additional guidance or interpretation for historic contexts is also provided.

Many downtown historic districts feature a continuous wall of building fronts at or near the sidewalk edge. This pattern should be continued as it provides for an active street edge which is appealing to pedestrians. In other historic downtown contexts, however, there is an existing pattern of historic residential front yards which should be maintained. Other key considerations for site planning include the continuity of historic circulation systems and the incorporation of environmental considerations such as access to sun and air.

Site Context in Downtown Historic Districts. Sites within each historic district feature differing setback, open space and parking patterns that contribute to the historic context. New construction should acknowledge the existing site context patterns in the historic district, the Section 3.0 Site Context guidelines in Chapter 2 of the downtown guidelines, and the site planning objectives and neighborhood building principles for the surrounding character area in Chapter 3 of the downtown guidelines.

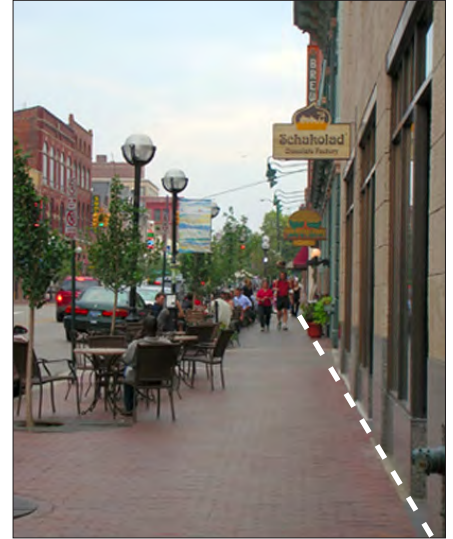

In the Main Street Historic District, buildings are generally located against the sidewalk edge, with architectural details and pedestrian amenities activating the street front.



Pedestrian Circulation Systems in Downtown Historic Districts. The sidewalks, paths and alleys between and within historic downtown properties provide pedestrian access to buildings, courtyards and plazas. New construction should provide a coordinated pedestrian circulation system that fits the character of the historic district.

In addition to the Section 2.0 Pedestrian Circulation Systems guidelines in Chapter 2 of the downtown guidelines, the following design principles are especially important to consider when planning pedestrian circulation systems in a historic district.

- Providing pedestrian connections to plazas, courtyards or other public spaces on adjacent historic properties
- Continuing and interconnecting pedestrian paths or mid-block connections through from surrounding historic properties



Deciduous landscaping supports sustainable site planning by providing summer shading while still allowing for solar access in the winter.

Sustainable Site Planning in Downtown Historic Districts. Site designs affect environmental considerations on both the site itself and on neighboring properties. Designs should support and encourage green building principles where they are compatible with the context of surrounding historic properties and the historic district.

The Section 3.0 Sustainability in Site Planning guidelines in Chapter 2 of the downtown guidelines are applicable to new construction in historic districts. However, the following considerations should also be made:

- Where sustainable site design would not be compatible with the site planning patterns on adjacent historic properties and the historic district, historic site planning considerations should take precedence.
- It is especially important for new buildings to be positioned in a way that does not significantly block views, breezes or solar access to or from open spaces on adjacent historic properties.

Setbacks and Alignment in Downtown Historic Districts. The prevailing setback and building alignment patterns are an important defining feature of historic districts and have a significant impact on the pedestrian experience. The setbacks and alignment of new buildings should respect the setback and alignment pattern of surrounding historic properties and the historic district to support a cohesive pedestrian experience and maintain the character of the historic district.

Basic setback and alignment patterns for downtown Ann Arbor are established in the zoning code. The Section 4.0 Setbacks and Alignment guidelines in Chapter 2 of the downtown guidelines are also applicable to new construction in historic districts. When working in a historic district, it is also important to consider the following:

- Maintaining the setback and alignment pattern seen on surrounding historic properties should take precedence over the setback and alignment pattern of any surrounding properties that are not historic.
- Alternative building orientations should generally not be considered for new construction in historic districts.

Open Space in Downtown Historic Districts. Open space on private developments should continue the existing open space pattern on surrounding historic properties and in the historic district and should be planned to activate the street and enhance the pedestrian experience. Open spaces such as landscaped yards, plazas, courtyards, patios and terraces should be provided at sidewalk level; sunken open spaces are not appropriate.

The Section 5.0 Open Space design guidelines in Chapter 2 of the downtown guidelines are applicable to new construction in historic districts. However, the following considerations should also be made:

- In a historic district, it is especially inappropriate to locate an open space such as a plaza at the corner of a property unless such a space is indicated in an area plan or the open space would be located at a major intersection.
- In historic commercial districts where buildings are built directly adjacent to the sidewalk, open spaces should not be located on the street frontage as they will disrupt this pattern.



As in most historic commercial settings, historic buildings in the Main Street Historic District are aligned with each other, oriented to the street and built directly against the sidewalk. New construction should maintain this pattern where it exists.



In some downtown historic districts such as the East Liberty Street Historic District, historic residential structures are set back a modest distance from the sidewalk. New construction should maintain this pattern where it exists.



It is especially important to screen surface parking areas from the street when working in a historic commercial setting.

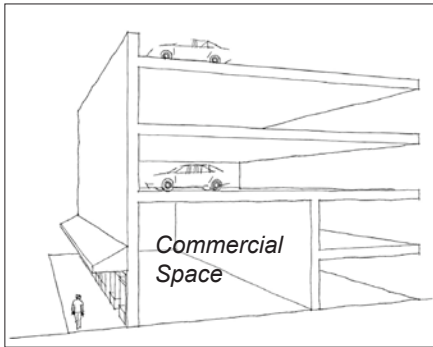

In historic settings with a pattern of ground floor commercial uses, it is especially appropriate to incorporate such uses at the street level of a new parking structure.

Surface Parking and Driveways in Downtown Historic Districts. Many historic commercial settings in downtown Ann Arbor pre-date the automobile era. As a result, sensitive parking lot and driveway designs are especially important when working in a historic district. When possible, surface parking should not be exposed to the street and should provide for an active pedestrian-friendly street front.

The Section 6.0 Surface Parking and Driveways guidelines in Chapter 2 of the downtown guidelines are applicable to new construction in historic districts. However, the following considerations merit special emphasis:

- It is appropriate to access parking areas from historic alleys, where present
- It is especially important to screen surface parking adjacent to historic commercial streets
- “Shared” parking should also be planned so that several businesses can utilize one parking area as opposed to introducing random, multiple lots

Parking Structures in Downtown Historic Districts. When building a new parking structure in a historic commercial setting, it is important to consider its compatibility with adjacent historic structures and the surrounding historic district. The primary goals are to maintain a pedestrian friendly street-front, minimize visual impacts and acknowledge surrounding historic scale and proportions.

The Section 7.0 Parking Structures guidelines in Chapter 2 of the downtown guidelines are applicable to new construction in historic districts. However, the following considerations should also be made:

- In historic settings with a pattern of ground floor commercial uses, it is appropriate to incorporate such uses at the street level of a new parking structure
- The facade of a new parking structure should incorporate design elements seen on adjacent historic buildings

Building Massing for New Construction in Downtown Historic Districts

Building massing principles address the overall size and shape of an individual structure. The base zoning for downtown Ann Arbor addresses elements of building massing including floor area ratio (FAR), offsets and maximum diagonals. The building massing guidelines in Chapter 2 of the Downtown Ann Arbor Design Guidelines supplement the base zoning with additional direction on building height, modules, articulation and roof form. Each of the building massing subsections within the downtown guidelines is referenced below. In some cases, additional guidance or interpretation for historic contexts is also provided.

Building massing should fit with existing historic patterns. Existing historic patterns and traditions in building massing include varied heights, articulated masses, visually interesting skylines and pedestrian-scaled street fronts. Building massing should continue to provide a variety of pedestrian-friendly scales and visually appealing masses. Buildings should not be immense in scale or greatly contrast with the existing scale on the block or in the surrounding historic district.



Although building massing can be highly varied in some historic commercial settings such as the Main Street Historic District, new buildings should fit within the general historic pattern and incorporate elements that increase the visual compatibility of their massing.



Taller historic structures in downtown Ann Arbor respect the surrounding streetwall pattern. Taller portions are seen to be compatible with smaller buildings in the area because first floors are articulated to express this traditional scale.

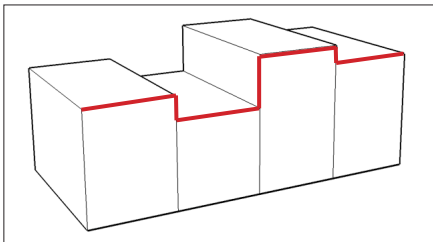

In historic settings with varied building heights, the street front of a new larger building should be varied in height to reflect the traditional pattern.

Building Height in Downtown Historic Districts. The variety of historic building heights that exists in downtown Ann Arbor helps to define the character of the area. The city’s zoning code defines base regulations for building height, and focuses on establishing a lower scale at the street edge, with taller portions of buildings stepping back into the property. While there is an overall traditional height of buildings in the downtown, variation in the profile or parapet lines does occur. This variety helps give scale to the street as well as to the building itself. New construction in historic commercial settings may continue Ann Arbor’s tradition of height variation. However, if a new building is taller than surrounding historic structures, the taller portion of the building should be stepped back significantly from the streetwall portion of the building.

The Section 8.0 Building Height guidelines in Chapter 2 of the downtown guidelines are applicable to new construction in historic districts. The following considerations from the downtown guidelines merit special emphasis:

- The first floor height of a new building should reflect traditional first floor heights seen on adjacent historic commercial structures (often much taller than the second floor height)
- In historic settings with varied building heights, the street front of a new larger building should be varied in height to reflect the traditional pattern
- Any taller portions of a new building should be located to minimize shading and looming effects on adjacent historic properties

Building Modules and Articulation in Downtown Historic Districts. The character of downtown Ann Arbor relies upon a human scale that is partly expressed through a variation in the height, design and articulation of building modules. Expressing traditional lot-width patterns is a primary consideration in the composition of building modules and their articulation. Horizontal and vertical building articulation should respect both traditional patterns along the street and the underlying historic lot width pattern.

The Section 9.0 Building Modules and Articulation guidelines in Chapter 2 of the downtown guidelines are applicable to new construction in historic districts with special emphasis on the following considerations:

- New buildings should be broken down into modules that reflect the massing of adjacent historic structures
- New buildings should be articulated and divided into vertical modules to reflect the underlying historic lot pattern
- New commercial and mixed-use buildings should incorporate a base, middle and cap facade composition to reflect historic patterns and convey a sense of human scale.

Human Scale in Downtown Historic Districts. A sense of human scale is achieved when one can reasonably interpret the size of a building by comparing features of its design to comparable elements in one’s experience. Maintaining a sense of human scale is a key objective for all of downtown Ann Arbor and is especially important in historic districts.

All of the design guidelines that apply to new construction in historic commercial settings seek to establish and maintain a sense of human scale. The Section 10.0 Human Scale guidelines in Chapter 2 of the downtown guidelines address human scale in a more specific way and should be applied to new construction in historic districts.

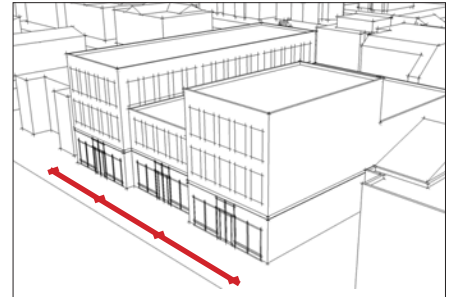
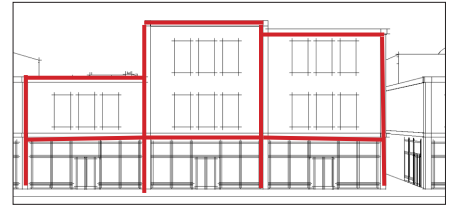

A building that occupies more than one traditional lot should be articulated and divided into vertical modules that reflect underlying historic lot widths. This helps a larger building fit into the scale of a historic commercial setting.

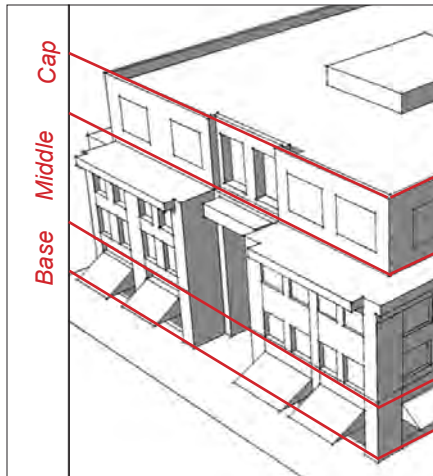
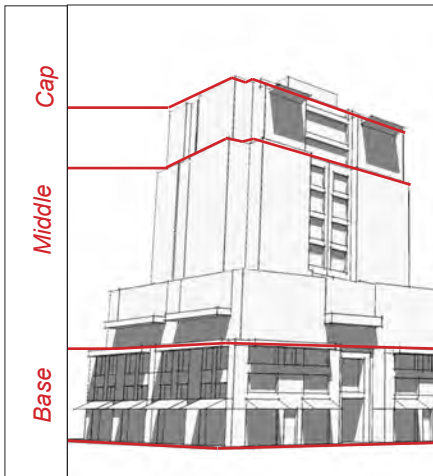

Commercial and mixed-use buildings should be designed to reflect the base, middle and cap facade composition that is traditionally seen in downtown Ann Arbor.



Historic commercial buildings such as those in the Main Street Historic District usually have flat roofs.

Roof Form in Downtown Historic Districts. Most historic commercial buildings have flat roofs, but a hip roof form or other shape is sometimes used to establish a cap. The roof forms of new buildings in historic commercial settings should reflect the pattern of roof forms seen on adjacent historic structures and in the surrounding historic district.

The Section 11.0 Roof Form guidelines in Chapter 2 of the downtown guidelines are applicable to new construction in historic districts. The following considerations from the downtown guidelines merit special emphasis:

- Roof forms used in new construction should reflect roof forms seen on historic structures in the district
- Sloped roof forms are appropriate for new construction within mixed-use and multi-family residential areas around the edges of downtown, adjacent to predominantly residential neighborhoods

Sustainable Building Massing in Downtown Historic Districts. The orientation of building massing should take advantage of solar access for both passive and active strategies of daylighting and solar energy collection.

The Section 13.0 Sustainability in Building Massing guidelines in Chapter 2 of the downtown guidelines are applicable to new construction in historic districts. Special consideration should be given to ensuring that new construction does not shade south facing facades of adjacent historic buildings during winter months.

Building Elements for New Construction in Downtown Historic Districts

Architectural details, materials and other components can be used to convey scale and provide visual interest, and will influence the degree to which a new building is compatible with surrounding historic context and contributes to the urban fabric. The Building Element Design Guidelines in Chapter 2 of the Downtown Ann Arbor Design Guidelines are intended to promote development that is compatible with existing design contexts, but not to dictate a specific style or design theme. Each of the building element subsections within the downtown guidelines is referenced below. In some cases, additional guidance or interpretation for historic contexts is also provided.

Quality and creativity are most clearly expressed and experienced at a detailed scale of design. Creative, contemporary and environmentally oriented building element design is encouraged for new construction in historic commercial settings.

Windows in Downtown Historic Districts. In historic commercial settings, upper story windows often appear to align with others in the block, and establish a rhythm, or pattern of solid and void that visually links buildings along the street. Window design and placement should help to maintain established patterns along a historic block.

The Section 13.0 Windows guidelines in Chapter 2 of the downtown guidelines are applicable to new construction in historic districts. The following considerations from the downtown guidelines merit special emphasis:

- Although creative and contemporary window designs are encouraged, the apparent solid-to-void ratios seen on the primary facades of adjacent historic structures should be maintained.
- Maintain the general alignment of window sills, moldings or related features seen on adjacent historic structures
- Storefront windows should be provided to reflect the surrounding historic commercial context

Entries in Downtown Historic Districts. The repetition of primary building entries along a street reinforces historic patterns and invites pedestrian activity. The spacing of entries can activate the streetscape and pedestrian experience. Entrances to new buildings should be clearly defined and should be designed to enhance the street level experience and reflect the rhythm of historic entrances along the block.

The Section 14.0 Entries guidelines in Chapter 2 of the downtown guidelines are applicable to new construction in historic districts with emphasis on the following considerations:

- Sunken or below grade entries are inappropriate in historic commercial settings
- Where a pattern of recessed entries exists on adjacent historic structures or in the surrounding historic district, it is appropriate to continue this pattern in historic commercial settings.



Although creative and contemporary designs are encouraged, the apparent solid-to-void ratios seen on the primary facades of adjacent historic structures should be maintained.



Arrange windows in patterns that will reinforce the rhythm and alignment of windows on adjacent historic structures and in the surrounding historic district.

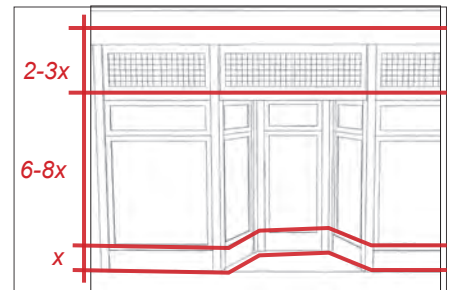

Storefront windows should be provided to reflect the surrounding historic commercial context. Traditional storefronts are often proportioned as shown above.



The repetition of entries along a street reinforces historic patterns and contributes to pedestrian activity.

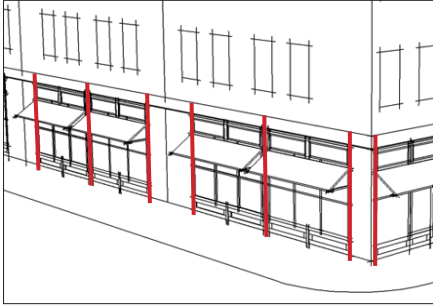

When using canopies on new construction in historic commercial settings, special emphasis should be placed on sizing and positioning canopies to reflect the traditional storefront rhythm seen on adjacent historic structures and in the surrounding historic district.



Historic building materials often convey a sense of human scale and visual interest. The use of historic building materials is encouraged in new construction, but creative and contemporary applications are appropriate.

Canopies and Awnings in Downtown Historic Districts. Canopies and awnings provide protection and shade and can be used to define pedestrian accessible features of buildings as well as provide a sense of depth, color and visual interest which can enhance the streetscape. When canopies and awnings are used, they should define building entries, reflect the pattern of canopies and awnings seen on adjacent historic structures and complement the design and character of a building and its street front.

The Section 15.0 Canopies and Awnings guidelines in Chapter 2 of the downtown guidelines are applicable to new construction in historic districts. Special emphasis should be placed on sizing and positioning canopies to reflect the traditional storefront rhythm seen on adjacent historic structures and in the surrounding historic district.

Materials in Downtown Historic Districts. Exterior building materials can be used to convey design quality and provide a sense of scale and texture. Choose building materials that are compatible with materials traditionally seen in the surrounding historic context. Material choices and placement should also reinforce the guidelines for building massing and elements.

The Section 16.0 Materials guidelines in Chapter 2 of the downtown guidelines are applicable to new construction in historic districts with special emphasis on the following considerations:

- When working in historic districts, it is inappropriate to use large panelized products or apply materials to create extensive featureless surfaces
- The use of historic building materials is encouraged in new construction but creative and contemporary applications are appropriate

Sustainable Building Elements in Downtown Historic Districts. Individual building elements and materials play an integral role in the systems (environmental and otherwise) of the building as a whole and of the building with its site. Building elements should be chosen and arranged to maximize the efficiency of the building’s performance without compromising its compatibility with adjacent historic structures and the surrounding historic district.

The Section 17.0 Sustainability in Building Elements guidelines in Chapter 2 of the downtown guidelines are applicable to new construction in historic districts. Where concern may exist regarding the compatibility of sustainable building elements and materials with surrounding historic context, historic compatibility should generally be the most important consideration.

Downtown Character Areas

The Downtown Ann Arbor Design Guidelines provide guidance for context-sensitive new construction in specific areas of downtown that have a unique character. Several of these unique character areas include historic districts. Compatibility with the surrounding historic district is the primary consideration for new construction in historic commercial settings. However, the guidelines in Chapter 3: Design Guidelines for Character Areas within the Downtown Ann Arbor Design Guidelines are applicable to new construction in downtown historic districts.

Each downtown character area that includes all or part of a historic district is briefly noted below as are any special considerations relating to new construction in the enclosed district. The downtown design guidelines for character areas that do not include historic districts are not applicable to new construction on sites within downtown historic districts. A map showing character area boundaries is included in the downtown design guidelines document.

State Street Character Area. This character area frames the northwest corner of the central campus of the University of Michigan and defines the edge of the commercial core. State Street forms a north-south spine for this area, while East Washington and East Liberty serve as connectors to the Main Street area to the west. The Chapter 3 guidelines for the State Street Character Area in the downtown guidelines are applicable to new construction in the State Street Historic District and a small non-contiguous section of the Division Street Historic District which are within this character area.

Along State Street itself, many buildings are of historic significance and retain features of traditional commercial buildings with storefronts aligned at the sidewalk edge. These first floor levels are more transparent than those of floors above, and this distinction helps to create a horizontal line along the street that establishes a one-story scale held in common among most properties. This contributes to a sense of visual continuity that unifies the street scene.

Within the State Street Historic District portion of the overall character area, preservation of the integrity of individual contributing resources and of the overall historic character of the area is a primary objective. Many of the buildings are rated as contributors and their preservation is essential, although additions may be considered.

With respect to new construction within the historic district, development is desired, when it is compatible with the historic context.



The historic Nickels Arcade is a unique feature within the State Street Character area and historic district. Such mid-block connections encourage pedestrian activity.



New construction within the State Street Character Area and historic district should reflect the area's traditional two and three-story parapet block scale.



The Kempf house in the Division Street Historic District illustrates the residential scale that exists in some parts of the Liberty/Division Character Area.



The portions of the Old Fourth Ward Historic District that are within the East Huron Character Area include churches and other civic structures.

Liberty/Division Character Area. This area is centered on a short section of Liberty and Division Streets, beginning at the point where they intersect and extending south to William, east to Thompson and west to Fifth. While this area is a part of the downtown commercial zone district, several streets retain a smaller scaled residential character. Both the East Liberty Street Historic District and the East William Street Historic District are enclosed by this character area. A small, non-contiguous section of the Division Street Historic District is also within this character area. The Chapter 3 guidelines for the Liberty/Division Character Area in the downtown guidelines are applicable to new construction in each of the enclosed historic districts.

Preservation of the integrity of existing historic resources is a high priority in this character area. The application of zoning premiums that may increase building mass should be used with care. In some historic contexts within this character area, most structures were originally built as residences and are set back from the street. New construction in these areas should continue the setback and front yard patterns seen on adjacent historic properties along the block and should maintain the traditional scale and rhythm of the residential building type. The use of porches or similar one-story elements to define primary entrances and maintain residential scale is encouraged.

East Huron Character Area. The East Huron Character Area runs along Huron Street from State Street on the east to North Fifth Avenue on the west. Several small sections of the Old Fourth Ward Historic District are within this character area. The Chapter 3 guidelines for the East Huron Character Area in the downtown guidelines are applicable to these sections of the historic district.

The sections of the historic district that are within the East Huron Character Area include churches and other civic structures that were designed “in the round,” with substantial open space between each building and the property lines. This pattern of free-standing buildings is a distinctive feature which should be continued. For this reason, increased front yard setbacks with large green areas in front is a part of the vision. Even new structures that do not house institutional functions should continue this design tradition in this area, with substantial amounts of open space in front, and a “presence” in design that signals a sense of connection with the community at large. Signature building elements that give landmark qualities to properties are also appropriate. Creative, contemporary interpretations of corner towers, decorative parapet lines, and other special details are examples.

Main Street Character Area. The Main Street Character Area includes approximately fourteen city blocks, with the central spine along Main Street itself. The center of the character area is the Main Street Historic District with a high concentration of contributing historic resources. The Chapter 3 guidelines for the Main Street Character Area in the downtown guidelines are applicable to new construction in the historic district.

The historic district includes many traditional commercial buildings. These buildings are mostly one to four stories in height but some are taller. Regardless of height, each of these buildings shares some basic features with its neighbors. Storefronts align at the sidewalk edge, and the first floor is primarily transparent, providing views to goods and activities inside. The heights of most first floors are similar, which also contributes to a sense of a similar scale and establishes a horizontal line along the street edge that strengthens the sense of visual continuity for the area. This is a key design principle to be employed with new construction, especially that which may be built to greater heights.

Architectural details also provide interest. Historic buildings in this character area include durable, high quality, architectural details from a variety of styles and periods. Moldings, trim elements and window surrounds that establish substantial shadow lines help to provide visual interest and convey a sense of scale. This is a tradition that should be continued when planning new construction in the historic district.

Maintaining the traditional rhythm of storefronts along the street edge is also important. While there is some variety in their widths, most storefronts reflect the historic lot dimension. Even larger buildings which occupy several lots are divided into modules that reflect this dimension. It is important that new construction maintain this rhythm. This rhythm of lot widths is also reflected in parapet lines. Because building heights vary with the lots, this helps to reduce the sense of mass along the street edge and contributes to its visual interest. This variation in parapet lines should be continued, especially for any new construction that may be taller than the surrounding historic context.



The well-defined street edge that exists in the Main Street Character area and historic district should be maintained.



The established two- to three-story streetwall height within most parts of the Main Street character area and historic district should be maintained.



The residential landscape in most parts of Kerrytown should be enhanced and maintained.



A small section of the Old Fourth Ward Historic District that is within the Kerrytown Character Area illustrates the modest scale that is typical of the area.

Kerrytown Character Area. This area is a special part of downtown that is cherished for its mix of small scale commercial buildings and single family houses. Many structures that originally were residential in use are now adapted to other purposes. The Fourth Avenue/Ann Street Historic District and a small section of the Old Fourth Ward Historic District are within this character area. The Chapter 3 guidelines for the Kerrytown Character Area in the downtown guidelines are applicable to the enclosed sections of historic district.

Retaining traditional buildings is a priority in this area and therefore, where additional building area is needed, constructing an addition is preferred to new construction. Development should appear to be low in scale within this historic district. Even though moderate increases in density are anticipated, this should be accomplished by dividing larger buildings into smaller modules that reflect traditional building scale.

Any new building or addition that will be constructed near existing, small scale, residential type buildings should in some way reflect that scale. Stepping a portion of the building down in height along these edges, or increasing building setbacks to provide more separation, will be important. Using building forms that reflect the traditional single family building type is also to be encouraged. Larger structures may use these shapes and be subdivided into modules that provide a respectful transition in scale.

First Street Character Area. The First Street Character Area is a large area, running north-south along the western edge of downtown. The eastern edge of the Old West Side Historic District lies within this character area. The Chapter 3 guidelines for the First Street Character Area in the downtown guidelines are applicable in this area of the historic district. These include guidelines intended to promote development of greenspace along the industrial corridor.

Many buildings within the historic district were constructed for industrial uses, and their architectural design reflects this heritage. Noteworthy building features include masonry walls punctuated with industrial sash windows. New construction that draws upon the industrial heritage in creative contemporary ways is encouraged. Structures that have tall first floor heights are a part of this tradition as well.

APPENDIX A: GLOSSARY OF TERMS

Apron: A plain or decorated piece of trim found directly below the stool of a window

Arch: A curved and sometimes pointed structural member used to span an opening

Areaway: A sunken area around a basement window or doorway, or mechanical air intake

Attic: The room or space in the roof of a building

Awning Window: A window that is hinged at the top and swings outward

Balcony: A railed projecting platform found above ground level on a building

Baluster: One of a series of short pillars or other uprights that support a handrail or coping

Balustrade: A series of balusters connected on top by a coping or a handrail and sometimes on the bottom by a bottom rail; used on staircases, balconies, porches, and the like

Base: The lowest part of a column

Basement: The story below the main floor; may be partially or totally below ground level

Bay: A space protruding from the exterior wall that contains a bay window

Bay Window: A projecting window with an angular plan

Bracket: A projecting support used under cornices, eaves, balconies, or windows to provide structural or visual support

Brick: A usually rectangular building or paving unit made of fired clay

Canopy: A projection over a niche or doorway; often decorative or decorated

Capital: The uppermost part, or head, of a column or pilaster

Casement: A hinged window that opens horizontally like a door

Casing: The finished visible framework around a door or window

Cement Mortar: A mixture of cement, lime, sand, or other aggregates with water; used in plastering and bricklaying

Cladding: Material used for covering the exterior of a building, such as clapboards or wood shingles.

Clapboard: A thin board, thinner at one edge than the other, laid horizontally and with edges overlapping on a wooden-framed building

Column: A round, vertical support. In classical architecture the column has three parts, base, shaft, and capital

Concrete: Made by mixing cement or mortar with water and various aggregates such as sand, gravel, or pebbles

Concrete Block: A hollow or solid rectangular block made of Portland cement, aggregates, and water; used in the construction of walls, foundations, and piers, etc.

Coping: The protective uppermost course of a wall or parapet

Corner Boards: Boards placed at the corners of exterior walls to provide a neater appearance and to protect the ends of the wood siding

Cornice: In classical architecture the upper, projecting section of an entablature; also the projecting ornamental molding along the top of a building or a wall

Course: A horizontal row of stones, bricks, or block in a wall

Dentil: A small rectangular block used in a series to form a molding below the cornice

Dormer: A vertically set window on a sloping roof; also the roofed structure housing such a window

Double Hung Window: A window of two (or more) sash, or glazed frames, set in vertically grooved frames and capable of being raised or lowered independently of each other

Downspout: A pipe that carries water from the gutters to the ground or sewer connection

Eaves: The lower edge of a roof that projects beyond the building wall

Ell: An extension that is at right angles to the length of the building

Entablature: The horizontal beam-like member supported by columns containing three parts: the lower architrave, the middle frieze, and the upper cornice.

Fascia: The flat area or board covering the ends of roof rafters

Fenestration: The arrangement of windows and other exterior openings on a building

Fixed Sash: A window, or part of a window, that does not open

Flashing: Pieces of metal used around wall and roof junctions and angles as a means of preventing leaks

Flat Roof: A roof that has only enough pitch so that water can drain

Gable: The triangular upper part of a wall under the end of a ridged roof, or a wall rising above the end of a ridged roof

Gable Roof: A sloping (ridged) roof that terminates at one or both ends in a gable. A roof formed by two pitched roof surfaces

Gambrel Roof: A roof having a double slope on two sides of a building. The most common example is a barn roof

Gazebo: An outdoor pavilion or summer house popular for lawns and gardens of rural houses in the Victorian era

Gutter: A channel of wood or metal running along the eaves of the house; used for catching and carrying off water

Half-timbered: Descriptive of 16th and 17th century houses built with timber framing with the spaces filled in with plaster or masonry. This style of building was imitated in the 19th and early 20th centuries with the Tudor Revival style

Hip Roof: A roof formed by four pitched roof surfaces

Hood: A protective and sometimes decorative cover over doors or windows

Hopper Window: A window that is hinged on the bottom and swings inward

Keystone: The central stone of an arch

Lattice: Open work produced by interlacing of laths or other thin strips used as screening, especially in the base of the porch

Leaded Glass Window: A window composed of pieces of glass that are held in place with lead strips; the glass can be clear, colored, or stained

Lintel: The piece of timber, stone, or metal that spans an opening and supports the weight above it

Mansard Roof: A roof having two slopes on all four sides; the lower slope is much steeper than the upper

Mullion: A large vertical member separating two casements or coupled windows or doors

Muntin: One of the thin strips of wood used for holding panes of glass within a window

Newel Post: The post supporting the handrail at the top and bottom of a stairway

Parapet: A low wall or protective railing, usually used around the edge of a roof or around a balcony

Patio: A usually paved and shaded area adjoining or enclosed by the walls of a house

Pediment: A triangular section framed by a horizontal molding on its base and two sloping moldings on each side

Pilaster: A rectangular column or shallow pier attached to a wall

Porch: A covered entrance or semi-enclosed space projecting from the façade of a building. May be open sided, screened, or glass enclosed

Portland Cement: A hydraulic cement binder for concrete

Pyramidal Hipped Roof: A pyramid-shaped roof with four sides of equal slope and shape

Rafters: The sloping members of a roof upon which the roof covering is placed

Retaining Wall: A braced or freestanding wall that bears against an earthen backing

Ridge: The horizontal line formed when two roof surfaces meet

Sash: The framework of a window into which panes are set, usually the moveable part of a window

Screen Door: A door intended to allow ventilation but exclude insects, usually consisting of a lightweight frame and screening

Shed Roof: A roof consisting of one inclined plane

Side Light: A usually long fixed sash located beside a door or window

Sliding Window: A window that moves horizontally in grooves, on strips, or between runners

Stool: The interior casing or molded piece running along the base of a window and contacting the bottom rail on the inside of a building. Also called the interior sill.

Stucco: An exterior wall covering consisting of a mixture of Portland cement, sand, lime, and water

Terra Cotta: A fine-grained fired clay product used ornamentally on the exterior of buildings; may be glazed or unglazed, molded or carved; usually brownish red in color, but may also be found in tints of gray, white, and bronze

Transom Window: A small window or series of panes above a door, or above a casement or double hung window, or above a storefront display window

Valley: The depressed angle formed at the meeting point of two roof slopes

Wing: A parallel extension to a building

APPENDIX B: WINDOW ELEMENT MEASUREMENTS WORKSHEET

Window Specifications

Refer to the criteria below for proper measurements. For cases of necessary replacement, the Historic District Commission requires that a new window meet *all* of the following criteria:

The viewable profile dimensions of the exterior rails and stiles are within 1/4" of the original.

Sash Face	Existing	Proposed
Distance	_____	_____

The distance from sash face to back of casing is within 1/8" of the original dimensions, but not less than 3/8" total.

Profiles	Existing	Proposed
Distance	_____	_____

The casing width and thickness (including drip cap, if applicable) are within 1/8" of the original.

Casing Thickness	Existing	Proposed
Distance	_____	_____

Casing Width	Existing	Proposed
Distance	_____	_____

The sill is similar in pitch to the original, extends to the outer edge of casing, and has a thickness within 1/8" of the original.

Sill Pitch	Existing	Proposed
Distance	_____	_____

Sill Thickness	Existing	Proposed
Distance	_____	_____

Head Detail

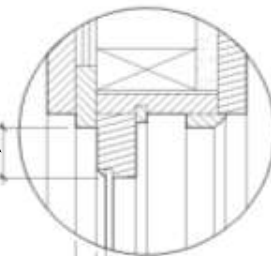

Jamb Detail

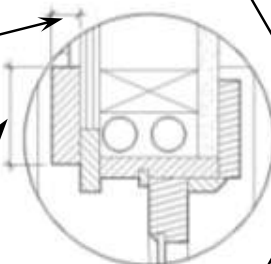

Sill Detail

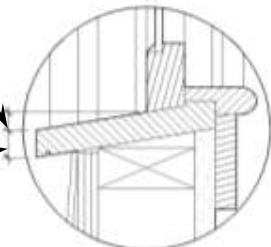

The window unit type matches the original (double-hung, casement, etc.)

Window Type
Do the proposed windows types match the existing types?
Yes _____ No _____

The number and location of muntins matches the original.

Muntins
Does the count and arrangement of muntins match the original?
Yes _____ No _____

The distance from glass surface to exterior surface of muntin, rail and stile is at least 3/8"; AND the exterior surface of the unit's glass insets in the sash is within 1/8" of the original.

Glass Inset	Existing	Proposed
Distance	_____	_____

The glass size remains within 90% of the original in both directions.

Glass Size	Existing	Proposed
Height	_____	_____
Width	_____	_____

Refer to Window Resource List for those individuals and companies who may be equipped to aid in the window evaluation/repair.

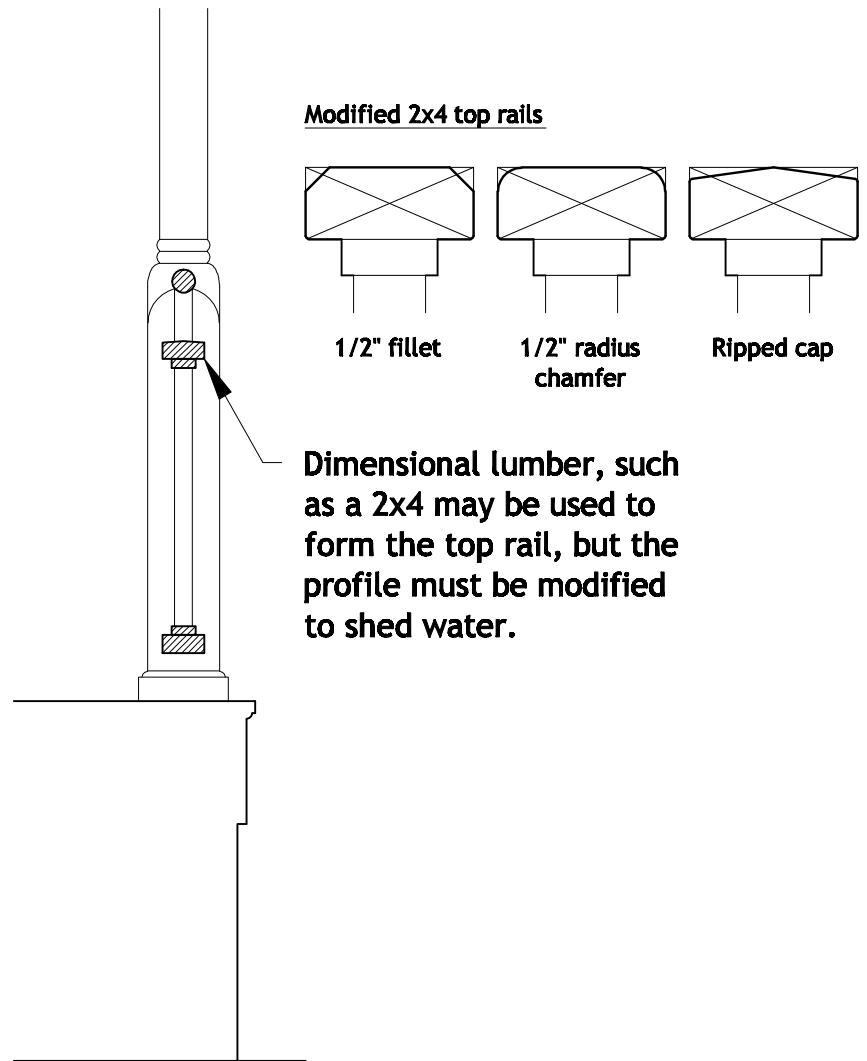

Modified 2x4 top rails

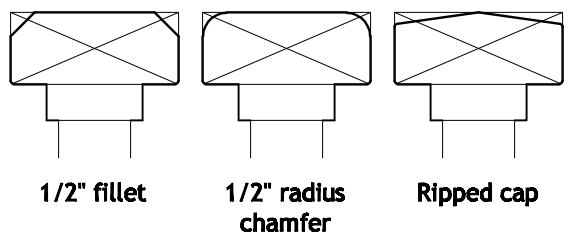

Dimensional lumber, such as a 2x4 may be used to form the top rail, but the profile must be modified to shed water.

Rail Section

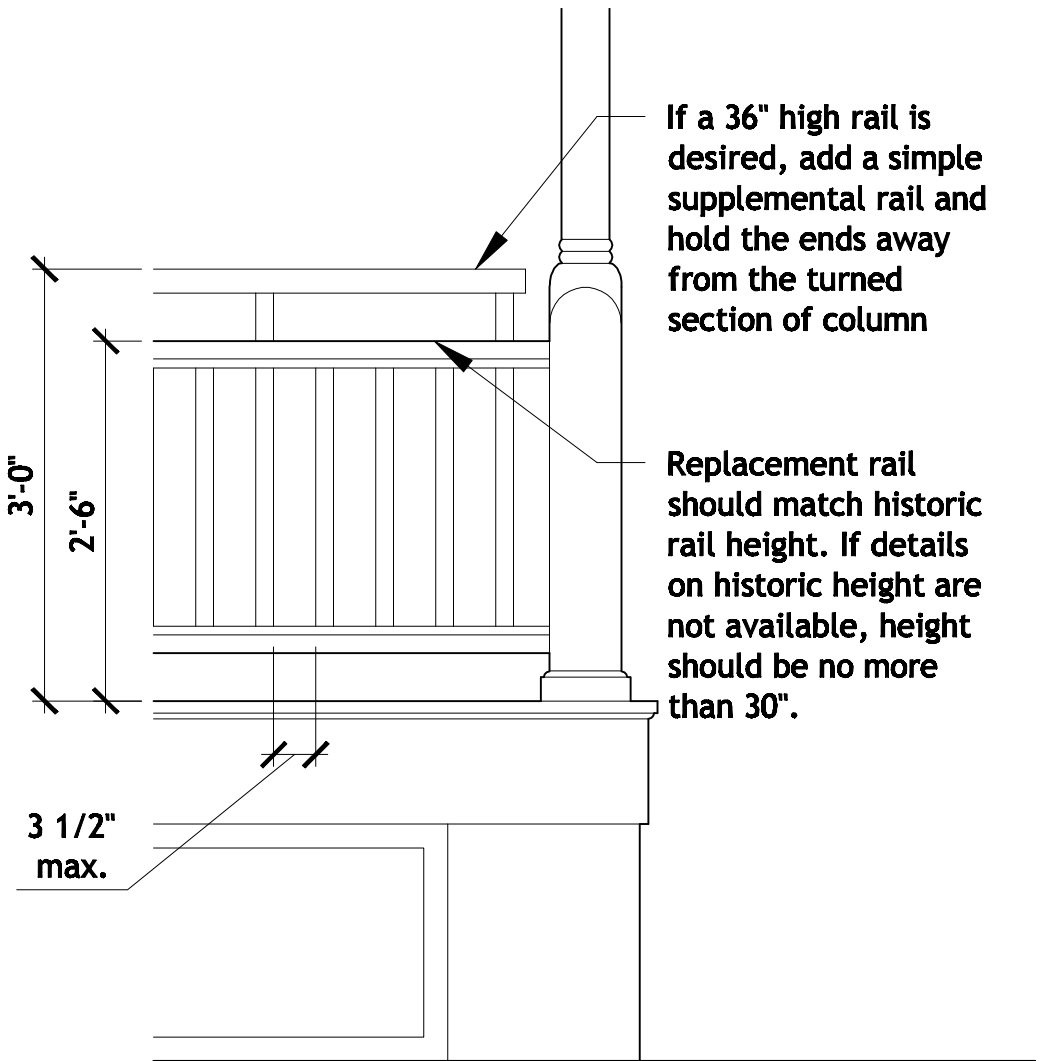

If a 36" high rail is desired, add a simple supplemental rail and hold the ends away from the turned section of column

Replacement rail should match historic rail height. If details on historic height are not available, height should be no more than 30".

Rail Elevation

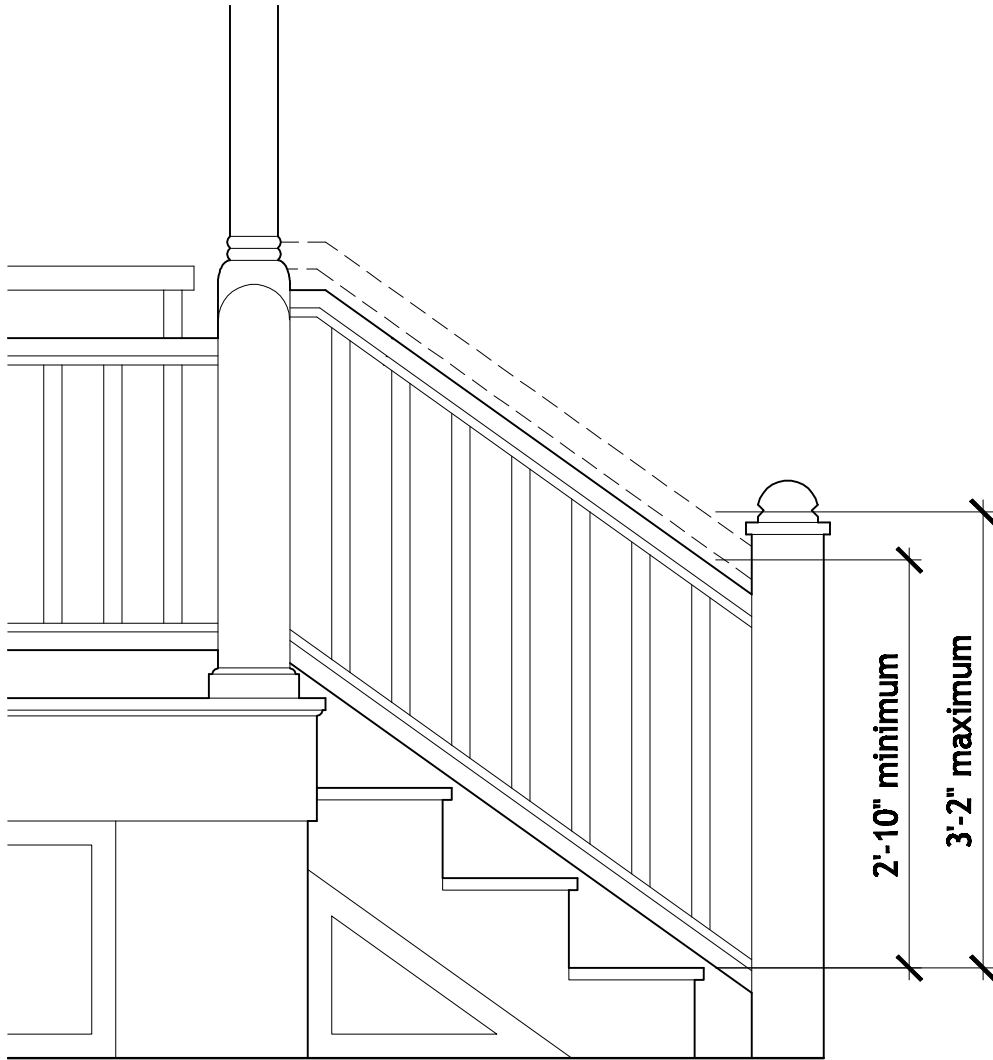

Stair & Rail Elevation

Graspable handrail options

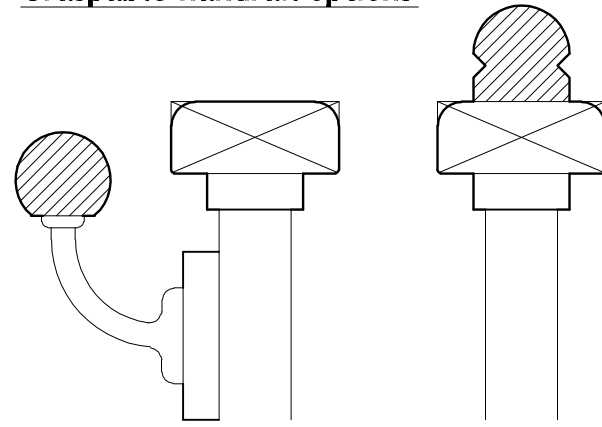

**Side
mounted**

**Top
mounted**

**City of Ann Arbor
Historic District Commission
Handrail guidelines**

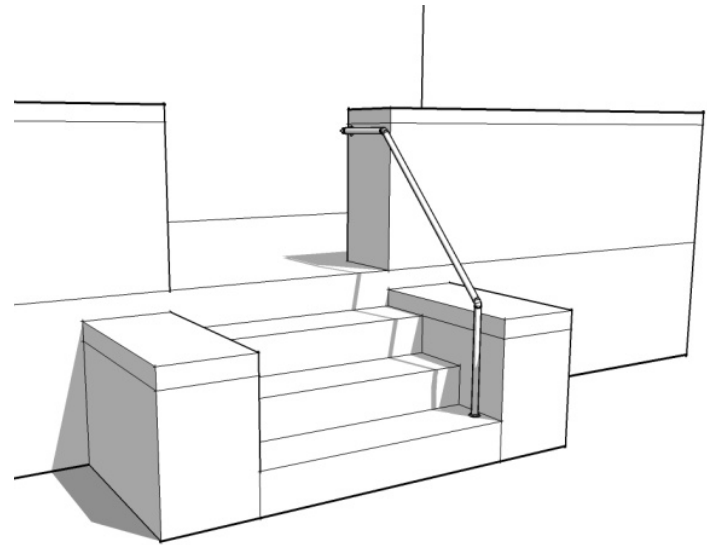
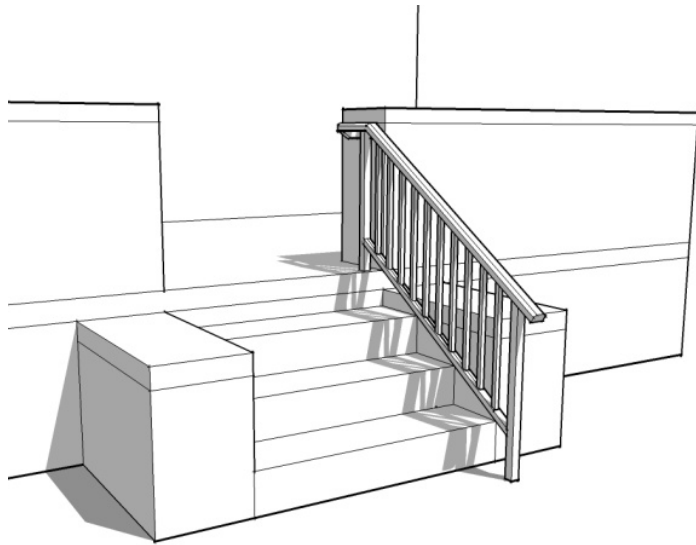
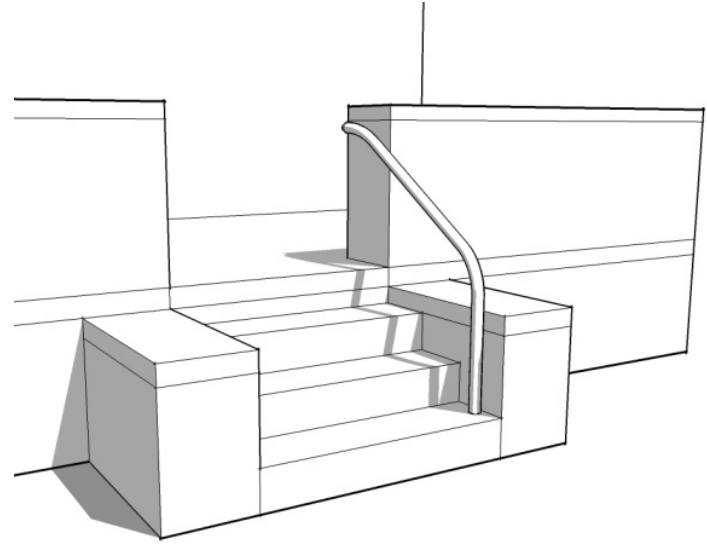
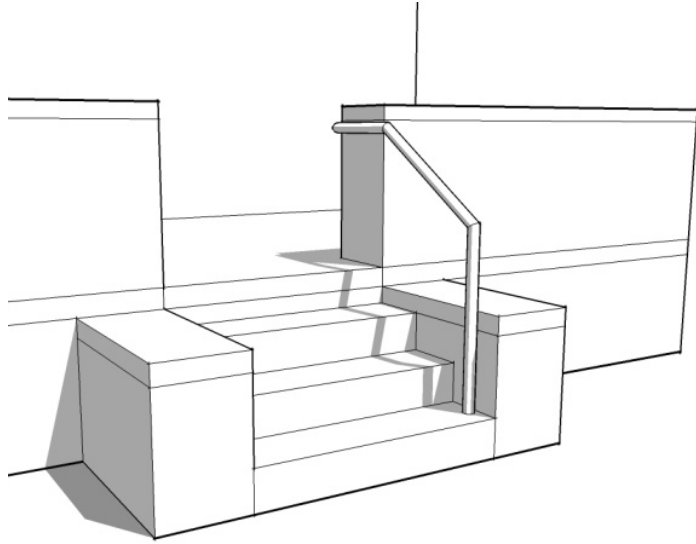

Ann Arbor Historic District Sign Guidelines

For any property in a historic district, all signs must be approved by the Historic District Commission.

- All new signs must receive a Certificate of Appropriateness from the Historic District Commission.
- Some signs can be administratively approved by staff, on behalf of the Commission, if they are replacing a sign with one of the same or a smaller size and in the same location.

In order to be approved, signs must meet several requirements:

- If the building is masonry, signs must be mounted in mortar joints, NOT through masonry units, such as brick or stone.
- New business signs may NOT be internally illuminated.
 - If an existing business wants to reface their internally illuminated box sign, they may do so and keep it lit. If the business changes, the new sign may NOT be lit from within. The box sign may be refaced, but it cannot be turned on. Illumination must come from an external source.

Acceptable sign lighting:

- Simple, low-key designs that do not detract from the building. These designs include gooseneck lamps, LED light strips, small spotlights.
- New wiring must go through the masonry joints, not the masonry units.
- Sign lighting is usually a staff approval that does not require review by the Commission.

Pedestrian scale signs:

These signs are intended to help pedestrians find a business from the sidewalk. They are usually not a business's primary signage. Pedestrian scale signs should be:

- Located near the business's entry, at least 8' from the ground on the first floor.
- Mounted on an arm or arms or hung from a bracket.
- Aligned with similar signs on the block.
- Sized not to exceed 4.5 square feet per side. This is roughly a 28" diameter circle, or 25" square. Odd shapes are welcomed and will be reviewed on a case by case basis.

Banners:

Banners, pennants, and similar temporary signs that are often made of fabric or vinyl are not appropriate in Ann Arbor's local historic districts.

All signs must also meet the sign code: Chapter 61 of the Ann Arbor City Code, Sign & Outdoor Advertising

Ann Arbor Historic District Design Guidelines for Signs

The following guidelines should be followed when replacing or installing new signage in historic commercial settings.

Appropriate

- Preserving historic painted signs where they exist.
- Installing signage that is subordinate to the overall building composition.
- Mounting signage to fit within existing architectural features using the shape of the sign to help reinforce the horizontal lines of moldings and transoms seen along the street.
- Installing signage in the historic sign band area of the building, typically the area above the transoms or just above the storefront.
- Attaching signage through masonry joints, not masonry units, or through material that can be easily repaired, such as wood, when the signage is removed.
- Painting signs on window glass, or using vinyl decal letters, that can be removed without damaging historic materials.
- Installing signage that is compatible in size, style, material, and appearance to the historic resource and district.
- Installing signage that is lit from external light fixtures above or below the sign.
- Placing signs to align with others along the commercial block face.
- Consolidating signage for multiple businesses at a single storefront to reduce the total number of signs on the building.

- Providing a consolidated directory listing sign for all offices in a building to reduce the total number of signs on the building.

Not appropriate

- Installing signs that are too large or that are made from a material that is incompatible with the historic building or district.
- Obstructing character-defining features of a historic building with signage.
- Installing signs through brick, stone, or other masonry units in a manner that damages historic materials.
- Installing signs that are made of unfinished, pressure treated wood, or that have a rough, unfinished surface.
- Installing signs that have interior illumination or are backlit.
- Installing signs that are overly complex, use more than three or four colors or use fluorescent colors.
- Installing signs that use highly reflective materials that are difficult to read.
- Installing permanent free-standing signs.
- Mounting signs to project off of an awning.
- Installing several signs to advertise a single business.

Ann Arbor Historic District Commission

Design Guidelines for Solar Panels and Related Appurtenances

Introduction

In 2007, Ann Arbor was designated by the United States Department of Energy as a Solar America City. This designation has increased awareness of individuals' energy consumption and has encouraged residents to investigate the use of alternative utilities that consume fewer natural resources, without reducing the conveniences of modern life. The Ann Arbor Historic District Commission offers the following material in anticipation of the demands of property owners, providing specific guidelines that consider the impact of solar panels on historic resources.

In addition to the inclusion of solar panels or solar shingles to the historic resource, the resource's owner must demonstrate that the addition of the solar panels is a part of a comprehensive energy-reducing plan that is compliant with the Secretary of the Interior's Standards for Rehabilitation and Guidelines for the overall benefit of the resource. This plan must be provided as part of the application.

How the Secretary of the Interior's Standards Apply

Standard 2. The historic character of a property will be retained and preserved. The removal of historic materials or alteration of features, spaces, and spatial relationships that characterize a property will be avoided.

The Standards refer to "character-defining features" of a property: examples include doors, windows, porches, transoms, and the like. Both the materials and the arrangement of these features define a property's historic character, which must not be obscured, radically changed, damaged, or destroyed in making a property more energy efficient.

Example: A business owner whose building faces south wants to install an array of solar panels. Because any significant alteration to the primary facade would obscure character-defining features, the HDC could not approve installation of the south-facing wall, and the owner would have to propose an alternative location for the solar array – e.g., on the roof. *Standard 5. Distinctive materials, features, finishes, and construction techniques or examples of craftsmanship that characterize a property will be preserved.*

Example: A homeowner proposes to install solar panels on a stucco wall. HDC would be required to review the effect of the installation on the stucco finish. If the likely consequence would be to cause the finish to deteriorate, the HDC would have to deny the application.

Standard 9. New additions, exterior alterations, or related new construction will not destroy historic materials, features, and spatial relationships that characterize the property. The new work will be differentiated from the old and will be compatible with the historic materials,

features, size, scale and proportion, and massing to protect the integrity of the property and its environment.

Alterations to the exterior must not be so intrusive that they destroy the integrity of the building's character by their very presence. Repairs or alterations must not damage or destroy historic materials directly or indirectly.

Example: A business owner proposes to install a solar array on the rear wall of a building. Although the proposed installation would not obscure or damage character-defining features, and no historic material would be destroyed, it is not clear what effect the weight of the new equipment would have on the structural integrity of the wall. The HDC might then require the owner to obtain a professional structural analysis of existing physical conditions to demonstrate that the installation will do no long-term damage to the building.

Example: A homeowner proposed to install a row of solar panels on the south-facing rear roof of her house. The panels would be fixed at a 69-degree angle from the horizontal, while the roof lies at a 45-degree angle. Because the HDC must consider the effect of the proposed work on the massing of the house – that is, the outline of the building – the Commission might require that the panels be fixed at the same angle as the surface on which they are installed, even if that is not the optimal angle for solar collection.

Standard 10. New additions and adjacent or related new construction will be undertaken in such a manner that, if removed in the future, the essential form and integrity of the historic property and its environment would be unimpaired.

The HDC must consider not only the details of installation of a system, but also how it will be uninstalled and what effect that would have on the physical integrity of the structure. The method of eventual removal and repair of any resulting damage to the structure shall be clearly identified in the HDC application and any work permit application.

Appropriate

- Placing freestanding or detached solar collectors in locations that are not visible from the public right-of-way.
- Mounting solar panels at grade or on ground pole mountings. In the absence of an appropriate ground-based mounting location, panels should be mounted on side or rear facing roof surfaces.
- Installing mechanical and service equipment on the roof related to the solar units and their related devices so that they are inconspicuous from the public right-of-way and do not damage or obscure character-defining features. Such equipment should be installed in such a manner that over time the equipment will not cause damage to the resource.

- For sloped roof installations, mounting solar panels parallel to and within 8” of roof surface.
- On flat roof structures, installing solar panels set back from the roof edge to minimize visibility. Pitch and elevation should be adjusted to reduce visibility from the public right-of-way.
- Installing solar panels to provide maximum coverage of the available roof surface. When such an application is not feasible, place the panels in the most unobtrusive configuration, noting that for the most efficient application, the highest installation is generally the most favorable.
- Positioning solar panels behind existing architectural features such as parapets, dormers, and chimneys to limit their visibility.
- Using solar panels and mounting systems that are compatible in color to established roof materials. All equipment, including the panels, frames and mounting hardware should be in a similar or compatible color to the surface on which it is mounted.
- Providing adequate structural support for all new mechanical equipment.
- Installing vertical runs of ducts, pipes, and cables in closets, service rooms, and wall cavities.
- Integrating solar panels into the design of new construction at the earliest point possible to assure cohesion of design within a historic context.
- Solar shingles and other types of solar collectors will be considered on a case-by-case basis by the Commission.

Not Appropriate

- Mounting solar panels and their related devices on primary elevations or roofs that face the primary elevation or in planes that are highly visible from the street view. This location has the highest impact on the historic character of the historic building and all other options should be thoroughly explored.
- Placing freestanding or detached solar collectors in locations that detract from and/or destroy historic landscape materials.
- Removing historic roofing materials during the installation of solar panels.
- Removing or altering the historic roof configuration – dormer, chimneys, or other character defining features – to add solar panels.

- Placing solar shingles on character defining elevations or visible from the street facing façade.
- Any other alteration or installation procedure that will cause irreversible changes to historic features or materials.

Application Materials

The following materials must be submitted with a completed HDC application. Additional information that may clarify the application is encouraged.

- Completed *Residential Solar Panel Worksheet* diagram (see attached)
- Photos of the roof where the panels are intended to be located
- Overall Energy Reduction plan for the historic resource
 - Include list of work previously performed and dates of work
 - Include list of work remaining to be performed and their estimated dates of work after the installation of the proposed solar panel system
 - Provide estimated energy savings or energy production caused by the installation of the proposed system
 - Provide written statement of energy savings due to work performed up to this point
- Manufacturer's product cut sheets, clearly denoting which system will be installed
- Manufacturer's photographs of the panels
- Manufacturer's installation methods, including type and location of mounting hardware and converter/wiring/metering details
- A section view showing the relationship of the panels to the roof slope, distance from roof surface to panels, and thickness of panels.

Administrative Approvals

City Staff may issue a certificate of appropriateness for solar panel installations that meet the following criteria. Other installations require review and issuance of a Certificate of Appropriateness by the Historic District Commission.

Installation of new **solar panels** on non-character defining roof surfaces not visible from the street or other character defining elevations, provided the solar panels are flat, do not extend more than 8" above the roof surface, are similar to the color of the roof material and cover not more than 10% of the roof surface on which they are located.

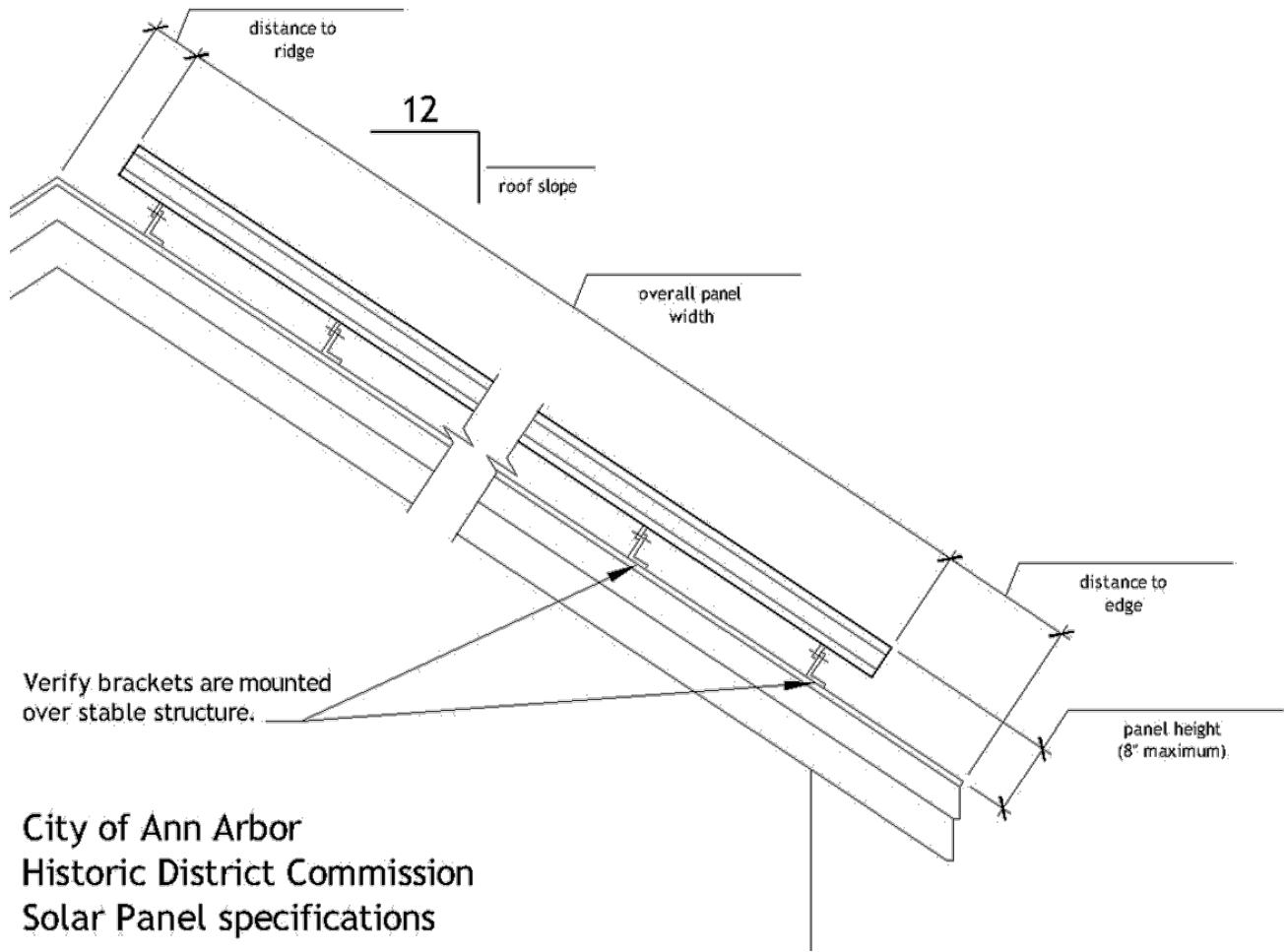

**Ann Arbor Historic District Commission
Residential Solar Panel Worksheet**

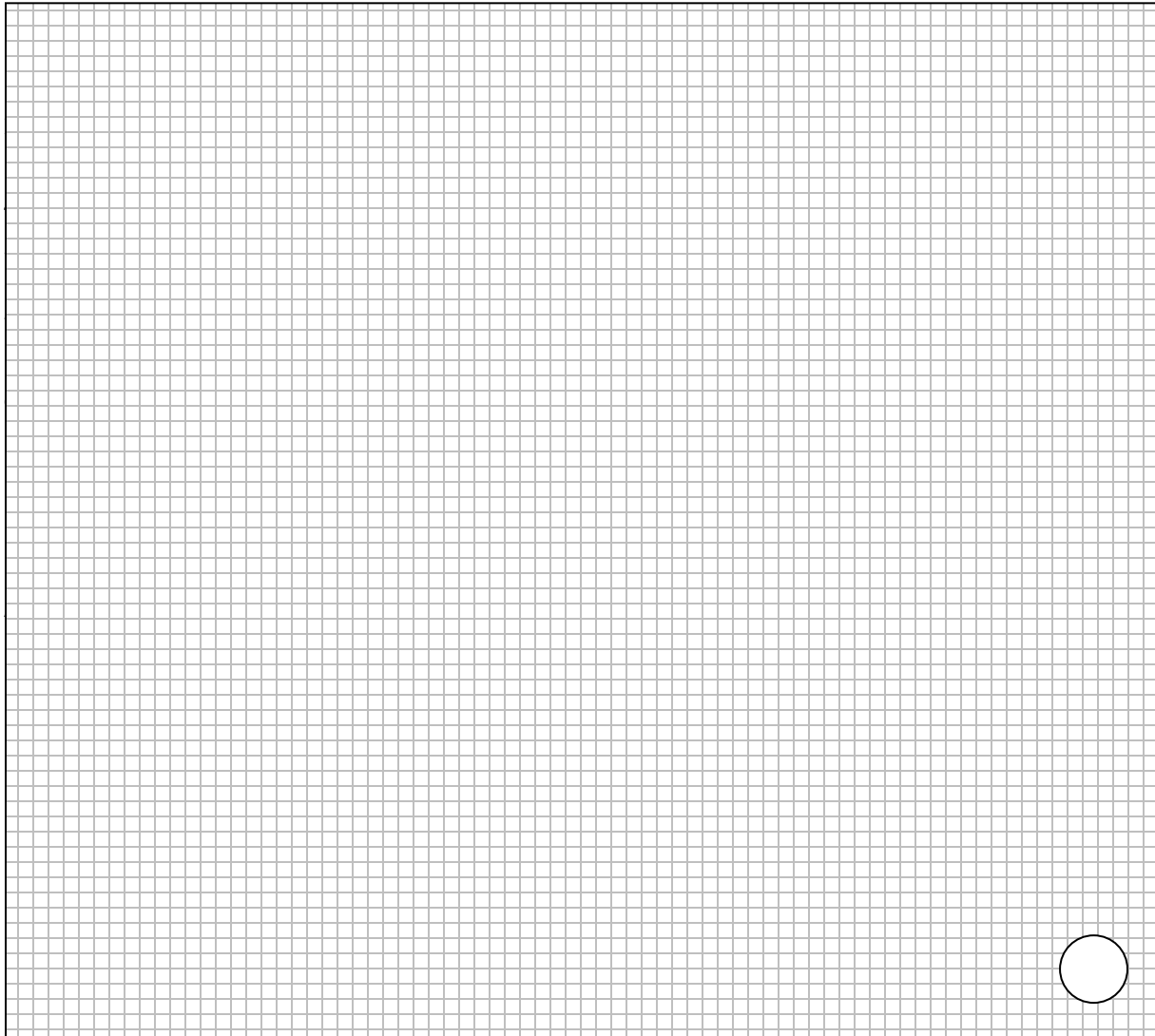

1. Drawing scale: 1 square = _____
2. Roof pitch(es) _____
3. Roof color and material _____
4. Solar panel color _____
5. Frame color _____
6. Size of individual panel(s) _____
7. Overall dimensions of installation _____
8. Sketch Lot plan and provide Lot dimensions
9. Show Building footprint and Roof ridge(s)
10. Label approximate distances to property lines
11. Identify north/south
12. Indicate location of adjacent street(s)
13. Show significant roof accessories (dormers, chimneys)

**Ann Arbor Historic District Commission
Residential Solar Panel Worksheet**

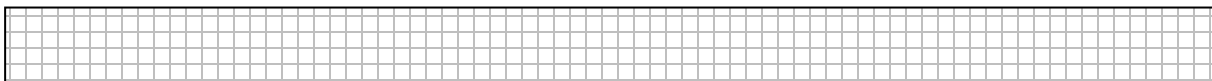

1. Drawing scale: 1 square = 2'-0"
2. Roof pitch(es) 8:12
3. Roof color and material charcoal asphalt
4. Solar panel color blue-black
5. Frame color matte grey
6. Size of individual panel(s) 36" x 60"
7. Overall dimensions of installation 108" x 120"
8. Sketch Lot plan and provide Lot dimensions
9. Show Building footprint and Roof ridge(s)
10. Label approximate distances to property lines
11. Identify north/south
12. Indicate location of adjacent street(s)
13. Show significant roof accessories (dormers, chimneys)

ANN ARBOR HISTORIC DISTRICT COMMISSION
GUIDELINES FOR WINDOW EVALUATION, REPAIR AND REPLACEMENT

The history of architecture might be summarized as a quest for light. Thus, windows are one of the most important architectural elements in the design of any building. We take them for granted, look out of them to view our world, open them to let in light and air, and close them to keep out the cold. They seem only utilitarian parts of our homes, but are much more. Windows strongly communicate the character and beauty of our homes, both interior and exterior. Their layout, materials, size, and even type of operation are critical elements of the character and style of our buildings. A Greek Revival style home is in part defined by the six-over-six muntin pattern of its windows, just as tall, narrow windows characterize a Gothic Revival home. In fact, windows are typically considered to be character-defining features of most buildings, from high-style monuments to vernacular homes. Even the details of windows generally resemble and reflect other design details found in the home. Those with old, wavy panes show the heritage of hand-made glass. Because windows are such critical features of buildings, the Historic District Commission generally requires repair and maintenance of windows in historic buildings.

Replacement guidelines

Windows in good condition will remain. Normal maintenance will include cleaning, sash cord replacement, limited paint removal, re-caulking where necessary, and new paint to make windows fully operable. Weather stripping and storm windows may be added.

Windows in somewhat good condition will receive repair, such as new wood or epoxy laid into sills, jamb, or sash. Deteriorated parts, such as sash locks and cords, will be replaced.

Seriously deteriorated components that cannot be repaired will be replaced with a sash of like material and identical layout (muntin size, glass area, rail size and stile size) to the original. Insulated glass is permitted in sash replacement. (Relevant criteria for window replacement apply.)

Windows and components deteriorated beyond repair (deep rot, missing parts, major perimeter gaps) are the only elements that the Historic District Commission will consider for replacement.

Window Replacement Application Procedure

1. Together with an Application for a Certificate of Appropriateness, the applicant will submit one set of Window Specifications outlined on the attached form for each window proposed for replacement. In completing the Specifications form, applicants are encouraged to retain a capable professional who is familiar with the window types and window components shown on the following pages. The Historic District Commission maintains a list of local firms and individuals competent in window repair and sash replacement that can assist with completing the Specifications.
2. The applicant or their consultant must also provide a detailed account of the condition of the windows' deteriorated components and describe how the proposed repairs or replacement windows compare to the existing components.
3. At the Review Committee site visit, the Historic District Commission's representatives will complete a Window Condition Survey for each window where significant repair or for replacement is being proposed. The findings of the Survey(s) will be compared to the detailed account provided by the applicant and will be delivered to the full Historic District Commission for consideration at their regular meeting.

Window Types



Double-Hung: A window with two sashes, each movable vertically by means a sash cord and weights, or some other mechanism. Double-hung windows are the most common.

Modern versions have a tilt sash for easy cleaning of the outside panes.



Casement: A single window sash that opens on hinges fixed to its vertical edge. The casement window's full-height opening provides excellent ventilation. Casements, especially wooden ones, can suffer damage if left open to the elements.

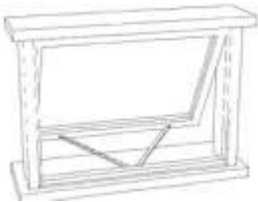

Awning: A window that is hinged at the top and swings outward. Awning windows are often used for ventilation under large, fixed-pane windows in contemporary homes. They keep out the elements when open, as long as the wind is not blowing hard.

Oriel window: Similar to a bay window, typically constructed of multiple windows projecting from the face of the building, but supported by brackets or corbels, rather than a foundation.

Jalousie: Window made up of horizontally mounted glass louvers or slats that abut each other tightly when closed and rotate outward when cranked open.



Fixed: A fixed frame window (or part thereof) that does not open. Fixed windows have sash that are permanently fixed to the frame. They are often flanked by double-hungs or casements, or set above or below an awning or hopper. They come in a variety of shapes, including round, half-round, diamond, and trapezoid (to echo gable-end rafter pitches).

Bay window: A composite of three windows, constructed on a foundation and usually made up of one large fixed, center window and two angled, flanking units.

Hopper: Similar to an awning window, but the hinges are located at the bottom of the window and the unit tilts inward.

Window Components

The graphic below highlights a window's numerous components, shown in a section through a 4/1 double hung window, viewed from the exterior.

- A. **Apron:** Non-moving, interior portion of the window below the sill.
- B. **Casing:** The finished, visible framework around a door or window.
- C. **Drip cap:** A usually small, horizontal molding strip located above a door or window casing; designed to shed water, causing it to drip beyond the outside of the frame.
- D. **Frame:** The fixed, outer portion of the window that holds the sash.
- E. **Jamb:** The vertical member at each side of the window frame.
- F. **Lights:** The glass within the window; can refer to the number of divided areas of glass.
Mullion (not pictured): A vertical member between window units set in a series.
- G. **Muntins:** Secondary framing members that hold the panes of glass within a window or window wall.
- H. **Pane:** A single piece of window glass.
- I. **Parting Bead:** The vertical strip on each jamb that separates the sashes of a double-hung window.
- J. **Rail:** Horizontal members of the sash.
- K. **Sash:** The framework into which panes are set.
Sash lock: (not pictured): mechanism that, in the locked position, pulls the upper and lower sash together. Also called a Cam lock
- L. **Sill:** The exterior horizontal portion at the bottom of a window. The sill keeps the jamb boards lined up properly and is angled to drain water off the surface. The sill should be watched for moisture damage and rot.
- M. **Stile:** Any vertical member of a sash.
- N. **Stool:** The interior casing or molded piece running along the base of a window and contacting the bottom rail on the inside of a building. Also known as the interior sill.
- O. **Stop:** The removable vertical strip against which a window sash rest
Brick mould (not pictured): external trim that frames windows and doors in masonry walls.

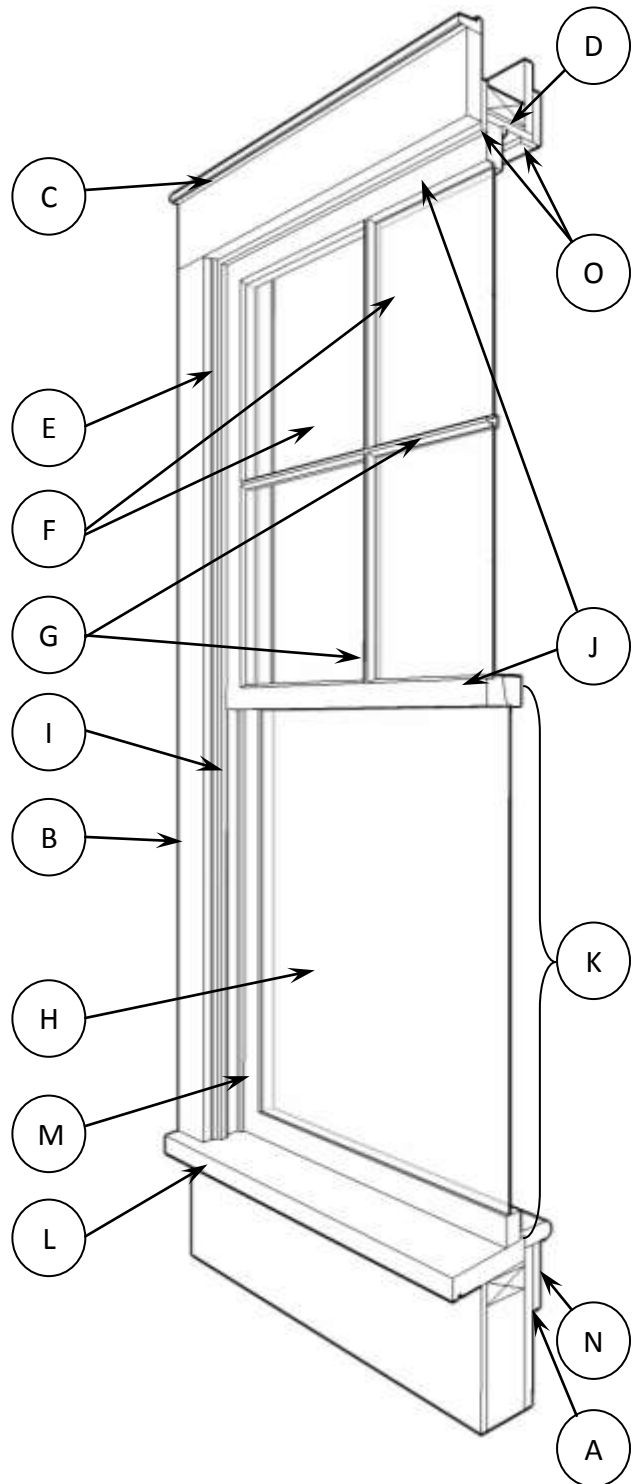

Window Specifications

Refer to the criteria below for proper measurements. For cases of necessary replacement, the Historic District Commission requires that a new window meet *all* of the following criteria:

The viewable profile dimensions of the exterior rails and stiles are within 1/4" of the original.

Sash Face	Existing	Proposed
Distance	_____	_____

Head Detail

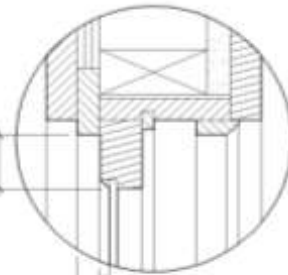

The window unit type matches the original (double-hung, casement, etc.)

Window Type
Do the proposed windows' types match the existing types?
Yes _____ No _____

The distance from sash face to back of casing is within 1/8" of the original dimensions, but not less than 3/8" total.

Profiles	Existing	Proposed
Distance	_____	_____

The number and location of muntins matches the original.

Muntins
Does the count and arrangement of muntins match the original?
Yes _____ No _____

The casing width and thickness (including drip cap, if applicable) are within 1/8" of the original.

Casing Thickness	Existing	Proposed
Distance	_____	_____

Jamb Detail

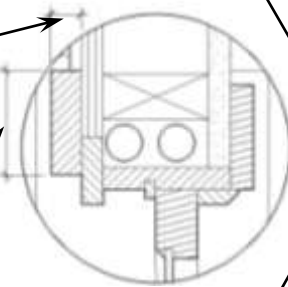

The distance from glass surface to exterior surface of muntin, rail and stile is at least 3/8"; AND the exterior surface of the unit's glass insets in the sash is within 1/8" of the original.

Glass Inset	Existing	Proposed
Distance	_____	_____

Casing Width	Existing	Proposed
Distance	_____	_____

The sill is similar in pitch to the original, extends to the outer edge of casing, and has a thickness within 1/8" of the original.

Sill Pitch	Existing	Proposed
Distance	_____	_____

The glass size remains within 90% of the original in both directions.

Glass Size	Existing	Proposed
Height	_____	_____
Width	_____	_____

Sill Thickness	Existing	Proposed
Distance	_____	_____

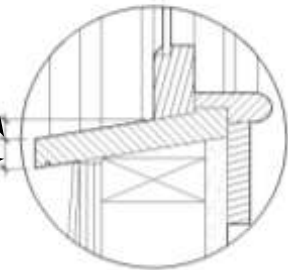

Sill Detail

Refer to Window Resource List for those individuals and companies who may be equipped to aid in the window evaluation/repair.

**BYLAWS OF THE
ANN ARBOR HISTORIC DISTRICT COMMISSION – CITY OF ANN ARBOR, MICHIGAN**

Article I. Name

The name of this commission is the Ann Arbor Historic District Commission.

Article II. Enabling Authority

The Ann Arbor Historic District Commission is established by Ann Arbor City Code, Chapter 8, section 1:191 and operates pursuant to Ann Arbor City Code, Chapter 103, Historic Preservation and the Michigan Local Historic Districts Act, Act 169 of 1970, MCL § 399.201 et seq.

Article III. Purpose, Objectives, and Duties

Section 1. The purpose of the Ann Arbor Historic District Commission ("the Commission") is to implement Chapter 103 of Ann Arbor City Code and the Michigan Local Historic Districts Act.

Section 2. The Commission shall submit an Annual Report to City Council in April of each year, detailing the activities of the Commission for the previous calendar year. Commission staff shall prepare a draft Annual Report in time for the Commission to review at the March regular meeting. The report shall contain, at a minimum, the total number of applications submitted, the number of applications handled by staff versus those considered by the Commission, the number of certificates of appropriateness and notices to proceed issued and denied, the names of award winners, and a description of the work of any active study committee.

Section 3. The Commission shall have all powers and duties of commissions authorized by Chapter 103 of Ann Arbor City Code and by Public Act 169 of 1970, as amended, MCL 399.201 et. seq., including but not limited to the following pursuant to Chapter 8, section 1:191 of Ann Arbor City Code:

(1) To hold public hearings and review applications for work in proposed and designated historic districts, and to issue certificates of appropriateness, notices to proceed, and denials of applications for work pursuant to Chapter 103 of Ann Arbor City Code;

(2) To conduct an ongoing survey to identify historically and architecturally significant properties, structures, and areas that exemplify the cultural, social, economic, political, or architectural history of the nation, state, or city;

- (3) To determine an appropriate system of markers and make recommendations for the design and implementation of specific markings of the streets and routes leading from one historic district to another;
- (4) To advise and assist owners of property or structures within historic districts on physical and financial aspects of preservation, renovation, rehabilitation, and reuse, and on procedures for inclusion on the state and national registers of historic places;
- (5) To review and comment on any national register nominations submitted to the Commission;
- (6) To inform and educate the citizens of Ann Arbor concerning the historic and architectural heritage of the city by publishing appropriate maps, newsletters, brochures, and pamphlets, and by holding programs and seminars;
- (7) To appoint such citizen advisory committees as may be required from time to time;
- (8) To testify before and provide comments to all boards and commissions, including but not limited to the planning commission and the zoning board of appeals, on any matter affecting historically and architecturally significant property, structures, and area, as requested by a board or commission;
- (9) To confer recognition upon the owners of property or structures by means of certificates, plaques, or markers;
- (10) To develop preservation components in planning efforts undertaken by the city and to recommend such components to the planning commission and to the city council;
- (11) To review the current zoning ordinance and recommend to the planning commission and the city council any amendments appropriate for the protection and continued use of historically and architecturally significant property, structures, and areas;
- (12) To work with other interested organizations to record and promote an appreciation of local history and to preserve and designate historic buildings, structures, sites, districts and objects;
- (13) To develop design guidelines for work within historic districts;
- (14) To adopt bylaws and rules of procedure subject to city council approval.
- (15) To hold its meetings in compliance with the Open Meetings Act and to provide public notice of its meetings in accordance with that act;

(16) To keep records of resolutions, proceedings and actions, and make records available to the public in compliance with the Michigan Freedom of Information Act; and

(17) To undertake any other action or activity necessary or appropriate to the implementation of its powers and duties or to the implementation of the purpose of Chapter 103 of Ann Arbor City Code.

Article IV Membership

Section 1. The Commission shall consist of seven (7) Commissioners appointed by the Mayor and approved by City Council. The majority of the Commissioners shall have a clearly demonstrated interest in or knowledge of historic preservation. At least two (2) Commissioners shall be appointed from a list submitted by one (1) or more local historic preservation organizations. If such a person is available for appointment, one (1) Commissioner shall be a graduate of an accredited school of architecture who has two (2) years of architectural experience or who is an architect registered in the State of Michigan. If possible, one (1) Commissioner shall meet the professional qualifications for history as defined by the Secretary of the Interior's Historic Preservation Professional Qualifications Standards.

Section 2. All Commissioners shall serve without compensation. On a case by case basis, Commissioners may receive reimbursement for expenses incurred in the exercise of their duties or in continuing education in historic preservation, subject to the prior approval of the Community Services Area Administrator.

Section 3. All Commissioners shall be appointed for a three-year term. In order to insure that approximately one-third of the voting members' appointments expire each year, initial appointments shall be two (2) Commissioners for a one-year term, two (2) Commissioners for a two-year term, and two (2) Commissioners for a three-year term. Consistent with MCL § 399.204, Commissioners shall be eligible for reappointment.

Section 4. Consistent with City Charter § 12.2, all Commissioners shall have been registered electors in the City of Ann Arbor for at least one (1) year immediately preceding the time of appointment, unless an exception is granted by a resolution concurred in by at least seven (7) members of City Council. Consistent with City Code § 1:191 and MCL § 399.204, each Commissioner shall reside in the City of Ann Arbor.

Section 5. A Commissioner whose term has expired shall hold over and continue to serve until a successor has been appointed. Consistent with City Code §§ 1:171, 1:191 and MCL § 399.204, no Commissioner shall be allowed to hold over for more than 60 days beyond the appointed term whether or not a successor has been appointed.

Section 6. Consistent with City Code § 1:171, the Mayor shall notify City Council of the expiration of a Commissioner's term at least 30 days prior and shall present to City Council all proposed reappointments no later than 60 days after the expiration of the term.

Section 7. Consistent with City Code § 1:171, any vacancy on the Commission occurring in the middle of a term shall be filled for the remainder of the term in the same manner as

for full-term appointments. Consistent with City Code § 1:191 and MCL § 399.204, any vacancy shall be filled within 60 days,

Section 8. Commissioners are expected to attend regularly scheduled meetings and to notify the Chair and the primary staff liaison in advance if they expect to be tardy or absent. If a Commissioner misses more than three (3) regularly scheduled meetings in a twelve (12) month period, the Chair shall notify the Mayor and may recommend removal of the Commissioner.

Section 9. A Commissioner may be removed by the Mayor with the approval of Council for cause following notice and a hearing.

Section 10. Each retiring Commissioner who has not been removed for cause shall receive appropriate recognition and a certificate of commendation from the Commission that shall be prepared by the Chair or their designee.

Section 11. Commission staff shall conduct an orientation session for new Commissioners within two (2) months of appointment, which staff, the Chair or the Chair's designee shall attend. All Commissioners shall be notified of the time and place of the orientation and may attend. For the benefit of the new Commissioner(s), the Chair or designee shall review operational matters, including bylaws, procedures, and committees, and staff shall review Chapter 103, including the background of all current and proposed districts in the City. The following shall be provided to new Commissioners:

- (1) Chapter 103
- (2) Bylaws
- (3) Information about current Commissioners
- (4) Chronology of districts
- (5) Map of districts
- (6) Study Committee Reports for all current districts
- (7) The Secretary of the Interior's Standards for Rehabilitation and Guidelines for Rehabilitating Historic Buildings
- (8) Design Guidelines
- (9) Application and application guidelines

Article V Ethics and Conflicts of Interest

Section 1. A Commissioner shall abstain from discussion or voting on any matter where that Commissioner is involved in a real or apparent conflict of interest. Decisions regarding conflicts of interest shall be evaluated on a case-by-case basis with reasonable application of the principles provided in this Article. A conflict of interest shall at a minimum include, but is not necessarily limited to:

- a. A matter involving property in which that Commissioner, any member of his/her immediate family, his/her partner, or an entity with whom the Commissioner has family or business ties has an ownership or other direct interest.
- b. A matter where the Commissioner's employee or employer is an applicant or agent

for an applicant, or has a direct interest in the outcome.

- c. A matter which may result in a financial or other benefit to that Commissioner, any member of his/her immediate family, his/her partner, or an entity with whom the Commissioner has family or business ties.

Section 2. Each Commissioner shall complete an annual disclosure of employer and any other organization affiliations that reasonably could lead to a conflict of interest and shall update this disclosure in writing at any time during the year when such affiliations change.

Section 3. A Commissioner shall neither solicit nor accept gratuities, favors, or anything of monetary value from entities in a position to benefit from a decision of the Commission.

Section 4. Except where it violates a confidence, a Commissioner shall disclose all pertinent facts regarding any possible conflict of interest, real or apparent, and those facts shall be recorded in the minutes of the proceedings. The Commissioner may then abstain from discussion and voting on the matter.

Section 5. Where a question has arisen as to whether a Commissioner is ineligible to participate in discussion or vote on a matter because of a conflict of interest, the Commission may determine that the Commissioner is ineligible due to a conflict of interest by a vote of a majority of the other Commissioners present. Upon such a determination, the ineligible Commissioner shall not participate in discussion or vote on the matter.

Section 6. A Commissioner who cannot vote due to a conflict of interest shall, during deliberation of the matter before the Commission, leave the meeting or the area where the Commissioners sit until action on the matter is concluded.

Section 7. Commissioners shall not act, hold themselves out, or permit themselves to be perceived as official representatives or spokespersons for the Commission without authorization from the Chair. When communicating for personal purposes on matters that may relate to the Commission's business, Commissioners shall clearly indicate that their statements are made in a personal capacity and do not necessarily reflect the views of the Commission. Whenever a Commissioner is asked to speak on behalf of the Commission, he/she shall seek permission of the Chair in advance.

Section 8. A Commissioner shall not be heard before the Commission as an applicant, representative of an applicant, or as a party interested in an application during the Commissioner's term of office.

Section 9. Members of the City Council are discouraged from appearing before the Commission as a petitioner, representative of a petitioner or as a party interested in a petition during the Councilmember's term of office.

Section 10. The Commission or individual Commissioners shall not intrude into the management of the City Planning and Development Services Unit or into those matters which are handled administratively within the service unit.

Section 11. Commissioners may, but are not obligated to, provide professional services to

the Commission free of charge.

Section 12. Commissioners shall conduct themselves in a fair, courteous, and understanding manner at all times in the discharge of their duties, and shall avoid exchanges or actions based upon personal differences.

Article VI Officers

Section 1. The officers of the Commission shall be a Chair, Vice-Chair, and Secretary. The officers shall be elected from among the Commissioners by secret ballot each year at a regular meeting in October. Nominations may be made from the floor in addition to those in the report of the Nominating Committee. The officers shall be elected for a one-year term by a majority of the Commissioners currently serving on the Commission. No Commissioner shall serve more than two (2) consecutive full terms in the same office. The term of each officer shall run from November 1 to October 31 of the following year.

Section 2. The Chair shall preside at all meetings and shall decide points of order and procedure subject to the provisions of these bylaws and with the guidance of Robert's Rules of Order, as revised. The Chair shall have the privilege of discussing and voting on all matters before the Commission. The Vice-Chair shall assume the duties of the Chair in the Chair's absence. The Secretary shall assume the duties of the Chair if both the Chair and Vice-Chair are absent.

Section 3. When an office becomes vacant before the expiration of the current term (whether by resignation, removal, incapacity, or other circumstance), the vacancy shall be filled by election in the same manner as for full-term officers and the new officer shall serve the remainder of the term. The replacement officer shall be elected at the next regularly scheduled meeting or as soon as practicable. If a Commissioner serving in another office is elected to the vacant office, then that Commissioner's former office shall be filled by election in the same manner.

Section 4. No individual may hold more than one (1) office at a time.

Article VII Meetings

Section 1. The Commission shall conduct regularly scheduled meetings at least monthly. Regular meetings shall be held on the second Thursday of each month unless the Commission sets alternate dates by resolution. The schedule of regular meetings for the following fiscal year shall be determined by the Commission before the end of the current year. Notice of the year's schedule of regular meetings shall be posted at least forty-eight (48) hours prior to the first meeting of the year.

Section 2. Special meetings may be called by the Chair in his/her discretion and shall be called by the Chair upon the written request of two (2) Commissioners. The purpose of the special meeting shall be stated in the public notice for that meeting. At the special meeting, the Commission may not conduct any business beyond the specific purpose stated in the public notice, except by unanimous consent of the voting members present. Public notice of the special meeting shall be posted at least eighteen (18) hours prior to the scheduled starting time.

Section 3. The Commission may hold non-voting working meetings to carry on the work of the Commission. Public notice of the working meeting shall be posted at least eighteen (18) hours prior to the scheduled starting time.

Section 4. Public notice of committee meetings shall be posted at least eighteen (18) hours prior to the scheduled starting time.

Section 5. Public notice of all meetings shall be posted at City Hall.

Section 6. Notice of each meeting shall be provided to all Commissioners at least forty-eight (48) hours prior to the scheduled starting time for all regular and special meetings and at least eighteen (18) hours prior for all rescheduled and committee meetings.

Section 7. The Chair may cancel a meeting due to weather, emergency, or other circumstances that may substantially limit the ability Commissioners or the public to attend. The Chair shall give notice of cancellation to Commissioners and Commission staff at least two (2) hours prior to the scheduled meeting time, where practicable. The Chair shall post public notice of the cancellation as soon as practicable. The Chair may reschedule cancelled meetings after consulting with staff. Public notice for rescheduled regular or special meetings shall be posted at least eighteen (18) hours prior to the scheduled starting time.

Section 8. A majority of all voting members currently serving on the Commission shall constitute a quorum. A concurring vote of the majority of all Commissioners present is required for the Commission to pass any motion. The right to vote is limited to Commissioners actually present at the time the vote is taken at a lawfully called meeting. A Commissioner who is not eligible to vote on a matter because of a conflict of interest shall not be counted in establishing a quorum for that matter.

Section 9. Except for the election of officers, voting shall be by voice and a show of hands. If the vote is not unanimous, a roll call vote shall be taken and recorded in the minutes.

Section 10. The Commission shall arrange to keep minutes of all meetings, which shall be a record of the Commission's consideration and actions, and which shall include at a minimum a list of those Commissioners present and not present at each meeting; identifying information, where given, of all persons appearing before the Commission; a copy of each resolution or other matter acted upon by the Commission and a description of the outcome of each action. All shall be filed in the City Clerk's Office and shall be a public record.

Section 11. All meetings of the Commission and its committees shall be open to the public and conducted in accordance with the Michigan Open Meetings Act (PA 267 of 1976), as amended. Closed sessions may be called for purposes listed in the Open Meetings Act.

Section 12. Public comment shall be allowed at all meetings. Applicants shall be given sufficient time to present their application, subject to reasonable limits set in the Chair's

discretion. Other speakers may speak for up to three (3) minutes on any item open for public comment. The Chair may extend an individual's speaking time in his/her discretion. Public comment on non-agenda items may be limited in the Chair's discretion. Speakers shall be requested to provide their name and address for the record.

Section 13. Applicants must submit all materials pertinent to their application to Commission staff no later than ten (10) business days prior to the meeting at which the application is to be considered.

Section 14. Applicants shall specify whether they are requesting a certificate of appropriateness or a notice to proceed, and may not request consideration of both in the same application. An applicant may not file more than one (1) application for substantially similar work until any previously filed applications for such work have been acted upon by the Commission or withdrawn. A subsequent application for work that is substantially similar to work already considered by the Commission will not be accepted unless the applicant presents evidence showing a substantial change in facts, circumstances, or the nature of the work, or the applicant is requesting a different approval from the Commission, e.g. a notice to proceed instead of a certificate of appropriateness. The Commission may require additional information or evidence in order to consider a notice to proceed.

Section 15. Commissioners who attend non-Commission meetings as a representative of the Commission shall prepare a brief written or oral report, including at a minimum the date, time, place, sponsoring organization, and topics discussed, unless Commission staff is present at the meeting to prepare such a report. When practicable, the report shall be submitted to Commission staff in time to be included in the packet for the following regular meeting.

Section 16. The Chair shall approve any report that a Commissioner proposes to submit to a non-Commission committee, board, task force, or other body on which a Commissioner serves as official representative of the Commission. A copy of the report shall be included in the packet for the next regular meeting after approval.

Article VIII Agenda and Order of Business

Section 1. The agenda for each meeting of the Commission shall be developed by the Chair and the Historic Preservation Coordinator or other delegated staff member. Agendas for all regular meetings shall be made available to the public and Commissioners at least forty-eight (48) hours before the meeting's scheduled starting time.

Section 2. The suggested order of business at regular meetings shall be as follows. Once the agenda is approved, the order of business may be suspended or modified by a majority of those Commissioners present.

- a) Call to Order
- b) Roll Call
- c) Approval of Agenda
- d) Regular Business

- e) Public Comment on Non-Agenda Items
- f) Approval of Minutes
- g) Reports from Commissioners
- h) Assignments
- i) Reports from Staff
- j) Concerns of Commissioners
- k) Communications
- l) Adjournment

Section 3. The order of business for considering applications for certificates of appropriateness or notices to proceed shall be as follows. The order of business may be suspended or modified in the Chair's discretion, with the consent of the Commission.

- a) Chair calls the case
- b) Staff presentation, including a brief description of the property's location, historic district, and history including any significant changes to the original configuration, a summary of the application, and any staff findings or recommendations
- c) Review Committee's reports and recommendations
- d) Public hearing
 - 1. Applicant's presentation. Applicants are encouraged to address the Commission on their own behalf and may bring such other persons as may be necessary to support their application.
 - 2. Questions by the Commission of the applicant
 - 3. Public comment on the current application
 - 4. Applicant response, if requested
- e) Closing of public hearing, followed by Commission discussion and action. Further comment from the applicant or other members of the public shall not be allowed during this time unless authorized by the Chair with the consent of the Commission.

Article IX Committees

Section 1. The Commission may create standing or special committees to carry on the work of the Commission. Standing committees may, but need not be, described in the bylaws. Committees shall be limited to performing the tasks delegated to them by the Commission. Each committee shall include at least one (1) Commissioner and may contain other community members, in the Commission's discretion.

Section 2. Members of committees shall be appointed by the Chair and approved by the Commission.

Section 3. Nominating Committee. The Commission shall appoint a Nominating Committee at the first regular meeting in September whose duty shall be to present nominations for officers at the October meeting.

Section 4. Review Committee. A Review Committee shall be established for each regular meeting or as otherwise necessary to carry out the Commission's business. Each Review Committee shall consist of Commission staff, any consultants deemed necessary, and at least two (2) Commissioners. Each Commissioner is expected to serve on a Review Committee at least three (3) times annually. Commission staff shall have discretion to select the members of each Review Committee in consultation with the Chair.

(1) All members of the Review Committee shall endeavor to visit each site that is the subject of an application on the Monday prior to the meeting at which the application will be considered, or at another convenient time. If an application is being reconsidered or consideration is being continued from a previous meeting, Commission staff, in consultation with the Chair, may determine that a Review Committee visit is not necessary.

(2) The names of those persons who visited each site as part of the Review Committee shall be listed in the minutes for each meeting.

(3) When the Review Committee is scheduled to visit a structure that is proposed for demolition, all Commissioners shall be notified of the Review Committee meeting time and place.

(4) Subject to the approval of the property owner, a representative of a neighborhood association or member of the public may attend the Review Committee's site visits. Each neighborhood association must submit the name of the attending representative prior to the visit.

Article X Parliamentary Authority

Section 1. The rules contained in the current edition of Robert's Rules of Order Newly Revised shall guide the Commission; however parliamentary procedure shall be flexible and may be adjusted in the Chair's discretion to best serve the needs of the Commission. Nevertheless, no procedure shall be adopted that is inconsistent with these bylaws.

Section 2. The Commission shall not adopt or follow any operating rules, regulations, or guidelines not expressly prescribed by these bylaws.

Article XI Amendment of Bylaws

Section 1. Amendments to these bylaws may be approved at any regular meeting by a two-thirds vote of those Commissioners who are present, but in no case by fewer than four (4) votes, provided that notice of the substance of any proposed amendments was provided to the Commission at the previous regular meeting and specific proposed wording was included in the Commission's packet for the meeting at which the proposed amendment will be considered. Proposed amendments must be submitted to the Office of the City Attorney for review and amendments approved by the Commission shall not be effective until approved by City Council, which shall have final discretion to modify

these bylaws. Amended bylaws shall be transmitted to the State Historic Preservation Office within 30 days of approval by City Council.

Section 2. These bylaws shall be reviewed by the Commission annually for possible amendment. The review shall be at the Commission's annual retreat unless another time is set by the Chair.

Article XII Miscellaneous

Section 1. At the discretion of the City Administrator, or as otherwise mandated by City Council, the staff of Planning and Development Services shall be the primary provider of administrative support and professional advice to the Commission and the Planning and Development Services Manager or their designee shall be the primary liaison between the Commission and Planning and Development Services staff.

Section 2. The Commission shall not review any plans for Cobblestone Farm until after the Cobblestone Farm Association Board of Directors has reviewed the same plans and taken action upon them.

Section 3. Design guidelines shall be approved by the Commission and the State Historic Preservation Office consistent with MCL 399.205(3).

Section 4. Categories of work that are delegated to staff for administrative approval under Ann Arbor City Code, Chapter 103, § 8:414 and MCL 399.205(10) shall be approved by the Commission and recorded on a "Staff Approvals List."

Section 5. The Ann Arbor City Attorney's Office shall be the legal consultant to the Commission.

Section 6. Planning and Development Services staff may consult with the officers of the Commission to: determine whether an application for work meets the criteria for staff approval on behalf of the Commission, or; to assist with questions pertaining to clarification of an application or potential application for a certificate of appropriateness.

Adopted by the Commission on May 9, 2013

CHAPTER 8
(ORGANIZATION OF BOARDS AND COMMISSIONS)

AN ORDINANCE TO AMEND SECTION 191 OF CHAPTER 8 (ORGANIZATION OF BOARDS AND COMMISSIONS) OF TITLE I OF THE CODE OF THE CITY OF ANN ARBOR, TO REPEAL CHAPTER 103 (HISTORICAL PRESERVATION) OF TITLE VIII OF THE CODE OF THE CITY OF ANN ARBOR, AND TO AMEND THE CODE OF THE CITY OF ANN ARBOR BY ADDING A NEW CHAPTER WHICH NEW CHAPTER SHALL BE DESIGNATED AS CHAPTER 103 (HISTORIC PRESERVATION) OF TITLE VIII OF SAID CODE.

The City of Ann Arbor ordains:

Section 1. That Section 1:191 of Chapter 8 of Title I of the Code of the City of Ann Arbor be amended to read as follows:

1:191. Historic district commission.

The historic district commission shall consist of 7 members who shall be appointed by the mayor with the approval of city council for 3-year terms. Each member shall reside in the city. The majority of the members shall have a clearly demonstrated interest in or knowledge of historic preservation. At least 2 members shall be appointed from a list submitted by 1 or more local historic preservation organizations. If such a person is available for appointment, 1 member shall be a graduate of an accredited school of architecture who has two years of architectural experience or who is registered in the State of Michigan.. A vacancy on the commission shall be filled within 60 calendar days. If possible, 1 member of the commission shall meet the professional qualifications for history as defined by the Secretary of the Interior's Historic Preservation Professional Qualifications Standards. The historic district commission shall have all powers and duties of commissions authorized by Chapter 103 of this Code and by Public Act 169 of 1970, as amended, MCL 399.201 et. seq., including but not limited to the following:

- 1 To hold public hearings and review applications for work in proposed and designated historic districts, and to issue certificates of appropriateness, notices to proceed, and denials of applications for work pursuant to Chapter 103 of this Code.
- (2) To conduct an ongoing survey to identify historically and architecturally significant properties, structures, and areas that exemplify the cultural, social, economic, political, or architectural history of the nation, state, or city;
- (3) To determine an appropriate system of markers and make recommendations for the design and implementation of specific markings of the streets and routes leading from one historic district to another;

CHAPTER 103
(HISTORIC PRESERVATION)

8:405. Title.

This Chapter shall be known as the “Historic Preservation Ordinance” of the City of Ann Arbor.

8:406. Purpose.

Historic preservation is hereby declared to be a public purpose and the city may hereby regulate the construction, addition, alteration, repair, moving, excavation, and demolition of resources in historic districts within the city as provided in this chapter. The purpose of this chapter is to:

- (1) Safeguard the heritage of the city by preserving historic districts which reflect elements of the city’s history, architecture, archaeology, engineering, or culture;
- (2) Stabilize and improve property values in the districts and the surrounding areas;
- (3) Foster civic beauty;
- (4) Strengthen the local economy; and
- (5) Promote the use of historic districts for the education, pleasure and welfare of the citizens of the city and of the State of Michigan.

8:407. Definitions.

For the purposes of this chapter, the following words and phrases shall have the meanings described in this section:

- (1) *Alteration* means work that changes the detail of a resource but does not change its basic size or shape.
- (2) *Certificate of appropriateness* means the written approval of a permit application for work that is appropriate and that does not adversely affect a resource.
- (3) *Commission* means the historic district commission appointed by city council under Chapter 8 of this Code.
- (4) *Demolition* means the razing or destruction, whether entirely or in part, of a resource and includes, but is not limited to, demolition by neglect.
- (5) *Demolition by neglect* means neglect in maintaining, repairing, or securing a resource that results in deterioration of an exterior feature of the resource or the loss of structural integrity of the resource.

- (6) *Denial* means the written rejection of a permit application for work that is inappropriate and that adversely affects a resource.
- (7) *Design guideline* means a standard of appropriate activity that will preserve the historic and architectural character of a property, structure or area.
- (8) *Fire alarm system* means a system designed to detect and annunciate the presence of fire or by-products of fire. Fire alarm system includes smoke alarms.
- (9) *Historic district* means an area, or group of areas not necessarily having contiguous boundaries, that contains 1 resource or a group of resources that are related by history, architecture, archaeology, engineering, or culture.
- (10) *Historic preservation* means the identification, evaluation, establishment, and protection of resources significant in history, architecture, archaeology, engineering, or culture.
- (11) *Historic resource* means a publicly or privately owned building, structure, site, object, feature, or open space that is significant in the history, architecture, archaeology, engineering, or culture of the city, the State of Michigan, or of the United States.
- (12) *Local Historic Preservation Organization* means a duly organized local historic preservation organization, or neighborhood association representing a historic district, registered with the planning and development services unit.
- (13) *Notice to Proceed* means the written permission to issue a permit for work that is inappropriate and that adversely affects a resource pursuant to a finding under section 8:416.
- (14) *Open space* means undeveloped land, a naturally landscaped area, or a formal or man-made landscaped area that provides a connective link or a buffer between other resources.
- (15) *Ordinary maintenance* means keeping a resource unimpaired and in good condition through ongoing minor intervention, undertaken from time to time, in its exterior condition.

Ordinary maintenance does not change the external appearance of the resource except through the elimination of the usual and expected effects of weathering. Ordinary maintenance does not constitute work for purposes of this chapter.

- (16) *Proposed historic district* means an area, or group of areas not necessarily having contiguous boundaries, that has delineated boundaries and that is under review by a study committee for the purpose of making a recommendation as to whether it should be established as a historic district or added to an established historic district.
- (17) *Repair* means to restore a decayed or damaged resource to a good or sound condition by any process. A repair that changes the external appearance of a resource constitutes work for purposes of this chapter.
- (18) *Resource* means 1 or more publicly or privately owned historic or non-historic buildings, structures, sites, objects, features, or open spaces located within a historic district.
- (19) *SHPO* means the State Historic Preservation Office of the Department of History, Arts, and Libraries of the State of Michigan, or its successor.
- (20) *Smoke alarm* means a single-station or multiple-station alarm responsive to smoke and not connected to a system. A single-station alarm is an assembly incorporating a *detector*, the control equipment, and the alarm sounding device into a single unit, operated from a power supply either in the unit or obtained at the point of installation. A multiple-station alarm is 2 or more single-station alarms that are capable of interconnection such that actuation of 1 alarm causes all integrated separate audible alarms to operate.
- (21) *Standing committee* means a permanent body established by city council to conduct the activities of a historic district study committee on a continuing basis.
- (22) *Study Committee* means a historic district study committee appointed by City Council under section 8:408.
- (23) *Work* means construction, addition, alteration, repair, moving, excavation, or demolition.

8:408. Historic District Study Committee.

- (1) Before establishing a historic district, city council shall by resolution appoint a study committee.
- (2) The study committee shall contain a majority of persons who have a clearly demonstrated interest in or knowledge of historic preservation, and shall contain representation from 1 or more local historic preservation organizations. At least one member shall reside or work in the affected area, and additional members may include representation from registered neighborhood associations and merchants' groups in the affected area. The term of office for study committee members shall end when city council takes final action on the committee's recommendations or at such earlier date as the city council by resolution directs.

- (3) The study committee shall do all of the following:
 - (a) Conduct a photographic inventory of resources within any proposed historic district following procedures established or approved by the SHPO.
 - (b) Conduct basic research of each proposed historic district and the historic resources located within that district.
 - (c) Determine the total number of historic and non-historic resources within a proposed historic district and the percentage of historic resources of that total. In evaluating the significance of historic resources, the study committee shall be guided by the selection criteria for evaluation issued by the United States secretary of the interior for inclusion of resources in the national register of historic places, as set forth in 36 CFR part 60, as amended, and criteria established or approved by the SHPO, if any.
 - (d) Prepare a preliminary historic district study committee report that addresses at a minimum all of the following:
 - (i) The charge of the study committee.
 - (ii) The composition of the study committee membership.
 - (iii) The historic district or districts studied.
 - (iv) The boundaries for each proposed historic district in writing and on maps.
 - (v) The history of each proposed historic district.
 - (vi) The significance of each district as a whole, as well as a sufficient number of its individual resources to fully represent the variety of resources found within the district, relative to the evaluation criteria.
 - (e) Transmit copies of the preliminary report for review and recommendations to the historic district commission, the planning commission, the SHPO, the Michigan Historical Commission, and the State Historic Preservation Review Board.
 - (f) Make copies of the preliminary report available to the public as required by section 8:408(7).
- (4) Not less than 60 calendar days after the transmittal of the preliminary report under subsection 3(e), the study committee shall hold a public hearing in compliance with the Open Meetings Act. Public notice of the time, date, and place of the hearing shall be given in the manner required by the Open Meetings Act. Written notice shall be mailed by first-class mail not less than 14 calendar days before the hearing to the owners of properties within the proposed historic district, as listed on the tax rolls of the city.

- (5) After the date of the public hearing, the study committee and city council shall have not more than 1 year, unless otherwise authorized or extended by city council, to take the following actions:
 - (a) The study committee shall prepare and submit a final report with its recommendations and the recommendations, if any, of the historic district commission and the planning commission to the city council. If the recommendation is to establish a historic district or districts, the final report shall include a draft of a proposed ordinance or ordinances.
 - (b) After receiving a final report that recommends the establishment of a historic district or districts, city council, at its discretion, may introduce and pass or reject an ordinance or ordinances. If city council passes an ordinance or ordinances establishing 1 or more historic districts, the city clerk shall file a copy of that ordinance or ordinances, including a legal description of the property or properties located within the historic district or districts, with the Washtenaw County Register of Deeds.
- (6) If a majority of the property owners within a proposed contiguous historic district, as listed on the tax rolls of the city, submit a petition to city council requesting the establishment of a contiguous historic district, then city council shall not pass an ordinance establishing a historic district without waiting at least 60 days from the date of filing of the petition.
- (7) A writing prepared, owned, used, in the possession of, or retained by a study committee in the performance of an official function shall be made available to the public in compliance with the Michigan Freedom of Information Act.

8:409 Standing Committee

- (1) City Council may establish a standing committee to conduct the activities of a study committee on a continuing basis.
- (2) The standing committee shall contain not less than 7 members. The majority of persons shall have a clearly demonstrated interest in or knowledge of historic preservation, and shall contain representation from 1 or more local historic preservation organizations. If possible, one member shall meet the qualifications for history and one member shall meet the qualifications for architectural history of the Secretary of the Interior's Historic Preservation Qualifications Standards. All members shall be residents of the City.
- (3) Standing committee members shall be appointed for 3-year terms, except the initial appointments of some members shall be for less than three years so that the initial appointments are staggered and subsequent appointments do not recur at the same time.

- (4) At its discretion, City Council may from time to time appoint additional members to the standing committee to consider only specific proposed districts. Additional members shall only vote on matters concerning the specific proposed districts they were appointed to consider.

The term of an additional member shall automatically end upon the final consideration of the specific proposed district by City Council.

8:410 Establishing, modifying, or eliminating historic districts.

- (1) The city may at any time establish by ordinance additional historic districts, including proposed districts previously considered and rejected, may modify boundaries of an existing historic district, or may eliminate an existing historic district. Before establishing, modifying, or eliminating a historic district a study committee appointed by city council shall, except as provided for in subsection (2), comply with the procedures set forth in section 8:408 and shall consider any previously written study committee reports pertinent to the proposed action.
- (2) If considering elimination of a historic district, a study committee shall follow the procedures set forth in section 8:408 for issuing a preliminary report, holding a public hearing, and issuing a final report but with the intent of showing 1 or more of the following:
 - (a) The historic district has lost those physical characteristics that enabled establishment of the district.
 - (b) The historic district was not significant in the way previously defined.
 - (c) The historic district was established pursuant to defective procedures.
- (3) Upon receipt of substantial evidence showing the presence of historic, architectural, archaeological, engineering, or cultural significance of a proposed historic district, city council may, at its discretion, adopt a resolution requiring that all applications for permits within the proposed historic district be referred to the commission. The commission shall review permit applications with the same powers that would apply if the proposed historic district was an established historic district. The review may continue in the proposed historic district for not more than 1 year, or until such time as city council approves or rejects the establishment of the historic district by ordinance, whichever occurs first.

8:411. Emergency moratorium.

If city council determines that pending work will cause irreparable harm to resources located within an established historic district or a proposed historic district, city council may by resolution declare an emergency moratorium of all such work for a period not to exceed 6 months.

City council may extend the emergency moratorium for an additional period not to exceed 6 months upon finding that the threat of irreparable harm to resources is still present. Any pending permit application concerning a resource subject to an emergency moratorium may be summarily denied by the building official.

8:412. Permit applications.

- (1) A permit shall be obtained before any work affecting the exterior appearance of a resource is performed within a historic district or, if required under section 8:415(2), work affecting the interior arrangements of a resource is performed within a historic district.
- (2) The person, individual, partnership, firm, corporation, organization, institution, or agency of government proposing to do that work shall file an application for a permit with the planning and development services manager or designee. The application shall be referred together with all required supporting materials that make the application complete to the commission. The applicant shall pay the application fee established by resolution of city council before the city will process a permit application. Supporting materials may include plans, drawings, elevations, specifications, and other information as may be necessary for the commission to consider the application.
- (3) A permit shall not be issued and proposed work shall not proceed until the commission has acted on the application by issuing a certificate of appropriateness or a notice to proceed as prescribed by this chapter.

8:413. Issuance of permits.

- (1) Prior to the issuance of any permit, the commission shall hold a public hearing in compliance with the Open Meetings Act. Public notice shall be placed in a local newspaper of general circulation prior to the meeting, and shall include a meeting agenda that lists each permit application to be reviewed or considered by the commission.
- (2) The commission shall file certificates of appropriateness, notices to proceed, and denials for applications for permits with the building official within 5 working days of the date of decision.
- (3) A permit shall not be issued until the commission has acted as prescribed by this chapter. If a permit application is denied, the decision shall be binding on the building official.
- (4) For 3 years from the date of issuance of a certificate of appropriateness or notice to proceed, a permit may be issued for work that is consistent with the application approved by the commission. After 3 years no permit shall be issued without a new application being submitted and the commission issuing a new certificate of appropriateness or notice to proceed.

- (5) A denial shall be accompanied with a written explanation by the commission of the reasons for denial and, if appropriate, a notice that an application may be resubmitted for commission review when commission recommended changes have been made. The denial shall also include notification of the applicant's rights of appeal to the state historic preservation review board and to the circuit court.
- (6) The failure of the commission to act within 60 calendar days after the date a complete application is filed with the commission, unless an extension is agreed upon in writing by the applicant and the commission, shall be considered to constitute approval.

8:414. Administrative approval.

The commission may delegate the issuance of certificates of appropriateness for specified minor classes of work to the planning and development services manager or designee. The commission shall provide to the planning and development services manager with specific written standards for issuing certificates of appropriateness under this subsection. On at least a quarterly basis, the commission shall review the certificates of appropriateness, if any, issued by administrative approval in order to determine whether or not the delegated responsibilities should be continued.

8:415. Standard of review.

- (1) In reviewing plans for work, the commission shall follow the United States secretary of the interior's standards for rehabilitation and guidelines for rehabilitating historic buildings, as set forth in 36 CFR part 67, as amended. Design review standards and design guidelines administered by the commission that address special design characteristics of historic districts may be followed if they are approved by City Council, and are equivalent in guidance to the secretary of the interior's standards and guidelines and are established or approved by the SHPO.. The commission shall also consider all of the following:
 - (a) The historic or architectural value and significance of the resource and its relationship to the historic value of the surrounding area.
 - (b) The relationship of any architectural features of the resource to the rest of the resource and to the surrounding area.
 - (c) The general compatibility of the design, arrangement, texture, and materials proposed to be used.
 - (d) Other factors, such as aesthetic value, that the commission finds relevant.
 - (e) Whether the applicant has certified in the application that the property where work will be undertaken has, or will have before the proposed project completion date, a fire alarm system or a smoke alarm complying with the requirements of the Construction Code, as provided in Chapter 100.

- (2) The Commission shall review and act upon only exterior features of a resource, and excepting for noting compliance with the requirement to install a fire alarm system or smoke alarm, shall not review and act upon interior arrangements unless specifically authorized to do so by city council in the ordinance designating the historic district or unless interior work will cause visible change to the exterior of the resource.
The commission shall not disapprove an application due to considerations not prescribed in subsection (1).
- (3) If an application is for work that will adversely affect the exterior of a resource the commission considers valuable to the city, state, or nation, and the commission determines that the alteration or loss of that resource will adversely affect the public purpose of the city, state, or nation, the commission shall attempt to establish with the owner of the resource an economically feasible plan for preservation of the resource.
- (4) The commission shall not issue a certificate of appropriateness unless the applicant certifies in the application that the property where the work will be undertaken has, or will have before the proposed project completion date, a fire alarm system or smoke alarm complying with the requirements of the Construction Code as provided in Chapter 100.

8:416. Notice to proceed.

- (1) Work within a historic district shall be permitted through the issuance of a notice to proceed by the commission if any of the following conditions prevail and if the proposed work can be demonstrated by a finding of the commission to be necessary to substantially improve or correct any of the following conditions:
 - (a) The resource constitutes a hazard to the safety of the public or to the structure's occupants.
 - (b) The resource is a deterrent to a major improvement program that will be of substantial benefit to the community and the applicant proposing the work has obtained all necessary planning and zoning approvals, financing, and environmental clearances.
 - (c) Retaining the resource will cause undue financial hardship to the owner when a governmental action, an act of God, or other events beyond the owner's control created the hardship, and all feasible alternatives to eliminate the financial hardship, which may include offering the resource for sale at its fair market value or moving the resource to a vacant site within the historic district, have been attempted and exhausted by the owner.
 - (d) Retaining the resource is not in the interest of the majority of the community.

8:417. Evidence of undue financial hardship.

- (1) Evidence supporting undue financial hardship shall be submitted by the applicant in conjunction with an application for work as set forth in section 8:415.
- (2) The commission may at its sole discretion solicit expert testimony and/or require that the applicant make submissions concerning any or all of the information set forth below:
 - (a) Estimate of the cost of the proposed construction, alteration, demolition, or removal and an estimate of any additional cost that would be incurred to comply with the recommendations of the commission for changes necessary for the issuance of a notice to proceed;
 - (b) A report from a licensed engineer or architect with experience in rehabilitation as to the structural soundness of any structures on the property and their suitability for rehabilitation;
 - (c) Estimated market value of the property in its current condition; after completion of the proposed construction, alteration, demolition, or removal; after any changes recommended by the commission; and, in the case of a proposed demolition, after renovation of the existing property for continued use;
 - (d) In the case of a proposed demolition, an estimate from an architect, developer, real estate consultant, appraiser, or other real estate professional experienced in rehabilitation as to the economic feasibility or rehabilitation or reuse of the existing structure on the property;
 - (e) Amount paid for the property, the date of purchase, and the party from whom purchased, including a description of the relationship, if any, between the owner of record or applicant and the person from whom the property was purchased, and any terms of financing between the seller and buyer;
 - (f) If the property is income-producing, the annual gross income from the property for the previous 2 years; itemized operating and maintenance expenses for the previous 2 years; and depreciation deduction and annual cash flow before and after debt service, if any, during the same period;
 - (g) Remaining balance on any mortgage or other financing secured by the property and annual debt service, if any, for the previous 2 years;
 - (h) All appraisals obtained within the previous 2 years by the owner or applicant in connection with the purchase, financing, or ownership of the property;

- (i) Any listing of the property for sale or rent, price asked and offers received, if any, within the previous 2 years;
 - (j) Assessed value of the property according to the 2 most recent assessments;
 - (k) Real estate taxes for the previous 2 years;
 - (l) Form of ownership or operation of the property, whether sole proprietorship, for-profit or nonprofit corporation, limited partnership, joint venture, or other;
 - (m) Any other information the owner chooses to provide.
- (3) In the event that any of the information is not reasonably available to the owner, cannot be obtained by the owner, or may not be disclosed without a substantial adverse impact upon the owner, the owner may file with the commission a description of the information which cannot be obtained and describe the reasons why such information cannot be obtained or provided.

8:418. Appeals.

- (1) An applicant aggrieved by a decision of the commission concerning a permit application may file an appeal with the state historic preservation review board within the SHPO. The appeal shall be filed within 60 calendar days after the decision is furnished to the applicant. The appellant may submit all or part of the appellant's evidence and arguments in written form. The review board may affirm, modify, or set aside the commission's decision and may order the commission to issue a certificate of appropriateness or notice to proceed. A permit applicant aggrieved by the decision of the state historic preservation review board may appeal the decision to the circuit court.
- (2) Any resident or duly organized historic preservation organization in the city, as well as resource property owners, jointly or severally aggrieved by a decision of the commission may appeal the decision to the circuit court, except that a permit applicant aggrieved by a decision of the commission may not appeal to the court without first exhausting the right to appeal to the state historic preservation review board.

8:419. Ordinary Maintenance.

Nothing in this chapter shall be construed to prevent ordinary maintenance or repair of a resource within a historic district, or to prevent work on any resource under a permit issued by the building official before this chapter was enacted.

8:420. Demolition by neglect.

- (1) Upon a finding by the commission that a historic resource within a historic district, or proposed historic district subject to its review and approval is threatened with demolition by neglect, the commission may do either of the following:
 - (a) Require the owner of the resource to repair all conditions contributing to demolition by neglect.
 - (b) If the owner does not make repairs within a reasonable time, the commission may request for the city to enter the property and make such repairs as are necessary to prevent demolition by neglect. The costs of the work shall be charged to the owner, and may be levied by the city as a special assessment against the property. The city may enter the property for purposes of this section upon obtaining an order from the circuit court.
- (2) The Commission may find that a resource is being demolished by neglect if any of the following criteria are met:
 - (a) Parts of the resource which are so attached that they may fall and injure members of the public or property.
 - (b) Deteriorated or inadequate foundation.
 - (c) Defective or deteriorated flooring or floor supports or flooring or floor supports of insufficient size to carry imposed loads with safety.
 - (d) Members of walls, partitions or other vertical supports that split, lean or buckle due to defective material or deterioration.
 - (e) Members of walls, partitions or other vertical supports that are of insufficient size to carry imposed loads with safety.
 - (f) Members of ceilings, roofs, ceiling and roof supports or other horizontal members which sag, split or buckle due to defective material or deterioration.
 - (g) Members of ceilings, roofs, ceiling and roof supports or other horizontal members that are of insufficient size to carry imposed loads with safety.
 - (h) Fireplaces or chimneys which list, bulge or settle due to defective material or deterioration.
 - (i) Fireplaces or chimneys which are of insufficient size or strength to carry imposed loads with safety.
 - (j) Deteriorated, crumbling or loose exterior plaster or stucco.

- (k) Deteriorated or ineffective waterproofing of exterior walls, roofs, foundations or floors, including broken windows or doors.
- (l) Defective or lack of weather protection for exterior wall coverings, including lack of paint, or weathering due to lack of paint or other protective covering.
- (m) Any fault or defect in the resource which renders the same structurally unsafe or not properly watertight.
- (n) The deterioration of any significant architectural feature of the resource as determined by the Commission.
- (o) The deterioration or overgrowth of landscape elements that are of historic significance to a resource, or that are endangering the structural stability or waterproofing of a resource.

8:421. Violations and penalties.

- (1) A person, individual, partnership, firm, corporation, organization, institution, or agency of government that violates this chapter is responsible for a civil infraction and is subject to a civil fine of not more than \$5,000.00.
- (2) A person, individual, partnership, firm, corporation, organization, institution, or agency of government that violates this chapter may be ordered by the court to pay the costs to restore or replicate a resource unlawfully constructed, added to, altered, repaired, moved, excavated, or demolished.
- (3) When work has been done upon a resource without a permit, and the commission finds that the work does not qualify for a certificate of appropriateness, the commission may require an owner to restore the resource to the condition the resource was in before the inappropriate work or to modify the work so that it qualifies for a certificate of appropriateness. If the owner does not comply with the restoration or modification requirement within a reasonable time, the commission may request for the city to seek an order from the circuit court to require the owner to restore the resource to its former condition or to modify the work so that it qualifies for a certificate of appropriateness. If the owner does not comply or cannot comply with the order of the court, the commission may request for the city to enter the property and conduct work necessary to restore the resource to its former condition or modify the work so that it qualifies for a certificate of appropriateness in accordance with the court's order. The costs of the work shall be charged to the owner, and may be levied by the city as a special assessment against the property. When acting pursuant to an order of the circuit court, the city may enter a property for purposes of this section.

- (4) At the request of city council or the commission the city attorney is authorized to seek an order from a court of competent jurisdiction to prevent any violation of this chapter or to require that property which has been altered in violation of this chapter be restored.

8:422. Coordination with Washtenaw County.

Coordination between the county historic district commission and the commission shall be maintained. The overall historic preservation plan of the city shall be submitted to the Washtenaw County Historic District Commission for review, and the commission shall review the Washtenaw county historic preservation plan.

Day-to-day activities of the commission will not be reviewed by the Washtenaw County Historic District Commission unless the activities affect resources of importance to the Washtenaw County Historic District Commission.

8:423. City acquisition of historic resources.

If all efforts by the commission to preserve a resource fail, or if it is determined by the city council that public ownership is most suitable, the city council, if considered to be in the public interest, may acquire the resource using public funds, public or private gifts, grants, or proceeds from the issuance of revenue bonds. The acquisition shall be based upon the recommendation of the commission. After receiving a recommendation from the commission, city council may sell resources acquired under this section with protective easements included in the property transfer documents, if appropriate.

8:424. City acceptance of gifts or grants for historic preservation.

The city council may accept state or federal grants for historic preservation purposes, may participate in state and federal programs that benefit historic preservation, and may accept public or private gifts for historic preservation purposes. The city council may make the historic district commission, a standing committee, or other agency its duly appointed agent to accept and administer grants, gifts, and program responsibilities.

8:425. Districts Designated.

Historic districts that were in effect on the date of enactment of this chapter, shall remain in effect, and shall be administered according to the terms, conditions and requirements of this chapter. These historic districts are codified in Sections 8:425.1 through 8:425.13 of this chapter. Properties previously designated by the city as complementary and/or significant shall be considered historic resources under this chapter.

8:425.1. Division Street Historic District.

The boundaries of the Division Street Historic District are as shown on the map on file in the office of the city clerk which is incorporated into and made a part of this chapter, and is comprised of the following described, non-contiguous parcels:

- (1) The easterly 99 feet of the northerly 41.25 feet of Lot 7 and the easterly 16.99 feet of the southerly 16.5 feet of Lot 8 of Block 3 south, R6E in the original plat of the Village (now City) of Ann Arbor, Washtenaw County, Michigan, commonly known as 312 South Division Street (Kempf House);
- (2) The easterly 33 feet of Lot 10 in Block 3 south, R9E in the Ann Arbor Land Company's Addition to the Village (now City) of Ann Arbor, Washtenaw County, Michigan, commonly known as 611 ½ East William Street (Omicron Literary Association);
- (3) Lots 1, 2 and 3 and the westerly half of Lot 4 in the plat of G. Wilcoxson's Land in the City of Ann Arbor and the southerly 40 feet of Lot A in Maynard and Gruner's Addition to the City of Ann Arbor, all in Washtenaw County, Michigan, according to the plats thereof as recorded in the Office of the Register of Deeds for the County of Washtenaw, commonly known as 208 North Division Street (Wells Babcock House);
- (4) Lot 8 and the easterly 50 feet of Lot 7, excepting and reserving therefrom the southerly 107 feet of the westerly 6 feet of said easterly 50 feet of Lot 7, in Block 2 north, R6E of the original plat of the Village (now City) of Ann Arbor, Washtenaw County, Michigan, commonly known as 205 North Division Street (Alonzo Palmer House);
- (5) Lots 1, 2 and 24 of Assessor's Plat No. 8 of the City of Ann Arbor, commonly known as 126 North Division Street (Wilson-Wahr House);
- (6) The north 70 feet of Lot 9 and the north 70 feet of the east 6 feet of Lot 10 in Block 1 north of R6E in the original plat of the Village (now City) of Ann Arbor, Washtenaw County, Michigan, commonly known as 121 North Division Street (Moses Rodgers House);
- (7) The easterly 62 feet of Lot 3 in Block 2 north of R6E in the original plat of the Village (now City) of Ann Arbor, Washtenaw County, Michigan, commonly known as 317 East Ann Street (Corselius House);
- (8) Lot 7 and the northerly 17 feet of Lot 8 in Block 3 of Ormsby and Page's Addition to the Village (now City) of Ann Arbor, Washtenaw County, Michigan, according to the recorded plat thereof, commonly known as 716 North Fifth Avenue (Tice House);
- (9) Lot 1 of Assessor's Plat No. 7 of the City of Ann Arbor, Washtenaw County, Michigan, commonly known as 300 North Division Street (St. Andrew's Episcopal Church); and
- (10) Block 10, Ormsby and Page's Addition, E 1/2 vacated Page Street, Part of Block A, Eastern Addition, SW 1/4 of Section 21 and SW 1/4 of Section 20, T2S, R6E, beginning at the intersection of the east line of North State Street and the north line of High Street extended; thence S 89 degrees, 31' W 187.73 feet; thence N 89 degrees, 48' W 268.74 feet; thence N 04 degrees, 4' E 292.92 feet to the east line of Broadway;

thence N 57 degrees, 5' E 6.90 feet; thence S 61 degrees, 13' E 499.23 feet; thence S 7degrees, 55' W to the Place of Beginning, except that land on which the Railroad Express Building is located. Also, Block 9 of Ormsby and Page's Addition, and parts of Lots 1, 2, and 3, east of the east line of Broadway and NW 52 feet of Lot 4, commonly known as The Michigan Central Depot and surrounding brick streets.

8:425.2. Liberty Street Historic District.

The boundaries of the Liberty Street Historic District are as shown on the map on file in the office of the city clerk which is incorporated into and made a part of this chapter, and is comprised of the following described parcels:

- (1) The east 40 feet of the west 80 feet of Lot 1 and the north 20 feet of the west 80 feet of Lot 2, Block 3 south, R3E, of the original plat of Ann Arbor, commonly known as 117-119 West Liberty Street, (First Walker Building);
- (2) The west 22 feet of the east 44 feet of Lot 1 and the south 24.55 feet of the west 22 feet of the east 44 feet of Lot 2, Block 3 south, R3E, of the original plat of Ann Arbor, commonly known as 115 West Liberty Street, (Second Walker Building);
- (3) The east 22 feet of Lot 1 and the north 18 feet of the east 22 feet of Lot 2, Block 3 south, R3E, of the original plat of Ann Arbor, commonly known as 113 West Liberty Street, (Haarer Building);

8:425.3. Old West Side Historic District.

The boundaries of the Old West Side Historic District are as shown on the map on file in the office of the city clerk which is incorporated into and made a part of this chapter, and is comprised of the following described area:

Commencing at a point in the north line of West Huron Street which is 307.12 feet west of the west line of Arbana for a Place of Beginning; thence northerly parallel to the west line of Arbana 142 feet; thence in an east-northeasterly direction along the north lot lines of the lots fronting on the north side of Huron Street to the west line of Arbana and across Arbana to the north lot lines of the lots fronting on the north side of Huron Street and along the north lines of the said lots and across the north end of the alley to the westerly line of North Seventh Street; thence easterly across North Seventh Street and easterly along the north lot lines of the lots fronting on the north side of Huron Street; thence to the west line of Park View Place; thence across Park View Place to the north lot line of the lot fronting on Huron Street between Park View Place and Chapin Street to the west line of the right-of-way of Chapin Street; thence across Chapin Street to the north lot line of lots fronting on Huron Street and easterly along the said north lot lines from the easterly edge of Chapin Street to the easterly line of Lot 1 of Siple's Subdivision; thence south along the said lot line to the north line of the right-of-way of West Huron Street;

thence southeasterly to the intersection of the south line of the right-of-way of West Huron Street with the west line of the right-of-way of the Ann Arbor Railroad to the centerline of South First Street; thence southerly in the centerline of South First Street to a point which is 327 feet south of the south line of West William Street; thence easterly along the south line of the Fingerle Lumber Company land to the westerly line of the Ann Arbor Railroad right-of-way; thence southerly along the westerly line of the right-of-way of the Ann Arbor Railroad to a point where the said westerly right-of-way line intersects the rear lot line of the lots fronting on the easterly side of South Ashley Street; thence south in the rear lot lines of the lots fronting on South Ashley Street to a point which is 66 feet north of the north line of West Madison Street; thence easterly 37.26 feet; thence southerly 66 feet north to the north line of West Madison Street; thence southwesterly across West Madison Street to a point on the south line of West Madison Street which said point is 113 feet west of the west line of South Main Street; thence south 132 feet; thence west to the east line of the right-of-way of South Ashley Street; thence southwesterly in a straight line to a point which is 166.32 feet west of the west line of South Main Street and which is in the south line of the right-of-way of West Mosley Street; thence south 74 feet; thence east to the west line of South Main Street; thence southerly in the west line of South Main Street to a point which is 40 feet south of the south line of Koch Avenue measured along said line of Koch Avenue; thence northerly 40 feet parallel to the 120 feet parallel to the south line of Koch Avenue; thence northerly 40 feet parallel to the westerly line of South Main Street to the south line of Koch Avenue; thence westerly in the westerly line of South Main Street to the south line of Koch Avenue to the northeast corner of Lot 36 of Koch's Subdivision to the south line of Koch's Subdivision; thence westerly along the south line of Koch's Subdivision and continuing westerly across South First Street and along the south line of G. P. Whaley's Subdivision and across Third Street and along the south line of Assessor's Plat No. 2 to the centerline of Fifth Street; thence northerly in the centerline of Fifth Street to a point which is 149 feet south of the south line of the right-of-way of West Madison Street; thence westerly from the centerline of Fifth Street continuing along the southerly boundary of the lots fronting on the south side of West Madison Street to the point where the east line of South Seventh Street intersects; thence northwesterly to the southeast corner of Lot 12 of Thompson, Spoor and Thompson's Addition; thence west 307.48 feet along the south line of Lot 12; thence north 165 feet parallel to the west line of South Seventh Street; thence east in the north line of Lot 11 to a point which is 132 feet west of the west line of South Seventh Street; thence northerly along the rear lot lines fronting on the west side of South Seventh Street across Lutz Avenue and across Jefferson Court to a point which is 90.75 feet west of the west line of South Seventh Street and 158 feet south of the south line of West Liberty Street; thence westerly along the rear lot lines of the lots fronting on West Liberty Street and across Eighth Street and continuing westerly across Eber White Boulevard and across Crest Avenue to the southwest corner of Lot 37 of Eber White First Addition; thence northerly along the west line of Lot 37 to the south line of the right-of-way of West Liberty Street;

thence northwesterly to a point in the north line of the right-of-way of West Liberty Street and 138.50 feet west-southwest from the west line of Crest Avenue and across Bemidji Drive and across West Washington Street to a point in the south line of the right-of-way of West Huron Street, which is 48.18 feet west of the west line of Crest Avenue; thence northeasterly to the Place of Beginning.

8:425.4. Northern Brewery Historic District.

The boundaries of the Northern Brewery Historic District are as shown on the map on file in the office of the city clerk which is incorporated into and made a part of this chapter, and is comprised of the following described area:

Commencing at the southwesterly corner of Lot 10 of Traver's Addition to the City of Ann Arbor, as recorded in Liber L, page 36, Washtenaw County Records; thence S 55 deg, 52' W 8.0 feet along the southeast line of Lot 9 of said subdivision and the northwest line of Jones Drive for a Place of Beginning; thence N 35 deg, 04' W 132.0 feet parallel with the northeast line of Lot 9 to the northwest line of Lot 9; thence N 44 deg, 11' 30" E 323.75 feet along the southeast line of land belonging to the City of Ann Arbor; thence S 35 deg, 04' E 197.52 feet; thence S 55 deg, 52' W 318.0 feet along the southeast line of Lots 9-16 and the northwest line of Jones Drive to the Place of Beginning, being the northeast 8.0 feet of Lot 9, all of Lots 10-15 and part of Lot 16 of said Traver's Addition, also being Lot 76 and part of Lot 77 of Assessor's Plat No. 48, as recorded in Liber 16, pages 55, 56, and 57, Washtenaw County Records, containing 1.20 acres of land, more or less.

8:425.5. Ann Street Historic Block Historic District.

The boundaries of the Ann Street Historic District are as shown on the map on file in the office of the city clerk which is incorporated into and made a part of this chapter, and is comprised of the following described parcels:

The east half of Lot 4, all of Lots 5, 6, 7, 8, 9 and the southwest portion of Lot 10, being the south 30.5 feet of the west 36 feet of Lot 10, and the west portion of Lot 11, being 36 feet on the north line of Lot 11 and 33 feet on Ann Street, as well as the remainder of Lots 10 and 11, except the area of Lots 10 and 11 north of line extending from a point 2.5 feet south of the northwest corner of Lot 11 to a point 2.5 feet north of the southeast corner of Lot 10, Plat of G. Wilcoxson's Land; also, Lots 3, 4, 5, 6, 7, 8, 9, 10, 11, and 12, Assessor's Plat No. 8, all in the City of Ann Arbor, Washtenaw County, Michigan.

8:425.6. Washtenaw Hill Historic District.

The boundaries of the Washtenaw Hill Historic District are as shown on the map on file in the office of the city clerk which is incorporated into and made a part of this chapter, and shall be comprised of the following described parcels:

- (1) Assessor's Plat No. 26, Lot 2, commonly known as 1530 Hill Street (Baldwin/Hill House);
- (2) Assessor's Plat No. 18, Lot 17, commonly known as 1547 Washtenaw Avenue (Henry Simmons Frieze House);
- (3) Olivia B. Hall Subdivision, Lot 2, commonly known as 1310 Hill Street (Edward deMille Campbell House);
- (4) Olivia B. Hall Subdivision, Lot 7, commonly known as 1410 Hill Street (Freer/Shearer House);
- (5) Assessor's Plat No. 18, Lot 16, commonly known as 1555 Washtenaw Avenue (Campbell/Hays House);
- (6) Olivia B. Hall Subdivision, Lot 1, commonly known as 810 S. Forest Avenue (Lord of Light Lutheran Church);
- (7) R. S. Smith's 2nd Addition, Block 6, the south 125.25 feet of Lots 1 and 2 and the south 125.5 feet of the west 6.5 feet of Lot 3, commonly known as 1315 Hill Street (Amariah Freeman House);
- (8) R.S. Smith's 2nd Addition, Block 6, the south 125.5 feet of the east 60 feet of Lot 3, commonly known as 1319 Hill Street (vacant lot);
- (9) Olivia B. Hall Subdivision, Lot 3, also west 66 feet of Lot 4, commonly known as 1316-22 Hill Street (Alpha Gamma Delta Sorority);
- (10) Olivia B. Hall Subdivision, Lot 5, also the east 11.46 feet of Lot 4, commonly known as 1330 Hill Street (Oscar Robinson House);
- (11) R. S. Smith's 2nd Addition, Block 6, Lot 4, also the west 48 feet of Lot 5, commonly known as 1331 Hill Street (Delta Upsilon Fraternity);
- (12) R. S. Smith's 2nd Addition, Block 6, also the east 18 feet of Lot 5, also Lot 6, commonly known as 1335 Hill Street (Farwell Wilson House);
- (13) Olivia B. Hall Subdivision, Lot 6, commonly known as 1402 Hill Street (Floyd Mecham House);
- (14) Part of land bounded as follows: on west by Ranson S. Smith's 2nd Addition, south by Hill Street, east by Adam's land and Baldwin's Picnic Grove Addition, and north by Presbyterian Church land, being 162 feet more or less on Hill Street, commonly known as 1405 Hill Street (Albert Pattengill House);
- (15) Olivia B. Hall Subdivision, Lots 8 and 9, commonly known as 1416-20 Hill Street (John Rolfe House);

- (16) Part of Lots 4, 5, 12 and 13 bounded on the north by Presbyterian Church land, on the east by Bursley Keene land, on the south by Hill Street and on the west by Cooley land, being 8 rods on Hill Street, J. D. Baldwin's Plat of Picnic Grove, commonly known as 1421 Hill Street (Henry Carter Adams House);
- (17) Beginning at a point on the southerly lines of section 28, 271.7 feet east from the southerly 1/4 post of said section, thence northerly at right angles with Hill Street 237.3 feet to a point 249 feet southwesterly from the center line of Washtenaw Avenue, measured on line at right angles with said Avenue, thence northerly parallel to said center line 202 feet to the southwesterly line of Lot 4, J. D. Baldwin's Plat of Picnic Grove, thence southwesterly along boundary line of Lot 4, 1.4 feet to point from which west boundary of land must run to make 132 feet in width east and west, thence southerly parallel to the east boundary line to said section line, thence east on section line to Place of Beginning except land occupied by Hill Street, part of Lots 5, 6, 11 and 12, J. D. Baldwin's Plat of Picnic Grove, commonly known as 1429 Hill Street (B'nai Brith Hillel/Beth Israel House);
- (18) Olivia B. Hall Subdivision, Lot 10, except the south 56 feet, commonly known as 1430 Hill Street (800 Lincoln) (Kappa Nu Fraternity);
- (19) Assessor's Plat No. 26, Lot 5, commonly known as 1502 Hill Street (Delta Sigma Delta Fraternity);
- (20) Assessor's Plat No. 26, Lot 4, commonly known as 1508-10 Hill Street (Thomas Bogle House);
- (21) Assessor's Plat No. 26, Lot 3, except the south 148 feet, commonly known as 1520-22 Hill Street (John Cutting House); and
- (22) Lot 6, except the northwesterly triangular portion sold to Otto Hans, Lots 9 and 10, and the easterly portion of Lot 11, J. D. Baldwin's Plat of Picnic Grove, commonly known as 1550 Washtenaw Avenue (Phi Kappa Psi).

8:425.7. Cobblestone Farm Historic District.

The boundaries of the Cobblestone Farm Historic District are as shown on the map on file in the office of the city clerk which is incorporated into and made a part of this chapter, and is comprised of the following described area:

The east half of the east half of the southwest quarter of Section 3, T3S, R6E, excepting land conveyed to Arthur R. Drappatz and wife by warranty deed, recorded August 1, 1952, in Liber 602 of Records, page 637, Washtenaw County Records. Also known as 2781 Packard Road, Ann Arbor, Michigan.

8:425.8. Old Fourth Ward Historic District.

The boundaries of the Old Fourth Ward Historic District are as shown on the map on file in the office of the city clerk which is incorporated into and made a part of this chapter, and is comprised of the following described area:

The Following Description lies within the Southeast $\frac{1}{4}$ of Section 20, Northwest $\frac{1}{4}$ of Section 28 and the Northeast $\frac{1}{4}$ of Section 29, Ann Arbor Township, T2S, R6E, in the City of Ann Arbor, Washtenaw County, Michigan.

Beginning at the Northeast corner of Lot 5, B2N, R13E of "Eastern Addition" to the City of Ann Arbor as recorded in Liber 251 of Plats, Page 455, Washtenaw County Records, being a part of the NW $\frac{1}{4}$ of Section 28, T2S, R6E, Ann Arbor Township, in the City of Ann Arbor, Washtenaw County, Michigan, said Northeast corner also being on the westerly line of Glen Avenue (66 ft. wd.) and the southerly line of Catherine Street (66 ft. wd.); Thence westerly along said southerly line of Catherine Street, said southerly line also being the northerly line of Lots 4 and 5, B2N, R13E and Lots 9 and 10, B2N, R12E of said "Eastern Addition" and the northerly line of Lots 1, 2, 3, 4, and 5 of "Wood and Brooks Subdivision No. 2" as recorded in Liber 2 of Plats, Page 38, Washtenaw County Records, to the Northeast corner of Lot 5, B2N, R11E of said "Eastern Addition", said Northeast corner also being the Southwest corner of said Catherine Street and N. Ingalls Street (66 ft. wd.); Thence northerly along the westerly line of said N. Ingalls Street, said westerly line also being the easterly line of Lot 4, B3N, R11E of said "Eastern Addition" and the easterly line of Lots 5 and 6, B3N, R11E and Lots 5, 6, 7, and 8, B4N, R11E of "Lawrence and Maynard's Addition" to the City of Ann Arbor as recorded in Liber 27 of Plats, Page 471, Washtenaw County Records, to the Northeast corner of said Lot 5, B4N, R11E of "Lawrence and Maynard's Addition", said Northeast corner also being the Southwest corner of said N. Ingalls Street and E. Kingsley Street (66 ft. wd.); Thence westerly along the southerly line of said E. Kingsley Street, said southerly line also being the northerly line of Lot 5, B4N, R11E of said "Lawrence and Maynard's Addition", to the Northwest corner of said Lot 5, B4N, R11E; Thence northerly to a point on the northerly line of said E. Kingsley Street, said point being more specifically described as the Southeast corner of Lot 2, B5N, R11E of said "Lawrence and Maynard's Addition"; Thence northerly along the easterly line of said Lot 2, B5N, R11E to the Northeast corner of said lot 2, B5N, R11E; Thence westerly along the northerly line of Lots 2, 1, Lot B, 6 and 5, B5N, R11E, of said "Lawrence and Maynard's Addition", to a point on the northerly line of said Lot 5, B5N, R11E, said point being more specifically described as being on the easterly line (extended) of Lot 4 of Block B of said "Eastern Addition"; Thence northerly along the easterly line of Lots 4, 3, 2, and 1 of Block B of said "Eastern Addition" to the Northeast corner of said Lot 1, of Block B, said Northeast corner also being on the southerly line of Fuller Street (variable width); Thence westerly along the said southerly line of Fuller Street to a point on the easterly line of N. State Street (66 ft. wd.), said point also being the Northwest corner of said Lot 1 of Block B; Thence northerly along the easterly line of said N. State Street (extended) to a point on the northerly line of Depot Street (variable width); Thence northwesterly along the northerly line of said Depot Street to a point on the easterly line of Carey Street (variable width), said point also being on the northerly line of Lot 1, Block 9 of "Ormsby and Page's Addition" to the City of Ann Arbor, as recorded in Liber M of Plats, Pages 191 and 192 of Washtenaw County Records;

Thence southwesterly along the easterly line of said Carey Street, also being the westerly line of Lots 1, 2, 3, 4, 5, and 6 of Block 9 of said "Ormsby and Page's Addition" to the Southwest corner of said Lot 6, Block 9, also being the Northwest corner of said Carey Street and High Street (66 ft. wd.); Thence southwesterly to a point on the westerly line of Detroit Street, said point more particularly being described as the Northeast corner of Lot 125 of "Assessor's Plat No. 29" to the City of Ann Arbor, as recorded in Liber 9 of Plats, Page 20, Washtenaw County Records; Thence northwesterly to the Northwesterly corner of said Lot 125; Thence meandering in a southwesterly course along the westerly and northerly most lines of Lots 124, 123, 122, 121, 120, 119, and 118, of said "Assessor's Plat No. 29" to a point at the Southwest corner of said Lot 118, said point also being on the northerly line of said E. Kingsley Street and 68.22 feet westerly of the westerly line of said Detroit Street; Thence southwesterly to the Northwest corner of Lot 117 of said "Assessor's Plat No. 29", also being the Southeast corner of said E. Kingsley Street and N. Fifth Avenue (66 ft. wd.); Thence southerly along the easterly line of said N. Fifth Avenue to the Northeast corner of said N. Fifth Avenue and Catherine Street (66 ft. wd.), also being the Southwest corner of Lot 148 of said "Assessor's Plat No. 29"; Thence westerly to the Southeast corner of Lot 78 of said "Assessor's Plat No. 29", also being the Northwest corner of said Catherine Street and said N. Fifth Avenue; Thence northerly along the westerly line of said N. Fifth Avenue to the Northeast corner of said Lot 78; Thence westerly to the Northwest corner of said Lot 78, also being the easterly line of said Detroit Street; Thence southwesterly along the easterly line of said Detroit Street to the Northeast corner of said Detroit Street and said Catherine Street, also being the Southwest corner of said Lot 78; Thence southerly to a point on the southerly line of said Catherine Street, said point being more particularly described as the Northwest corner of Lots 5, B2N, R5E of the 'Original Plat' to the City of Ann Arbor as recorded in Liber TNA of Plats, Pages 152 and 153, Washtenaw County Records; Thence southerly along the westerly line of Lots 5, 6, 7, & 8, B2N, R5E, of said "Original Plat" to the Southwest corner of said Lot 8, B2N, R5E, also being on the northerly line of E. Ann Street (66 ft. wd.); Thence easterly along the northerly line of said E. Ann Street, also being along the southerly line of Lot 8, B2N, R5E and Lots 1, 2, and part of 3, B2N, R6E of said "Original Plat" to a point 4 feet east of the Southwest corner of Lot 3, B2N, R6E of said "Original Plat"; Thence northerly along a line 4 feet easterly of and parallel to the westerly line of said Lot 3, B2N, R6E, to the northerly line of said Lot 3, B2N, R6E; Thence easterly along the northerly line of said Lot 3, B2N, R6E to the Northwest corner of Lot 4, B2N, R6E of said "Original Plat"; Thence southerly along the westerly line of said Lot 4, B2N, R6E, to the Southwest corner of said Lot 4, B2N, R6E, also being on the northerly line of said E. Ann Street; Thence easterly along the northerly line of said E. Ann Street, also being the southerly line of Lots 4, 5, 6, and part of Lot 7, B2N, R6E of said "Original Plat" to a point 22 feet easterly of the Southwest corner of said Lot 7, B2N, R6E; Thence northerly parallel to the westerly line of said Lot 7, B2N, R6E to a point 25 feet southerly of and 22 feet easterly of the Northwest corner of said Lot, 7, B2N, R6E; Thence westerly parallel to the northerly line of said Lot 7, B2N, R6E, 6 feet; Thence northerly parallel to the westerly line of said Lot 7, B2N, R6E, 25 feet to the northerly line of said Lot 7, B2N, R6E; Thence easterly along the northerly line of Lots 7 and 8, B2N, R6E of said "Original Plat" to the Northeast corner of said Lot 8, B2N, R6E, also being on the westerly line of N. Division Street (66 ft. wd.); Thence northerly along said westerly line to a point 44 feet northerly of the Southeast corner of Lot 9, B2N, R6E of said "Original Plat";

Thence easterly to a point on the easterly line of said N. Division Street, said point being 63.5 feet southerly of the Northwest corner of Lot A of "Maynard and Gruner's Subdivision", as recorded in Liber 1 of Plats, Page 52, Washtenaw County Records; Thence continuing easterly to a point on the westerly line of Lot 1 of said "Maynard and Gruner's Subdivision", said point being 63.5 feet southerly of the Northwest corner of said Lot 1; Thence southerly along the westerly line of said Lot 1 to the Southwest corner of said Lot 1; Thence easterly along the southerly line of Lots 1, 2, 3, 4, 5, 6, 7, 8, 9, and 10 of said "Maynard and Gruner's Subdivision", also being the northerly line of Lots 3, 4, 5, 6, 7, 8, and 9 of "Plat of G. Wilcoxson Land" to the City of Ann Arbor, as recorded in the Liber 43 of Plats, Page 542, Washtenaw County Records, to the Northeast corner of said Lot 9; Thence southerly along the easterly line of said Lot 9, also being the westerly line of Lot 10 of said "Plat of G. Wilcoxson Land", to a point 30.5 feet northerly of the Southwest corner of said Lot 10; Thence easterly parallel to the southerly line of said Lot 10 to a point 36 feet east of said westerly line of Lot 10, said point being 30.5 feet northerly of the southerly line of said Lot 10; Thence southerly parallel to the westerly line of said Lot 10 to a point on the southerly line of said Lot 10, said point being 36 feet easterly of the Southwest corner of said Lot 10; Thence continuing southerly 2.5 feet; Thence easterly parallel to the northerly line of said Lot 10 to a point on the westerly line of N. State Street (66 ft. wd.), said point also being on the easterly line of Lot 11 of said "Plat of G. Wilcoxson Land", and 2.5 feet southerly of the Northeast corner of said Lot 11; Thence southerly along the westerly line of said N. State Street, also being the easterly line of Lot 11 of said "Plat of G. Wilcoxson Land" and the easterly line of Lots 11, 12, and 13 of the "Assessor's Plat No. 8" to the City of Ann Arbor as recorded in Liber 4 of Plats, Page 38, Washtenaw County Records, to a point 150.41 feet northerly of the Southeast corner of Lot 14 of said "Assessor's Plat No. 8"; Thence westerly parallel to the northerly line of E. Huron Street (74.25 ft. wd.), 57.75 feet; Thence southerly 150 feet to a point on the northerly line of said E. Huron Street, said point being 66 feet westerly of the Southeast corner of said Lot 14; Thence easterly along the southerly line of said Lot 14 to the Southeast corner of said Lot 14, also being the Northwest corner of said E. Huron Street and said N. State Street; Thence continuing easterly along E. Huron Street (now 66 ft. wd.), also being the southerly line of Lots 1, 2, 3, and 4, B1N, R10E, Lots 1, 2, 3 and 4, B1N, R11E of said "Eastern Addition" and the southerly line of Lots 1, 2, 3, 4, and 5 of "Plat of F.J.B. Crane's Subdivision of Block 1 North, Range 12 East, Eastern Addition to Ann Arbor" as recorded in Liber 43 of Plats, Page 148, Washtenaw County Records and the southerly line of Lots 1, 2, 3, and 4 of said "Eastern Addition", to the Southeast corner of Lot 4 of said "Eastern Addition", also being the Northwest corner of said E. Huron Street and Glen Avenue (66 ft. wd.); Thence northerly along the westerly line of said Glen Avenue, also being the easterly line of Lots 4, 5, 6, and 7, B1N, R13E and Lots 8, 7, 6 and 5, B2N, R13E of said "Eastern Addition" to the PLACE OF BEGINNING. Said parcel lies within the Southeast ¼ of Section 20, Northwest ¼ of Section 28 and the Northeast ¼ of Section 29, Ann Arbor Township, T2S R6E, in the City of Ann Arbor, Washtenaw County, Michigan.

8:425.9. Main Street Historic District.

The boundaries of the Main Street Historic District are as shown on the map on file in the office of the city clerk which is incorporated into and made a part of this chapter, and is comprised of the following described blocks and parcels within the Original Plat of Ann Arbor:

- (1) Lots 1 and 2, the south 22 feet of Lot 5, and all of Lots 6 through 8; block 1 south, R3E, commonly known as 117 South Ashley, 112-22 West Washington and 100-206 South Main;
- (2) The west 46 feet of Lot 2, and all of Lots 4 through 8; block 1 south, R5E, commonly known as 200-16 East Huron, 105-13 South Fourth Avenue, 201-23 East Washington, and 120 South Fifth Avenue;
- (3) Lots 5 and 6, the east 80 feet of Lot 7 and the south 9.33 feet of the east 80 feet of Lot 8; block 2 south, R2E, commonly known as 206-18 South Ashley and 208 West Liberty;
- (4) Block 2 south, R3E, commonly known as 207-17 South Ashley, 112-22 West Liberty, 200-24 South Main, and 113-23 West Washington;
- (5) Block 2 south, R4E, commonly known as 201-23 South Main, 113-23 East Liberty, 206-20 South Fourth Avenue, and 106-24 East Washington;
- (6) Block 2 south, R5E, commonly known as 201-21 South Fourth Avenue, 201-93 East Liberty, 208-16 South Fifth Avenue, and 200-20 East Washington
- (7) Lot 1, the north 22 feet of Lot 2, the north 55 feet of Lot 11 and all of Lots 12 through 16; block 3 south, R3E, commonly known as 300-12 South Ashley, 300-34 South Main, and 109-19 West Liberty;
- (8) The east 66 feet of Lots 9 and 10; block 3 south, R2E, commonly known as 303 South Ashley; and
- (9) Lots 1 through 3, the north 44.5 feet of Lot 4 and all of Lot 16; block 3 south, R4E, commonly known as 301-35 South Main and 106-22 East Liberty.

8:425.10. Fourth/Ann Historic District.

The boundaries of the Fourth/Ann Historic District are as shown on the map on file in the office of the city clerk which is incorporated into and made a part of this chapter, and is comprised of the following described blocks and parcels within the Original Plat of Ann Arbor:

- (1) Lot 1, the south 115.5 feet of lot 2 and the south 90 feet of the east 42 feet of lot 3; block 2 north, R4E, commonly known as 109-23 East Ann and 201-11 North Fourth Avenue; and
- (2) Lots 1 through 3; block 2 north, R5E, commonly known as 200-18 North Fourth Avenue and 201-11 East Ann; and

- (3) The north 66 feet of the west 34 feet of lot 3, the north 66 feet of lot 4 and all of lots 5 and 6; block 1 north, R5E, commonly known as 106-22 North Fourth Avenue.

8:425.11. East William Street Historic District.

The boundaries of the East William Historic District are as shown on the map on file in the office of the city clerk which is incorporated into and made a part of this chapter, and is comprised of the following described blocks and parcels within the Original Plat of Ann Arbor:

- (1) The east 99 feet of Lot 5, the south 66 feet of the east 99 feet of Lot 6, the south 90.5 feet of the east 160 feet and the east 99 feet of Lot 7 and the south 16.5 feet of the east 99 feet of Lot 8, Block 3 south, R6E, commonly known as 337 East William, and 312-44 South Division;
- (2) Lots 1 through 7 and the westernmost portions of Lots 8 through 14 that are part of the parcels fronting on South Division; Block 3 south, R7E, commonly known as 307-45 South Division;
- (3) The north 6 feet of Lot 15 and all of Lot 16, Block 4 south, R4E, commonly known as 114 East William and 402 South Fourth Avenue;
- (4) Lots 1 and 2, the north 31.5 feet of Lot 3, the north 11 feet of Lot 15 and all of Lot 16, Block 4 south, R5E, commonly known as 403-09 South Fourth Avenue, 212-14 East William, and 402-04 South Fifth Avenue;
- (5) The north 66 feet of the west 189 feet and the north 82.5 feet of the east 42 feet of Lot 1, the north 59.5 feet of the west 66 feet and the east 165 feet of Lot 8, Block 4 south, R6E, commonly known as 403 South Fifth Avenue, 308-40 East William, and 400-10 South Division; and
- (6) Lots 1 and 2, Block 4 south, R7E, commonly known as 403-09 South Division.

8:425.12. State Street Historic District.

The boundaries of the State Street Historic District are as shown on the map on file in the office of the city clerk which is incorporated into and made a part of this chapter, and is comprised of the following described blocks and parcels:

- (1) Lots 11 through 15, Assessor's Plat No. 27, commonly known as 521-625 East Liberty, and 204-30 South State;

- (2) The north 49.5 feet of Lot 2, all of Lots 3 through 8 and the west 33 feet of Lot 9, Block 2 south, R10E, Eastern Addition and all of J. S. Orr's Subdivision, commonly known as 209-317 South State, and 705-11 North University; and
- (3) Lot 1, the east 24 feet of Lot 2, all of Lots 8 through 15 and the east 116 feet of Lot 16, Block 3 south, R9E, the Ann Arbor Land Company's Addition, commonly known as 329-47 Maynard, 601-21 East William, and 300-42 South State.

8:425.13. East Liberty Historic Block Historic District.

The boundaries of the East Liberty Street Historic District are as shown on the map on file in the office of the city clerk which is incorporated into and made a part of this chapter, and is comprised of the following described blocks and parcels within the Original Plat of Ann Arbor:

- (1) The south 66 feet of the east 44 feet of Lot 2, the west 30 feet of Lot 12 and all of Lots 13 and 14, Block 2 south, R6E, commonly known as 311-25 East Liberty; and
- (2) Lot 1, Block 3 south, R6E, commonly known as 307-11-1/2 South Fifth Avenue, and 302-22 East Liberty.

Section 4. That this ordinance shall become effective 10 days after publication.

(Approved by City Council on March 19, 2007)

- (4) To advise and assist owners of property or structures within historic districts on physical and financial aspects of preservation, renovation, rehabilitation, and reuse, and on procedures for inclusion on the state and national registers of historic places;
- (5) To review and comment on any national register nominations submitted to the commission;
- (6) To inform and educate the citizens of Ann Arbor concerning the historic and architectural heritage of the city by publishing appropriate maps, newsletters, brochures, and pamphlets, and by holding programs and seminars;
- (7) To appoint such citizen advisory committees as may be required from time to time;
- (8) To testify before and provide comments to all boards and commissions, including but not limited to the planning commission and the zoning board of appeals, on any matter affecting historically and architecturally significant property, structures, and area, as requested by a board or commission.
- (9) To confer recognition upon the owners of property or structures by means of certificates, plaques, or markers;
- (10) To develop preservation components in planning efforts undertaken by the city and to recommend such planning components to the planning commission and to the city council;
- (11) To review the current zoning ordinance and recommend to the planning commission and the city council any amendments appropriate for the protection and continued use of historically and architecturally significant property, structures, and areas;
- (12) To work with other interested organizations to record and promote an appreciation of local history and to preserve and designate historic buildings, structures, sites, districts and objects;
- (13) To develop design guidelines for work within historic districts;
- (14) To adopt bylaws and rules of procedure subject to city council approval.
- (15) To hold its meetings in compliance with the Open Meetings Act and to provide public notice of its meetings in accordance with that act;

- (16) To keep records of resolutions, proceedings and actions, and make records available to the public in compliance with the Michigan Freedom of Information Act; and
- (17) To undertake any other action or activity necessary or appropriate to the implementation of its powers and duties or to the implementation of the purpose of this ordinance.

(Ord. No. 11-71, 4-19-71; Ord. No. 14-88, § 1, 3-28-88; Ord. No. 54-89, § 1, 10-2-89)

Section 2. That Chapter 103 of Title VIII of the Code of the City of Ann Arbor be repealed.

Section 3. That Title VIII of the Code of the City of Ann Arbor be amended by adding a new chapter, which new chapter shall be designated as Chapter 103 and shall read as follows:

(Approved by City Council on March 19, 2007.)