

CITY OF ANN ARBOR  
INVITATION TO BID



221 – 253 S. 7th St. Hardscape & Green Infrastructure Improvements

ITB No. 4479

Due Date: Monday, March 13, 2017 at 2:00 p.m.

Ann Arbor Housing Commission

Issued By:

City of Ann Arbor  
Procurement Unit  
301 E. Huron Street  
Ann Arbor, MI 48104

# TABLE OF CONTENTS

<i>TABLE OF CONTENTS</i> .....	<i>TC-1</i>
<i>NOTICE OF PRE-BID CONFERENCE</i> .....	<i>NP-1</i>
<i>INSTRUCTIONS TO BIDDERS</i> .....	<i>IB-1 to 5</i>
<i>INVITATION TO BID</i> .....	<i>ITB-1 to 3</i>
<i>BID FORMS</i> .....	<i>BF-1 to 5</i>
<i>CONTRACT</i> .....	<i>C-Error!</i>
<i>Bookmark not defined. to 4</i>	
<i>BOND FORMS</i> .....	<i>B-1 to 2</i>
<i>GENERAL CONDITIONS</i> .....	<i>GC-1 to 18</i>

<i>APPENDIX</i> .....	<i>APDX-1</i>
<i>City of Ann Arbor Prevailing Wage Declaration Form</i>	
<i>City of Ann Arbor Living Wage Forms</i>	
<i>City of Ann Arbor Vendor Conflict of Interest Disclosure Form</i>	
<i>City of Ann Arbor Non-Discrimination Ordinance Notice and Declaration Form</i>	

## ATTACHMENTS

*Davis-Bacon Act Labor Wage Decision*

## Detailed Specifications

Price and Payment Procedures .....	01 20 00 – Page 1-8
Site Clearing .....	31 10 00 – Page 1-3
Erosion and Sedimentation Controls .....	31 25 00 – Page 1-3
Earth Moving .....	31 20 00 – Page 1-6
Stone Work .....	31 33 00 – Page 1-2
Concrete Pavement .....	32 13 13 – Page 1-4
Permeable Concrete Paver Materials .....	32 14 13.19 – Page 1-9
Planting .....	32 90 02 – Page 1-4
Plant Maintenance and Guarantee Period .....	32 90 03 – Page 1-4

## Drawings

Cover .....	L-1
Demolition and Soil Erosion and Sedimentation Plan .....	L-2
Layout Plan .....	L-3
Grading Plan .....	L-4
Landscape Plan .....	L-5
Details .....	L-6

## **NOTICE OF PRE-BID CONFERENCE**

A pre-bid conference for this project will be held on **9:00 a.m., Friday, March 3, 2017** at the project site: 221-253 S. Seventh Street, Ann Arbor, Michigan 48103.

Attendance at this conference is highly recommended. Administrative and technical questions regarding this project will be answered at this time. The pre-bid conference is for information only. Any answers furnished will not be official until verified in writing by the Financial Service Area, Procurement Unit. Answers that change or substantially clarify the bid will be affirmed in an addendum.

# INSTRUCTIONS TO BIDDERS

## General

Work to be done under this Contract is generally described through the detailed specifications and must be completed fully in accordance with the contract documents. All work to be done under this Contract is located in or near the City of Ann Arbor.

Any Bid which does not conform fully to these instructions may be rejected.

## Preparation of Bids

Bids should be prepared providing a straight-forward, concise description of the Bidder's ability to meet the requirements of the ITB. Bids shall be written in ink or typewritten. No erasures are permitted. Mistakes may be crossed out and corrected and must be initialed and dated in ink by the person signing the Bid.

Bids must be submitted on the "Bid Forms" provided with each blank properly filled in. If forms are not fully completed it may disqualify the bid. No alternative bid will be considered unless alternative bids are specifically requested. If alternatives are requested, any deviation from the specification must be fully described, in detail on the "Alternate" section of Bid form.

Each person signing the Bid certifies that he/she is the person in the Bidder's firm/organization responsible for the decision as to the fees being offered in the Bid and has not and will not participated in any action contrary to the terms of this provision.

## Questions or Clarification on ITB Specifications

All questions regarding this ITB shall be submitted via email. Emailed questions and inquires will be accepted from any and all prospective Bidders in accordance with the terms and conditions of the ITB.

All questions shall be due on or before Wednesday, March 8, 2017 by 2 p.m and should be addressed as follows:

Specification/Scope of Work questions emailed to [jhall@a2gov.org](mailto:jhall@a2gov.org) and  
[sgibb-randall@insite-studio.com](mailto:sgibb-randall@insite-studio.com)

Bid Process and Compliance questions emailed to [cspencer@a2gov.org](mailto:cspencer@a2gov.org)

Any error, omissions or discrepancies in the specification discovered by a prospective contractor and/or service provider shall be brought to the attention of Jennifer Hall at [jhall@a2gov.org](mailto:jhall@a2gov.org) after discovery as possible. Further, the contractor and/or service provide shall not be allowed to take advantage of errors, omissions or discrepancies in the specifications.

## Addenda

If it becomes necessary to revise any part of the ITB, notice of the Addendum will be posted to Michigan Inter-governmental Trade Network (MITN) [www.mitn.info](http://www.mitn.info) and/or City of Ann Arbor web site [www.A2gov.org](http://www.A2gov.org) for all parties to download.

Each Bidder must in its Bid, to avoid any miscommunications, acknowledge all addenda which it has received, but the failure of a Bidder to receive, or acknowledge receipt of; any addenda

shall not relieve the Bidder of the responsibility for complying with the terms thereof.

The City will not be bound by oral responses to inquiries or written responses other than written addenda.

## Bid Submission

All Bids are due and must be delivered to the City of Ann Arbor Procurement Unit on or before **Monday, March 13, 2017 at 2:00 p.m. EST**. Bids submitted late or via oral, telephonic, telegraphic, electronic mail or facsimile **will not** be considered or accepted.

Each Bidder must submit one (1) original Bid and **two (2 )** Bid copies in a sealed envelope clearly marked: **ITB No. 4479, 221 – 253 S. 7th St. Hardscape & Green Infrastructure Improvements**.

### **Bids must be addressed and delivered to:**

City of Ann Arbor  
Procurement Unit,  
c/o Customer Services, 1<sup>st</sup> Floor  
301 East Huron Street  
P.O. Box 8647  
Ann Arbor, MI 48107

All Bids received on or before the Due Date will be publicly opened and recorded immediately. No immediate decisions are rendered.

**The following forms provided within this ITB Document must be included in submitted bids.**

- **City of Ann Arbor Prevailing Wage Declaration of Compliance**
- **City of Ann Arbor Living Wage Ordinance Declaration of Compliance**
- **Vendor Conflict of Interest Disclosure Form**
- **City of Ann Arbor Non-Discrimination Ordinance Declaration of Compliance**

**Bids that fail to provide these completed forms listed above upon bid opening will be rejected as non-responsive and will not be considered for award.**

Hand delivered bids will be date/time stamped/signed by the Procurement Unit at the address above in order to be considered. Normal business hours are 9:00 a.m. to 3:00 p.m. Monday through Friday, excluding Holidays. The City will not be liable to any Bidder for any unforeseen circumstances, delivery or postal delays. Postmarking to the Due Date will not substitute for receipt of the Bid. Each Bidder is responsible for submission of their Bid.

Additional time for submission of bids past the stated due date and time will not be granted to a single Bidder; however, additional time may be granted to all Bidders when the City determines in its sole discretion that circumstances warrant it.

## Award

The City intends to award a Contract(s) to the lowest responsible Bidder(s). On multi-divisional contracts, separate divisions may be awarded to separate Bidders. The City may also utilize alternatives offered in the Bid Forms, if any, to determine the lowest responsible Bidder on each division, and award multiple divisions to a single Bidder, so that the lowest total cost is achieved for the City. For unit price bids, the Contract will be awarded based upon the unit prices and the

lump sum prices stated by the bidder for the work items specified in the bid documents, with consideration given to any alternates selected by the City. If the City determines that the unit price for any item is materially different for the work item bid than either other bidders or the general market, the City, in its sole discretion, in addition to any other right it may have, may reject the bid as not responsible or non-conforming.

The acceptability of major subcontractors will be considered in determining if a Bidder is responsible. In comparing Bids, the City will give consideration to alternate Bids for items listed in the bid forms. All key staff and subcontractors are subject to the approval by the City.

## Official Documents

The City of Ann Arbor officially distributes bid documents from the Procurement Unit or through the Michigan Intergovernmental Trade Network (MITN). Copies of the bid documents obtained from any other source are not Official copies. Addenda and other bid information will only be posted to these official distribution sites. If you obtained City of Ann Arbor Bid documents from other sources, it is recommended that you register on [www.MITN.info](http://www.MITN.info) and obtain an official Bid.

## Bid Security

Each bid must be accompanied by a certified check, or Bid Bond by a surety licensed and authorized to do business within the State of Michigan, in the amount of 5% of the total of the bid price.

## Withdrawal of Bids

After the time of opening, no Bid may be withdrawn for the period of sixty (60) days

## Contract Time

Time is of the essence in the performance of the work under this Contract. The available time for work under this Contract is indicated on page C-2, Article III of the Contract. If these time requirements cannot be met, the Bidder must stipulate on Bid Form Section 3 - Time Alternate its schedule for performance of the work. Consideration will be given to time in evaluating bids.

## Liquidated Damages

A liquidated damages clause, as given on page C-2, Article III of the Contract, provides that the Contractor shall pay the City as liquidated damages, and not as a penalty, a sum certain per day for each and every day that the Contractor may be in default of completion of the specified work, within the time(s) stated in the Contract, or written extensions.

Liquidated damages clauses, as given in the General Conditions, provide further that the City shall be entitled to impose and recover liquidated damages for breach of the obligations under Chapter 112 of the City Code.

The liquidated damages are for the non-quantifiable aspects of any of the previously identified events and do not cover actual damages that can be shown or quantified nor are they intended to preclude recovery of actual damages in addition to the recovery of liquidated damages.

## Human Rights Information

All contractors proposing to do business with the City shall satisfy the contract compliance

administrative policy adopted by the City Administrator in accordance with the Section 9:158 of the Ann Arbor City Code. Breach of the obligation not to discriminate as outlined in Section 5, beginning at page GC-3 shall be a material breach of the contract. Contractors are required to post a copy of Ann Arbor's Non-Discrimination Ordinance attached at all work locations where its employees provide services under a contract with the City.

## Wage Requirements

Section 4, beginning at page GC-2, outlines the requirements for payment of prevailing wages and for payment of a "living wage" to employees providing service to the City under this contract. The successful bidder and its subcontractors must comply with all applicable requirements and provide documentary proof of compliance when requested.

For laborers whose wage level are subject to federal, state and/or local prevailing wage law the appropriate Davis-Bacon wage rate classification is identified based upon the work including within this contract. **The wage determination(s) current on the date 10 days before bids are due shall apply to this contract.** The U.S. Department of Labor (DOL) has provided explanations to assist with classification in the following resource link: [www.wdol.gov](http://www.wdol.gov)

## Conflict Of Interest Disclosure

The City of Ann Arbor Purchasing Policy requires that prospective Vendors complete a Conflict of Interest Disclosure form. A contract may not be awarded to the selected Vendor unless and until the Procurement Unit and the City Administrator have reviewed the Disclosure form and determined that no conflict exists under applicable federal, state, or local law or administrative regulation. Not every relationship or situation disclosed on the Disclosure Form may be a disqualifying conflict. Depending on applicable law and regulations, some contracts may awarded on the recommendation of the City Administrator after full disclosure, where such action is allowed by law, if demonstrated competitive pricing exists and/or it is determined the award is in the best interest of the City. A copy of the Vendor Conflict of Interest Disclosure Form is attached.

## Major Subcontractors

The Bidder shall identify on Bid Form Section 4 each major subcontractor it expects to engage for this Contract if the work to be subcontracted is 15% or more of the bid sum or over \$50,000, whichever is less. The Bidder also shall identify the work to be subcontracted to each major subcontractor. The Bidder shall not change or replace a subcontractor without approval by the City.

## Debarment

Submission of a Bid in response to this ITB is certification that the Bidder is not currently debarred, suspended, proposed for debarment, and declared ineligible or voluntarily excluded from participation in this transaction by any State or Federal departments or agency. Submission is also agreement that the City will be notified of any changes in this status.

## Disclosures

After bids are opened, all information in a submitter's bid is subjected to disclosure under the provisions of Michigan Public Act No. 442 of 1976, as amended (MCL 15.231 et seq.) known as the "Freedom of Information Act." The Freedom of Information Act also provides for the complete disclosure of contracts and attachments thereto except where specifically exempted.

## Bid Protest

All Bid protests must be in writing and filed with the Purchasing Agent within five (5) business days of the award action. The bidder must clearly state the reasons for the protest. If a bidder contacts a City Service Area/Unit and indicates a desire to protest an award, the Service Area/Unit shall refer the bidder to the Purchasing Agent. The Purchasing Agent will provide the bidder with the appropriate instructions for filing the protest. The protest shall be reviewed by the City Administrator or designee whose decision shall be final.

## Cost Liability

The City of Ann Arbor assumes no responsibility or liability for costs incurred by the Bidder prior to the execution of a contract with the City. By submitting a bid, a bidder agrees to bear all costs incurred or related to the preparation, submission and selection process for the bid.

## Reservation of Rights

The City of Ann Arbor reserves the right to accept any bid or alternative bid proposed in whole or in part, to reject any or all bids or alternatives bids in whole or in part and to waive irregularity and/or informalities in any bid and to make the award in any manner deemed in the best interest of the City.



# INVITATION TO BID

City of Ann Arbor  
Guy C. Larcom Municipal Building  
Ann Arbor, Michigan 48107

Ladies and Gentlemen:

The undersigned, as Bidder, declares that this Bid is made in good faith, without fraud or collusion with any person or persons bidding on the same Contract; that this Bidder has carefully read and examined the bid documents, including City Nondiscrimination requirements and Declaration of Compliance Form, Living Wage requirements and Declaration of Compliance Form, Prevailing Wage requirements and Declaration of Compliance Form, Vendor Conflict of Interest Form, Notice of Pre-Bid Conference, Instructions to Bidders, Bid, Bid Forms, Contract, Bond Forms, General Conditions, Standard Specifications, Detailed Specifications, all Addenda, and the Plans (if applicable) and understands them. The Bidder declares that it conducted a full investigation at the site and of the work proposed and is fully informed as to the nature of the work and the conditions relating to the work's performance. The Bidder also declares that it has extensive experience in successfully completing projects similar to this one.

The Bidder acknowledges that it has not received or relied upon any representations or warrants of any nature whatsoever from the City of Ann Arbor, its agents or employees, and that this Bid is based solely upon the Bidder's own independent business judgment.

The undersigned proposes to perform all work shown on the plans or described in the bid documents, including any addenda issued, and to furnish all necessary machinery, tools, apparatus, and other means of construction to do all the work, furnish all the materials, and complete the work in strict accordance with all terms of the Contract of which this Bid is one part.

In accordance with these bid documents, and Addenda numbered \_\_\_\_\_, the undersigned, as Bidder, proposes to perform at the sites in and/or around Ann Arbor, Michigan, all the work included herein for the amounts set forth in the Bid Forms.

The Bidder declares that it has become fully familiar with the liquidated damage clauses for completion times and for compliance with City Code Chapter 112, understands and agrees that the liquidated damages are for the non-quantifiable aspects of non-compliance and do not cover actual damages that may be shown and agrees that if awarded the Contract, all liquidated damage clauses form part of the Contract.

The Bidder declares that it has become fully familiar with the provisions of Chapter 14, Section 1:320 (Prevailing wages) and Chapter 23 (Living Wage) of the Code of the City of Ann Arbor and that it understands and agrees to comply, to the extent applicable to employees providing services to the City under this Contract, with the wage and reporting requirements stated in the City Code provisions cited. Bidder certifies that the statements contained in the City Prevailing Wage and Living Wage Declaration of Compliance Forms are true and correct. Bidder further agrees that the cited provisions of Chapter 14 and Chapter 23 form a part of this Contract.

The Bidder declares that it has become familiar with the City Conflict of Interest Disclosure Form and certifies that the statement contained therein is true and correct.

The Bidder encloses a certified check or Bid Bond in the amount of 5% of the total of the Bid Price. The Bidder agrees both to contract for the work and to furnish the necessary Bonds and insurance documentation within 10 days after being notified of the acceptance of the Bid.

If this Bid is accepted by the City and the Bidder fails to contract and furnish the required Bonds and insurance documentation within 10 days after being notified of the acceptance of this Bid, then the Bidder shall be considered to have abandoned the Contract and the certified check or Bid Bond accompanying this Bid shall become due and payable to the City.

If the Bidder enters into the Contract in accordance with this Bid, or if this Bid is rejected, then the accompanying check or Bid Bond shall be returned to the Bidder.

In submitting this Bid, it is understood that the right is reserved by the City to accept any Bid, to reject any or all Bids, to waive irregularities and/or informalities in any Bid, and to make the award in any manner the City believes to be in its best interest.

SIGNED THIS \_\_\_\_\_ DAY OF \_\_\_\_\_, 201\_.

\_\_\_\_\_  
Bidder's Name

\_\_\_\_\_  
Authorized Signature of Bidder

\_\_\_\_\_  
Official Address

\_\_\_\_\_  
(Print Name of Signer Above)

\_\_\_\_\_  
Telephone Number

\_\_\_\_\_  
Email Address for Award Notice

**LEGAL STATUS OF BIDDER**

(The Bidder shall fill out the appropriate form and strike out the other three.)

Bidder declares that it is:

\* A corporation organized and doing business under the laws of the State of \_\_\_\_\_, for whom \_\_\_\_\_, bearing the office title of \_\_\_\_\_, whose signature is affixed to this Bid, is authorized to execute contracts.

**NOTE: If not incorporated in Michigan, please attach the corporation's Certificate of Authority**

• A limited liability company doing business under the laws of the State of \_\_\_\_\_, whom \_\_\_\_\_ bearing the title of \_\_\_\_\_ whose signature is affixed to this proposal, is authorized to execute contract on behalf of the LLC.

\* A partnership, organized under the laws of the state of \_\_\_\_\_ and filed in the county of \_\_\_\_\_, whose members are (list all members and the street and mailing address of each) (attach separate sheet if necessary):

\_\_\_\_\_  
\_\_\_\_\_  
\_\_\_\_\_  
\_\_\_\_\_  
\_\_\_\_\_

\* An individual, whose signature with address, is affixed to this Bid: \_\_\_\_\_  
(initial here)

**Authorized Official**

\_\_\_\_\_ **Date** \_\_\_\_\_, 201\_

(Print) Name \_\_\_\_\_ Title \_\_\_\_\_

Company: \_\_\_\_\_

Address: \_\_\_\_\_

Contact Phone ( ) \_\_\_\_\_ Fax ( ) \_\_\_\_\_

Email \_\_\_\_\_

# BID FORM

## Section 1 – Schedule of Prices

Company: \_\_\_\_\_

Project: **221 – 253 S. 7th St. Hardscape & Green Infrastructure Improvements**

Bidder will complete the Work in accordance with the Contract Documents for the following price(s):

<u>Item</u>		
<u>No.</u>	<u>Description</u>	<u>Lump Sum</u>
1	Mobilization	\$ _____
2	Demolition	\$ _____
3	Soil Erosion Control	\$ _____
4	Earthwork	\$ _____
5	Stone Work	\$ _____
6	Pavement	\$ _____
7	Site Utilities	\$ _____
8	Planting	\$ _____
9	Plant Maintenance and Guarantee	\$ _____

### Base Bid –

For the entire work outlined in these documents for **221 – 253 S. 7th St. Hardscape & Green Infrastructure Improvements**, complete as specified, using equipment and materials only of the type and manufacturers where specifically named.

Total Lump Sum from above \_\_\_\_\_ (\$ \_\_\_\_\_)

The above contract prices are used as the Base Bid. The Base Bid is based on the quantities listed below for each site. Adjustments to the quantities shall be based on the prices provided by the Bidder/Contractor below. The prices provided must be consistent with the Base Bid or the Owner has the right to reject the proposal.

Erosion Control, Inlet Filter	EA	\$
Erosion Control, Silt Fence	LF	\$
Erosion Control Blanket	SY	\$
Construction Fence	LF	\$
Asphalt Pavement, Remove and Dispose	SY	\$

Concrete Pavement, Remove and Dispose		SY	\$
Clear and Grub Existing Brush		SY	\$
Remove and Dispose Existing Tree		EA	\$
Remove and Dispose Existing Shrub		EA	\$
Strip and Stockpile Topsoil		CY	\$
Rough Grade		CY	\$
Removal of Excess Excavated Material		CY	\$
Import Additional Topsoil		CY	\$
Clay Berm		CY	\$
Cobble Swales		LF	\$
Cobble Spillways		LF	\$
PVC Storm Line		LF	\$
Storm Inlet		EA	\$
Concrete Walk		SF	\$
Concrete Steps		LF	\$
Concrete Drive Approach		SF	\$
Concrete Testing		LS	\$
Permeable Pavers		SF	\$
Concrete Edge		LF	\$
Concrete Straight Curb with Outlets		LF	\$
Concrete Curb and Gutter		LF	\$
Stone Wall		FF	\$
Handrail		LF	\$
Stepping Stones		EA	\$
Rain Garden Soil Mix		CY	\$
Existing Topsoil Placement for Landscape Beds		CY	\$
Tree and Shrub Planting			
<i>Amelanchier grandiflora</i>	5 gallon	EA	\$
<i>Buxus 'Green Velvet'</i>	12-15" pot	EA	\$
<i>Clethra alnifolia 'Hummingbird'</i>	#3 cont.	EA	\$
<i>Cornus sericea</i>	1 gallon	EA	\$
<i>Fothergilla gardenii</i>	# 3 cont.	EA	\$
Perennial and Native Plug Planting			
<i>Echinacea purpurea</i>	Native plug	EA	\$
<i>Fragaria virginiana</i>	Native plug	EA	\$
<i>Iris virginica</i>	Native plug	EA	\$
<i>Lysimachia clethroides</i>	Native plug	EA	\$
<i>Penstemon digitalis</i>	Native plug	EA	\$
<i>Physostegia virginiana</i>	Native plug	EA	\$
<i>Potentilla simplex</i>	Native plug	EA	\$
Mulch (beyond amount associated with each plant)		CY	\$

Lawn	SY	\$
Erosion Control Blanket	SY	\$
Two-Year Plant Maintenance and Guarantee	LS	\$
Erosion Control Permits	EA	\$
Right-of-Way Permit	EA	\$

Bidder acknowledges that estimated quantities are not guaranteed, and are solely for the purpose of comparison of Proposals, and final payment for all Unit Price Proposal items will be based on actual quantities, determined as provided in the Contract Documents.

## BID FORM

### Section 2 - Material and Equipment Alternates

The Base Bid proposal price shall include materials and equipment selected from the designated items and manufacturers listed in the bidding documents. This is done to establish uniformity in bidding and to establish standards of quality for the items named.

If the Contractor wishes to quote alternate items for consideration by the City, it may do so under this Section. A complete description of the item and the proposed price differential must be provided. Unless approved at the time of award, substitutions where items are specifically named will be considered only as a negotiated change in Contract Sum.

<u>Item Number</u>	<u>Description</u>	<u>Add/Deduct Amount</u>
--------------------	--------------------	--------------------------

If the Bidder does not suggest any material or equipment alternate, the Bidder **MUST** complete the following statement:

For the work outlined in this request for bid, the bidder does NOT propose any material or equipment alternate under the Contract.

Signature of Authorized Representative of Bidder \_\_\_\_\_ Date \_\_\_\_\_

## BID FORM

### Section 3 - Time Alternate

If the Bidder takes exception to the time stipulated in Article III of the Contract, Time of Completion, page C-2, it is requested to stipulate below its proposed time for performance of the work. Consideration will be given to time in evaluating bids.

If the Bidder does not suggest any time alternate, the Bidder **MUST** complete the following statement:

For the work outlined in this request for bid, the bidder does NOT propose any time alternate under the Contract.

Signature of Authorized Representative of Bidder \_\_\_\_\_ Date \_\_\_\_\_

# BID FORM

## Section 4 - Major Subcontractors

For purposes of this Contract, a Subcontractor is anyone (other than the Contractor) who performs work (other than or in addition to the furnishing of materials, plans or equipment) at or about the construction site, directly or indirectly for or on behalf of the Contractor (and whether or not in privity of Contract with the Contractor), but shall not include any individual who furnishes merely the individual's own personal labor or services.

Contractor agrees that all subcontracts entered into by the Contractor shall contain similar wage provision to Section 4 of the General Conditions covering subcontractor's employees who perform work on this contract.

For the work outlined in these documents the Bidder expects to engage the following major subcontractors to perform the work identified:

<u>Subcontractor (Name and Address)</u>	<u>Work</u>	<u>Amount</u>
---	-------------	---------------

If the Bidder does not expect to engage any major subcontractor, the Bidder **MUST** complete the following statement:

For the work outlined in this request for bid, the bidder does NOT expect to engage any major subcontractor to perform work under the Contract.

Signature of Authorized Representative of Bidder \_\_\_\_\_ Date \_\_\_\_\_



# BID FORM

## Section 5 – References

Include a minimum of 3 reference from similar project completed within the past 5 years.

1) \_\_\_\_\_  
Project Name                      Cost                      Date Constructed

\_\_\_\_\_                      \_\_\_\_\_  
Contact Name                      Phone Number

2) \_\_\_\_\_  
Project Name                      Cost                      Date Constructed

\_\_\_\_\_                      \_\_\_\_\_  
Contact Name                      Phone Number

3) \_\_\_\_\_  
Project Name                      Cost                      Date Constructed

\_\_\_\_\_                      \_\_\_\_\_  
Contact Name                      Phone Number

**CONTRACT**  
**BETWEEN**  
**THE ANN ARBOR HOUSING COMMISSION**  
**AND**  
**CONTRACTOR**

**INTRODUCTION**

**This contract by and between the Ann Arbor Housing Commission hereinafter ("AAHC"), and CONTRACTOR Inc. (hereinafter "CONTRACTOR Inc." or "the Contractor") is hereby entered into this DATE.**

Services pursuant to this contract **shall begin DATE, and shall end no later than DATE** unless otherwise extended, modified, terminated or renewed by the parties as provided for within this contract. Unless otherwise detailed herein, all references to "days" shall be calendar days (in the case that the last day referenced falls on a Saturday, Sunday or legal holiday, then the period of time shall be automatically extended to include the next work day). Also, whenever the term "herein" is referred to, such refers to this contract form, the appendices and all listed attachments.

**1.0 Definitions:**

- 1.1 Housing Commission (HC):** Any reference herein or within any Appendix to the "Housing Commission" shall be interpreted to mean the same as the AAHC.
- 1.2 Purchasing Manager (PM):** The HC Purchasing Manager, acting on behalf of the HC.

**2.0 Services and Payment:**

**2.1 Scope of Services:**  
**Scope of Work for ...**

- 2.2 Provisions of any and all Work (Task Orders):** The Contractor shall not begin any additional work (other than that already detailed herein) without the receipt of a completed Contract Task Order Form (CTOF) from the authorized AAHC representative. This shall be completed as follows:

**2.3 Cost/Value of Services:**

- 2.3.1 Contract Value: The current total Not-To-Exceed (NTE) value of this contract is: \$XX** Any other services provided related to this contract shall be as negotiated between contractor and the AAHC.

The Contractor exceeds the NTE amount at his/her own risk. The Contractor is under no obligation to provide additional services that would cause the Contractor's fees to exceed the NTE amount without prior revision of this amount by written change order.

- 2.4 Renewal Options:** There are no renewal options with this contract.

- 2.5 Time Performance:** The Contractor will complete each assigned task as detailed within the executed Scope of Services.

**2.6 Billing Method:**

- 2.6.1** To receive payment for services rendered pursuant to this contract the Contractor shall submit a fully completed invoice for work previously performed to:

**Ann Arbor Housing Commission  
Attn. Accounts Payable  
727 Miller Avenue  
Ann Arbor, MI 48103**

**2.6.2** At a minimum, the invoice shall detail the following information:

- 2.6.2.1** Unique invoice number;
- 2.6.2.2** Contractor's name, address and telephone number;
- 2.6.2.3** Date of invoice and/or billing period;
- 2.6.2.4** Applicable Purchase Order No.;
- 2.6.2.5** Brief description of services rendered, including applicable time frame, total hours being billed for each service at each detailed site, and at the approved rate (may be submitted in the form of a report or invoice);
- 2.6.2.6** If applicable, Task Order, approved by the HC Executive Director; and
- 2.6.2.7** Total dollar amount being billed.

**2.6.3** The HC will pay each such properly completed invoice received on a **Net/30 basis**. Any invoice received not properly completed will not be paid unless and/or until the Contractor complies with the applicable provisions of this contract.

**3.0** HC's Obligations: Pursuant to this contract, the HC agrees to provide the specific services detailed herein and also shall be responsible for the following:

**3.1** The HC agrees to not provide to the Contractor any assigned work to the Contractor outside the scope of services without the prior written approval of the HC's Executive Director.

**4.0** Contractor's Obligations: Pursuant to this contract, the Contractor agrees to provide the specific services detailed herein and also shall be responsible for the following:

**4.1** **Supervision and Oversight:** The Contractor shall be solely responsible for providing supervision and oversight to all of the Contractor's personnel that are assigned to the HC properties pursuant to this contract.

**4.2** **Qualified Personnel:** The Contractor warrants and represents that it will assign only qualified personnel to perform the services outlined herein and within the appendices. For the purposes of this contract, the term "qualified personnel" shall mean those personnel that have been investigated, tested and trained in the manner described within this contract and, as proposed by the Contractor within its proposal or as provided by the Contractor during the Contractor's normal conduct of business.

**4.3** **Compliance with Federal and State Laws:** All work performed by the Contractor, pursuant to this contract, shall be done in accordance with applicable all Federal, State and local laws, regulations, codes and ordinances.

**4.4** **Contractor's Employees:** There will be a pre-employment background check conducted by the contractor/employer of all personnel prior to them being employed on City Properties. The contractor will be required to verify previous employers and references listed in the employment application.

**4.5** **Security:** The following security standard should be used to determine whether or not an employee should be assigned to work in high security areas as designated by the City:

**Standard (A.–C.):**

- A. Any felony or misdemeanor conviction involving theft, murder or assault in the last five years: May be allowed to work in a high security area if the department is notified in advance and agrees to said agreement.
- B. Any other criminal conviction: May be allowed to work in another department if that department's Director is notified in advance and agrees to said assignment.
- C. Assignment restriction: May not be allowed into a high security area.

**4.5.1** Contractor will have all employees bonded for any losses while employed and assigned to the City of Ann Arbor properties.

**4.5.2** The "City" will have the right to require the contractor to remove any employee deemed incompetent, careless or otherwise objectionable, or any personnel whose actions or appearance are deemed inconsistent with the best interests of the "City". The decision of the City of Ann Arbor, acting through the contract Administrator, or his/her authorized representative, shall be final as to what constitutes incompetent or deviant behavior.

**4.5.3** It is assumed that all employees employed by the contractor will have the requisite skills to perform their designated tasks. Necessary training shall be performed at the contractor's expense and untrained individuals will not be brought into the premises for so-called "ON THE JOB" training. Employees of the contractor will eat and take work breaks in designated areas and will not be allowed to eat in offices. Employees of the contractor will not use city telephones, except for the pay telephones at the various locations. The City of Ann Arbor will charge back all long distance charges for calls made by the contractor's employees. The contractor will not pay his employees less than the minimum wage guidelines of the Federal Government.

**4.6 Insurance Requirements:**

**4.4.1** The complete indemnity requirements are detailed within Section 11 herein.

**4.4.2** The contractor will secure and maintain during the term of the contract insurance from an insurance company authorized to do business in the State of Michigan that will protect contractors and subcontractors and the City from all liability (public liability, personal injury and property damage) claims which may arise from operations under the contract. In this regard, the Contractor shall maintain the following insurance coverage during the effective term(s) of this contract:

**4.4.2.1** The contractor will furnish insurance certificates within seven (7) days of being notified of acceptance of his/her bid. Execution of this contract will not occur until evidence of all required insurance has been submitted and approved by the City.

**4.4.2.2** Failure to maintain the above-reference insurance coverage, including naming the HC as an additional insured (where appropriate) during the term(s) of this contract shall constitute a material breach thereof. The contractor must cease work if any of the required insurance is canceled or expires.

**4.4.2.3** Copies of certificates of insurance shall be submitted to, and approved by, the City prior to the execution of the contract.

- 4.4.2.4 The Certificate shall specifically name the City and the Ann Arbor Housing Commission as additional insured parties. **In the area for the listing of additional insured on the binder it must read: "The City of Ann Arbor, acting by and through the Ann Arbor Housing Commission."**
- 4.4.2.5 The certificates must contain the agreement of the insurance company notifying the City ten (10) days prior to any cancellation or material alteration of the policy. **The cancellation clause must have the language "will mail" and "but failure to mail such notice shall impose no obligation or liability of any kind upon the company, its agents or representatives" removed from this clause.**
- 4.4.2.6 The contractor shall not allow any work under the contract to be performed by a subcontractor unless evidence of similar insurance covering the activities of the subcontractor is submitted to and approved by the City.
- 4.4.2.7 **The limits of insurance shall not be less than the following:**
  - 4.4.2.7.1 Policy of General Liability Insurance, \$1,000,000 per occurrence, \$1,000,000 aggregates together with damage to premises and fire damage of \$50,000 and medical expenses for any one person of \$5,000 with a deductible not greater than \$1,000. The HC shall be named upon the certificate issued as an "additional insured," together with providing a copy of the corresponding endorsement evidencing the same.
  - 4.4.2.7.2 Automobile Liability coverage in a combined single limit of \$1,000,000. For every vehicle utilized during the term of this contract, when not owned by the entity, each vehicle must have evidence of automobile insurance coverage with limits of no less than \$50,000/\$100,000 and medical pay of \$5,000 with a deductible not greater than \$1,000.
  - 4.4.2.7.3 Worker's compensation coverage evidencing carrier and coverage amount required by the State of Michigan.
  - 4.4.2.7.4 Insurance certificate(s)/endorsement(s) shall be delivered to the following person representing the HC:

**ANN ARBOR HOUSING COMMISSION  
FINANCIAL DEPARTMENT  
727 Miller Avenue  
ANN ARBOR, MI 48103**

- 5.0 **Modification:** This contract shall not be modified, revised, amended or extended except by written addendum, executed by both parties.
- 6.0 **Severability:** The invalidity of any provision of this contract, as determined by a court of competent jurisdiction and/or HUD, shall in no way affect the validity of any other provision herein.
- 7.0 **Applicable Laws:**

**7.1 Compliance with Federal and State Laws:** All work performed by the Contractor, pursuant to this contract, shall be done in accordance with applicable all Federal, State and local laws, regulations, codes and ordinances.

**7.2 Jurisdiction of Law:** The laws of the State of Michigan shall govern the validity, construction and effect of this contract, unless said laws supersede, or in conflict with applicable federal laws and/or federal regulations. This contract will be binding upon the parties, their heirs, beneficiaries, and devisees of the parties hereto. The parties agree that Washtenaw County, Michigan is the appropriate forum for any action relating to this contract. Should any party hereto retain counsel for the purpose of initiating litigation or arbitration to enforce, prevent the breach of any provision hereof, or for any other judicial remedy, then the prevailing party shall be entitled to be reimbursed by the losing party for all costs and expenses incurred thereby, including, but not limited to, reasonable attorneys fees and costs incurred by such prevailing party. This contract may be signed in counterparts.

**8.0 Notices, Invoices and Reports:**

**8.1** All notices, reports and/or invoices submitted to the HC by the Contractor pursuant to this contract shall be in writing and delivered to the attention of the following person representing the HC:

**ANN ARBOR HOUSING COMMISSION  
727 Miller Avenue  
ANN ARBOR, MI 48103  
734-794-6720 or if appropriate, faxed to: 734-994-0781**

**8.2** All notices submitted to the Contractor pursuant to this contract shall be in writing and mailed to the attention of:

**CONTRACTOR INFO**

**9.0 Disputed Billings (Charges):**

**9.1 Procedures:** In addition to the procedures detailed within Form HUD-5370-C (10/2006), *General Conditions for Non-Construction Contracts, Section II (With or without Maintenance)*, attached hereto, in the event that the HC disputes any portion of its billing(s), the HC shall pay the undisputed portion of such billing and initiate the dispute-resolving procedures, as follows:

**9.1.1** The HC's representative shall, within 10 days after the HC's receipt of such billing, formally notify the contractor's representative of all particulars pertaining to the dispute, and request that he/she investigate and respond to this issue.

**9.1.2** If such dispute cannot be resolved by the contractor's response, within 10 days after such notification is given, the HC PM and the contractor's representative shall meet to discuss the matter and attempt to arrive at a resolution.

**9.1.3** If the HC PM and the contractor's representative are unable to resolve the dispute through such discussion within 10 days, the HC shall refer the dispute for arbitration with the HC Attorney, within 10 days thereafter, either:

- 9.1.3.1** pay the disputed charges and reserve the right to submit the matter to the appropriate district court in the State of Michigan if the disputed amount does not exceed \$40,000.00.
- 9.1.3.2** not pay the disputed charge and submit the matter to the appropriate district court in the State of Michigan if the disputed amount does not exceed \$40,000.00.
- 9.1.3.3** not pay the disputed charge and allow the Contractor submit the matter to the appropriate district court in the State of Michigan if the disputed amount does not exceed \$40,000.00.
- 9.1.3.4** The decision from arbitration will be binding upon both parties. If the decision is adverse to the HC, the HC shall pay the HC's receipt of the decision. If the decision is in favor of the HC, the contractor will either:
- 9.1.3.5** clear the amount which is ordered from the HC account; or
- 9.1.3.6** repay to the HC the amount ordered;

Either option shall be completed within 10 days after the contractor's receipt of the arbitrator's decision.

**10.0 24 CFR 85.36(i), Procurement.** Pursuant to this CFR, as issued by the Office of the Secretary, HUD, the HC and the Contractor each agree to comply with the following provisions:

**10.1 Remedies for Contractor Breach:** Pertaining to contract-related issues, it is the responsibility of both the HC and the contractor to communicate with each in as clear and complete a manner as possible. If at any time during the term of this contract the HC or the contractor is not satisfied with any issue, it is the responsibility of that party to deliver to the other party communication, in writing, fully detailing the issue and corrective action (please note that the HC has the right to issue unilateral addendums to this contract, but the contractor does not have the same right). The other party shall, within 10 days, respond in writing to the other party (however, the HC shall retain the right to, if conditions warrant, require the contractor to respond in a shorter period of time). Further, the HC shall, at a minimum, employ the following steps in dealing with the contractor as to any performance issues:

**10.1.1** If the contractor is in material breach of the contract, the HC may terminate the contract for cause. Such termination must be delivered to the contractor in writing and shall fully detail all pertinent issues pertaining to the cause of and justification for the termination.

**10.1.2** Prior to termination, the HC may choose to warn the contractor, verbally or in writing, of any issue of non-compliant or unsatisfactory performance. Such written warning may include placing the contractor on probation, thereby giving the contractor a certain period of time to correct the deficiencies or potentially suffer termination. The HC shall maintain in the contract file a written record of any such warning detailing all pertinent information. If the contractor does not agree with such action, the contractor shall have ten 10 days to dispute or protest, in writing, such action; if he/she does not do so within the 10-day period, he/she shall have no recourse but to accept and agree with the HC's position on the issue. The written protest must detail all pertinent information pertaining to the dispute, including justification detailing the HC's alleged incorrect action(s).

- 10.1.3** After termination, if the contractor does not agree with the HC's justification for the termination, the contractor shall have 10 days to dispute, in writing, such action; if he/she does not do so within the 10-day period, he/she shall have no recourse but to accept and agree with the HC's position on the issue. The written protest must detail all pertinent information pertaining to the dispute, including justification detailing the HC's alleged incorrect action(s).
- 10.1.4** The response to any protest received shall be conducted in accordance with Section No. 4.0 of this document.
- 10.2 Termination For Cause and Convenience:** When the contract amount is more than \$10,000, this contract may be terminated by either party under the terms outlined in the attached **HUD Table 5.1 – Mandatory Contract Clauses for Small Purchases Other Than Construction**, attached hereto.
- 10.3 Executive Order 11246:** For all construction contracts awarded in excess of \$10,000, both parties hereby agree to comply with Executive Order 11246 of September 24, 1965, entitled "Equal Employment Opportunity," as amended by Executive Order 11375 of October 13, 1967, and as supplemented in Department of Labor Regulations (41 CFR Chapter 60).
- 10.4 Copeland "Anti-Kickback" Act:** For all construction or repair contracts awarded, both parties hereby agree to comply with the Copeland "Anti-Kickback" Act (18 U.S.C. 874) as supplemented in Department of Labor Regulations (29 CFR Part 3).
- 10.5 Davis-Bacon-Act:** For all construction contracts awarded in excess of \$2,000 when required by Federal Grant Program legislation, both parties hereby agree to comply with the Davis-Bacon Act (40 U.S.C. 276a to 276a-7) as supplemented in Department of Labor Regulations (29 CFR Part 5).
- 10.6 Sections 103 and 107 of the Contract Work Hours and Safety Standards Act:** For all construction contracts awarded in excess of \$2,000 and for other contracts, which involve the employment of mechanics or laborers awarded in excess of \$2,500, both parties hereby agree to comply with the Sections 103 and 107 of the Contract Work Hours and Safety Act (40 U.S.C. 327-330) as supplemented in Department of Labor Regulations (29 CFR Part 5).
- 10.7 Reporting:** Both parties hereby agree to comply with any reporting requirements that may be detailed herein.
- 10.8 Patent Rights:** Both parties hereby agree to comply with HUD Bulletin 90-23, which is the (a) Notice of Assistance Regarding Patent and Copyright Infringement.
- 10.9 Copy Rights/Rights in Data:** In addition to the requirements contained within **HUD Table 5.1 – Mandatory Contract Clauses for Small Purchases Other Than Construction**, the HC has unlimited rights to any data, including computer software, developed by the contractor in the performance of the contract specifically:
- 10.9.1** Except as provided elsewhere in this clause, the HC shall have unlimited rights in data first produced in the performance of this contract; form, fit, and function data delivered under this contract; data delivered under this contract (except for restricted computer software) that constitute manuals or instructional and training material for installation, operation, or routine maintenance and repair of items, components, or processes delivered or furnished for use under this contract; and all other data delivered under this contract unless provided otherwise for limited rights data or restricted computer software.



- 10.9.2** The contractor shall have the right to: use, release to others, reproduce, distribute, or publish any data first produced or specifically used by the contractor in the performance of this contract, unless provided otherwise in this clause; protect from unauthorized disclosure and use those data which are limited rights data or restricted computer software to the extent provided in this clause; substantiate use of, add or correct limited rights, restricted rights, or copyright notices and to take other appropriate action in accordance with this clause; and establish claim to copyright subsisting in data first produced in the performance of this contract to the extent provided below.
- 10.9.3** For data first produced in the performance of this contract, the contractor may establish, without prior approval of the PM, claim to copyright subsisting in scientific or technical articles based on or containing data first produced in the performance of this contract. The contractor grants the HC and others acting on its behalf a paid-up, non-exclusive, irrevocable, worldwide license in such copyrighted data to reproduce, prepare derivative works, distribute copies to the public, and perform or display publicly by or on behalf of the HC.
- 10.9.4** The contractor shall not, without the prior written permission of the contracting Officer, incorporate in data delivered under this contract any data not first produced in the performance of this contract and which contains copyright notice, unless the contractor identifies such data and grants the HC a license of the same scope as identified in the preceding paragraph.
- 10.9.5** The HC agrees not to remove any copyright notices placed on data and to include such notices in all reproductions of the data. If any data delivered under this contract are improperly marked, the HC may either return the data to the contractor, or cancel or ignore the markings.
- 10.9.6** The contractor is responsible for obtaining from its subcontractors all data and rights necessary to fulfill the contractor's obligations under this contract.
- 10.9.7** Notwithstanding any provisions to the contrary contained in the contractor's standard commercial license or lease contract pertaining to any restricted computer software delivered under this contract, and irrespective of whether any such contract has been proposed prior to the award of this contract or of the fact that such contract may be affixed to or accompany the restricted computer software upon delivery, the contractor agrees the HC shall have the rights set forth below to use, duplicate, or disclose any restricted computer software delivered under this contract. The terms and conditions of this contract, including any commercial lease or licensing contract, shall be subject to the following procedures.
- 10.9.8** The restricted computer software delivered under this contract may not be used, reproduced, or disclosed by the HC except as provided below or as expressly stated otherwise in this contract. The restricted computer software may be: used or copied for use in or with the computer(s) for which it was acquired, including use at any HC location to which such computer(s) may be transferred; used or copied for use in or with backup computer if any computer for which it was acquired is inoperative; reproduced for safekeeping (archives) or backup purposes; modified, adapted, or combined with other computer software, provided that the modified, combined, or adapted portions of the derivative software incorporating any of the delivered, restricted computer software shall

be subject to the same restrictions set forth in this contract; and used or copies for use in or transferred to a replacement computer.

**10.10 Clean Air Act:** For all contracts in excess of \$100,000, both parties hereby agree to comply with all applicable standards, orders or requirements issued under section 306 of the Clean Air Act (42 U.S.C. 1857(h)), Section 508 of the Clean Water Act (33 U.S.C. 1368), Executive Order 11738, and Environmental Protection Agency regulations (40 CFR Part 15).

**10.11 Energy Policy and Conservation Act:** Both parties hereby agree to comply with all mandatory standards and policies relating to energy efficiency, which are contained in the state energy conservation plan issued in compliance with the Energy Policy and Conservation Act (Pub. L. 94-163, 89 Stat. 871).

**11.0 Additional Considerations:**

**11.1 Right of Joinder Pursuant to NRS 332.195:**

**11.1.1** Any political subdivision within the State of Michigan may be granted the privilege of joining the awarded contract, only at the option of the Contractor. If the Contractor so grants such a privilege, the terms and conditions of the RFP documents, including the ensuing contract, may be passed on to the joining political subdivision by the Contractor.

**11.1.2** The Contractor shall retain the unilateral right to allow or disallow any political subdivision the privilege of joining the awarded contract. In the event the Contractor allows another political subdivision to join the HC contract, it is expressly understood that the HC shall in no way be liable for the joining political subdivision obligations to the Contractor in any manner whatsoever.

**11.2 Non-Escalation:** Unless otherwise specified within the RFP documents, the unit prices reflected on the contract shall remain firm with no provision for price increases during the term of the contract.

**11.3 Funding Restrictions and Order Quantities:** The HC reserves the right to reduce or increase estimated or actual quantities in whatever amount necessary without prejudice or liability to the HC, if:

**12.3.1** funding is not available;

**12.3.2** legal restrictions are placed upon the expenditure of monies for this category of service or supplies; or

**12.3.3** the HC's requirements in good faith change after award of the contract.

**11.4** Unless otherwise stated in the RFP documents, all local, State or Federal permits which may be required to provide the services ensuing from award of this RFP, whether or not they are known to either the HC or the proposers at the time of the proposal submittal deadline or the award, shall be the sole responsibility of the Contractor and any costs that were submitted by the Contractor in response to the RFP shall reflect all costs required by the Contractor to procure and provide such necessary permits.

**11.5 Taxes:** All persons doing business with the HC are hereby made aware that the HC is exempt from paying Michigan State Sales and Use Taxes and Federal Excise Taxes. A letter of Tax Exemption will be provided upon request.

- 11.6 Government Standards:** It is the responsibility of the proposer to ensure that all items and services proposed conform to all local, State and Federal law concerning safety (OSHA and NIOSH) and environmental control (EPA and City of Ann Arbor Pollution Regulations) and any other enacted ordinance, code, law or regulation. The Contractor shall be responsible for all costs incurred for compliance with any such possible ordinance, code, law or regulation. No time extensions shall be granted or financial consideration given to the Contractor for time or monies lost due to violations of any such ordinance, code, law or regulations that may occur.
- 11.7 Freight on Bill and Delivery:** All costs submitted by the proposer shall reflect the cost of delivering the proposed items and/or services to the location(s) specified within the RFP documents or within the contract.
- 11.7.1** The Contractor agrees to deliver to the designated location(s) on or before the date as specified in the finalized contract. Failure to deliver on or before the specified date constitutes an event of default by the Contractor. Upon default, the Contractor agrees that the HC may, at its option, rescind the finalized contract under the default clause herein and seek compensatory damages as provided by law.
- 11.8 Backorders:**
- 11.8.1** The HC PM must be notified in writing by the contractor within 10 days of any and all backordered materials and/or any incomplete services; and the estimated delivery date.
- 11.8.2** Unless otherwise stipulated in the contract, any order that will take more than a maximum of 10 days past the original agreed upon delivery date, may at the option of the HC, be canceled and ordered from another source, if, in the opinion of the HC PM, it is in the best interests of the HC to do so.
- 11.9 Work on HC Property:** If the Contractor's work under the contract involves operations by the Contractor on HC premises, the Contractor shall take all necessary precautions to prevent the occurrence of any injury to persons or property during the progress of such work and, except to the extent that any such injury is caused solely and directly by the HC's negligence, shall indemnify the HC, and their officers, agents, servants and employees against all loss which may result in any way from any act or omission of the Contractor, its agents, employees, or subcontractors.
- 11.10 Official, Agent and Employees of the HC Not Personally Liable:** It is agreed by and between the parties hereto that in no event shall any official, officer, employee, or agent of the HC in any way be personally liable or responsible for any covenant or agreement herein contained whether expressed or implied, nor for any statement, representation or warranty made herein or in any connection with this agreement.
- 11.11 Subcontractors:** Unless otherwise stated within the Small Purchase documents, the Contractor may not use any subcontractors to accomplish any portion of the services described within the documents or the contract without the prior written permission of the HC PM.
- 11.12 Salaries and Expenses Relating to the Contractors Employees:** Unless otherwise stated within the procurement documents, the Contractor shall pay all salaries and expenses of, and all Federal, Social Security taxes, Federal and State Unemployment taxes, and any similar taxes relating to its employees used in the performance of the contract. The

Contractor further agrees to comply with all Federal, State and local wage and hour laws and all licensing laws applicable to its employees or other personnel furnished under this agreement.

**11.13 Attorney's Fees:** In the event that litigation is commenced by one party hereto against the other in connection with the enforcement of any provision of this agreement, the prevailing party shall be paid by the losing party all court costs and other expenses of such litigation, including reasonable attorneys' fees. The amount so allowed as attorneys' fees shall be taxed to the losing party as costs of the suit, unless prohibited by law.

**11.14 Independent Contractor:** Unless otherwise stated within the Small Purchase documents or the contract, the Contractor is an independent contractor. Nothing herein shall create any association, agency, partnership or joint venture between the parties hereto and neither shall have any authority to bind the other in any way.

**11.15 Severability:** If any provision of this agreement or any portion or provision hereof applicable to any particular situation or circumstance is held valid, the remainder of this agreement or the remainder of such provision (as the case may be), and the application thereof to other situations or circumstances shall not be affected thereby.

**11.16 Waiver of Breach:** A waiver of either party of any terms or condition of this agreement in any instance shall not be deemed or construed as a waiver of such term or condition for the future, or of any subsequent breach thereof. All remedies, rights, undertakings, obligations, and agreements contained in this agreement shall be cumulative and none of them shall be in limitation of any other remedy, right, obligation or agreement of either party.

**11.17 Time of the Essence:** Time is of the essence under this agreement as to each provision in which time of performance is a factor.

**11.18 Limitation of Liability:** In no event shall the HC be liable to the Contractor for any indirect, incidental, consequential or exemplary damages.

**11.19 Indemnification:**

**11.19.1** The Contractor shall indemnify, defend, and hold the HC (and its officers, employees, and agents) harmless from and against any and all claims, damages, losses, suits, actions, decrees, judgments, attorney's fees, court costs and other expenses of any kind or character, which are caused by, arise out of, or occur due to any failure of the Contractor to (1) abide by any of the applicable professional standards within its industry, or (2) comply with the terms, conditions, or covenants that are contained in this contract, (3) comply with the "Michigan Industrial Insurance Act," or any other law, ordinance, or decree; or (4) ensure that the any subcontractors abide by the terms of this provision and this contract; provided, however, that Contractor will not be required to indemnify the HC against any loss or damage which was specifically caused by the HC providing inaccurate information to the Contractor, failing to provide necessary and requested information to the Contractor, or refusal to abide by any recommendation of the Contractor.

**11.19.2** In this connection, it is expressly agreed that the Contractor shall, at its own expense, defend the HC, its officers, employees, and agents, against any and all claims, suits or actions which may be brought against them, or any of them, as a result of, or by reason of, or arising out of, or on account of, or in consequence of any act or failure to act the consequences of which the Contractor has indemnified the HC. If the Contractor shall fail to do so, the HC shall have the right, but not the obligation, to defend the same and to charge

all direct and incidental costs of such defense to the Contractor including attorney's fees and court costs.

**11.19.3** Any money due to the Contractor under and by virtue of this contract, which the HC believes must be withheld from the Contractor to protect the HC, may be retained by the HC so long as it is reasonably necessary to ensure the HC's protection; or in case no money is due, its surety may be held until all applicable claims have been settled and suitable evidence to that effect furnished to the HC provided, however, neither the Corporation's payments shall not be withheld, and its surety shall be released, if the Contractor is able to demonstrate that it has adequate liability and property damage insurance to protect the HC from any potential claims.

**11.19.4** The Contractor shall provide that any contractual arrangement with a subcontractor shall be in conformance with the terms of this Contract including the terms of this indemnity provision. The Contractor guarantees that it will promptly handle and rectify any and all claims for materials, supplies and labor, or any other claims that may be made against it or any of its subcontractors in connection with the contract.

**11.20 Additional Federally Required Orders/Directives:** Both parties agree that they will comply with the following laws and directives, where applicable.

**12.0 Appendices:**

**12.1** The following noted documents are placed under each of the noted appendix and are a part of this contract:

**12.1.2 Appendix No. 1: Federal Davis-Bacon Wage Rate applicable to this Contract**

**12.1.3 Appendix No. 2: Contractor Certification of Asbestos Free Product Installation**

**12.1.4 Appendix No. 3: Disclosure of Asbestos**

**12.1.5 Appendix No. 4: Lien Waiver Form**

**12.1.6 Appendix No. 5: Subcontractor Sworn Statement**

**12.2** Please note that, in the case of any discrepancy between this contract and any of the above noted documents, the requirement(s) listed within the body of this contract shall first take precedence, then the requirement(s) listed within each appendix shall take precedence in the order they are listed above (i.e. the requirement(s) listed the lower listed item may not overrule any requirement(s) within a higher listed item).

**12.3** Any document referenced herein that has not been attached is hereby incorporated herein by reference, and a copy of each such document is available from the HC upon written request for such.

**13.0 CERTIFICATIONS:**

The undersigned representatives of each party acknowledge by signature below that they have reviewed the foregoing and understand and agree to abide by their respective obligations as defined herein:

**By:** \_\_\_\_\_  
**CONTRACTOR**

**Date:**

**By:** \_\_\_\_\_ **Date:**

**Jennifer Hall, Executive Director  
Ann Arbor Housing Commission  
727 Miller Avenue  
Ann Arbor, MI 48103  
734-994-2831**

# Appendix No. 1

## Davis Bacon Wage Rate

General Decision Number: MI150024 07/24/2015 MI24

Superseded General Decision Number: MI20140024

State: Michigan

Construction Type: Residential

County: Washtenaw County in Michigan.

RESIDENTIAL CONSTRUCTION PROJECTS (consisting of single family homes and apartments up to and including 4 stories).

Note: Executive Order (EO) 13658 establishes an hourly minimum wage of \$10.10 for 2015 that applies to all contracts subject to the Davis-Bacon Act for which the solicitation is issued on or after January 1, 2015. If this contract is covered by the EO, the contractor must pay all workers in any classification listed on this wage determination at least \$10.10 (or the applicable wage rate listed on this wage determination, if it is higher) for all hours spent performing on the contract. The EO minimum wage rate will be adjusted annually. Additional information on contractor requirements and worker protections under the EO is available at [www.dol.gov/whd/govcontracts](http://www.dol.gov/whd/govcontracts).

Modification Number	Publication Date
0	01/02/2015
1	04/03/2015
2	06/26/2015
3	07/03/2015
4	07/10/2015
5	07/24/2015

ASBE0025-005 06/01/2015

Townships of Ann Arbor, Augusta, Lodi, Northfield, Pittsfield, Salem, Saline, Scio, Superior, Webster, Ypsilanti & York

**APPENDIX: 2**

**Form D-4**

**Contractor Certification of Asbestos-Free  
Product Installation**

Name of building: \_\_\_\_\_

1. Contractor name and address:

\_\_\_\_\_  
Name

\_\_\_\_\_  
Street

\_\_\_\_\_  
City

\_\_\_\_\_  
State

\_\_\_\_\_  
Zip

2. Brief scope of contracted activities:

\_\_\_\_\_  
\_\_\_\_\_  
\_\_\_\_\_

3. Certification statement:

I \_\_\_\_\_, representing and having authority for \_\_\_\_\_  
(company), hereby certify that any and all products/materials which will be and/or have been installed or introduced into  
the above-mentioned building, \_\_\_\_\_ (project name and/or number) are asbestos free (or  
less than 1% asbestos by weight).

\_\_\_\_\_  
Print Name

\_\_\_\_\_  
Signature

\_\_\_\_\_  
Company

\_\_\_\_\_  
Position

\_\_\_\_\_  
Date



**APPENDIX: 3**

Form D-3

**Employer/Employee/Tenant Notification**

As required by the OSHA Regulation building and/or facility owners shall notify the following persons of the presence, location and quantity of ACM or PACM, at the work sites in their buildings and facilities. Notification either shall be in writing or shall consist of a personal communication between the owner and the person to whom notification must be given or their authorized representative:

- A. Prospective employers applying or bidding for work whose employees reasonably can be expected to work in adjacent to areas containing such material;
- B. Employees of the owner who will work in or adjacent to areas containing such materials;
- C. On Multi-employer worksites, all employers of employees who will be performing work within or adjacent to areas containing such material;
- D. Tenants who will occupy areas containing such materials.

Please complete this form and return it to: Ann Arbor Housing Commission

I \_\_\_\_\_, representing and having authority for \_\_\_\_\_(company),

hereby indicate and agree that a representative of the Ann Arbor Housing Commission building/facility, Lance Mitchell has provided me information regarding the specific locations and materials that are asbestos-containing and which may be encountered or have the potential of being encountered during the course of activities involving renovation of 805 – 807 W. Washington in the above-mentioned building.

I expressly agree that neither I, nor any of my employees, agents, sub-contractors or other individuals or entities over whom I have any responsibility or control, will disturb asbestos-containing materials for the above mentioned building. I further understand and agree that should I, my employees, agents, sub-contractors or other individuals or entities over whom I have control, encounter any material(s) suspected of containing asbestos, said material(s) shall not be disturbed without first notifying the office of the building/facility owner, and receiving written approval that such material(s) may be disturbed.

\_\_\_\_\_  
 Print Name

\_\_\_\_\_  
 Signature

\_\_\_\_\_  
 Company

\_\_\_\_\_  
 Position

\_\_\_\_\_  
 Date

## Asbestos Containing Materials by Property

<b>Buildings that have been sampled for asbestos</b>	
<b>Building</b>	<b>Identified or Presumed Asbestos Containing Building Material</b>
Miller Manor	Drywall Systems, floor tile/mastic, sink undercoating, exterior cement caulk, ceiling tile and presumed roofing materials
Maple Meadows	Drywall Systems, heat shield, floor tile and presumed roofing materials
Hikone	Drywall Systems, heat shield, floor tile/underlayment and presumed roofing materials
Green Baxter	Drywall Systems, heat shield, floor tile and presumed roofing materials
Baker Commons	Sink undercoating
Oakwood	Drywall Systems in 3565 and 3575 only and presumed roofing material
Mallets Creek	Presumed in roofing material
Hillside Manor	Presumed in roofing material
3681 -3689 Platt	Presumed in roofing material
Seventh	Presumed in roofing material
Broadway	Presumed in roofing material
White/State/Henry	Building 701 rear exterior window caulk, rear speak panel board exterior calk all buildings, presumed roofing material
3451 – 3457 Platt	Drywall systems, unit 3451 flooring, presumed roofing
W. Washington	Presumed in roofing material
Evelyn	Presumed in roofing material
North Maple Estates	Drywall systems in unit 725, 731, and 735 and presumed roofing material

TEST RESULTS are posted at [www.a2.gov/housingcommission](http://www.a2.gov/housingcommission)

**APPENDIX: 4**

**Waiver of Lien**

My/our contract with: \_\_\_\_\_ to  
provide \_\_\_\_\_ for the improvement  
to: \_\_\_\_\_

**(Check One)**

**Partial Conditional**

I hereby waive my/our construction lien to the amount \$ \_\_\_\_\_ for  
labor/materials provided. This waiver, together with all previous waivers, if any, does not cover amounts  
due to me/us for the contract improvement provided.

This waiver is conditioned on actual payment of \$ \_\_\_\_\_.

**Partial Unconditional**

Having been fully paid and satisfied, hereby waive my/our construction lien to the  
amount of \$ \_\_\_\_\_ for the labor/materials provided through \_\_\_\_\_. This  
waiver, together with all previous waivers, if any, does/does not cover all amounts due to me/us for  
contract improvement provided through the date shown above.

**Full Conditional**

Having been fully paid and satisfied, all my/our construction lien rights against such property  
are hereby waived and released.

This waiver is conditioned on the actual payment of \$ \_\_\_\_\_.

**Full Unconditional**

Having been fully paid and satisfied, all my/our construction lien rights against such property  
are hereby waived and released.

Date: \_\_\_\_\_

Signature: \_\_\_\_\_

Company: \_\_\_\_\_

Address: \_\_\_\_\_

Phone: \_\_\_\_\_

**DO NOT SIGN BLANK FORM**

**APPENDIX: 5**

**SWORN STATEMENT**

State of Michigan

} §

County of Washtenaw

\_\_\_\_\_, being duly sworn, states the following:

is the (contractor)(subcontractor) for an improvement to the following real property in Washtenaw County, Michigan, described as follows: \_\_\_\_\_

The following is a statement of each subcontractor, supplier and laborer, for whom payment of wages or fringe benefits and withholdings is due but unpaid, with whom the **(contractor)(subcontractor)** has (contracted)(subcontracted) for performance under the contract with the owner or lessee, and the amounts due to the persons as of the date of this statement are correctly and fully set forth opposite their names:

Name, Address & Phone Number of Subcontractor, Supplier, or Laborer	Type of Improvement Furnished	Total Contract Price	Amount Already Paid	Amount Currently Owing	Balance to Complete (optional)	Amount of Laborer Wages Due but Unpaid	Amount of Fringe Benefits and Withholdings Due But Unpaid
Totals							

(Some columns may not be applicable to all persons listed)

The contractor has not procured material from, or subcontracted with, any person other than those set forth and owes no money for the improvement other than the sums set forth.\*

I make this statement as the (contractor)(subcontractor) or as of the (contractor)(sub-contractor) to represent to the owner or lessee of the property and his or her agents that the property is free from claims of construction liens, or the possibility of construction liens, except as specifically set forth in this statement and except for claims of construction liens by laborers that may be provided under Section 109 of the Construction Lien Act, 1980 PA 497, MCL 570.1 109.

**WARNING TO OWNER OR LESSEE: AN OWNER OR LESSEE OF THE PROPERTY MAY NOT RELY ON THIS SWORN STATEMENT TO AVOID THE CLAIM OF A SUBCONTRACTOR, SUPPLIER OR LABORER WHO HAS PROVIDED A NOTICE OF FURNISHING OR A LABORER WHO MAY PROVIDE A NOTICE OF FURNISHING UNDER SECTION 109 OF THE CONSTRUCTION LIEN ACT, 1980 PA 497, MCL 570.1109 TO THE DESIGNEE OR TO THE OWNER OR LESSEE IF THE DESIGNEE IS NOT NAMED OR HAS DIED.**

**IF THIS SWORN STATEMENT IS IN REGARD TO A RESIDENTIAL STRUCTURE, ON RECEIPT OF THIS SWORN STATEMENT, THE OWNER OR LESSEE, OR THE OWNER'S OR LESSEE'S DESIGNEE MUST GIVE NOTICE OF ITS RECEIPT, EITHER IN WRITING, OR BY TELEPHONE, OR PERSONALLY. TO EACH SUBCONTRACTOR, SUPPLIER, AND LABORER WHO HAS PROVIDED A NOTICE OF FURNISHING UNDER SECTION 109 OR, IF A NOTICE OF FURNISHING IS EXCUSED UNDER SECTION 108 OR 108A, TO EACH SUBCONTRACTOR, SUPPLIER, AND LABORER NAMED IN THE SWORN STATEMENT. IF A SUBCONTRACTOR, SUPPLIER WHO HAS PROVIDED LESSEE, OR DESIGNEE SHALL PROVIDE THE REQUESTER A COPY OF THE SWORN STATEMENT WITHIN 10 BUSINESS DAYS AFTER RECEIVING THE REQUEST.**

\_\_\_\_\_  
Despondent Printed Name

\_\_\_\_\_  
Despondent Signature

**WARNING TO DESPONDENT: A PERSON WHO GIVES A FALSE SWORN STATEMENT WITH INTENT TO DEFRAUD IS SUBJECT TO CRIMINAL PENALTIES AS PROVIDED IN SECTION 110 OF THE CONSTRUCTION LIEN ACT, 1980 PA 497, MCL 570.1110.**

Subscribed and sworn to before me this  
\_\_\_\_\_ day of \_\_\_\_\_, \_\_\_\_\_

\_\_\_\_\_

Notary Public, \_\_\_\_\_ County, Michigan

My Commission Expires:

\_\_\_\_\_

\*Materials furnished by a contractor or a subcontractor out of his or her own inventory, and which has not been purchased specifically for the purpose of performing the contract, need not be listed.

**PERFORMANCE BOND**

(1) \_\_\_\_\_ of \_\_\_\_\_ (referred to as "Principal"), and \_\_\_\_\_, a corporation duly authorized to do business in the State of Michigan (referred to as "Surety"), are bound to the City of Ann Arbor, Michigan (referred to as "City"), for

\$ \_\_\_\_\_, the payment of which Principal and Surety bind themselves, their heirs, executors, administrators, successors and assigns, jointly and severally, by this bond.

(2) The Principal has entered a written Contract with the City dated \_\_\_\_\_, 201\_, for: \_\_\_\_\_ and this bond is given for that Contract in compliance with Act No. 213 of the Michigan Public Acts of 1963, as amended, being MCL 129.201 et seq.

(3) Whenever the Principal is declared by the City to be in default under the Contract, the Surety may promptly remedy the default or shall promptly:

(a) complete the Contract in accordance with its terms and conditions; or

(b) obtain a bid or bids for submission to the City for completing the Contract in accordance with its terms and conditions, and upon determination by Surety of the lowest responsible bidder, arrange for a Contract between such bidder and the City, and make available, as work progresses, sufficient funds to pay the cost of completion less the balance of the Contract price; but not exceeding, including other costs and damages for which Surety may be liable hereunder, the amount set forth in paragraph 1.

(4) Surety shall have no obligation to the City if the Principal fully and promptly performs under the Contract.

(5) Surety agrees that no change, extension of time, alteration or addition to the terms of the Contract or to the work to be performed thereunder, or the specifications accompanying it shall in any way affect its obligations on this bond, and waives notice of any such change, extension of time, alteration or addition to the terms of the Contract or to the work, or to the specifications.

**SIGNED AND SEALED** this \_\_\_\_\_ day of \_\_\_\_\_, 201\_.

\_\_\_\_\_  
(Name of Surety Company)

By \_\_\_\_\_  
(Signature)

Its \_\_\_\_\_  
(Title of Office)

\_\_\_\_\_  
(Name of Principal)

By \_\_\_\_\_  
(Signature)

Its \_\_\_\_\_  
(Title of Office)

Approved as to form:

\_\_\_\_\_  
Stephen K. Postema, City Attorney

Name and address of agent:

\_\_\_\_\_  
\_\_\_\_\_  
\_\_\_\_\_

## LABOR AND MATERIAL BOND

- (1) \_\_\_\_\_  
of \_\_\_\_\_ (referred to as "Principal"), and \_\_\_\_\_, a corporation duly authorized to do business in the State of Michigan, (referred to as "Surety"), are bound to the City of Ann Arbor, Michigan (referred to as "City"), for the use and benefit of claimants as defined in Act 213 of Michigan Public Acts of 1963, as amended, being MCL 129.201 et seq., in the amount of \$ \_\_\_\_\_, for the payment of which Principal and Surety bind themselves, their heirs, executors, administrators, successors and assigns, jointly and severally, by this bond.
- (2) The Principal has entered a written Contract with the City, dated \_\_\_\_\_, 201\_, for \_\_\_\_\_; and this bond is given for that Contract in compliance with Act No. 213 of the Michigan Public Acts of 1963 as amended;
- (3) If the Principal fails to promptly and fully repay claimants for labor and material reasonably required under the Contract, the Surety shall pay those claimants.
- (4) Surety's obligations shall not exceed the amount stated in paragraph 1, and Surety shall have no obligation if the Principal promptly and fully pays the claimants.

**SIGNED AND SEALED** this \_\_\_\_\_ day of \_\_\_\_\_, 201\_

\_\_\_\_\_  
(Name of Surety Company)

By \_\_\_\_\_  
(Signature)

Its \_\_\_\_\_  
(Title of Office)

Approved as to form:

\_\_\_\_\_  
Stephen K. Postema, City Attorney

\_\_\_\_\_  
(Name of Principal)

By \_\_\_\_\_  
(Signature)

Its \_\_\_\_\_  
(Title of Office)

Name and address of agent:

\_\_\_\_\_  
\_\_\_\_\_  
\_\_\_\_\_

# **GENERAL CONDITIONS**

## **Section 1 - Execution, Correlation and Intent of Documents**

The contract documents shall be signed in 2 copies by the City and the Contractor.

The contract documents are complementary and what is called for by any one shall be binding. The intention of the documents is to include all labor and materials, equipment and transportation necessary for the proper execution of the work. Materials or work described in words which so applied have a well-known technical or trade meaning have the meaning of those recognized standards.

In case of a conflict among the contract documents listed below in any requirement(s), the requirement(s) of the document listed first shall prevail over any conflicting requirement(s) of a document listed later.

(1) Addenda in reverse chronological order; (2) Detailed Specifications; (3) Standard Specifications; (4) Plans; (5) General Conditions; (6) Contract; (7) Bid Forms; (8) Bond Forms; (9) Bid.

## **Section 2 - Order of Completion**

The Contractor shall submit with each invoice, and at other times reasonably requested by the Supervising Professional, schedules showing the order in which the Contractor proposes to carry on the work. They shall include the dates at which the Contractor will start the several parts of the work, the estimated dates of completion of the several parts, and important milestones within the several parts.

## **Section 3 - Familiarity with Work**

The Bidder or its representative shall make personal investigations of the site of the work and of existing structures and shall determine to its own satisfaction the conditions to be encountered, the nature of the ground, the difficulties involved, and all other factors affecting the work proposed under this Contract. The Bidder to whom this Contract is awarded will not be entitled to any additional compensation unless conditions are clearly different from those which could reasonably have been anticipated by a person making diligent and thorough investigation of the site.

The Bidder shall immediately notify the City upon discovery, and in every case prior to submitting its Bid, of every error or omission in the bidding documents that would be identified by a reasonably competent, diligent Bidder. In no case will a Bidder be allowed the benefit of extra compensation or time to complete the work under this Contract for extra expenses or time spent as a result of the error or omission.

## **Section 4 - Wage Requirements**

Under this Contract, the Contractor shall conform to Chapter 14 of Title I of the Code of the City of Ann Arbor as amended; which in part states "...that all craftsmen, mechanics and laborers employed directly on the site in connection with said improvements, including said employees of subcontractors, shall receive the prevailing wage for the corresponding classes of craftsmen,



mechanics and laborers, as determined by statistics for the Ann Arbor area compiled by the United States Department of Labor. At the request of the City, any contractor or subcontractor shall provide satisfactory proof of compliance with the contract provisions required by the Section."

Where the Contract and the Ann Arbor City Ordinance are silent as to definitions of terms required in determining contract compliance with regard to prevailing wages, the definitions provided in the Davis-Bacon Act as amended (40 U.S.C. 278-a to 276-a-7) for the terms shall be used.

If the Contractor is a "covered employer" as defined in Chapter 23 of the Ann Arbor City Code, the Contractor agrees to comply with the living wage provisions of Chapter 23 of the Ann Arbor City Code. The Contractor agrees to pay those employees providing Services to the City under this Agreement a "living wage," as defined in Section 1:815 of the Ann Arbor City Code, as adjusted in accordance with Section 1:815(3); to post a notice approved by the City of the applicability of Chapter 23 in every location in which regular or contract employees providing services under this Agreement are working; to maintain records of compliance; if requested by the City, to provide documentation to verify compliance; to take no action that would reduce the compensation, wages, fringe benefits, or leave available to any employee or person contracted for employment in order to pay the living wage required by Section 1:815; and otherwise to comply with the requirements of Chapter 23.

Contractor agrees that all subcontracts entered into by the Contractor shall contain similar wage provision covering subcontractor's employees who perform work on this contract.

## **Section 5 - Non-Discrimination**

The Contractor agrees to comply, and to require its subcontractor(s) to comply, with the nondiscrimination provisions of MCL 37.2209. The Contractor further agrees to comply with the provisions of Section 9:158 of Chapter 112 of Title IX of the Ann Arbor City Code, and to assure that applicants are employed and that employees are treated during employment in a manner which provides equal employment opportunity.

## **Section 6 - Materials, Appliances, Employees**

Unless otherwise stipulated, the Contractor shall provide and pay for all materials, labor, water, tools, equipment, light, power, transportation, and other facilities necessary or used for the execution and completion of the work. Unless otherwise specified, all materials incorporated in the permanent work shall be new, and both workmanship and materials shall be of the highest quality. The Contractor shall, if required, furnish satisfactory evidence as to the kind and quality of materials.

The Contractor shall at all times enforce strict discipline and good order among its employees, and shall seek to avoid employing on the work any unfit person or anyone not skilled in the work assigned.

Adequate sanitary facilities shall be provided by the Contractor.

## **Section 7 - Qualifications for Employment**

The Contractor shall employ competent laborers and mechanics for the work under this Contract. For work performed under this Contract, employment preference shall be given to qualified local residents.

## **Section 8 - Royalties and Patents**

The Contractor shall pay all royalties and license fees. It shall defend all suits or claims for infringements of any patent rights and shall hold the City harmless from loss on account of infringement except that the City shall be responsible for all infringement loss when a particular process or the product of a particular manufacturer or manufacturers is specified, unless the City has notified the Contractor prior to the signing of the Contract that the particular process or product is patented or is believed to be patented.

## **Section 9 - Permits and Regulations**

The Contractor must secure and pay for all permits, permit or plan review fees and licenses necessary for the prosecution of the work. These include but are not limited to City building permits, right-of-way permits, lane closure permits, right-of-way occupancy permits, and the like. The City shall secure and pay for easements shown on the plans unless otherwise specified.

The Contractor shall give all notices and comply with all laws, ordinances, rules and regulations bearing on the conduct of the work as drawn and specified. If the Contractor observes that the contract documents are at variance with those requirements, it shall promptly notify the Supervising Professional in writing, and any necessary changes shall be adjusted as provided in the Contract for changes in the work.

## **Section 10 - Protection of the Public and of Work and Property**

The Contractor is responsible for the means, methods, sequences, techniques and procedures of construction and safety programs associated with the work contemplated by this contract. The Contractor, its agents or sub-contractors, shall comply with the "General Rules and Regulations for the Construction Industry" as published by the Construction Safety Commission of the State of Michigan and to all other local, State and National laws, ordinances, rules and regulations pertaining to safety of persons and property.

The Contractor shall take all necessary and reasonable precautions to protect the safety of the public. It shall continuously maintain adequate protection of all work from damage, and shall take all necessary and reasonable precautions to adequately protect all public and private property from injury or loss arising in connection with this Contract. It shall make good any damage, injury or loss to its work and to public and private property resulting from lack of reasonable protective precautions, except as may be due to errors in the contract documents, or caused by agents or employees of the City. The Contractor shall obtain and maintain sufficient insurance to cover damage to any City property at the site by any cause.

In an emergency affecting the safety of life, or the work, or of adjoining property, the Contractor is, without special instructions or authorization from the Supervising Professional, permitted to act at its discretion to prevent the threatened loss or injury. It shall also so act, without appeal, if authorized or instructed by the Supervising Professional.

Any compensation claimed by the Contractor for emergency work shall be determined by agreement or in accordance with the terms of Claims for Extra Cost - Section 15.

## **Section 11 - Inspection of Work**

The City shall provide sufficient competent personnel for the inspection of the work.

The Supervising Professional shall at all times have access to the work whenever it is in preparation or progress, and the Contractor shall provide proper facilities for access and for inspection.

If the specifications, the Supervising Professional's instructions, laws, ordinances, or any public authority require any work to be specially tested or approved, the Contractor shall give the Supervising Professional timely notice of its readiness for inspection, and if the inspection is by an authority other than the Supervising Professional, of the date fixed for the inspection. Inspections by the Supervising Professional shall be made promptly, and where practicable at the source of supply. If any work should be covered up without approval or consent of the Supervising Professional, it must, if required by the Supervising Professional, be uncovered for examination and properly restored at the Contractor's expense.

Re-examination of any work may be ordered by the Supervising Professional, and, if so ordered, the work must be uncovered by the Contractor. If the work is found to be in accordance with the contract documents, the City shall pay the cost of re-examination and replacement. If the work is not in accordance with the contract documents, the Contractor shall pay the cost.

## **Section 12 - Superintendence**

The Contractor shall keep on the work site, during its progress, a competent superintendent and any necessary assistants, all satisfactory to the Supervising Professional. The superintendent will be responsible to perform all on-site project management for the Contractor. The superintendent shall be experienced in the work required for this Contract. The superintendent shall represent the Contractor and all direction given to the superintendent shall be binding as if given to the Contractor. Important directions shall immediately be confirmed in writing to the Contractor. Other directions will be confirmed on written request. The Contractor shall give efficient superintendence to the work, using its best skill and attention.

## **Section 13 - Changes in the Work**

The City may make changes to the quantities of work within the general scope of the Contract at any time by a written order and without notice to the sureties. If the changes add to or deduct from the extent of the work, the Contract Sum shall be adjusted accordingly. All the changes shall be executed under the conditions of the original Contract except that any claim for extension of time caused by the change shall be adjusted at the time of ordering the change.

In giving instructions, the Supervising Professional shall have authority to make minor changes in the work not involving extra cost and not inconsistent with the purposes of the work, but otherwise, except in an emergency endangering life or property, no extra work or change shall be made unless in pursuance of a written order by the Supervising Professional, and no claim for an addition to the Contract Sum shall be valid unless the additional work was ordered in writing.

The Contractor shall proceed with the work as changed and the value of the work shall be determined as provided in Claims for Extra Cost - Section 15.

## **Section 14 - Extension of Time**

Extension of time stipulated in the Contract for completion of the work will be made if and as the Supervising Professional may deem proper under any of the following circumstances:

- (1) When work under an extra work order is added to the work under this Contract;
- (2) When the work is suspended as provided in Section 20;
- (3) When the work of the Contractor is delayed on account of conditions which could not have been foreseen, or which were beyond the control of the Contractor, and which

were not the result of its fault or negligence;

- (4) Delays in the progress of the work caused by any act or neglect of the City or of its employees or by other Contractors employed by the City;
- (5) Delay due to an act of Government;
- (6) Delay by the Supervising Professional in the furnishing of plans and necessary information;
- (7) Other cause which in the opinion of the Supervising Professional entitles the Contractor to an extension of time.

The Contractor shall notify the Supervising Professional within 7 days of an occurrence or conditions which, in the Contractor's opinion, entitle it to an extension of time. The notice shall be in writing and submitted in ample time to permit full investigation and evaluation of the Contractor's claim. The Supervising Professional shall acknowledge receipt of the Contractor's notice within 7 days of its receipt. Failure to timely provide the written notice shall constitute a waiver by the Contractor of any claim.

In situations where an extension of time in contract completion is appropriate under this or any other section of the contract, the Contractor understands and agrees that the only available adjustment for events that cause any delays in contract completion shall be extension of the required time for contract completion and that there shall be no adjustments in the money due the Contractor on account of the delay.

## **Section 15 - Claims for Extra Cost**

If the Contractor claims that any instructions by drawings or other media issued after the date of the Contract involved extra cost under this Contract, it shall give the Supervising Professional written notice within 7 days after the receipt of the instructions, and in any event before proceeding to execute the work, except in emergency endangering life or property. The procedure shall then be as provided for Changes in the Work-Section 13. No claim shall be valid unless so made.

If the Supervising Professional orders, in writing, the performance of any work not covered by the contract documents, and for which no item of work is provided in the Contract, and for which no unit price or lump sum basis can be agreed upon, then the extra work shall be done on a Cost-Plus-Percentage basis of payment as follows:

- (1) The Contractor shall be reimbursed for all reasonable costs incurred in doing the work, and shall receive an additional payment of 15% of all the reasonable costs to cover both its indirect overhead costs and profit;
- (2) The term "Cost" shall cover all payroll charges for employees and supervision required under the specific order, together with all worker's compensation, Social Security, pension and retirement allowances and social insurance, or other regular payroll charges on same; the cost of all material and supplies required of either temporary or permanent character; rental of all power-driven equipment at agreed upon rates, together with cost of fuel and supply charges for the equipment; and any costs incurred by the Contractor as a direct result of executing the order, if approved by the Supervising Professional;
- (3) If the extra is performed under subcontract, the subcontractor shall be allowed to compute its charges as described above. The Contractor shall be permitted to add an additional charge of 5% percent to that of the subcontractor for the Contractor's

supervision and contractual responsibility;

- (4) The quantities and items of work done each day shall be submitted to the Supervising Professional in a satisfactory form on the succeeding day, and shall be approved by the Supervising Professional and the Contractor or adjusted at once;
- (5) Payments of all charges for work under this Section in any one month shall be made along with normal progress payments. Retainage shall be in accordance with Progress Payments-Section 16.

No additional compensation will be provided for additional equipment, materials, personnel, overtime or special charges required to perform the work within the time requirements of the Contract.

When extra work is required and no suitable price for machinery and equipment can be determined in accordance with this Section, the hourly rate paid shall be 1/40 of the basic weekly rate listed in the Rental Rate Blue Book published by Dataquest Incorporated and applicable to the time period the equipment was first used for the extra work. The hourly rate will be deemed to include all costs of operation such as bucket or blade, fuel, maintenance, "regional factors", insurance, taxes, and the like, but not the costs of the operator.

## **Section 16 - Progress Payments**

The Contractor shall submit each month, or at longer intervals, if it so desires, an invoice covering work performed for which it believes payment, under the Contract terms, is due. The submission shall be to the City's Finance Department - Accounting Division. The Supervising Professional will, within 10 days following submission of the invoice, prepare a certificate for payment for the work in an amount to be determined by the Supervising Professional as fairly representing the acceptable work performed during the period covered by the Contractor's invoice. To insure the proper performance of this Contract, the City will retain a percentage of the estimate in accordance with Act 524, Public Acts of 1980. The City will then, following the receipt of the Supervising Professional's Certificate, make payment to the Contractor as soon as feasible, which is anticipated will be within 15 days.

An allowance may be made in progress payments if substantial quantities of permanent material have been delivered to the site but not incorporated in the completed work if the Contractor, in the opinion of the Supervising Professional, is diligently pursuing the work under this Contract. Such materials shall be properly stored and adequately protected. Allowance in the estimate shall be at the invoice price value of the items. Notwithstanding any payment of any allowance, all risk of loss due to vandalism or any damages to the stored materials remains with the Contractor.

In the case of Contracts which include only the Furnishing and Delivering of Equipment, the payments shall be; 60% of the Contract Sum upon the delivery of all equipment to be furnished, or in the case of delivery of a usable portion of the equipment in advance of the total equipment delivery, 60% of the estimated value of the portion of the equipment may be paid upon its delivery in advance of the time of the remainder of the equipment to be furnished; 30% of the Contract Sum upon completion of erection of all equipment furnished, but not later than 60 days after the date of delivery of all of the equipment to be furnished; and payment of the final 10% on final completion of erection, testing and acceptance of all the equipment to be furnished; but not later than 180 days after the date of delivery of all of the equipment to be furnished, unless testing has been completed and shows the equipment to be unacceptable.

With each invoice for periodic payment, the Contractor shall enclose a Contractor's Declaration - Section 43, and an updated project schedule per Order of Completion - Section 2.

## **Section 17 - Deductions for Uncorrected Work**

If the Supervising Professional decides it is inexpedient to correct work that has been damaged or that was not done in accordance with the Contract, an equitable deduction from the Contract price shall be made.

## **Section 18 - Correction of Work Before Final Payment**

The Contractor shall promptly remove from the premises all materials condemned by the Supervising Professional as failing to meet Contract requirements, whether incorporated in the work or not, and the Contractor shall promptly replace and re-execute the work in accordance with the Contract and without expense to the City and shall bear the expense of making good all work of other contractors destroyed or damaged by the removal or replacement.

If the Contractor does not remove the condemned work and materials within 10 days after written notice, the City may remove them and, if the removed material has value, may store the material at the expense of the Contractor. If the Contractor does not pay the expense of the removal within 10 days thereafter, the City may, upon 10 days written notice, sell the removed materials at auction or private sale and shall pay to the Contractor the net proceeds, after deducting all costs and expenses that should have been borne by the Contractor. If the removed material has no value, the Contractor must pay the City the expenses for disposal within 10 days of invoice for the disposal costs.

The inspection or lack of inspection of any material or work pertaining to this Contract shall not relieve the Contractor of its obligation to fulfill this Contract and defective work shall be made good. Unsuitable materials may be rejected by the Supervising Professional notwithstanding that the work and materials have been previously overlooked by the Supervising Professional and accepted or estimated for payment or paid for. If the work or any part shall be found defective at any time before the final acceptance of the whole work, the Contractor shall forthwith make good the defect in a manner satisfactory to the Supervising Professional. The judgment and the decision of the Supervising Professional as to whether the materials supplied and the work done under this Contract comply with the requirements of the Contract shall be conclusive and final.

## **Section 19 - Acceptance and Final Payment**

Upon receipt of written notice that the work is ready for final inspection and acceptance, the Supervising Professional will promptly make the inspection. When the Supervising Professional finds the work acceptable under the Contract and the Contract fully performed, the Supervising Professional will promptly sign and issue a final certificate stating that the work required by this Contract has been completed and is accepted by the City under the terms and conditions of the Contract. The entire balance found to be due the Contractor, including the retained percentage, shall be paid to the Contractor by the City within 30 days after the date of the final certificate.

Before issuance of final certificates, the Contractor shall file with the City:

- (1) The consent of the surety to payment of the final estimate;
- (2) The Contractor's Affidavit in the form required by Section 44.

In case the Affidavit or consent is not furnished, the City may retain out of any amount due the Contractor, sums sufficient to cover all lienable claims.

The making and acceptance of the final payment shall constitute a waiver of all claims by the City except those arising from:

- (1) unsettled liens;

- (2) faulty work appearing within 12 months after final payment;
- (3) hidden defects in meeting the requirements of the plans and specifications;
- (4) manufacturer's guarantees.

It shall also constitute a waiver of all claims by the Contractor, except those previously made and still unsettled.

## **Section 20 - Suspension of Work**

The City may at any time suspend the work, or any part by giving 5 days notice to the Contractor in writing. The work shall be resumed by the Contractor within 10 days after the date fixed in the written notice from the City to the Contractor to do so. The City shall reimburse the Contractor for expense incurred by the Contractor in connection with the work under this Contract as a result of the suspension.

If the work, or any part, shall be stopped by the notice in writing, and if the City does not give notice in writing to the Contractor to resume work at a date within 90 days of the date fixed in the written notice to suspend, then the Contractor may abandon that portion of the work suspended and will be entitled to the estimates and payments for all work done on the portions abandoned, if any, plus 10% of the value of the work abandoned, to compensate for loss of overhead, plant expense, and anticipated profit.

## **Section 21 - Delays and the City's Right to Terminate Contract**

If the Contractor refuses or fails to prosecute the work, or any separate part of it, with the diligence required to insure completion, ready for operation, within the allowable number of consecutive calendar days specified plus extensions, or fails to complete the work within the required time, the City may, by written notice to the Contractor, terminate its right to proceed with the work or any part of the work as to which there has been delay. After providing the notice the City may take over the work and prosecute it to completion, by contract or otherwise, and the Contractor and its sureties shall be liable to the City for any excess cost to the City. If the Contractor's right to proceed is terminated, the City may take possession of and utilize in completing the work, any materials, appliances and plant as may be on the site of the work and useful for completing the work. The right of the Contractor to proceed shall not be terminated or the Contractor charged with liquidated damages where an extension of time is granted under Extension of Time - Section 14.

If the Contractor is adjudged a bankrupt, or if it makes a general assignment for the benefit of creditors, or if a receiver is appointed on account of its insolvency, or if it persistently or repeatedly refuses or fails except in cases for which extension of time is provided, to supply enough properly skilled workers or proper materials, or if it fails to make prompt payments to subcontractors or for material or labor, or persistently disregards laws, ordinances or the instructions of the Supervising Professional, or otherwise is guilty of a substantial violation of any provision of the Contract, then the City, upon the certificate of the Supervising Professional that sufficient cause exists to justify such action, may, without prejudice to any other right or remedy and after giving the Contractor 3 days written notice, terminate this Contract. The City may then take possession of the premises and of all materials, tools and appliances thereon and without prejudice to any other remedy it may have, make good the deficiencies or finish the work by whatever method it may deem expedient, and deduct the cost from the payment due the Contractor. The Contractor shall not be entitled to receive any further payment until the work is finished. If the expense of finishing the work, including compensation for additional managerial and administrative services exceeds the unpaid balance of the Contract Sum, the Contractor and its surety are liable to the City for any excess cost incurred. The expense incurred by the City, and the damage incurred through the Contractor's default, shall be certified by the Supervising Professional.

## **Section 22 - Contractor's Right to Terminate Contract**

If the work should be stopped under an order of any court, or other public authority, for a period of 3 months, through no act or fault of the Contractor or of anyone employed by it, then the Contractor may, upon 7 days written notice to the City, terminate this Contract and recover from the City payment for all acceptable work executed plus reasonable profit.

## **Section 23 - City's Right To Do Work**

If the Contractor should neglect to prosecute the work properly or fail to perform any provision of this Contract, the City, 3 days after giving written notice to the Contractor and its surety may, without prejudice to any other remedy the City may have, make good the deficiencies and may deduct the cost from the payment due to the Contractor.

## **Section 24 - Removal of Equipment and Supplies**

In case of termination of this Contract before completion, from any or no cause, the Contractor, if notified to do so by the City, shall promptly remove any part or all of its equipment and supplies from the property of the City, failing which the City shall have the right to remove the equipment and supplies at the expense of the Contractor.

The removed equipment and supplies may be stored by the City and, if all costs of removal and storage are not paid by the Contractor within 10 days of invoicing, the City upon 10 days written notice may sell the equipment and supplies at auction or private sale, and shall pay the Contractor the net proceeds after deducting all costs and expenses that should have been borne by the Contractor and after deducting all amounts claimed due by any lien holder of the equipment or supplies.

## **Section 25 - Responsibility for Work and Warranties**

The Contractor assumes full responsibility for any and all materials and equipment used in the construction of the work and may not make claims against the City for damages to materials and equipment from any cause except negligence or willful act of the City. Until its final acceptance, the Contractor shall be responsible for damage to or destruction of the project (except for any part covered by Partial Completion and Acceptance - Section 26). The Contractor shall make good all work damaged or destroyed before acceptance. All risk of loss remains with the Contractor until final acceptance of the work (Section 19) or partial acceptance (Section 26). The Contractor is advised to investigate obtaining its own builders risk insurance.

The Contractor shall guarantee the quality of the work for a period of one year. The Contractor shall also unconditionally guarantee the quality of all equipment and materials that are furnished and installed under the contract for a period of one year. At the end of one year after the Contractor's receipt of final payment, the complete work, including equipment and materials furnished and installed under the contract, shall be inspected by the Contractor and the Supervising Professional. Any defects shall be corrected by the Contractor at its expense as soon as practicable but in all cases within 60 days. Any defects that are identified prior to the end of one year shall also be inspected by the Contractor and the Supervising Professional and shall be corrected by the Contractor at its expense as soon as practicable but in all cases within 60 days.

The Contractor shall assign all manufacturer or material supplier warranties to the City prior to final payment. The assignment shall not relieve the Contractor of its obligations under this paragraph to correct defects.



## **Section 26 - Partial Completion and Acceptance**

If at any time prior to the issuance of the final certificate referred to in Acceptance and Final Payment - Section 19, any portion of the permanent construction has been satisfactorily completed, and if the Supervising Professional determines that portion of the permanent construction is not required for the operations of the Contractor but is needed by the City, the Supervising Professional shall issue to the Contractor a certificate of partial completion, and immediately the City may take over and use the portion of the permanent construction described in the certificate, and exclude the Contractor from that portion.

The issuance of a certificate of partial completion shall not constitute an extension of the Contractor's time to complete the portion of the permanent construction to which it relates if the Contractor has failed to complete it in accordance with the terms of this Contract. The issuance of the certificate shall not release the Contractor or its sureties from any obligations under this Contract including bonds.

If prior use increases the cost of, or delays the work, the Contractor shall be entitled to extra compensation, or extension of time, or both, as the Supervising Professional may determine.

## **Section 27 - Payments Withheld Prior to Final Acceptance of Work**

The City may withhold or, on account of subsequently discovered evidence, nullify the whole or part of any certificate to the extent reasonably appropriate to protect the City from loss on account of:

- (1) Defective work not remedied;
- (2) Claims filed or reasonable evidence indicating probable filing of claims by other parties against the Contractor;
- (3) Failure of the Contractor to make payments properly to subcontractors or for material or labor;
- (4) Damage to another Contractor.

When the above grounds are removed or the Contractor provides a Surety Bond satisfactory to the City which will protect the City in the amount withheld, payment shall be made for amounts withheld under this section.

## **Section 28 - Contractor's Insurance**

- (1) The Contractor shall procure and maintain during the life of this Contract, including the guarantee period and during any warranty work, such insurance policies, including those set forth below, as will protect itself and the City from all claims for bodily injuries, death or property damage which may arise under this Contract; whether the act(s) or omission(s) giving rise to the claim were made by the Contractor or by any subcontractor or anyone employed by them directly or indirectly. In the case of all contracts involving on-site work, the Contractor shall provide to the City, before the commencement of any work under this contract, certificates of insurance and other documentation satisfactory to the City demonstrating it has obtained the policies and endorsements required on behalf of itself, and when requested, any subcontractor(s). The certificates of insurance endorsements and/or copies of policy language shall document that the Contractor satisfies the following minimum requirements.

- (a) Worker's Compensation Insurance in accordance with all applicable state and federal statutes. Further, Employers Liability Coverage shall be obtained in the following minimum amounts:

Bodily Injury by Accident - \$500,000 each accident  
Bodily Injury by Disease - \$500,000 each employee  
Bodily Injury by Disease - \$500,000 each policy limit

- (b) Commercial General Liability Insurance equivalent to, as a minimum, Insurance Services Office form CG 00 01 07 98 or current equivalent. The City of Ann Arbor shall be named as an additional insured. There shall be no added exclusions or limiting endorsements specifically for the following coverages: Products and Completed Operations, Explosion, Collapse and Underground coverage or Pollution. Further there shall be no added exclusions or limiting endorsements which diminish the City's protections as an additional insured under the policy. The following minimum limits of liability are required:

\$1,000,000	Each occurrence as respect Bodily Injury Liability or Property Damage Liability, or both combined.
\$2,000,000	Per Job General Aggregate
\$1,000,000	Personal and Advertising Injury
\$2,000,000	Products and Completed Operations Aggregate

- (c) Motor Vehicle Liability Insurance, including Michigan No-Fault Coverages, equivalent to, as a minimum, Insurance Services Office form CA 00 01 07 97 or current equivalent. Coverage shall include all owned vehicles, all non-owned vehicles and all hired vehicles. The City of Ann Arbor shall be named as an additional insured. There shall be no added exclusions or limiting endorsements which diminish the City's protections as an additional insured under the policy. Further, the limits of liability shall be \$1,000,000 for each occurrence as respects Bodily Injury Liability or Property Damage Liability, or both combined.

- (d) Umbrella/Excess Liability Insurance shall be provided to apply excess of the Commercial General Liability, Employers Liability and the Motor Vehicle coverage enumerated above, for each occurrence and for aggregate in the amount of \$1,000,000.

- (2) Insurance required under subsection (1)(b) and (1)(c) above shall be considered primary as respects any other valid or collectible insurance that the City may possess, including any self-insured retentions the City may have; and any other insurance the City does possess shall be considered excess insurance only and shall not be required to contribute with this insurance. Further, the Contractor agrees to waive any right of recovery by its insurer against the City.
- (3) Insurance companies and policy forms are subject to approval of the City Attorney, which approval shall not be unreasonably withheld. Documentation must provide and demonstrate an unconditional 30 day written notice of cancellation in favor of the City of Ann Arbor. Further, the documentation must explicitly state the following: (a) the policy number; name of insurance company; name and address of the agent or authorized representative; name and address of insured; project name; policy expiration date; and specific coverage amounts; (b) any deductibles or self-insured retentions which shall be approved by the City, in its sole discretion; (c) that the policy conforms to the requirements specified Contractor shall furnish the City with satisfactory certificates of insurance and endorsements prior to commencement of any work. Upon request, the Contractor shall provide within 30 days a copy of the policy(ies) to the City. If any of the above coverages expire by their terms during the term of this Contract, the Contractor shall deliver proof of renewal and/or new policies and endorsements to the Administering

Service Area/Unit at least ten days prior to the expiration date.

- (4) Any Insurance provider of Contractor shall be admitted and authorized to do business in the State of Michigan and shall carry and maintain a minimum rating assigned by A.M. Best & Company's Key Rating Guide of "A-" Overall and a minimum Financial Size Category of "V". Insurance policies and certificates issued by non-admitted insurance companies are not acceptable unless approved in writing by the City.
- (5) City reserves the right to require additional coverage and/or coverage amounts as may be included from time to time in the Detailed Specifications for the Project.
- (6) The provisions of General Condition 28 shall survive the expiration or earlier termination of this contract for any reason.

## **Section 29 - Surety Bonds**

Bonds will be required from the successful bidder as follows:

- (1) A Performance Bond to the City of Ann Arbor for the amount of the bid(s) accepted;
- (2) A Labor and Material Bond to the City of Ann Arbor for the amount of the bid(s) accepted.

Bonds shall be executed on forms supplied by the City in a manner and by a Surety Company authorized to transact business in Michigan and satisfactory to the City Attorney.

## **Section 30 - Damage Claims**

The Contractor shall be held responsible for all damages to property of the City or others, caused by or resulting from the negligence of the Contractor, its employees, or agents during the progress of or connected with the prosecution of the work, whether within the limits of the work or elsewhere. The Contractor must restore all property injured including sidewalks, curbing, sodding, pipes, conduit, sewers or other public or private property to not less than its original condition with new work.

## **Section 31 - Refusal to Obey Instructions**

If the Contractor refuses to obey the instructions of the Supervising Professional, the Supervising Professional shall withdraw inspection from the work, and no payments will be made for work performed thereafter nor may work be performed thereafter until the Supervising Professional shall have again authorized the work to proceed.

## **Section 32 - Assignment**

Neither party to the Contract shall assign the Contract without the written consent of the other. The Contractor may assign any monies due to it to a third party acceptable to the City.

## **Section 33 - Rights of Various Interests**

Whenever work being done by the City's forces or by other contractors is contiguous to work covered by this Contract, the respective rights of the various interests involved shall be established by the Supervising Professional, to secure the completion of the various portions of the work in general harmony.

The Contractor is responsible to coordinate all aspects of the work, including coordination of, and with, utility companies and other contractors whose work impacts this project.

### **Section 34 - Subcontracts**

The Contractor shall not award any work to any subcontractor without prior written approval of the City. The approval will not be given until the Contractor submits to the City a written statement concerning the proposed award to the subcontractor. The statement shall contain all information the City may require.

The Contractor shall be as fully responsible to the City for the acts and omissions of its subcontractors, and of persons either directly or indirectly employed by them, as it is for the acts and omissions of persons directly employed by it.

The Contractor shall cause appropriate provisions to be inserted in all subcontracts relative to the work to bind subcontractors to the Contractor by the terms of the General Conditions and all other contract documents applicable to the work of the subcontractors and to give the Contractor the same power to terminate any subcontract that the City may exercise over the Contractor under any provision of the contract documents.

Nothing contained in the contract documents shall create any contractual relation between any subcontractor and the City.

### **Section 35 - Supervising Professional's Status**

The Supervising Professional has the right to inspect any or all work. The Supervising Professional has authority to stop the work whenever stoppage may be appropriate to insure the proper execution of the Contract. The Supervising Professional has the authority to reject all work and materials which do not conform to the Contract and to decide questions which arise in the execution of the work.

The Supervising Professional shall make all measurements and determinations of quantities. Those measurements and determinations are final and conclusive between the parties.

### **Section 36 - Supervising Professional's Decisions**

The Supervising Professional shall, within a reasonable time after their presentation to the Supervising Professional, make decisions in writing on all claims of the City or the Contractor and on all other matters relating to the execution and progress of the work or the interpretation of the contract documents.

### **Section 37 - Storing Materials and Supplies**

Materials and supplies may be stored at the site of the work at locations agreeable to the City unless specific exception is listed elsewhere in these documents. Ample way for foot traffic and drainage must be provided, and gutters must, at all times, be kept free from obstruction. Traffic on streets shall be interfered with as little as possible. The Contractor may not enter or occupy with agents, employees, tools, or material any private property without first obtaining written permission from its owner. A copy of the permission shall be furnished to the Supervising Professional.

### **Section 38 - Lands for Work**

The Contractor shall provide, at its own expense and without liability to the City, any additional land and access that may be required for temporary construction facilities or for storage of

materials.

### **Section 39 - Cleaning Up**

The Contractor shall, as directed by the Supervising Professional, remove at its own expense from the City's property and from all public and private property all temporary structures, rubbish and waste materials resulting from its operations unless otherwise specifically approved, in writing, by the Supervising Professional.

### **Section 40 - Salvage**

The Supervising Professional may designate for salvage any materials from existing structures or underground services. Materials so designated remain City property and shall be transported or stored at a location as the Supervising Professional may direct.

### **Section 41 - Night, Saturday or Sunday Work**

No night or Sunday work (without prior written City approval) will be permitted except in the case of an emergency and then only to the extent absolutely necessary. The City may allow night work which, in the opinion of the Supervising Professional, can be satisfactorily performed at night. Night work is any work between 8:00 p.m. and 7:00 a.m. No Saturday work will be permitted unless the Contractor gives the Supervising Professional at least 48 hours but not more than 5 days notice of the Contractor's intention to work the upcoming Saturday.

### **Section 42 - Sales Taxes**

Under State law the City is exempt from the assessment of State Sales Tax on its direct purchases. Contractors who acquire materials, equipment, supplies, etc. for incorporation in City projects are not likewise exempt. State Law shall prevail. The Bidder shall familiarize itself with the State Law and prepare its Bid accordingly. No extra payment will be allowed under this Contract for failure of the Contractor to make proper allowance in this bid for taxes it must pay.

## Section 43

### CONTRACTOR'S DECLARATION

I hereby declare that I have not, during the period \_\_\_\_\_, 20\_\_\_\_, to \_\_\_\_\_, 20\_\_\_\_, performed any work, furnished any materials, sustained any loss, damage or delay, or otherwise done anything in addition to the regular items (or executed change orders) set forth in the Contract titled \_\_\_\_\_, for which I shall ask, demand, sue for, or claim compensation or extension of time from the City, except as I hereby make claim for additional compensation or extension of time as set forth on the attached itemized statement. I further declare that I have paid all payroll obligations related to this Contract that have become due during the above period and that all invoices related to this Contract received more than 30 days prior to this declaration have been paid in full except as listed below.

There is/is not (Contractor please circle one and strike one as appropriate) an itemized statement attached regarding a request for additional compensation or extension of time.

\_\_\_\_\_  
Contractor

\_\_\_\_\_  
Date

By \_\_\_\_\_  
(Signature)

Its \_\_\_\_\_  
(Title of Office)

Past due invoices, if any, are listed below.



## **STANDARD SPECIFICATIONS**

All work under this contract shall be performed in accordance with the Public Services Department Standard Specifications in effect at the date of availability of the contract documents stipulated in the Bid. All work under this Contract which is not included in these Standard Specifications, or which is performed using modifications to these Standard Specifications, shall be performed in accordance with the Detailed Specifications included in these contract documents.

Standard Specifications are available online:

<http://www.a2gov.org/departments/engineering/Pages/Engineering-and-Contractor-Resources.aspx>



# APPENDIX

**CITY OF ANN ARBOR  
PREVAILING WAGE DECLARATION OF COMPLIANCE**

The “wage and employment requirements” of Section 1:320 of Chapter 14 of Title I of the Ann Arbor City Code mandates that the city not enter any contract, understanding or other arrangement for a public improvement for or on behalf of the city unless the contract provides that all craftsmen, mechanics and laborers employed directly on the site in connection with said improvements, including said employees of subcontractors, shall receive the prevailing wage for the corresponding classes of craftsmen, mechanics and laborers, as determined by statistics for the Ann Arbor area compiled by the United States Department of Labor. Where the contract and the Ann Arbor City Code are silent as to definitions of terms required in determining contract compliance with regard to prevailing wages, the definitions provided in the Davis-Bacon Act as amended (40 U.S.C. 278-a to 276-a-7) for the terms shall be used. Further, to the extent that any employees of the contractor providing services under this contract are not part of the class of craftsmen, mechanics and laborers who receive a prevailing wage in conformance with section 1:320 of Chapter 14 of Title I of the Code of the City of Ann Arbor, employees shall be paid a prescribed minimum level of compensation (i.e. Living Wage) for the time those employees perform work on the contract in conformance with section 1:815 of Chapter 23 of Title I of the Code of the City of Ann Arbor.

At the request of the city, any contractor or subcontractor shall provide satisfactory proof of compliance with this provision.

The Contractor agrees:

- (a) To pay each of its employees whose wage level is required to comply with federal, state or local prevailing wage law, for work covered or funded by this contract with the City,
- (b) To require each subcontractor performing work covered or funded by this contract with the City to pay each of its employees the applicable prescribed wage level under the conditions stated in subsection (a) or (b) above.
- (c) To provide to the City payroll records or other documentation within ten (10) business days from the receipt of a request by the City.
- (d) To permit access to work sites to City representatives for the purposes of monitoring compliance, and investigating complaints or non-compliance.

The undersigned states that he/she has the requisite authority to act on behalf of his/her employer in these matters and has offered to provide the services in accordance with the terms of the wage and employment provisions of the Chapter 14 of the Ann Arbor City Code. The undersigned certifies that he/she has read and is familiar with the terms of Section 1:320 of Chapter 14 of the Ann Arbor City Code and by executing this Declaration of Compliance obligates his/her employer and any subcontractor employed by it to perform work on the contract to the wage and employment requirements stated herein. The undersigned further acknowledges and agrees that if it is found to be in violation of the wage and employment requirements of Section 1:320 of the Chapter 14 of the Ann Arbor City Code it shall be deemed a material breach of the terms of the contract and grounds for termination of same by the City.

\_\_\_\_\_  
Company Name

\_\_\_\_\_  
Signature of Authorized Representative

\_\_\_\_\_  
Date

\_\_\_\_\_  
Print Name and Title

\_\_\_\_\_  
Address, City, State, Zip

\_\_\_\_\_  
Phone/Email address

Questions about this form? Contact Procurement Office City of Ann Arbor Phone: 734/794-6500

**CITY OF ANN ARBOR  
LIVING WAGE ORDINANCE DECLARATION OF COMPLIANCE**

The Ann Arbor Living Wage Ordinance (Section 1:811-1:821 of Chapter 23 of Title I of the Code) requires that an employer who is (a) a contractor providing services to or for the City for a value greater than \$10,000 for any twelve-month contract term, or (b) a recipient of federal, state, or local grant funding administered by the City for a value greater than \$10,000, or (c) a recipient of financial assistance awarded by the City for a value greater than \$10,000, shall pay its employees a prescribed minimum level of compensation (i.e., Living Wage) for the time those employees perform work on the contract or in connection with the grant or financial assistance. The Living Wage must be paid to these employees for the length of the contract/program.

*Companies employing fewer than 5 persons and non-profits employing fewer than 10 persons are exempt from compliance with the Living Wage Ordinance. If this exemption applies to your company/non-profit agency please check here [ ] No. of employees \_\_\_\_*

The Contractor or Grantee agrees:

- (a) To pay each of its employees whose wage level is not required to comply with federal, state or local prevailing wage law, for work covered or funded by a contract with or grant from the City, no less than the Living Wage. The current Living Wage is defined as \$12.93/hour for those employers that provide employee health care (as defined in the Ordinance at Section 1:815 Sec. 1 (a)), or no less than \$14.43/hour for those employers that do not provide health care. The Contractor or Grantor understands that the Living Wage is adjusted and established annually on April 30 in accordance with the Ordinance and covered employers shall be required to pay the adjusted amount thereafter to be in compliance (Section 1:815(3)).

**Check the applicable box below which applies to your workforce**

- [ ] Employees who are assigned to any covered City contract/grant will be paid at or above the applicable living wage without health benefits
- [ ] Employees who are assigned to any covered City contract/grant will be paid at or above the applicable living wage with health benefits
- (b) To post a notice approved by the City regarding the applicability of the Living Wage Ordinance in every work place or other location in which employees or other persons contracting for employment are working.
- (c) To provide to the City payroll records or other documentation within ten (10) business days from the receipt of a request by the City.
- (d) To permit access to work sites to City representatives for the purposes of monitoring compliance, and investigating complaints or non-compliance.
- (e) To take no action that would reduce the compensation, wages, fringe benefits, or leave available to any employee covered by the Living Wage Ordinance or any person contracted for employment and covered by the Living Wage Ordinance in order to pay the living wage required by the Living Wage Ordinance.

The undersigned states that he/she has the requisite authority to act on behalf of his/her employer in these matters and has offered to provide the services or agrees to accept financial assistance in accordance with the terms of the Living Wage Ordinance. The undersigned certifies that he/she has read and is familiar with the terms of the Living Wage Ordinance, obligates the Employer/Grantee to those terms and acknowledges that if his/her employer is found to be in violation of Ordinance it may be subject to civil penalties and termination of the awarded contract or grant of financial assistance.

\_\_\_\_\_  
Company Name

\_\_\_\_\_  
Signature of Authorized Representative

\_\_\_\_\_  
Date

\_\_\_\_\_  
Print Name and Title

\_\_\_\_\_  
Address, City, State, Zip

\_\_\_\_\_  
Phone/Email address

Questions about this form? Contact Procurement Office City of Ann Arbor Phone: 734/794-6500

# CITY OF ANN ARBOR LIVING WAGE ORDINANCE

**RATE EFFECTIVE APRIL 30, 2016 - ENDING APRIL 29, 2017**

**\$12.93 per hour**

If the employer provides health care benefits\*

**\$14.43 per hour**

If the employer does **NOT** provide health care benefits\*

Employers providing services to or for the City of Ann Arbor or recipients of grants or financial assistance from the City of Ann Arbor for a value of more than \$10,000 in a twelve-month period of time must pay those employees performing work on a City of Ann Arbor contract or grant, the above living wage.

## **ENFORCEMENT**

The City of Ann Arbor may recover back wages either administratively or through court action for the employees that have been underpaid in violation of the law. Persons denied payment of the living wage have the right to bring a civil action for damages in addition to any action taken by the City.

Violation of this Ordinance is punishable by fines of not more than \$500/violation plus costs, with each day being considered a separate violation. Additionally, the City of Ann Arbor has the right to modify, terminate, cancel or suspend a contract in the event of a violation of the Ordinance.

\* Health Care benefits include those paid for by the employer or making an employer contribution toward the purchase of health care. The employee contribution must not exceed \$.50 an hour for an average work week; and the employer cost or contribution must equal no less than \$1/hr for the average work week.

**The Law Requires Employers to Display This Poster Where Employees Can Readily See It.**

**For Additional Information or to File a Complaint Contact:  
Colin Spencer at 734/794-6500 or [cspencer@a2gov.org](mailto:cspencer@a2gov.org)**



Vendor Conflict of Interest Disclosure Form

All vendors interested in conducting business with the City of Ann Arbor must complete and return the Vendor Conflict of Interest Disclosure Form in order to be eligible to be awarded a contract. Please note that all vendors are subject to comply with the City of Ann Arbor's conflict interest policies as stated within the certification section below.

If a vendor has a relationship with a City of Ann Arbor official or employee, an immediate family member of a City of Ann Arbor official or employee, the vendor shall disclose the information required below.

Certification: I hereby certify that to my knowledge, there is no conflict of interest involving the vendor named below:

- 1. No City official or employee or City employee's immediate family member has an ownership interest in vendor's company or is deriving personal financial gain from this contract.
2. No retired or separated City official or employee who has been retired or separated from the City for less than one (1) year has an ownership interest in vendor's Company.
3. No City employee is contemporaneously employed or prospectively to be employed with the vendor.
4. Vendor hereby declares it has not and will not provide gifts or hospitality of any dollar value or any other gratuities to any City employee or elected official to obtain or maintain a contract.
5. Please note any exceptions below:

Table with 2 columns: Vendor Name, Vendor Phone Number. Includes a section for Conflict of Interest Disclosure with checkboxes for Relationship to employee, Interest in vendor's company, and Other.

\*Disclosing a potential conflict of interest does not disqualify vendors. In the event vendors do not disclose potential conflicts of interest and they are detected by the City, vendor will be exempt from doing business with the City.

I certify that the information provided is true and correct by my signature below:

Signature of Vendor Authorized Representative Date Printed Name of Vendor Authorized Representative

PROCUREMENT USE ONLY

- Yes, named employee was involved in Bid / Proposal process.
No, named employee was not involved in procurement process or decision.

**CITY OF ANN ARBOR  
DECLARATION OF COMPLIANCE**

Non-Discrimination Ordinance

The "non discrimination by city contractors" provision of the City of Ann Arbor Non-Discrimination Ordinance (Ann Arbor City Code Chapter 112, Section 9:158) requires all contractors proposing to do business with the City to treat employees in a manner which provides equal employment opportunity and does not discriminate against any of their employees, any City employee working with them, or any applicant for employment on the basis of actual or perceived age, arrest record, color, disability, educational association, familial status, family responsibilities, gender expression, gender identity, genetic information, height, HIV status, marital status, national origin, political beliefs, race, religion, sex, sexual orientation, source of income, veteran status, victim of domestic violence or stalking, or weight. It also requires that the contractors include a similar provision in all subcontracts that they execute for City work or programs.

In addition the City Non-Discrimination Ordinance requires that all contractors proposing to do business with the City of Ann Arbor must satisfy the contract compliance administrative policy adopted by the City Administrator. A copy of that policy may be obtained from the Purchasing Manager

The Contractor agrees:

- (a) To comply with the terms of the City of Ann Arbor's Non-Discrimination Ordinance and contract compliance administrative policy.
- (b) To post the City of Ann Arbor's Non-Discrimination Ordinance Notice in every work place or other location in which employees or other persons are contracted to provide services under a contract with the City.
- (c) To provide documentation within the specified time frame in connection with any workforce verification, compliance review or complaint investigation.
- (d) To permit access to employees and work sites to City representatives for the purposes of monitoring compliance, or investigating complaints of non-compliance.

The undersigned states that he/she has the requisite authority to act on behalf of his/her employer in these matters and has offered to provide the services in accordance with the terms of the Ann Arbor Non-Discrimination Ordinance. The undersigned certifies that he/she has read and is familiar with the terms of the Non-Discrimination Ordinance, obligates the Contractor to those terms and acknowledges that if his/her employer is found to be in violation of Ordinance it may be subject to civil penalties and termination of the awarded contract.

---

Company Name

---

Signature of Authorized Representative

Date

---

Print Name and Title

---

Address, City, State, Zip

---

Phone/Email address

**Questions about the Notice or the City Administrative Policy, Please contact:**  
Procurement Office of the City of Ann Arbor  
(734) 794-6500

# CITY OF ANN ARBOR NON-DISCRIMINATION ORDINANCE

Relevant provisions of Chapter 112, Nondiscrimination, of the Ann Arbor City Code are included below. You can review the entire ordinance at [www.a2gov.org/departments/city-clerk](http://www.a2gov.org/departments/city-clerk)

Intent: It is the intent of the city that no individual be denied equal protection of the laws; nor shall any individual be denied the enjoyment of his or her civil or political rights or be discriminated against because of actual or perceived age, arrest record, color, disability, educational association, familial status, family responsibilities, gender expression, gender identity, genetic information, height, HIV status, marital status, national origin, political beliefs, race, religion, sex, sexual orientation, source of income, veteran status, victim of domestic violence or stalking, or weight.

Discriminatory Employment Practices: No person shall discriminate in the hire, employment, compensation, work classifications, conditions or terms, promotion or demotion, or termination of employment of any individual. No person shall discriminate in limiting membership, conditions of membership or termination of membership in any labor union or apprenticeship program.

Discriminatory Effects: No person shall adopt, enforce or employ any policy or requirement which has the effect of creating unequal opportunities according to actual or perceived age, arrest record, color, disability, educational association, familial status, family responsibilities, gender expression, gender identity, genetic information, height, HIV status, marital status, national origin, political beliefs, race, religion, sex, sexual orientation, source of income, veteran status, victim of domestic violence or stalking, or weight for an individual to obtain housing, employment or public accommodation, except for a bona fide business necessity. Such a necessity does not arise due to a mere inconvenience or because of suspected objection to such a person by neighbors, customers or other persons.

Nondiscrimination by City Contractors: All contractors proposing to do business with the City of Ann Arbor shall satisfy the contract compliance administrative policy adopted by the City Administrator in accordance with the guidelines of this section. All city contractors shall ensure that applicants are employed and that employees are treated during employment in a manner which provides equal employment opportunity and tends to eliminate inequality based upon any classification protected by this chapter. All contractors shall agree not to discriminate against an employee or applicant for employment with respect to hire, tenure, terms, conditions, or privileges of employment, or a matter directly or indirectly related to employment, because of any applicable protected classification. All contractors shall be required to post a copy of Ann Arbor's Non-Discrimination Ordinance at all work locations where its employees provide services under a contract with the city.

Complaint Procedure: If any individual has a grievance alleging a violation of this chapter, he/she has 180 calendar days from the date of the individual's knowledge of the allegedly discriminatory action or 180 calendar days from the date when the individual should have known of the alleged discriminatory action to file a complaint with the city's Human Rights Commission. If an individual fails to file a complaint alleging a violation of this chapter within the specified time frame, the complaint will not be considered by the Human Rights Commission. The complaint should be made in writing to the Human Rights Commission. The complaint may be filed in person with the City Clerk, by e-mail at [aahumanrightscommission@gmail.com](mailto:aahumanrightscommission@gmail.com), or by mail (Ann Arbor Human Rights Commission, PO Box 8647, Ann Arbor, MI 48107). The complaint must contain information about the alleged discrimination, such as name, address, phone number of the complainant and location, date and description of the alleged violation of this chapter.

Private Actions For Damages or Injunctive Relief: To the extent allowed by law, an individual who is the victim of discriminatory action in violation of this chapter may bring a civil action for appropriate injunctive relief or damages or both against the person(s) who acted in violation of this chapter

## **ATTACHMENTS**



General Decision Number: MI170100 02/24/2017 MI100

Superseded General Decision Number: MI20160100

State: Michigan

Construction Type: Building

County: Washtenaw County in Michigan.

BUILDING CONSTRUCTION PROJECTS (does not include single family homes or apartments up to and including 4 stories).

Note: Under Executive Order (EO) 13658, an hourly minimum wage of \$10.20 for calendar year 2017 applies to all contracts subject to the Davis-Bacon Act for which the contract is awarded (and any solicitation was issued) on or after January 1, 2015. If this contract is covered by the EO, the contractor must pay all workers in any classification listed on this wage determination at least \$10.20 (or the applicable wage rate listed on this wage determination, if it is higher) for all hours spent performing on the contract in calendar year 2017. The EO minimum wage rate will be adjusted annually. Additional information on contractor requirements and worker protections under the EO is available at [www.dol.gov/whd/govcontracts](http://www.dol.gov/whd/govcontracts).

Modification Number	Publication Date
0	01/06/2017
1	01/20/2017
2	02/03/2017
3	02/24/2017

ASBE0025-003 06/01/2016

Townships of Ann Arbor, Augusta, Lodi, Northfield, Pittsfield, Salem, Saline, Scio, Superior, Webster, Ypsilanti & York

	Rates	Fringes
ASBESTOS WORKER/HEAT & FROST INSULATOR.....	\$ 31.51	31.04

ASBE0047-001 07/01/2016

Townships of Bridgewater, Dexter, Freedom, Lims, Lyndon, Manchester, Sharon & Sylvan

	Rates	Fringes
ASBESTOS WORKER/HEAT & FROST INSULATOR.....	\$ 30.22	16.48

BOIL0169-001 01/01/2014

	Rates	Fringes
BOILERMAKER.....	\$ 32.78	28.39

-----  
BRMI0009-010 08/01/2016

	Rates	Fringes
BRICKLAYER.....	\$ 33.70	20.37
TILE FINISHER.....	\$ 26.65	18.21
TILE SETTER.....	\$ 33.00	18.21

-----  
CARP0687-001 06/01/2016

	Rates	Fringes
CARPENTER, Includes Drywall Hanging, Form Work, and Metal Stud Installation.....	\$ 31.16	26.56

-----  
CARP1045-001 06/01/2016

	Rates	Fringes
CARPENTER (Floor Layer - Carpet, Resilient, & Vinyl Flooring).....	\$ 28.00	23.02

-----  
CARP1102-002 06/01/2013

	Rates	Fringes
MILLWRIGHT.....	\$ 31.11	28.64

-----  
ELEC0252-010 06/14/2016

	Rates	Fringes
ELECTRICIAN.....	\$ 34.58	25.22

-----  
ENGI0324-017 06/01/2016

	Rates	Fringes
OPERATOR: Power Equipment		
GROUP 1.....	\$ 39.64	22.90
GROUP 2.....	\$ 38.14	22.90
GROUP 3.....	\$ 36.64	22.90
GROUP 4.....	\$ 36.34	22.90
GROUP 5.....	\$ 35.52	22.90
GROUP 6.....	\$ 34.66	22.90
GROUP 7.....	\$ 33.69	22.90
GROUP 8.....	\$ 31.98	22.90
GROUP 9.....	\$ 23.64	22.90

FOOTNOTES:

Tower cranes: to be paid the crane operator rate determined by the combined length of the mast and the boom. If the worker must climb 50 ft. or more to the work station, \$.25 per hour additional.

Derrick and cranes where the operator must climb 50 ft. or more to the work station, \$.25 per hour additional to the applicable crane operator rate.

POWER EQUIPMENT OPERATOR CLASSIFICATIONS

GROUP 1: Crane with boom and jib or leads 400' or longer

GROUP 2: Crane with boom and jib or leads 300' or longer

GROUP 3: Crane with boom and jib or leads 220' or longer

GROUP 4: Crane with boom and jib or leads 140' or longer

GROUP 5: Crane with boom and jib or leads 120' or longer

GROUP 6: Regular crane operator, and concrete pump with boom operator

GROUP 7: Backhoe/Excavator/Trackhoe, bobcat/skid Loader, broom/sweeper, bulldozer, grader/blade, highlift, hoist, loader, roller, scraper, tractor & trencher

GROUP 8: Forklift & extend-a-boom forklift

GROUP 9: Oiler

-----  
IRON0025-019 06/01/2015

	Rates	Fringes
IRONWORKER		
REINFORCING.....	\$ 28.30	24.60
STRUCTURAL.....	\$ 33.78	27.84

-----  
LABO0334-005 06/01/2015

	Rates	Fringes
LABORER: Landscape & Irrigation		
GROUP 1.....	\$ 19.76	9.15
GROUP 2.....	\$ 15.54	9.15

CLASSIFICATIONS

GROUP 1: Landscape specialist, including air, gas and diesel equipment operator, lawn sprinkler installer, skidsteer (or equivalent)

GROUP 2: Landscape laborer: small power tool operator,  
 material mover, truck driver and lawn sprinkler installer  
 tender

-----  
 LABO0499-005 08/01/2014

	Rates	Fringes
LABORER		
Common or General; Grade Checker; Sandblaster.....	\$ 28.32	13.85
Mason Tender - Brick; Mason Tender - Cement/Concrete.....	\$ 28.52	13.85
Pipelayer.....	\$ 28.64	13.85

-----  
 PAIN0022-003 06/01/2015

	Rates	Fringes
PAINTER: Brush and Roller.....	\$ 26.06	17.66
PAINTER: Drywall Finishing/Taping.....	\$ 27.05	18.26
PAINTER: Spray.....	\$ 26.86	17.66

-----  
 PAIN0357-002 06/01/2015

	Rates	Fringes
GLAZIER.....	\$ 30.05	18.10

PAID HOLIDAYS: New Year's Day, Decoration Day, Fourth of  
 July, Labor Day, Thanksgiving Day and Christmas Day;  
 provided that the employee has worked the last full regular  
 scheduled work day prior to the holiday, and the first full  
 regular scheduled work day following the holiday, provided  
 the employee is physically able to work.

-----  
 PLAS0514-006 05/01/2016

	Rates	Fringes
CEMENT MASON/CONCRETE FINISHER...	\$ 31.55	14.80

-----  
 PLUM0190-004 06/01/2016

	Rates	Fringes
PIPEFITTER (Including HVAC Pipe Installation; Excluding HVAC System Installation).....	\$ 38.99	21.06
PLUMBER, Excludes HVAC Pipe and Unit Installation.....	\$ 38.99	21.06

-----  
 ROOF0070-001 06/01/2016

	Rates	Fringes
ROOFER.....	\$ 31.37	15.98

-----  
 SFMI0704-001 01/01/2017

	Rates	Fringes
SPRINKLER FITTER (Fire Sprinklers).....	\$ 43.25	22.42

-----  
 SHEE0080-001 07/01/2015

	Rates	Fringes
SHEET METAL WORKER, Includes HVAC Duct and Unit Installation.....	\$ 37.24	26.56

-----  
 \* TEAM0247-001 06/01/2016

	Rates	Fringes
TRUCK DRIVER GROUP 1 Flatbed; Pickup; Dump & Tandem.....	\$ 25.94	0.60+a
GROUP 2 Semi.....	\$ 26.09	0.60+a
GROUP 3 Lowboy.....	\$ 26.19	0.60+a

PAID HOLIDAYS: New Year's Day, Memorial Day, Independence Day, Labor Day, Thanksgiving Day and Christmas Day. If any of the above holidays fall on a Sunday, the following Monday shall be considered the holiday and, if work is performed, the rate shall be double time.

FOOTNOTE:  
 a. \$418.45 per week, plus \$62.00 per day.

-----  
 SUMI2011-025 02/01/2011

	Rates	Fringes
IRONWORKER, ORNAMENTAL.....	\$ 18.48	7.93
TRUCK DRIVER: Tractor Haul Truck.....	\$ 13.57	1.18

-----  
 WELDERS - Receive rate prescribed for craft performing operation to which welding is incidental.

=====

Note: Executive Order (EO) 13706, Establishing Paid Sick Leave for Federal Contractors applies to all contracts subject to the Davis-Bacon Act for which the contract is awarded (and any solicitation was issued) on or after January 1, 2017. If this contract is covered by the EO, the contractor must provide employees with 1 hour of paid sick leave for every 30 hours they work, up to 56 hours of paid sick leave each year. Employees must be permitted to use paid sick leave for their own illness, injury or other health-related needs, including preventive care; to assist a family member (or person who is like family to the employee) who is ill, injured, or has other health-related needs, including preventive care; or for reasons resulting from, or to assist a family member (or person who is like family to the employee) who is a victim of, domestic violence, sexual assault, or stalking. Additional information on contractor requirements and worker protections under the EO is available at [www.dol.gov/whd/govcontracts](http://www.dol.gov/whd/govcontracts).

Unlisted classifications needed for work not included within the scope of the classifications listed may be added after award only as provided in the labor standards contract clauses (29CFR 5.5 (a) (1) (ii)).

-----

The body of each wage determination lists the classification and wage rates that have been found to be prevailing for the cited type(s) of construction in the area covered by the wage determination. The classifications are listed in alphabetical order of "identifiers" that indicate whether the particular rate is a union rate (current union negotiated rate for local), a survey rate (weighted average rate) or a union average rate (weighted union average rate).

#### Union Rate Identifiers

A four letter classification abbreviation identifier enclosed in dotted lines beginning with characters other than "SU" or "UAVG" denotes that the union classification and rate were prevailing for that classification in the survey. Example: PLUM0198-005 07/01/2014. PLUM is an abbreviation identifier of the union which prevailed in the survey for this classification, which in this example would be Plumbers. 0198 indicates the local union number or district council number where applicable, i.e., Plumbers Local 0198. The next number, 005 in the example, is an internal number used in processing the wage determination. 07/01/2014 is the effective date of the most current negotiated rate, which in this example is July 1, 2014.

Union prevailing wage rates are updated to reflect all rate changes in the collective bargaining agreement (CBA) governing this classification and rate.

## Survey Rate Identifiers

Classifications listed under the "SU" identifier indicate that no one rate prevailed for this classification in the survey and the published rate is derived by computing a weighted average rate based on all the rates reported in the survey for that classification. As this weighted average rate includes all rates reported in the survey, it may include both union and non-union rates. Example: SULA2012-007 5/13/2014. SU indicates the rates are survey rates based on a weighted average calculation of rates and are not majority rates. LA indicates the State of Louisiana. 2012 is the year of survey on which these classifications and rates are based. The next number, 007 in the example, is an internal number used in producing the wage determination. 5/13/2014 indicates the survey completion date for the classifications and rates under that identifier.

Survey wage rates are not updated and remain in effect until a new survey is conducted.

## Union Average Rate Identifiers

Classification(s) listed under the UAVG identifier indicate that no single majority rate prevailed for those classifications; however, 100% of the data reported for the classifications was union data. EXAMPLE: UAVG-OH-0010 08/29/2014. UAVG indicates that the rate is a weighted union average rate. OH indicates the state. The next number, 0010 in the example, is an internal number used in producing the wage determination. 08/29/2014 indicates the survey completion date for the classifications and rates under that identifier.

A UAVG rate will be updated once a year, usually in January of each year, to reflect a weighted average of the current negotiated/CBA rate of the union locals from which the rate is based.

---

## WAGE DETERMINATION APPEALS PROCESS

1.) Has there been an initial decision in the matter? This can be:

- \* an existing published wage determination
- \* a survey underlying a wage determination
- \* a Wage and Hour Division letter setting forth a position on a wage determination matter
- \* a conformance (additional classification and rate) ruling

On survey related matters, initial contact, including requests for summaries of surveys, should be with the Wage and Hour Regional Office for the area in which the survey was conducted because those Regional Offices have responsibility for the Davis-Bacon survey program. If the response from this initial

contact is not satisfactory, then the process described in 2.) and 3.) should be followed.

With regard to any other matter not yet ripe for the formal process described here, initial contact should be with the Branch of Construction Wage Determinations. Write to:

Branch of Construction Wage Determinations  
Wage and Hour Division  
U.S. Department of Labor  
200 Constitution Avenue, N.W.  
Washington, DC 20210

2.) If the answer to the question in 1.) is yes, then an interested party (those affected by the action) can request review and reconsideration from the Wage and Hour Administrator (See 29 CFR Part 1.8 and 29 CFR Part 7). Write to:

Wage and Hour Administrator  
U.S. Department of Labor  
200 Constitution Avenue, N.W.  
Washington, DC 20210

The request should be accompanied by a full statement of the interested party's position and by any information (wage payment data, project description, area practice material, etc.) that the requestor considers relevant to the issue.

3.) If the decision of the Administrator is not favorable, an interested party may appeal directly to the Administrative Review Board (formerly the Wage Appeals Board). Write to:

Administrative Review Board  
U.S. Department of Labor  
200 Constitution Avenue, N.W.  
Washington, DC 20210

4.) All decisions by the Administrative Review Board are final.

=====

END OF GENERAL DECISION



## SECTION 01 20 00 PRICE AND PAYMENT PROCEDURES

### 01 22 00 UNIT PRICES

#### 01 22 13 Method of Measurement

##### A. General

All items of work for this contract will be measured in units as indicated on the Proposal and as noted herein. CF, cubic feet; CY, cubic yard; EA, each; LS, lump sum; LF, linear feet; SY, square yard; SF, square feet; CF, cubic feet.

#### 01 22 16 UNIT PRICE PAY ITEMS

##### 1 *Mobilization*

Payment for this item shall include project costs related to preparatory work, operations and General Requirements and includes photo-documentation of existing conditions and any necessary permits. The lump sum (LS) amount shall be paid in increments on a basis of work completed. The total amount for Mobilization may not exceed 5% of the total cost of the project.

##### 2 *Demolition*

Payment for this item shall include project costs related to removal and disposal or salvage of materials including but not limited to: existing pavement to be removed and disposed, existing trees and shrubs to be removed and disposed, existing site elements to be removed and salvaged. Measurement for this item will be made as a lump sum (LS) for all work described. Payment will be based on schedule of values and an agreed upon percentage of work complete.

##### 3 *Soil Erosion Control*

Payment for this item shall include project costs related to installation and maintenance of an approved soil erosion control system per jurisdictional and permit requirements. Inlet filter, construction fence, and silt fence placement and maintenance should be included here, as well as silt fence placement and maintenance to secure stockpiles. The lump sum (LS) amount shall be paid in increments on a basis of work 25% for installation, 5% increments per month to 75%, and 25% for completion of removal.

##### 4 *Earthwork*

Payment for this item shall include project costs related to excavation and backfilling including but not limited to: strip and stockpile existing topsoil, import additional topsoil, earthwork mass grade, provide material for clay berms, create clay berms, provide compost for rain garden soil mix, mix and place rain garden soil mix, place topsoil for landscape bed, and remove extra cut from the site. Soil erosion control and stockpile maintenance shall be included in this item. Measurement for this item will be made as a lump

sum (LS) for all work described. Payment will be based on schedule of values and an agreed-upon percentage of work complete.

5      *Stone Work*

Payment for this item shall include all labor, material and equipment necessary for the installation of stone work. Stone work includes, but is not limited to: stone wall, cobble spillways, and cobble swales specified for this site. Measurement for this item will be made as a lump sum (LS) for all work described. Payment will be based on schedule of values and an agreed upon percentage of work complete.

6      *Pavement*

Payment for this item shall include all labor, material and equipment necessary for the installation of pavement. Pavement work includes, but is not limited to: permeable paver installation, concrete walkway, concrete drive approach, concrete curb and gutter, concrete edge, concrete straight curb with outlets, and all concrete testing in accordance to City of Ann Arbor standards. Measurement for this item will be made as a lump sum (LS) for all work described. Payment will be based on schedule of values and an agreed upon percentage of work complete.

7      *Site Utilities*

Payment for this item shall include all labor, material and equipment, and management of any existing utility relocation necessary for the installation of site utilities. Utilities include, but are not limited to: PVC storm lines and storm inlet. Measurement for this item will be made as a lump sum (LS) for all work described. Payment will be based on schedule of values and an agreed upon percentage of work complete.

8      *Planting*

Payment for this item shall include all labor, material and equipment necessary for the installation of all plantings and mulch specified for this site. Included in this item is any necessary erosion control measures throughout the duration of the project. Measurement for this item will be made as a lump sum (LS) for all work described. Payment will be based on schedule of values and an agreed upon percentage of work complete.

9      *Plant Maintenance and Guarantee*

Payment for this item shall include all labor, material and equipment necessary to provide site visits according to the schedule in the specifications and maintain all plantings and prevention of erosion for the period designated. Measurement for this item will be made as a lump sum (LS) for all work described. Payment will be made on a per month basis.

*Alternate: Additional for Two-Phase Project*

Payment for this item shall include all additional labor, material, equipment, and cold weather measure costs necessary to accommodate a two-phase schedule, and is intended to cover the additional costs of

mobilization for two phases. Measurement for this item will be made as a lump sum (LS) for all work described. The lump sum (LS) amount shall be paid in increments on a basis of work completed.

**The following items shall be used to adjust the Base Bid prices if adjustment in quantities are made:**

***Erosion Control, Inlet Filter***

The contract unit price for Inlet Filter Erosion Control, shall be payment in full for all labor, materials, and equipment necessary to furnish, install, and maintain catch basin or inlet protection in accordance with the Specifications and Drawings. Maintenance work will include removal and replacement of filters as directed by the Consultant and/or Owner. Removal and disposal of the protection devices and accumulated sediment upon final completion of the project shall be considered as included in the work. The work shall also include removal of accumulated sediment from the ground surface and from the drainage structure sumps. The completed work shall be paid for at the contract unit price of each (EA).

***Erosion Control, Silt Fence***

The contract unit price for Erosion Control, Silt Fence shall be payment in full for all labor, materials, and equipment necessary to furnish, install, and maintain the silt fence in accordance with the Specifications and Drawings. Removal and disposal of the silt fence and accumulated sediment upon final completion of the project shall be considered included in the work. Placement and maintenance of stone outlet filters at low points along the silt fence line shall also be considered as included in the silt fence work. Maintenance work will include removal and replacement of silt fence and outlet filters as directed by the Consultant. Restoration of disrupted areas adjacent to silt fence shall be considered part of this item. The completed work shall be paid for at the contract unit price of linear foot (LF).

***Erosion Control Blanket***

The contract unit price for Erosion Control Blanket shall be payment in full for all labor, materials, and equipment necessary to furnish, install, and maintain the soil erosion blanket in accordance with the Specifications and Drawings, and jurisdictional requirements including maintaining adjacent flow distances. Removal and disposal of the blanket and accumulated sediment upon final completion of the project shall be considered included in the work. Maintenance work will include removal and replacement of blanket as directed by the Consultant. Restoration of disrupted areas adjacent to blanket shall be considered part of this item. The completed work shall be paid for at the contract unit price of square yard (SY).

***Construction Fence***

The contract unit price for Construction Fence shall be payment in full for all labor, materials, and equipment necessary to furnish, install, and maintain the construction fence in accordance with the Specifications and Drawings. Removal and disposal of the construction fence upon final completion of the project shall be considered included in the work. The completed work shall be paid for at the contract unit price of linear foot (LF).

***Asphalt Pavement, Remove and Dispose***

The contract unit price for Asphalt Pavement, Remove and Dispose shall be payment in full for all labor, material and equipment required to sawcut, remove, and properly dispose of the existing asphalt parking lot in accordance with the Specifications and Drawings. The contract unit price shall apply to pavement of any

thickness, and shall include bituminous and concrete. The completed work shall be paid for at the contract unit price of square yard (SY).

#### ***Concrete Pavement, Remove and Dispose***

The contract unit price for Concrete Pavement, Remove and Dispose shall be payment in full for all labor, material and equipment required to sawcut, remove, and properly dispose of the existing sidewalk, drive approach, and curb and gutter. The contract unit price shall apply to concrete of any thickness. The completed work shall be paid for at the contract unit price of square yard (SY).

#### ***Clear and Grub Existing Brush***

The contract unit price for Clear and Grub Existing Brush shall be payment in full for all labor, material, and equipment necessary to completely remove all existing landscape beds, including all plant foliage and root systems, remove and dispose of existing landscape edging, backfill the remaining holes, and to properly dispose of the materials off-site. The payment shall also include the removal of sod. Removed sod may not be used as part of proposed rain garden soil mix or existing topsoil for landscape beds. The completed work shall be paid for at the contract unit price of square yard (SY).

#### ***Remove and Dispose Existing Tree***

The contract unit price for Remove and Dispose Existing Tree shall be payment in full for all labor, material and equipment necessary to completely remove the tree, including all foliage and root systems, and to properly dispose of the materials off site. When tree removal is called for, the payment shall include removal of the stump. The completed work shall be paid for at the contract unit price of each (EA).

#### ***Remove and Dispose Existing Shrub***

The contract unit price for Remove and Dispose Existing Shrub shall be payment in full for all labor, material and equipment necessary to completely remove the shrub, including all foliage and root systems, and to properly dispose of the materials off site. When shrub removal is called for, the payment shall include removal of the stump. The completed work shall be paid for at the contract unit price of each (EA).

#### ***Strip and Stockpile Topsoil***

The contract unit price for Strip and Stockpile Topsoil shall be payment in full for all labor, material, and equipment to strip and stockpile topsoil. This includes any necessary erosion control practices to contain sediment as a result of stockpiling. The completed work shall be paid for at the contract unit price of cubic yard (CY).

#### ***Rough Grade***

The contract unit price for Rough Grade shall be payment in full for all labor, material, and equipment to rough grade the site to the subgrades defined in the Specifications and Drawings. The completed work shall be paid for at the contract unit price of cubic yard (CY).

#### ***Removal of Excess Excavated Material***

The contract unit price for Removal of Excess Excavated Material shall be payment in full for all labor, material, and equipment to remove excess soil from site and dispose of any unsuitable material. The completed work shall be paid for at the contract unit price of cubic yard (CY).

### ***Import Additional Topsoil***

The contract unit price for Import Additional Topsoil shall be payment in full for all labor, material, and equipment to import additional topsoil and fine grade in accordance with the Specifications and Drawings. The completed work shall be paid for at the contract unit price of cubic yard (CY).

### ***Clay Berm***

The contract unit price for Clay Berm shall be payment in full for all labor, material, and equipment to construct and fine grade clay berms for rain gardens in accordance with the Specifications and Drawings. The completed work shall be paid for at the contract unit price of cubic yard (CY).

### ***Cobble Swale***

The contract unit price for Cobble Swale shall be payment in full for all labor, material, and equipment to construct and fine grade cobble swales in accordance with the Specifications and Drawings. The completed work shall be paid for at the contract unit price of linear foot (LF).

### ***Cobble Spillway***

The contract unit price for Cobble Spillway shall be payment in full for all labor, material, and equipment to construct and fine grade cobble spillways in accordance with the Specifications and Drawings. The completed work shall be paid for at the contract unit price of linear foot (LF).

### ***PVC Storm Line***

The contract unit price for PVC Storm Line shall be payment in full for all labor, material, and equipment to install the PVC storm line as defined in the Specifications and Drawings. This item shall include but not limited to all excavation, base materials, installation, backfill, surface restoration, and all items necessary to complete the installation. The completed work shall be paid for at the contract unit price of linear feet (LF).

### ***Storm Inlet***

The contract unit price for Storm Inlet shall be payment in full for all labor, material, and equipment to furnish and install inlet as defined in the Specifications and Drawings. This item shall include but not limited to all base materials, installation, backfill, surface restoration, and all items necessary to complete the installation. The completed work shall be paid for at the contract unit price of each (EA).

### ***Concrete Walk***

The contract unit price for Concrete Walk shall be payment in full for all labor, material, and equipment to install walk as defined in the Specifications and Drawings. Any necessary excavation, backfill, base material, jointing, and disposal of excess materials shall also be considered as incidental to the walk construction. Payment for installation of concrete shall include all items necessary to complete the installation. The completed work shall be paid for at the contract unit price of square foot (SF).

### ***Concrete Steps***

The contract unit price for Concrete Steps shall be payment in full for all labor, material, and equipment to install concrete steps as defined in the Specifications and Drawings. Any necessary excavation, backfill, base material, and disposal of excess materials shall also be considered as incidental to the step

construction. Payment for installation of concrete steps shall include all items necessary to complete the installation. The completed work shall be paid for at the contract unit price of linear foot (LF).

### ***Concrete Drive Approach***

The contract unit price for Concrete Drive Approach shall be payment in full for all labor, material, and equipment to install the drive approach as defined in the Specifications and Drawings. Any necessary excavation, backfill, base material, jointing, and disposal of excess materials shall also be considered as incidental to the drive approach construction. Payment for installation of concrete shall include all items necessary to complete the installation. The completed work shall be paid for at the contract unit price of square foot (SF).

### ***Concrete Testing***

The contract unit price for Concrete Testing shall be payment in full for all direct fees and charges incurred by the Contractor related to concrete testing. Actual costs shall be deducted from the allowance and a credit shall be given to the Owner for the difference.

### ***Permeable Pavers***

The contract unit price for Permeable Pavers shall be payment in full for all labor, material, and equipment to install permeable pavers as defined in the Specifications and Drawings. Any necessary excavation, backfill, and disposal of excess materials shall also be considered as incidental to the permeable pavement construction. Payment for installation of permeable pavers shall include all items necessary to complete the installation. The completed work shall be paid for at the contract unit price of square foot (SF).

### ***Concrete Edge***

The contract unit price for Concrete Edge shall be payment in full for all labor, material, and equipment to install the concrete edge as defined in the Specifications and Drawings. Payment for installation of concrete edge shall include all items necessary to complete the installation. The completed work shall be paid for at the contract unit price of linear foot (LF).

### ***Concrete Straight Curb with Outlets***

The contract unit price for Concrete Straight Curb with Outlets shall be payment in full for all labor, material, and equipment to install the straight curb with outlets as defined in the Specifications and Drawings. Payment for installation of concrete straight curb with outlets shall include all items necessary to complete the installation. The completed work shall be paid for at the contract unit price of linear foot (LF).

### ***Concrete Curb and Gutter***

The contract unit price for Concrete Curb and Gutter shall be payment in full for all labor, material and equipment to install Concrete Curb and Gutter as defined in the Specifications and Drawings. Payment for installation of concrete curb and gutter shall include all items necessary to complete the installation. The completed work shall be paid for at the contract unit price of linear foot (LF).

### ***Stone Wall***

The contract unit price for Stone Wall shall be payment in full for all labor, material, and equipment to provide and install the stone wall as defined in the Specifications and Drawings. This item shall include but not limited to excavation, bedding material, compaction, placement of geotextile fabric, fine grading around

wall, clean up, and all items necessary to complete the installation. The completed work shall be paid for at the contract unit price of face foot (FF).

### ***Handrail***

The contract unit price for Handrail shall be payment in full for all labor, material, and equipment to provide and install handrails as defined in the Specifications and Drawings. This item shall include but not limited to providing the handrail, hardware, footing, and all items necessary to complete the installation. The completed work shall be paid for at the contract unit price of linear foot (LF).

### ***Stepping Stones***

The contract unit price for Stepping Stones shall be payment in full for all labor, material, and equipment to provide and install the stepping stones as defined in the Specifications and Drawings. This item shall include but not limited to excavation, bedding material, compaction, placement of stones, fine grading around stones, clean up, and all items necessary to complete the installation. The completed work shall be paid for at the contract unit price of each (EA).

### ***Rain Garden Soil Mix***

The contract unit price for Rain Garden Soil Mix shall be payment in full for all labor, material, and equipment to mix the different soil components, adequately scarify the subgrade, and place, fine grade, and integrate the rain garden soil mix as defined in the Specifications and Drawings. The completed work shall be paid for at the contract unit price of cubic yard (CY).

### ***Existing Topsoil Placement for Landscape Beds***

The contract unit price for Existing Topsoil Placement for Landscape Beds shall be payment in full for all labor, material, and equipment to place, fine grade, and integrate the landscape bed topsoil as defined in the Specifications and Drawings. The completed work shall be paid for at the contract unit price of cubic yard (CY).

### ***Tree and Shrub Planting***

The contract unit price for Tree and Shrub Planting shall be payment in full for all labor, material, and equipment necessary to install shrubs and trees as defined in the Specifications and Drawings. Payment for tree and shrub planting shall include the following (except such items for which separate prices are received on the bid form): shrubs, trees, rain garden soil mix or topsoil, mulch, water, and all items necessary to complete the installation. The completed work shall be paid for at the contract unit price of each (EA).

### ***Perennial and Native Plug Planting***

The contract unit price for Perennial and Native Plug Planting shall be payment in full for all labor, material, and equipment to provide and install native plugs and perennials as defined in the Specifications and Drawings. Payment for native plugs and perennial planting shall include the following (except such items for which separate prices are received on the bid form): native plug or perennial, rain garden soil mix, mulch, water, and all items necessary to complete the installation. The completed work shall be paid for at the contract unit price of each (EA).

### ***Mulch***

The contract unit price for Mulch shall be payment in full for all labor, material, and equipment to install mulch as shown on the Drawings, and as described in the Specifications, in the event that the Owner would like to add mulch to the Contract beyond the zones around the proposed planting. Payment for installation of mulch shall include all items necessary to complete the installation. The completed work shall be paid for at the contract unit price of cubic yard (CY).

#### ***Lawn***

The contract unit price for Lawn shall be payment in full for all labor, material, and equipment to install and establish lawn as shown on the Drawings, and as described in the Specifications. Payment for installation of lawn shall include all items necessary to complete the installation. The completed work shall be paid for at the contract unit price of square yard (SY).

#### ***Erosion Control Blanket***

The contract unit price for Erosion Control Blanket shall include all labor, materials, and equipment necessary to furnish, install, and maintain the soil erosion blanket as defined in the Specifications and Drawings and by jurisdictional requirements including maintaining adjacent flow distances. Removal and disposal of the blanket and accumulated sediment upon final completion of the project shall be considered included in the work. Maintenance work will include removal and replacement of blanket as directed by the Consultant. Restoration of disrupted areas adjacent to blanket shall be considered part of this item. The completed work shall be paid for at the contract unit price of square yard (SY).

#### ***Two-Year Plant Maintenance and Guarantee***

The contract unit price for Two-Year Plant Maintenance and Guarantee shall include all labor, material and equipment necessary to maintain and guarantee the planting for two (2) periods as defined in the Specifications. Payment for plant maintenance and guarantee shall include the following: any necessary replacement, disease and insect control, pruning, fertilizer application, mulching, removal of plant support and tags, watering, weeding, monthly reporting, spring clean-up, communication, and all other equipment necessary for a successful plant maintenance and guarantee period. The completed work shall be paid for at the contract unit price per visit (PV).

#### ***Erosion Control Permits***

Payment for this item shall include all direct fees and charges incurred by the Contractor related to permits. Actual costs shall be deducted from the allowance and a credit shall be given to the Owner for the difference.

#### ***Right-of-Way Permit***

Payment for this item shall include all direct fees and charges incurred by the Contractor related to permits. Actual costs shall be deducted from the allowance and a credit shall be given to the Owner for the difference.



# Contractor's Application For Payment No. \_\_\_\_\_

	Application Period:	Application Date:
To (Owner):	From (Contractor):	Via (Consultant)
Project:	Contract:	
Owner's Contract No.:	Contractor's Project No.:	Consultant's Project No.:

## APPLICATION FOR PAYMENT

### Change Order Summary

Approved Change Orders		
Number	Additions	Deductions
TOTALS		
NET CHANGE BY CHANGE ORDERS		

1. ORIGINAL CONTRACT PRICE .....	\$	
2. Net change by Change Orders.....	\$	
3. CURRENT CONTRACT PRICE (Line 1 ± 2) .....	\$	
4. TOTAL COMPLETED AND STORED TO DATE (Column F on Progress Estimate) .....	\$	
5. RETAINAGE:		
a. _____ % x \$ _____ Work Completed .....	\$	
b. _____ % x \$ _____ Stored Material .....	\$	
c. Total Retainage (Line 5a + Line 5b) .....	\$	
6. AMOUNT ELIGIBLE TO DATE (Line 4 - Line 5c) .....	\$	
7. LESS PREVIOUS PAYMENTS (Line 6 from prior Application) .....	\$	
8. AMOUNT DUE THIS APPLICATION .....	\$	
9. BALANCE TO FINISH, PLUS RETAINAGE (Column G on Progress Estimate + Line 5 above).....	\$	

## CONTRACTOR'S CERTIFICATION

The undersigned Contractor certifies that: (1) all previous progress payments received from Owner on account of Work done under the Contract have been applied on account to discharge Contractor's legitimate obligations incurred in connection with Work covered by prior Applications for Payment; (2) title of all Work, materials and equipment incorporated in said Work or otherwise listed in or covered by this Application for Payment will pass to Owner at time of payment free and clear of all Liens, security interests and encumbrances (except such as are covered by a Bond acceptable to Owner indemnifying Owner against any such Liens, security interest or encumbrances); and (3) all Work covered by this Application for Payment is in accordance with the Contract Documents and is not defective.

By:	Date:
-----	-------

Payment of:	\$ _____	(Line 8 or other - attach explanation of other amount)
is recommended by:	_____	_____ (Date)
	(Consultant)	
Payment of:	\$ _____	(Line 8 or other - attach explanation of other amount)
is approved by:	_____	_____ (Date)
	(Owner)	

## SECTION 31 10 00 SITE CLEARING

### PART 1 - GENERAL

#### 1.01 SUMMARY

- A. The CONTRACTOR shall furnish all labor, materials, equipment, transportation, services, and necessary appurtenant work as required to complete the work as shown on the Plans and/or as specified herein.
- B. Extent of work shall include, but not be limited to:
  - 1. Protection of persons and property
  - 2. Salvaging of existing elements to remain
  - 3. Protection of existing vegetation
  - 4. Clearing and grubbing of existing vegetation
  - 5. Stripping and stockpiling of topsoil
  - 6. Demolition, removal, and disposal of above- and below-grade improvements

#### 1.02 RELATED DOCUMENTS

- A. Attention is directed to Bidding and Contracting Requirements, Drawings, and General Provisions of the Contract, including General Conditions which are hereby made part of this section.
- B. Related Sections:
  - 1. Erosion and Sedimentation Controls 31 25 00
  - 2. Earth Moving 31 20 00
  - 3. Stone Work 31 33 00
  - 4. Planting 32 90 02

#### 1.03 PERMITS

- A. The CONTRACTOR shall secure any necessary permits, including any to work in the right-of-way.

#### 1.04 REFERENCE SPECIFICATION

- A. Materials and work covered under this Section shall be in accordance with MDOT (2012 edition), Washtenaw County, and city of Ann Arbor standard specifications for construction unless otherwise indicated. If a conflict exists between specifications, the more rigorous shall govern.

#### 1.05 QUALITY ASSURANCE

- A. The CONTRACTOR shall use adequate numbers of skilled staff who are thoroughly trained and experienced in the necessary crafts, and who are completely familiar with the specified requirements and the methods needed for proper performance of the work of this Section.

#### 1.06 REGULATORY REQUIREMENTS

- A. Conform to applicable city, county, and state law for disposal of debris at locations outside of OWNER'S property.
- B. Coordinate clearing work with utility construction.

### PART 2 - PRODUCTS

#### 2.01 CONSTRUCTION FENCE and TREE PROTECTION FENCE

- A. Fence shall be TENAX safety fence available through Construction Supply (1.800.887.6767), or approved substitution.
- B. Line, corner, terminal, gate posts, and frames shall be steel. Tie wire shall be aluminum.

#### 2.02 TOPSOIL

- A. Topsoil shall be existing topsoil that has been stripped and stockpiled. Existing topsoil shall be the top layer of soil containing the most organic matter, depth of which shall be verified by the CONSULTANT. It shall be free of any admixture of sod, subsoil, stones larger than one (1) inch, clods of hard earth, plants or roots, sticks, concrete, asphalt, or other extraneous material. It shall contain no toxic materials.
- B. Quantity: The CONTRACTOR shall be responsible for estimating the quantity of topsoil stockpiled. The CONTRACTOR is responsible to provide additional topsoil if existing topsoil does not meet the quantity required to

satisfy planting details, lawn areas, and rain gardens. The CONTRACTOR shall report any discrepancy between work on the Plans and in the Specifications to the CONSULTANT.

### **2.03 TEMPORARY SEED and MULCH or EROSION CONTROL SEED MATRIX**

- A. Seed and mulch for temporary cover shall be as described in the – EROSION AND SEDIMENTATION CONTROLS Section (31 25 00) – of these Specifications.

### **2.04 PERMANENT EROSION CONTROL**

- A. Treatment for permanent cover shall be as specified in as described in the PLANTING Section (32 90 02) under separate cover.
- B. All permanent erosion control measures shall be as specified in the – STONE WORK Section (32 15 00) of these specifications.

## **PART 3 - EXECUTION**

### **3.01 PROTECTION OF PERSONS AND PROPERTY**

- A. Construction fence shall be installed as indicated on the Plans and any area where the CONTRACTOR feels it is necessary to protect vegetation, structures, private properties, or to secure construction and hazardous areas. Additional fence beyond what is indicated on the Plans shall be done at the CONTRACTOR's expense.
- B. Construction fence shall be installed per manufacturer's standards and specifications.
- C. Protect structures, trails, sidewalks, pavements, and other facilities from damage caused by settlement, lateral movement, undermining, washout, and other hazards created by all construction operations.
- D. Use means necessary to protect persons and property as required by local and state governing authorities, including traffic warning devices when working in right-of-way.
- E. Maintain access to the site at all times. Protect benchmarks from damage or displacement.
- F. Locate, identify, and protect utilities that remain from damage. Protect trees, wetlands, plants, and features designated to remain as final landscaping.

### **3.02 PROTECTION OF EXISTING VEGETATION**

- A. Prior to commencing work, arrange an on-site meeting with the CONSULTANT to review limits of grading and subsequent vegetation protection or removal.
- B. Limits of grading are indicated on the Plans and are to be established by the CONTRACTOR.
- C. Trees indicated for relocation shall be transplanted as specified in the – TREE TRANSPLANTING Section (32 96 43) – of these Specifications.
- D. Trees not indicated to be removed or transplanted with or without tree protection should not be injured or defaced in any way. Any damage shall be replaced or repaired by a skilled tree surgeon approved by the CONSULTANT at no expense to the OWNER. Coordinate with OWNER to allow for aeration and gator bags for trees impacted by construction. Installation of construction fence shall serve as tree protection and shall not damage bark or root structure of tree.
- E. Storage of materials, parking vehicles, excess foot traffic, or stockpiling inside the drip line of trees to remain shall not be permitted.
- F. OWNER shall be justly compensated for any damage to existing trees, whether repairable or not, at the rate of \$100.00 per inch of cross-section diameter 12 inches above grade (e.g. 10-inch diameter x \$100 = \$1000).

### **3.03 UTILITY SERVICES**

- A. Protect existing utilities indicated or made known.
- B. Coordinate with utility companies and agencies as required, arrange necessary shut off, and obtain written approval before interrupting existing utilities.
- C. Provide necessary bypass connections to maintain service to occupied areas or adjacent properties.

### **3.04 CLEARING AND GRUBBING**

- A. As specified on the Plans, the CONTRACTOR shall review all tree removals with the CONSULTANT prior to any operations.
- B. Completely remove all trees, herbaceous vegetation, woody shrubs, sod, and stumps from areas as noted on the drawings and as directed by the CONSULTANT. Remove without injury to trees to remain. Do any additional

cutting or trimming only as necessary and as directed by the CONSULTANT in accordance with standard horticultural practice.

- C. Stumps shall be completely removed. The stump hole or other holes from which obstructions have been removed shall be backfilled to the adjacent grade in accordance with the – EARTH MOVING Section (31 20 00) – of these Specifications.

### 3.05 STRIP AND STOCKPILE EXISTING TOPSOIL

- A. Extent of stripping shall be areas to be occupied by a new surface, or any area where grade is to be changed and as indicated on the Plans.
- B. All topsoil shall be removed down to subsoil in such a manner as to prevent intermingling with subsoil. Grass or herbaceous material shall be removed from topsoil prior to stripping.
- C. Trees to remain shall not have topsoil stripped within the drip line unless there is grading within the drip line as shown on the Plans.
- D. The topsoil remains the property of the OWNER and shall not be removed from the site.
- E. Stockpile materials on site, review locations with OWNER; cover as required to prevent erosion and windblown dust.
- F. Stockpile in sufficient quantities to meet project schedule and requirements.
- G. All areas that are used for temporary stockpile of materials shall be restored at CONTRACTOR's expense to a condition equal to or better than prior to construction.
- H. The CONTRACTOR is responsible for using erosion control measures to prevent the erosion of soil from the stockpile.

### 3.06 DEMOLITION

- A. Completely remove and properly dispose of off-site all items referenced on the Plans and miscellaneous debris, except salvageable material, indicated on the Plans or by the OWNER. Backfill in accordance with the – EARTH MOVING Section (31 20 00) – of these Specifications.
- B. Any damage to adjacent pavement, pavement base, subbase, or utility structures caused as a result of the removal of the bituminous or concrete surface is the complete responsibility of the CONTRACTOR and shall be corrected by the CONTRACTOR at his or her expense.
- C. Carefully remove, clean, and salvage items referenced on the Plans. Items shall be delivered and stored as directed by the OWNER and CONSULTANT. Items to be salvaged will remain the property of the OWNER. Review location of stockpile and storage areas with OWNER prior to demolition.
- D. Dispose of all materials from the site in a legal manner.
- E. Do not store or permit debris to accumulate on the job site.
- F. Burning is not permitted.

**END OF SECTION**

# SECTION 31 25 00 EROSION AND SEDIMENTATION CONTROLS

## PART 1 - GENERAL

### 1.01 SUMMARY

- A. This Section includes conducting earthwork and earth change activity operations in a manner to protect waters of the state (of Michigan), storm drains, and adjacent properties from soil erosion and sedimentation.
- B. The CONTRACTOR shall furnish all labor, materials, equipment, transportation, services, and necessary appurtenant work as required to complete the work as shown on the Plans and/or as specified herein.
- C. Extent of work shall include, but not be limited to:
  - 1. Installation and maintenance of temporary soil erosion control measures

### 1.02 DEFINITIONS

- A. "Waters of the state" includes the Great Lakes and their connecting waters, lakes, ponds, and streams which may or may not be serving as a county drain as defined by the drain code; or any other body of water that has definite banks, a bed, and visible evidence of a continued flow or continued occurrence of water or wetlands regulated under Part 303 of Act 451 of Michigan compiled laws.

### 1.03 SUBMITTALS

- A. Submit product information for materials proposed for use.

### 1.04 QUALITY CONTROL

- A. Requirements of regulatory agencies: For earth changes, comply with the following:
  - 1. Part 91, Soil Erosion and Sedimentation Control (SESC) of the Natural Resource & Environmental Protection Act, 1994 PA 451, as amended (Part 91).

### 1.05 PERFORMANCE REQUIREMENTS

- A. Implement the soil erosion and sedimentation control plan including required maintenance during construction and final removal as directed in the Plans, and as needed per site conditions, and as required by site inspections by City of Ann Arbor.
- B. Control runoff, soil erosion, and sedimentation. No sediment should leave the site.
- C. Prevent wind erosion. No visible emissions (dust) should leave the site.
- D. Comply with Washtenaw County and City of Ann Arbor Sedimentation Control Procedures.

### 1.06 REFERENCES

- A. Guidebook of Best Management Practices for Michigan Watersheds ([http://www.michigan.gov/deq/0,1607,7-135-3313\\_3682\\_3714-118554--,00.html](http://www.michigan.gov/deq/0,1607,7-135-3313_3682_3714-118554--,00.html))
- B. City of Ann Arbor Standard Specifications for Construction

## PART 2 – PRODUCTS

### 2.01 SILT FENCE

- A. Silt fence shall meet MDOT Silt Fence Geotextile Standards and Specifications and is available through Price and Company, (<http://priceandcompany.com/index.html>, 1.866.960.4300).

### 2.02 INLET FILTERS

- A. Inlet filters shall be silt sack, Dandy Bag, or approved equal.

### 2.03 EROSION CONTROL/SEED MATRIX

- A. Apply erosion control seed matrix as necessary at a species rate of pounds per acre as indicated on the Drawings.
- B. Seed sources for the erosion control seed matrix for native seed mixes are available through Rhino Seed and Landscape Supply, Brighton, Michigan (1.800.482.3130); The Michigan Wildflower Farm, Portland,

Michigan (1.517.647.6010); LaFayette Home Nursery, LaFayette, Illinois, (1.309.995.3311); Prairie Nursery, Westfield, Wisconsin (1.608.296.3679), or approved substitution:

#### 2.04 EROSION CONTROL BLANKET

- A. Erosion control blanket shall be North American Green Straw Erosion Control Blanket S150 BN, 100% biodegradable, jute netted, or approved substitution.
- B. Pegs shall be of sound wood and sized per MDOT Standard Specifications, latest edition.
- C. Erosion control blanket supplier: Erosion control blanket is available through Price and Company, Inc., Wyoming, Michigan, (1.616.530.8230).

### PART 3 - EXECUTION

#### 3.01 GENERAL

- A. Where the following events result in the need for additional or modified soil erosion and sedimentation control installations to meet the objective of the referenced procedures, provide remedial installations on a timely basis:
  - 1. Unanticipated alterations to the construction schedule, or
  - 2. Unanticipated site conditions except severe weather damage such as a tornado, flood, or fire.
- B. Install temporary erosion and sedimentation control measures prior to or upon commencement to earthwork activities.

#### 3.02 SILT FENCE

- A. Install silt fence with stakes on the side down gradient from the disturbed area. Toe in six (6) inches of the fencing material. Excavated materials from toeing operation shall be placed on the upslope side of the silt fence.

#### 3.03 STOCKPILES

- A. Place stockpiles and other spoil piles away from the drainage system to minimize sediment transport. Keep as few stockpiles as possible during the course of the project. Place silt fence around any soil pile prior to storage of material. If the stockpile and/or spoil pile must remain onsite overnight, or if the weather conditions indicate the chance for precipitation:
  - 1. Cover the pile with water-repellent material to prevent erosion, or
  - 2. Install silt fencing around the base of the pile to prevent transport of sediment to the storm water system, and wet the pile as needed to prevent wind erosion, or
  - 3. Apply other control methods as appropriate to the site.
- B. If topsoil must be stored on pavement, line base of pile with tarp. Once pile has been placed, wrap edges of tarp around base and stabilize in place to prevent washing. Place additional tarp on top of pile, completely covering exposed soil.

#### 3.04 INLET FILTERS

- A. Where runoff enters the existing storm water system, protect the storm system from sedimentation.
  - 1. Temporary inlet protection must prevent the release of sediment and allow for proper drainage.
    - a. Use of burlap is not acceptable as a SESC measure.
    - b. If filter fabric is used on drains, ensure the filter fabric is placed over (not under) the storm grates to facilitate maintenance (cleaning) of the controls.
    - c. If high storm water flows are expected, use silt sacks or Dandy Bags in lieu of filter fabric for drain protection. Based on site conditions, select regular or high flow silt sacks as appropriate.

#### 3.04 EROSION CONTROL BLANKET

- A. If erosion control blanket is indicated or needed in areas where plugs are present, install erosion control blanket prior to plugging.
- B. Install erosion control blanket per manufacturer's specifications in locations indicated on Plans. In addition, erosion control blanket shall be installed where the CONTRACTOR feels it necessary to stabilize the site. Additional blanket beyond what is indicated on the Plans shall be supplied and installed at the expense of the CONTRACTOR.

- C. Begin at top of the slope by anchoring the blanket in a 6-inch deep x 6-inch wide trench. Backfill and compact the trench after staking.
- D. Roll the blankets down the slope in the direction of the water flow.
- E. The edges of parallel blankets must be staked with approximately two (2) inch overlap. When blankets must be spliced down the slope, place blankets end over end (shingle style) with approximately 6-inch overlap. Stake through overlapped area, approximately 12 inches apart.
- F. In general, stake blanket approximately one (1) stake per one (1) square foot.

### **3.05 DUST AND SEDIMENT CONTROL**

- A. Utilize a water truck as needed or as directed by CONSULTANT or OWNER for dust control.
- B. Utilize a sweeping machine to remove sediment tracked onto the pavement on a daily basis at minimum. Use sweeper more frequently as dictated by site conditions. Vacuum sweeper shall be used as directed by CONSULTANT or OWNER if sweeping machine is determined to be inadequate for removal of sediment from paved surfaces.

### **3.06 TEMPORARY SOIL EROSION CONTROL MAINTENANCE**

- A. Maintain erosion and sedimentation controls on a daily basis until the contract has been completed and accepted. Maintenance shall include:
  - 1. Repair of damaged installations,
  - 2. Replacement of lost soil erosion and sedimentation control measures, and
  - 3. Periodic removal of collected silt and sedimentation as required or directed to maintain effectiveness of the silt traps, filters, and basins.
- B. Correct non-conforming soil erosion and sedimentation control work on a timely basis within 24 hours, if waters of the State are being impacted, or within five (5) days if not impacting waters of the State.
- C. Complete permanent soil erosion control measures for all slopes, channels, ditches, or any disturbed land area within five (5) calendar days after final grading or the final earth change has been completed. Maintain temporary control measures until permanent soil erosion control measures are in place and the area is stabilized.

### **3.02 CLEAN UP**

- A. Remove temporary erosion control measures after permanent soil erosion measures are in place and the area is stabilized, unless ordered by the OWNER's representative to remain in place. Care shall be taken during removal to prevent soil erosion and sedimentation.
- B. Clean any pavement that has had stored stockpiles of soil.

**END OF SECTION**

# SECTION 31 20 00 EARTH MOVING

## PART 1 - GENERAL

### 1.01 SUMMARY

- A. Excavate, backfill, compact, and grade the site to the elevations shown on the Drawings, as specified herein, and as necessary to meet the requirements of the construction shown in the Contract Documents.
- B. Work shall include, but not be limited to:
  - 1. Excavation, backfilling, and compaction for rain garden and landscape areas
  - 2. Removal of unsuitable material
  - 3. Removal of excess fill
  - 4. Grading
  - 5. Fine grading

### 1.02 RELATED DOCUMENTS

- A. Drawings and General Provisions of the Contract, including General Conditions, apply to the work of this Section.
- B. Related Sections:
  - 1. Erosion and Sedimentation Controls 31 25 00
  - 2. Stone Work 31 33 00
  - 3. Planting 32 90 02

### 1.03 REFERENCE SPECIFICATION

- A. All materials and work done under this Section shall be in accordance with MDOT (2012 edition), Washtenaw County and city of Ann Arbor standards and specifications unless otherwise indicated. If a conflict exists between specifications, the more rigorous shall govern.

### 1.04 QUALITY ASSURANCE

- A. Use adequate numbers of skilled workmen who are thoroughly trained and experienced in the necessary crafts, and who are completely familiar with the specified requirements and the methods needed for proper performance of the work of this Section.
- B. Soil Amendments: Copies of invoices shall be provided to the CONSULTANT. Samples must be provided if requested by the CONSULTANT.

### 1.05 SUBMITTALS

- A. The testing service shall submit the following reports directly to the CONSULTANT, with copies to the OWNER and CONTRACTOR:
  - 1. Certification of soil materials, including materials acquired on- or off-site and including fill, compost, backfill, and borrow materials.

### 1.06 DEFINITIONS

- A. Subgrade: The bottom of excavation or surface of fill immediately beneath the proposed site improvements or topsoil.
- B. Fill (Backfill): Material used to bring existing or construction grades to proposed subgrade.
- C. Finish Grade: Final grade elevation indicated on the Drawings. Where not specifically noted, a uniform slope between spot elevations, except where vertical curves or rounding shall be provided at abrupt changes in slope.
- D. Trench: An excavation where the width is approximately at least twice the depth, as soil type dictates.
- E. Base: Material placed over subgrade or subbase and under surface treatment.
- F. Subbase: Material placed over subgrade and under base.
- G. Soil Materials:
  - 1. Soils classifications shall conform to ASTM D 2487 Unified Soil Classification System.



2. Satisfactory soil materials include materials classified GW, GP, GM, GC, SW, SP, SM, SC, ML, or CL. Materials shall satisfy use and specification shown on Plans, and as indicated within these Specifications. Review with CONSULTANT.
  3. Unsatisfactory soil materials include materials classified OL, MH, CH, OH, and PT.
  4. Noncohesive soil materials include materials classified GW, GP, SW, and GM and SM only when fines have a plasticity index of zero (0).
  5. Cohesive materials include materials classified GC, SC, ML, CL, MH, and CH.
- H. Maximum Unit Weight (MUW): When used as a measure of compaction or density, MUW shall be understood to mean the MUW per cubic foot as determined in accordance with ASTM D 1557 (Modified Proctor).

## **PART 2 – PRODUCTS**

### **2.01 GENERAL**

- A. Soil materials for backfill and fill at all locations shall be satisfactory site-excavation or borrow materials, unless otherwise indicated. If site-excavated material is unsatisfactory or insufficient to meet fill requirements, furnish approved borrow material at CONTRACTOR's expense. Borrow material shall be obtained from approved off-site sources.
- B. Fill material is subject to the approval of the CONSULTANT, and is that material removed from excavations or imported from off-site borrow areas, predominantly granular, non-expansive soils free from roots and other deleterious matter.

### **2.02 ORDINARY FILL / SITE EXCAVATED MATERIAL**

- A. Composition: Shall be natural inorganic soil, well-graded and free from all frozen, organic, weak, expansive or compressive materials, and contain no stone larger than two (2) inches.
- B. Character of soil shall be such that it can be spread and compacted as specified. On-site material may be used as ordinary fill provided it meets these requirements and is approved by the CONSULTANT.

### **2.03 PLASTIC WARNING TAPE**

- A. Acid and alkali-resistant polyethylene film specifically manufactured for marking and identifying underground utilities. Minimum 6-inch width, 4 mils thick, metallic core with protective jacket, detectable at 3 feet buried depth. Continuous printed inscription shall describe utility. Tape color:
  1. Electric: red
  2. Gas: yellow
  3. Telephone: orange

### **2.04 TOPSOIL**

- A. Follow requirements outlined in the – SITE CLEARING Section (31 10 00) – of these Specifications for information on existing topsoil.

### **2.05 COMPOST**

- A. Compost shall be used only from City of Ann Arbor, available from WeCare Organics (1.734.477.0334), or approved substitution.
- B. Quantity: The CONTRACTOR shall be responsible for estimating the quantity of compost necessary to obtain the specified depth of compost to be spread and integrated. The CONTRACTOR shall report any discrepancy between work on the Plans and in the Specifications to the CONSULTANT.

### **2.06 CLAY BERM**

- A. Material for clay berm shall be capable of holding water when rain garden is full.

### **2.07 RAIN GARDEN SOIL MIX**

- A. Rain garden soil mix shall be prepared on site by thoroughly mixing one (1) part existing topsoil, one (1) part compost. If there is not adequate existing topsoil, use existing soil on site.

## **PART 3 - EXECUTION**

### **3.01 BASIS OF CONTRACT**

- A. Extent of work shall be that necessary to obtain the cross-sections and elevations indicated on the Plans.

### **3.02 GENERAL EXCAVATION**

- A. Method shall be open cut or tunneling/boring where desirable for the protection of neighboring surfaces, structures, plants, workmen, and/or the public.
- B. Extent shall be as required for the proposed structures allowing ample room for construction (form work, dewatering, etc.) and inspection.
- C. Tolerance shall be within 0.10' of the proposed subgrade.
- D. Subgrade Preparation: Bottom of excavation for pavements, slabs, foundations, etc. shall be cleaned, trimmed and leveled as required for the installation immediately prior to placement of subbase, base, or foundation.
- E. Dewatering: The CONTRACTOR shall remove all water that accumulates in any excavation. The CONTRACTOR is responsible for any cost of dewatering, maintaining the dewatering until the structure can be placed, and any damage caused by the dewatering process. Groundwater and surface water which is free of contamination and sediment may be discharged to a storm drain. Drains must be protected from sediment by using filter fabric or silt sacks. However, if adequate filtration cannot be achieved at the storm drain, the water shall be discharged to the sanitary sewer after filtration.
- F. Excess excavation or disturbed subgrade that requires excavation beyond the prescribed limits shall be replaced with granular backfill or 2,000 psi concrete at the discretion of the CONSULTANT. All replacement shall be at the CONTRACTOR'S expense.
- G. Review of the subgrades by the CONSULTANT shall take place prior to placement of any base or structure. The CONTRACTOR shall provide proper advance notification.
- H. Clean excess excavated material not used for earthwork operations shall be disposed of off-site at an approved facility as directed by CONSULTANT.
- I. Hazardous Material:
  - 1. During work activities if suspect contaminated soil, groundwater, or other unknown material is encountered contact City of Ann Arbor representative (1.743.794.6410) immediately. Suspect contaminated soil may exhibit chemical or unusual odors, staining, unusual coloring, and/or contain man-made debris. Suspect contaminated groundwater may exhibit chemical or unusual odors, unusual coloring, and/or sheen.
  - 2. Immediately cease all excavation, dewatering, transport, or disturbance of the suspect material until given direction by city of Ann Arbor representative.
  - 3. Fill unauthorized excavation under foundations by extending indicated bottom elevation of concrete foundation or footing to excavation bottom.

### **3.03 EXCAVATION FOR SEWERS AND WATERMANS**

- A. Excavation shall conform to city of Ann Arbor standard specifications for construction.
- B. Exposed existing utilities shall be adequately supported during operations and given a permanent support meeting the utility OWNER's or agency's standards and such that they will not be damaged by later settlement. Any damage to existing utilities shall be repaired at the CONTRACTOR's expense to the requirements of the utility OWNER's or agency's satisfaction.

### **3.04 EXCAVATION FOR STRUCTURES**

- A. Conform to elevations and dimensions shown within a tolerance of plus or minus 0.10' and extending a sufficient distance from footings and foundations to permit placing and removal of concrete formwork, installation of services, other construction, and for inspection.
- B. In excavation for footings and foundations, take care not to disturb bottom of excavation. Excavate by hand to final grade just before concrete reinforcement is placed. Trim bottoms to required lines and grades to leave solid base to receive other work.

### **3.05 UNSUITABLE MATERIALS**

- A. Definition: Material inside building lines, under exterior walls, steps, paved areas, foundations, structures, etc. of the following characteristics:

1. Topsoil and loam
  2. Peat, organic soil, sod, wood, roots, or other matter subject to decay
  3. Soft, spongy, or compressible soil
- B. Removal of all unsuitable materials shall take place prior to construction. If unsuitable material is encountered at the required sub-grade elevation, the CONTRACTOR shall remove the unsuitable material and replace with granular fill. Excavation and backfill of unsuitable material shall be approved by the CONSULTANT. The CONTRACTOR will be paid on the basis of informative prices in the proposal form.

### 3.06 GENERAL FILLING AND BACKFILLING

- A. General: Place satisfactory soil material in layers to required subgrade elevation.
1. Under Building Slabs: Use imported granular material or satisfactory site-excavated material to subgrade elevation of slab base course.
  2. Under Trails and Pavements: Use imported granular material or satisfactory site excavated or borrow material.
  3. In Excavations: Use satisfactory site-excavated material or borrow material.
  4. Under Unpaved Areas: Use satisfactory site-excavated material or borrow material. Required subgrade of various garden areas are at a variety of depths below finished grades as indicated on Drawings and in the following:
    - a. Rain gardens: 6"
    - b. Landscape beds: 6"
- B. Ground Surface Preparations:
1. Remove all form work, debris and other deleterious material unless otherwise specified. Plow, strip, or break-up sloped surfaces steeper than one (1) vertical to four (4) horizontal so that fill material will bond with existing surface.
  2. When existing ground surface has a density less than specified under "Compaction" of this Section for particular area classification, break up ground surface, pulverize, moisture-condition to optimum moisture content, and compact to required depth and percentage of maximum density.
- C. Placement and Compaction:
1. Place backfill and fill materials in layers not more than eight (8) inches in loose depth for material compacted by heavy compaction equipment, and not more than four (4) inches in loose depth for material compacted for material compacted by hand-operated tampers.
  2. Before compaction, moisten or aerate each layer as necessary to provide optimum moisture content (-2% to +3%), or as recommended by testing laboratory. Compact each layer to required percentage of maximum unit weight for each area classification.
  3. No filling shall take place in unfavorable weather as determined by the CONSULTANT.
  4. Maintain subgrades at levels specified until scheduled for subsequent construction. Correct all settlement occurring after required rough grades are obtained and any later damage resulting therefrom.
- D. Backfill excavations as promptly as work permits, but not until completion of the following:
1. Acceptance of construction below finish grade including, where applicable, waterproofing, and perimeter insulation.
  2. Inspection, testing, approval and recording locations of underground utilities.
  3. Removal of concrete formwork
  4. Removal of shoring and bracing and backfilling of voids with satisfactory materials.
  5. Removal of trash and debris.
- E. Filling Over Rubble: It is the responsibility of the CONTRACTOR to completely choke all voids in such a manner as to stop all infiltration of fill placed above rubble, if approval to place fill over rubble is given by the CONSULTANT.
- F. The CONTRACTOR shall determine the quantities of site-excavated materials available, and quantities of material to be imported. No adjustments to the quantities will be made by the OWNER, except for backfill requirements for authorized additional excavation. The need for additional site-excavated materials must be quantified and brought to the attention of the OWNER prior to construction.

### 3.07 BACKFILLING FOR SEWERS AND WATERMAINS

- A. All backfilling for sewers and watermains shall be per city of Ann Arbor standard specifications for construction. Backfill only after pipes have been inspected, tested and locations of pipes and appurtenances have been recorded.
- B. Place bedding material to depth indicated under pipe. After pipe is installed and positioned, place remainder of bedding material in maximum six (6) inch layers to the center of the pipe.
- C. Place by hand granular backfill to a depth of one (1) foot above the pipe. Tamp firmly in layers not exceeding six (6) inches, taking care not to disturb the pipe.
- D. Under pavements, structures, etc. use granular backfill as described under "General Filling and Backfilling" of this Section.
- E. Other areas use ordinary backfill as described under "General Filling and Backfilling" of this Section.

### 3.08 PLACE WARNING TAPE

- A. Place plastic warning tape directly above utilities, 18 inches below finished grade.

### 3.09 COMPACTION

- A. General: Control soil compaction during construction providing minimum percentage of density specified for each area classification.
- B. Percentage of Maximum Unit Weight (MUW) Requirements: Compact soil to not less than the following percentages of MUW for soils which exhibit a well-defined moisture density relationship determined in accordance with ASTM D 1557 (Modified Proctor):
  - 1. Structures and Building Slab: Compact top 12 inches of subgrade and each layer of backfill or fill/base material at 95% of MUW
  - 2. Unpaved Areas: Compact top six (6) inches of subgrade and each layer of backfill or fill material at 80% MUW.
  - 3. Walks: Compact top six (6) inches of subgrade and each layer of backfill or fill/base material at 95 % of MUW.
  - 4. Pavements: Compact top 12 inches of subgrade and each layer of backfill or fill/subbase/base material at 95% of MUW.
  - 5. Utility Trench: Compact bedding layers to 95% of MUW. Compact granular backfill, 95% layers to 12 inches above pipe, compacted MUW. Remainder of trench to be backfilled at 95% of MUW under pavements, and 90% of MUW under lawn or landscaped areas.
- C. Fill in uniform horizontal layers not exceeding six (6) inches in depth, measured prior to compaction.

### 3.10 GRADING

- A. Extent shall be areas within limits of work indicated on the Plans including any adjacent transition areas.
- B. Tolerance within 0.10' of the proposed subgrade.
- C. Degree of finish shall be that which is ordinarily obtainable from a blade-grader or dozer back-blade operations.
- D. Uniformity: CONTRACTOR shall finish all grading surfaces within specified tolerance providing uniform slopes between given elevations and rounding landforms as directed by CONSULTANT.
- E. Review of subgrade landform contour by CONSULTANT is required prior to placement of topsoil or any structures.
- F. Minor changes as directed by CONSULTANT shall be at no extra cost to the OWNER.
- G. Correction of subgrade is required wherever settlement, erosion or other grade changes have occurred.

### 3.11 PLACING RAIN GARDEN SOIL MIX and FINE GRADING

- A. In rain garden planting areas, following soil ripping, soil mix shall be placed to a minimum depth of six (6) inches and incorporated into the top two (2) inches of the subgrade.
- B. Though soils in rain garden areas are to be 'roughed up,' the CONTRACTOR shall maintain adequate slopes across this area to prevent ponding of storm water.
- C. Repair rain garden soil grading as directed by the CONSULTANT so that finish grades are met.
- D. Final grades will be reviewed by the CONSULTANT prior to demobilization/completion.

### 3.12 PLACING EXISTING TOPSOIL FOR LANDSCAPE BED and FINE GRADING

- A. In landscape bed planting areas, following soil ripping, topsoil shall be placed to a minimum depth of six (6) inches and incorporated into the top two (2) inches of the subgrade.
- B. Repair landscape bed grading as directed by the CONSULTANT so that finish grades are met.
- C. Final grades will be reviewed by the CONSULTANT prior to demobilization/completion.

### 3.13 FIELD QUALITY CONTROL

- A. For each subgrade, fill, and backfill material, perform one (1) moisture-density relationship test for each 1500 cubic yards or fraction thereof of material used. Tests and analysis of material will be performed in accordance with ANSI/ASTM D1557. Minimum of one (1) test per excavated area.
- B. In-place density testing will be performed in accordance with ANSI/ASTM D1557, D1556, D2167, D2922.
- C. For areas under slabs and pavements:
  - 1. Conduct not less than one (1) in-place density test of subgrade and one (1) in-place density test of each compacted fill or backfill layer for every 1000 square feet of overlying paved area, but in no case less than three (3) tests per lift.
  - 2. After compaction of base, proofroll areas to receive pavement and slabs on grade in the presence of the testing laboratory representative. Proof roll using a four tire abreast, pneumatic tired vehicle. Each tire is to be loaded to 30,000 pounds and tires inflated to 150 psi. Provide coverage of the area to be proof rolled per the testing agencies direction. Maintain optimum moisture content during proof rolling.
- D. For Trench Backfill: Conduct not less than two (2) in-place density tests per lift.
- E. Foundation Wall Backfill: Conduct not less than two (2) in-place density tests per lift.
- F. If tests show pumping or indicate work does not meet specified requirements, remove work, replace, and retest at no cost to the OWNER.

### 3.14 DISPOSAL OF EXCESS FILL AND WASTE MATERIALS

- A. Disposal: Remove waste material, including unsatisfactory soil, trash, and debris, and legally dispose of it off the OWNER's property.
- B. Disposal: Remove and dispose all excess soil off-site in an environmentally sensitive manner.

### 3.15 GUARANTEE

- A. Settlement within a one-year period after final acceptance shall be brought to proper grade by the CONTRACTOR at no expense to the OWNER. Any surface features (i.e. pavements, structures, etc.) disturbed or damaged by settlement shall be repaired or replaced as determined by the CONSULTANT at no expense to the OWNER.

END OF SECTION

## SECTION 31 33 00 STONE WORK

### PART 1 - GENERAL

#### 1.01 SUMMARY

- A. The CONTRACTOR shall furnish all labor, materials, equipment, transportation, services, and necessary appurtenant work as required to complete the work as shown on the Plans and/or as specified herein.
- B. Extent of work shall include, but not be limited to:
  - 1. Cobble spillways
  - 2. Cobble inlets
  - 3. Stone walls
  - 4. Stepping stones

#### 1.02 RELATED DOCUMENTS

- A. Attention is directed to Bidding and Contracting requirements, Drawings, and General Provisions of the Contract, including General Conditions, which are hereby made part of this Section.
- B. Related Sections:
  - 1. Earth Moving 31 20 00

#### 1.03 REFERENCE SPECIFICATION

- A. Materials and work covered under this Section shall be in accordance with MDOT (2012 edition), Washtenaw County, and city of Ann Arbor standard specifications for construction unless otherwise indicated. If a conflict exists between specifications, the more rigorous shall govern.

#### 1.04 SUBMITTALS

- A. CONTRACTOR to provide manufacturer's product data, including installation instructions, certifying that each material item complies with (or exceeds) specified requirements.
- B. The CONTRACTOR shall provide full scale samples of each stone type indicated, representative of all variations to be expected in the finished installation.

#### 1.05 QUALITY ASSURANCE

- A. Stone work shall be carried out by CONTRACTOR and their employees who are thoroughly experienced and skilled in the necessary crafts, and who are completely familiar with the specified requirements and methods needed for proper performance of the work of this Section.
  - 1. Single Source Responsibility: Provide cobble from same source.
  - 2. The CONTRACTOR shall have a pre-construction conference with the CONSULTANT to review design intent and limits.

#### 1.06 DELIVERY, STORAGE AND HANDLING

- A. Deliver, store, and handle materials in a manner to prevent damage and deterioration to materials or existing site improvements.

### PART 2 – PRODUCTS

#### 2.01 ACCEPTABLE SOURCES:

- A. All materials used on the job shall be the source's highest quality product for each usage specified.
- B. Colors to be selected by CONSULTANT and/or OWNER.

#### 2.02 STONE

- A. Stone for cobble spillways to be 4-8" native cobble and chocked with MDOT 34R bedding gravel and 1-2" stone for chocking.
- B. Stone for cobble swales to be 6-8" native cobble with MDOT 6AA crushed limestone base.
- C. Stone for stone wall shall be 12-24" native field stone with MDOT 6A drainage stone and MDOT 21AA bedding pad.

- D. Stone for stepping stones shall be high-density limestone, available from the Rock Shoppe (1.734.455.5560).

### 2.03 GEOTEXTILE SEPARATOR

- A. Geotextile separator shall be 4-ounce needlepunch polypropylene non-woven, as supplied by Price and Company (1.866.960.4300), or approved substitution.

## PART 3 - EXECUTION

### 3.01 EXCAVATION, SUBGRADE, AND BACKFILL

- A. Excavation, subgrade, and backfill shall conform to the – EARTH MOVING Section (31 20 00) – of these Specifications (unless otherwise noted).
- B. Temporary excavated slopes should be no greater than a one-horizontal to one-vertical angle, or as required by OSHA guidelines.
- C. Temporary excavated slopes should be no greater than a one-horizontal to one-vertical angle, or as required by OSHA guidelines.
- D. CONTRACTOR shall ensure temporary excavations are stable and provide excavation support if needed.
- E. If site and soil conditions or loadings are different than in the Drawings and the design parameters, the CONTRACTOR must contact CONSULTANT prior to proceeding with the construction.

### 3.02 COBBLE SPILLWAYS

- A. Strip vegetation and organic soil from base of spillway to six inches below the bottom of rain garden to expose suitable inorganic subgrade.
- B. CONTRACTOR shall slope site grades to direct surface runoff away at end of each day to avoid water damage to the spillway while under construction.
- C. Any surface drainage features, finish grading, erosion control, or turf shall be installed immediately after cobble spillways are completed.

### 3.03 STONE WORK

- A. All stone work shall conform to the design and details as shown on the Drawings (unless otherwise noted).
- B. CONTRACTOR shall field verify and/or correct any dimensions on the Drawings.
- C. Finish grades shall not vary from those specified on the Drawings by more than 0.10 inch.

### 3.04 GEOTEXTILE SEPARATOR

- A. Install per manufacturer's standards and specifications.

### 3.05 BACKFILLING AND CLEANING OPERATIONS

- A. Stone (and all other excess material) shall be removed and properly disposed of off the OWNER's property.
- B. Backfill as described in the – EARTH MOVING Section (31 20 00) – of these Specifications.

### 3.06 GUARANTEE

- A. Any movement (i.e. upheaval or settlement) within a one-year period after final acceptance shall be brought to proper grade by the CONTRACTOR at no expense to the OWNER.
- B. Any non-secure or disturbed stone shall be repaired or replaced as determined by the CONSULTANT at no expense to the OWNER.

END OF SECTION

# SECTION 32 13 13 CONCRETE PAVEMENT

## PART 1 - GENERAL

### 1.01 SUMMARY

- A. Scope: Provide all labor and materials for concrete work where shown on the Drawings as specified herein, and as needed for complete and proper installation.
- B. Extent of work shall include, but not be limited to:
  - 1. Concrete walkways
  - 2. Concrete edge
  - 3. Concrete straight curb with outlets

### 1.02 RELATED DOCUMENTS

- A. Attention is directed to Bidding and Contracting Requirements, Drawings, and General Provisions of the Contract, including General Conditions which are hereby made part of this section.
- B. Related Sections:
  - 1. Earth Moving 31 20 00

### 1.03 PERMITS<sup>622</sup>

- A. The CONTRACTOR shall secure any necessary permits, including any to work in the right-of-way.

### 1.04 REFERENCE SPECIFICATION

- A. Materials and work covered under this Section shall be in accordance with MDOT (2012 edition), Washtenaw County, and city of Ann Arbor standard specifications for construction unless otherwise indicated. If a conflict exists between specifications, the more rigorous shall govern.

### 1.05 QUALITY CONTROL

- A. Contractor shall follow all City of Ann Arbor standards for inspection and testing for concrete pavement. Refer to Section 1E of the City of Ann Arbor Standard Specifications for inspection protocol. Contact the City of Ann Arbor Engineering Department: 734-794-6410.
- B. Obtain materials from same source throughout to ensure consistency of finished work.
- C. Ready Mix Ticket copy shall be supplied to CONSULTANT.
- D. The OWNER will employ a testing laboratory to perform materials evaluation of concrete delivered to and placed at the site. The testing firm will take cylinders and perform slump and air entrainment tests in accordance with ACI 301. The CONTRACTOR shall give the testing service adequate advance notice of the concrete schedule so the testing service will have adequate time to perform tests and will not cause a delay in work.
- E. Installation of concrete paving, including any special architectural concrete work, shall be carried out by contractors and their employees who are thoroughly experienced and skilled in the necessary crafts and who are completely familiar with the specified requirements and methods needed for proper performance of the work of this Section. The contractor shall have a minimum of five (5) years documented experience in comparable work.

### 1.06 SUBMITTALS

- A. Laboratory Test Reports: The testing agency shall submit three (3) copies of laboratory test reports for concrete materials, for mix design tests and for results of field quality control testing the CONSULTANT and the OWNER, and the CONTRACTOR on the same day tests are made.
- B. Written report of proposed mix shall be supplied to CONSULTANT 15 days prior to pouring. Pouring shall not take place unless CONTRACTOR has received notice that mix has been reviewed.
- C. Submit product data on joint filler, admixtures, and curing compounds.

## PART 2 - PRODUCTS

### 2.01 CONCRETE

- A. Mixture shall be MDOT P1, Table 601-2. Mixture shall meet Class A requirements of the City of Ann Arbor Standard Specifications for Construction.



- B. Cement shall be Air-Entraining Portland Cement Type 1A, meeting ASTM Designation C150. Air entrainment to be between five (5) percent to (7) percent.
- C. Coarse aggregate shall be MDOT 6AA, natural aggregate. Limestone not permitted.
- D. Fine aggregate shall be MDOT 2NS, natural washed sand.
- E. Water shall be clean and free from oil, acid, alkali, organic matter, or other deleterious substances.
- F. Strength requirement is a minimum compressive strength of 3,500 psi at age of 28 days.
- G. Maximum slump shall be two (2) to four (4) inches for pads and three (3) inches for vertical walls, footings, abutments, etc.
- H. Water added at job site shall be done only with the approval of the CONSULTANT or their testing agency. The CONTRACTOR assumes all responsibility for the mix if water is added and the maximum slump is exceeded, causing the load to be rejected. The water-cement ratio, by weight, may not exceed .45 for air-entrained concrete.
- I. Fly ash and calcium chloride will not be permitted in concrete.

## 2.02 RELATED MATERIALS

- A. Expansion joint material shall be pre-molded expansion joint filler "Fibre Expansion Joint Material" meeting ASTM designation D-1751-65 and shall be ½ inch thick.
- B. Membrane Forming Curing Compound:
  - 1. ASTM C 309, Type 2 Class B per MDOT Section 903.05.

## 2.03 FORMS

- A. For general concrete pavement, material shall be wood or metal, straight and free of distortion and warps, and of adequate strength to resist springing during the process of placing the concrete.
- B. Forms shall allow for full depth of concrete shown on the Plans.

## 2.04 REINFORCING STEEL

- A. Material shall be deformed steel bars conforming to the requirements of ASTM designation A305.

## 2.05 WIRE FABRIC

- A. Material shall be Welded Wire Fabric 6 x 6 W 2.9 x W 2.9.

# PART 3 - EXECUTION

## 3.01 SUBGRADE, SUBBASE, AND BASE PREPARATION: PER EARTH MOVING SECTION

- A. Wet down subgrade or base and adjacent concrete prior to concrete placement.
- B. Concrete shall be placed on minimum four (4) inch thick base of Class II granular material.

## 3.02 FORMWORK

- A. Forms shall be set firmly on the subgrade or base, joined neatly and tightly and staked securely to line and grade. The forms shall be for the full specified depth of the structure or pad.
- B. Formwork shall be measured and inspected by City of Ann Arbor staff and will require advance notice. Refer to Section 1E of the City of Ann Arbor Standard Specifications for details.
- B. Oil or wet all forms prior to concrete placement. Remove all soil and concrete from previously used forms.
- C. Ties and spreaders are subject to review by CONSULTANT. Ties shall not project through the finished concrete, remaining one (1) inch or more below face of concrete. No wood spreaders shall be allowed to remain in the concrete.

## 3.03 REINFORCING STEEL

- A. Placement shall be accurate according to Drawings. Steel shall be securely held in place before and during the placing of the concrete. When placed in forms, steel shall be free from dirt, rust, mill scale, paint, oil, or other foreign material. If concrete is not poured soon after setting steel, formwork shall be reviewed again prior to pouring.

## 3.04 WIRE FABRIC

- A. Placement shall be accurate according to Drawings. Fabric shall be securely held in place before and during the placing of the concrete. When placed in forms, fabric shall be free from dirt, rust, mill scale, paint, oil, or other

foreign material. If concrete is not poured soon after setting fabric, formwork shall be reviewed again prior to pouring.

### 3.05 CONCRETE PAVEMENT

- A. Prior to placement, all forms, base, and subgrade shall have been reviewed by the CONSULTANT and the CITY to ensure compliance with grades.
- B. Placement shall be in a single course for the full specified depth. The concrete shall be deposited in a continuous operation completing individual sections to the required depth and width. The concrete shall be poured to the top of the forms and shall be struck off the finished grade. The concrete shall be thoroughly spaded and or vibrated along the faces of the forms and adjacent to the transverse or longitudinal expansion joint forms. The end of each day's pour shall end with an expansion joint.
- C. Finish grades shall not vary from those specified on the Drawings by more than 0.10 inch.
- D. All city sidewalks & access walks shall be five (5) feet wide and four (4) inches thick except when crossing concrete drive approaches. For other concrete pavement, minimum depth shall be as indicated on Drawings.
- E. Temperature: Concrete delivered when outdoor temperatures are lower than 40°F shall arrive at the work having a temperature of not less than 60°F or greater than 90°F. If, in the opinion of the CONSULTANT, during the process of the work or within 36 hours of pouring, the temperature is or may drop to 35°F, the concrete shall be heated and precautions taken to protect the work from freezing for at least five (5) days after placing. Concrete pavement may not be placed at any time when the temperature is below 35°F.

### 3.06 STRUCTURAL CONCRETE

- A. Placement shall conform to MDOT Specifications 706, 'Structural Concrete Construction' and to the Section CAST-IN-PLACE CONCRETE (03 30 00).

### 3.07 FINISHING CONCRETE

- A. Proper grade shall be achieved by a strike board, then worked with a float in a manner that will thoroughly compact it and provide a surface free from depression or irregularities of any kind.
- B. Surface shall be steel troweled, but excessive working shall be avoided. Dusting of dry cement on the surface to dry excessive moisture will not be permitted, nor will the sprinkling of water on the surface to facilitate finishing be permitted.
- C. Unless specified otherwise brush surface after jointing and troweling is completed. Brushing shall be transverse, taking place after the concrete has hardened sufficiently to retain the brush marks but prior to the initial set. The surface shall receive a light broom finish, and shall be in straight, parallel lines that are neat in appearance.
- D. Round or radius all exposed exterior corners.
- E. Edges of curb, the back top edge of the curb, and all transverse joints and planes of weakness shall be rounded with an approved finish tool, having a radius of 1/8 inches. The face of the curb, at the top and bottom, shall be rounded with approved tools having the radii on the Drawings.

### 3.08 EXPANSION JOINTS

- A. Transverse expansion joints shall be constructed at right angles to the centerline of the pad or as indicated on the Drawings.
- B. Longitudinal expansion joints will be required along curbs and around concrete footings. They shall be parallel to the centerline of the footing.
- C. Expansion joints shall be made by the use of premolded fibre expansion joint filler, precut to the required length. Fibre filler shall be placed ½ inch below the top of the walk and extend ½ inch below the bottom of the walk. The joints shall be perpendicular to the surface of the pad and shall be formed straight.
- D. Do not permit reinforcement to extend continuously through any expansion joint.
- E. In paving, locate expansion joints where indicated on Drawings, filled to full depth with expansion joint material.
- F. In curbs, locate ½ inch thick joint at the beginning and end of curves, and at 50'-0" centers elsewhere.

### 3.09 CONTROL JOINTS

- A. Concrete pad shall be divided transversely into sections by control joints. The distance between two successive joints in paving shall be indicated on the Drawings or as directed by the CONSULTANT.
- B. In curbs, place scored joints at five (5) feet on center, or as called for on Drawings.

- C. Control joints shall be sawcut or tooled as indicated on the Drawings.
- D. Sawcut joints shall be 1/8 inch wide and a minimum of one (1) inch in depth.
- E. Placement of tooled joints shall be produced by scoring the concrete with a "Cement Groover," after floating to a depth of not less than 3/4 inches. The scored joints shall be round edges having a radius of 1/8 inch. The width of the scored joint shall be 1/4 inch. The depth of the score joint shall be 1/4 the depth of the concrete section.
- F. The scored joint shall be finished smooth and true to line. Any concrete pavement with joints improperly placed or not true to line shall be replaced by the CONTRACTOR at no cost to the OWNER.

### **3.10 RETEMPERING**

- A. Retempering of concrete which has partially hardened, that is, remixing with or without additional materials or water, shall not be permitted.

### **3.11 CURING COMPOUND**

- A. Application shall be as per manufacturer's recommendations.

### **3.12 CONCRETE PROTECTION**

- A. Protect all concrete work for a period of at least 24 hours or until concrete is sufficiently cured to prevent damage of any kind including from pedestrian traffic, writing, footsteps, etc. Concrete work shall also be protected from vehicular traffic for a period of not less than five (5) days unless at the CONTRACTOR's option and own expense a higher cement ratio concrete is used.
- B. Damaged concrete shall be the responsibility of the CONTRACTOR. All damaged areas up to the nearest expansion joint or scored joint shall be replaced.

### **3.13 BACKFILLING AND CLEANING OPERATIONS**

- A. Forms, stakes, and all other excess material shall be removed and properly disposed of off the OWNER's property.
- B. Backfill after removal of the forms as described in the - EARTH MOVING Section (31 20 00) – of these Specifications.

### **3.14 FIELD QUALITY CONTROL**

- A. Tests and Frequency:
  - 1. Composite Sampling, and Making and Curing of Specimens: ASTM C 172 and ASTM C 31. Take samples at point of discharge.
  - 2. Slump: ASTM C 143. One test per batch.
  - 3. Air Content of Normal Weight Concrete: ASTM C 173 or ASTM C 231. One test per strength test performed on air entrained concrete.
  - 4. Concrete Temperature: Test each time a set of strength test specimens is made. Test hourly when air temperature is 40° F or below.
  - 5. Compressive Strength Tests: ASTM C 39. Mold and cure one set of four (4) standard cylinders for each compressive test required. Obtain samples on a statistically sound, random basis. Minimum frequency shall be one (1) set per 100 cubic yards, or one (1) set per 3500 square feet of slab for each day's pour of each concrete class. When less than these amounts are placed in a day, the CONSULTANT may at the CONSULTANT's option waive testing of specimens if adequate evidence of satisfactory strength is provided.
- B. Test Results: The testing agency shall report test result in writing to the CONSULTANT, and the CONTRACTOR, within 24 hours of the test. Test reports shall contain project name, date, air temperature, time of pour, location of batch in completed work, type and class of concrete, and test samples taken as required by respective ASTM test methods.
- C. The testing agency shall make additional tests as directed by the CONSULTANT when test results indicate that specified strength and other concrete characteristics have not been attained. The cost of additional testing, and/or the removal and replacement of unacceptable concrete will be borne by the CONTRACTOR.

**END OF SECTION**



## SECTION 32 14 13.19

### PERMEABLE CONCRETE PAVER MATERIALS

#### PART 1 GENERAL

##### 1.01 SUMMARY

- A. Section includes the following:
  - 1. Permeable Concrete Pavers
  - 2. Permeable Joint Opening Aggregate
  - 3. Permeable Joint Aggregate Type 1
  - 4. Permeable Joint Aggregate Type 2
  - 5. Permeable Setting Bed Aggregate (Open-graded)
  - 6. Permeable Base Aggregate (Open-graded)
  - 7. Permeable Subbase Aggregate (Open-graded)

##### 1.02 REFERENCES

Note: Design street, industrial, port and airport pavement thicknesses in consultation with a qualified civil engineer, in accordance with established flexible pavement design procedures, LOCKPAVE® software, and in accordance with Interlocking Concrete Pavement Institute Technical Bulletins. Sample construction detail drawings are available from Unilock®. This specification may require modifications.

- A. ASTM International, latest edition:
  - 1. C 29 Bulk Density and Voids in Aggregate Materials.
  - 2. C 33, Standard Specification for Concrete Aggregates.
  - 3. C 67, Standard Test Methods for Sampling and Testing Brick and Structural Clay Tile, Section 8, Freezing and Thawing.
  - 4. C 136, Standard Test Method for Sieve Analysis of Fine and Coarse Aggregates.
  - 5. C 140, Standard Test Methods for Sampling and Testing Concrete Masonry Units and Related Units.
  - 6. C 144 Standard Specifications for Aggregate for Masonry Mortar.
  - 7. D 448, Standard Classification for Sizes of Aggregate for Road and Bridge Construction.
  - 8. C 936, Standard Specification for Solid Concrete Interlocking Paving Units.
  - 9. C 979, Standard Specification for Pigments for Integrally Colored Concrete.
  - 10. D 698 Test Methods for Moisture Density Relations of Soil and Soil Aggregate Mixtures Using a 5.5 lb (24.4 N) Rammer and 12 in. (305 mm) drop.
  - 11. D 1557 Test Methods for Moisture Density Relations of Soil and Soil Aggregate Mixtures Using a 10-lb (44.5 N) Rammer and 18 in. (457 mm) drop.
  - 12. C1645 Standard Test Method for Freeze-thaw and De-icing Salt Durability of Solid Concrete Interlocking Paving Units
  - 13. D 1883, Test Method for California Bearing Ratio of Laboratory-Compacted Soils.
  - 14. D 2940 Graded Aggregate Material for Bases or Subbases for Highways or Airports.
  - 15. D 4254, Standard Test Methods for Minimum Index Density and Unit Weight of Soils and Calculation of Relative Density.
  - 16. D 5261, Standard Test Method for Measuring Mass per Unit Area of Geotextiles
  - 17. D 4632, Standard Test Method for Grab Breaking Load and Elongation of Geotextiles
  - 18. D 4533, Standard Test Method for Index Trapezoidal Tearing Strength of Geotextiles
  - 19. D 4833, Standard Test Method for Index Puncture Resistance of Geotextiles, Geomembranes and Related Products

20. D 4491, Standard Test Method for Water Permeability of Geotextiles by Permittivity
21. D 4751, Standard Test Method for Determining Apparent Opening Size of a Geotextile
22. D 4354, Standard Practice for Sampling of Geosynthetics for Testing
23. D 4759, Standard Practice for Determining the Specifications Conformance of Geosynthetics

Note: In order to determine the latest version of the listed specifications and standards, please consult the ASTM web page ([www.astm.com](http://www.astm.com))

### 1.03 SUBMITTALS

- A. Permeable Concrete Pavers:
  1. Samples for verification: Three representative full-size samples of each paver type, thickness, color and finish that indicate the range of color variation and texture expected upon project completion.
  2. Accepted samples become the standard of acceptance for the product produced.
  4. Manufacturer's catalog product data, installation instructions, and material safety data sheets for the safe handling of the specified materials and products.
- B. Permeable Joint Opening Aggregate:
  1. Provide three representative one pound samples in containers of aggregate materials that indicate the range of color variation and texture expected upon project completion.
- C. Permeable Setting Bed, Base and Subbase Aggregate:
  1. Provide three representative one pound samples in containers.
  2. Provide gradation and source.
- D. Paving Installation Contractor:
  1. Job references from a minimum of three projects similar in size and complexity. Provide Owner/Client/General Contractor names, postal address, phone, fax, and email address.

### 1.04 QUALITY ASSURANCE

- A. Utilize a Manufacturer having at least ten years of experience manufacturing interlocking concrete pavers on projects of similar nature or project size.
- B. Source Limitations:
  1. Obtain Permeable Concrete Pavers from one source location with the resources to provide products of consistent quality in appearance and physical properties.
  2. Obtain Permeable Joint Opening Aggregate from one source with the resources to provide materials and products of consistent quality in appearance and physical properties.
- C. Paving Contractor Qualifications:
  1. Utilize an installer having successfully completed concrete paver installation similar in design, material, and extent indicated on this project.
- D. Mockups:
  1. Install a 5 ft x 5 ft paver area.
  2. Use this area to determine joint sizes, lines, laying pattern(s) and levelness. This area will serve as the standard by which the workmanship will be judged.
  3. Subject to acceptance by owner, mock-up may be retained as part of finished work.
  4. If mock-up is not retained, haul offsite and dispose legally.

### 1.05 DELIVERY, STORAGE & HANDLING

- A. Deliver Permeable Concrete Pavers in manufacturer's original, unopened and undamaged container packaging with identification labels intact.
  1. Coordinate delivery and paving schedule to minimize interference with normal use of streets and sidewalks adjacent to paver installation.
  2. Deliver concrete pavers to the site in steel banded, plastic banded or plastic wrapped packaging capable of transfer by forklift or clamp lift.

3. Unload pavers at job site in such a manner that no damage occurs to the product or adjacent surfaces.
  - B. Store and protect materials free from mud, dirt and other foreign materials.
- 1.06 PROJECT/SITE CONDITIONS
- A. Environmental Requirements:
    1. Install permeable pavers only on unfrozen permeable setting bed aggregate materials.
    2. Install permeable setting bed only on unfrozen permeable base and subbase aggregates.
    3. Install permeable base or subbase aggregates only over unfrozen subgrade.
- 1.07 PERMEABLE CONCRETE PAVER OVERAGE AND ATTIC STOCK
- A. Provide a minimum of 5% additional material for overage to be used during construction.
  - B. Furnish 100 square feet of each product and size used to owner for maintenance and repair. Furnish Permeable Concrete Pavers from the same production run as installed materials.
  - C. Manufacture to supply maintenance and reinstatement manuals for Permeable Concrete Paver units.

## PART 2 PRODUCTS

### 2.01 PERMEABLE CONCRETE PAVERS

- A. Basis-of-Design Product: The permeable concrete paver shapes are based on:
  1. Unilock:
    - a. Eco-Optiloc
  2. As manufactured by:  
Unilock Michigan  
12591 Emerson Drive  
Brighton, MI 48116  
Contact: Adam DeLamielleure 248-437-7037
  3. Substitutions: No substitutions permitted.
- B. Product requirements:
  1. Permeable Paver Type: Unilock Eco-Optiloc
    - a. Color: Standard
    - b. Finish: Standard
    - c. Edge: Chamfer - 3 mm bevel
    - d. Size: Manufacture the sizes indicated with a maximum tolerance of plus or minus 1/16 in all directions.
      1. L-shape

Note: Imperial dimensions are nominal equivalents to the metric dimensions.
- C. Provide pavers meeting the minimum material and physical properties set forth in ASTM C 936, Standard Specification for Interlocking Concrete Paving Units. Efflorescence is not a cause for rejection.
  1. Average compressive strength 8000 psi (55MPa) with no individual unit under 7,200 psi (50 MPa).
  2. Average absorption of 5% with no unit greater than 7% when tested according to ASTM C 140.
  3. Resistance to 50 freeze-thaw cycles, when tested according to ASTM C1645, with no breakage greater than 1.0% loss in dry weight of any individual unit. Conduct this test method not more than 12 months prior to delivery of units.
- D. Accept only pigments in concrete pavers conforming to ASTM C 979.  
Note: ACI Report No. 212.3R provides guidance on the use of pigments.
- E. Maximum allowable breakage of product is 5%.

2.02 PERMEABLE JOINT OPENING AGGREGATE

- A. Provide Permeable Joint Opening Aggregate materials conforming to ASTM C 33 and gradation requirements of ASTM D 448 No. 8 as shown in Table 1.

**TABLE 1 - ECO-OPTILOC  
 PERMEABLE JOINT OPENING AGGREGATE  
 GRADATION REQUIREMENTS  
 (CRUSHED LIMESTONE)**

ASTM No. 8	
Sieve Size	Percent Passing
1/2 in (12.5 mm)	100
3/8 in (9.5 mm)	85 to 100
No. 4 (4.75 mm)	10 to 30
No. 8 (2.36 mm)	0 to 10
No. 16 (1.18 mm)	0 to 5

2.03 PERMEABLE SETTING BED AGGREGATE

- A. Provide Permeable Setting Bed Aggregate materials conforming to ASTM C 33 and gradation requirements of ASTM D 448 No. 8 as presented in Table 3.

**TABLE 3  
 PERMEABLE SETTING BED AGGREGATE  
 GRADATION REQUIREMENTS**

ASTM No. 8	
Sieve Size	Percent Passing
1/2 in (12.5 mm)	100
3/8 in (9.5 mm)	85 to 100
No. 4 (4.75 mm)	10 to 30
No. 8 (2.36 mm)	0 to 10
No. 16 (1.18 mm)	0 to 5

2.04 PERMEABLE BASE AGGREGATE

- A. Provide Permeable Base Aggregate materials conforming to ASTM C 33 and gradation requirements of ASTM D 448 No. 57 as presented in Table 4.

**TABLE 4  
 PERMEABLE BASE AGGREGATE  
 GRADATION REQUIREMENTS**

ASTM No. 57	
Sieve Size	Percent Passing
1-1/2 in (37.5 mm)	100
1 in (25 mm)	95 to 100
1/2 in (12.5 mm)	25 to 60
No. 4 (4.75 mm)	0 to 10
No. 8 (2.36 mm)	0 to 5



2.05 PERMEABLE SUBBASE AGGREGATE

- A. Provide Permeable Subbase Aggregate materials conforming to ASTM C 33 and gradation requirements of ASTM D 448 No. 2 as presented in Table 5.

**TABLE 5  
PERMEABLE SUBBASE AGGREGATE  
GRADATION REQUIREMENTS**

ASTM No. 2	
Sieve Size	Percent Passing
3 in (75 mm)	100
2-1/2 in (63 mm)	90 to 100
2 in (50 mm)	35 to 70
1-1/2 in (37.5 mm)	0 to 15
3/4 (19 mm)	0 to 5

Note: For all aggregates, provide washed, clean, have zero plasticity, free from deleterious or foreign matter, crushed, angular rock and contain no No. 200 sieve size aggregate materials used in the construction of permeable pavement. Aggregate materials serve as the structural load bearing platform of the pavement as well as a temporary receptor for the infiltrated water that is collected through the openings in the pavement's surface.

2.06 GEOTEXTILE

- A. Provide Geotextile material conforming to the following performance characteristics, measured per the test methods referenced:
  - 1. 4 oz., nonwoven needle punched geotextile composed of 100% polypropylene staple fibers that are inert to biological degradation and resists naturally encountered chemicals, alkalis, and acids.
  - 2. Grab Tensile Strength: ASTM D 4632: 115 lbs.
  - 3. Grab Tensile Elongation: ASTM D 4632: 50%
  - 4. Trapezoidal Tear: ASTM D4533: 50 lbs.
  - 5. Puncture: ASTM D4833: 65 lbs.
  - 6. Apparent Opening Size: ASTM D 4751: 0.212 mm, 70 U.S. Sieve
  - 7. Permittivity: ASTM D 4491: 2.0 sec -1
  - 8. Flow Rate: ASTM D 4491: 140 gal/min/s.f.
- B. As supplied by Unilock, Brighton, Michigan  
Contact: Adam DeLamielleure (1.248.437.7037)

2.07 EDGE RESTRAINTS

- A. Concrete Edge as indicated.

**PART 3 EXECUTION**

3.01 EXAMINATION

- A. Examine areas indicated to receive paving for compliance with requirements for installation tolerances and other conditions affecting performance for the following items before placing the Permeable Concrete Pavers.
  - 1. Verify that subgrade preparation, compacted density and elevations conform to specified requirements.
  - 2. Verify that Geotextiles, if applicable, have been placed according to drawings and specifications.

3. Verify that Permeable Base and Subbase Aggregate materials, thickness, compacted density, surface tolerances and elevations conform to specified requirements.
4. Verify location, type, and elevations of edge restraints, concrete collars around utility structures, and drainage inlets.
- B. Proceed with installation only after unsatisfactory conditions have been corrected.
  1. Beginning of bedding sand and paver installation signifies acceptance of base and edge restraints.

### 3.02 PREPARATION

- A. Verify that the subgrade soil is free from standing water.
- B. Stockpile Permeable Setting Bed, Joint, Base and Subbase Aggregate materials such that they are free from standing water, uniformly graded, free of any organic material or sediment, debris, and ready for placement.
- C. Remove any excess thickness of soil applied over the excavated soil subgrade to trap sediment from adjacent construction activities before placing the Geotextile and Permeable Subbase Aggregate materials.
- D. Keep area where pavement is to be constructed free from sediment during entire job. Remove and replace all Geotextile, Permeable Joint, Setting Bed, Base and Subbase Aggregate materials contaminated with sediment with clean materials.
- E. Complete all subdrainage of underground services within the pavement area in conjunction with subgrade preparation and before the commencement of Permeable Subbase Aggregate construction.
- F. Prevent damage to underdrain pipes, overflow pipes, observation wells, or inlets and other drainage appurtenances during installation. Report all damage immediately.
- G. Compact soil subgrade uniformly to at least 90 percent of Standard Proctor Density per ASTM D 698 for pedestrian areas. Compact soil subgrade uniformly to at least 95 percent Modified Proctor per ASTM D 1557 for vehicular areas.
- H. Proof-roll prepared subgrade according to requirements in Division 31 Section "Earth Moving" to identify soft pockets and areas of excess yielding. Excavate soft spots, unsatisfactory soils, and areas of excessive pumping or rutting and replace with compacted backfill or fill as directed.

Note: Base compaction and proof-rolling of the subgrade soil on the recommendations of the Design Engineer. Request the Architect/Engineer to inspect subgrade preparations, elevations and conduct density tests for conformance to specifications.

### 3.03 INSTALLATION

- A. EDGE RESTRAINTS
  1. Provide edge restraints as indicated.
    - a. Install job-built concrete edge restraints to comply with requirements in Section 32 13 13 Concrete Paving.
    - b. Provide concrete edge restraint along the perimeter of all paving as specified. Install the face of the concrete edge restraint, where it abuts pavers vertical down to the subbase.
    - c. Construct concrete edge restraint to dimensions and level specified and support on a compacted subbase not less than 6 in (150 mm) thick.
- B. GEOTEXTILES
  1. Provide separation geotextile on bottom and sides of prepared soil subgrade. Secure in place to prevent wrinkling or folding from equipment tires and tracks.
  2. Overlap ends and edges a minimum of 18 in. (450 mm) in the direction of drainage.
- C. PERMEABLE BASE AND SUBBASE AGGREGATE
  1. Provide the Permeable Subbase Aggregate in uniform lifts not exceeding 6 in., (150 mm) loose thickness and compact to at least 95 percent as per ASTM D 4254 to depths as indicated.

2. Compact the Permeable Subbase Aggregate material with at least two passes in the vibratory mode then at least two in the static mode with a minimum 10 ton vibratory roller until there is no visible movement. Do not crush aggregate with the roller.
  3. Tolerance: Do not exceed the specified surface grade of the compacted Permeable Subbase Aggregate material more than  $\pm 3/4$  in. (20 mm) over a 10 ft. (3 m) long straightedge laid in any direction.
  4. Provide the Permeable Base Aggregate material in uniform lifts not exceeding 6 in. (150 mm) over the compacted Permeable Subbase Aggregate material and compact to at least 95 percent as per ASTM D 4254 to depths as indicated.
  5. Compact the Permeable Base Aggregate material with at least two passes in the vibratory mode then at least two in the static mode with a minimum 10 ton vibratory roller until there is no visible movement. Do not crush aggregate with the compaction device.
  6. Tolerance: Do not exceed the specified surface grade of the compacted Permeable Base Aggregate material more than  $\pm 1/2$  in. (13 mm) over a 10 ft. (3 m) long straightedge laid in any direction.
  7. Grade and compact the upper surface of the Permeable Base Aggregate material sufficiently to prevent infiltration of the Permeable Setting Bed Aggregate material both during construction and throughout its service life.
- D. PERMEABLE SETTING BED AGGREGATE
1. Provide and spread Permeable Setting Bed aggregate evenly over the Permeable Base Aggregate course and screed to a nominal thickness of 1-1/2 in. (40 mm).
    - a. Protect screeded Permeable Setting Bed Aggregate from being disturbed.
    - b. Screed only the area which can be covered by pavers in one day.
    - c. Do not use Permeable Setting Bed Aggregate material to fill depressions in the base surface.
  2. Keep moisture content constant and density loose and constant until Concrete Pavers are set and compacted.
  3. Inspect the Permeable Setting Bed Aggregate course prior to commencing the placement of the permeable concrete pavers.
  4. Inspect the Setting Bed Aggregate course prior to commencing the placement of the Permeable Concrete Pavers. Acceptance of the Setting Bed Aggregate occurs with the initiation of Permeable Concrete Paver placement.
- E. PERMEABLE CONCRETE PAVERS
1. Replace unit pavers with chips, cracks, voids, discolorations, and other defects that might be visible in finished work.
  2. Mix Concrete Pavers from a minimum of three (3) bundles simultaneously drawing the paver vertically rather than horizontally, as they are placed, to produce uniform blend of colors and textures. (Color variation occurs with all concrete products. This phenomenon is influenced by a variety of factors, e.g. moisture content, curing conditions, different aggregates and, most commonly, from different production runs. By installing from a minimum of three (3) bundles simultaneously, variation in color is dispersed and blended throughout the project).
  3. Exercise care in handling face mix pavers to prevent surfaces from contacting backs or edges of other units.
  4. Provide Permeable Concrete Pavers using joint pattern as indicated. Adjust joint pattern at pavement edges such that cutting of edge pavers is minimized. Cut all pavers exposed to vehicular tires no smaller than one-third of a whole paver.
  5. Use string lines or chalk lines on Permeable Setting Bed aggregate to hold all pattern lines true.
  6. Set surface elevation of pavers 1/8 in. (3 mm) above adjacent drainage inlets, concrete collars or channels.
  7. Place units hand tight against spacer bars. Adjust horizontal placement of laid pavers to align straight.

- a. When installation is performed with mechanical equipment, use only unit pavers with spacer bars on sides of each unit.
8. Provide space between paver units of 1/32 in. (1 mm) wide to achieve straight bond lines.
9. Prevent joint (bond) lines from shifting more than  $\pm 1/2$  in. ( $\pm 15$  mm) over 50 ft. (15 m) from string lines.
10. Fill gaps between units or at edges of the paved area that exceed 3/8 inch (10 mm) with pieces cut to fit from full-size unit pavers.
11. Cut unit pavers with motor-driven masonry saw equipment to provide clean, sharp, unchipped edges. Cut units to provide pattern indicated and to fit adjoining work neatly. Use full units without cutting where possible. Hammer cutting is not acceptable.
12. Prevent all traffic on installed pavers until Permeable Joint Aggregate has been vibrated into joints. Keep skid steer and forklift equipment off newly laid pavers that have not received initial compaction and Permeable Joint Aggregate material.
13. Vibrate pavers into leveling course with a low-amplitude plate vibrator capable of a to 5000-lbf (22-kN) compaction force at 80 to 90 Hz. Perform at least three passes across paving with vibrator. Vibrate under the following conditions:
  - a. After edge pavers are installed and there is a completed surface.
  - b. Compact installed concrete pavers to within 6 feet (1,800 mm) of the laying face before ending each day's work. Cover pavers that have not been compacted and leveling course on which pavers have not been placed, with nonstaining plastic sheets to prevent Permeable Setting Bed Aggregate from becoming disturbed.
14. Protect face mix Concrete Paver surface from scuffing during compaction by utilizing a urethane pad.
15. Remove any cracked or structurally damaged pavers and replace with new units prior to installing Permeable Joint Opening Aggregate material.
16. Provide, spread and sweep Permeable Joint Opening Aggregate into joints immediately after vibrating pavers into Permeable Setting Bed course until full. Vibrate pavers and add Permeable Joint Aggregate material until joints are completely filled, then remove excess material. This will require at least 4 passes with a plate compactor.
17. Remove excess Permeable Joint Aggregate broom clean from surface when installation is complete.

### 3.04 FIELD QUALITY CONTROL

- A. Verify final elevations for conformance to the drawings after sweeping the surface clean.
  1. Prevent final Concrete Paver finished grade elevations from deviating more than  $\pm 3/8$  in. ( $\pm 10$  mm) under a 10 ft (3 m) straightedge or indicated slope, for finished surface of paving.
- B. Lippage: No greater than 1/32 in. (0.8 mm) difference in height between Permeable Concrete Pavers and adjacent paved surfaces.

### 3.05 REPAIRING, CLEANING AND SEALING

- A. Remove and replace unit pavers that are loose, chipped, broken, stained, or otherwise damaged or that do not match adjoining units. Provide new units to match adjoining units and install in same manner as original units, with same joint treatment and with no evidence of replacement.
- B. Cleaning: Remove excess dirt, debris, stains, grit, etc. from exposed paver surfaces; wash and scrub clean.
  1. Clean Permeable Concrete Pavers in accordance with the manufacturer's written recommendations.

### 3.06 PROTECTION

- A. Protect completed work from damage due to subsequent construction activity on the site.

END OF SECTION

## SECTION 32 90 02 PLANTING

### PART 1 - GENERAL

#### 1.01 SUMMARY

- A. Provide planting where shown on Drawings as specified herein, and as needed for a complete and proper installation.
- B. Work shall include, but not be limited to:
  - 1. Shrub planting
  - 2. Native plug planting
  - 3. Tree planting

#### 1.02 RELATED DOCUMENTS

- A. Attention is directed to Bidding and Contracting requirements, Drawings and General Provisions of the Contract, including General Conditions, which are hereby made part of this Section.
- B. Related Sections:
  - 1. Erosion and Sedimentation Controls 31 20 00
  - 2. Plant Maintenance and Guarantee Period 32 90 03

#### 1.03 REFERENCE SPECIFICATIONS

- A. **AOSA** - Association of Official Seed Analysis: Rules for Testing Seeds, Journal of Seed Technology, 1991 Edition
- B. **TAPPI** - Technical Association of the Pulp and Paper Industry
- C. **AOAC** - Official Methods of Analysis, Association of Official Analytical Chemists
- D. Materials and work covered under this Section shall be in accordance with MDOT (2012 edition), Washtenaw County, and city of Ann Arbor standards and specifications for construction unless otherwise indicated. If a conflict exists between specifications, the more rigorous shall govern.

#### 1.04 QUALITY ASSURANCE

- A. The CONSULTANT may inspect plants at place of growth or on site prior to planting. Rejected material shall be immediately removed from site. Material damaged during planting may be rejected after planting. Material approved at place of growth, but damaged during transportation may also be rejected.
- B. Installation of plants shall be carried out by CONTRACTOR and their employees who are thoroughly experienced and skilled in the necessary crafts, and who are completely familiar with the specified requirements and methods needed for proper performance of the work of this section. The CONTRACTOR shall have a minimum of five (5) years documented experience in comparable work.
- C. Plant layout shall be reviewed by the CONSULTANT prior to completion. Planting zone shall be laid out with spray paint prior to planting in order for CONSULTANT to review.

#### 1.05 SUBMITTALS

- A. CONTRACTOR shall provide CONSULTANT with a list specifying sources of plant material 30 days after the contract award. CONTRACTOR shall review plant sources with consultant prior to ordering, and shall submit an invoice following purchase and delivery of plants.

#### 1.06 DELIVERY, STORAGE, AND HANDLING

- A. Plant material delivery shall be the same day as planting. No plants shall be stored at the site without permission of the CONSULTANT. Plants shall be carefully loaded and unloaded so as not to damage branching or root mass. Dropping of material will not be allowed. Plants in full leaf shall be thoroughly wetted down and completely covered with a wet tarp during transportation.
- B. All plant roots must be kept in a moist condition.
- C. Digging of plant material shall be during the dormant season, preferably between 1 October and 1 May. Plant material which is poorly packed, or which arrives with the roots in a dry condition, as a result of improper packing, delay in transit, or from any other cause, will not be accepted. Stock shall be handled in such a manner that the roots shall remain intact, the branches unbroken, and the bark intact and not

loosened from the wood. Stock shall be protected from drying and from temperatures below 50°F and in excess of 90°F prior to planting.

- D. The CONTRACTOR shall complete all planting prior to the ground freezing.

## **PART 2 - PRODUCTS**

### **2.01 PLANTS - GENERAL**

- A. Material shall be of the size, genus, species, variety, and any other special designation as shown and scheduled for on the Drawings, on the attached Proposal Form or in these Specifications. No substitution of species, variety, or size shall be accepted without written approval from the CONSULTANT and OWNER. Plant material shall be nursery grown under climatic conditions similar to those in the locality of the project.
- B. Plants shall comply with the recommendations and requirements of ANSI Z60.1 "American Standard for Nursery Stock." Plants shall be healthy, vigorous stock grown in a recognized nursery in accordance with good horticultural practice, and free of disease, insects, eggs, larvae, and defects such as knots, sunscald, injuries, abrasions, or disfigurement.
  - 1. Plants balled with plastic burlap will not be accepted.
- C. All plants shall be labeled with securely-attached waterproof tab bearing legible designation of botanical and common name.
- D. Formal arrangements, if shown on Planting Plan, shall have trees selected for uniform height and spread.

### **2.02 NATIVE PLUGS**

- A. Plugs shall be of native plant material of genotypes from the north central states only (MI, IL, IN, WI, OH), and from a recognized nursery of this region. The CONTRACTOR shall make every effort to identify Michigan sources for plugs, before endeavoring to locate plugs from suppliers in other north central states.
- B. Plug sources for the native plugs are available through The Native Plant Nursery (1.734.677.3260), WildType Native Plant Nursery (1.517.244.1140), or approved substitution.

### **2.03 PRE-PLANTING SUPPORT**

- A. Material for support through transplanting shock shall be Bio-Plex Technical Transplant Concentrate and Plant Enhancer or approved substitution. This product is available through Bio-plex, Inc. (1.800.441.3573).

### **2.04 WATER**

- A. Source: If not available on site, water shall be provided by the CONTRACTOR.
- B. Quality: Water supplied by the CONTRACTOR shall be free of substances harmful to plant growth.

### **2.05 MULCH**

- A. Material around isolated trees and in planting bed areas shall be shredded hardwood bark free of weeds, soil, sticks or trash, and shall have a uniform appearance. A sample shall be approved by CONSULTANT prior to application.
  - 1. Colored or dyed mulch will not be accepted.

### **2.06 LOCATION STAKES**

- A. Stakes for plant locations shall be 1 inch X 2 inches X 3 foot wood, and supplied by the CONTRACTOR.

### **2.07 TREE SUPPORT**

- A. Stakes for tree support shall be 2-inch x 2-inch hardwood stakes or approved equal driven 6-8 inches outside of the rootball.
- B. Support shall be 2-3 inches wide belt-like nylon or plastic straps. DO NOT USE rope or wire encased in a hose.

### **2.08 STEEL EDGING**

- A. Steel edging shall be painted DURAEDGE, 3/16-inch thick x 4-inch depth with interlocking joints, corner joints and steel stakes, as manufactured and supplied by The J.D. Russell Company, (1.800.888.9708), or approved substitution.
- B. Color shall be determined by OWNER prior to ordering.

## **PART 3 - EXECUTION**

### **3.01 PLANTING SUPPORT**

- A. If trees and/or shrubs are planted from May through August, or when there are drought conditions during September through April, the CONTRACTOR shall provide planting support to each balled and burlapped specimen with Bio-Plex Technical Transplant Concentrate and Plant Enhancer (per manufacturer's instructions on label) by means of:
  - 1. A foliar application (through spray) upon receipt of trees and shrubs
  - 2. A root application (through tree gators) upon planting of trees and shrubs

### **3.02 LAYOUT**

- A. Locations of trees, shrubs, perennials, and groundcover shall be established by the CONTRACTOR according to Plans.
- C. Trees and shrubs shall be laid out in their containers on top of the ground.
- D. Areas for native plugs shall be laid out by paint.
- E. The CONTRACTOR shall notify the CONSULTANT when staking and layout is completed and allow two working days for modifications and notice to proceed with planting.

### **3.03 TREE and SHRUB PLANTING**

- A. Balled and/or container stock as per detail:
  - 1. Set plants plumb.
  - 2. **B&B STOCK:**
    - a. Remove all bindings and burlap from top one half of ball and remove from site.
    - b. Cut wires of basket and fold completely down into hole.
  - 3. **CONTAINER STOCK:**
    - a. Remove all containers and packaging material before planting and remove from site.
  - 4. Backfill with planting mix. Water and foot compact at intervals. Do not damage root structure.
  - 5. Mulch to a depth as shown on the Drawings and soak the mulch with water. Thoroughly soak root ball with water. Mulch is not necessary for prairie shrubs.
  - 6. Prune all dead wood at first live lateral bud in accordance with standard horticultural practices using sharp instruments cleaned frequently. If necessary, any additional pruning will be directed by the CONSULTANT. Do not prune terminal leader or branch tips. A plant's natural form shall not be compromised by any pruning activities. Promptly remove all pruned material from site.
  - 7. **STAKE** all trees as follows:
    - a. Stakes shall be driven 6-8 inches outside of the rootball.
    - b. Loosely stake tree to allow for trunk flexing.
    - c. Attach support straps around tree trunk just below first branch of tree (two per tree on opposite sides of the tree).
    - d. Remove all tree support after one year.
  - 8. Remove all nursery applied tree wrap, tape or string from trunk and crown. Remove any tags or labels and remove from site.

### **3.04 NATIVE PLUG INSTALLATION**

- A. Native plug stock as per detail:
  - 1. Remove all containers and packaging material before planting and remove from site.
  - 2. Set plants plumb.
  - 3. Do not damage root structure.
  - 4. Thoroughly soak root matter with water.
  - 5. See 'Watering' in the – PLANT MAINTENANCE AND GUARANTEE PERIOD Section (32 90 03) – for watering during the establishing period.
- B. In areas where both plugs and erosion control blanket are present, plugs shall be planted through the blanket after its installation.
- C. The CONTRACTOR shall be responsible to keep the plugs adequately watered, as necessary, to ensure their survival. This may mean more visits than are outlined in the PLANT MAINTENANCE AND GUARANTEE PERIOD Section (32 90 03).



### **3.05 PERENNIAL INSTALLATION**

- A.** Container stock as per detail:
  - 1. Remove all containers and packaging material before planting and remove from site.
  - 2. Set plants plumb.
  - 3. Backfill with planting mix. Do not damage root structure.
  - 4. Mulch to a depth as shown on the Drawings and soak the mulch with water. Thoroughly soak root matter with water.

### **3.06 EROSION CONTROL**

- A.** The CONTRACTOR will be required to maintain adequate erosion control measures on the site, to prevent erosion and sedimentation from the planting process, stockpiling, or moving of material, as well as during the period of plant establishment.

### **3.07 STEEL EDGING**

- A.** DURAEDEGE Steel Edging
  - 1. Install per manufacturer's standards and specifications around beds as shown on Plans.

### **3.08 MULCHING**

- A.** For all planting areas, cover with undyed shredded hardwood bark mulch to a depth shown on the Drawings.

### **3.09 ESTABLISHMENT AND ACCEPTANCE: RAIN GARDEN AND LANDSCAPE BED PLANTING AREAS**

- A.** It may be necessary to pump standing water out of rain garden planting areas during the establishment period.
- B.** Watering: The CONTRACTOR shall keep plugs moist for optimum plant growth (one (1) inch of total water per week, including rainfall).
- C.** Erosion shall be repaired by the CONTRACTOR.
- D.** Protection from traffic and erosion in newly planted areas is the responsibility of the CONTRACTOR. Safety fences and/or silt fence with appropriate signage may be used at the CONTRACTOR's expense until the grasses and flowers are fully established.
- E.** Final acceptance will be when all of the above including subsequent weed control requirements and guarantee of materials as specified in the – PLANT MAINTENANCE AND GUARANTEE Section (32 90 03) – of these Specifications have been met.

**END OF SECTION**

## SECTION 32 90 03 PLANT MAINTENANCE and GUARANTEE PERIOD

### PART 1 - GENERAL

#### 1.01 SUMMARY

- A. The CONTRACTOR shall furnish all labor, materials, equipment, transportation, services, and necessary appurtenant work as required to complete the work as shown on the Plans and/or as specified herein.
- B. Extent of work shall include but not be limited to:
  - 1. Weed control
  - 2. Disease and insect control
  - 3. Pruning
  - 4. Fertilizer application
  - 5. Mulching
  - 6. Removal of plant support and tags (if any)
  - 7. Watering
  - 8. Maintenance and guarantee of plant material for two (2) periods

#### 1.02 RELATED DOCUMENTS

- A. Attention is directed to Bidding and Contracting requirements, Drawings, and General Provisions of the Contract, including General Conditions, which are hereby made part of this Section.
- B. Related Sections:
  - 1. Planting 32 90 02

#### 1.03 REFERENCE SPECIFICATION

- A. Materials and work covered under this Section shall be in accordance with MDOT (2012 edition), Washtenaw County, and City of Ann Arbor Standards Specifications for Construction unless otherwise indicated. If a conflict exists between specifications, the more rigorous shall govern.

#### 1.04 QUALITY ASSURANCE

- A. CONTRACTOR to use adequate numbers of skilled workmen who are thoroughly trained and experienced in the necessary crafts, and who are completely familiar with the specified requirements and the methods needed for proper performance of the work of this Section.

#### 1.05 DEFINITIONS

- A. Maintenance and Guarantee Period: The first maintenance and guarantee period begins upon written notification of substantial completion and continues for two (2) years.
- B. Native Planting: Native planting refers to areas seeded and/or plugged with native plant material.

#### 1.06 SCHEDULE

- A. At the final acceptance of the planting, the CONSULTANT will send, in writing, a letter stating substantial completion. From that date forward, the maintenance and guarantee period will continue for two (2) years.
- B. Schedule: A minimum of one (1) visit is required for each of the following time periods during the first and second maintenance and guarantee periods. During each visit, CONTRACTOR shall complete all necessary tasks to comply with the requirements outlined in these specifications.
  - 1. 1 April to 15 April
  - 2. 1 May to 15 May
  - 3. 1 June to 15 June
  - 4. 1 July to 15 July
  - 5. 1 August to 15 August
  - 6. 1 September to 15 September
- C. Verification of visits, in the form of reports and certified payroll covering visits, shall be provided to the OWNER and CONSULTANT.

### 1.07 DELIVERY, STORAGE AND HANDLING

- A. Packaged materials shall be delivered in original containers showing weight, analysis, and name of manufacturer. Protect materials from deterioration during delivery and storage.

## PART 2 - PRODUCTS

### 2.01 PESTICIDES & HERBICIDES

- A. Materials shall comply with local, state, and federal regulations.
- B. Common integrative pest management (IPM) practices shall be followed. Pesticides and herbicides shall be used as a last resort.
- C. Herbicide-A. Glyphosate, a nonselective herbicide shall be used to eradicate existing vegetation. It shall be used according to the manufacturer's label.
- D. Herbicide-B. Sethoxydim, a selective herbicide shall be used to selectively remove invasive grass from prairie planting and wet meadow planting (if not adjacent to water). It shall be used according to the manufacturer's label.
- E. Herbicide-C. Rodeo, a non-selective herbicide shall be used to eradicate existing vegetation in wet meadow areas adjacent to open water. It shall be used according to the manufacturer's label.

### 2.02 FERTILIZER

- A. Materials shall conform to the standards of the Association of Agricultural Chemists and shall comply with state and federal regulations.
- B. Fertilizer for woody plants shall be an organic, slow release with a ratio of 3-1-2 or 3-1-1 or approved substitution.
- C. Maintenance fertilizer for lawn shall contain no phosphorus, shall be derived from an organic product, and slow release with a ratio of 27-0-12 or approved substitution. Fertilizer available from Downtown Home and Garden, (1.734.662.8122).
- D. There shall be no fertilizer applied to native planting areas.

### 2.03 WATER

- A. Source: If not available on site, shall be provided by the CONTRACTOR.
- B. Quality: Water supplied by the CONTRACTOR shall be free of substances harmful to plant growth.

### 2.04 MULCH

- A. Material shall be shredded hardwood bark free of weeds, soil, sticks, or trash, and of a uniform appearance.
  - 1. Colored or dyed mulch will not be accepted.

## PART 3 - EXECUTION

### 3.01 DISEASE and INSECT CONTROL

- A. Monitoring for diseases and insects shall be the responsibility of the CONTRACTOR. The CONTRACTOR shall monitor all plants at all times for disease and insect problems.
- B. Treatment shall take place in accordance with common IPM practices.
- C. Pesticides shall only be used when and where necessary as approved by the OWNER. Manufacturer's directions and precautions must be followed rigorously. Applicators shall be licensed by the State of Michigan. Applicators shall be knowledgeable in the application of pesticides and appropriate equipment used. Excess pesticides shall be properly removed from the site.

### 3.02 PRUNING

- A. Prune all dead wood at first live lateral bud in accordance with standard horticulture practices using sharp instruments cleaned frequently. Pruning shall enhance plant development and ornamental qualities. Do not prune terminal leader or branch tips. A plant's natural form shall not be compromised by any pruning activities.
- B. Additional pruning may be required at the request of the OWNER in order to decrease public liability factors.
- C. Remove immediately after pruning all dead, broken and diseased growth and other pruning debris from the site, and dispose of in an environmentally sensitive manner.
- D. Plant material that is "topped" by the CONTRACTOR shall be replaced at the CONTRACTOR's expense.

### 3.03 MAINTENANCE FERTILIZER APPLICATION

- A. Application shall be according to manufacturer's directions.
- B. Woody plants
  - 1. Maintenance fertilizer application for woody plants shall occur in November of the second maintenance and guarantee period.
  - 2. Topdress at a rate of one (1) pound of nitrogen per 1,000 square feet.
- C. Lawn
  - 1. Maintenance fertilizer application for lawn shall occur in May and October of the first and second maintenance and guarantee periods. For spring seeding, commencement of maintenance fertilizer shall begin the subsequent fall. For fall seeding, commencement of maintenance fertilizer shall begin the subsequent spring.
  - 2. For May fertilizing, topdress at a rate of ½ pound of nitrogen per 1,000 square feet.
  - 3. For October fertilizing, topdress at a rate of 1.5 pounds of nitrogen per 1,000 square feet.

### 3.04 MULCHING

- A. Monitoring: All mulch beds shall be reviewed in June and September for each maintenance and guarantee period. Any beds that do not meet the following conditions shall be replenished.
  - 1. Depth shall be three (3) inches typical shredded hardwood bark for individual trees.
  - 2. Depth shall be two (2) inches typical shredded hardwood bark for all rain gardens and landscape beds.
  - 4. Keep mulch four (4) inches away from root collar of trees.

### 3.05 REMOVAL of TREE SUPPORT and TAGS

- A. Repair all damaged guys and stakes during first maintenance and guarantee period.
- B. Remove all stakes, guys, labels, and support material at the end of the first maintenance and guarantee period and remove from site.

### 3.06 WATERING

- A. Monitor all plants during site visits for water stress.
- B. Water as required to keep all plants in optimum health—**this may exceed the time windows outlined in the schedule**. For all plantings, apply water in a slow trickle to allow water to penetrate down into root zone of plant.
- C. Native plugs in the deepest ponding area may require more watering than other planting areas.
- D. Adjust frequency and length of time for watering cycles according to changing soil and weather conditions. The CONTRACTOR is responsible for watering as necessary for plant survival at no additional cost to the OWNER.

### 3.07 WEED CONTROL: ALL PLANTING AREAS

- A. Weeding of all planting areas shall occur prior to invasive weed species (sweet clover, burdock, wild carrot, purple knapweed, purple loosestrife, phragmites, barnyard grass, lamb's quarters, plantain, creeping Charlie, bindweed, etc.) setting their seed or as determined by CONSULTANT.
- B. Frequency shall be every visit.
- C. Weeds shall be removed by hand. Before application of any herbicide the CONTRACTOR shall receive approval of the OWNER. A selective herbicide shall be applied according to manufacturer's directions.
- D. Post planting management procedures for rain garden planting area may consist of, but are not limited to the following:
  - 1. Pull invasive weed species to remove root.
  - 2. Spring or fall dormant seasons application of a non-selective herbicide to control invasive weeds as directed by the OWNER.
  - 3. Summer application of a selective herbicide to control invasive weeds as directed by the OWNER.
  - 4. A late winter/early spring burn to encourage native plants, control invasive weeds and prevent excessive build-up of thatch. This may take place outside of outlined maintenance visit times if optimum burning conditions exist. Any burn plans must be coordinated with the OWNER.
- E. Acceptance will be when all the above requirements have been met.

**3.08 SPRING CLEAN-UP**

- A. During the first spring maintenance visit at least six (6) months after planting, the CONTRACTOR is responsible to cut all standing dead vegetation and remove it from the site.

**3.09 GUARANTEE of MATERIAL**

- A. The CONTRACTOR shall guarantee 100% survival of all plant material.
- B. Responsibilities: The CONTRACTOR shall replace, at no cost to the OWNER, all dead woody and one gallon pot perennial vegetation during the maintenance and guarantee period.
- C. Judgment of the plants' health will be the CONSULTANT'S or the OWNER's.
- D. Planting methods shall be the same as specified herein and in the planting details unless directed by the CONSULTANT.
- E. Plants replaced during the maintenance and guarantee period are only under guarantee during those periods.

**END OF SECTION**

# 221 - 253 S. Seventh Street

## Hardscape & Green Infrastructure Improvements

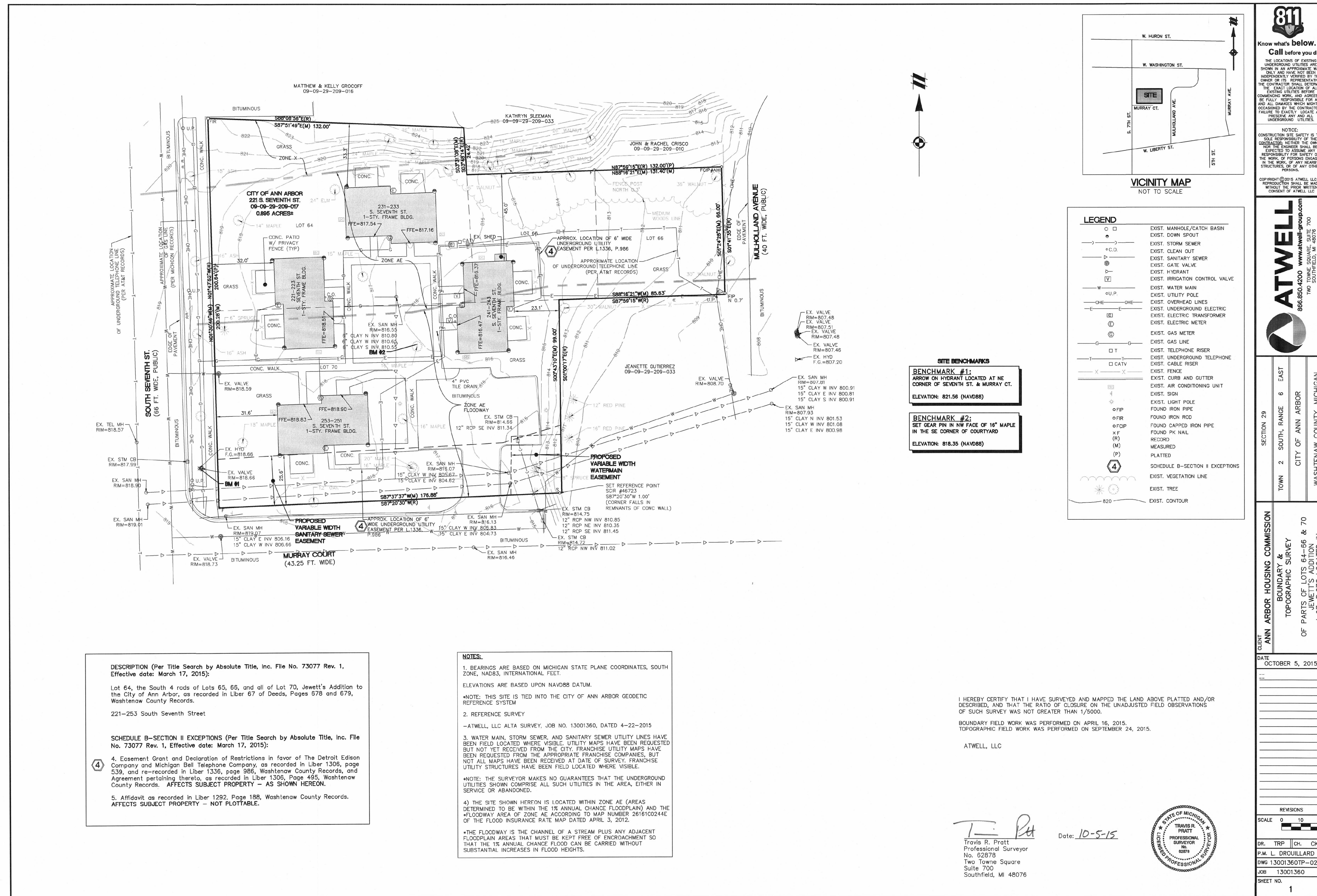

SEALED SURVEY

### SHEET INDEX:

- L-1 Cover
- L-2 Demolition and Soil Erosion and Sedimentation Plan
- L-3 Layout Plan
- L-4 Grading Plan
- L-5 Landscape Plan
- L-6 Details

### PROJECT CONSULTANT:

**INSITE**  
 InSite Design Studio  
 412 Longshore Drive  
 Ann Arbor, MI 48105  
 Shannan Gibb-Randall, PLA  
 (p) 734-995-4194  
 (e) sgibb-randall@insite-studio.com

**Project:**  
 221 - 253 S. 7th St. Hardscape & Green Infrastructure Improvements  
 Ann Arbor Housing Commission

**Date:** 5 October 2016  
**Issued for:** Bidding  
 27 February 2017

**Scale:** 1" = 10'-0"  
**Drawn by:** LAN

**Title:**  
 Cover

**Sheet:**

**L-1**

BEFORE YOU DIG  
 CALL MISS DIG  
 800-482-7171  
 MISS DIG

CONTRACTOR is responsible to field verify location of all underground utilities prior to any work.

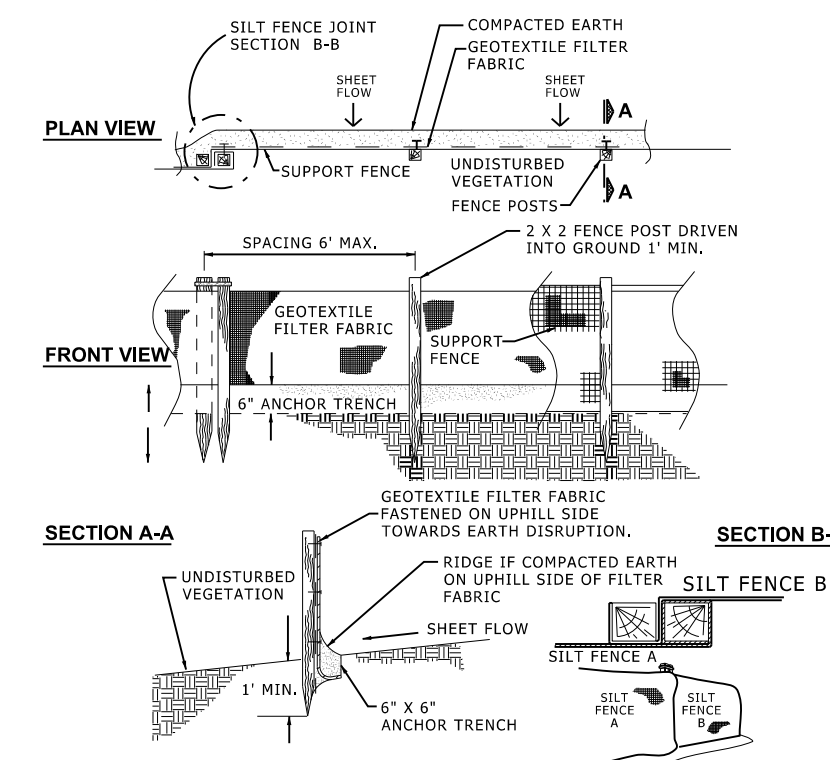
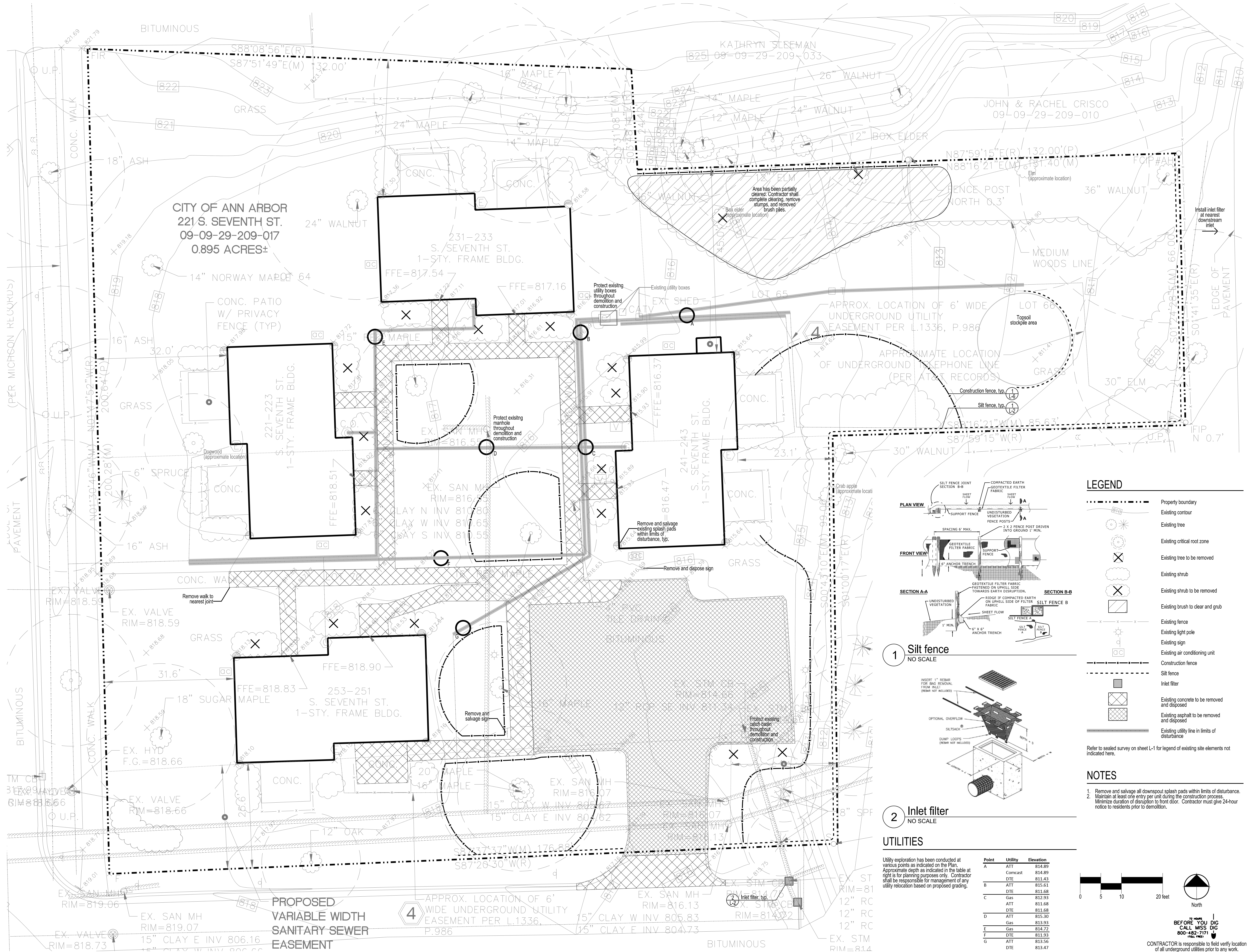

### LEGEND

- Property boundary
- Existing contour
- Existing tree
- Existing critical root zone
- Existing tree to be removed
- Existing shrub
- Existing shrub to be removed
- Existing brush to clear and grub
- Existing fence pole
- Existing light pole
- Existing sign
- Existing air conditioning unit
- Construction fence
- Silt fence
- Inlet filter
- Existing concrete to be removed and disposed
- Existing asphalt to be removed and disposed
- Existing utility line in limits of disturbance

### NOTES

1. Remove and salvage all downspout splash pads within limits of disturbance.
2. Maintain at least one entry per unit during the construction process. Minimize duration of disruption to front door. Contractor must give 24-hour notice to residents prior to demolition.

Project:  
**221 - 253 S. 7th St. Hardscape & Green Infrastructure Improvements**  
Ann Arbor Housing Commission

Date:  
5 October 2016  
27 February 2017

Issued for:  
Bidding  
Bidding

Scale: 1" = 10'-0"  
Drawn by: LAN

Title:  
**Site Preparation, Demolition, and SESC Plan**

Sheet:

**L-2**

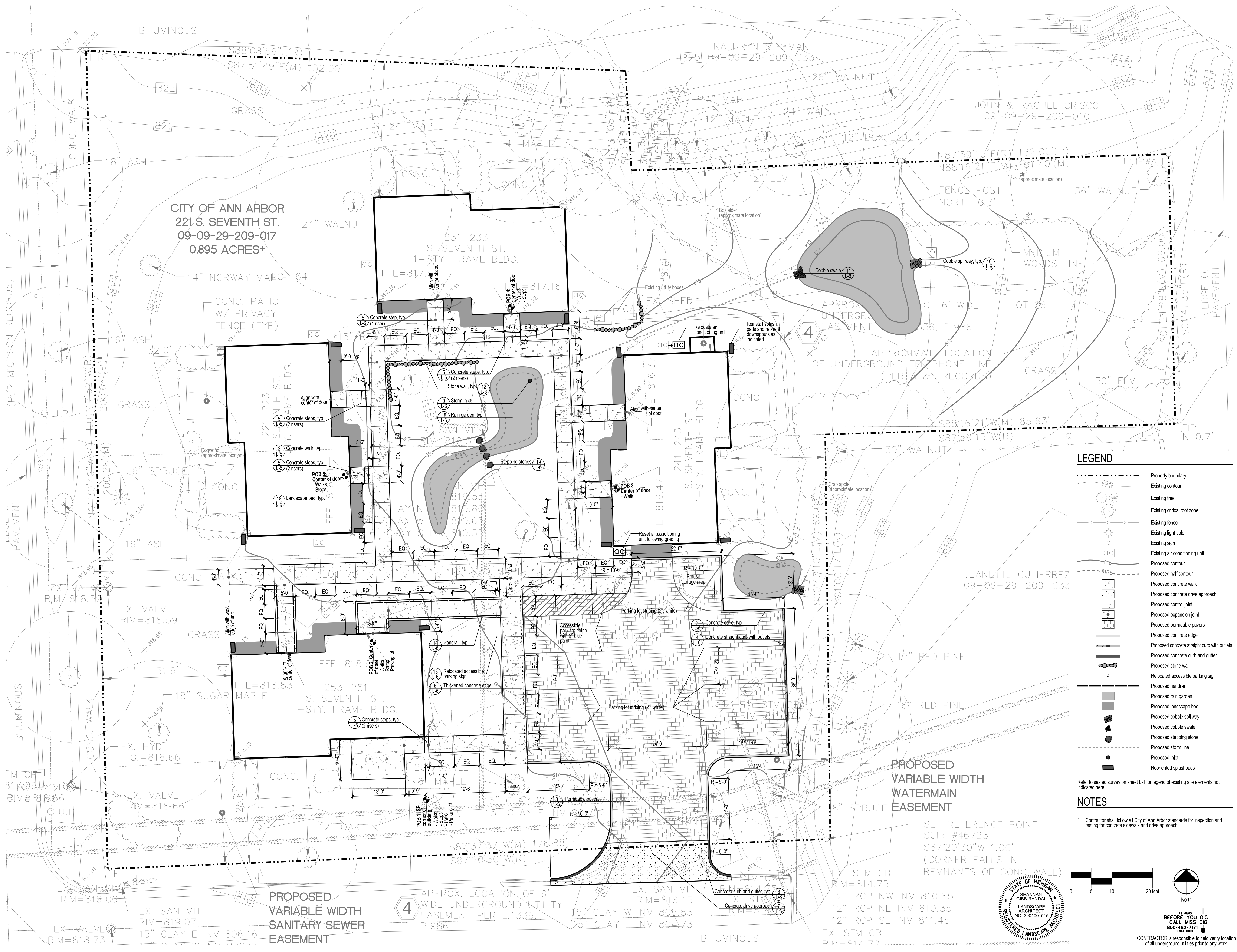

CITY OF ANN ARBOR  
221 S. SEVENTH ST.  
09-09-29-209-017  
0.895 ACRES±

231-233  
S. SEVENTH ST.  
1-STY. FRAME BLDG.  
FFE=817

221-223  
S. SEVENTH ST.  
1-STY. FRAME BLDG.  
FFE=818

253-251  
S. SEVENTH ST.  
1-STY. FRAME BLDG.  
FFE=818.83

**LEGEND**

- Property boundary
- Existing contour
- Existing tree
- Existing critical root zone
- Existing fence
- Existing light pole
- Existing sign
- Existing air conditioning unit
- Proposed contour
- Proposed half contour
- Proposed concrete walk
- Proposed concrete drive approach
- Proposed control joint
- Proposed expansion joint
- Proposed permeable pavers
- Proposed concrete edge
- Proposed concrete straight curb with outlets
- Proposed concrete curb and gutter
- Proposed stone wall
- Relocated accessible parking sign
- Proposed handrail
- Proposed rain garden
- Proposed landscape bed
- Proposed cobble spillway
- Proposed cobble swale
- Proposed stepping stone
- Proposed storm line
- Proposed inlet
- Reoriented splashpads

**NOTES**

1. Contractor shall follow all City of Ann Arbor standards for inspection and testing for concrete sidewalk and drive approach.

**PROPOSED  
VARIABLE WIDTH  
WATERMAIN  
EASEMENT**

SET REFERENCE POINT  
SCIR #46723  
S87°20'30"W 1.00'  
(CORNER FALLS IN  
REMNANTS OF CONC WALL)



CONTRACTOR is responsible to field verify location of all underground utilities prior to any work.



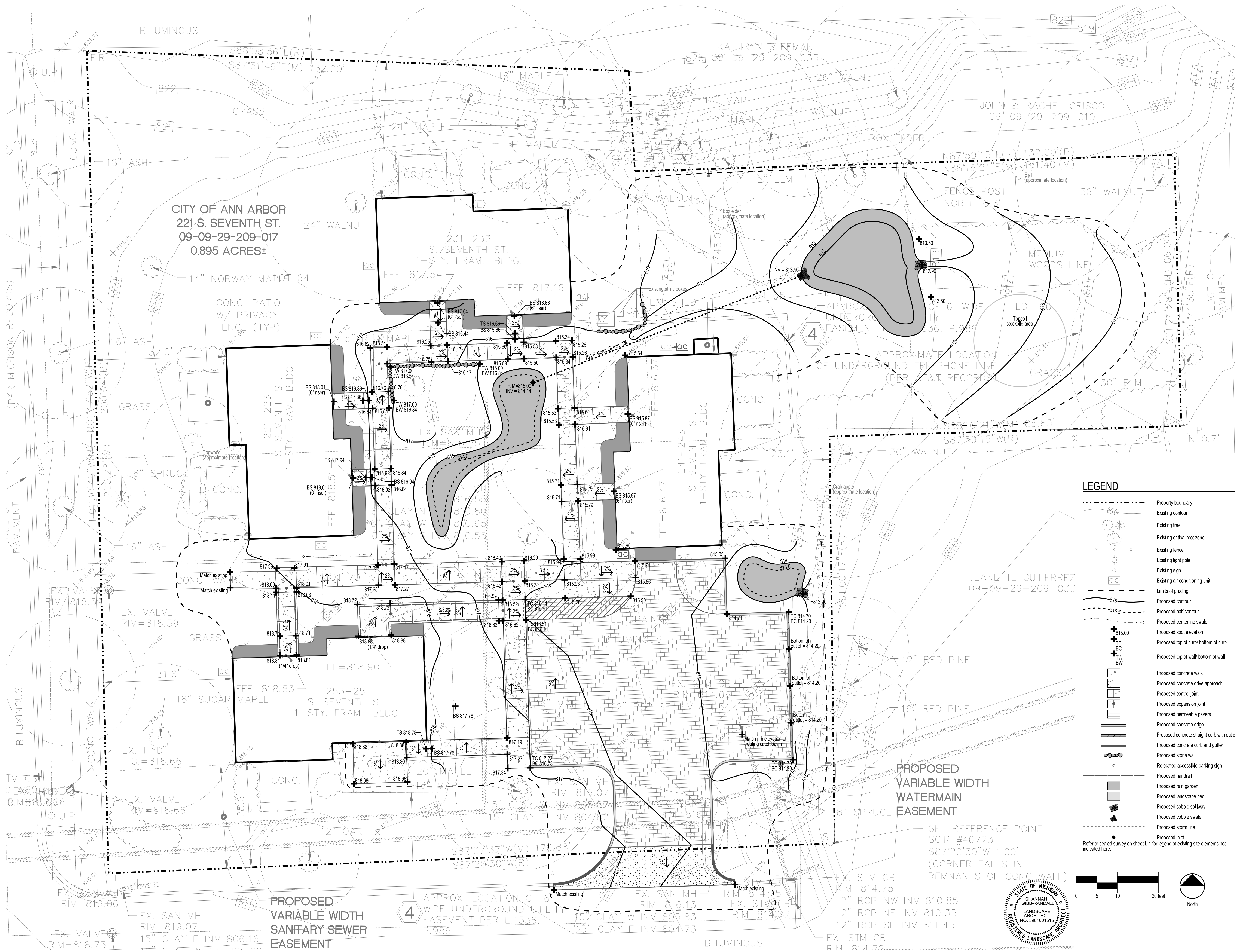

### LEGEND

- Property boundary
  - Existing contour
  - Existing tree
  - Existing critical root zone
  - Existing fence
  - Existing light pole
  - Existing sign
  - Existing air conditioning unit
  - Limits of grading
  - Proposed contour
  - Proposed half contour
  - Proposed centerline swale
  - Proposed spot elevation
  - Proposed top of curb/ bottom of curb
  - Proposed top of wall/ bottom of wall
  - Proposed concrete walk
  - Proposed concrete drive approach
  - Proposed control joint
  - Proposed expansion joint
  - Proposed permeable pavers
  - Proposed concrete edge
  - Proposed concrete straight curb with outlets
  - Proposed concrete curb and gutter
  - Proposed stone wall
  - Relocated accessible parking sign
  - Proposed handrail
  - Proposed rain garden
  - Proposed landscape bed
  - Proposed cobble spillway
  - Proposed cobble swale
  - Proposed storm line
  - Proposed inlet
- Refer to sealed survey on sheet L-1 for legend of existing site elements not indicated here.

### PROPOSED VARIABLE WIDTH WATERMAIN EASEMENT

SET REFERENCE POINT  
SCIR #46723  
S87°20'30"W 1.00'  
(CORNER FALLS IN  
REMNANTS OF CONC WALL)

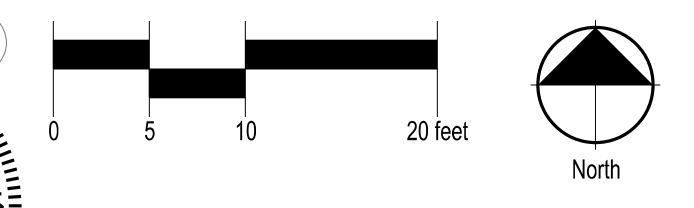

**Project:**  
221 - 253 S. 7th St. Hardscape & Green Infrastructure Improvements  
Ann Arbor Housing Commission

**Date:** 5 October 2016  
**Issued for:** Bidding  
27 February 2017

**Scale:** 1" = 10'-0"  
**Drawn by:** LAN

**Title:**  
Grading Plan

**Sheet:**  
L-4

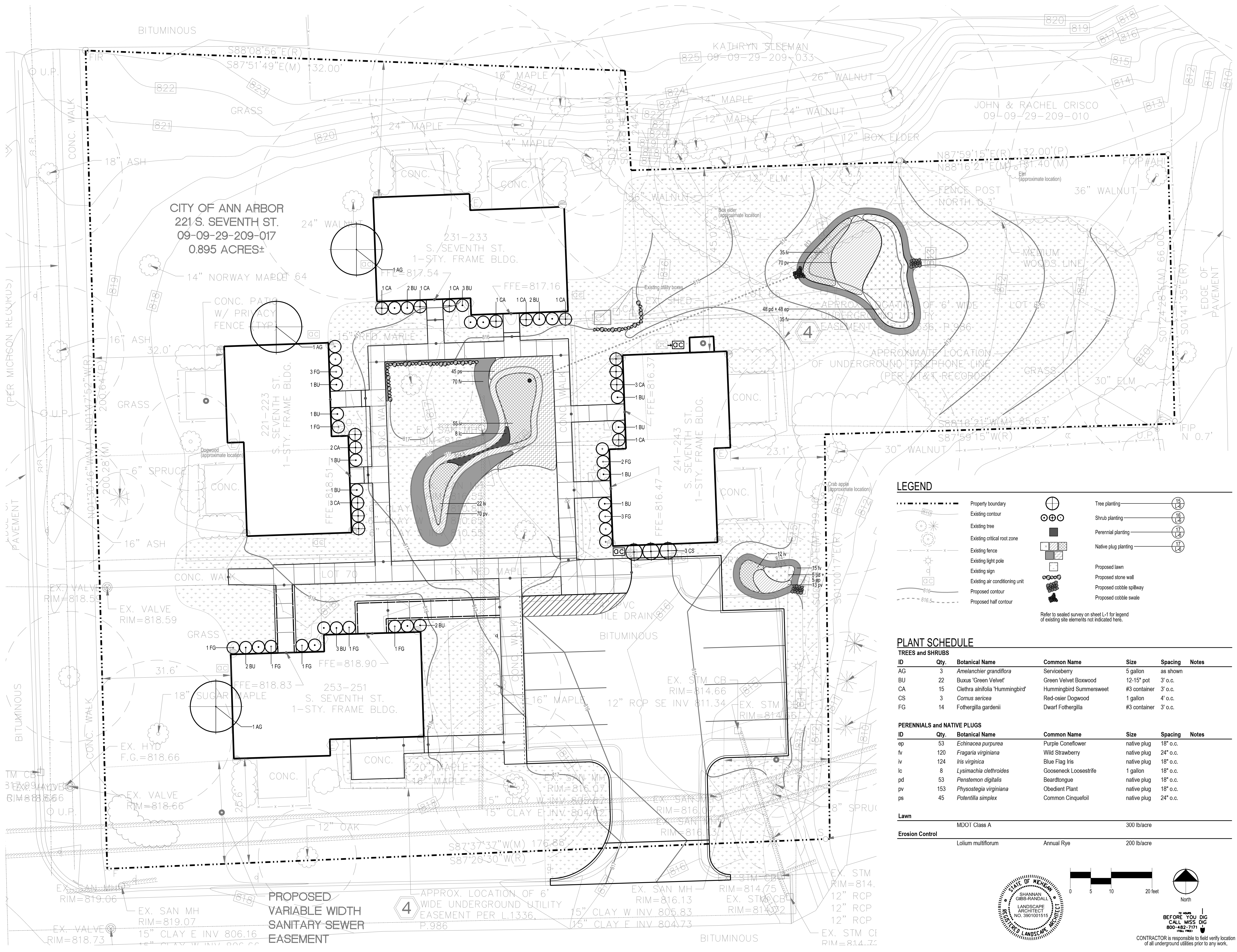

**LEGEND**

	Property boundary		Tree planting
	Existing contour		Shrub planting
	Existing tree		Perennial planting
	Existing critical root zone		Native plug planting
	Existing fence		Proposed lawn
	Existing light pole		Proposed stone wall
	Existing sign		Proposed cobble spillway
	Existing air conditioning unit		Proposed cobble swale
	Proposed contour		
	Proposed half contour		

Refer to scaled survey on sheet L-1 for legend of existing site elements not indicated here.

**PLANT SCHEDULE**

TREES and SHRUBS					
ID	Qty.	Botanical Name	Common Name	Size	Spacing Notes
AG	3	<i>Amelanchier grandiflora</i>	Serviceberry	5 gallon	as shown
BU	22	<i>Buxus 'Green Velvet'</i>	Green Velvet Boxwood	12-15" pot	3' o.c.
CA	15	<i>Clethra alnifolia 'Hummingbird'</i>	Hummingbird Summersweet	#3 container	3' o.c.
CS	3	<i>Cornus sericea</i>	Red-osier Dogwood	1 gallon	4' o.c.
FG	14	<i>Fothergilla gardenii</i>	Dwarf Fothergilla	#3 container	3' o.c.

PERENNIALS and NATIVE PLUGS					
ID	Qty.	Botanical Name	Common Name	Size	Spacing Notes
ep	53	<i>Echinacea purpurea</i>	Purple Coneflower	native plug	18" o.c.
fv	120	<i>Fragaria virginiana</i>	Wild Strawberry	native plug	24" o.c.
iv	124	<i>Iris virginica</i>	Blue Flag Iris	native plug	18" o.c.
lc	8	<i>Lysimachia clethroides</i>	Gooseneck Loosestrife	1 gallon	18" o.c.
pd	53	<i>Penstemon digitalis</i>	Beardtongue	native plug	18" o.c.
pv	153	<i>Physostegia virginiana</i>	Obedient Plant	native plug	18" o.c.
ps	45	<i>Potentilla simplex</i>	Common Cinquefoil	native plug	24" o.c.

Lawn		
Material	Rate	Notes
MDOT Class A	300 lb/acre	

Erosion Control		
Material	Rate	Notes
Lolium multiflorum Annual Rye	200 lb/acre	



CONTRACTOR is responsible to field verify location of all underground utilities prior to any work.

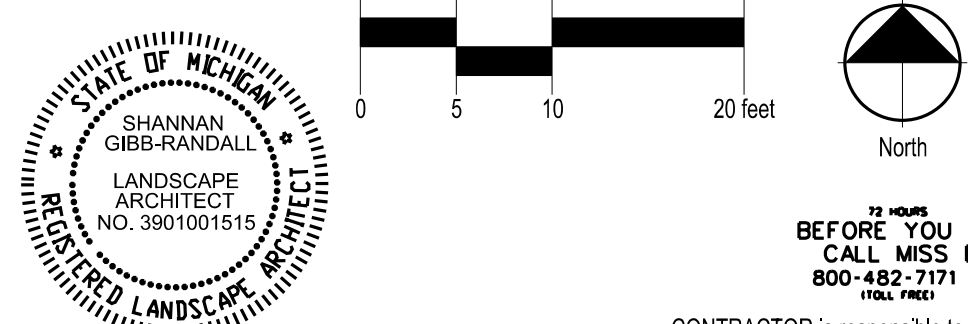

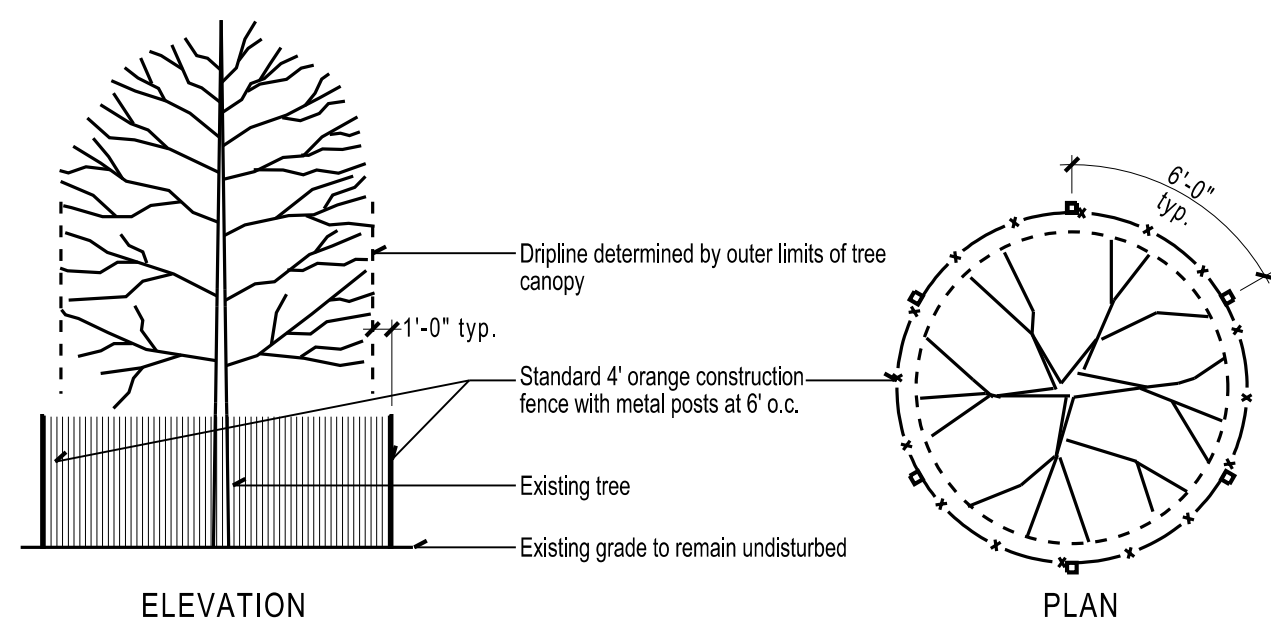
**NOTES:**  
 1. The fence shall be located a minimum of one (1) foot outside the drip line of the tree to be saved or closer only at the direction of City of Ann Arbor Forestry staff.  
 2. Tree protection is to be erected prior to any earthwork or construction and is to remain in place until construction and grading is complete.  
 3. All debris, fill, equipment, or material is to be kept clear of area within protective fence. No cleaning of equipment or storage or disposal of any material within the drip line of any trees to be saved.  
 4. No activity including parking, driving of vehicles, pedestrian routing, staging lay down or storage of material will be allowed within the tree protective zones (to edge of drip line).

**1 Construction fence**  
NO SCALE

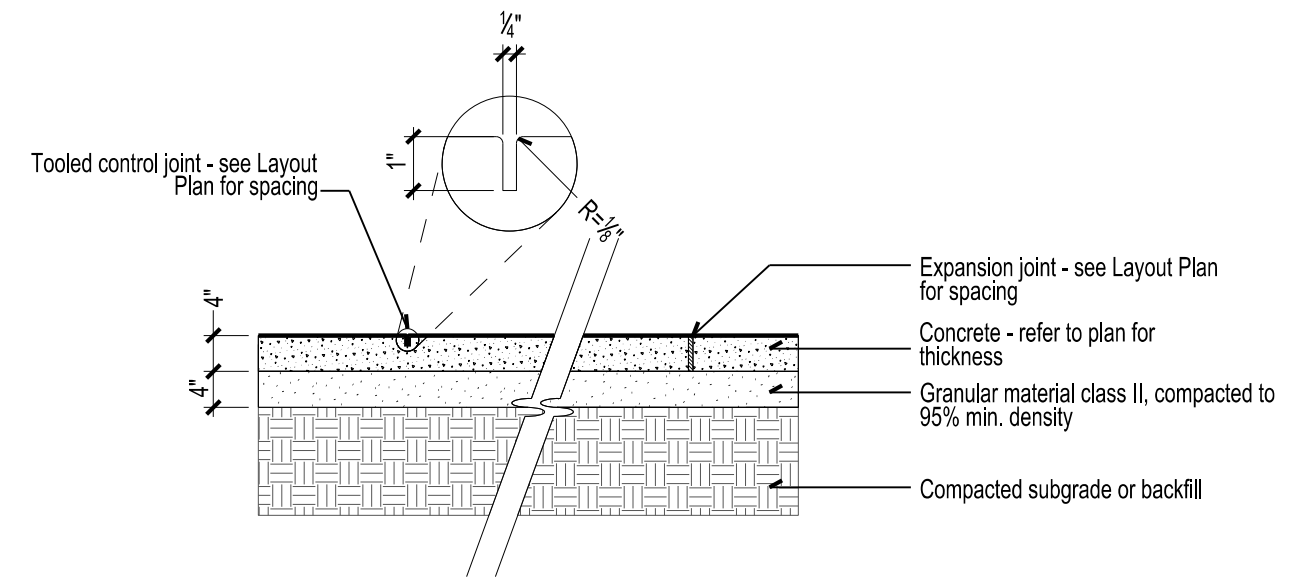

**2 Concrete walk**  
NO SCALE

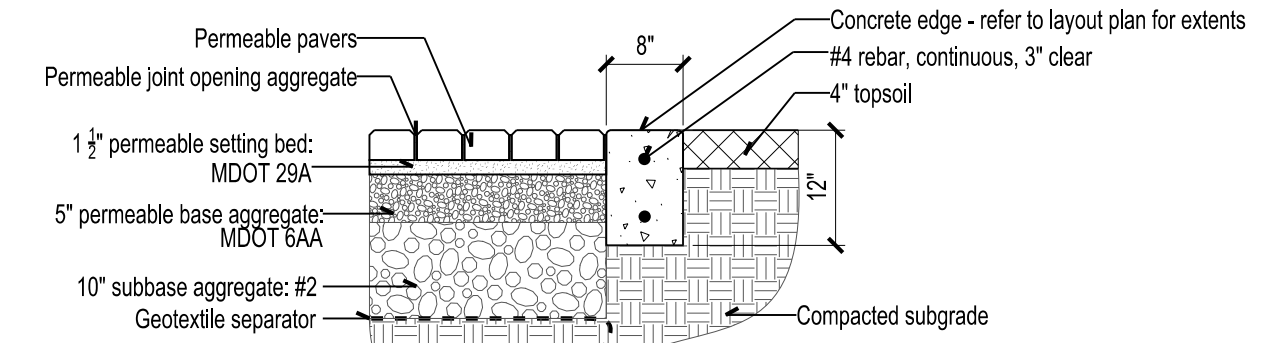

**3 Permeable pavers and concrete edge**  
NO SCALE

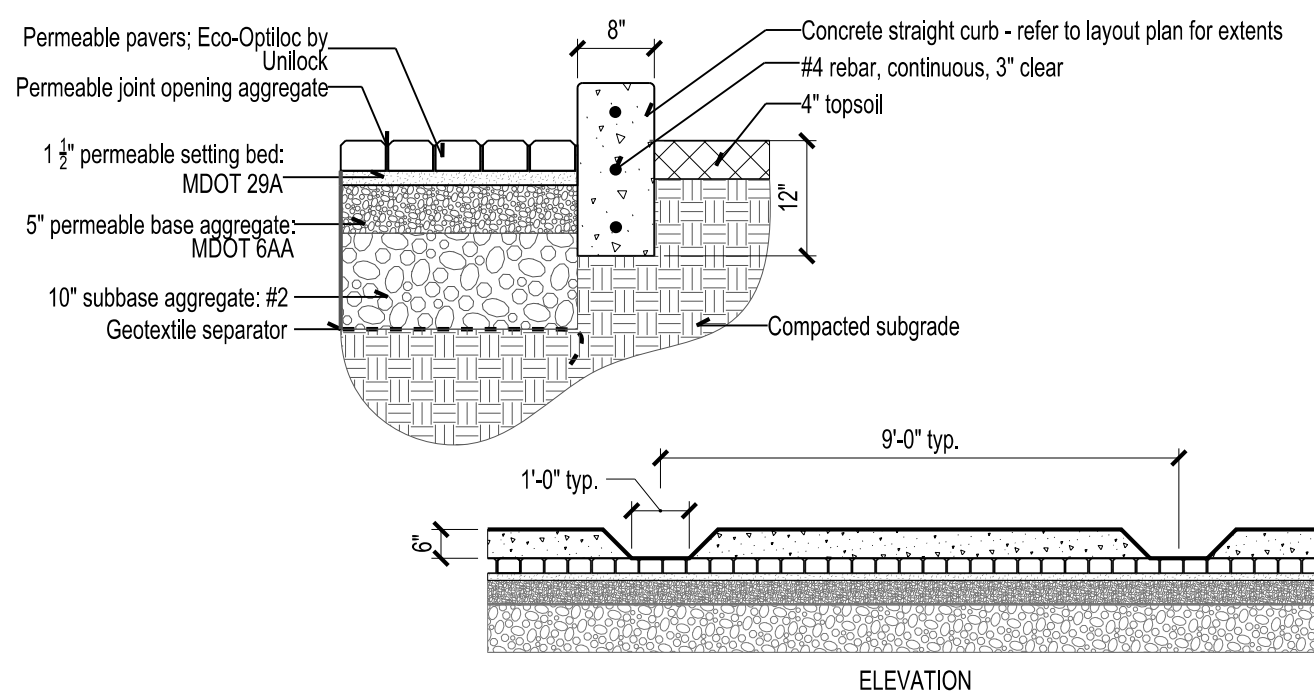

**4 Concrete straight curb with outlets**  
NO SCALE

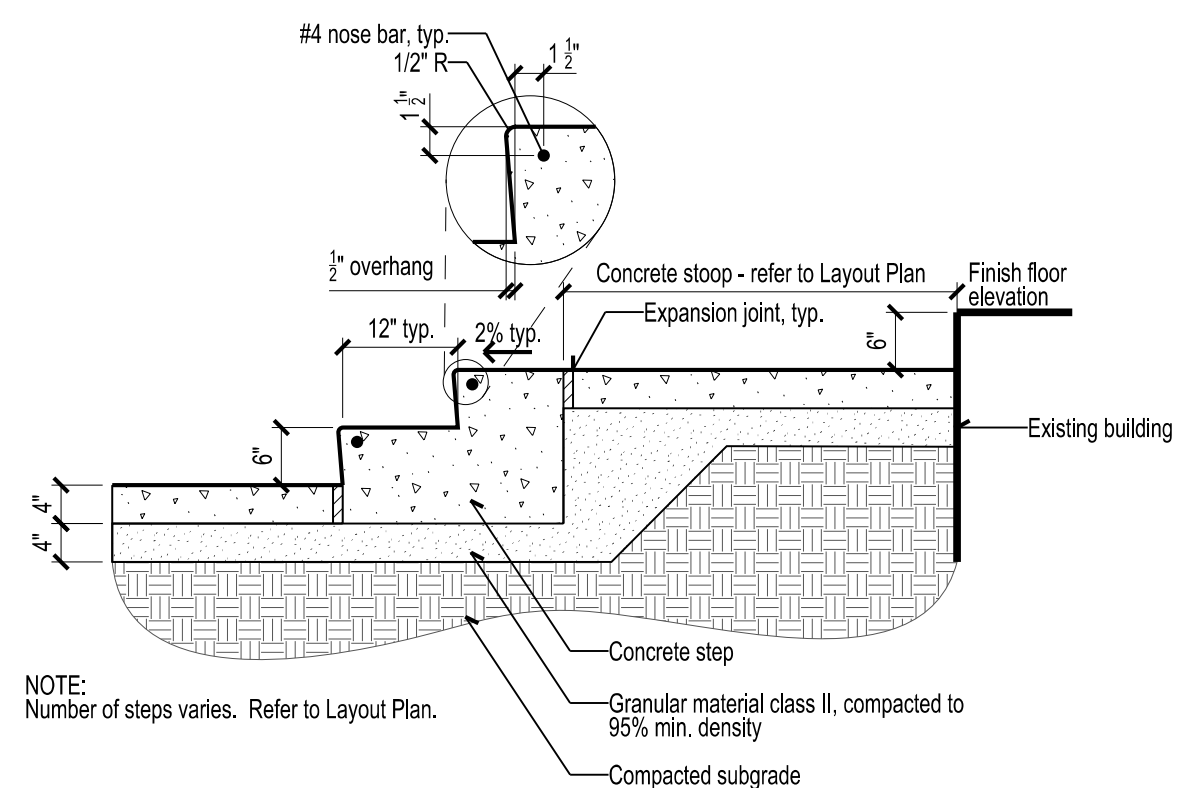

**5 Concrete stoop and steps**  
NO SCALE

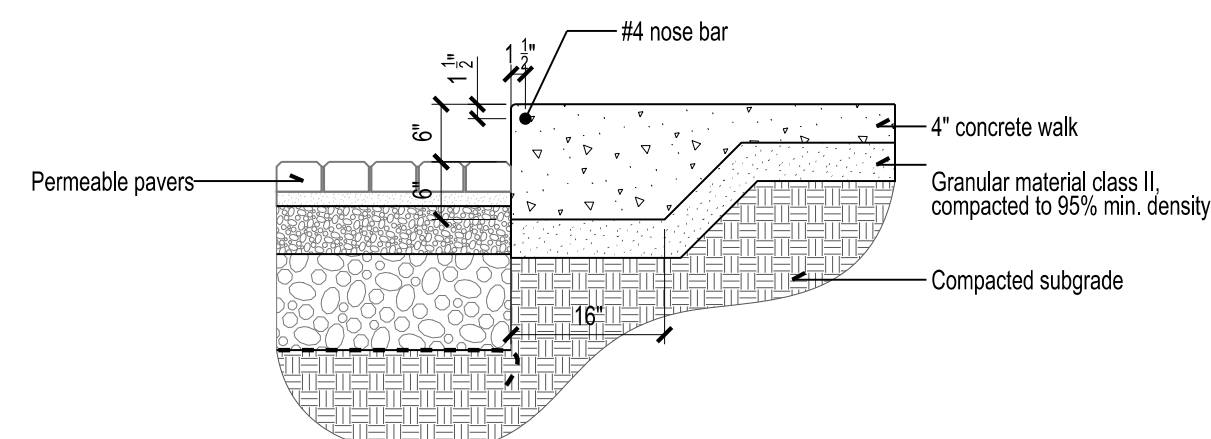

**6 Thickened concrete edge**  
NO SCALE

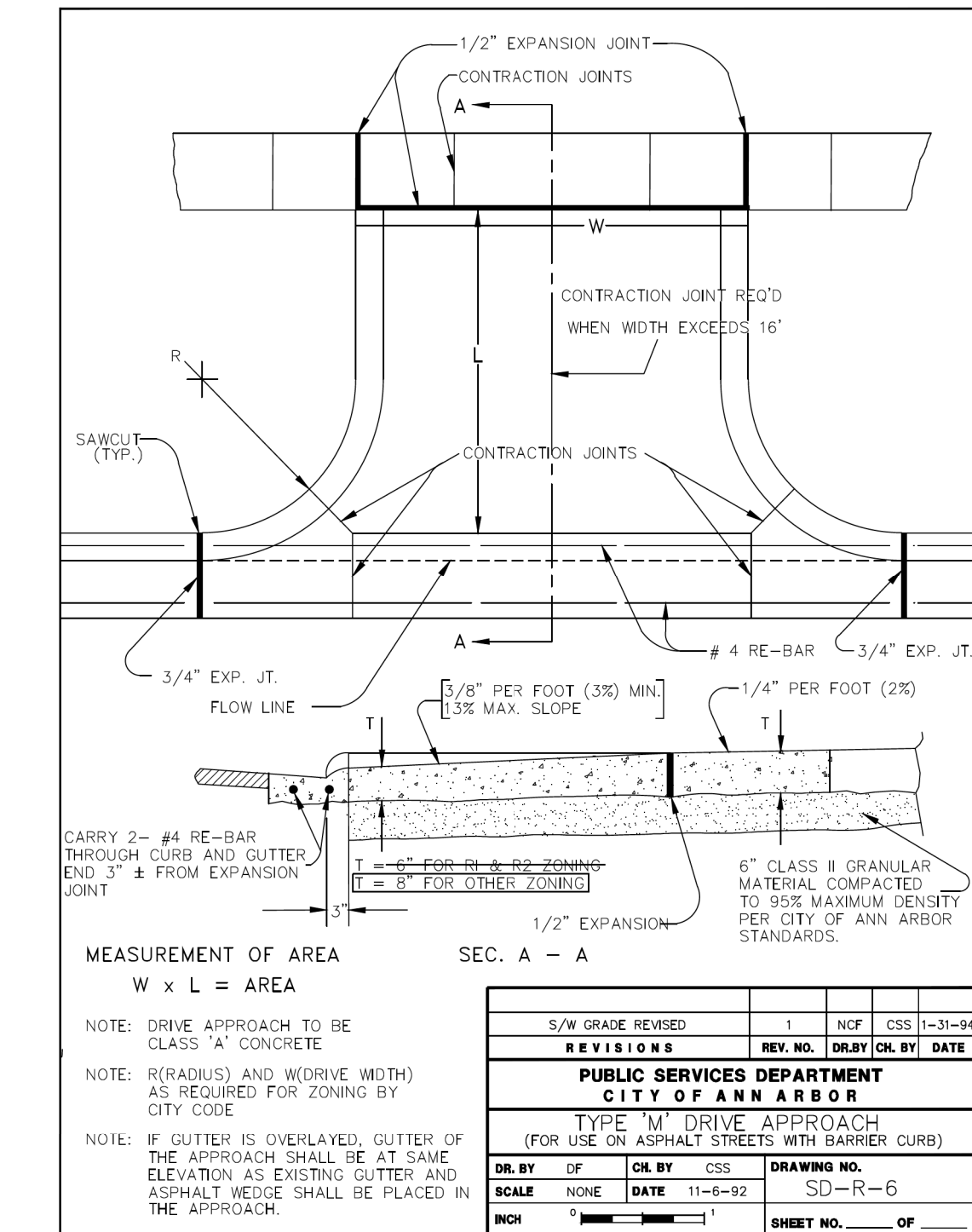

**7 Concrete drive approach**  
NO SCALE

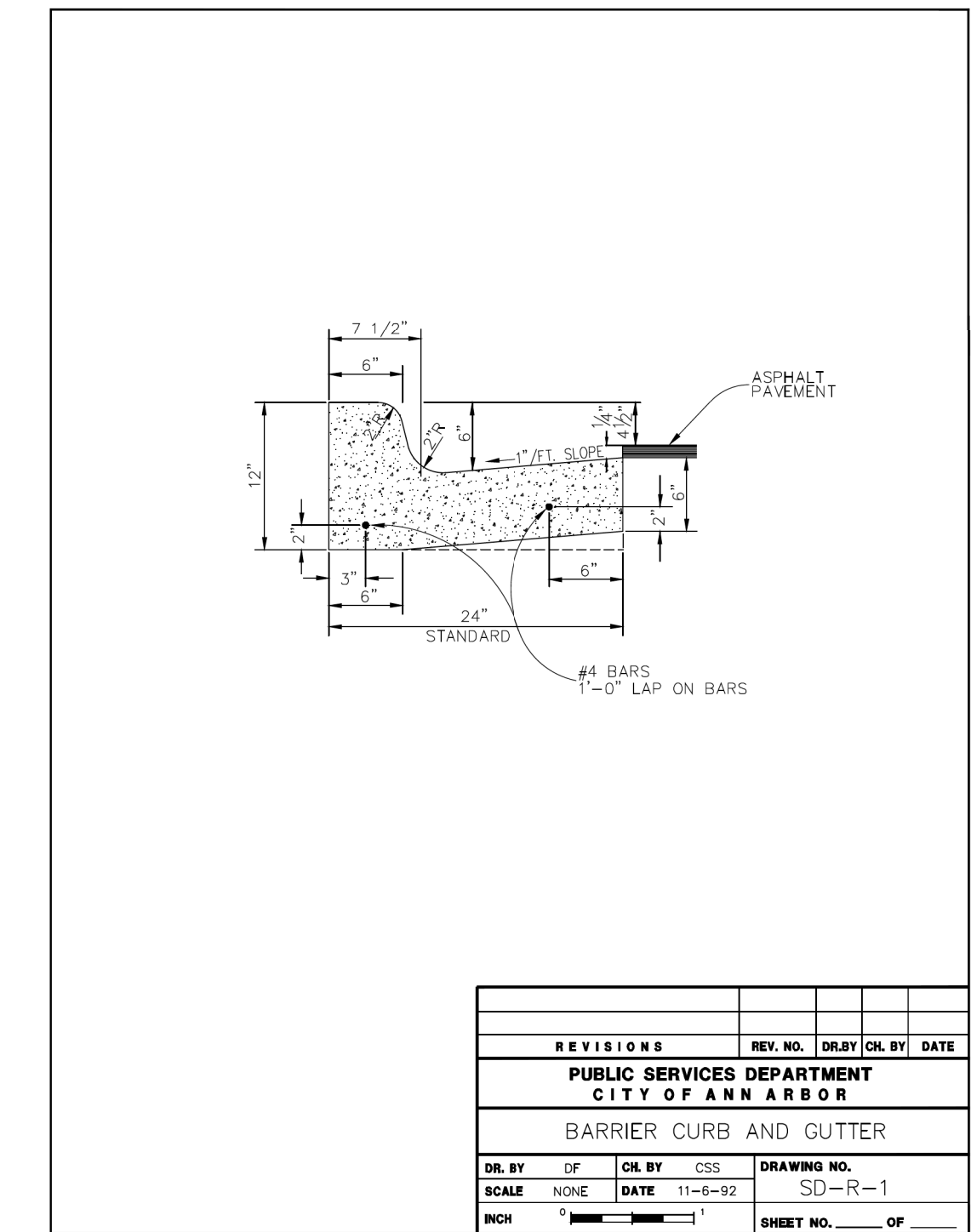

**8 Concrete curb and gutter**  
NO SCALE

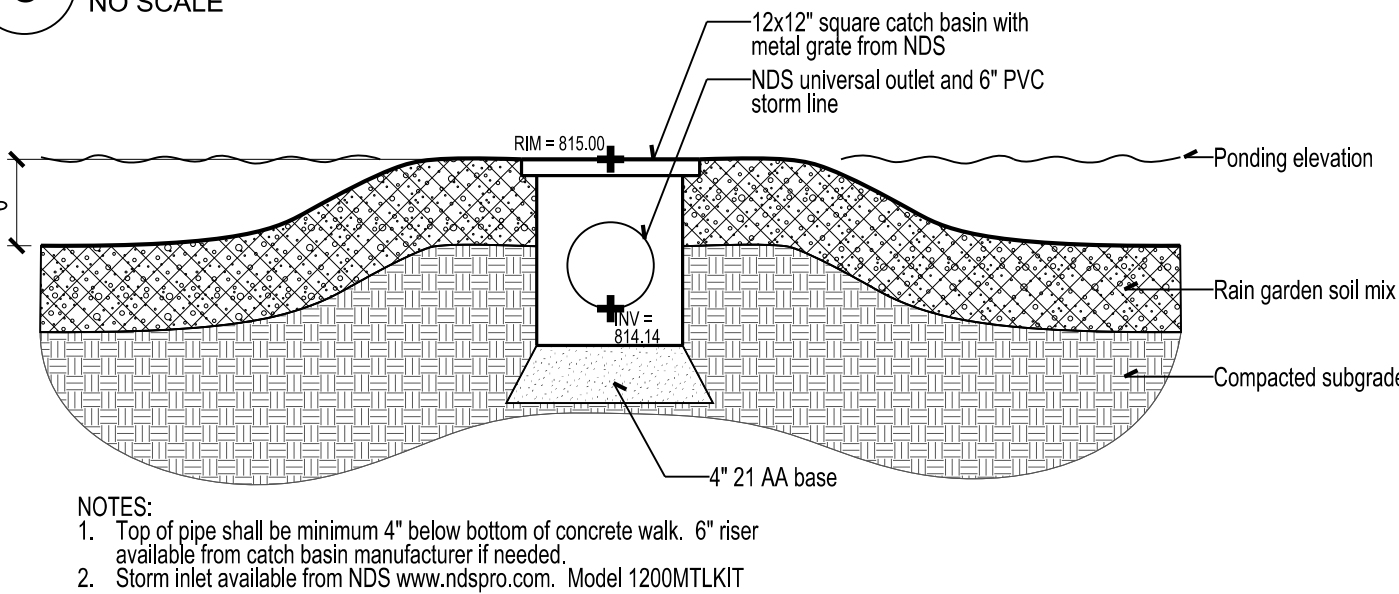

**9 Storm inlet**  
NO SCALE

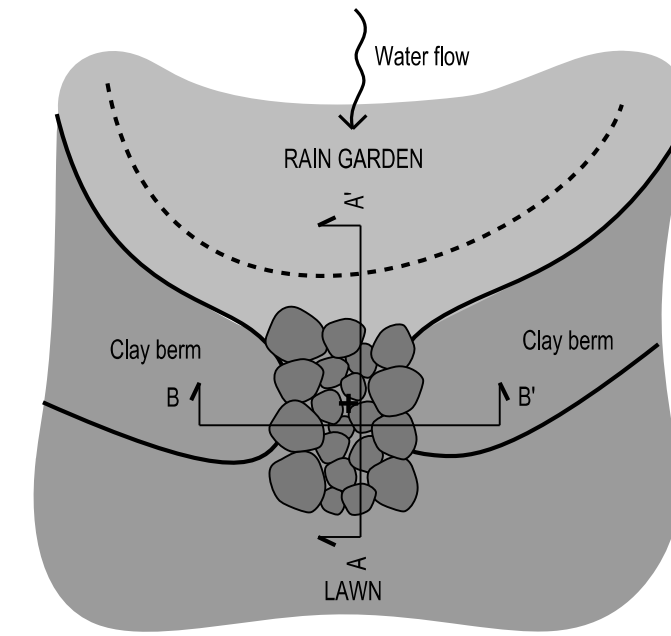

**10 Cobble spillway**  
NO SCALE

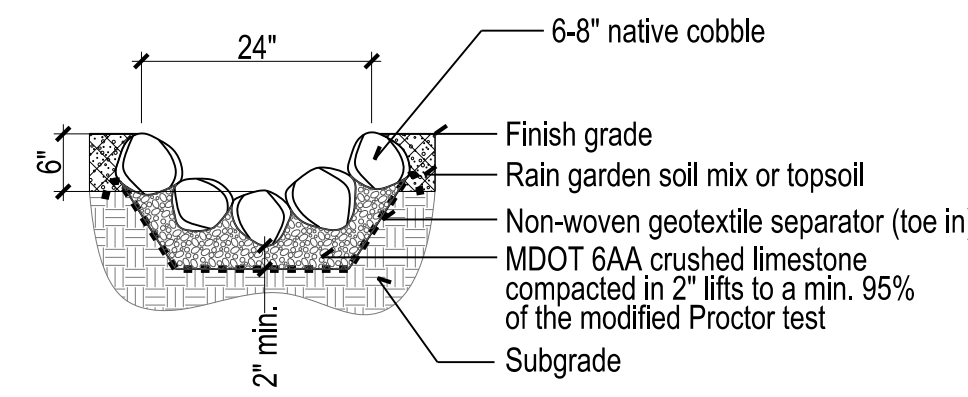

**11 Cobble swale**  
NO SCALE

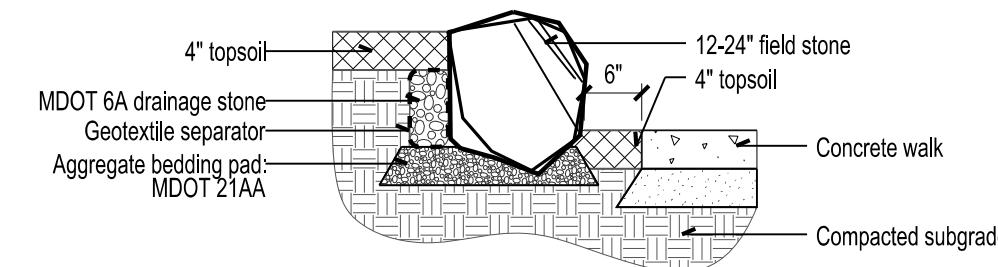

**12 Stone wall**  
NO SCALE

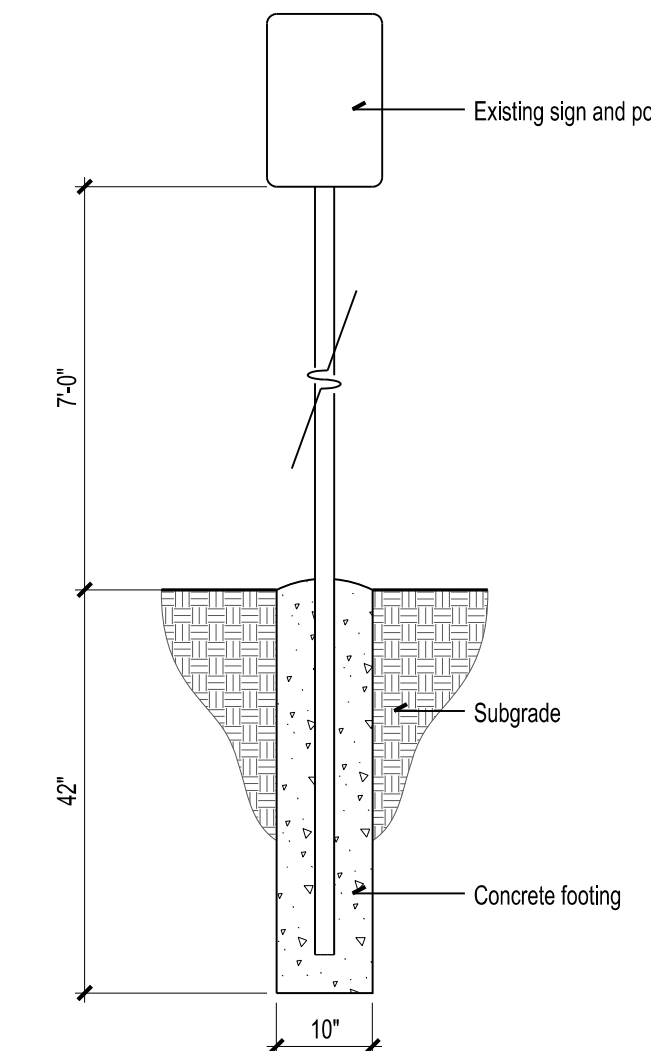

**13 Relocated accessible parking sign**  
NO SCALE

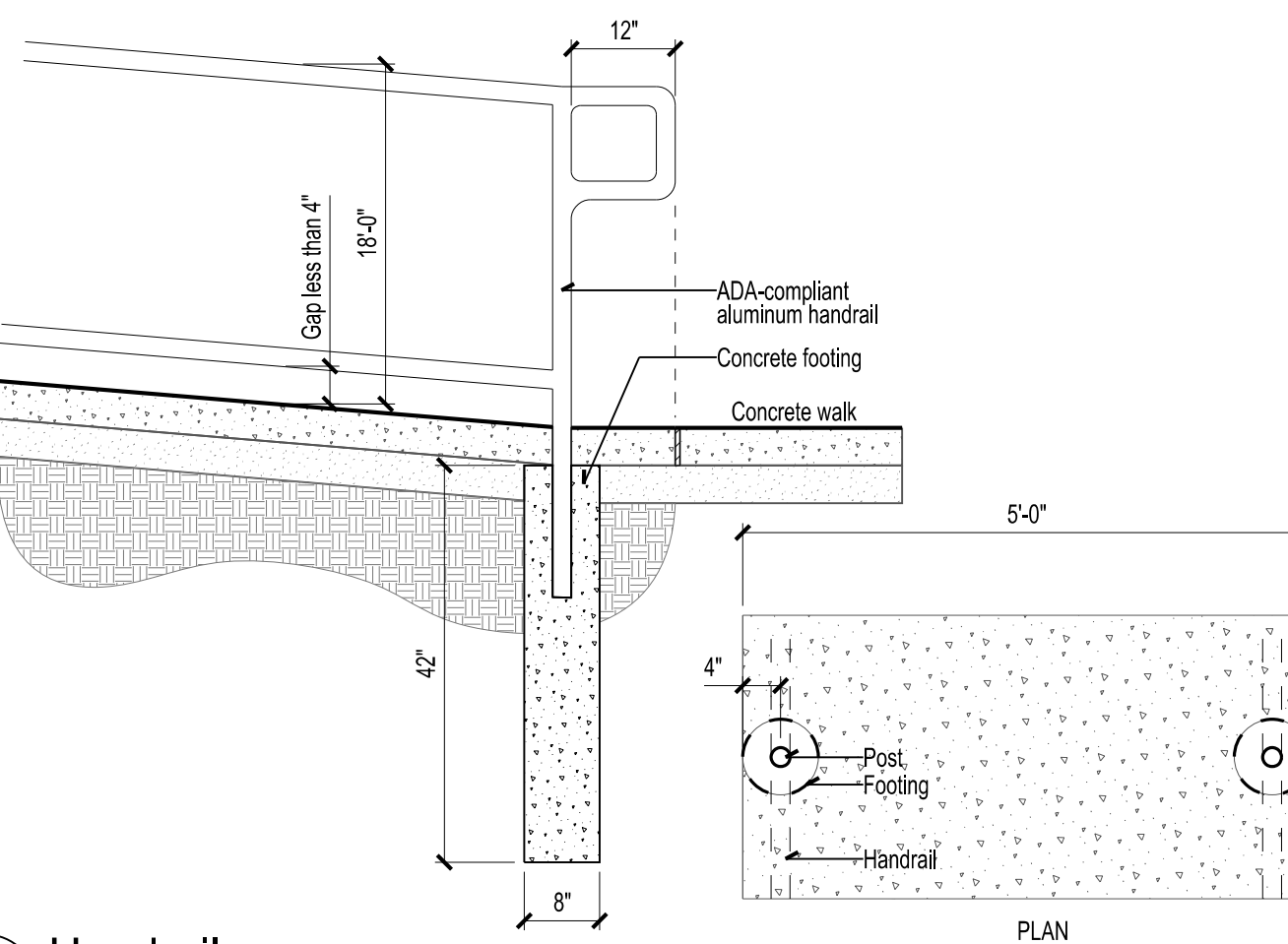

**14 Handrail**  
NO SCALE

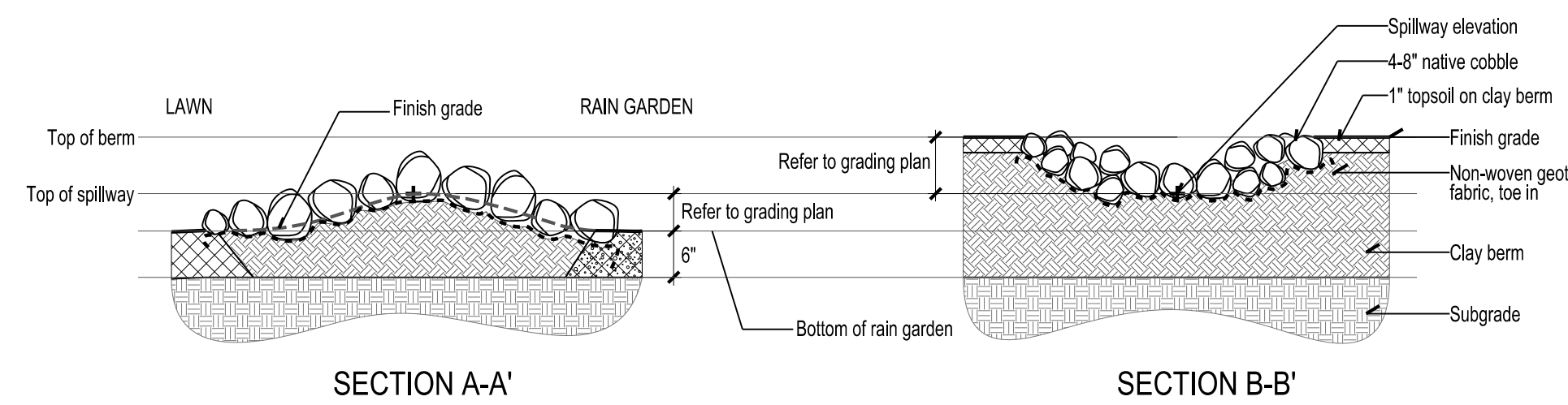

**NOTES:**  
 1. See grading plan for elevations.  
 2. Check all voids with 1-2" stone.  
 3. Clay berm to be composed of clay soil capable of maintaining integrity of berm when filled with water.  
 4. Clay berm to be toppedressed with 1" topsoil; loosen immediately prior to planting.

**15 Tree planting**  
NO SCALE

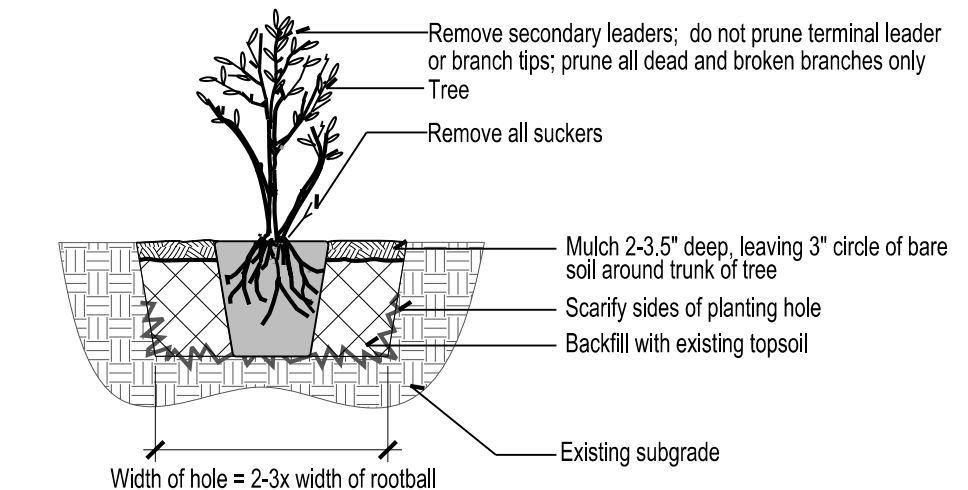

**NOTES:**  
 1. See specifications for all material requirements.  
 2. Hole dug for container stock shall be large enough to gently work planting mix around all sides of plant.  
 3. Spacing per plan.  
 4. Remove container. Set stock at finish grade.  
 5. Container system to be kept moist prior to, during, and after planting.  
 6. Prune dead wood and broken or diseased twigs.  
 7. Topsoil to be 1" deep when located on clay berm, and loosely worked in immediately prior to planting.

**16 Shrub and perennial planting**  
NO SCALE

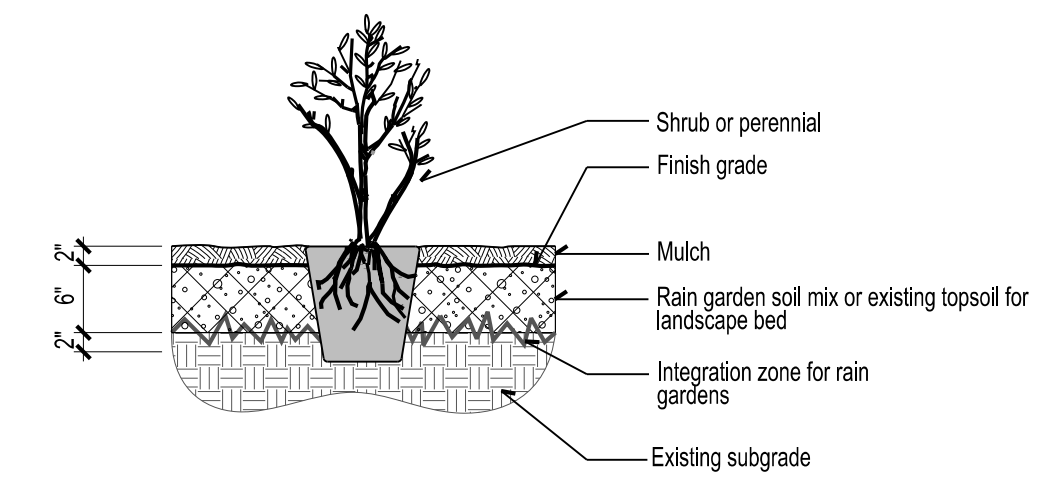

**NOTES:**  
 1. See specifications for all material requirements.  
 2. Hole dug for container stock shall be large enough to gently work planting mix around all sides of plant.  
 3. Spacing per plan.  
 4. Remove container. Set stock at finished grade.  
 5. Container system to be kept moist prior to, during, and after planting.  
 6. Prune dead wood and broken or diseased twigs.  
 7. Topsoil to be 1" deep when located on clay berm, and loosely worked in immediately prior to planting.

**17 Native plug planting**  
NO SCALE

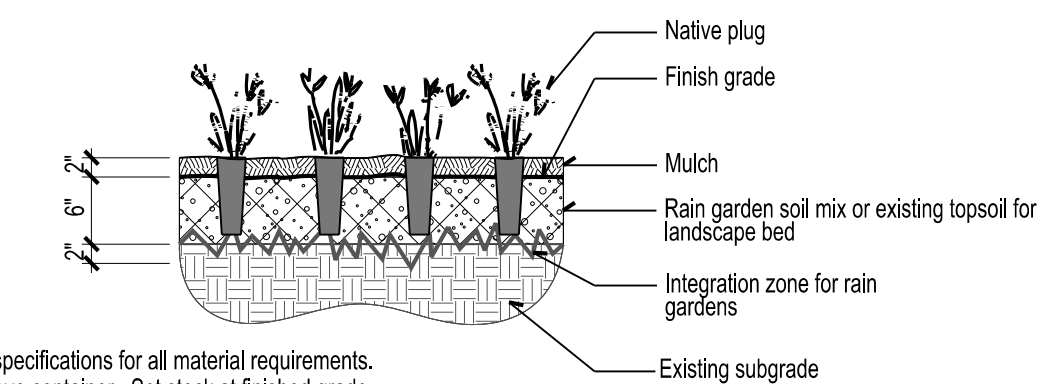

**NOTES:**  
 1. See specifications for all material requirements.  
 2. Remove container. Set stock at finished grade.  
 3. Spacing per plan.  
 4. Topsoil to be 1" deep when located on clay berm.

**18 Rain garden soil mix and landscape bed**  
NO SCALE

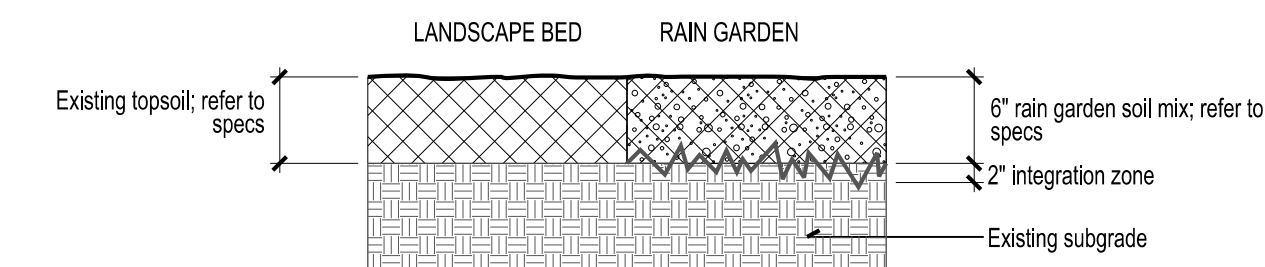

**19 Stepping stone**  
NO SCALE

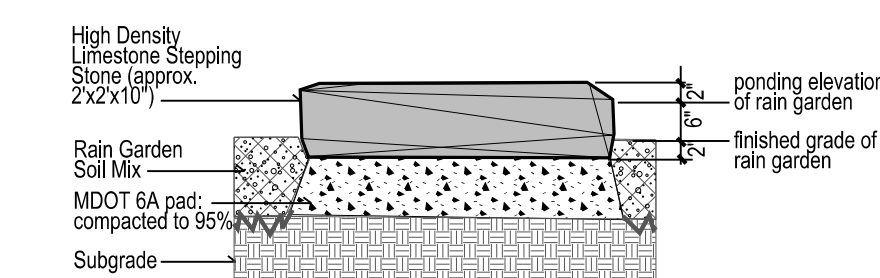

**20 Handrail detail**  
NO SCALE