



CITY OF ANN ARBOR PROJECT MANAGEMENT

OBSERVATORY STREET IMPROVEMENT PROJECT

NOTES

FOR PROTECTION OF UNDERGROUND UTILITIES AND IN CONFORMANCE WITH PUBLIC ACT 53, THE CONTRACTOR SHALL CALL 811 OR 1-800-482-7171 A MINIMUM OF THREE FULL WORKING DAYS, EXCLUDING SATURDAYS, SUNDAYS, AND HOLIDAYS, PRIOR TO BEGINNING EACH EXCAVATION IN AREAS WHERE PUBLIC UTILITIES HAVE NOT BEEN PREVIOUSLY LOCATED. MEMBERS WILL THUS BE ROUTINELY NOTIFIED. THIS DOES NOT RELIEVE THE CONTRACTOR OF THE RESPONSIBILITY OF NOTIFYING UTILITY OWNERS WHO MAY NOT BE A PART OF THE "MISS DIG" ALERT SYSTEM.

THE UNDERGROUND LOCATIONS SHOWN FOR NATURAL GAS, TELEPHONE, ELECTRICAL POWER, CABLE TV AND FIBER OPTIC LINES ARE APPROXIMATE. THE CITY OF ANN ARBOR ASSUMES NO RESPONSIBILITY FOR THEIR ACCURATE REPRESENTATION IN THIS DRAWING. MISS DIG MUST BE CONTACTED PRIOR TO CONSTRUCTION TO LOCATE THESE UTILITIES.

THE CONSTRUCTION COVERED BY THESE PLANS SHALL CONFORM TO THE 1994 EDITION OF THE CITY OF ANN ARBOR PUBLIC SERVICES DEPARTMENT STANDARD SPECIFICATIONS, ITS DETAILS, WHICH ARE INCLUDED BY REFERENCE, AND THIS PROJECT'S CONTRACT DOCUMENTS. THE OMISSION OF ANY CURRENT STANDARD DETAIL DOES NOT RELIEVE THE CONTRACTOR FROM THIS REQUIREMENT.

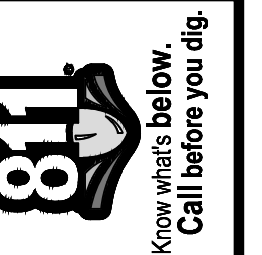

REV.	DESCRIPTION	DATE	DRAWN	CHECKED
02	BID SET	2/09/2016	JKA	IVK
01	U OF M REVIEW	11/05/2015	JKA	IVK
00	PROJECT ENGINEER REVIEW	10/02/2015	JKA	IVK

CITY OF ANN ARBOR
PUBLIC SERVICE
301 EAST HURON STREET
ANN ARBOR, MI 48106-6647
ANN ARBOR 734-794-4410
WWW.A2GOV.ORG

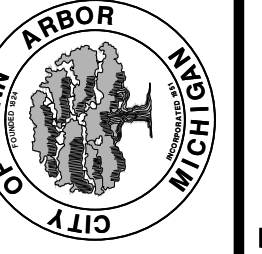

PROJECT MANAGEMENT - PUBLIC SERVICES - CITY OF ANN ARBOR
OBSERVATORY STREET IMPROVEMENT PROJECT
GEDDES AVENUE TO E ANN STREET

SCALE
SHEET No.
DRAWING No.
2015025-1
1 OF 40

© OBSERVATORY STREET IMPROVEMENT PROJECT; BID No. 4425; 2015025

S:\Project Management\Design\2015025 Observatory\Plan Production\2015025COV.dwg - _a2 standard bw.stb - Plot Date: 2/12/2016 11:07:16 AM

SHEET LIST TABLE	
SHEET NUMBER	SHEET TITLE
1	COVER SHEET
2	LEGEND
3	NOTES
4-7	DETAILS
8	PROPOSED TYPICAL SECTIONS
9	OVERALL WATER MAIN PLAN
10-12	DETOUR AND MAINTENANCE OF TRAFFIC
13-15	REMOVALS
16-23	WATER MAIN PLAN & PROFILE
24-30	ROAD PLAN & PROFILE
31-37	INTERSECTION GRADING
38-40	PAVEMENT MARKINGS

BID No. 4425, FILE No. 2015025

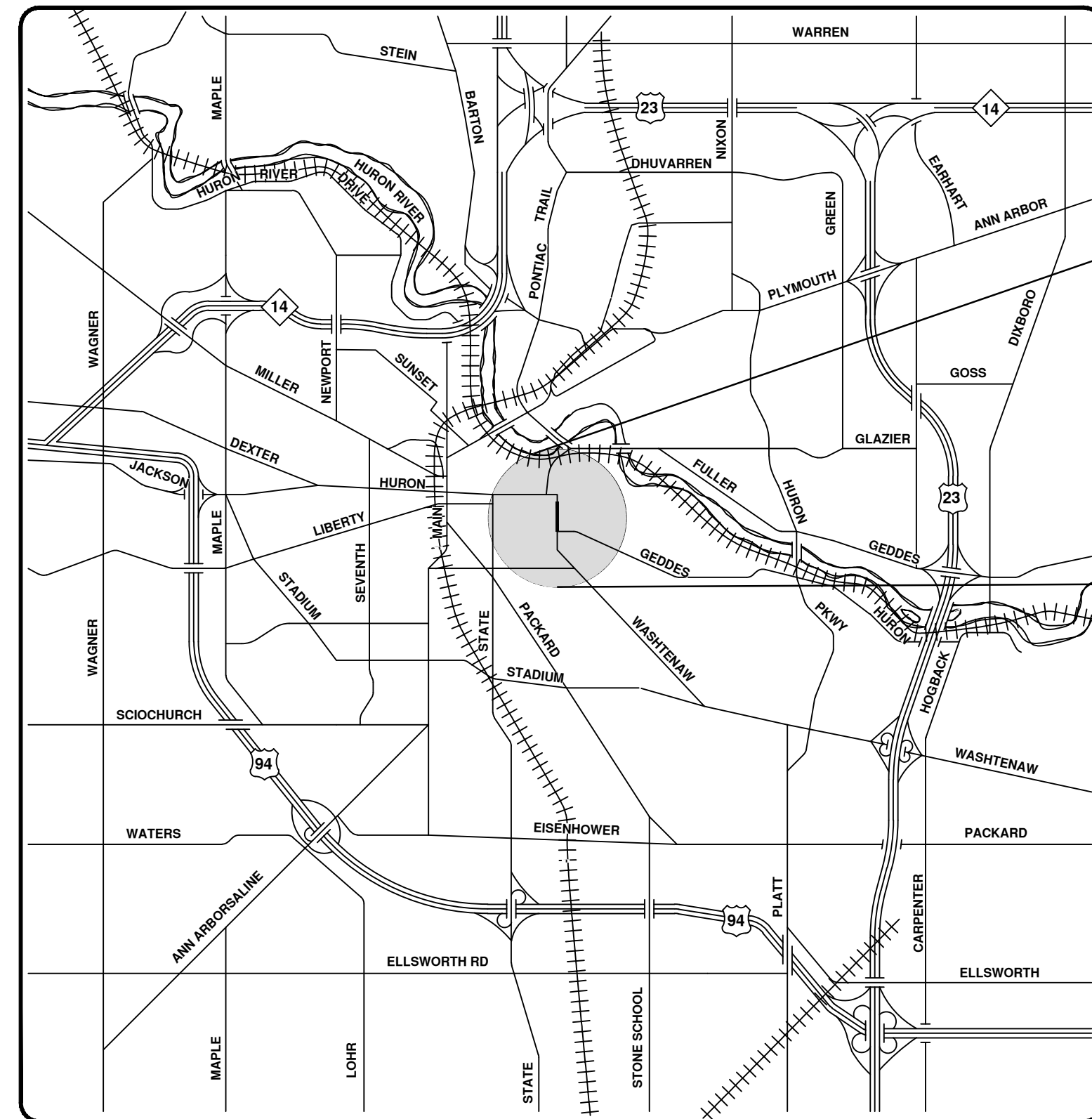
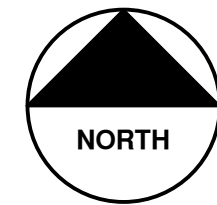

VICINITY MAP

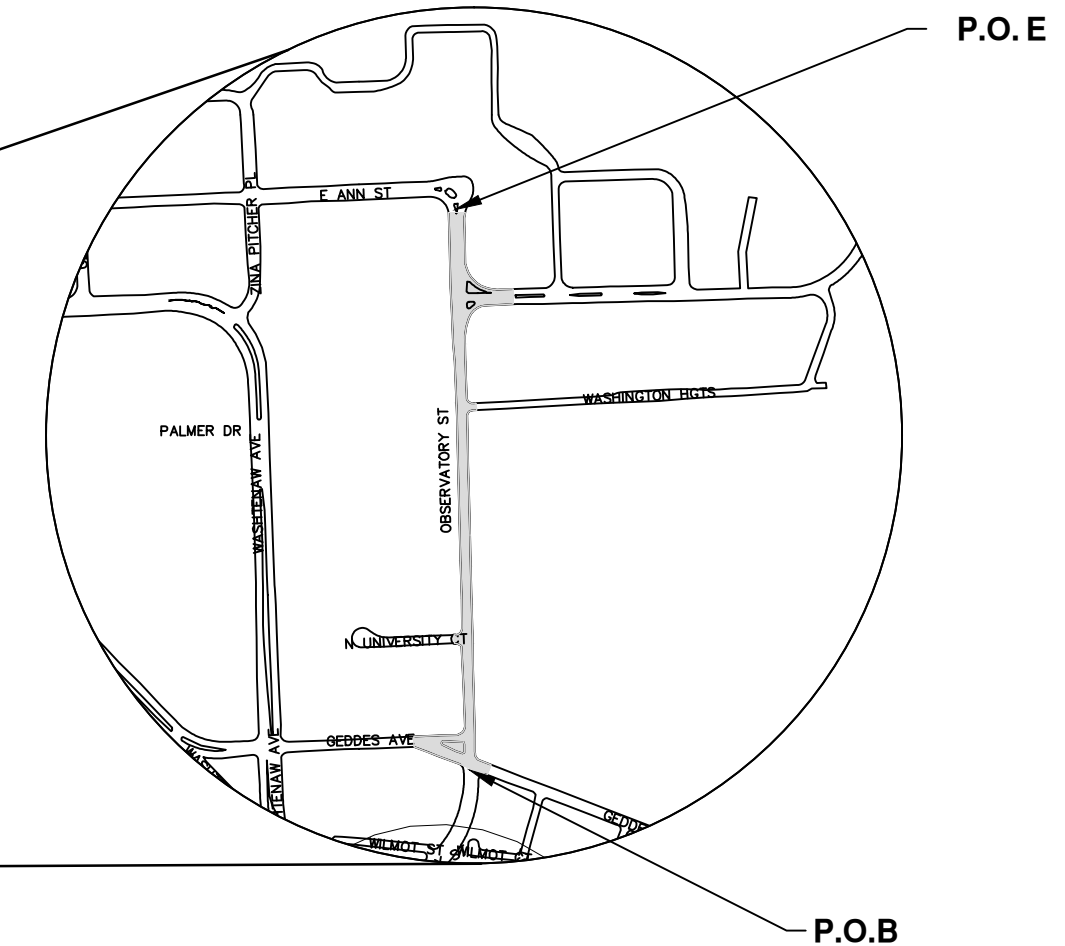

P.O.E

P.O.B

PROJECT MANAGEMENT SERVICE UNIT

PREPARED UNDER THE SUPERVISION OF

Igor V. Kotlyar
IGOR V. KOTLYAR, P.E. - MI LICENSE No. 43287
PROJECT MANAGER

02/09/2016
DATE

EXISTING LEGEND

- ⊕ FIRE HYDRANT
- I GATE VALVE IN BOX
- ⊙ GATE VALVE IN WELL
- ⊙ STOP BOX
- ⊠ WATER VAULT
- ⊙ WELL
- CATCH BASIN (SQ)
- ⊙ CATCH BASIN (RD)
- STORM MANHOLE
- NON-CURB CATCH BASIN (SQ)
-) END SECTION
- SANITARY MANHOLE
- CLEAN-OUT
- POST
- ⊕ PEDESTRIAN SIGNAL
- ⊢ SIGN
- HAND HOLE
- ORNAMENTAL LIGHT
- ⋈ FLOOD LIGHT
- ⊙ UNKNOWN MANHOLE
- ⊙ TELEPHONE MANHOLE
- ⊠ TELEPHONE RISER
- ⊙ GAS VALVE
- GAS VENT
- ⊠ GAS BOX
- ⊠ ELECTRICAL RISER
- ⊠ TRANSFORMER
- ⋈ UTILITY POLE
- LAMP POLE
- ⊢ GUY ANCHOR
- GUY POLE
- ⊙ MONITORING WELL
- ⊠ MAILBOX
- ⊙ SOIL BORING
- △ TRAVERSE POINT
- ⊕ BENCH MARK
- IRON PIPE
- MON BOX

- w --- WATER MAIN
- r --- STORM SEWER
- s --- SANITARY SEWER
- g --- GAS MAIN
- o-v-v-o --- ELECTRICAL OVER HEAD
- v-v-v --- ELECTRICAL UNDER GROUND
- e duct bank --- ELECTRICAL DUCT BANK
- oht --- oht --- TELEPHONE OVER HEAD
- t --- t --- TELEPHONE UNDER GROUND
- t duct bank --- TELEPHONE DUCT BANK
- ohtv --- CABLE TV OVER HEAD
- tv --- CABLE TV UNDER GROUND
- fo --- FIBER OPTIC
- fo duct bank --- FIBER OPTIC DUCT BANK
- BOUNDARY --- BOUNDARY
- /// BUILDING
- --- CENTERLINE OF DITCH
- --- CENTERLINE/CROWN OF ROAD
- 800 --- CONTOUR MAJOR
- 799 --- CONTOUR MINOR
- --- EDGE OF WATER
- ▨ FLOODPLAIN
- // --- FENCE
- --- GRAVEL
- --- GUARDRAIL
- --- STONE WALL
- --- R.O.W.
- --- TREELINE
- --- WETLAND
- --- EDGE OF BRUSH
- --- HEDGE

- TREE (DECIDUOUS)
- TREE (CONIFEROUS)
- SHRUB (DECIDUOUS)
- STUMP
- TREE TO REMAIN & PROTECT (DECIDUOUS)
CRITICAL ROOT ZONE (C.R.Z.) = DIAMETER BREST HEIGHT (INCHES) X 10
- TREE TO REMAIN & PROTECT (CONIFEROUS)
CRITICAL ROOT ZONE (C.R.Z.) = DIAMETER BREST HEIGHT (INCHES) X 10

PROPOSED LEGEND

- ⊕ HYDRANT (PLAN)
- ⊙ WATER GATE WELL
- ▽ REDUCER
- ⊢ WATER GATE VALVE
- ⊙ WATER STOP BOX
- ⊠ WATER VAULT
- ⊙ INLET
- ⊠ DOUBLE INLET
- ⊙ INLET JUNCTION CHAMBER
- ⊙ ROUND CATCH BASIN
- ⊙ STORM MANHOLE
- ⊢ DRAIN ARROW
- ⊠ FLARED END SECTION
- ⊙ SANITARY MANHOLE
- CLEAN-OUT
- BARREL
- ⊢ SIGN
- PUSH BUTTON
- ⊠ HAND HOLE
- w --- WATER MAIN
- r --- STORM SEWER
- s --- SANITARY SEWER
- FO --- FIBER OPTIC
- E --- ELECTRICAL
- --- CENTERLINE OF DITCH
- --- CENTERLINE OF ROAD
- // --- FENCE
- --- GRAVEL
- --- SILT FENCE
- --- PROTECTIVE FENCE
- --- LOT/UNIT
- --- GUARDRAIL
- --- FLARED END SECTION
- --- CURB
- --- TEMPORARY GRADING PERMIT
- 800 --- CONTOUR MAJOR
- 799 --- CONTOUR MINOR
- --- WATER EASMENT
- --- STORM EASEMENT
- --- SANITARY EASEMENT
- --- R.O.W.
- --- LIMITS OF CONSTRUCTION
- --- LIMIT OF GRADING
- --- STONE WALL

- ▨ DETECTABLE WARNING
- ▨ ASPHALT
- ▨ CONCRETE
- ▨ SIDEWALK
- TREE (DECIDUOUS)
- TREE (CONIFEROUS)
- TREE TO BE REMOVED (DECIDUOUS)
- TREE TO BE REMOVED (CONIFEROUS)
- STUMP TO BE REMOVED



Know what's below.
Call before you dig.

	IVK	IVK	IVK	IVK	IVK	IVK	IVK	IVK	CHECKED
	JKA	JKA	JKA	JKA	JKA	JKA	JKA	JKA	DRAWN
	2/09/2016	11/05/2015	10/02/2015	DATE					
	BID SET	U OF M REVIEW	PROJECT ENGINEER REVIEW	REV.					
	02	01	00						



CITY OF ANN ARBOR
PUBLIC SERVICES
301 EAST HURON STREET
ANN ARBOR, MI 48106-0667
www.a2gov.org

PROJECT MANAGEMENT - PUBLIC SERVICES - CITY OF ANN ARBOR
OBSERVATORY STREET IMPROVEMENT PROJECT
LEGEND

SCALE PLAN: N/A

DRAWING No. **2015025-2**

SHEET No. **2 OF 40**

S:\Project Management\Design\2015025 Observatory\Plan Production\2015025COV.dwg - _a2 standard bw.stb - Plot Date: 2/12/2016 11:07:18 AM

CONSTRUCTION NOTES:

1. Driveways and entrances to buildings, real property, and the like shall not be blocked except for short durations and only when approved by the Engineer. Vehicular and pedestrian access shall be maintained at all times. It shall be the Contractor's responsibility to coordinate all necessary driveway closures with the property owner(s) and resident(s) in the areas of construction.
2. The location and depth of all existing utilities and service leads are to be field verified by the Contractor prior to construction.
3. Location and depth of utilities as depicted on the plans is approximate and shown according to the best information available. It is the Contractor's responsibility to excavate ahead and adjust depth of conflict utilities accordingly. Any damage to utilities is the Contractor's responsibility to avoid and/or repair as necessary.
4. The Contractor is to take special care to protect the existing water main and be responsible for maintaining consistent water service.
5. During non-working hours no trench shall remain open; any open trench shall be properly secured with protective fencing. This work shall be included in the item of work "General Conditions".
6. Trenches for new water services shall be excavated to MIOSHA and City of Ann Arbor Field Services requirements.
7. City of Ann Arbor Field Services will install the corporation and copper service lead(s) to transfer the connection(s). If an existing water service is found to be failing or is not copper, the lead will be replaced to the curb box by Field Services.
8. For the installation of corporations, or any other related activities, the Contractor shall not receive additional compensation for delays due to the scheduling of or coordination with the City of Ann Arbor Field Services.
9. The Contractor shall backfill trenches in accordance with Trench Detail specified on plans. This work shall be included in the item of work "Excavate and Backfill for Water Service Tap and Lead". All concrete removals and replacements required for this work will be paid for separately.
10. All ductile iron pipe and fittings shall be polyethylene wrapped per ANSI/AWWA C105/A21.5.
11. Cor-blu bolts to be used at all mechanical water main joints at hydrants and Megalug fittings
12. The Contractor shall construct, flush, and bacteriologically test the water main per Detailed Specification "Water Main Installation and Testing" and as approved by the Engineer. All chlorinated water shall be discharged directly into an approved sanitary sewer. The Contractor shall supply all necessary hoses, fittings and the like to accomplish this work.
13. Water main fittings, other than those specifically listed as separate pay items, which are required to complete the work, such as blow-off assemblies, concrete thrust blocks, solid sleeves and mechanical plugs, shall not be paid for separately, but shall be included in the pipe pay items.
14. "No Parking" signs shall be installed by the Contractor at locations as approved or directed by the Engineer. All signs shall be installed in accordance with the detailed specifications.

15. Postal delivery and refuse pickup service shall be maintained at all times by the Contractor.
16. All fittings, hydrants, valves and castings removed during construction are the property of the City of Ann Arbor. The Contractor within 48 hours shall deliver to City of Ann Arbor Field Operations and Maintenance Facility at the W.R. Wheeler Service Center located at 4251 Stone School Road.
17. Where street curbs are undermined due to construction activities, they shall be removed and replaced as directed by the Engineer.
18. The Contractor shall be responsible for the continuous maintenance of the temporary road surface and soil erosion control measures within the construction area until the full completion of the project. This work shall be included in the item of work "General Conditions".
19. All curb, sidewalk, driveway approach removals shall be approved by Engineer before the work is done.
20. Sawed sewer pipe connections shall be coupled with a Fernco flexible coupling and a stainless steel shear ring.
21. The location of material stock piles and on-site staging areas to be approved by the Engineer.
22. For mainline paving, the width of the mat for each pass of the paver shall be not less than 10.5' or greater than 15', as directed by the Engineer. The Engineer will direct the layout of the longitudinal joints during construction.
23. All structures shall receive new castings as directed by the Engineer, as specified on the standard casting schedule. The existing castings are the property of the City of Ann Arbor. The Contractor shall deliver to City of Ann Arbor Field Operations and Maintenance Facility at the W.R. Wheeler Service Center located at 4251 Stone School Road.
24. Payment for drainage structure sumps, where specified, shall be included in the payment for the various drainage structure sizes and or types.
25. Where sewer pipes of different sizes or materials are joined, Fernco flexible couplings with stainless steel shear rings shall be used. The Contractor's purchase price for these devices, including shipping, shall be paid as an extra. Prior to payment for this item, the Contractor shall submit receipts for the Engineer's review and approval. All other costs associated with the installation of these devices shall be included in the payment for the sewer.
26. Where sewer and water main are to be removed & replaced or added, all pipe shall be installed using Trench Detail detailed in the specifications or shown on Plans. Backfill for sewer and water construction shall be MDOT Granular Material, Class II, Modified.
27. Existing street name, guide, and regulatory signs, and mailboxes which conflict with the proposed construction shall be removed prior to construction, stored in a manner which will prevent damage, and re-set in locations as directed by the Engineer. This work will not be paid for separately, but shall be included in "Machine Grading, Modified"
28. In areas where edge drain cannot be installed in accordance with City of Ann Arbor Detail SD-TD-11, the edge drain shall be installed at the depth as indicated on the plans, or as directed by Engineer. In no case shall the edge drain be installed at a grade less than 0.50% or at a depth of less than 2' below top of proposed pavement.

SOIL EROSION & SEDIMENT CONTROL GENERAL NOTES:

NOTIFY THE CITY OF ANN ARBOR SOIL EROSION CONTROL OFFICE 48 HOURS PRIOR TO BEGINNING WORK ON THE PROJECT. PHONE: 734-794-6265.

1. THE CONTRACTOR SHALL IMPLEMENT AND MAINTAIN SOIL EROSION CONTROL MEASURES AS DIRECTED BY THE ENGINEER AT ALL TIMES DURING CONSTRUCTION. ANY MODIFICATIONS OR ADDITIONS TO THE SOIL EROSION CONTROL MEASURES DUE TO CONSTRUCTION OR CHANGED CONDITIONS SHALL BE AS DIRECTED AND APPROVED BY THE ENGINEER.
2. ALL SOIL EROSION AND SEDIMENTATION CONTROL WORK SHALL CONFORM TO THE PERMIT REQUIREMENTS OF THE CITY OF ANN ARBOR, CITY ORDINANCE CHAPTER 63, CITY OF ANN ARBOR STANDARDS DIVISION VII, THE LAWS OF THE STATE OF MICHIGAN, AND THE REQUIREMENTS OF THE CONTRACT DOCUMENTS.
3. DAILY, OR AFTER ANY STORM EVENT, INSPECTIONS OF EROSION CONTROL MEASURES SHALL BE MADE BY THE CONTRACTOR. PERIODIC INSPECTIONS MAY BE MADE BY THE ENGINEER TO DETERMINE THE EFFECTIVENESS OF EROSION AND SEDIMENTATION CONTROL MEASURES. ANY NECESSARY CORRECTIONS SHALL BE MADE WITHOUT DELAY, AND WITHOUT ADDITIONAL COST TO THE CITY OF ANN ARBOR.
4. EROSION AND SEDIMENTATION FROM WORK ON THE SITE SHALL BE CONTAINED ON THE SITE AND NOT BE ALLOWED TO COLLECT ON ANY OFF-SITE AREAS, ROADWAYS OR WATERWAYS.
5. ALL MUD/DIRT TRACKED ONTO ROADWAYS FROM THE SITE DUE TO CONSTRUCTION, SHALL BE PROMPTLY REMOVED BY THE CONTRACTOR. IF SO ORDERED, THE CONTRACTOR SHALL PROVIDE AND OPERATE A VACUUM-TYPE STREET SWEEPER, AT NO ADDITIONAL COST TO THE CITY OF ANN ARBOR, WITHIN FOUR (4) HOURS OF BEING SO ORDERED.
6. RESTORATION OF ALL DISTURBED AREAS, INCLUDING PLACEMENT OF TOPSOIL, SEED, FERTILIZER AND MULCH AND/OR SOD SHALL BE PERFORMED WITHIN FIVE (5) DAYS OF THE COMPLETION OF FINAL GRADE.
7. CONSTRUCTION OPERATIONS SHALL BE SCHEDULED AND PERFORMED SO THAT PREVENTATIVE SOIL EROSION CONTROL MEASURES ARE IN PLACE PRIOR TO EXCAVATION IN CRITICAL AREAS AND TEMPORARY STABILIZATION MEASURES ARE IN PLACE IMMEDIATELY FOLLOWING BACKFILLING OPERATIONS.
8. SPECIAL PRECAUTIONS WILL BE TAKEN IN THE USE OF CONSTRUCTION EQUIPMENT TO PREVENT SITUATIONS THAT PROMOTE EROSION.
9. PROPER DUST CONTROL SHALL BE MAINTAINED DURING CONSTRUCTION BY USE OF WATER TRUCKS AND/OR DUST PALLATIVE AS REQUIRED.
10. THE CONTRACTOR SHALL BE RESPONSIBLE FOR MAINTAINING ALL TEMPORARY SOIL EROSION CONTROL MEASURES AND REMOVAL OF SOME MEASURES UPON AUTHORIZED COMPLETION OF THE PROJECT. FINAL COMPLETION OF PROJECT WILL NOT BE AUTHORIZED UNTIL ALL SITE WORK AND UTILITY CONSTRUCTION IS COMPLETE AND ALL SOILS ARE STABILIZED.
11. THE CONTRACTOR SHALL NOT GRADE INTO ADJACENT PROPERTIES. SILT AND PROTECTIVE FENCE SHALL BE INSTALLED AND MAINTAINED TO PREVENT GRADING, EROSION AND SEDIMENTATION INTO THE ADJACENT PROPERTIES.
12. TREE PROTECTION FENCING MUST REMAIN INTACT UNTIL RESTORATION OF THE SITE IS COMPLETE.

SEQUENCE OF EROSION CONTROL MEASURES:

1. THE CONTRACTOR IS TO SUBMIT TO THE ENGINEER, A SEQUENCE OF CONSTRUCTION WITH RESPECT TO THE SOIL EROSION CONTROL MEASURES FOR REVIEW, COMMENT AND APPROVAL. THIS SCHEDULE IS TO INCLUDE INSPECTION AND REPAIR OF ALL TEMPORARY EROSION CONTROL MEASURES DAILY AND WITHIN 24 HOURS OF A STORM EVENT.

SAMPLE SOIL EROSION AND SEDIMENTATION CONTROL INSTALLATION MINIMUM REQUIREMENTS:

- 1.1. INSTALL SILT FENCE, TREE PROTECTION FENCING, AND INLET FILTERS ON EXISTING DRAINAGE FEATURES PRIOR TO ANY CLEARING OR EARTH MOVING OPERATION.
- 1.2. STRIP AND STOCKPILE TOPSOIL. STABILIZE STOCKPILE AS REQUIRED.
- 1.3. INSTALL WATER MAINS, STORM AND SANITARY SEWERS, AND OTHER ENCLOSED DRAINAGE FEATURES. NEW INLET FILTERS SHALL BE INSTALLED IMMEDIATELY FOLLOWING INSTALLATION OF NEW DRAINAGE INLETS.
- 1.4. PERFORM MACHINE GRADING OPERATIONS AND CONSTRUCT PAVEMENTS (MAINLINE, SIDEWALKS, DRIVES, ETC.).
- 1.5. CONTINUALLY MAINTAIN EROSION AND SEDIMENTATION CONTROL MEASURES, AS REQUIRED TO ALLOW DRAINAGE AND SEDIMENT REMOVAL. REMOVE ANY ACCUMULATED SEDIMENT IMMEDIATELY.
- 1.6. COMPLETE ALL GRADING AND FINE GRADING.
- 1.7. TEMPORARY SEED AND INSTALL EROSION CONTROL BLANKET IN ALL DISTURBED AREAS.
- 1.8. CLEAN OUT STORM SEWER SYSTEMS.
- 1.9. REMOVE ALL TEMPORARY SOIL EROSION CONTROL MEASURES UPON FINAL INSPECTION AND APPROVAL BY THE ENGINEER.
- 1.10. REMEDY ANY NOTED DEFECTS TO THE SATISFACTION OF THE CITY OF ANN ARBOR'S SOIL EROSION AND SEDIMENTATION CONTROL OFFICIAL.

NOTE: THIS SEQUENCE IS FOR INFORMATION ONLY. IT IS INTENDED TO SHOW THE SEQUENCE OF CONSTRUCTION WITH RESPECT TO THE SOIL EROSION AND SEDIMENTATION CONTROL MEASURES. THE CONTRACTOR IS RESPONSIBLE FOR SUBMITTING THEIR OWN DETAILED CONSTRUCTION SEQUENCE AND SCHEDULE TO THE ENGINEER FOR REVIEW, COMMENT, AND APPROVAL.

TEMPORARY SEEDING:

1. SEED IN ACCORDANCE WITH PROJECT DRAWINGS AND SPECIFICATIONS.
2. ANY DISTURBED AREA NOT PAVED, SEEDED, MULCHED, SODDED OR BUILT UPON BY NOVEMBER 15TH OR JUNE 30TH IS TO BE TEMPORARILY STABILIZED PER SPECIFICATIONS.

PERMITS REQUIRED TO BE OBTAINED BY THE CONTRACTOR PRIOR TO THE BEGINNING OF CONSTRUCTION.

PERMIT	ISSUING AUTHORITY
LANE CLOSURE PERMIT*	CITY OF ANN ARBOR PROJECT MANAGEMENT UNIT
"NO PARKING" SIGNS PERMIT*	CITY OF ANN ARBOR PROJECT MANAGEMENT UNIT
GRADING/SOIL EROSION & SEDIMENTATION CONTROL PERMIT*	CITY OF ANN ARBOR CUSTOMER SERVICE
RIGHT-OF-WAY PERMIT*	CITY OF ANN ARBOR CUSTOMER SERVICE
* NO COST TO CONTRACTOR	

PERMITS REQUIRED TO BE OBTAINED BY THE CITY OF ANN ARBOR PRIOR TO THE BEGINNING OF CONSTRUCTION.

PERMIT	ISSUING AUTHORITY
M.D.E.Q. WATER MAIN CONSTRUCTION PERMIT	MICHIGAN DEPARTMENT OF ENVIRONMENTAL QUALITY
M.D.E.Q. SANITARY SEWER CONSTRUCTION PERMIT	MICHIGAN DEPARTMENT OF ENVIRONMENTAL QUALITY

CONTACT INFORMATION

PUBLIC UTILITIES	OWNER	CONTACT
WATER		DAN WOODEN (734) 794-6350
SANITARY		MARK COZART (734) 794-6350
STORM	CITY OF ANN ARBOR FIELD OPERATIONS SERVICE UNIT W.R. WHEELER SERVICE CENTER 4251 STONE SCHOOL ROAD ANN ARBOR, MI 48108	MATT WALDSMITH (734) 794-6350
FORESTRY		STEVEN GOEBEL (734) 794-6350
SIGNS SIGNALS STREET LIGHTS		CHUCK FOJTIK (734) 794-6361
PRIVATE UTILITIES	OWNER	CONTACT
GAS	DTE ENERGY 3150 E. MICHIGAN AVE, YPSILANTI TOWNSHIP, MI 48198	ROBERT CZAPIEWSKI (734) 544-7818
ELECTRIC	DTE ENERGY WESTERN WAYNE SERVICE CENTER 8001 HAGGERTY ROAD BELLEVILLE, MI 48111	CLAY COMBEE (734) 397-4112
CABLE	COMCAST 27800 FRANKLIN ROAD SOUTHFIELD, MI 48034	RON SUTHERLAND (313) 999-8300
PHONE	AT&T 550 S. MAPLE ROAD ANN ARBOR, MI 48103	(734) 996-2135
FIBER OPTIC	MCI 2800 N. GLENFILLE ROAD RICHARDSON, TX 75082	DEAN BOYERS (972) 729-6016

BM #	ELEV	DESCRIPTION
2001	903.83	WARNING DO NOT DISTURB. THE CONTRACTOR IS RESPONSIBLE TO LOCATE THIS MONUMENT AND TAKE PRECAUTION PRIOR TO PERFORMING WORK NEAR IT. VERTICAL CONTROL POINT DESCRIBED AS THE 1993 EDITION OF THE CITY OF ANN ARBOR BRASS DISC SET IN CONCRETE AND IS FLUSH WITH THE GROUND. LOCATED IN TRAFFIC ISLAND AT OBSERVATORY AND GEDDES. LOCATED 0.62' SOUTH OF THE BACK OF 3.0' CONCRETE WALK ALONG THE NORTHERLY SIDE OF SAID TRAFFIC ISLAND AND 0.95' WESTERLY OF THE WESTERLY EDGE OF THE 12.5' CONCRETE WALK ALONG THE EASTERLY SIDE OF SAID TRAFFIC ISLAND.
16	901.30	N.E. ANCHOR BOLT FOR MAST ARM POLE @ S.E. CORNER OF GEDDES AND OBSERVATORY.
17	910.59	SET RR SPIKE IN E. SIDE OF UTILITY POLE ON W. SIDE OF OBSERVATORY POLE IS 2ND POLE S. OF N. UNIVERSITY CT.
18	907.21	TOP, E. SIDE OF CONCRETE BASE FOR LIGHT POLE ON W. SIDE OF OBSERVATORY. LIGHT POLE IS 2ND POLE N. OF N. UNIVERSITY CT.
19	904.99	SET RR SPIKE IN W. SIDE OF UTILITY POLE ON E. SIDE OF OBSERVATORY. POLE IS 2ND POLE S. OF S. ENTRANCE INTO UoMm PARKING LOT "M34".
20	906.07	SW ANCHOR BOLT FOR LIGHT POLE @ SE CORNER OF OBSERVATORY AND WASHINGTON HEIGHTS.
21	906.89	SW ANCHOR BOLT FOR LIGHT POLE ON E. SIDE OF OBSERVATORY. LIGHT POLE IS 200FT S. OF CENTERLINE OF E. MEDICAL CENTER DR.
22	904.84	SW ANCHOR BOLT FOR LIGHT POLE IN MEDIAN AT CENTERLINE OF E. MEDICAL CENTER DR.
23	903.96	CITY OF ANN ARBOR BRASS DISC @ NE CORNER OF OBSERVATORY AND E. MEDICAL CENTER DR.
24	901.69	SE ANCHOR BOLT FOR LIGHT POLE ON W. SIDE OF OBSERVATORY @ SIDEWALK LEADING TO OBSERVATORY SITE.
25	896.02	SE ANCHOR BOLT FOR LIGHT POLE ON N. SIDE OF ANN ST. LIGHT POLE IS 150FT W. OF CENTERLINE OF OBSERVATORY.
26	902.10	SET RR SPIKE IN N. SIDE OF UTILITY POLE ON S. SIDE OF N. UNIVERSITY CT. POLE IS 3RD POLE W. OF OBSERVATORY.
27	893.85	TOP, E. SIDE OF CONCRETE BASE FOR LIGHT POLE. LIGHT POLE IS 75FT N. OF END OF CUL-DE-SAC.



	IVK	IVK	IVK	CHECKED
	JKA	JKA	JKA	DRAWN
	2/09/2016	11/05/2015	10/02/2015	DATE
	BID SET	U OF M REVIEW	PROJECT ENGINEER REVIEW	DESCRIPTION
02	01	00		REV.

CITY OF ANN ARBOR
PUBLIC SERVICE
301 EAST HURON STREET
PO BOX 8647
ANN ARBOR MI 48108-8647
www.a2gov.org



**PROJECT MANAGEMENT - CITY OF ANN ARBOR
PUBLIC SERVICES - CITY OF ANN ARBOR
OBSERVATORY STREET IMPROVEMENT
PROJECT**

SCALE PLAN: NA
DRAWING No. 2015025-3

UTILITY TRENCH DETAILS

NOTES:

1. PAVEMENT REMOVAL IS INCLUDED IN PRICE OF UTILITY
2. DENSITY TESTING PER CITY OF ANN ARBOR SPECIFICATION
3. TRENCH DETAILS SHOW TYPE OF BACKFILL AND SURFACE RESTORATION ONLY.
4. ALL TRENCHING TO CONFORM TO ALL APPLICABLE M.I.O.S.H.A. STANDARDS

BITUMINOUS PAVEMENT, WEARING COURSE, 5E-10 HIGH STRESS, 1.5"
 BITUMINOUS PAVEMENT, LEVELING COURSE, 4E-10 HIGH STRESS, 2.0"
 BITUMINOUS PAVEMENT, BASE COURSE, 3E-10 HIGH STRESS, 2.5"
 COMPACTED TO 92-96% OF THEORETICAL MAXIMUM DENSITY. TO BE PAID FOR UNDER SEPARATE PAY ITEM

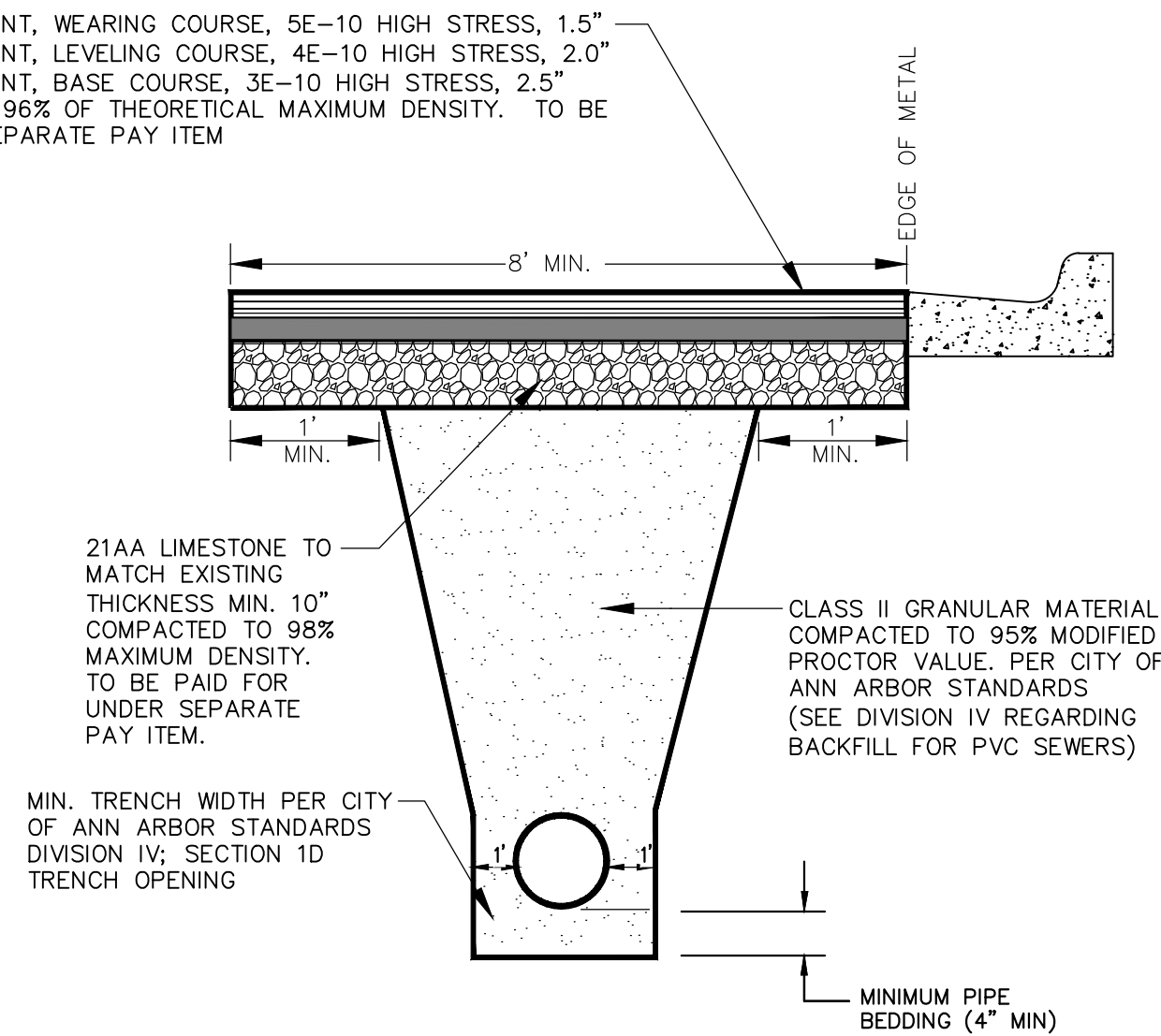

TRENCH DETAIL I, MODIFIED
NO SCALE

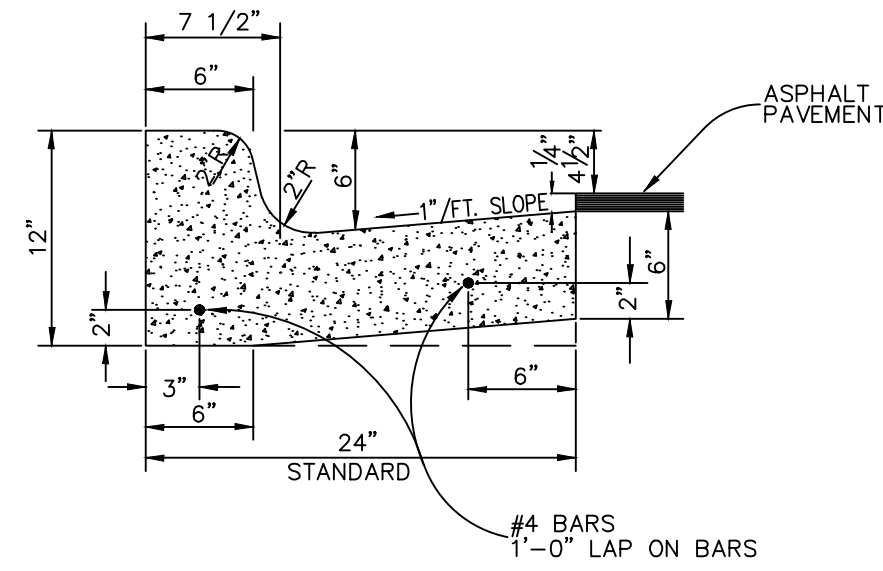

CURB, CONC, DET F4
NO SCALE

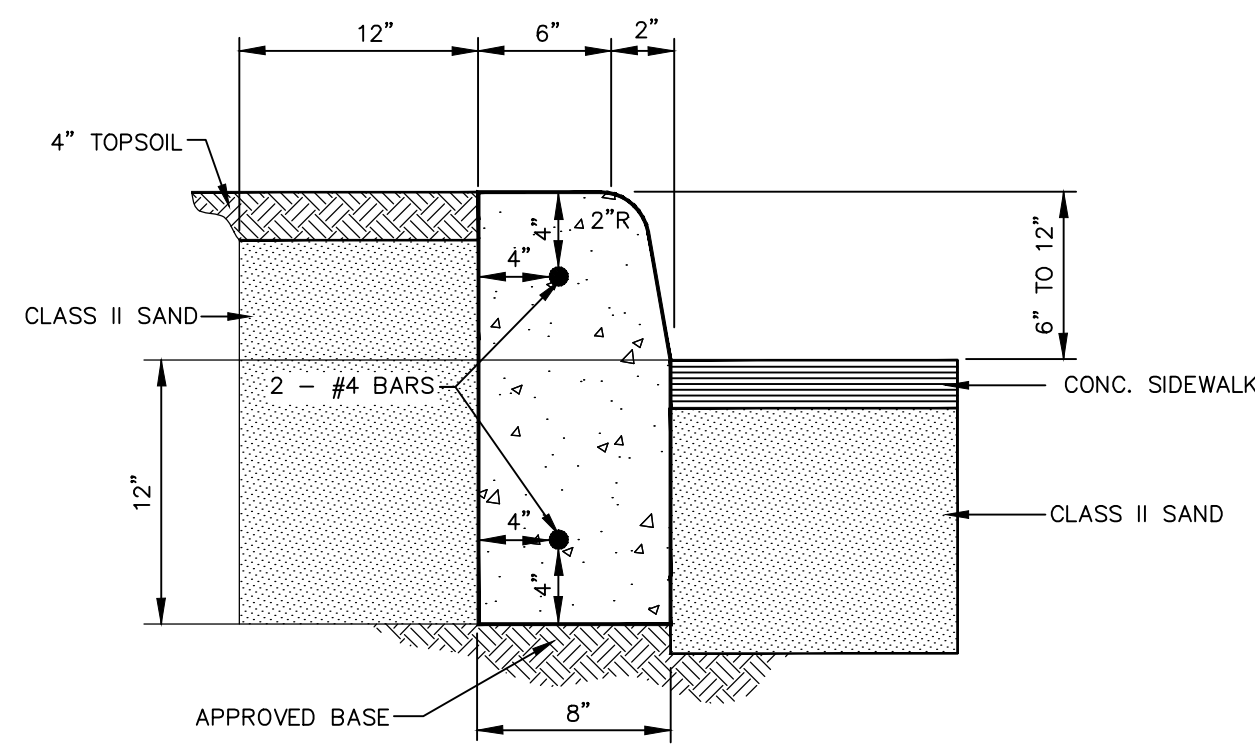

CURB, CONC, DET E2, MODIFIED
NO SCALE

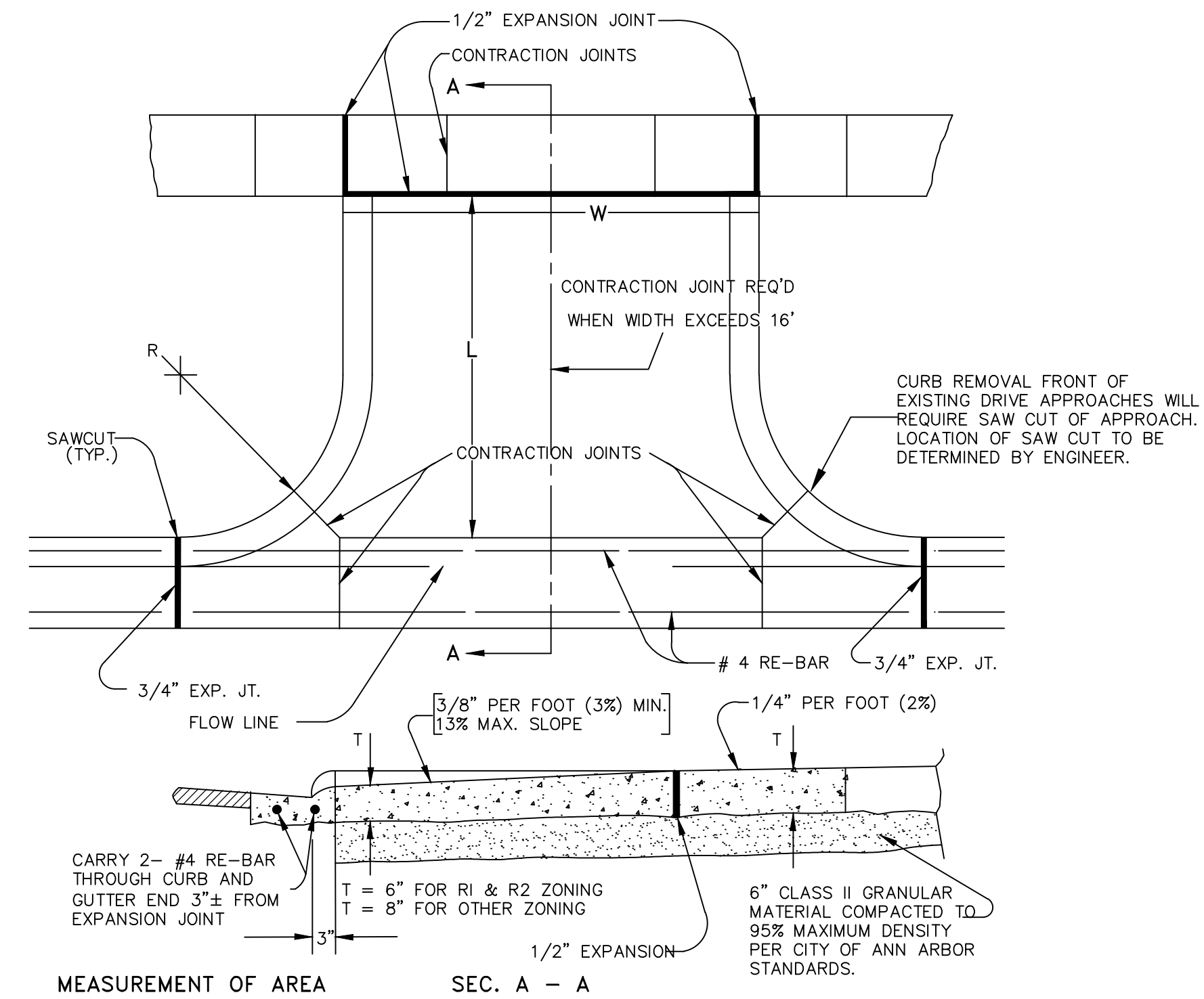

MEASUREMENT OF AREA
 $W \times L = \text{AREA}$
 NOTE: DRIVE APPROACH TO BE CLASS 'A' CONCRETE
 NOTE: R (RADIUS) AND W (DRIVE WIDTH) AS REQUIRED FOR ZONING BY CITY CODE
 NOTE: IF GUTTER IS OVERLAYED, GUTTER OF THE APPROACH SHALL BE AT SAME ELEVATION AS EXISTING GUTTER AND ASPHALT WEDGE SHALL BE PLACED IN THE APPROACH.

TYPE "M" DRIVE APPROACH

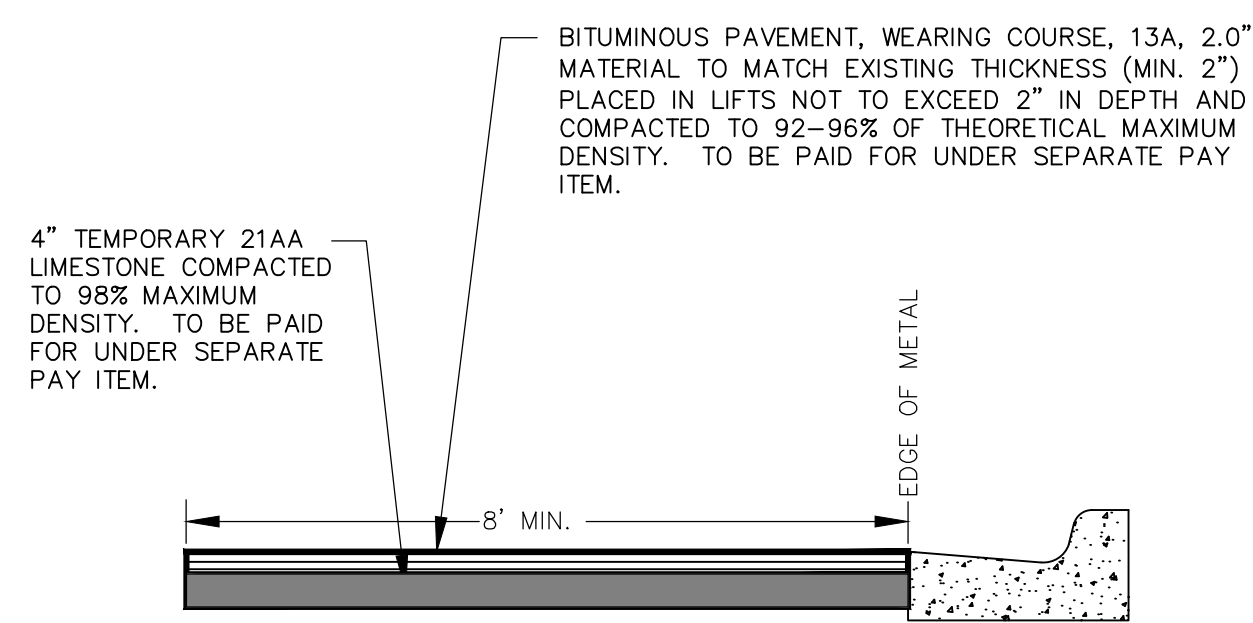

TEMPORARY PATCH

TEMPORARY PATCH

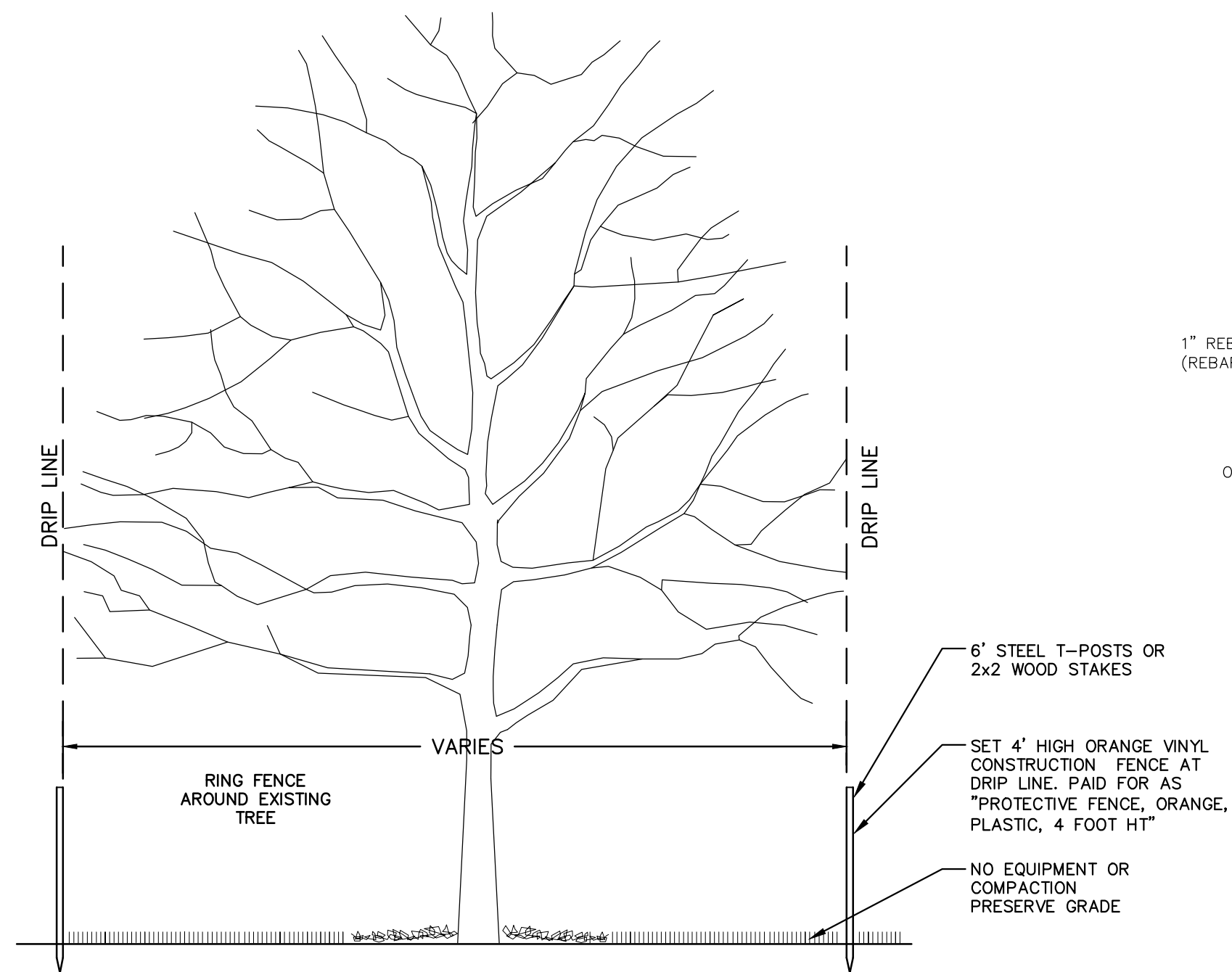

TREE PROTECTION DETAIL

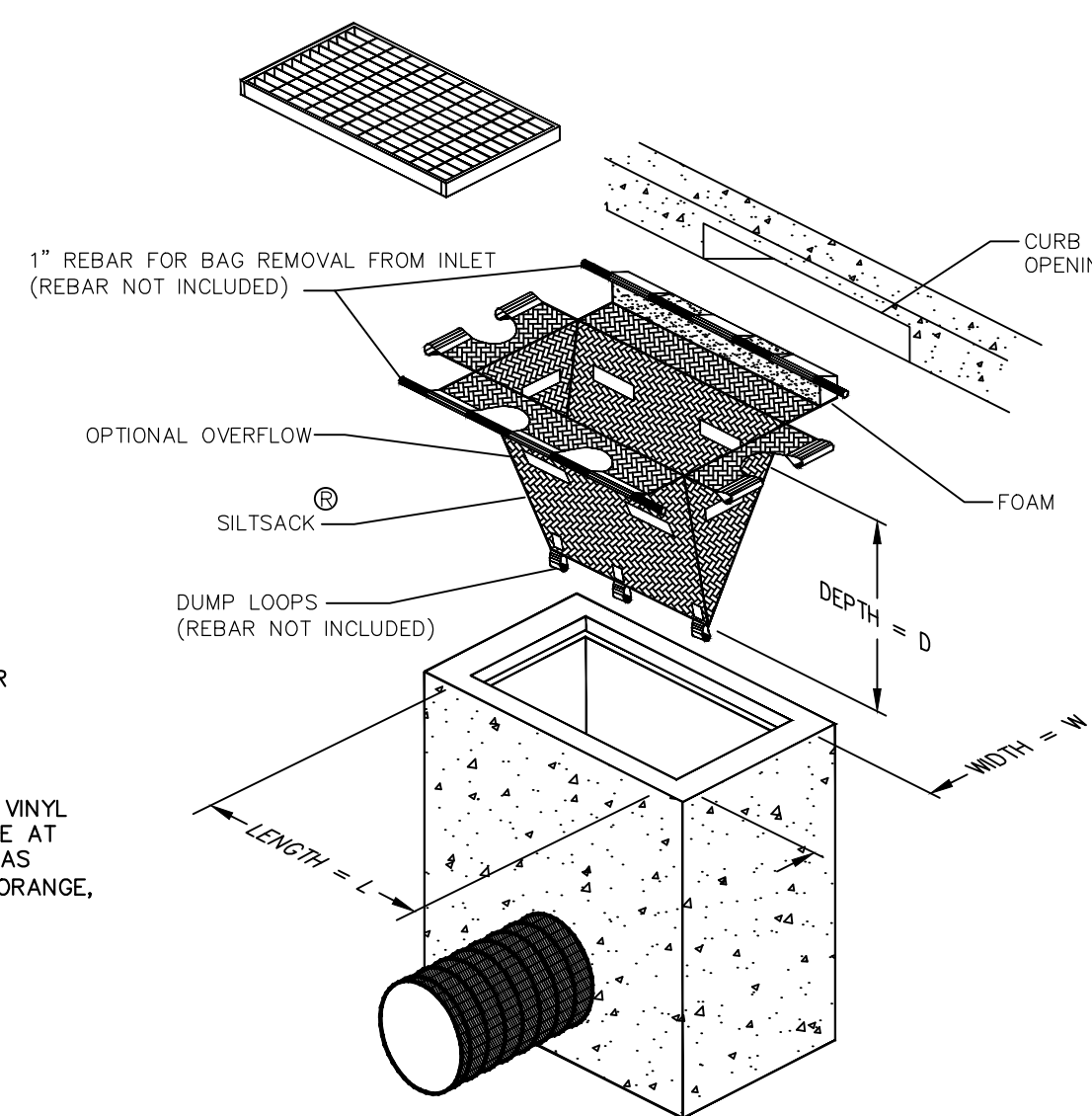

INLET FILTER (MODIFIED)

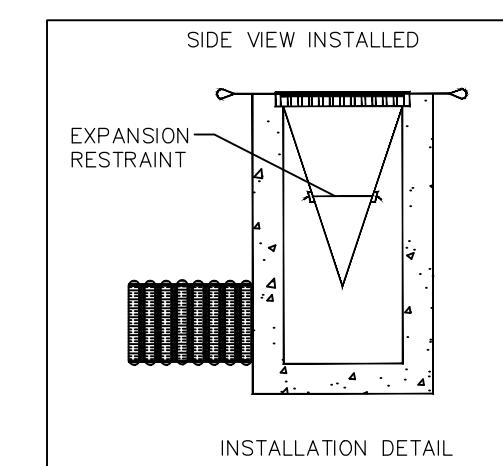

INSTALLATION DETAIL

SILTSACK® SPECIFICATIONS

NOTE: THE SILTSACK WILL BE MANUFACTURED FROM A WOVEN POLYPROPYLENE FABRIC THAT MEETS OR EXCEEDS THE FOLLOWING SPECIFICATIONS.

REGULAR FLOW SILTSACK®
(FOR AREAS OF LOW TO MODERATE PRECIPITATION AND RUN-OFF)

PROPERTIES	REQUIRED VALUE	TEST METHOD
GRAB TENSILE STRENGTH	ASTM D-4632	300 LBS
GRAB TENSILE ELONGATION	ASTM D-4632	20%
PUNCTURE	ASTM D-4833	120 LBS
MULLEN BURST	ASTM D-3786	800 PSI
TRAPEZOID TEAR	ASTM D-4533	120 LBS
UV RESISTANCE	ASTM D-4355	80%
APPARENT OPENING SIZE	ASTM D-4751	40 US SIEVE
FLOW RATE	ASTM D-4491	40 GAL/MIN/SQ FT
PERMITTIVITY	ASTM D-4491	0.55 SEC-1

HI-FLOW SILTSACK®
(FOR AREAS OF MODERATE TO HEAVY PRECIPITATION AND RUN-OFF)

PROPERTIES	REQUIRED VALUE	TEST METHOD
GRAB TENSILE STRENGTH	ASTM D-4632	265 LBS
GRAB TENSILE ELONGATION	ASTM D-4632	20%
PUNCTURE	ASTM D-4833	135 LBS
MULLEN BURST	ASTM D-3786	420 PSI
TRAPEZOID TEAR	ASTM D-4533	45 LBS
UV RESISTANCE	ASTM D-4355	90%
APPARENT OPENING SIZE	ASTM D-4751	20 US SIEVE
FLOW RATE	ASTM D-4491	200 GAL/MIN/SQ FT
PERMITTIVITY	ASTM D-4491	1.5 SEC-1

OIL-ABSORBANT SILTSACK®
(FOR AREAS WHERE THERE IS A CONCERN FOR OIL RUN-OFF OR SPILLS)

DEPENDING ON YOUR PARTICULAR APPLICATION, THE SILTSACK® CAN BE MADE FROM EITHER ONE OF THE ABOVE FABRICS WITH AN OIL-ABSORBANT FILLW INSERT OR, MADE COMPLETELY FROM AN OIL-ABSORBANT SILTSACK® WITH A WOVEN FILLW INSERT.

S:\Project Management\Design\2015025 Observatory\Plan Production\2015025DET.dwg Dwg Created: 11-Dec-15 - _a2_standard.bw.stb - Plot Date: 12-Feb-16



REV.	DATE	DESCRIPTION	DRAWN	CHECKED
02	2/09/2016	BID SET	JKA	IVK
01	11/05/2015	U OF M REVIEW	JKA	IVK
00	10/02/2015	PROJECT ENGINEER REVIEW	JKA	IVK



PROJECT MANAGEMENT - PUBLIC SERVICES - CITY OF ANN ARBOR
OBSERVATORY STREET IMPROVEMENT PROJECT
 ROAD DET
 SCALE PLAN: NTS
 DRAWING No. 2015025 - 4

S:\Project Management\Design\2015025 Observatory\Plan Production\2015025DET.dwg Dwg Created: 11-Dec-15 - _a2 standard bw.stb - Plot Date: 12-Feb-16



IVK	IVK	IVK	IVK	CHECKED
JKA	JKA	JKA	JKA	DRAWN
2/09/2016	11/05/2015	10/02/2015	DATE	
02	01	00	REV.	
BID SET	U OF M REVIEW	PROJECT ENGINEER REVIEW	DESCRIPTION	



PROJECT MANAGEMENT - PUBLIC SERVICES - CITY OF ANN ARBOR
OBSERVATORY STREET IMPROVEMENT PROJECT
 SCALE PLAN: NTS
 DRAWING No. 2015025 - 5
 WATER DET

WATER OR GAS VALVE BOX ADJUSTMENT

NOTE: GAS VALVE BOXES TO BE ADJUSTED BY THE GAS COMPANY.

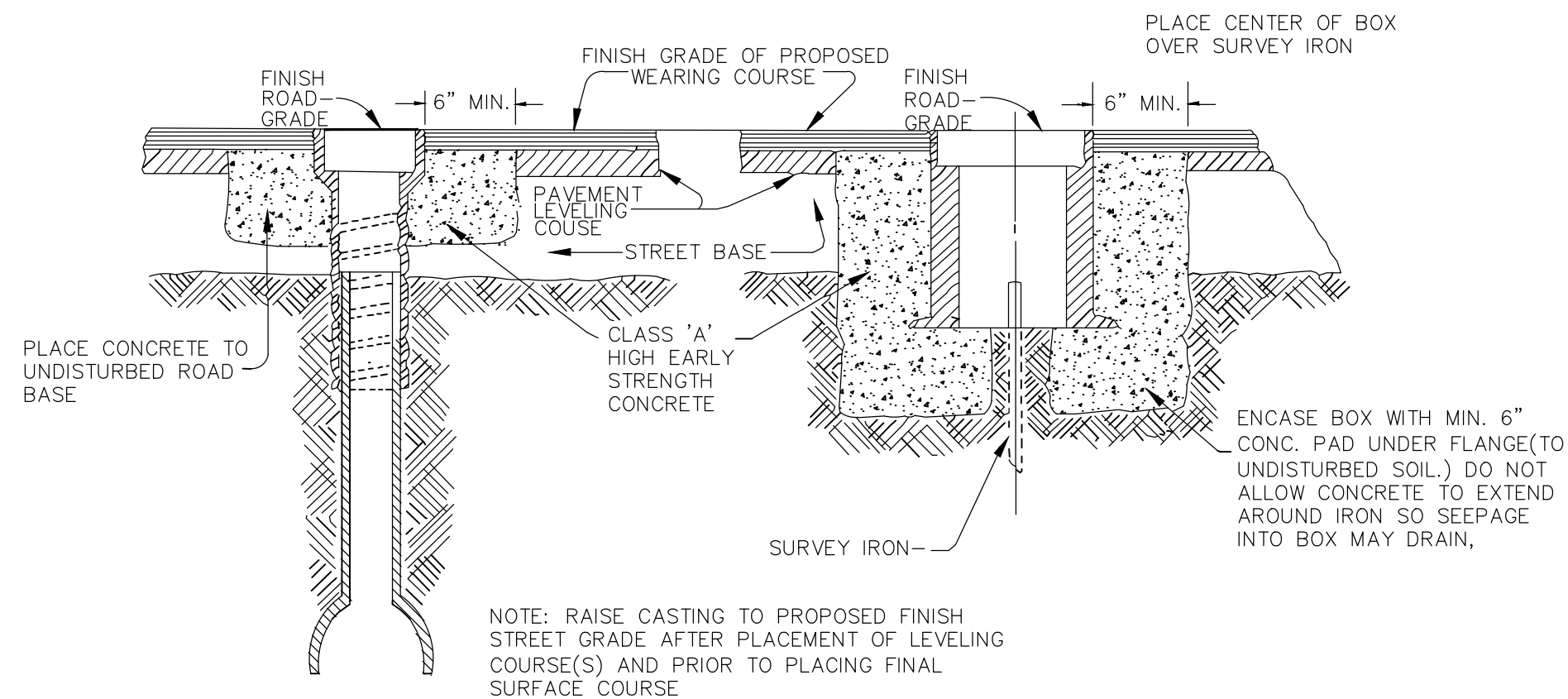

MONUMENT BOX ADJUSTMENT

VALVE/MONUMENT BOX ADJUSTMENT

PLAN-VIEW

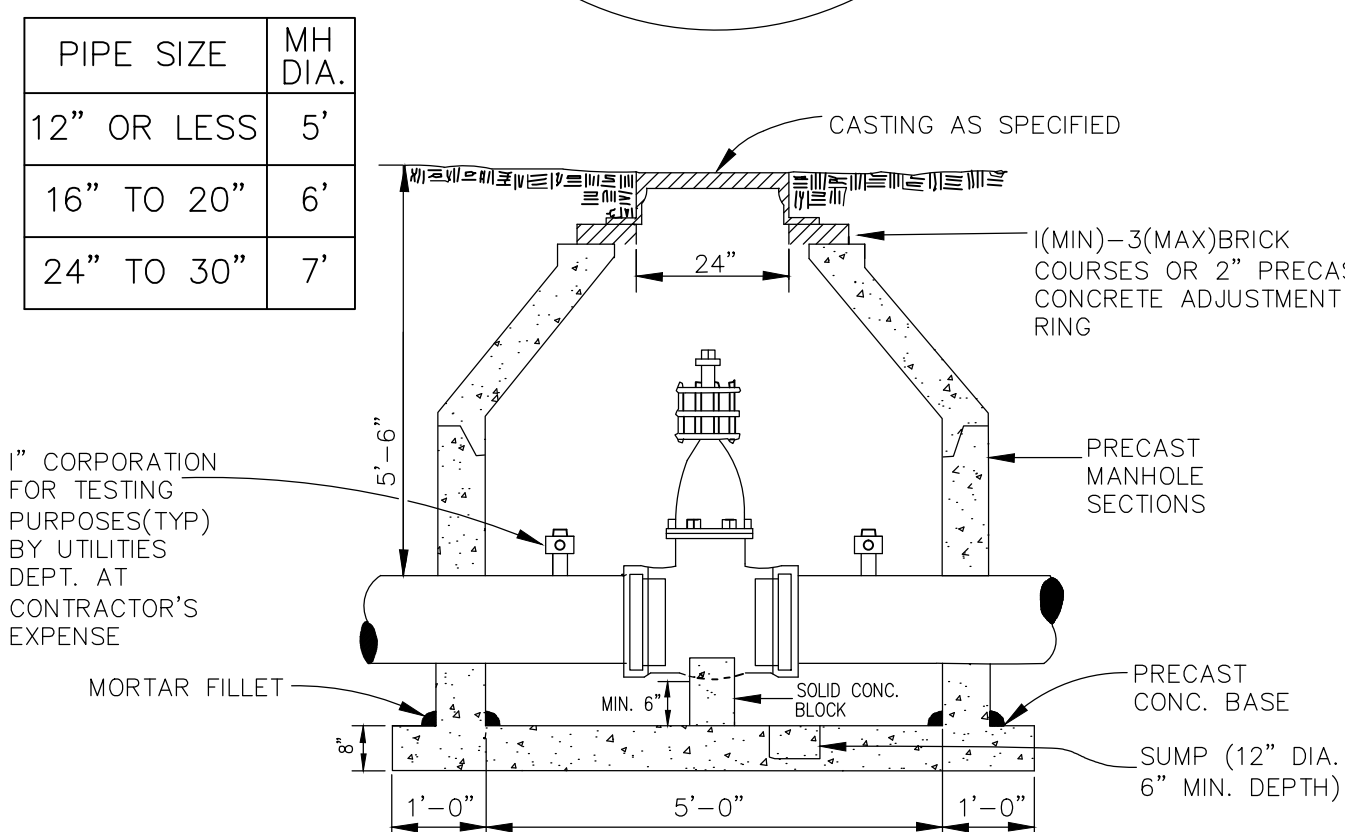
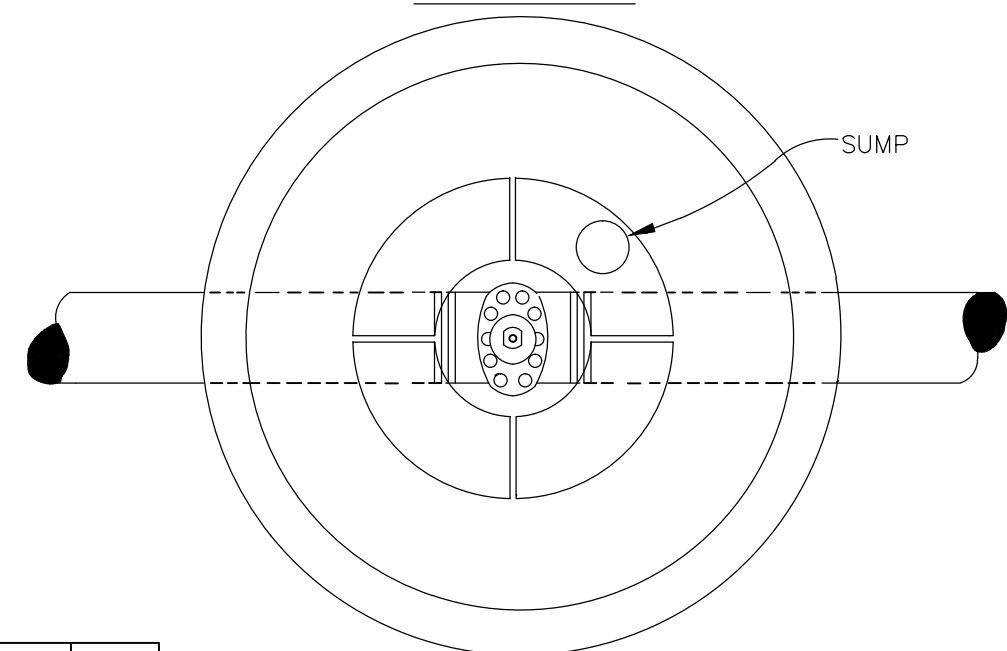

NOTE: ALL LIFT HOLES AND JOINTS SHALL BE MORTARED BOTH INSIDE AND OUTSIDE.

NOTE: ALL JOINTS MADE WATER TIGHT WITH RUBBER GASKET JOINTS

NOTE: NO STEPS PERMITTED

GATE WELL FOR MAIN 16" AND SMALLER

REMOVE CAP AND INSERT POLY-PIG SWAB
 REPLACE CAP AND ATTACH PRESSURE HOSE TO 2" CORP.

USING PRESSURE PUMP, INSERT POLY-PIG SWAB INTO WATER MAIN TO BE SWABBED. WHEN SWAB IS IN MAIN, STOP PUMP, CRACK G.V. AND FLUSH MAIN.
 UPON COMPLETION OF FLUSHING, TEE TO BE REMOVED OR CAPPED AT BRANCH FLANGE.

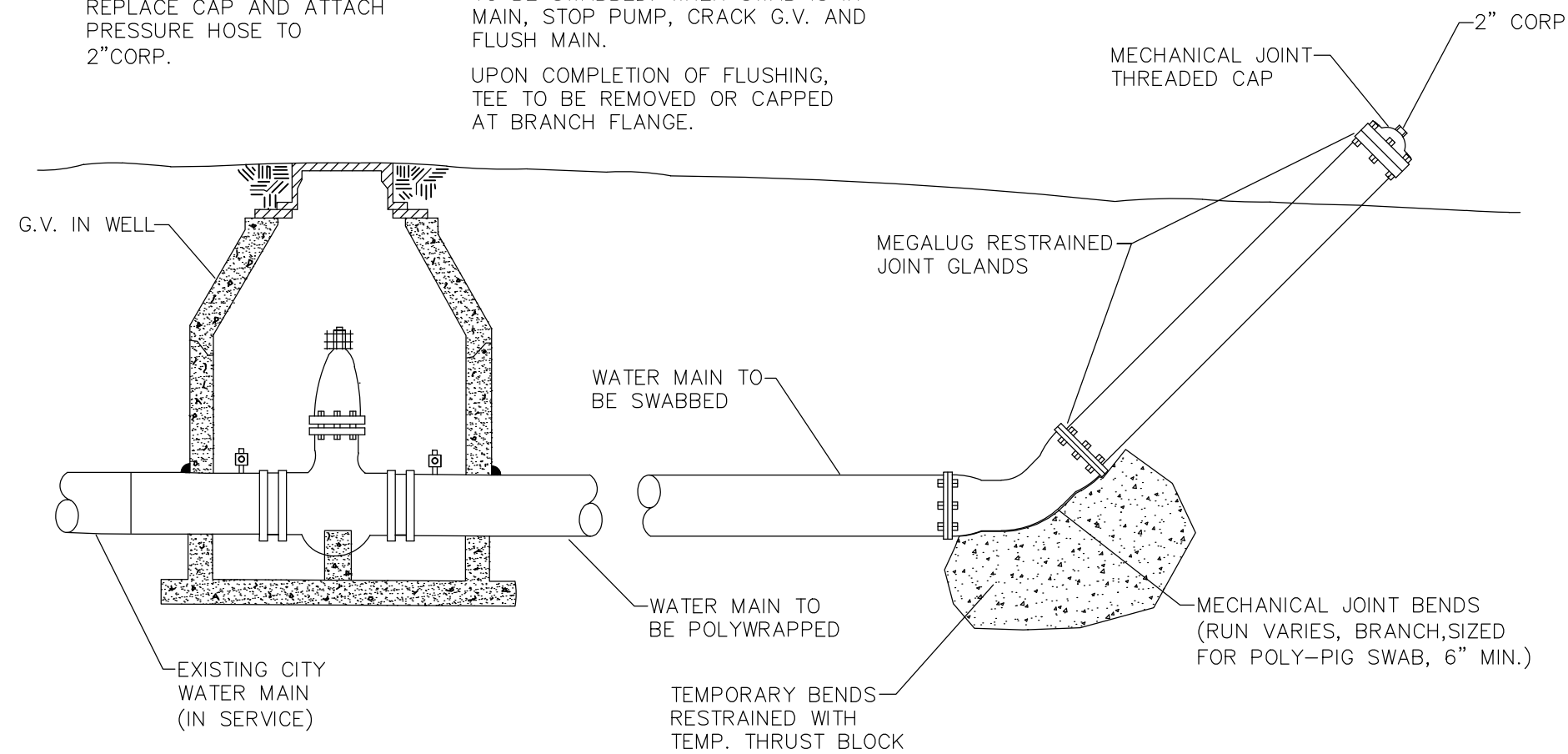

SWAB LAUNCHING, MODIFIED

MINIMUM STANDARDS

REACTION BACKING: The Class "A" concrete at the Fitting face shall extend to within (2) inches of the bell and shall extend from the fitting face a minimum of (2) feet to the UNDISTURBED SOLID GROUND. The dimensions of the reaction backing (thrust block) at the face of the undisturbed solid ground shall be as shown in the Table below. If there isn't sufficient space for the installation of the "thrust block" without interference with other services, another arrangement satisfactory to the engineer shall be used, i.e. encasement.

Fittings I.D. Inches	Plug Tee Cross		Bends				Hydrant	
	W	H	90° W	90° H	45° W	45° H	22 1/2° W	22 1/2° H
2.5	1	1	1	1	1	1		
4	1	1	1	1	1	1		
6	2	1.5	2	2	2	1	1	1
8	2.5	2	3.5	2	2	2	1	1
12	3.5	3	5.5	3	3.5	2.5	2	2
16	6	3.5	6	4	5	3	3.5	2.5
20	8	4	12	4	6	4	4	3
24	11	4	17	4	9	4	6	4
30	11	4	17	4	9	4	6	4

W = WIDTH IN FEET
 H = HEIGHT IN FEET

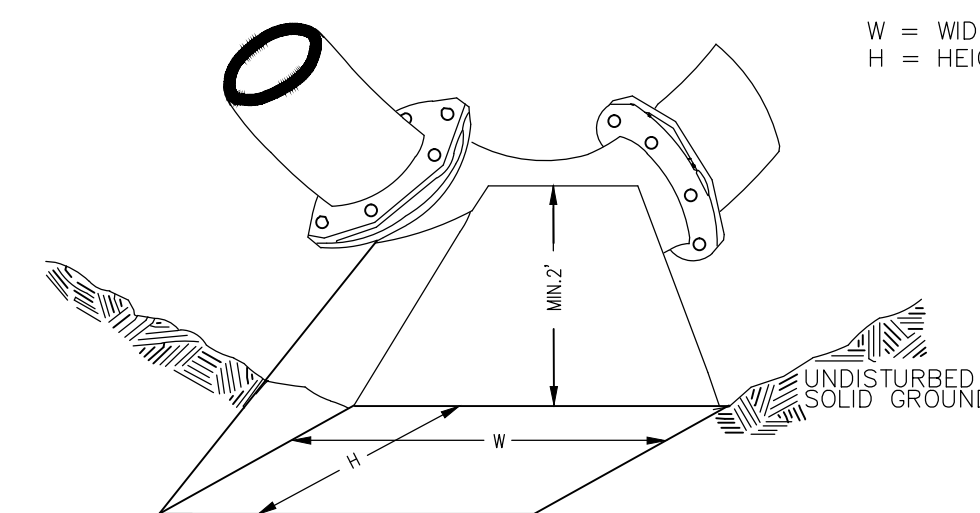

NOTE: THESE ARE MINIMUM STANDARDS. WHERE SOIL CONDITIONS DICTATE, ADJUSTMENTS IN SIZE SHALL BE MADE BY THE PUBLIC SERVICES DIRECTOR.

THRUST BLOCK

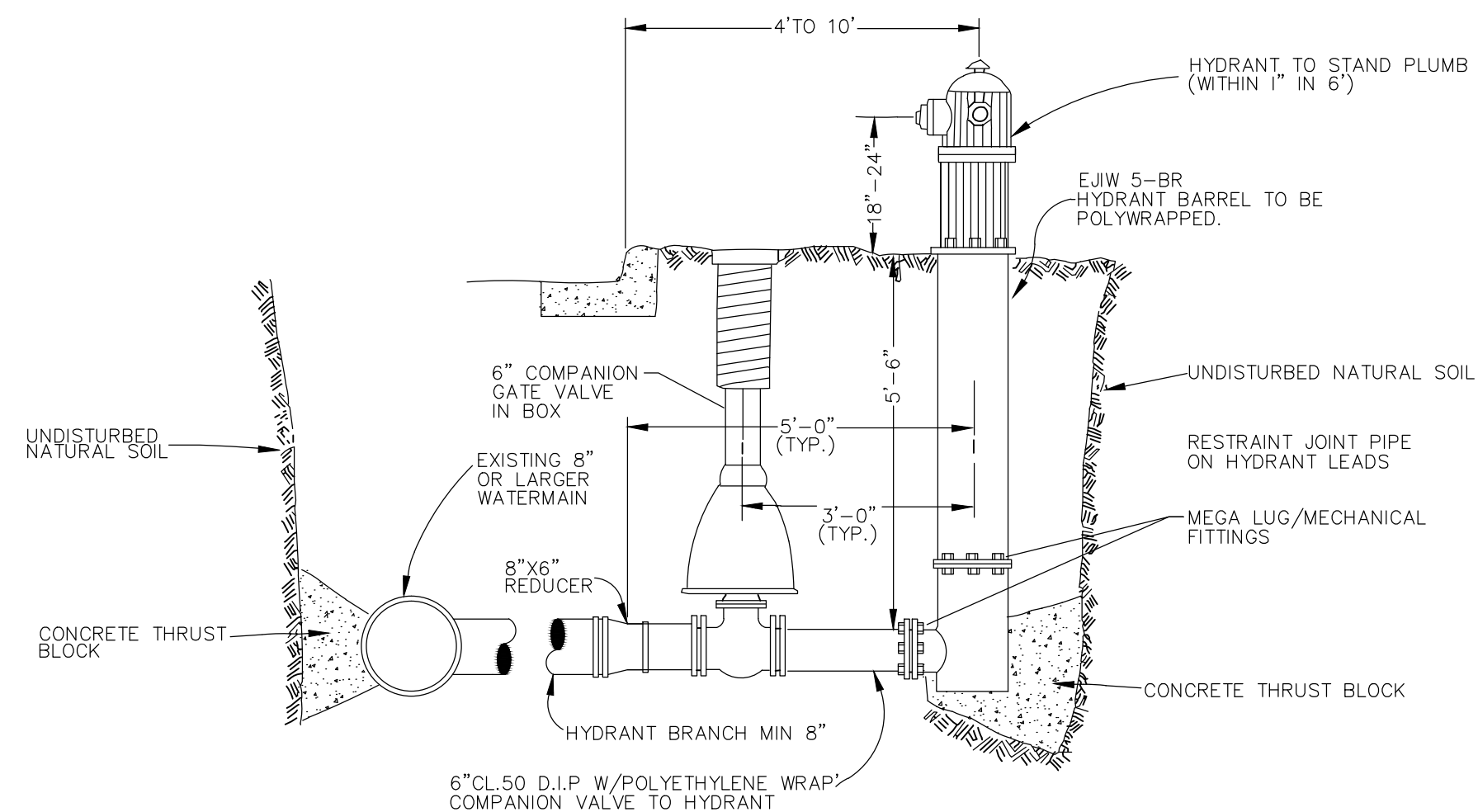

NOTE: ALL PIPE, FITTINGS AND HYDRANT BARREL TO BE POLYWRAPPED PER AWWA C105

FIRE HYDRANT ASSEMBLY, MODIFIED

S:\Project Management\Design\2015025 Observatory\Plan Production\2015025DET.dwg Dwg Created: 11-Dec-15 - _a2 standard bw.stb - Plot Date: 12-Feb-16

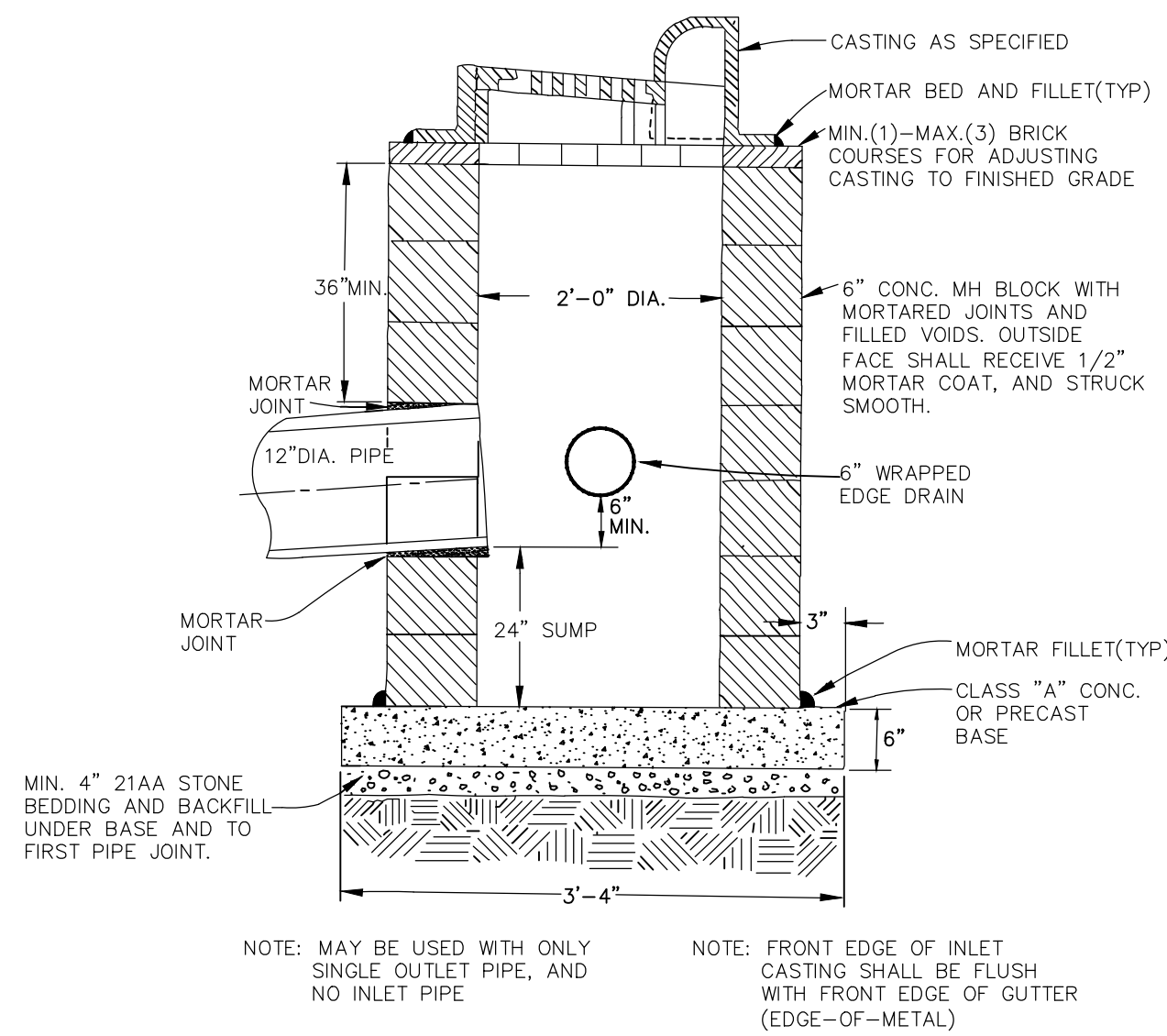

SINGLE INLET STRUCTURE

TYPE OF CASTING	NEEHAH FOUNDRY	EAST JORDAN IRON WORKS
Barrier Curb Inlet for 24 and 30 inch curb	R-3013B, Type S grate (500 Pounds)	7045, Type M1 grate (490 Pounds)
Barrier Curb Inlet for 18 inch curb		7210, Type M2 grate (490 Pounds)
*Manhole Frame & Cover	R-1642, Type C Cover (380 Pounds)	1040, Type A Cover (400 Pounds)
**Watertight Manhole Frame and Cover	N/A	1040-WT (400 Pounds)
Monument Box	N/A	8360 (100 Pounds)

*Frames and covers must have machined bearing surfaces. Covers must have two (2) 1" vent holes located opposite each other and 6" from the edge of the cover. Each cover shall have "Sewer", "S" or "Water", "W" cast in the surface, whichever is applicable.

**Frames and covers must have machined bearing surfaces. Each cover shall have "Sewer", "S" or "Water", "W" cast in the surface, whichever is applicable.

STANDARD CASTING SCHEDULE

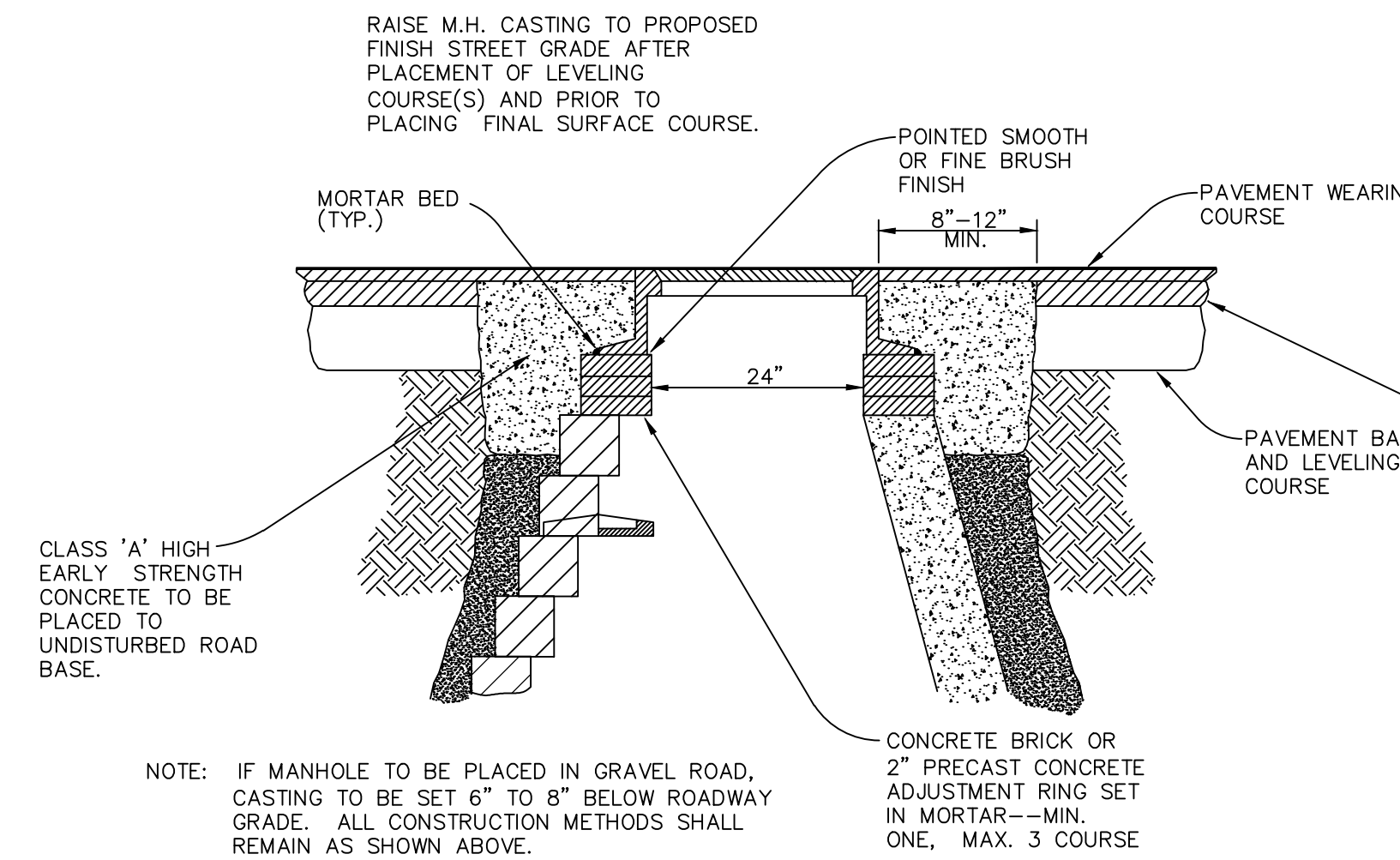

MANHOLE CASTING ADJUSTMENT

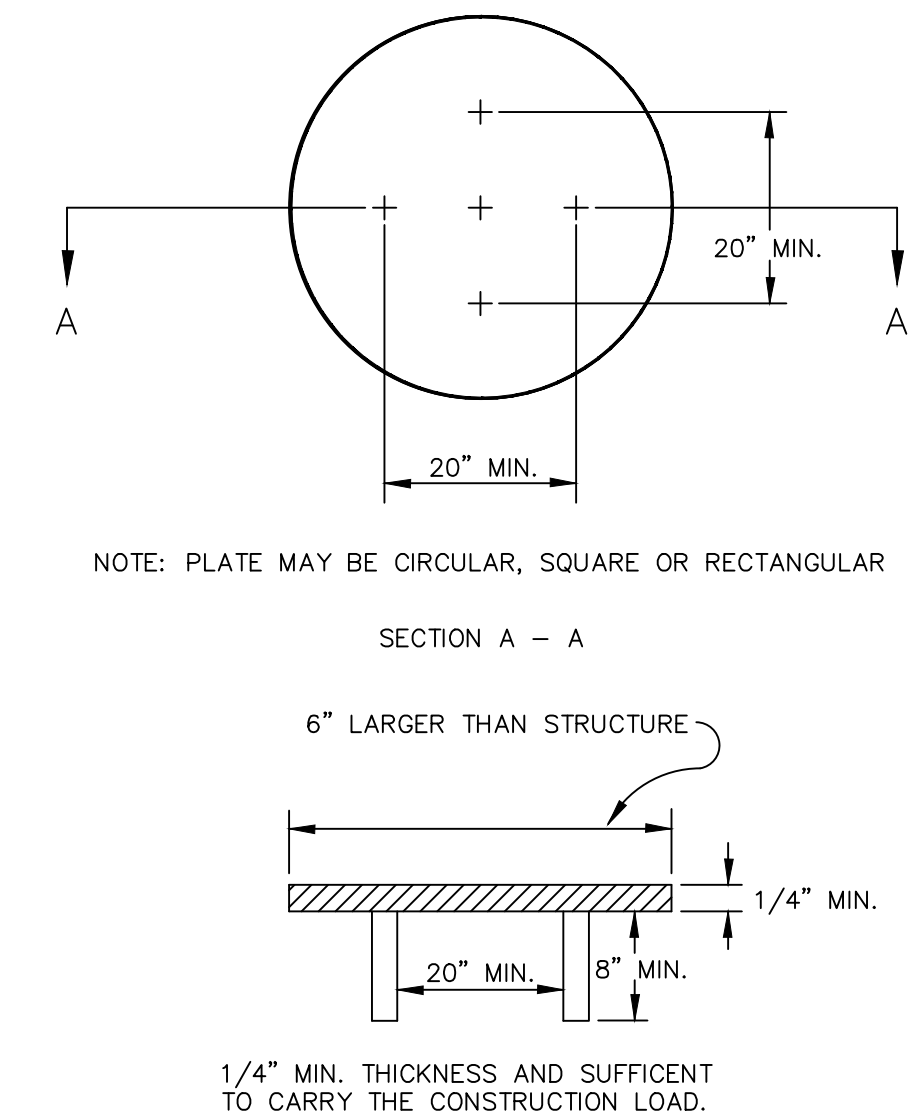

STRUCTURE PLATE

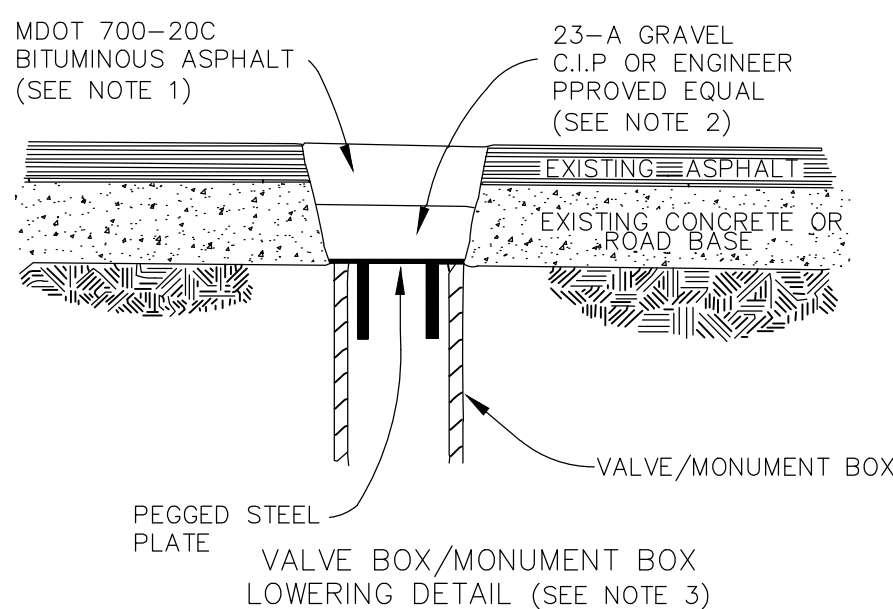
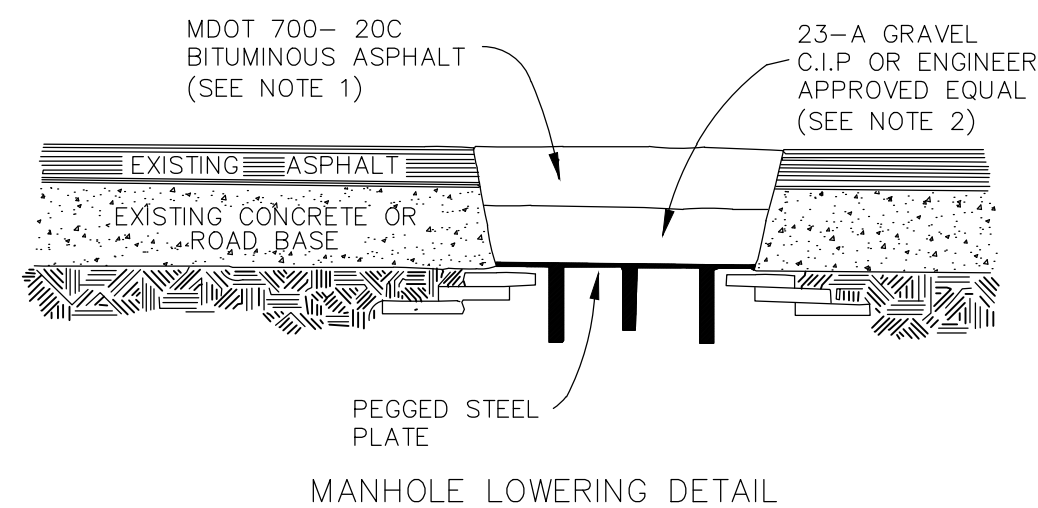

NOTE 1: IF TRAFFIC IS TO BE MAINTAINED ON THE ROADWAY BEFORE OR AFTER THE COLD MILLING OPERATION, THE STRUCTURE SHALL BE LOWERED TO THE EXTENT THAT A MINIMUM OF THREE(3) INCHES ASPHALT MATERIAL MDOT 700-20C, OR ENGINEER APPROVED EQUAL, REMAINS TO SUPPORT TRAFFIC.

NOTE 2: IF THE ROADWAY BEING MILLED IS CLOSED TO TRAFFIC, THE STRUCTURE SHALL BE LOWERED SUCH THAT THE STEEL PLATE IS A MINIMUM OF FOUR(4) INCHES BELOW THE PROPOSED ROAD GRADE AND THE RESULTING VOID SHALL BE FILLED WITH COMPACTED 23-A GRAVEL OR ENGINEER APPROVED EQUAL.

NOTE 3: WHERE A MONUMENT IS TO BE LOWERED, THE CONTRACTOR SHALL GIVE THE ENGINEER A MINIMUM OF 48 HOURS WRITTEN NOTICE SO THAT THE MONUMENT CAN BE PROPERLY WITNESSED OR PROTECTED. FAILURE TO DO SO SHALL RESULT IN THE REPLACING SAID MONUMENT AT THE CONTRACTORS EXPENSE.

MANHOLE & VALVE/MONUMENT BOX LOWERING

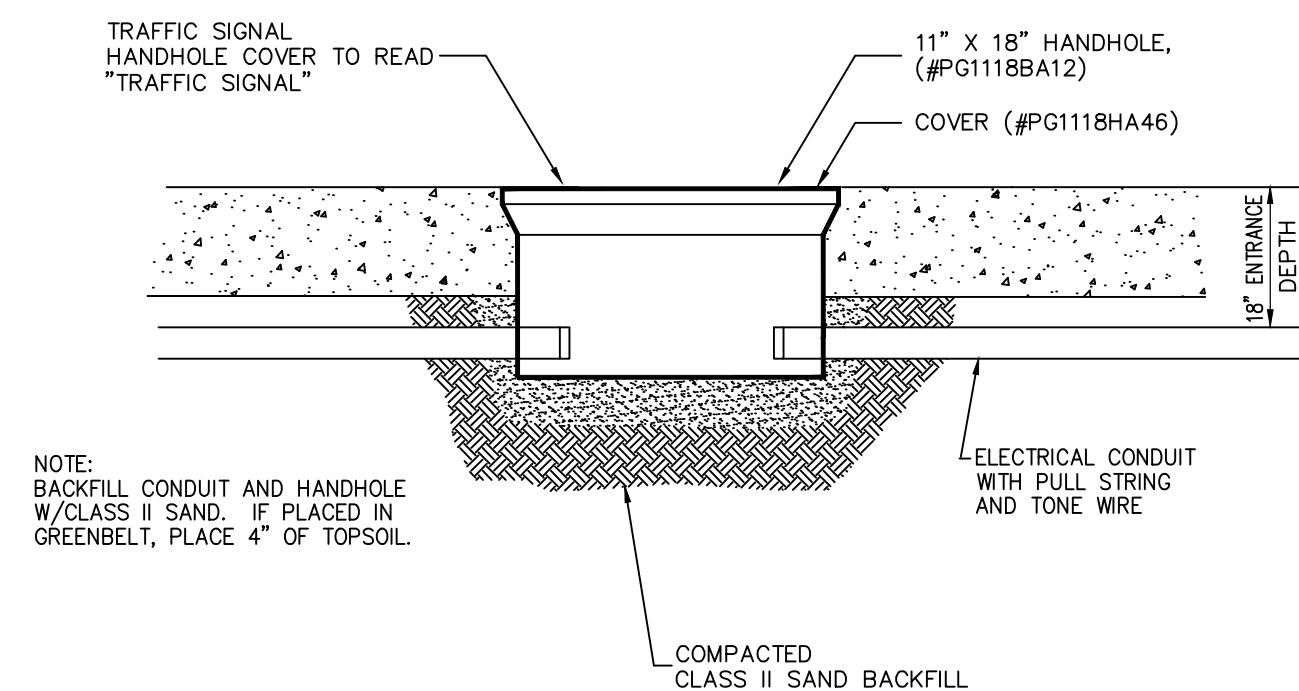

TRAFFIC SIGNAL HANDHOLE DETAIL

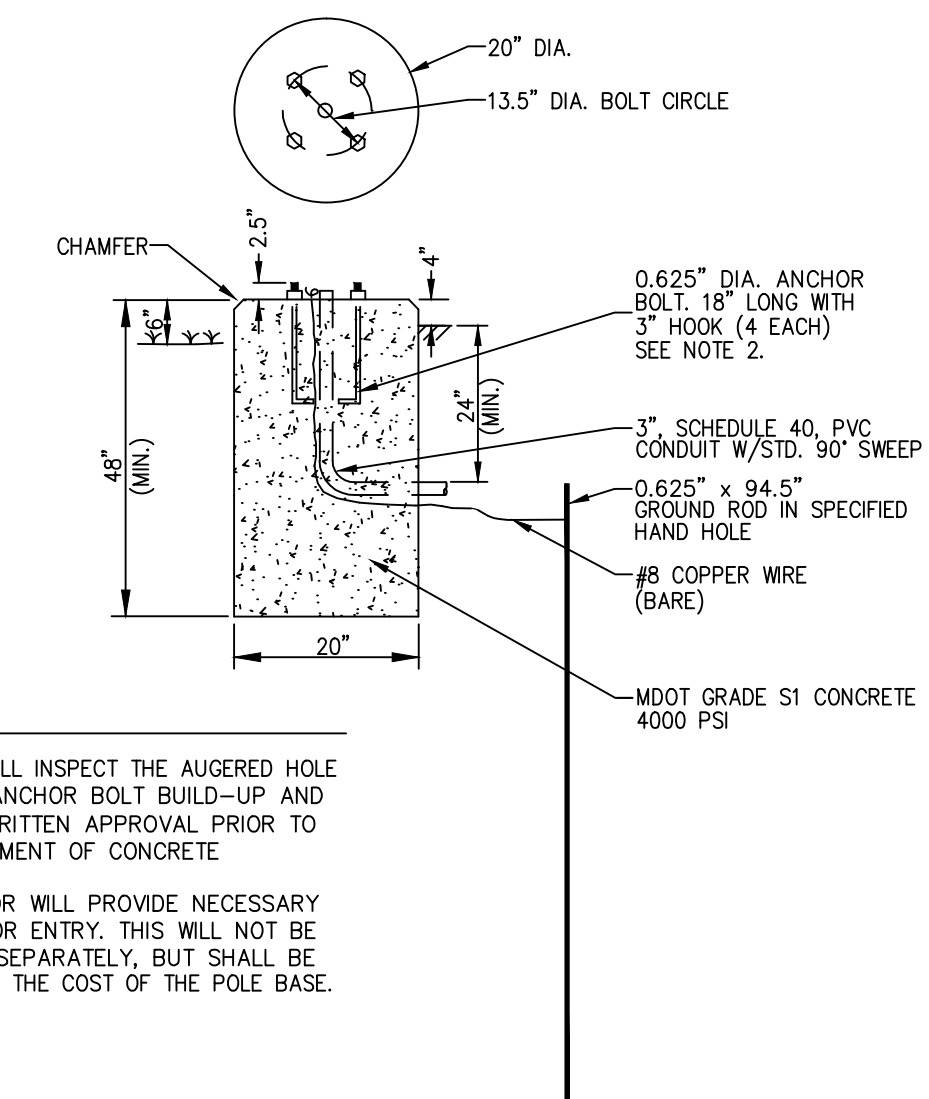

NOTES:

1. THE CITY WILL INSPECT THE AUGERED HOLE AND THE ANCHOR BOLT BUILD-UP AND PROVIDE WRITTEN APPROVAL PRIOR TO THE PLACEMENT OF CONCRETE
2. CONTRACTOR WILL PROVIDE NECESSARY CONDUIT FOR ENTRY. THIS WILL NOT BE PAID FOR SEPARATELY, BUT SHALL BE INCLUDED IN THE COST OF THE POLE BASE.

PEDESTRIAN SIGNAL POLE FOUNDATION DETAIL



REV	DATE	DESCRIPTION
02	2/09/2016	BID SET
01	11/05/2015	U OF M REVIEW
00	10/02/2015	PROJECT ENGINEER REVIEW



PROJECT MANAGEMENT - PUBLIC SERVICES - CITY OF ANN ARBOR
OBSERVATORY STREET IMPROVEMENT PROJECT
 SCALE PLAN: NTS
 DRAWING No. 2015025 - 6
 SHEET No. 6 OF 40

STRC DET

S:\Project Management\Design\2015025 Observatory\Plan Production\2015025DET.dwg Dwg Created: 11-Dec-15 -- a2 standard bw.stb -- Plot Date: 12-Feb-16

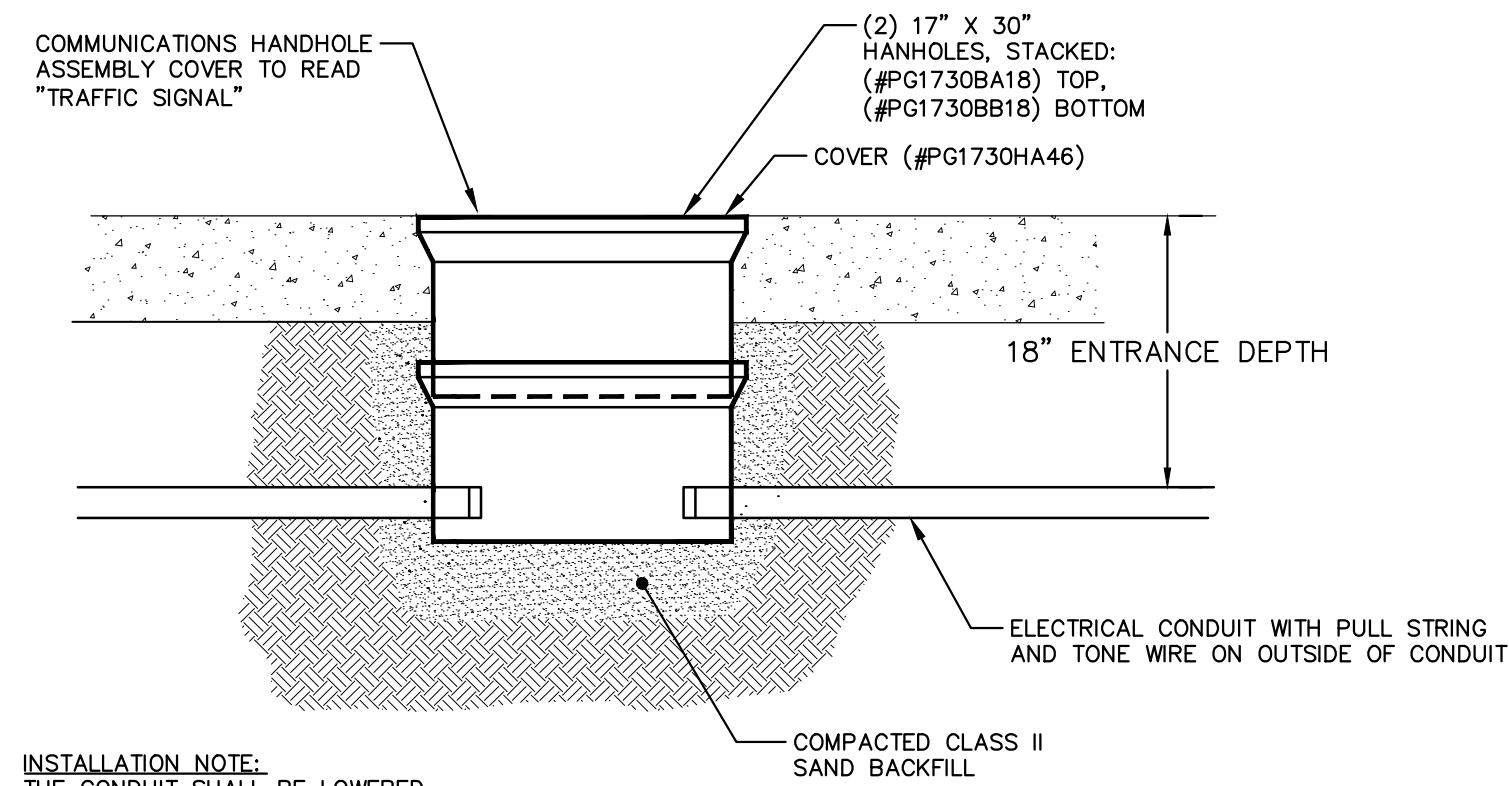

INSTALLATION NOTE:
THE CONDUIT SHALL BE LOWERED TO A MINIMUM ENTRANCE DEPTH OF 36" BELOW TOP OF THE HAND HOLE OVER A DISTANCE OF 10' ON EACH SIDE OF THE HANDHOLE ASSEMBLY.

COMMUNICATIONS HANDHOLE ASSEMBLY

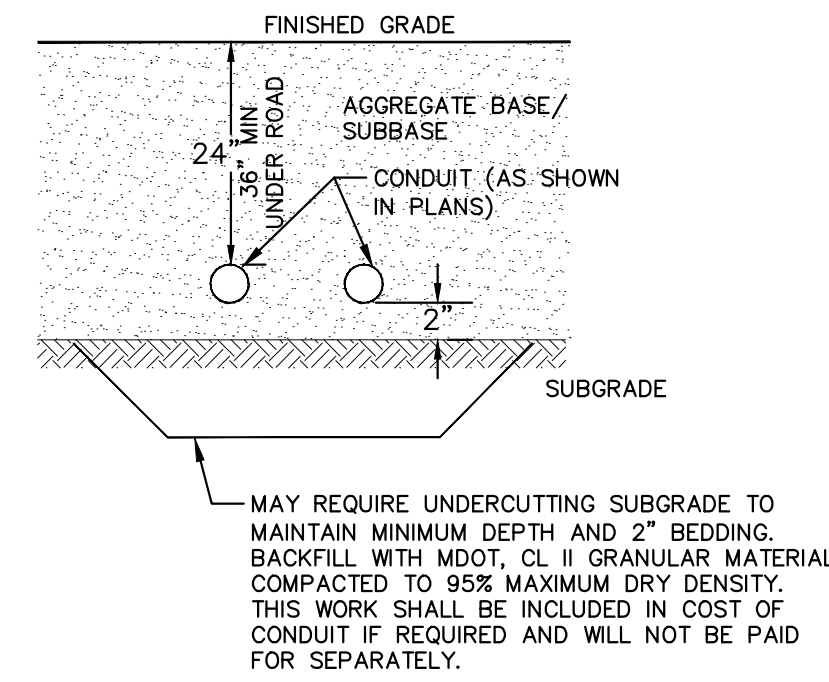

CONDUIT PLACEMENT DETAIL

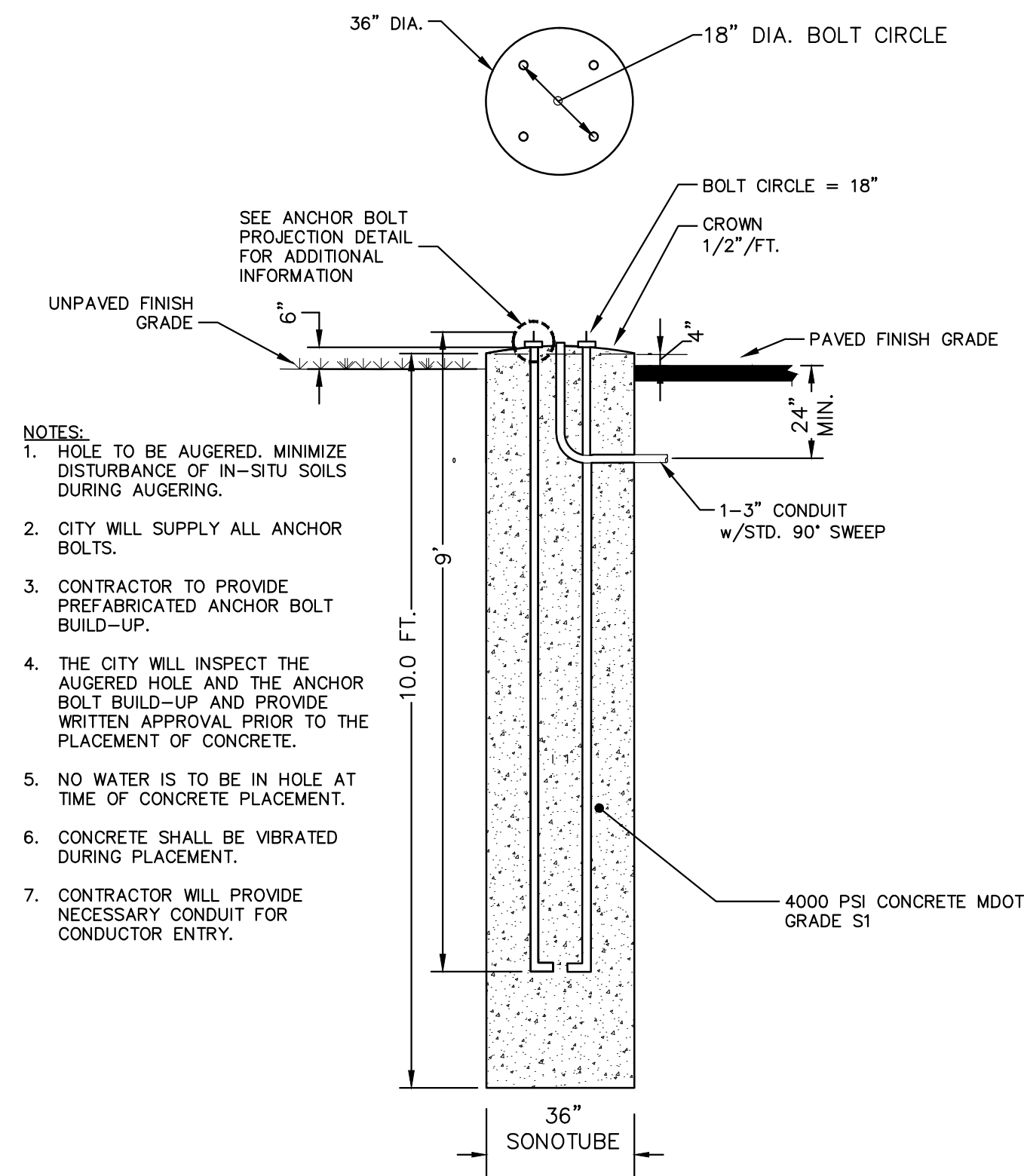

- NOTES:
- HOLE TO BE AUGERED. MINIMIZE DISTURBANCE OF IN-SITU SOILS DURING AUGERING.
 - CITY WILL SUPPLY ALL ANCHOR BOLTS.
 - CONTRACTOR TO PROVIDE PREFABRICATED ANCHOR BOLT BUILD-UP.
 - THE CITY WILL INSPECT THE AUGERED HOLE AND THE ANCHOR BOLT BUILD-UP AND PROVIDE WRITTEN APPROVAL PRIOR TO THE PLACEMENT OF CONCRETE.
 - NO WATER IS TO BE IN HOLE AT TIME OF CONCRETE PLACEMENT.
 - CONCRETE SHALL BE VIBRATED DURING PLACEMENT.
 - CONTRACTOR WILL PROVIDE NECESSARY CONDUIT FOR CONDUCTOR ENTRY.

MAST ARM FOUNDATION SD-SL-2

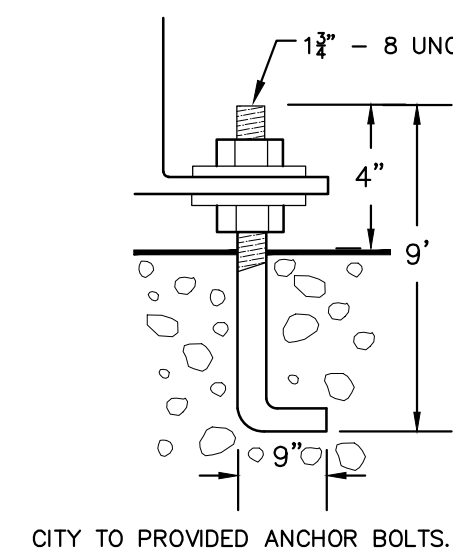

ANCHOR BOLT PROJECTION DETAIL

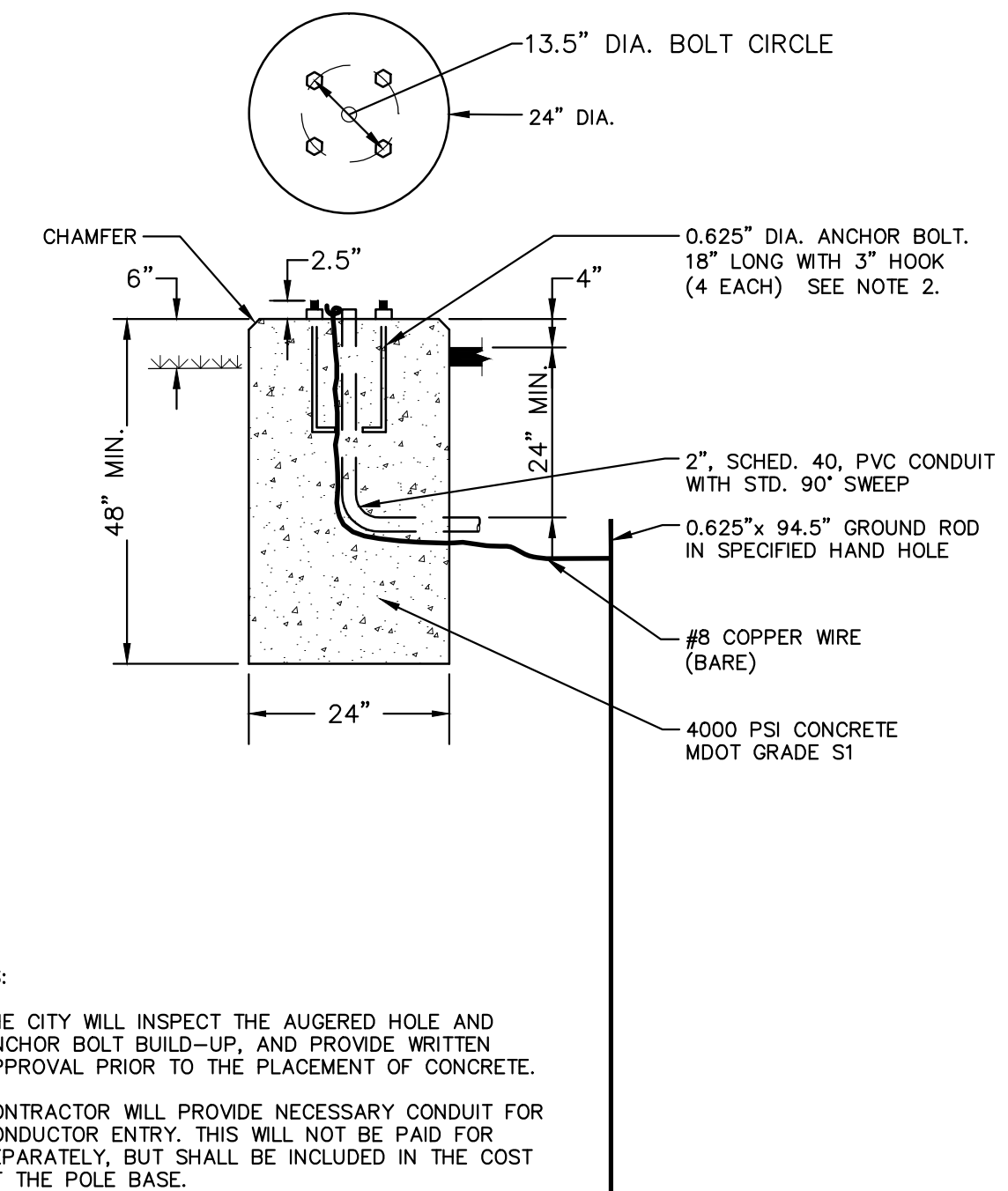

NOTES:

- THE CITY WILL INSPECT THE AUGERED HOLE AND ANCHOR BOLT BUILD-UP, AND PROVIDE WRITTEN APPROVAL PRIOR TO THE PLACEMENT OF CONCRETE.
- CONTRACTOR WILL PROVIDE NECESSARY CONDUIT FOR CONDUCTOR ENTRY. THIS WILL NOT BE PAID FOR SEPARATELY, BUT SHALL BE INCLUDED IN THE COST OF THE POLE BASE.

PEDESTRIAN SIGNAL POLE FOUNDATION SD-SL-3



IVK	IVK	IVK	IVK	CHECKED
JKA	JKA	JKA	JKA	DRAWN
2/09/2016	11/05/2015	10/02/2015	DATE	
BID SET	U OF M REVIEW	PROJECT ENGINEER REVIEW	DESCRIPTION	
02	01	00	REV.	

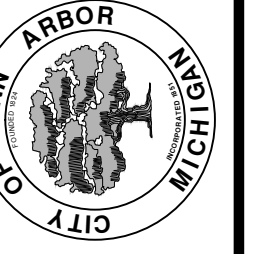

PROJECT MANAGEMENT - PUBLIC SERVICES - CITY OF ANN ARBOR
OBSERVATORY STREET IMPROVEMENT PROJECT

SCALE PLAN: NTS
DRAWING No. 2015025 - 7

S:\Project Management\Design\2015025 Observatory\Plan Production\2015025DET.dwg Dwg Created: 11-Dec-15 - a2 standard bw.stb - Plot Date: 12-Feb-16

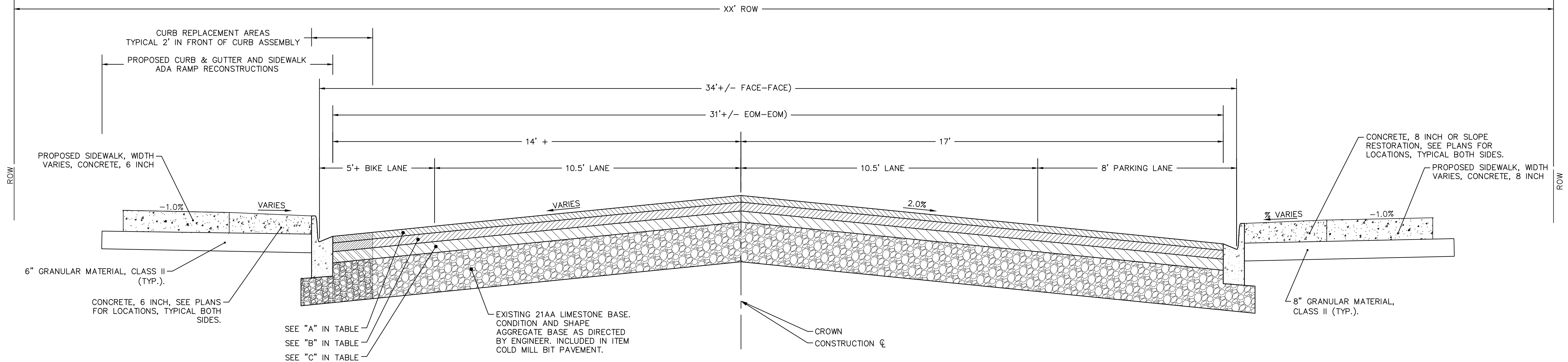

TYPICAL PAVEMENT SECTION
P.O.B. TO STA 15+50
N.T.S.

OBSERVATORY ST. PROPOSED CROSS SECTION

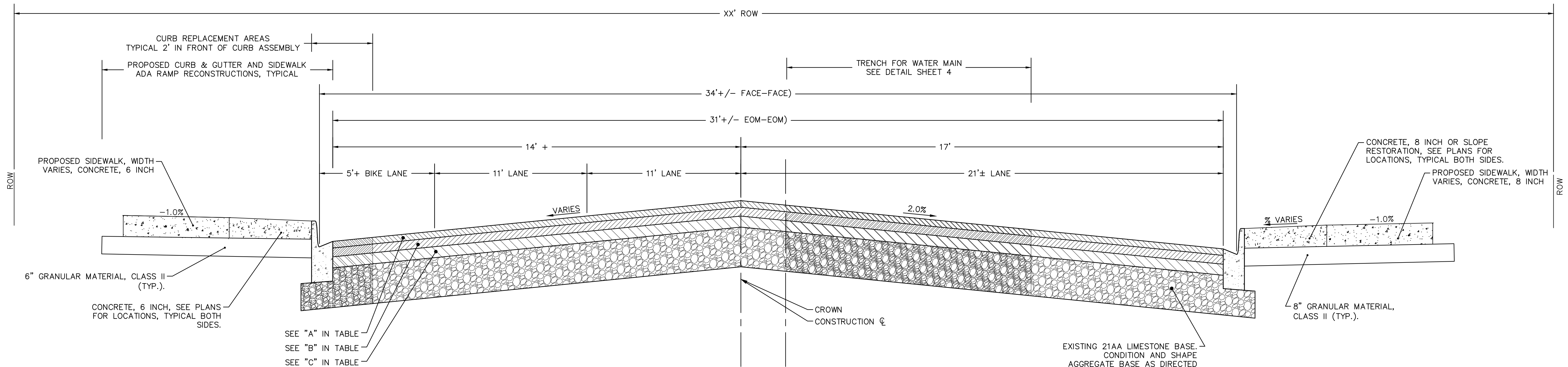

TYPICAL PAVEMENT SECTION
STA.15+50 TO P.O.E.
N.T.S.

OBSERVATORY ST. PROPOSED CROSS SECTION

TYPICAL ROAD CROSS SECTION APPLICATION TABLE						
ITEM	MIX	RATE OF APPLICATION	THICKNESS (INCHES)	AWI	BINDER	LOCATION/NOTES
A	HMA, 5E-10 HIGH STRESS	165 LB/SYD	1.5000	260	PG 64-28	WEARING COURSE
B	HMA, 4E-10 HIGH STRESS	220 LB/SYD	2.0000	-	PG 64-28	LEVELING COURSE
C	HMA, 3E-10	275 LB/SYD	2.5000	-	PG-58-22	BASE COURSE

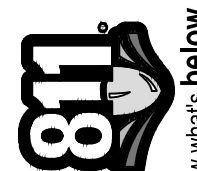

Know what's below. Call before you dig.

REV.	DATE	DESCRIPTION	DRAWN	CHECKED
02	2/09/2016	BID SET	JKA	IVK
01	11/05/2015	U OF M REVIEW	JKA	IVK
00	10/02/2015	PROJECT ENGINEER REVIEW	JKA	IVK



PROJECT MANAGEMENT - PUBLIC SERVICES - CITY OF ANN ARBOR
OBSERVATORY STREET IMPROVEMENT PROJECT

SCALE PLAN: NTS

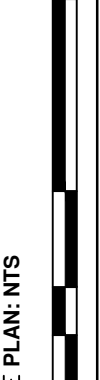

DRAWING No. 2015025 - 8

TYPICAL SECTIONS

SHEET No. 8 OF 40

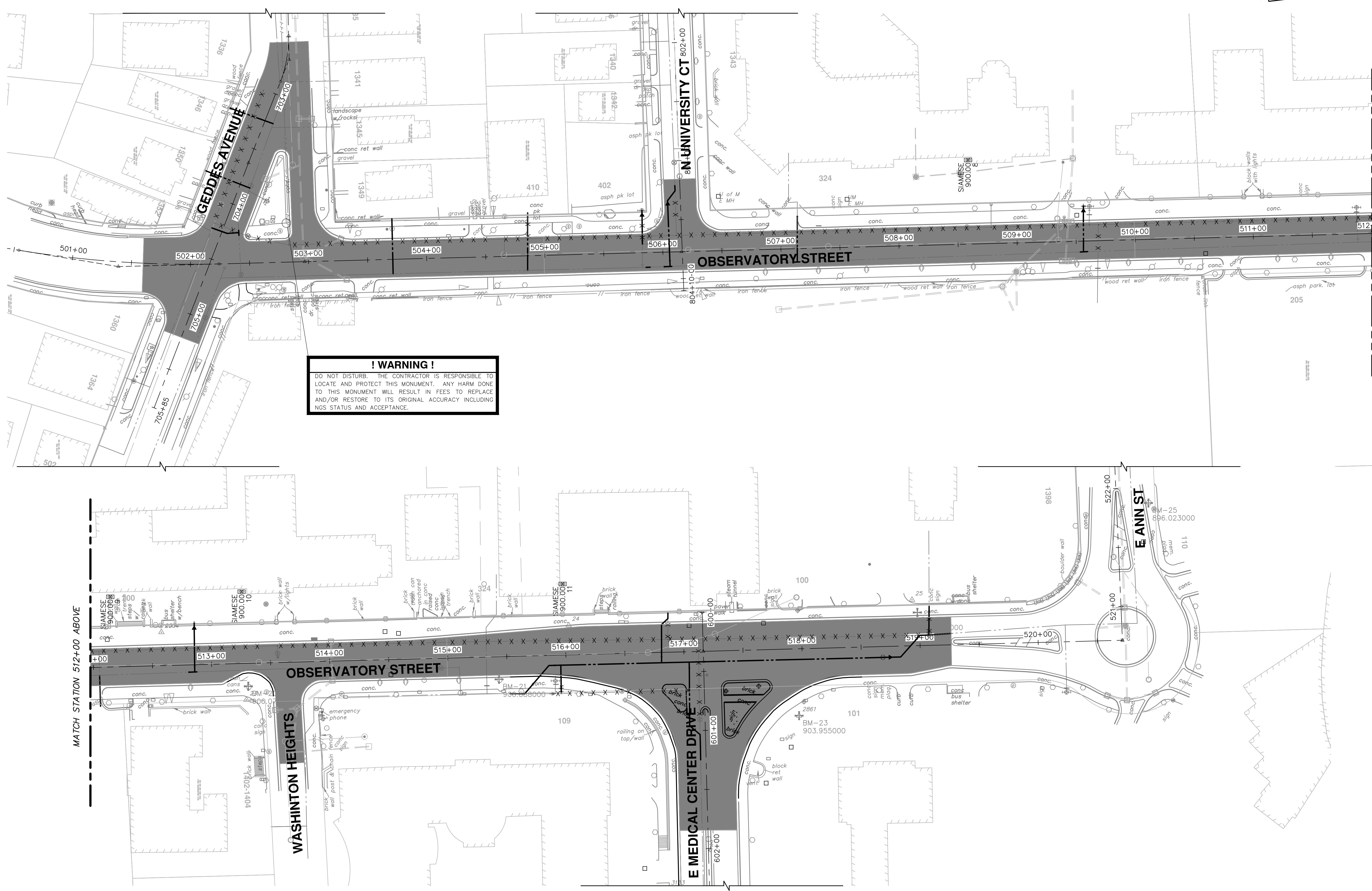

! WARNING !
 DO NOT DISTURB. THE CONTRACTOR IS RESPONSIBLE TO LOCATE AND PROTECT THIS MONUMENT. ANY HARM DONE TO THIS MONUMENT WILL RESULT IN FEES TO REPLACE AND/OR RESTORE TO ITS ORIGINAL ACCURACY INCLUDING NGS STATUS AND ACCEPTANCE.

MATCH STATION 512+00 BELOW

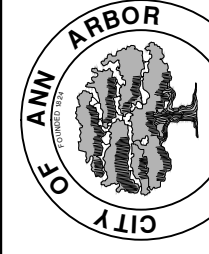

02	BID SET	2/09/2016	JKA	IVK
01	U OF M REVIEW	11/05/2015	JKA	IVK
00	PROJECT ENGINEER REVIEW	10/02/2015	JKA	IVK
	REV.	DATE	DRAWN	CHECKED



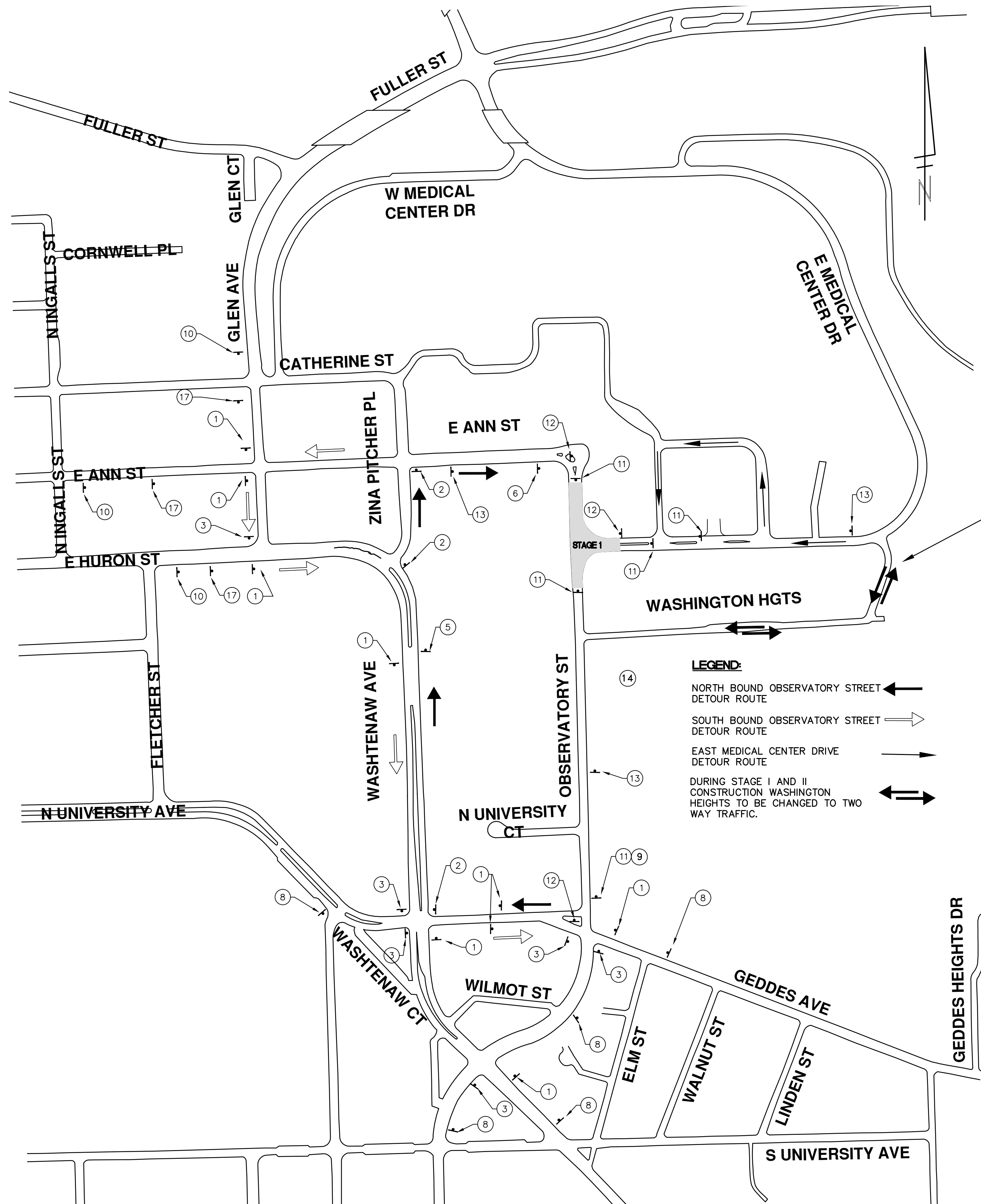

DETOUR CONSTRUCTION NOTES:

1. DEPENDING ON THE DETOUR ROUTES THAT ARE PUT IN PLACE, CONFLICTING SIGNS MAY BE PRESENT. PRIOR TO THE ORDERING OR PLACEMENT OF ANY SIGNS, MEET WITH THE ENGINEER TO VERIFY THE EXACT NUMBER AND LOCATION OF THE SIGNS TO BE PLACED. THE ENGINEER AND THE CONTRACTOR SHALL WORK TOGETHER TO ELIMINATE ALL CONFLICTS.
2. THE CITY RESERVES THE RIGHT TO ORDER ADDITIONAL SIGNS AND PLACE THEM INTO SERVICE IN ORDER TO SAFELY MAINTAIN TRAFFIC. ADJUSTMENTS IN THE UNIT PRICE FOR THESE ITEMS OF WORK SHALL NOT BE ALLOWED FOR THESE OCCURRENCES.
3. THE CONTRACTOR SHALL COORDINATE HIS OPERATIONS WITH THOSE OF THE CITY OF ANN ARBOR'S SIGNS AND SIGNALS UNIT DURING THE COURSE OF THE DETOUR ROUTE ESTABLISHMENT TO EFFECTIVELY AND SAFELY MAINTAIN TRAFFIC. DO NOT ERRECT ANY SIGNS UNTIL ITS LOCATION AND PROPOSED DATE OF INSTALLATION IS APPROVED BY THE ENGINEER.
4. THESE DETOURS ARE TO BE IN PLACE DURING OBSERVATORY STREET IMPROVEMENTS, AS DIRECTED BY THE ENGINEER, THE CONTRACTOR WILL CLOSE AND DETOUR SOUTH BOUND STONE SCHOOL ROAD TRAFFIC. SEE "DETAILED SPECIFICATION FOR MAINTAINING TRAFFIC AND CONSTRUCTION SEQUENCING" FOR DETAILS ON CONSTRUCTION STAGING, SEQUENCING, CLOSURE AND DETOUR LIMITATIONS, AND OTHER DETAILS.
5. REFERENCE THE "DETAILED SPECIFICATION FOR MAINTAINING TRAFFIC AND CONSTRUCTION SEQUENCING" FOR ADDITIONAL PROJECT REQUIREMENTS. THE CONTRACTOR'S ATTENTION IS SPECIFICALLY DIRECTED TO THE SECTION OF SAME SPECIAL PROVISION REGARDING COORDINATION WITH THE CITY SIGNS AND SIGNALS UNIT FOR THE SEVERAL DETOUR ROUTE MODIFICATIONS AND THE MODIFICATIONS TO TRAFFIC SIGNALS FOR THE DETOUR.
6. THE CONTRACTOR SHALL FURNISH, ERECT, AND MAINTAIN SIGNS AS SHOWN ON THE PLANS OR OTHERWISE DIRECTED BY THE ENGINEER.
7. CONSTRUCTION WARNING SIGNS SHALL HAVE AN ORANGE, HIGH-INTENSITY, REFLECTORIZED BACKGROUND.
8. SIGNS SHALL CONFORM TO THE 2011 MICHIGAN MANUAL OF UNIFORM TRAFFIC CONTROL DEVICES.
9. ADVANCE WARNING SIGNS SHALL BE PROVIDED WITH TWO (2) TYPE A FLASHING LIGHTS AND ONE (1) DAY-GLOW ORANGE FLAG.

TWO WAY TRAFFIC ON WASHINGTON HEIGHTS DURING STAGE 1 AND 2

SEQUENCE OF CONSTRUCTION

THE CONTRACTOR SHALL REVIEW THE TRAFFIC MAINTENANCE PLANS OF THE CONTRACT DOCUMENTS AND NOTE THAT EACH OF THE THREE CONSTRUCTION STAGES (1, 2, AND 2A) ARE PROVIDED TO MAINTAIN ACCESS AT ALL TIMES TO RESIDENCES SOLELY ACCESSED OFF OF OBSERVATORY STREET, AND MINIMIZE THE IMPACTS TO THE UNIVERSITY OF MICHIGAN AND HOSPITAL. CONTRACTOR IS REQUIRED TO MAINTAIN MAIL DELIVERY, REFUSE PICK UP AND ACCESS FOR EMERGENCY VEHICLES. THE DRIVEWAYS ARE TO BE MAINTAINED AT ALL TIMES. DURING CROSSING OF DRIVES WITH UTILITIES AND ROAD BUILDING, RESIDENTS MUST BE NOTIFIED AT LEAST A DAY IN ADVANCE SO VEHICLES CAN BE MOVED PRIOR TO THE CLOSURE. DRIVES ARE TO BE TEMPORARILY PUT BACK AS SOON AS POSSIBLE, AND OPENED FOR RESIDENT USE AT THE END OF EACH DAY. THE CONTRACTOR IS TO SUBMIT TO THE ENGINEER, A SEQUENCE OF CONSTRUCTION WITH RESPECT TO THE WATERMAIN CONNECTIONS AND INSTALLATIONS FOR REVIEW, COMMENT AND APPROVAL IN WRITING BY THE ENGINEER PRIOR TO CONSTRUCTION. THIS SCHEDULE IS TO INCLUDE ASSURANCE THAT ACCESS IS MAINTAINED AS DESCRIBED ABOVE. BELOW IS A SAMPLE SEQUENCE OF CONSTRUCTION WHICH THE CONTRACTOR MAY ADOPT OR CHOOSE TO ADJUST IN ORDER TO COMPLETE THE WORK MORE EFFICIENTLY.

SAMPLE CONSTRUCTION SEQUENCE - STAGE 1:
CONSTRUCT PROJECT FROM STATION 515+00 TO 519+50. INSTALL NEW 12 INCH WATER MAIN AND ROAD CROSS SECTION, PAVEMENT UP TO LEVELING COURSE AND PLACEMENT OF CURB AND SIDEWALK.

1. INSTALLATION OF TRAFFIC CONTROL DEVICES AND MAINTENANCE OF TRAFFIC PLAN FOR STAGE 1 MAINTENANCE OF TRAFFIC PLAN. INSTALLATION OF PORTABLE, CHANGEABLE MESSAGE SIGNS WITH MESSAGES AS DIRECTED BY THE ENGINEER ONE WEEK PRIOR TO CONSTRUCTION. INSTALLATION OF SOIL EROSION CONTROL DEVICES. PRIOR TO CONSTRUCTION ACTIVITIES STARTING HAVE ENTIRE SITE VIDEOTAPED.
2. REMOVAL OF PAVEMENT AND CONCRETE ITEMS NEEDED FOR PLACEMENT OF 12 INCH WATER MAIN. ADDITIONAL REMOVALS CAN BE DONE IF ACCESS STATED ABOVE IS MAINTAINED.
3. INSTALL 12 INCH WATER MAIN FROM STATION 515+50 TO 519+25.
4. WITH PASSING PRESSURE TEST ON WATER MAIN SCHEDULE AND MAKE CONNECTION OF NEW 12 INCH MAIN TO EXISTING 6 INCH MAIN AT STATION 519+25.
5. TEST WATER MAIN PER CITY DETAILED SPECIFICATION FOR WATER MAIN TESTING.
6. REMOVE AND REPLACE STORM STRUCTURES NOTED AND INSTALL EDGE DRAIN WERE CALLED OUT.
7. ONCE BACTERIOLOGICAL SAMPLES HAVE PASSED SCHEDULE WITH FIELD OPERATIONS AND TRANSFER 2 INCH SERVICES TO NEW MAIN AT 102 OBSERVATORY (DETROIT OBSERVATORY BUILDING)
8. SCHEDULE AND MAKE CONNECTIONS TO 4 INCH SERVICE TO 100 OBSERVATORY STREET (ALICE LLOYD HALL).
9. CONNECTION TO EXISTING 16 INCH ON OBSERVATORY STREET STATION 515+50 +/- AND EXISTING 12 INCH ON EAST MEDICAL CENTER DRIVE TO BE DONE AT SAME TIME, 8AM TO 5PM. PROVIDE 5 DAYS NOTICED OF PROPOSED SHUT DOWN SO NOTICE CAN BE GIVEN TO UNIVERSITY OF MICHIGAN HOSPITAL. WORK WILL REQUIRE 2 EXCAVATIONS AND COMPLETED IN SAME DAY BETWEEN HOURS OF 8AM AND 5PM. CONTRACTOR WILL BE REQUIRED TO HAVE MULTIPLE CREWS TO DO WATER MAIN CONNECTIONS SO SHUT DOWN CAN BE KEPT TO A MINIMUM.
10. ABANDON VALVE BOXES AND WELLS ON EXISTING 6 INCH WATER KEEPING MAIN IN SERVICE. FINAL KILL OF 6 INCH WILL BE DONE IN STAGE 2A.
11. FINISH REMOVAL OF HMA AND CONCRETE ITEMS STAGE 1.
12. EXCAVATE AND INSTALL ROAD CROSS SECTION INSTALLING SUBBASE AND AGGREGATE BASE COURSES.
13. PLACE EAST MEDICAL CENTER DRIVE INTERSECTION IMPROVEMENTS ALONG WITH CURB, DRIVEWAYS AND SIDEWALK.
14. FINE GRADE AGGREGATE BASE COURSE AND PLACE BASE AND LEVELING HMA COURSES. ADJUST MANHOLE STRUCTURES TO FINISH GRADE
15. TOPSOIL, SEED AND INSTALL MULCH BLANKETS AT ALL DISTURBED AREAS IN STAGE 1.
16. PLACE TEMPORARY PAVEMENT MARKINGS.
17. REMOVE STAGE 1 TRAFFIC CONTROL.

NOTE: THIS SEQUENCE IS FOR INFORMATION ONLY. IT IS INTENDED TO SHOW THE SEQUENCE OF CONSTRUCTION WITH RESPECT TO THE WATER MAIN CONNECTIONS AND INSTALLATIONS. THE CONTRACTOR IS RESPONSIBLE FOR SUBMITTING THEIR OWN DETAILED CONSTRUCTION SEQUENCE AND SCHEDULE TO THE ENGINEER FOR REVIEW, COMMENT, AND APPROVAL.

TRAFFIC CONTROL SIGN		
SIGN	NUMBER	QUANTITY
1 OBSERVATORY STREET	D3-1	9
1 DETOUR	M4-9S 30x24	9
2 OBSERVATORY STREET	D3-1	3
2 DETOUR	M4-9R 30x24	3
3 OBSERVATORY STREET	D3-1	6
3 DETOUR	M4-9L 30x24	6
4 OBSERVATORY STREET	D3-1	0
4 DETOUR	M4-9L (MOD.) 30x24	0
5 OBSERVATORY STREET	D3-1	1
5 DETOUR	M4-9L (MOD.) 30x24	1
6 OBSERVATORY STREET	D3-1	1
6 DETOUR ENDS	M4-8a 24x18	1
8 OBSERVATORY ST. CLOSED AT E. MEDICAL CENTER DR	SPECIAL 48x60	5
9 DETOUR	M4-10L 48x18	1
10 OBSERVATORY ST. CLOSED AT E. MEDICAL CENTER DR	SPECIAL 48x60	3
11 TYPE III BARRICADE WITH ROAD CLOSED TO THRU TRAFFIC	R11-3 60x30	5
12 SIGN, PORTABLE, CHANGEABLE MESSAGE		VERIFY EXACT QUANTITY AND LOCATION WITH ENGINEER PRIOR TO ORDERING
13 ROAD WORK AHEAD	W20-1 48 X 48	3
17 OBSERVATORY ST.	D3-1	3
17 DETOUR AHEAD	W20-2 48 X 48	3

PROJECT MANAGEMENT - PUBLIC SERVICES - CITY OF ANN ARBOR

OBSERVATORY STREET IMPROVEMENT PROJECT

DETOUR PLAN

STAGE 1

SCALE PLAN: 1" = 250'

DRAWING No. 2015025-10

SHEET No. 10 OF 40

CITY OF ANN ARBOR
PUBLIC SERVICES
301 EAST HURON STREET
PO BOX 8647
ANN ARBOR MI 48106-8647
www.aagov.org

REV.	DESCRIPTION	DATE	DRAWN	CHECKED
02	BID SET	2/09/2016	JKA	IVK
01	U OF M REVIEW	11/05/2015	JKA	IVK
00	PROJECT ENGINEER REVIEW	10/02/2015	JKA	IVK

S:\Project Management\Design\2015025 Observatory\Plan Production\2015025TRFC.dwg Dwg Created: 23-Oct-15 - _a2 standard bw.stb - Plot Date: 12-Feb-16

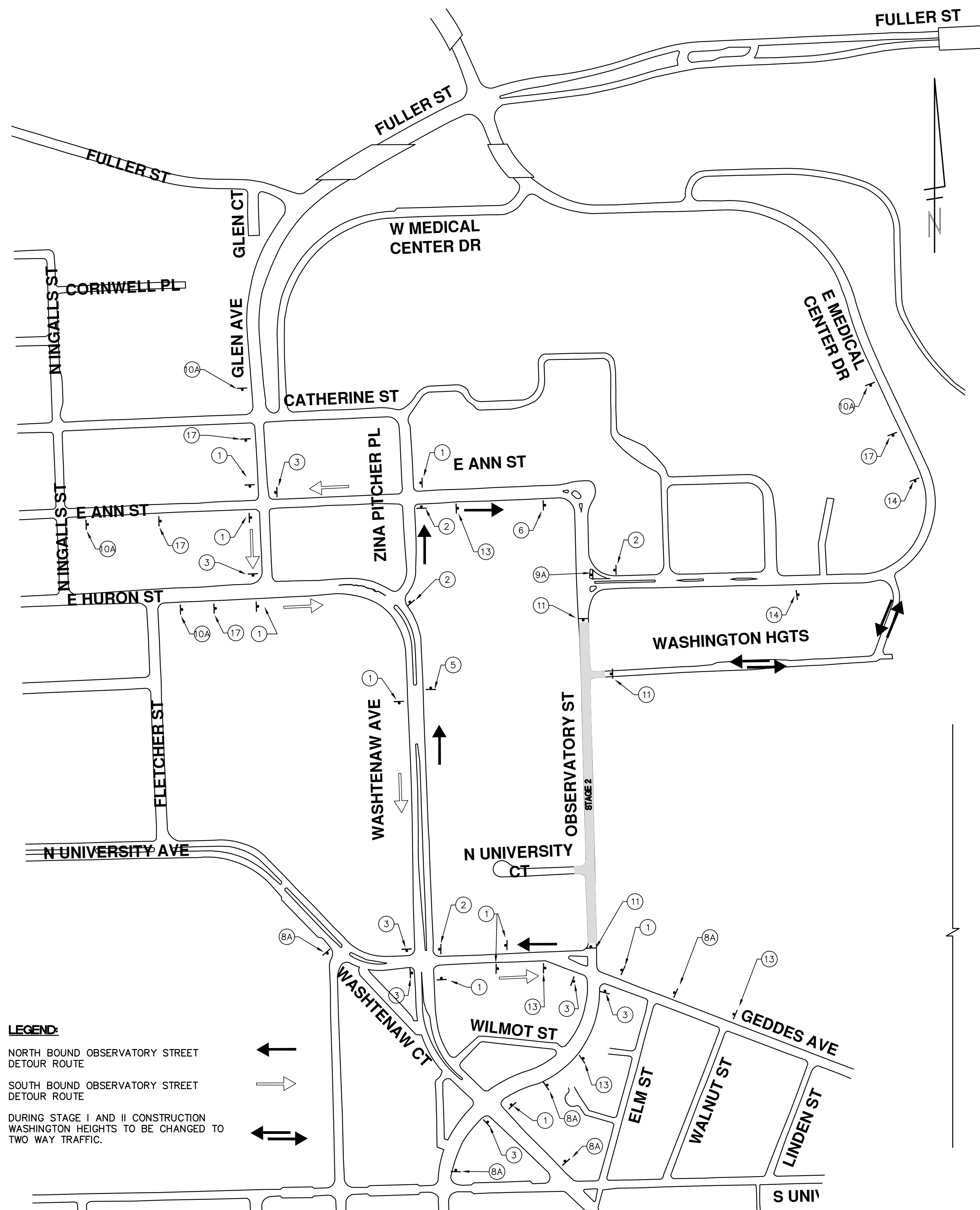

SEQUENCE OF CONSTRUCTION

THE CONTRACTOR SHALL REVIEW THE TRAFFIC MAINTENANCE PLANS OF THE CONTRACT DOCUMENTS AND NOTE THAT EACH OF THE THREE CONSTRUCTION STAGES (1, 2, AND 2A) ARE PROVIDED TO MAINTAIN ACCESS AT ALL TIMES TO RESIDENCES SOLELY ACCESSED OFF OF OBSERVATORY STREET, AND MINIMIZE THE IMPACTS TO THE UNIVERSITY OF MICHIGAN AND HOSPITAL. CONTRACTOR IS REQUIRED TO MAINTAIN MAIL DELIVERY, REFUSE PICK UP AND ACCESS FOR EMERGENCY VEHICLES. THE DRIVEWAYS ARE TO BE MAINTAINED AT ALL TIMES. DURING CROSSING OF DRIVES WITH UTILITIES AND ROAD BUILDING, RESIDENTS MUST BE NOTIFIED AT LEAST A DAY IN ADVANCE SO VEHICLES CAN BE MOVED PRIOR TO THE CLOSURE. DRIVES ARE TO BE TEMPORARILY PUT BACK AS SOON AS POSSIBLE, AND OPENED FOR RESIDENT USE AT THE END OF EACH DAY. THE CONTRACTOR IS TO SUBMIT TO THE ENGINEER, A SEQUENCE OF CONSTRUCTION WITH RESPECT TO THE WATERMAIN CONNECTIONS AND INSTALLATIONS FOR REVIEW, COMMENT AND APPROVAL IN WRITING BY THE ENGINEER PRIOR TO CONSTRUCTION. THIS SCHEDULE IS TO INCLUDE ASSURANCE THAT ACCESS IS MAINTAINED AS DESCRIBED ABOVE. BELOW IS A SAMPLE SEQUENCE OF CONSTRUCTION WHICH THE CONTRACTOR MAY ADOPT OR CHOOSE TO ADJUST IN ORDER TO COMPLETE THE WORK MORE EFFICIENTLY.

SAMPLE CONSTRUCTION SEQUENCE - STAGE 2:

CONSTRUCT PROJECT FROM STATION 503+50 TO 515+50. PLACE INLINE VALVE ON EXISTING 16 INCH WATER MAIN, TRANSFER EXISTING SERVICES FROM EXISTING 6 INCH WATER MAIN TO EXISTING 16 INCH WATER MAIN. INSTALL NEW ROAD CROSS SECTION ALONG WITH CURB, DRIVES, SIDEWALK AND PAVEMENT SECTION UP TO LEVELING COURSE.

- INSTALLATION OF TRAFFIC CONTROL DEVICES AND MAINTENANCE OF TRAFFIC PLAN FOR STAGE 2. CHANGE MESSAGE BOARDS LOCATION AND MESSAGE AS DIRECTED BY ENGINEER. INSTALL SOIL EROSION CONTROL DEVICES.
- REMOVAL OF PAVEMENT AND CONCRETE ITEMS NEEDED FOR TRANSFER OF EXISTING SERVICES AND NEW LATERALS TO 16 INCH. ADDITIONAL REMOVALS CAN BE DONE IF ACCESS STATED ABOVE IS MAINTAINED.
- 5 DAY NOTICE NEEDED FOR SHUT DOWN OF EXISTING 16 INCH WATER MAIN. SCHEDULE AND PLACE IN SAME DAY INLINE VALVE ON 16 INCH WATER MAIN, TEE AND VALVE FOR HYDRANT 1, AND TEE AND VALVE FOR UNIVERSITY COURT, 16 INCH INLINE VALVE AND TEE AND VALVE FOR HYDRANT 4. WORK WILL REQUIRE 3 EXCAVATIONS AND COMPLETED IN SAME DAY BETWEEN HOURS OF 8AM AND 5PM. CONTRACTOR WILL BE REQUIRED TO HAVE MULTIPLE CREWS TO DO WATER MAIN CONNECTIONS SO SHUT DOWN TIME CAN BE KEPT TO A MINIMUM. AREAS TO BE EXCAVATED THE DAY BEFORE AND MADE SAFE.
- INSTALL TAPPING SLEEVES WITH VALVES AND DUCTILE LEADS UP TO EXISTING 6 INCH WATER MAIN AT 4 INCH SERVICE TO STOCKWELL HALL AND FOR HYDRANT 4.
- EXTEND ALL DUCTILE SERVICES AND HYDRANT LEADS AS FAR AS POSSIBLE FOR PROPOSED CONNECTIONS. MAY BE ABLE TO PLACE NEW HYDRANTS WITHOUT REMOVING EXISTING ONES AND SHUTTING 6 INCH MAIN DOWN. THIS WILL BE DETERMINED IN THE FIELD PRIOR TO WORK BEING DONE.
- TRANSFER COPPER SERVICES FROM 6 INCH WATER MAIN TO 16 INCH WATER MAIN.
- SCHEDULE SHUT DOWN OF 6 INCH WATER MAIN AND CONNECT 4 INCH TO FOREST HILL CEMETERY, AND PLACEMENT OF HYDRANT 3 AND 4.
- SCHEDULE SHUT DOWN OF 6 INCH WATER MAIN AND CONNECT AT NORTH UNIVERSITY COURT, 4 INCH SERVICE TO STOCKWELL HALL AND H1 IF NOT ALREADY INSTALLED. CUT AND CAP EXISTING 6 INCH WITH THRUST BLOCK SOUTH OF 12 INCH WATER MAIN CROSSING TO N. UNIVERSITY COURT.
- ABANDON VALVE BOXES, WELLS AND HYDRANTS ON EXISTING 6 INCH WATER MAIN. FINAL KILL OF 6 INCH WILL BE DONE IN STAGE 2A.
- REMOVE AND REPLACE STORM STRUCTURES NOTED AND INSTALL EDGE DRAIN WHERE CALLED OUT.
- FINISH REMOVAL OF HMA AND CONCRETE ITEMS STAGE 2.
- EXCAVATE AND INSTALL ROAD CROSS SECTION INSTALLING SUBBASE AND AGGREGATE BASE COURSES.
- PLACE CONCRETE ITEMS CURB, SIDEWALK DRIVEWAYS.
- FINE GRADE AGGREGATE BASE COURSE AND PLACE BASE AND LEVELING HMA COURSES. ADJUST MANHOLE STRUCTURES TO FINISH GRADE.
- TOPSOIL, SEED AND INSTALL MULCH BLANKETS AT ALL DISTURBED AREAS IN STAGE 2.
- PLACE TEMPORARY PAVEMENT MARKINGS.
- REMOVE STAGE 2 TRAFFIC CONTROL.

NOTE: THIS SEQUENCE IS FOR INFORMATION ONLY. IT IS INTENDED TO SHOW THE SEQUENCE OF CONSTRUCTION WITH RESPECT TO THE WATER MAIN CONNECTIONS AND INSTALLATIONS. THE CONTRACTOR IS RESPONSIBLE FOR SUBMITTING THEIR OWN DETAILED CONSTRUCTION SEQUENCE AND SCHEDULE TO THE ENGINEER FOR REVIEW, COMMENT, AND APPROVAL.

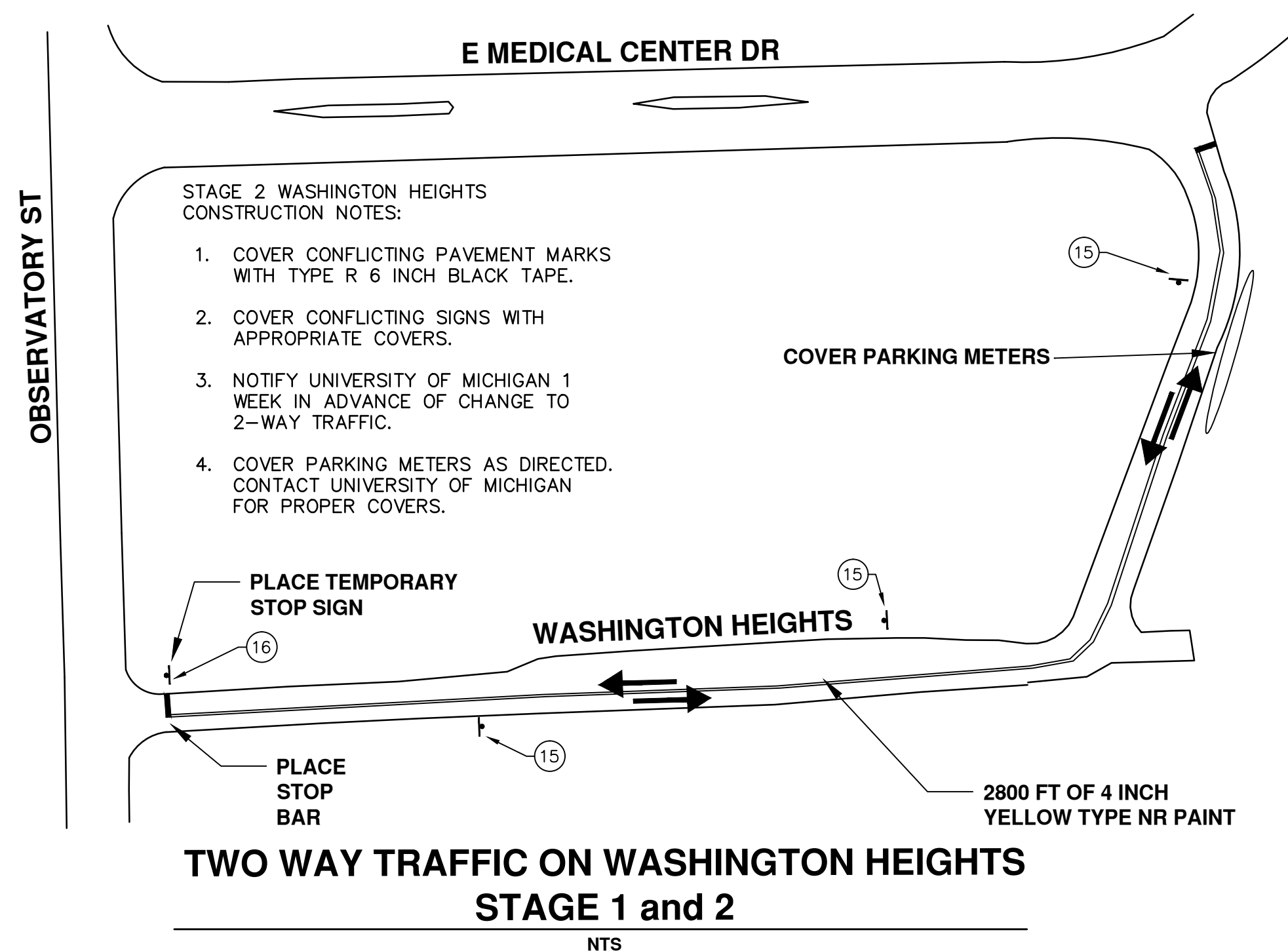

TRAFFIC CONTROL SIGN			
SIGN	NUMBER	QUANTITY	
1 OBSERVATORY STREET DETOUR	D3-1 M4-9S 30x24	9 9	
2 OBSERVATORY STREET DETOUR	D3-1 M4-9R 30x24	4 4	
3 OBSERVATORY STREET DETOUR	D3-1 M4-9L 30x24	7 7	
4 OBSERVATORY STREET DETOUR	D3-1 M4-9L (MOD.) 30x24		
5 OBSERVATORY STREET DETOUR	D3-1 M4-9L (MOD.) 30x24	1 1	
6 OBSERVATORY STREET DETOUR ENDS	D3-1 M4-8a 24x18	1 1	
8A OBSERVATORY ST. CLOSED AT GEDDES AVENUE	SPECIAL 48x60	5	
9A DETOUR	M4-10R 48x18	1	
10A OBSERVATORY ST. CLOSED AT WASHINGTON HEIGHTS	SPECIAL 48x60	4	
11 TYPE III BARRICADE WITH ROAD CLOSED TO THRU TRAFFIC	R11-3 60x30	3	
12 SIGN, PORTABLE, CHANGEABLE MESSAGE		x	
13 ROAD WORK AHEAD	W20-1 48 X 48	4	
14 OBSERVATORY ST.	D3-1	4	
14 2-WAY TRAFFIC ON WASHINGTON HEIGHTS DURING CONSTRUCTION	SPECIAL 48x60	2	
15	W6-3 36"x36"	3	
16 STOP	R1-1 36"x36"	1	
17	W20-2 48 X 48	4	

811
Know what's below.
Call Before you dig.

IVK	IVK	IVK	CHECKED
JKA	JKA	JKA	DRAWN
2/09/2016	11/05/2015	10/02/2015	DATE
BID SET	U OF M REVIEW	PROJECT ENGINEER REVIEW	DESCRIPTION
02	01	00	REV.

CITY OF ANN ARBOR
PUBLIC SERVICES
301 EAST HURON STREET
PO BOX 8647
ANN ARBOR MI 48106-8647
www.a2gov.org

ANN ARBOR MICHIGAN

PROJECT MANAGEMENT - PUBLIC SERVICES - CITY OF ANN ARBOR
OBSERVATORY STREET IMPROVEMENT PROJECT
DETOUR PLAN
STAGE 2

SCALE PLAN: 1" = 250'
DRAWING No. 2015025-11
SHEET No. 11 OF 40

STAGE 2A DETOUR CONSTRUCTION NOTES:

1. STAGE 2A CAN BE IMPLEMENTED ONLY WHEN STAGE 2 WORK COMPLETED OR AS DIRECTED BY ENGINEER.
2. STAGE 2 SIGNS TO BE ADJUSTED TO CORRESPOND WITH STAGE 2A MAINTENANCE OF TRAFFIC PLAN.
3. ENGINEER TO BE NOTIFIED 1 WEEK IN ADVANCE OF IMPLEMENTATION OF STAGE 2A. MESSAGE BOARDS TO BE CHANGED AT THIS TIME INFORMING PUBLIC OF DATE OF THIS CLOSURE.

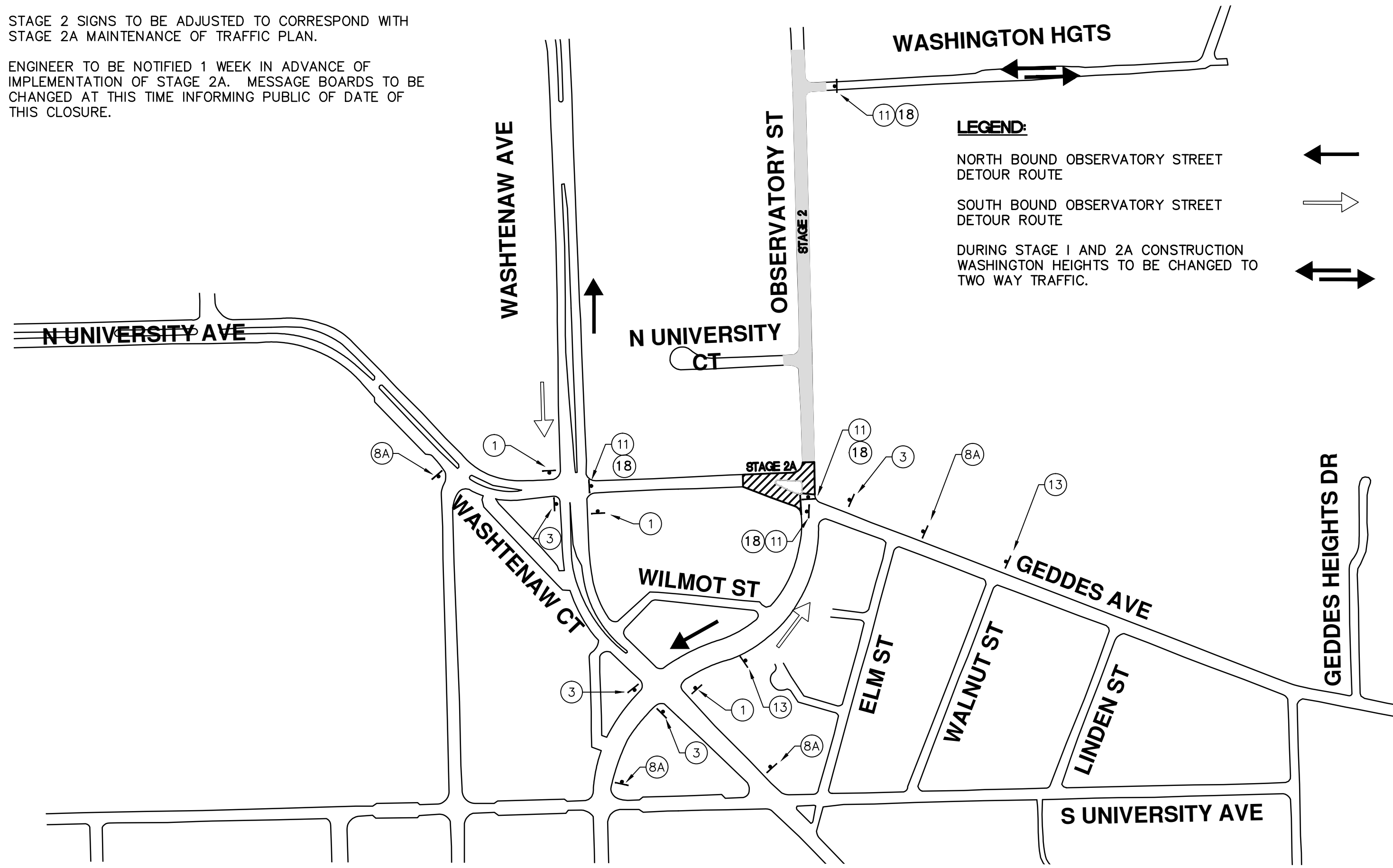

SEQUENCE OF CONSTRUCTION

THE CONTRACTOR SHALL REVIEW THE TRAFFIC MAINTENANCE PLANS OF THE CONTRACT DOCUMENTS AND NOTE THAT EACH OF THE THREE CONSTRUCTION STAGES (1, 2, AND 2A) ARE PROVIDED TO MAINTAIN ACCESS AT ALL TIMES TO RESIDENCES SOLELY ACCESSED OFF OF OBSERVATORY STREET, AND MINIMIZE THE IMPACTS TO THE UNIVERSITY OF MICHIGAN AND HOSPITAL. CONTRACTOR IS REQUIRED TO MAINTAIN MAIL DELIVERY, REFUSE PICK UP AND ACCESS FOR EMERGENCY VEHICLES. THE DRIVEWAYS ARE TO BE MAINTAINED AT ALL TIMES. DURING CROSSING OF DRIVES WITH UTILITIES AND ROAD BUILDING, RESIDENTS MUST BE NOTIFIED AT LEAST A DAY IN ADVANCE SO VEHICLES CAN BE MOVED PRIOR TO THE CLOSURE. DRIVES ARE TO BE TEMPORARILY PUT BACK AS SOON AS POSSIBLE, AND OPENED FOR RESIDENT USE AT THE END OF EACH DAY. THE CONTRACTOR IS TO SUBMIT TO THE ENGINEER, A SEQUENCE OF CONSTRUCTION WITH RESPECT TO THE WATERMAIN CONNECTIONS AND INSTALLATIONS FOR REVIEW, COMMENT AND APPROVAL IN WRITING BY THE ENGINEER PRIOR TO CONSTRUCTION. THIS SCHEDULE IS TO INCLUDE ASSURANCE THAT ACCESS IS MAINTAINED AS DESCRIBED ABOVE. BELOW IS A SAMPLE SEQUENCE OF CONSTRUCTION WHICH THE CONTRACTOR MAY ADOPT OR CHOOSE TO ADJUST IN ORDER TO COMPLETE THE WORK MORE EFFICIENTLY.

SAMPLE CONSTRUCTION SEQUENCE - STAGE 2A:

1. CONSTRUCT PROJECT FROM STATION 501+50 TO 503+50. CONNECT EXISTING 6 INCH TO 10 INCH WATER MAIN, TRANSFERS SERVICES TO 10 INCH WATER MAIN. INSTALL NEW ROAD CROSS SECTION ALONG WITH CURB, DRIVES, SIDEWALK AND PAVEMENT SECTION UP TO LEVELING COURSE. PAVE WEARING COURSE STAGE 1, 2 AND 2A. PLACE PERMANENT PAVEMENT MARKINGS.
2. INSTALLATION OF TRAFFIC CONTROL DEVICES AND MAINTENANCE OF TRAFFIC PLAN FOR STAGE 2A. CHANGE MESSAGE BOARDS LOCATION AND MESSAGE AS DIRECTED BY ENGINEER. INSTALL SOIL EROSION CONTROL DEVICES.
3. TRANSFER COPPER SERVICES TO 1346 AND 1350 GEDDES AVE FROM EXISTING 6 INCH TO EXISTING 10 INCH WATER MAIN.
4. SCHEDULE SHUT DOWN OF 10 INCH AND 6 INCH ON GEDDES AVE. LINE STOP WILL BE NEEDED ON 6 INCH ON GEDDES. CONNECT EXISTING 6 INCH TO EXISTING 10 INCH WERE MAINS CROSS STATION 502+07+/- . CUT AND CAP WITH THRUST BLOCK 6 INCH ON GEDDES WEST OF EXISTING TEE. REMOVE AND REPLACE STORM STRUCTURES NOTED AND INSTALL EDGE DRAIN WERE CALLED OUT.
5. FINISH REMOVAL OF HMA AND CONCRETE ITEMS STAGE 2.
6. EXCAVATE AND INSTALL ROAD CROSS SECTION INSTALLING SUBBASE AND AGGREGATE BASE COURSES.
7. PLACE CONCRETE ITEMS CURB, SIDEWALK DRIVEWAYS.
8. FINE GRADE AGGREGATE BASE COURSE AND PLACE BASE AND LEVELING HMA COURSES. ADJUST MANHOLE STRUCTURES TO FINISH GRADE.
9. TOPSOIL, SEED AND INSTALL MULCH BLANKETS AT ALL DISTURBED AREAS IN STAGE 2.
10. PAVE WEARING COURSE STAGE 1, 2 AND 2A. PLACE PERMANENT PAVEMENT MARKINGS.
11. REMOVE INLET FILTERS
12. REMOVE TRAFFIC CONTROL AND OPEN TO NORMAL TRAFFIC.

NOTE: THIS SEQUENCE IS FOR INFORMATION ONLY. IT IS INTENDED TO SHOW THE SEQUENCE OF CONSTRUCTION WITH RESPECT TO THE WATER MAIN CONNECTIONS AND INSTALLATIONS. THE CONTRACTOR IS RESPONSIBLE FOR SUBMITTING THEIR OWN DETAILED CONSTRUCTION SEQUENCE AND SCHEDULE TO THE ENGINEER FOR REVIEW, COMMENT, AND APPROVAL.

TRAFFIC CONTROL SIGN		
SIGN	NUMBER	QUANTITY
1. OBSERVATORY STREET DETOUR	D3-1	3
2. OBSERVATORY STREET DETOUR	M4-9S 30x24	3
3. OBSERVATORY STREET DETOUR	D3-1	4
3. OBSERVATORY STREET DETOUR	M4-9L 30x24	4
8A. OBSERVATORY ST. CLOSED AT GEDDES AVENUE	SPECIAL 48x60	4
11. TYPE III BARRICADE WITH ROAD CLOSED TO THRU TRAFFIC	R11-3 60x30	4
12. SIGN, PORTABLE, CHANGEABLE MESSAGE		
13. ROAD WORK AHEAD	W20-1 48 X 48	2
13. OBSERVATORY ST.	D3-1	2
18. ON CONSTRUCTION ORANGE	W1-7 48 X 24	4

PEDESTRIAN TRAFFIC CONTROL SIGNS			
SIGN	NUMBER	QUANTITY	TOTAL SFT
SIDEWALK CLOSED USE OTHER SIDE	R9-10 60X30	3	38
SIDEWALK CLOSED CROSS HERE	R9-11 60X30	3	38
SIDEWALK CLOSED	R9-9 30x18	3	14
SIDEWALK CLOSED AHEAD CROSS HERE	R9-11 48x36	3	36

SIDEWALK DETOUR

1. SIGNS PROVIDED AS NEEDED. PEDESTRIAN DETOUR PLACED AS DIRECTED BY ENGINEER

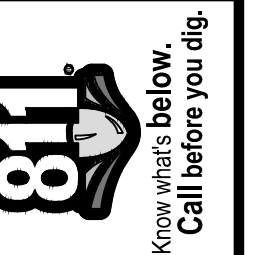
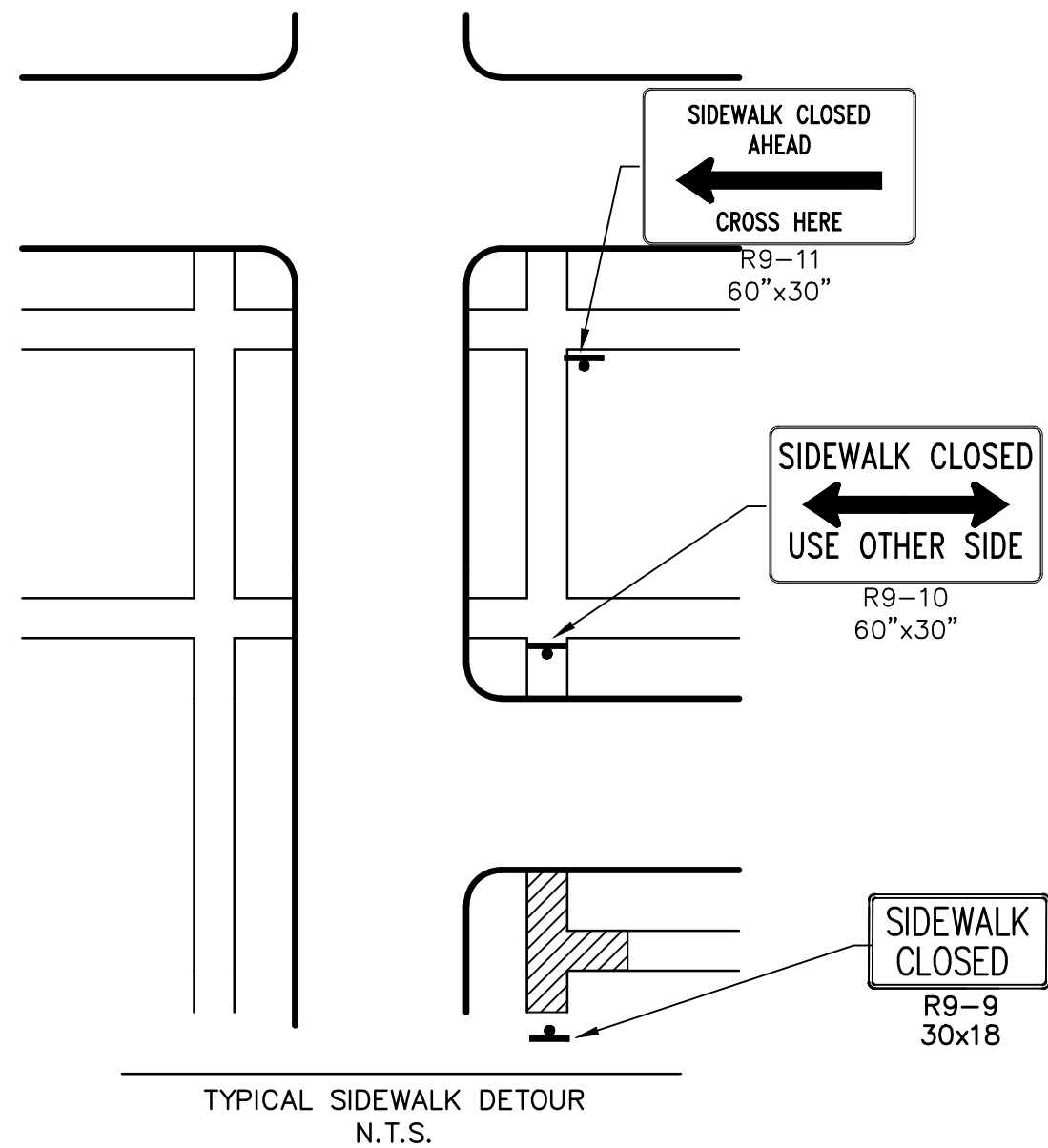

IVK	IVK	IVK	IVK	CHECKED
JKA	JKA	JKA	JKA	DRAWN
2/09/2016	11/05/2015	10/02/2015		DATE
U OF M REVIEW	PROJECT ENGINEER REVIEW			REV.

CITY OF ANN ARBOR
 PUBLIC SERVICES
 301 EAST HURON STREET
 P.O. BOX 8667
 ANN ARBOR MI 48107-8667
 www.a2gov.org

PROJECT MANAGEMENT - PUBLIC SERVICES - CITY OF ANN ARBOR
 Observatory Street Improvement Project
 DETOUR PLAN
 Stage 2A

SCALE PLAN: 1" = 250'
 DRAWING No. 2015025-12

S:\Project Management\Design\2015025 Observatory\Plan Production\2015025REM.dwg Dwg Created: 31-Aug-15 - 02 standard bw.stb - Plot Date: 12-Feb-16

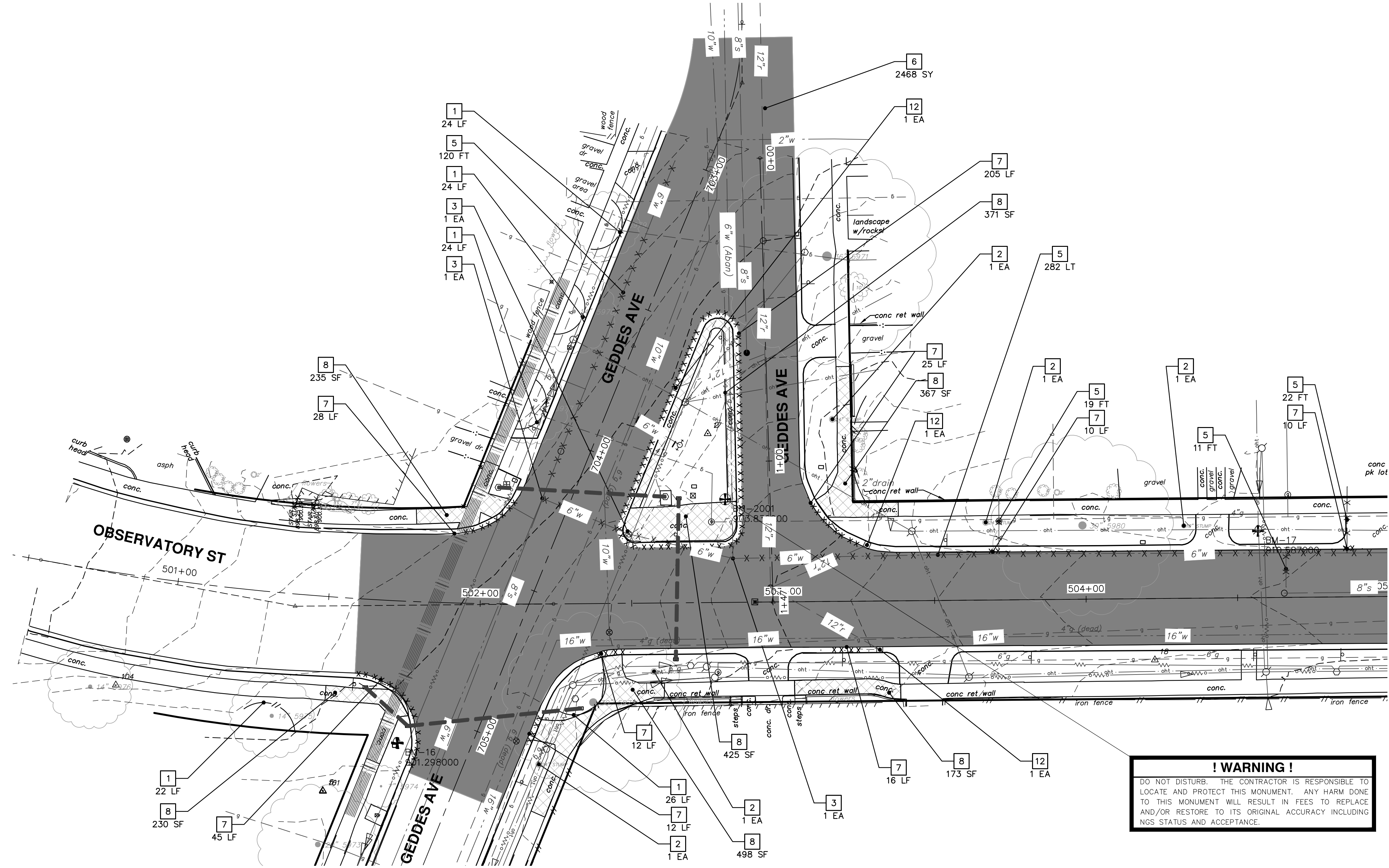

! WARNING !
 DO NOT DISTURB. THE CONTRACTOR IS RESPONSIBLE TO LOCATE AND PROTECT THIS MONUMENT. ANY HARM DONE TO THIS MONUMENT WILL RESULT IN FEES TO REPLACE AND/OR RESTORE TO ITS ORIGINAL ACCURACY INCLUDING NGS STATUS AND ACCEPTANCE.

REMOVAL KEY	
KEY	DESCRIPTION
1	PROTECTIVE FENCE
2	STUMP REMOVAL, 8" AND LARGER
3	REMOVE WATER VALVE OR FITTING
4	FIRE HYDRANT ASSEMBLY REMOVE
5	WATER MAIN PIPE ABANDONMENT - SEE NOTES SHEET XX-XX
6	REMOVE BITUMINOUS PAVEMENT*
7	REMOVE CONCRETE CURB AND GUTTER - ANY TYPE*
8	REMOVE CONCRETE SIDEWALK - ANY THICKNESS*
9	REMOVE CONCRETE DRIVEWAY - ANY THICKNESS*
10	REMOVE BRICK PAVERS - ANY THICKNESS*
11	REMOVE CONCRETE FOUNDATION - ANY SIZE*
12	REMOVE INLET STRUCTURE - ANY SIZE*
RBO	FIXTURES TO BE REMOVED BY OTHERS

*SAWCUT HMA FULL DEPTH AT REMOVAL LIMITS

SEE SHEET 14 STA:505+00



REV.	DATE	DESCRIPTION
01	11/05/2015	U OF M REVIEW
00	10/02/2015	PROJECT ENGINEER REVIEW

CITY OF ANN ARBOR
 PUBLIC SERVICE
 301 EAST HURON STREET
 ANN ARBOR, MI 48106-8647
 ANN ARBOR 734.764.4410
 www.a2gov.org



PROJECT MANAGEMENT - PUBLIC SERVICES - CITY OF ANN ARBOR
OBSERVATORY STREET IMPROVEMENT PROJECT
 REMOVALS
 GEDDES

SCALE PLAN: 1" = 20'
 DRAWING No. 2015025-13

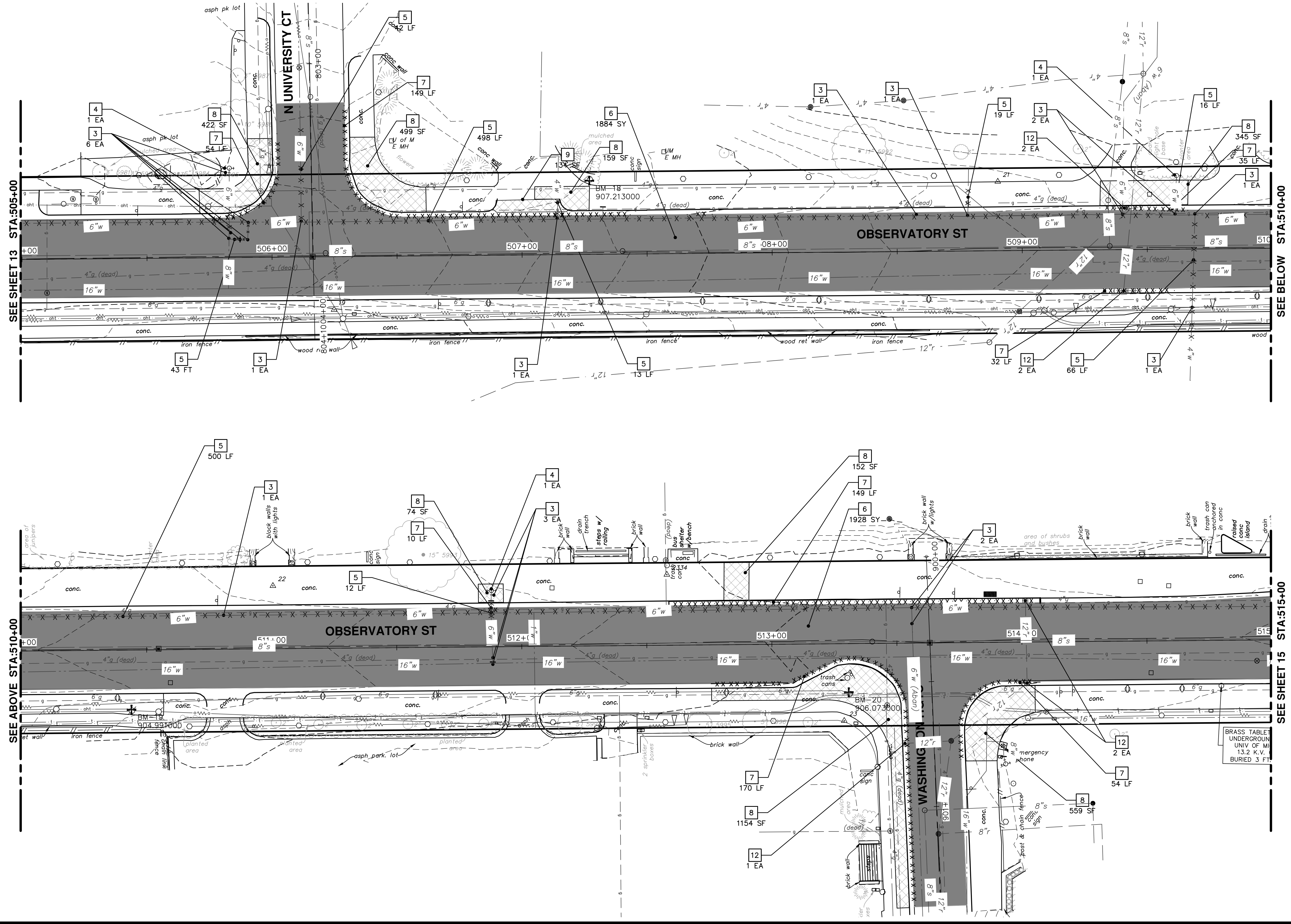

REMOVAL KEY	
KEY	DESCRIPTION
1	PROTECTIVE FENCE
2	STUMP REMOVAL, 8" AND LARGER
3	REMOVE WATER VALVE OR FITTING
4	FIRE HYDRANT ASSEMBLY REMOVE
5	WATER MAIN PIPE ABANDONMENT - SEE NOTES SHEET XX-XX
6	REMOVE BITUMINOUS PAVEMENT*
7	REMOVE CONCRETE CURB AND GUTTER - ANY TYPE*
8	REMOVE CONCRETE SIDEWALK - ANY THICKNESS*
9	REMOVE CONCRETE DRIVEWAY - ANY THICKNESS*
10	REMOVE BRICK PAVERS - ANY THICKNESS*
11	REMOVE CONCRETE FOUNDATION - ANY SIZE*
12	REMOVE INLET STRUCTURE - ANY SIZE*
RBO	FIXTURES TO BE REMOVED BY OTHERS

*SAWCUT HMA FULL DEPTH AT REMOVAL LIMITS

PROJECT MANAGEMENT - PUBLIC SERVICES - CITY OF ANN ARBOR

OBSERVATORY STREET IMPROVEMENT PROJECT

REMOVALS

OBSERVATORY 505+00 TO 515+00

SCALE PLAN: 1" = 20'

DRAWING No. 2015025-14

SHEET No. 14 OF 40

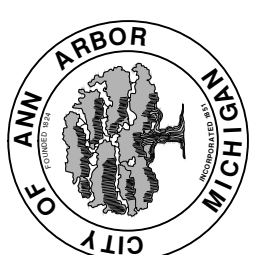

CITY OF ANN ARBOR
PUBLIC SERVICES
301 EAST HURON STREET
ANN ARBOR MI 48106-0667
www.a2gov.org

11/05/2015
10/02/2015
DATE

U OF M REVIEW
PROJECT ENGINEER REVIEW
REV.

IVK
JKA
JKA
DRAWN
CHECKED

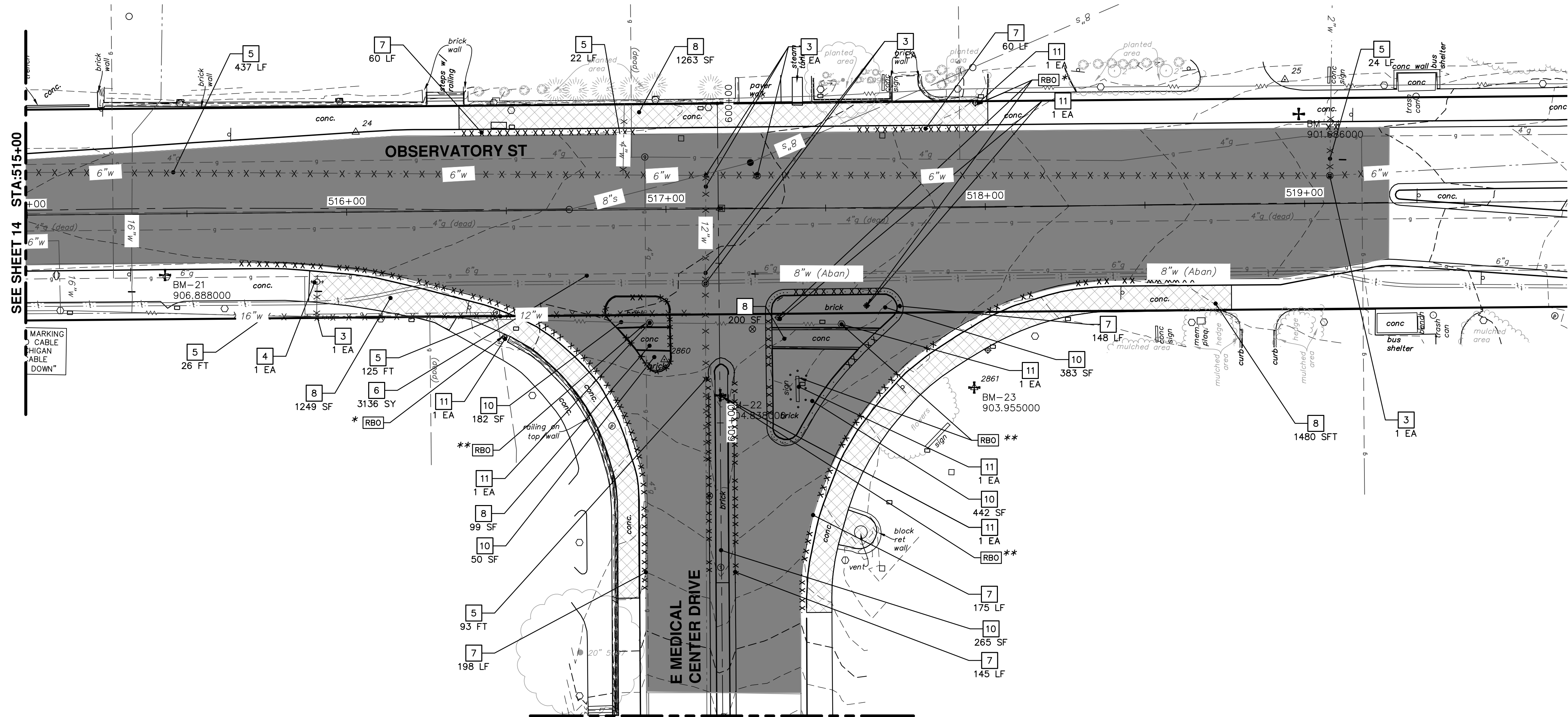

REMOVAL KEY	
KEY	DESCRIPTION
1	PROTECTIVE FENCE
2	STUMP REMOVAL, 8" AND LARGER
3	REMOVE WATER VALVE OR FITTING
4	FIRE HYDRANT ASSEMBLY REMOVE
5	WATER MAIN PIPE ABANDONMENT - SEE NOTES SHEET XX-XX
6	REMOVE BITUMINOUS PAVEMENT*
7	REMOVE CONCRETE CURB AND GUTTER - ANY TYPE*
8	REMOVE CONCRETE SIDEWALK - ANY THICKNESS*
9	REMOVE CONCRETE DRIVEWAY - ANY THICKNESS*
10	REMOVE BRICK PAVERS - ANY THICKNESS*
11	REMOVE CONCRETE FOUNDATION - ANY SIZE*
12	REMOVE INLET STRUCTURE - ANY SIZE*
RBO	FIXTURES TO BE REMOVED BY OTHERS

*SAWCUT HMA FULL DEPTH AT REMOVAL LIMITS

- NOTES:
- * CORRDINATE WITH CITY OF ANN ARBOR SIGNS AND SIGNALS FOR TRAFFIC SIGNALS TO BE DE-ENERGIZED AND FIXTURE REMOVAL.
 - ** CORRDINATE WITH UNIVERSITY OF MICHIGAN FOR STREET LIGHTS TO BE DE-ENERGIZED AND FIXTURE REMOVAL.

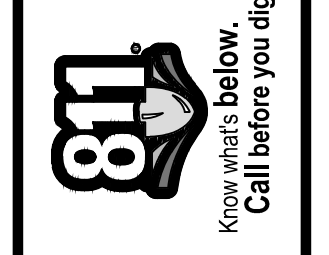

01	U OF M REVIEW	11/05/2015	JKA	IVK
00	PROJECT ENGINEER REVIEW	10/02/2015	JKA	IVK
	REV.	DATE	DESCRIPTION	CHECKED

CITY OF ANN ARBOR
 PUBLIC SERVICE
 301 EAST HURON STREET
 P.O. BOX 86400
 ANN ARBOR MI 48108-8647
 www.a3gov.org

PROJECT MANAGEMENT - PUBLIC SERVICES - CITY OF ANN ARBOR
 OBSERVATORY STREET IMPROVEMENT PROJECT
 REMOVALS
 OBSERVATORY 515+00 TO POE

SCALE PLAN: 1" = 20'
 DRAWING No. 2015025-15

S:\Project Management\Design\2015025 Observatory\Plan Production\2015025WATR.dwg Dwg Created: 1-Sep-15 - _a2 standard bw.stb - Plot Date: 12-Feb-16

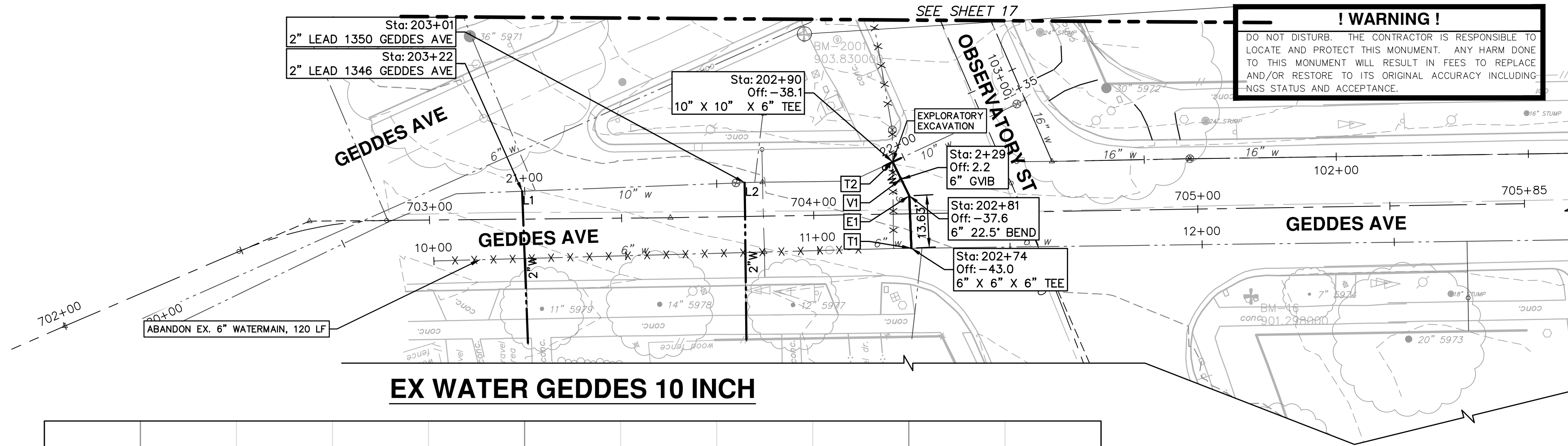

EX WATER GEDDES 10 INCH

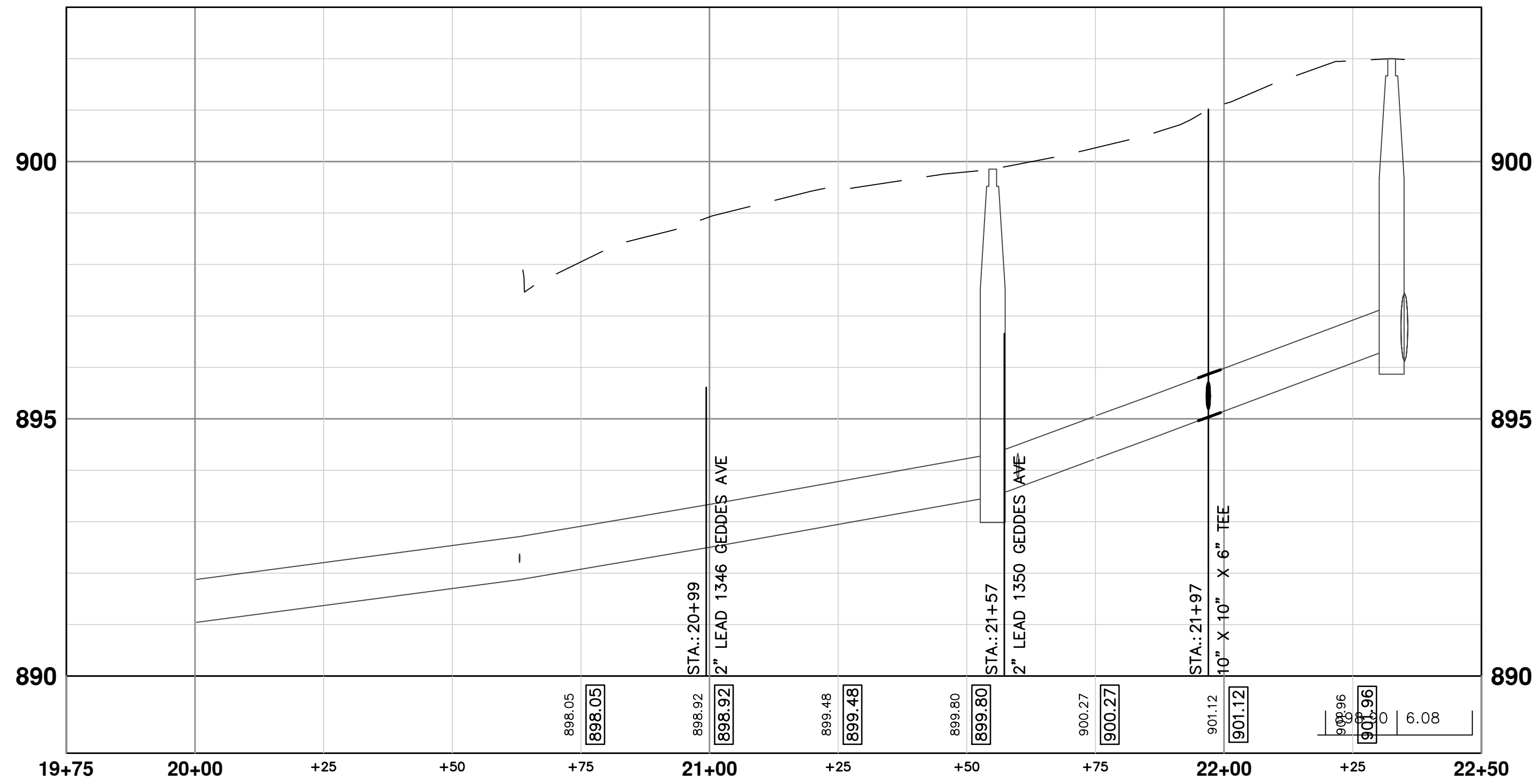

WATER MAIN STRUCTURE TABLE

STRUCTURE	TYPE	STATION	ALIGNMENT	RIM	DEPTH
V1	6" GVIB	2+29	Ex Water Observatory	900.81	5.75
T1	6" X 6" X 6" TEE	202+74	Pr Water Observatory Project	899.69	4.95
LS1	6" LINE STOP	202+74	Pr Water Observatory Project	0.32	???
CC1	CUT AND CAP 6" WATER MAIN	202+74	Pr Water Observatory Project	0.32	???
E1	6" 22.5' BEND	202+81	Pr Water Observatory Project	900.60	5.61
T2	10" X 10" X 6" TEE	202+90	Pr Water Observatory Project	901.02	6.05
L2	2" LEAD 1350 GEDDES AVE	203+01	Pr Water Observatory Project	899.90	5.98
L1	2" LEAD 1346 GEDDES AVE	203+22	Pr Water Observatory Project	898.90	6.08

EX WATER OBSERVATORY

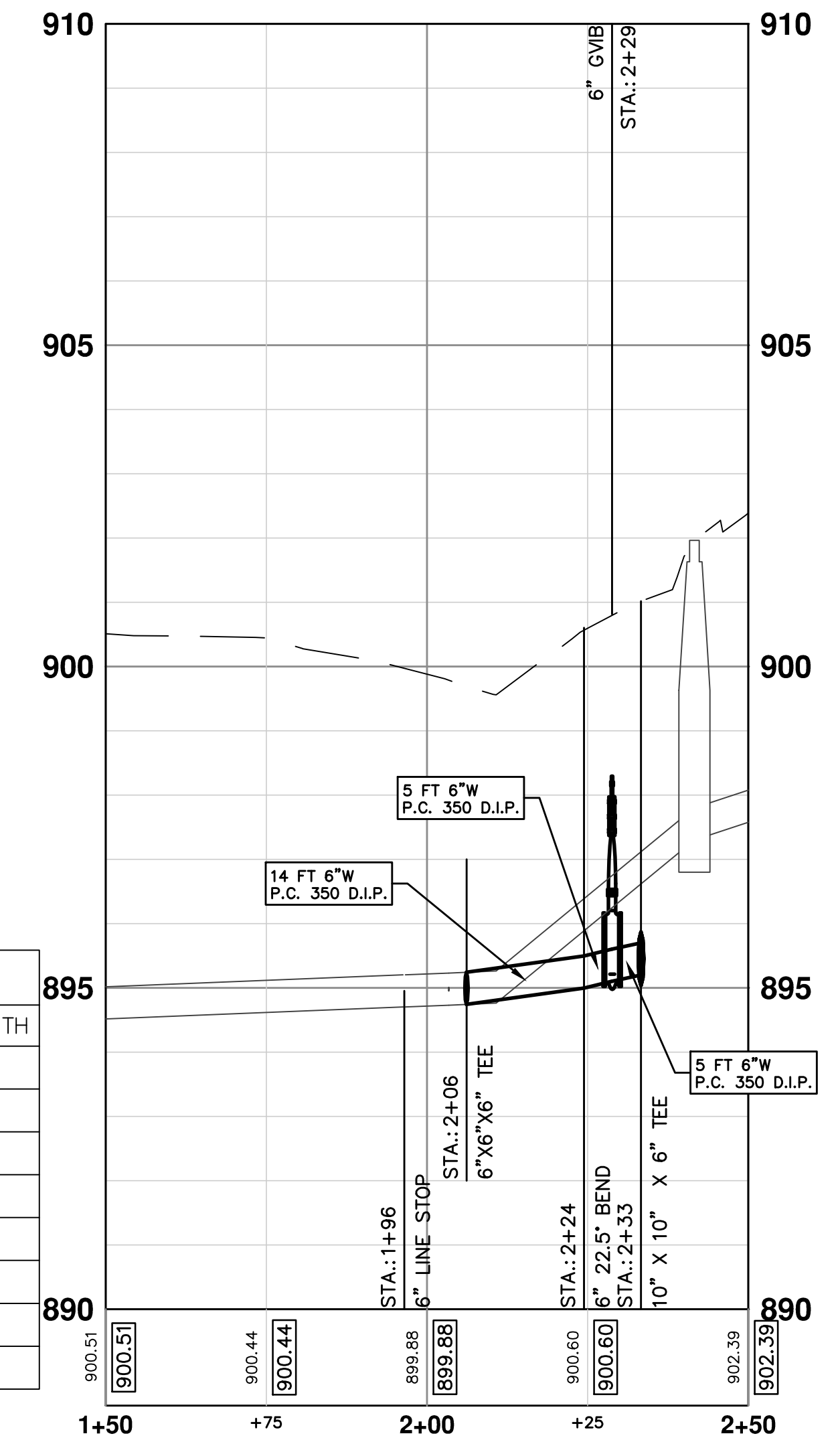

EX WATER OBSERVATORY 16 INCH

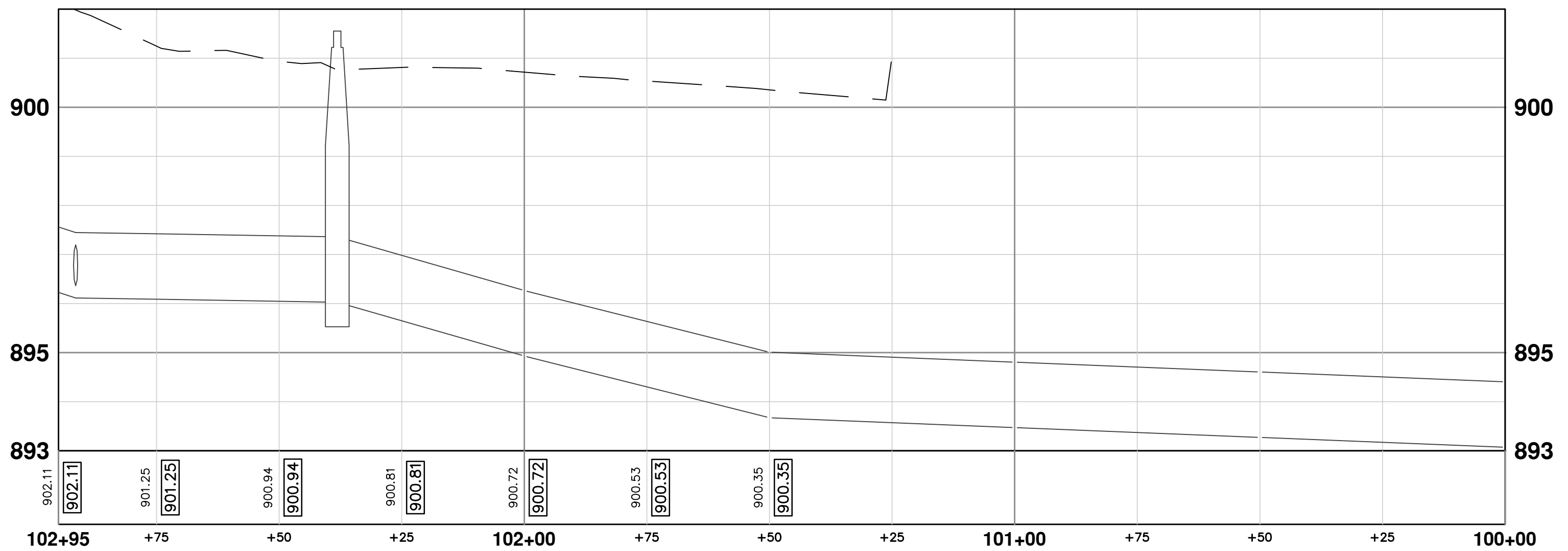

EX WATER GEDDES 6 INCH

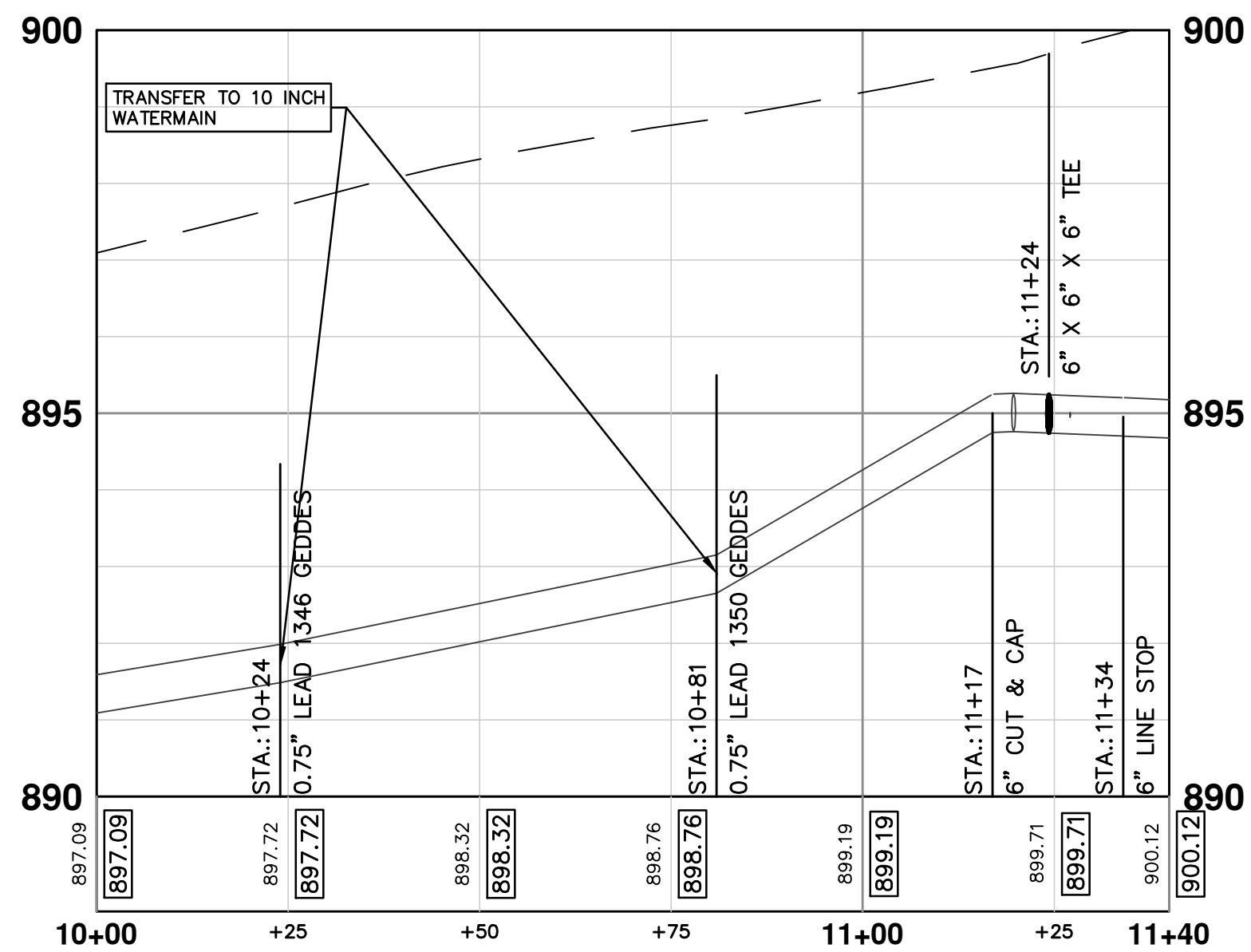

NOTE:
ALL WATER MAIN CONSTRUCTION SHALL HAVE RESTRAINED JOINTS.

811 Know what's below. Call before you dig.

CITY OF ANN ARBOR PUBLIC SERVICES
301 EAST HURON STREET
ANN ARBOR MI 48106-8647
www.a3gov.org

PROJECT MANAGEMENT - PUBLIC SERVICES - CITY OF ANN ARBOR
OBSERVATORY STREET IMPROVEMENT PROJECT
WATER
GEDDES TO 102+95

SCALE PLAN: 1" = 20'
PROFILE: 1" = 2'

DRAWING No. 2015025-16

SHEET No. 16 OF 40

REV.	DATE	DESCRIPTION
01	11/05/2015	U OF M REVIEW
00	10/02/2015	PROJECT ENGINEER REVIEW

S:\Project Management\Design\2015025 Observatory\Plan Production\2015025WATR.dwg Dwg Created: 1-Sep-15 - _a2 standard bw.stb - Plot Date: 12-Feb-16

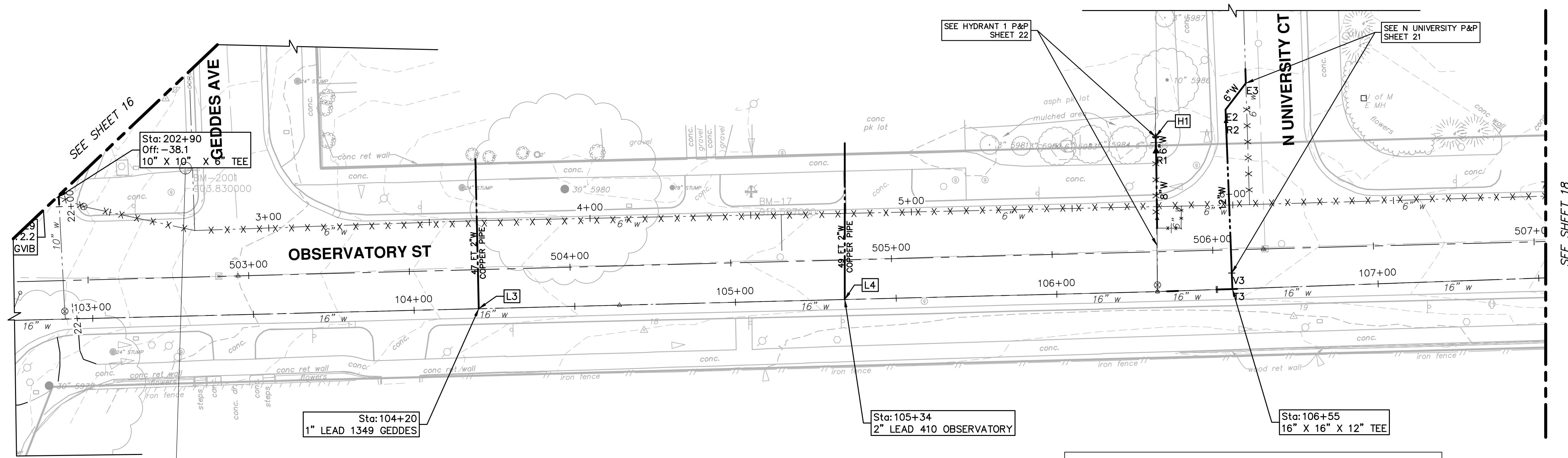

! WARNING !
DO NOT DISTURB. THE CONTRACTOR IS RESPONSIBLE TO LOCATE AND PROTECT THIS MONUMENT. ANY HARM DONE TO THIS MONUMENT WILL RESULT IN FEES TO REPLACE AND/OR RESTORE TO ITS ORIGINAL ACCURACY INCLUDING NGS STATUS AND ACCEPTANCE.

WATER MAIN STRUCTURE TABLE					
STRUCTURE	TYPE	STATION	RIM	DEPTH	
L3	1" LEAD 1349 GEDDES	104+20	907.40	6.44	
L4	2" LEAD 410 OBSERVATORY	105+34	909.13	6.27	
T3	16" X 16" X 12" TEE	106+55	909.11	7.14	

NOTE:
ALL WATER MAIN CONSTRUCTION SHALL HAVE RESTRAINED JOINTS.

EX WATER OBSERVATORY 16 INCH

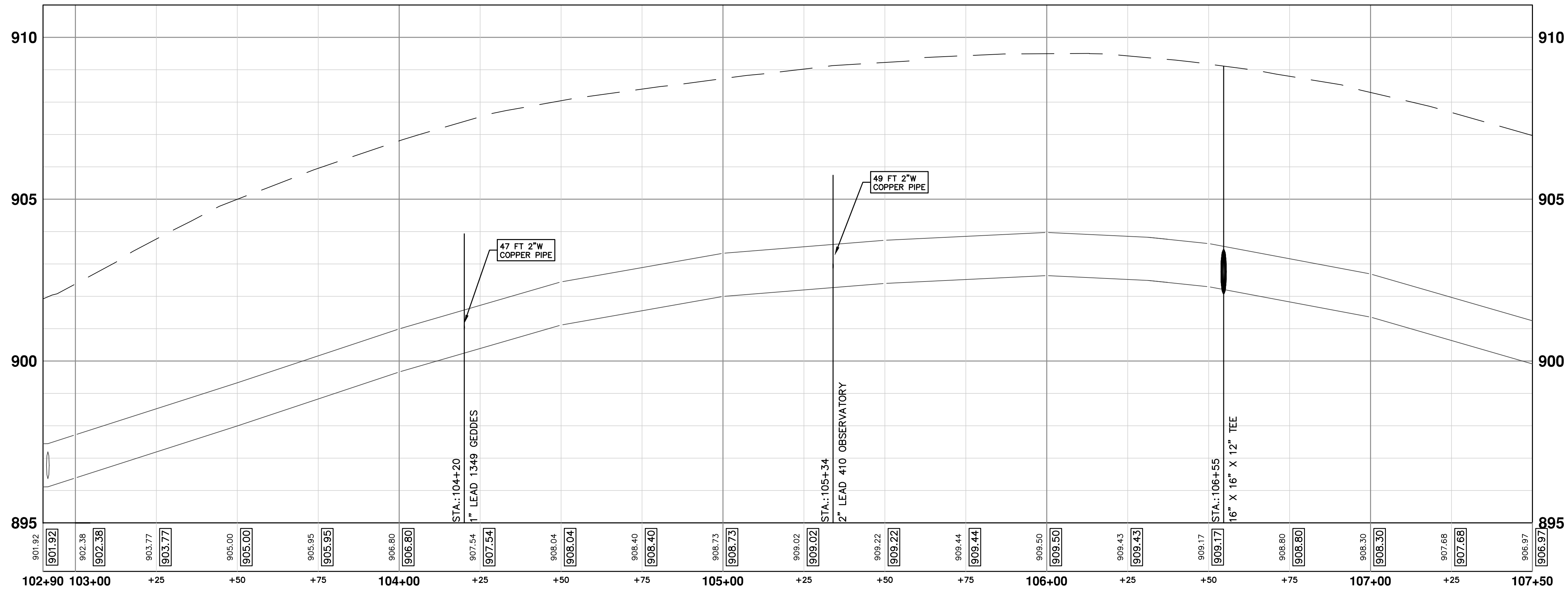

Know what's below. Call before you dig.

REV.	DESCRIPTION	DATE	DRAWN	CHECKED
01	U OF M REVIEW	11/05/2015	JKA	IVK
00	PROJECT ENGINEER REVIEW	10/02/2015	JKA	IVK

CITY OF ANN ARBOR
PUBLIC SERVICES
301 EAST HURON STREET
ANN ARBOR MI 48106-1667
www.a2gov.org

PROJECT MANAGEMENT - PUBLIC SERVICES - CITY OF ANN ARBOR
OBSERVATORY STREET IMPROVEMENT PROJECT
WATER
OBSERVATORY 102+90 TO 107-50

SCALE PLAN: 1" = 20'
PROFILE: 1" = 2'
DRAWING No. 2015025-17

SHEET No. 17 OF 40

S:\Project Management\Design\2015025 Observatory\Plan Production\2015025WATR.dwg Dwg Created: 1-Sep-15 - _a2 standard bw.stb - Plot Date: 12-Feb-16

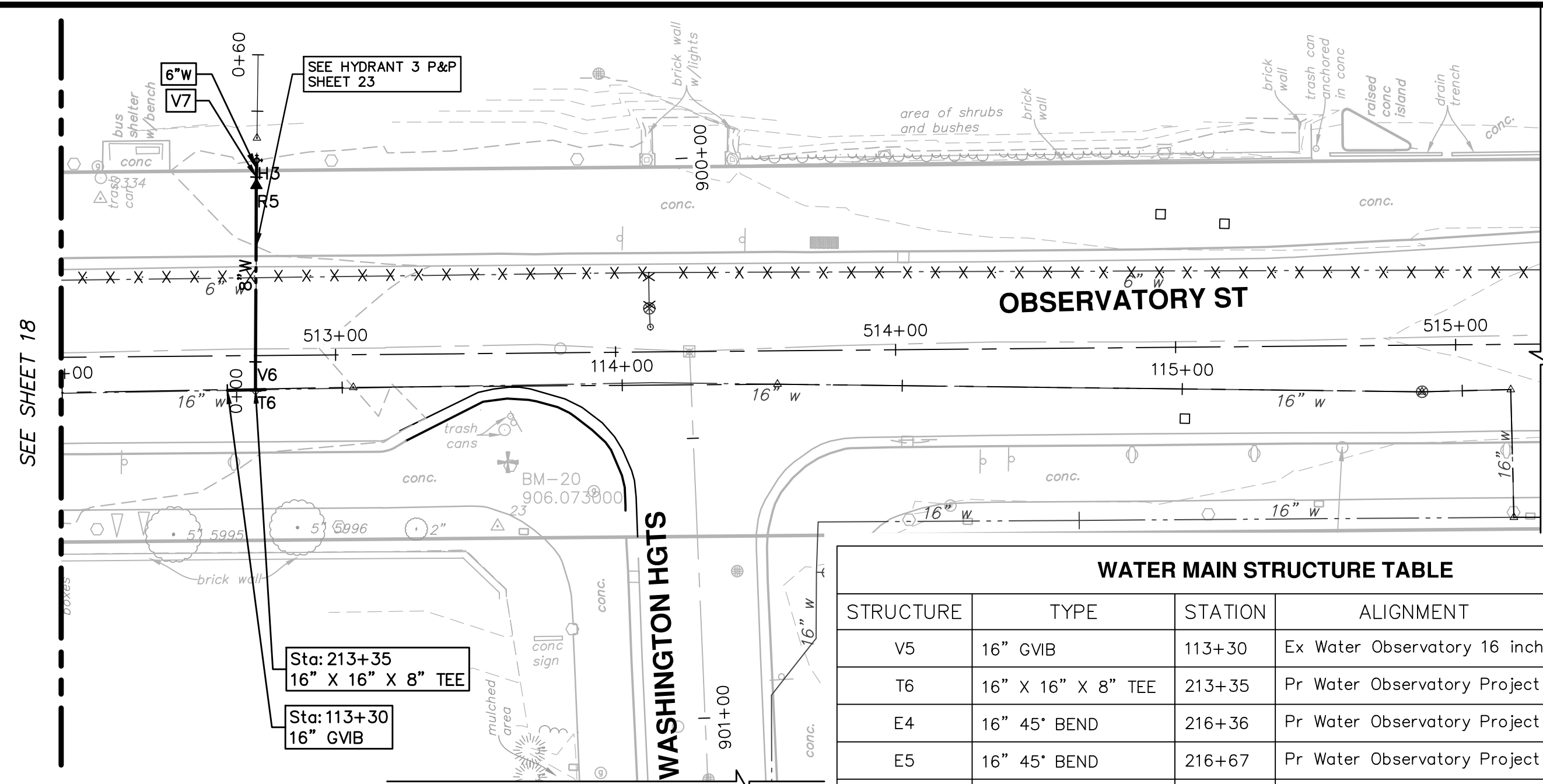

WATER MAIN STRUCTURE TABLE					
STRUCTURE	TYPE	STATION	ALIGNMENT	RIM	DEPTH
V5	16" GVIB	113+30	Ex Water Observatory 16 inch	905.45	7.65
T6	16" X 16" X 8" TEE	213+35	Pr Water Observatory Project	904.73	7.14
E4	16" 45° BEND	216+36	Pr Water Observatory Project	906.73	7.19
E5	16" 45° BEND	216+67	Pr Water Observatory Project	906.23	6.83
V8	16" GVIB	216+72	Pr Water Observatory Project	906.23	6.84
T8	16" X 16" X 8" TEE	216+77	Pr Water Observatory Project	906.23	6.86
T9	16" X 16" X 4" TEE	217+63	Pr Water Observatory Project	905.55	7.07
V12	16" GVIB	217+99	Pr Water Observatory Project	905.08	6.73
T10	16" X 16" X 12" TEE	600+42	E Medical	905.24	6.89

EX WATER OBSERVATORY 16 INCH

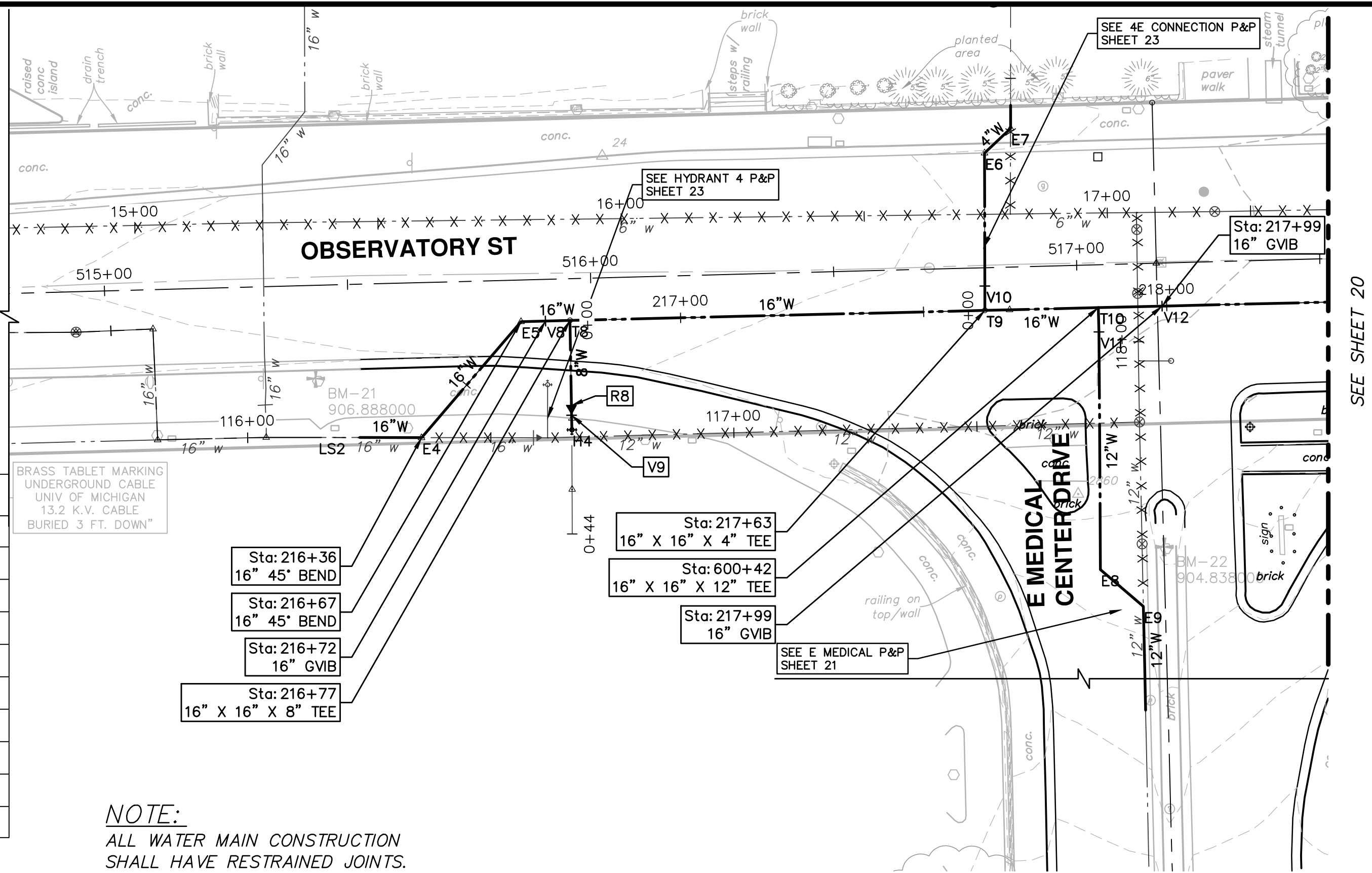

NOTE:
ALL WATER MAIN CONSTRUCTION SHALL HAVE RESTRAINED JOINTS.

PR WATER OBSERVATORY PROJECT

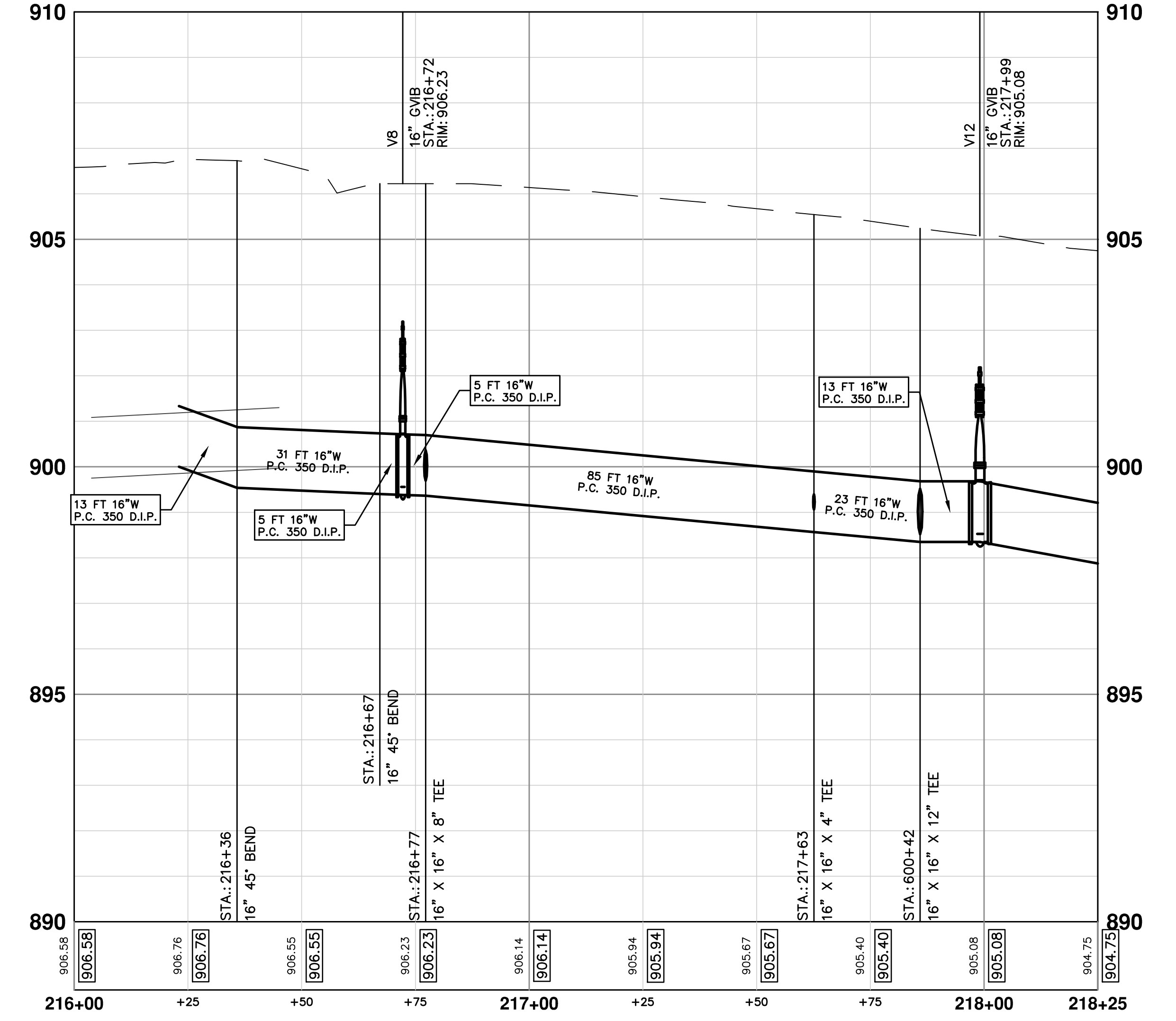
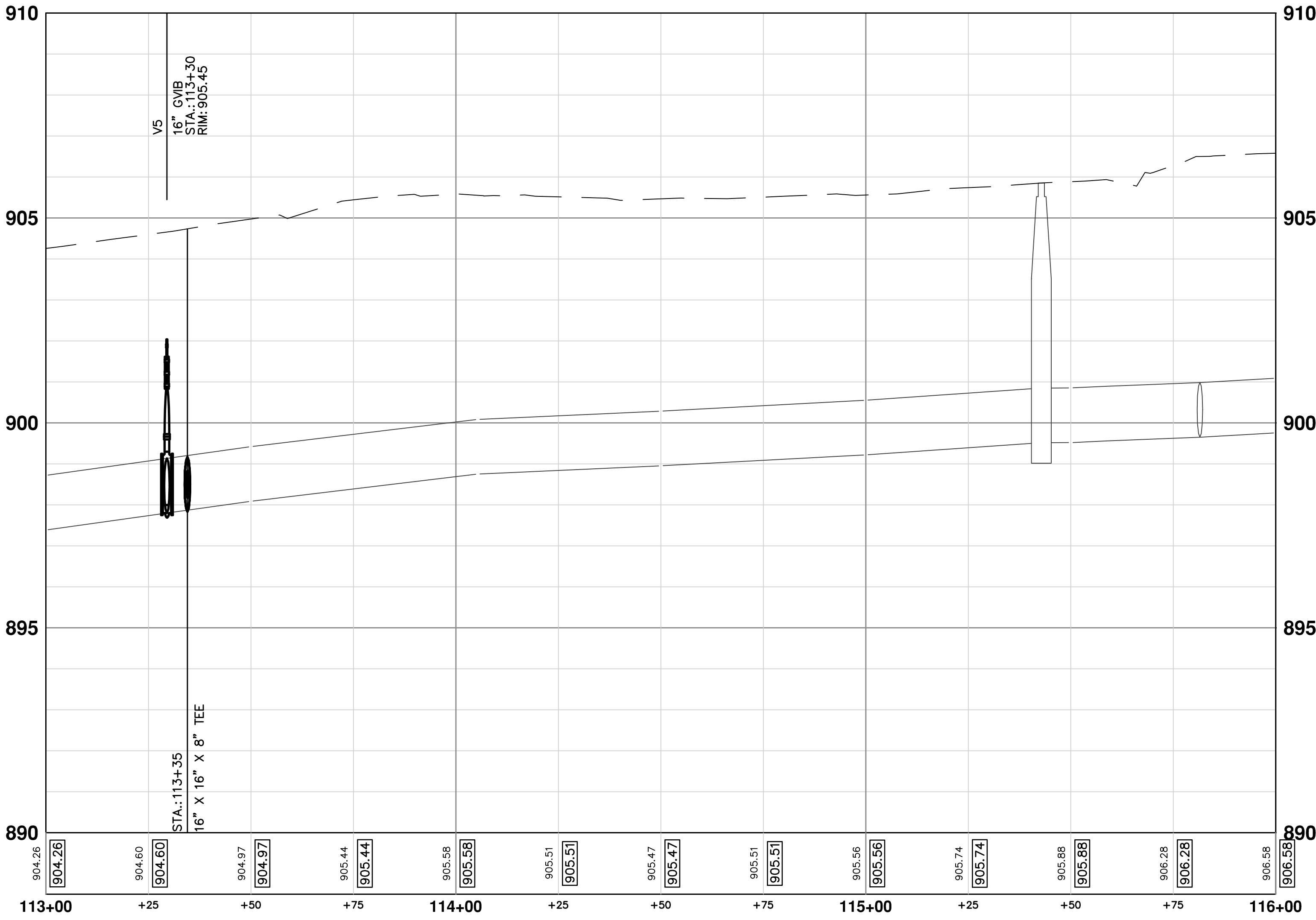

Know what's below.
Call before you dig.

01 U OF M REVIEW 11/05/2015 JKA
00 PROJECT ENGINEER REVIEW 10/02/2015 JKA

DATE DRAWN CHECKED

CITY OF ANN ARBOR
PUBLIC SERVICES
301 EAST HURON STREET
ANN ARBOR, MI 48106-0647
www.a2gov.org

PROJECT MANAGEMENT - PUBLIC SERVICES - CITY OF ANN ARBOR

OBSERVATORY STREET IMPROVEMENT PROJECT

WATER

OBSERVATORY 113+00 TO 118+00

SCALE PLAN: 1" = 20'
PROFILE: 1" = 2'

DRAWING No. **2015025-19**

SHEET No. **19 OF 40**

S:\Project Management\Design\2015025 Observatory\Plan Production\2015025WATR.dwg Dwg Created: 1-Sep-15 - _a2 standard bw.stb - Plot Date: 12-Feb-16

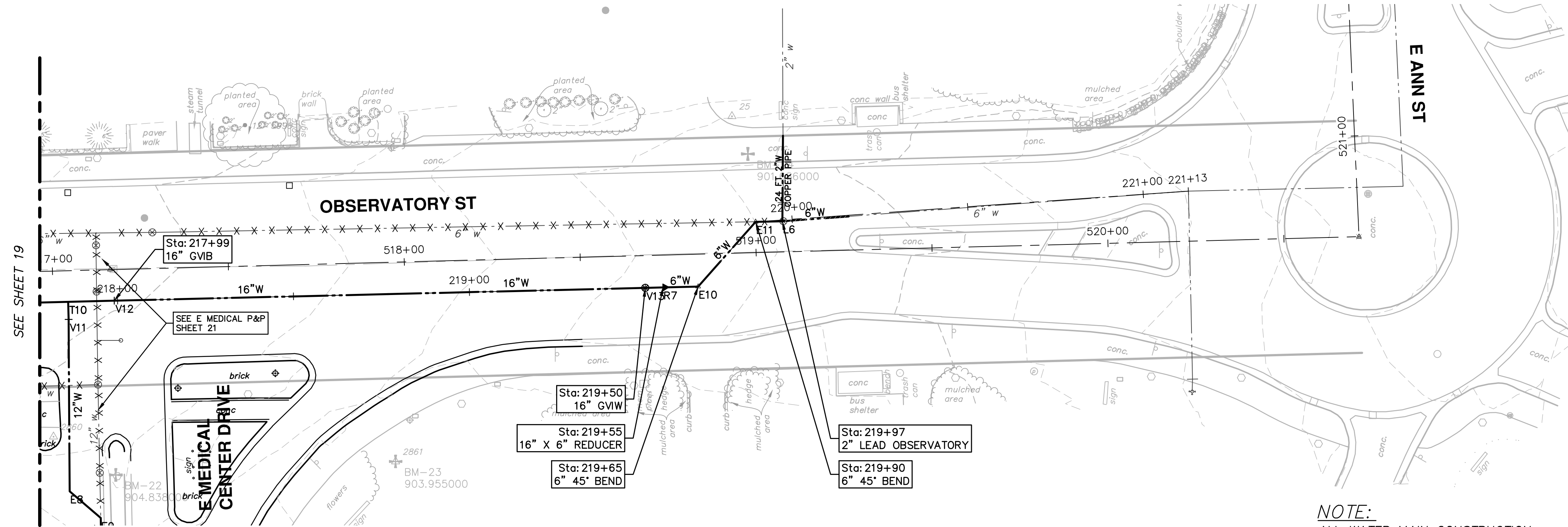

NOTE:
ALL WATER MAIN CONSTRUCTION SHALL HAVE RESTRAINED JOINTS.

PR WATER OBSERVATORY PROJECT

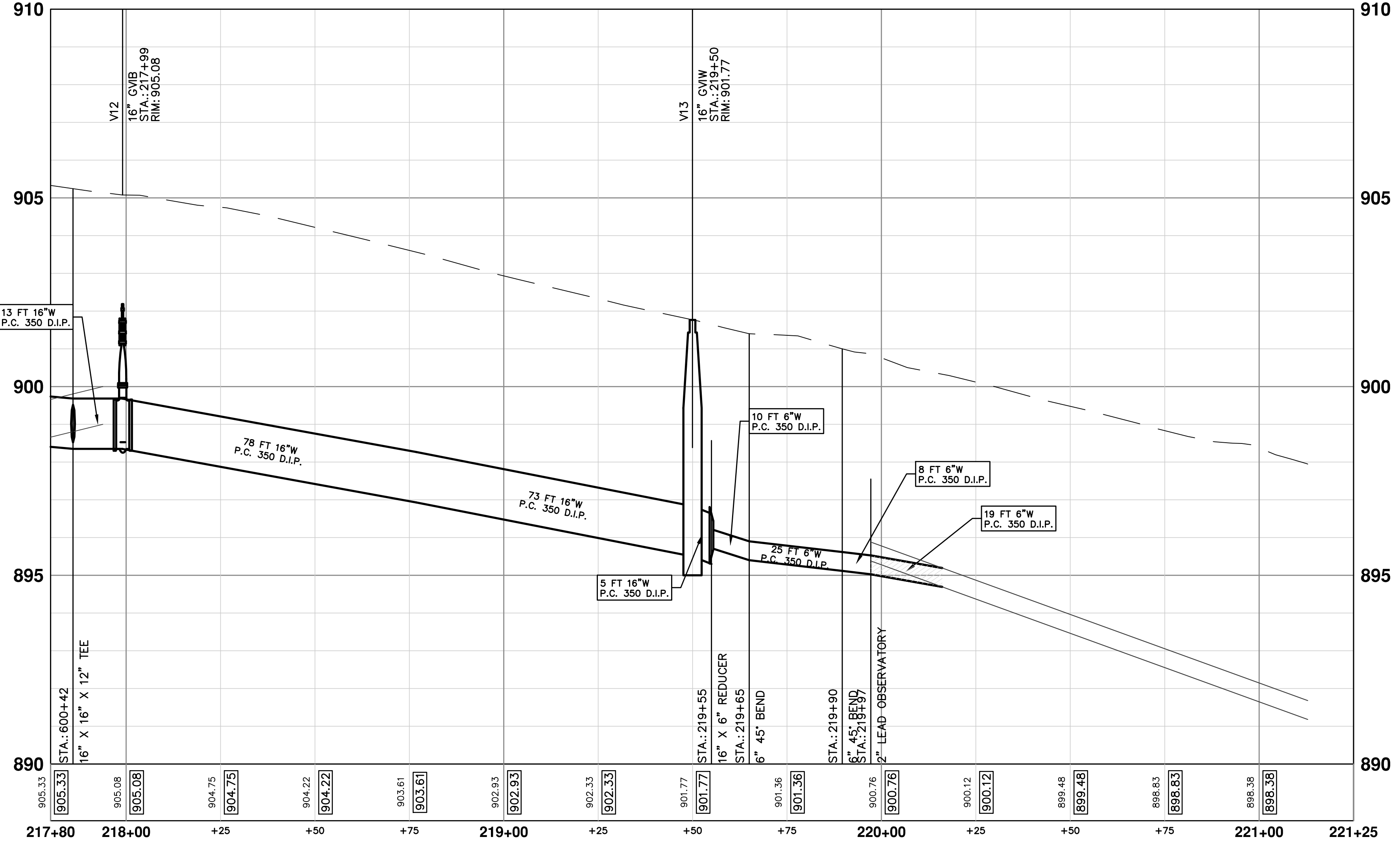

WATER MAIN STRUCTURE TABLE					
STRUCTURE	TYPE	STATION	ALIGNMENT	RIM	DEPTH
V12	16" GMB	217+99	Pr Water Observatory Project	905.08	6.73
V13	16" GWIW	219+50	Pr Water Observatory Project	901.77	6.27
R7	16" X 6" REDUCER	219+55	Pr Water Observatory Project	901.65	6.45
E10	6" 45° BEND	219+65	Pr Water Observatory Project	901.40	6.04
E11	6" 45° BEND	219+90	Pr Water Observatory Project	901.00	5.93
L6	2" LEAD OBSERVATORY	219+97	Pr Water Observatory Project	900.88	6.15
T10	16" X 16" X 12" TEE	600+42	E Medical	905.24	6.89

Know what's below. Call Before you dig.

DATE: 10/02/2015
DRAWN: JKA
CHECKED: JKA
REVIEW: JKA
U OF M REVIEW: 11/05/2015

PROJECT MANAGEMENT - PUBLIC SERVICES - CITY OF ANN ARBOR
OBSERVATORY STREET IMPROVEMENT PROJECT
 WATER
 OBSERVATORY 118+00 TO POE

SCALE PLAN: 1" = 20'
PROFILE: 1" = 2'

DRAWING No. 2015025-20

SHEET No. 20 OF 40

S:\Project Management\Design\2015025 Observatory\Plan Production\2015025WATR.dwg Dwg Created: 1-Sep-15 - _a2 standard bw.stb - Plot Date: 12-Feb-16

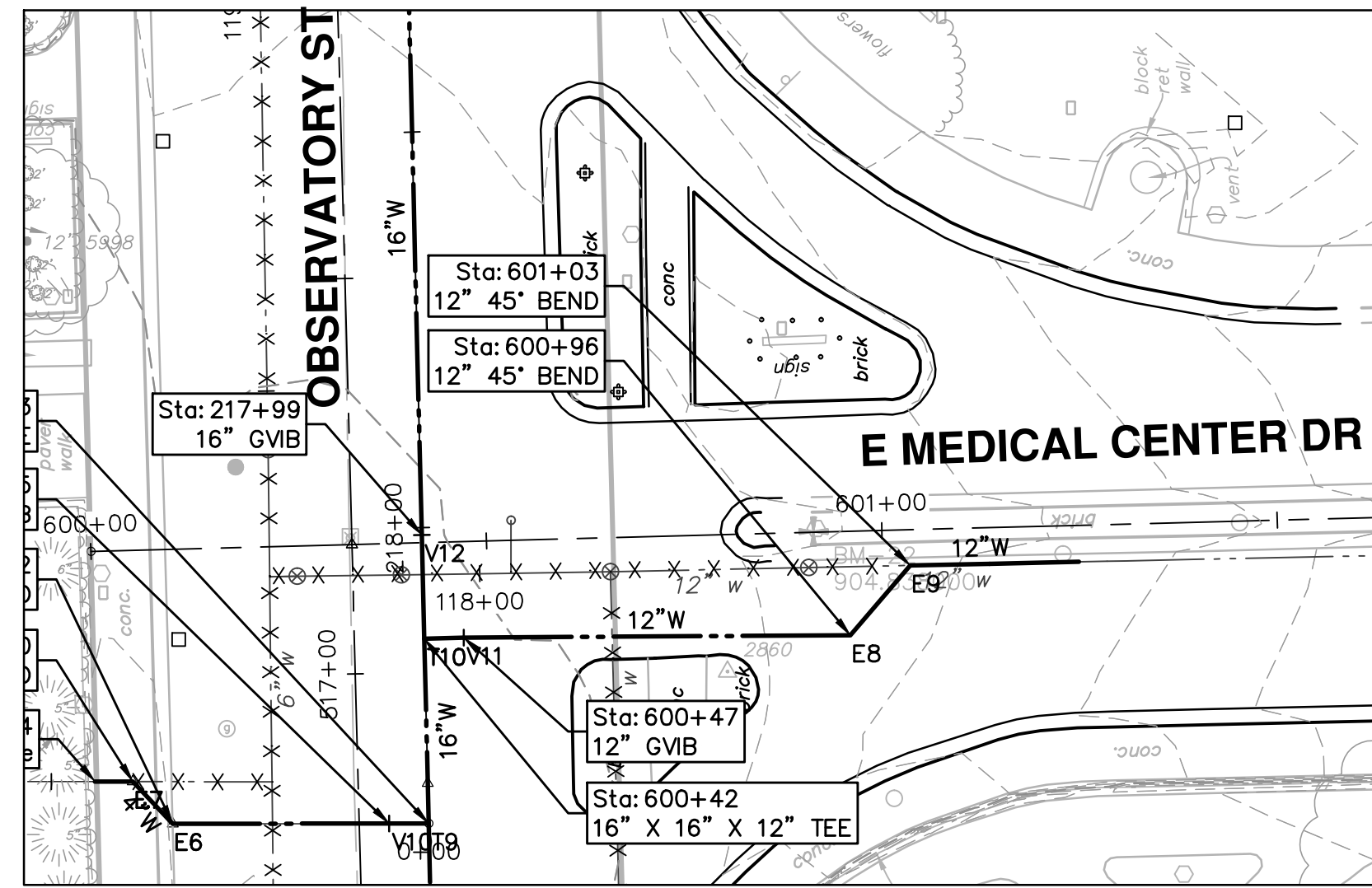
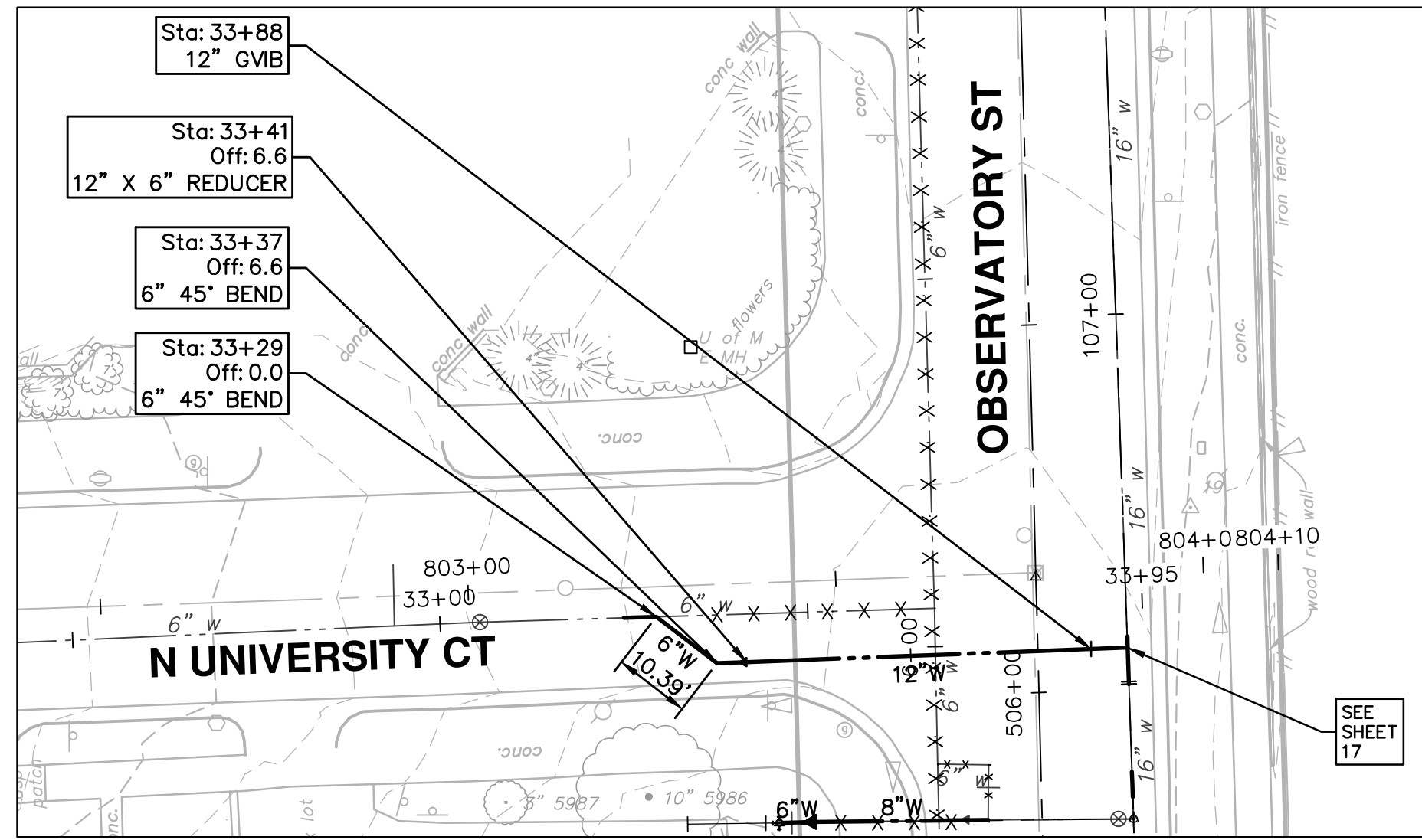

EX WATER N UNIVERSITY CT 6 INCH

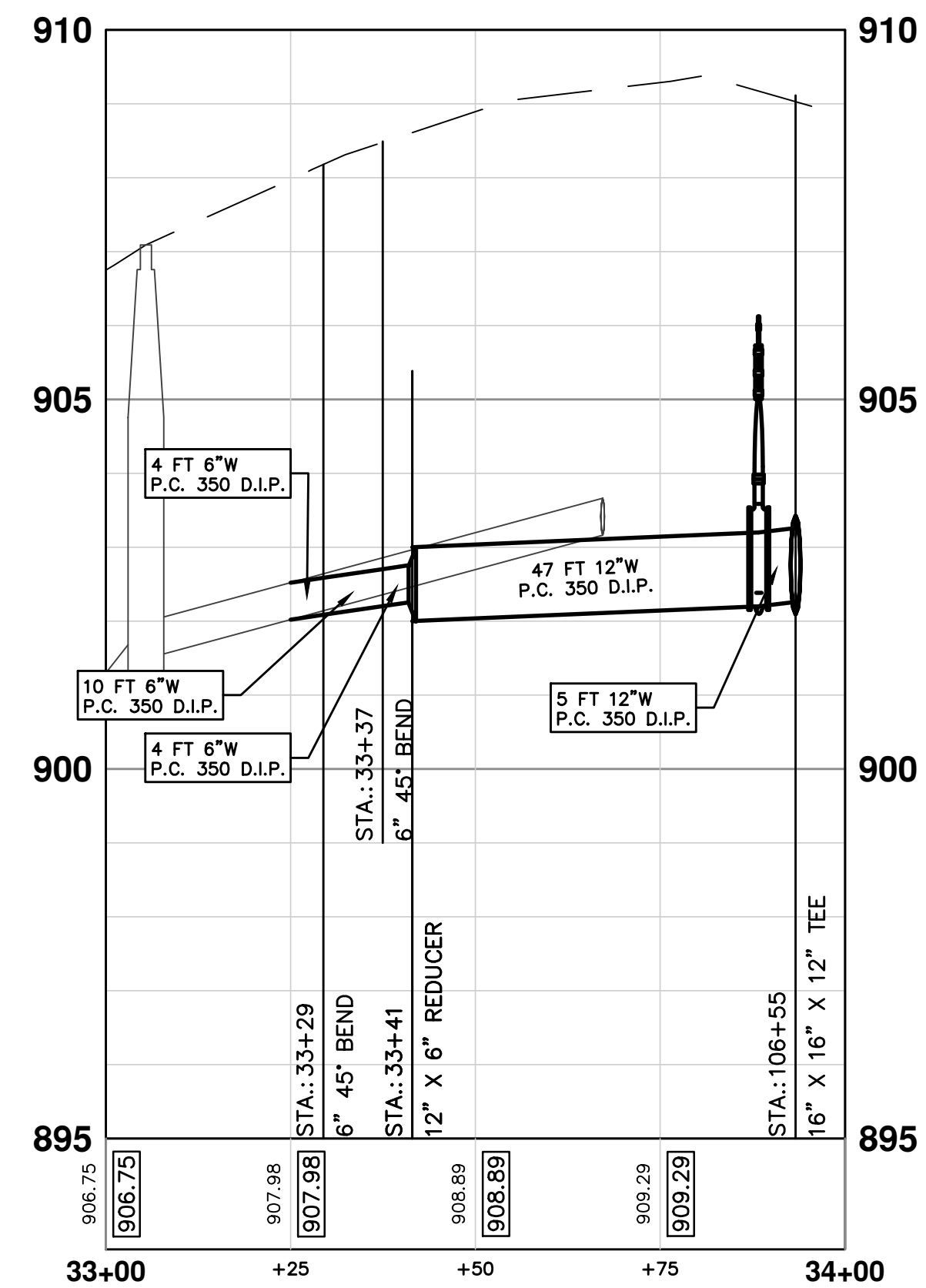

WATER MAIN STRUCTURE TABLE					
STRUCTURE	TYPE	STATION	ALIGNMENT	RIM	DEPTH
E3	6" 45° BEND	33+29	Ex Water N University Ct 6 inch	908.18	6.09
E2	6" 45° BEND	33+37	Ex Water N University Ct 6 inch	908.49	6.29
R2	12" X 6" REDUCER	33+41	Ex Water N University Ct 6 inch	908.65	6.73
V3	12" GVB	33+88	Ex Water N University Ct 6 inch	909.26	7.06
T3	16" X 16" X 12" TEE	106+55	Ex Water Observatory 16 inch	909.11	7.14

NOTE:
ALL WATER MAIN CONSTRUCTION SHALL HAVE RESTRAINED JOINTS.

E MEDICAL

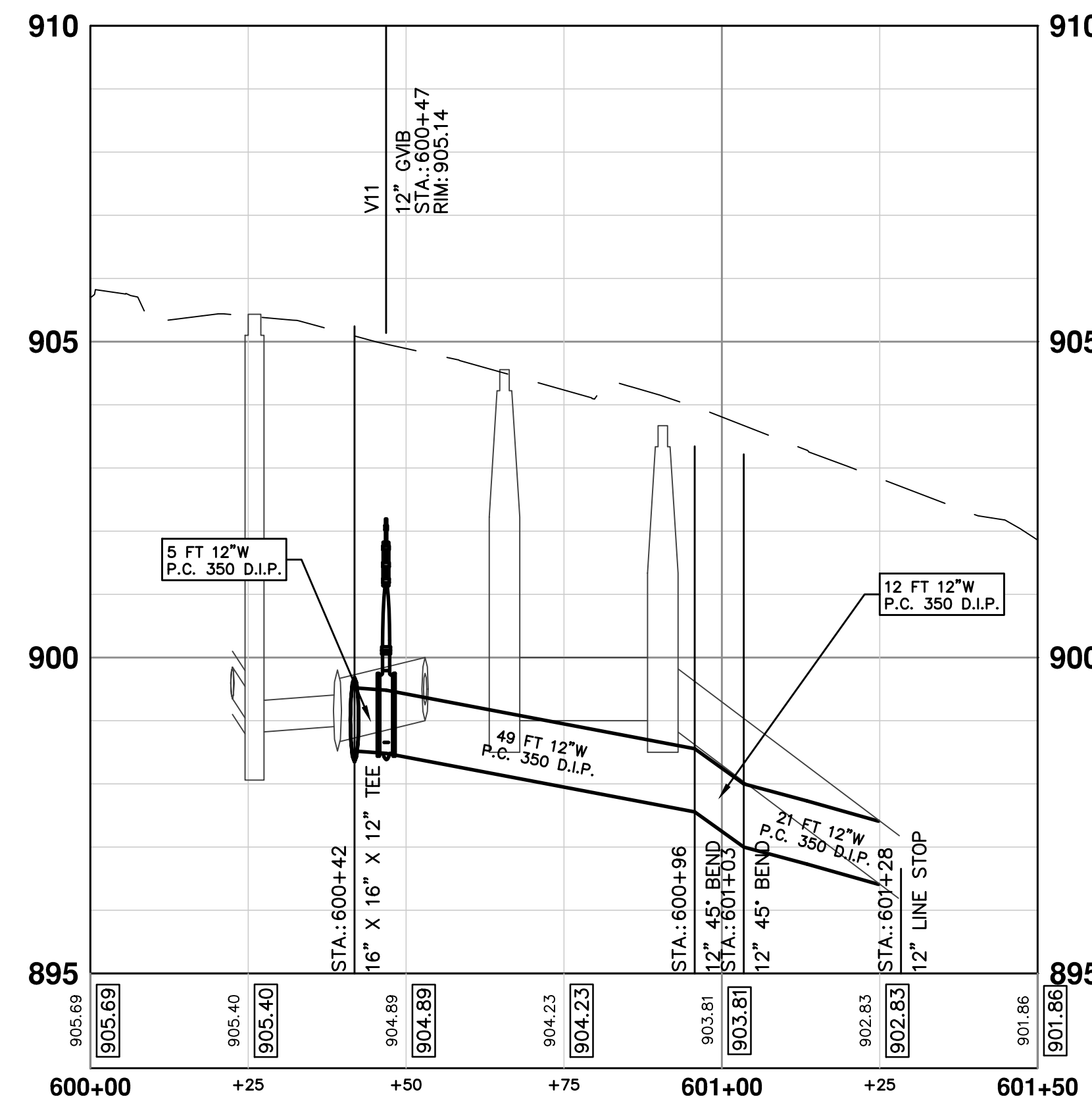

WATER MAIN STRUCTURE TABLE					
STRUCTURE	TYPE	STATION	ALIGNMENT	RIM	DEPTH
T10	16" X 16" X 12" TEE	600+42	E Medical	905.24	6.89
V11	12" GVB	600+47	E Medical	905.14	6.65
E8	12" 45° BEND	600+96	E Medical	903.34	5.78
E9	12" 45° BEND	601+03	E Medical	903.22	6.22
LS-3	12" LINE STOP	601+28	E Medical	897.30	???



REV.	DESCRIPTION	DATE	DRAWN	CHECKED
01	U OF M REVIEW	11/05/2015	JKA	IVK
00	PROJECT ENGINEER REVIEW	10/02/2015	JKA	IVK

CITY OF ANN ARBOR
PUBLIC SERVICE
301 EAST HURON STREET
ANN ARBOR MI 48106-8647
www.a2gov.org

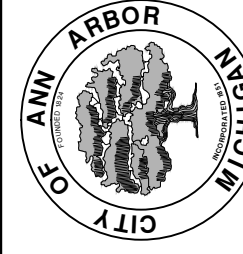

PROJECT MANAGEMENT - PUBLIC SERVICES - CITY OF ANN ARBOR
OBSERVATORY STREET IMPROVEMENT PROJECT
WATER
E MEDICAL, N UNIVERSITY

PROFILE: 1" = 2'
SCALE: PLAN: 1" = 20'
DRAWING No. 2015025-21

S:\Project Management\Design\2015025 Observatory\Plan Production\2015025WATR.dwg Dwg Created: 1-Sep-15 - _a2 standard bw.stb - Plot Date: 12-Feb-16

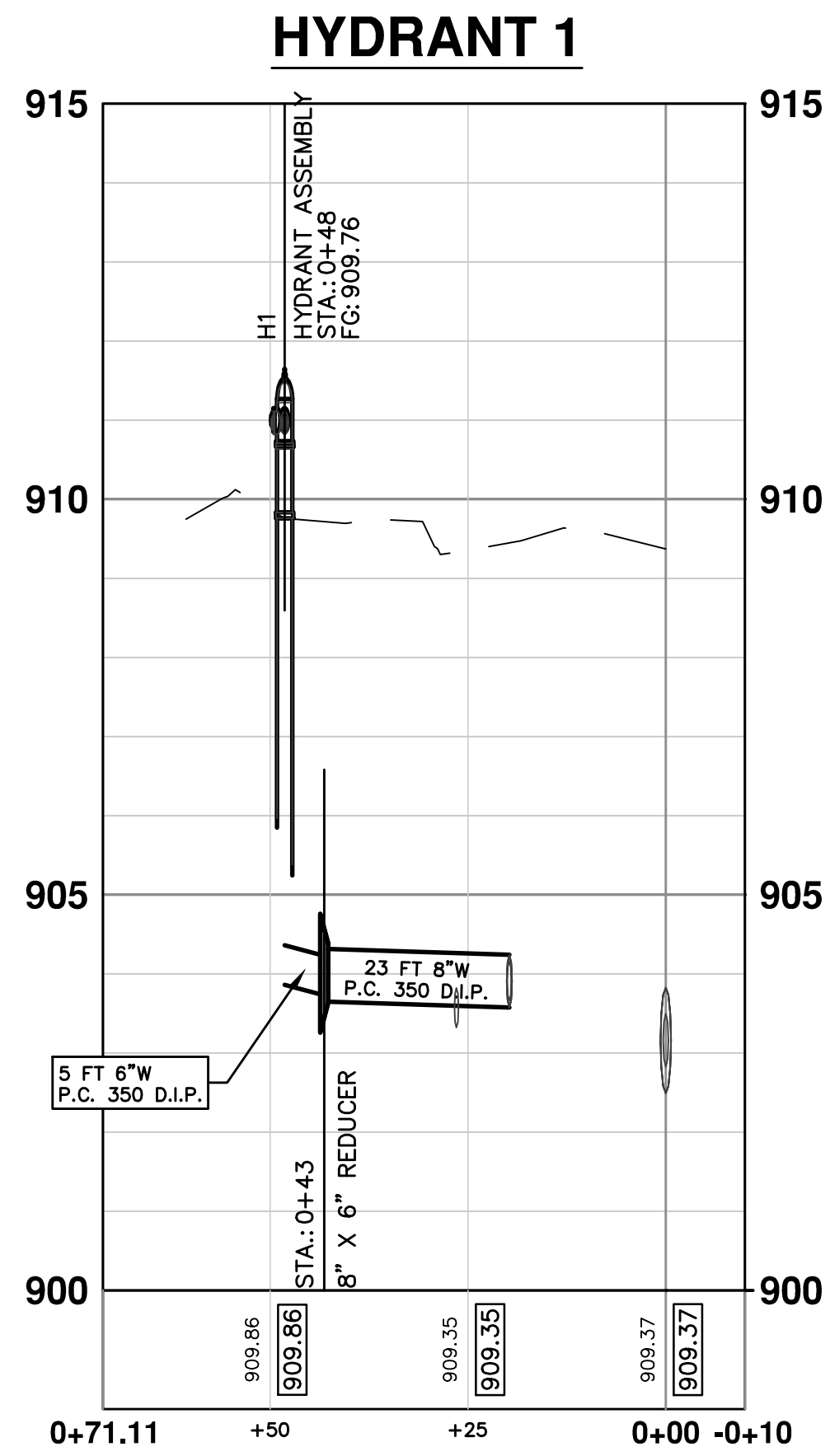
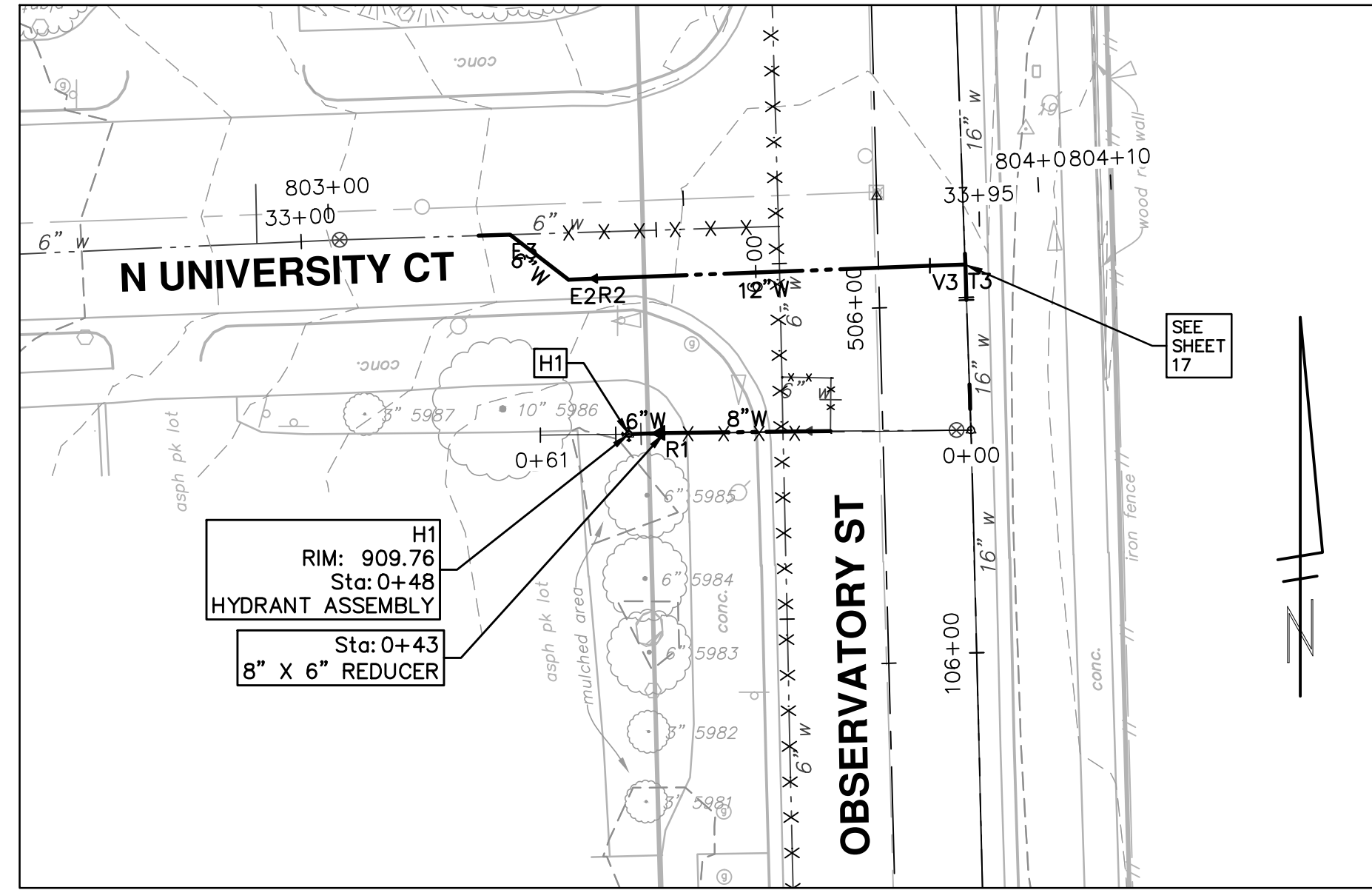

WATER MAIN STRUCTURE TABLE					
STRUCTURE	TYPE	STATION	ALIGNMENT	RIM	DEPTH
R1	8" X 6" REDUCER	0+43	HYDRANT 1	909.71	6.57
H1	HYDRANT ASSEMBLY	0+48	HYDRANT 1	909.76	5.90

NOTE:
ALL WATER MAIN CONSTRUCTION SHALL HAVE RESTRAINED JOINTS.

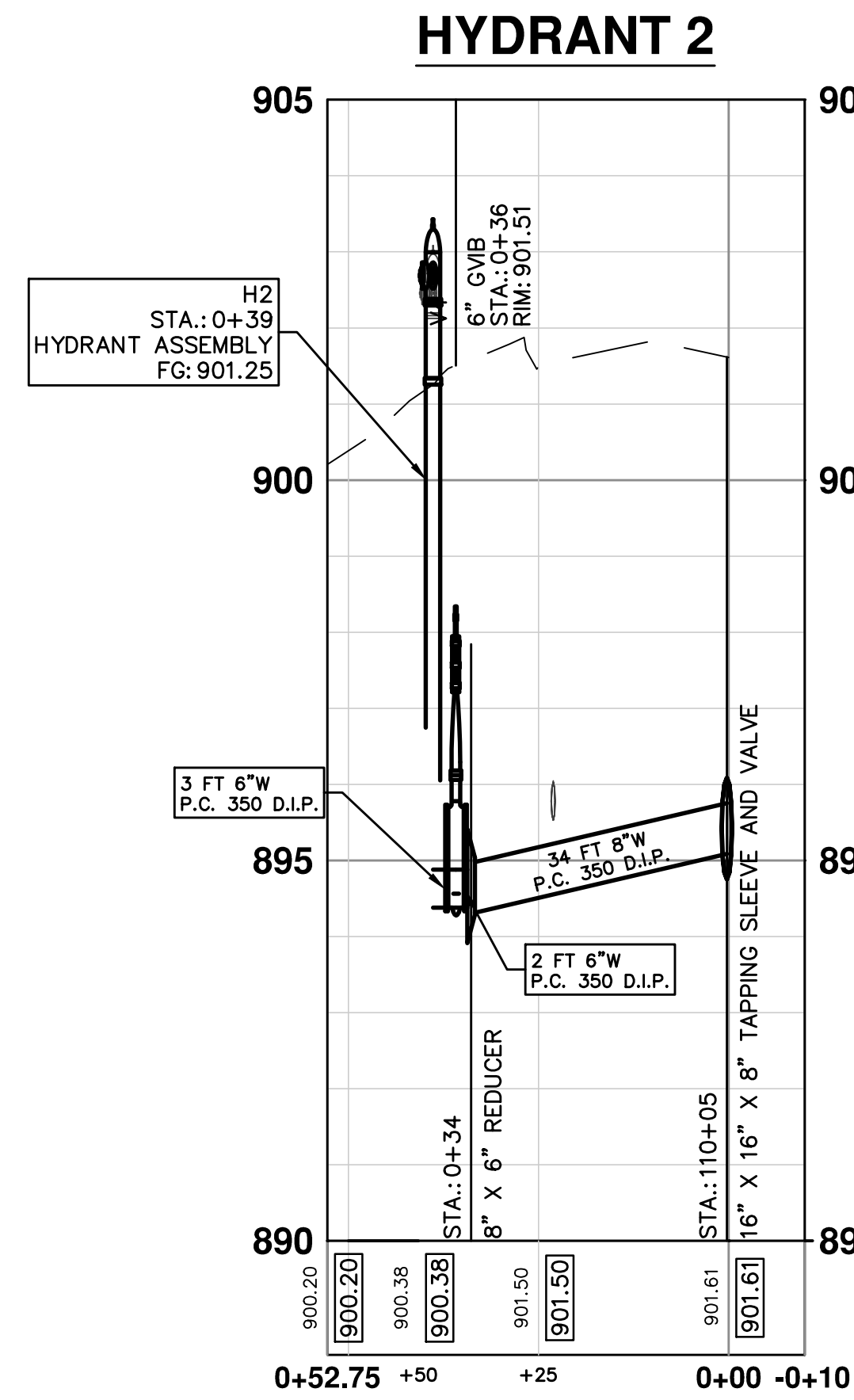
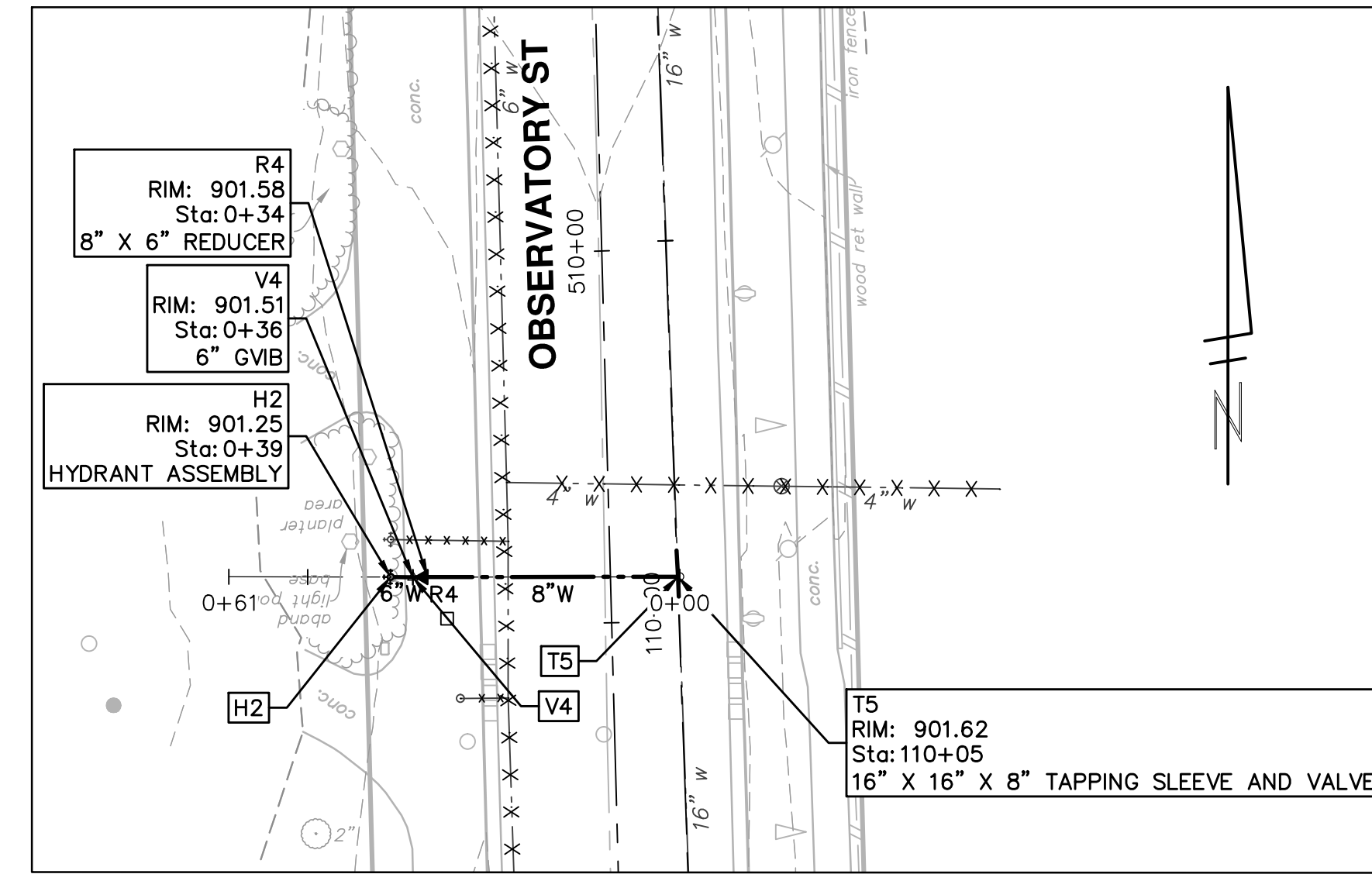

WATER MAIN STRUCTURE TABLE					
STRUCTURE	TYPE	STATION	ALIGNMENT	RIM	DEPTH
R4	8" X 6" REDUCER	0+34	HYDRANT 2	901.58	7.78
V4	6" G.V.I.B.	0+36	HYDRANT 2	901.51	7.13
H2	HYDRANT ASSEMBLY	0+39	HYDRANT 2	901.25	6.87
T5	16" X 16" X 8" TAPPING SLEEVE AND VALVE	110+05	Ex Water Observatory 16 inch	901.62	6.86



Know what's below. Call before you dig.

CITY OF ANN ARBOR
PUBLIC SERVICE
301 EAST HURON STREET
PO BOX 8647
ANN ARBOR MI 48106-8647
www.a2gov.org



PROJECT MANAGEMENT - PUBLIC SERVICES - CITY OF ANN ARBOR
OBSERVATORY STREET IMPROVEMENT PROJECT
WATER
H1, H2

SCALE PLAN: 1" = 20'
PROFILE: 1" = 2'
DRAWING No.
2015025-22

SHEET No.

S:\Project Management\Design\2015025\Observatory\Plan Production\2015025WATR.dwg Dwg Created: 1-Sep-15 - _a2 standard bw.stb - Plot Date: 12-Feb-16

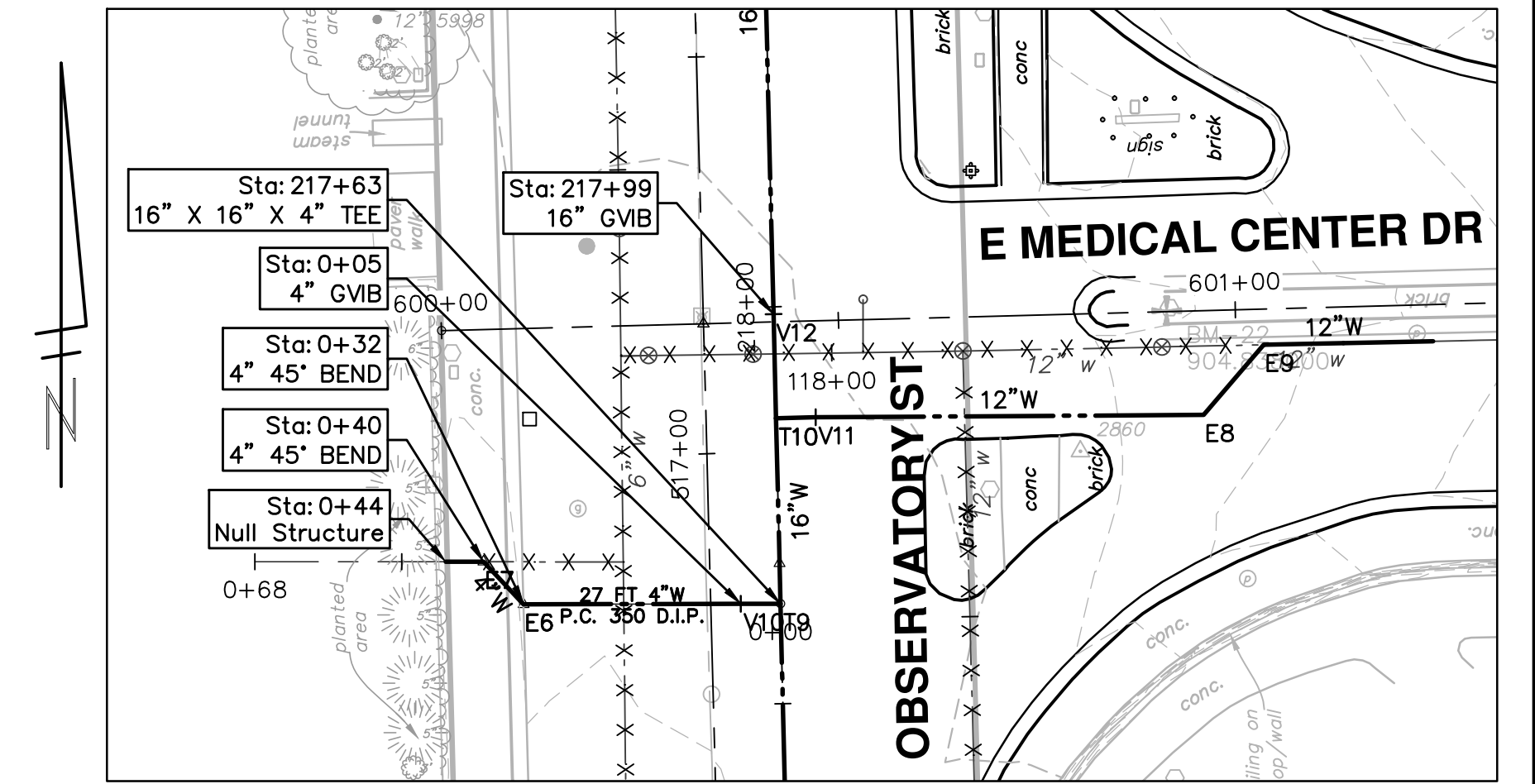
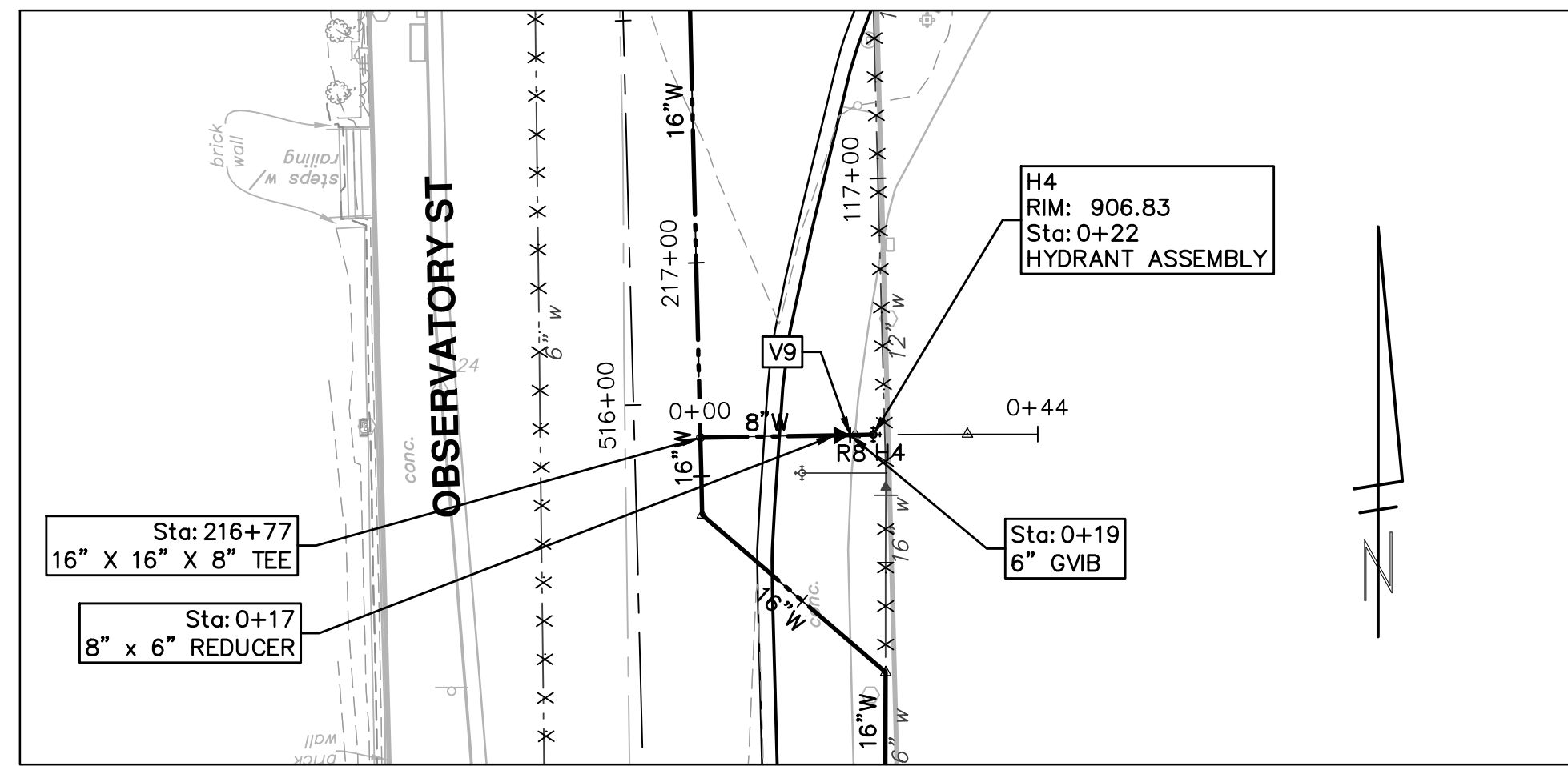
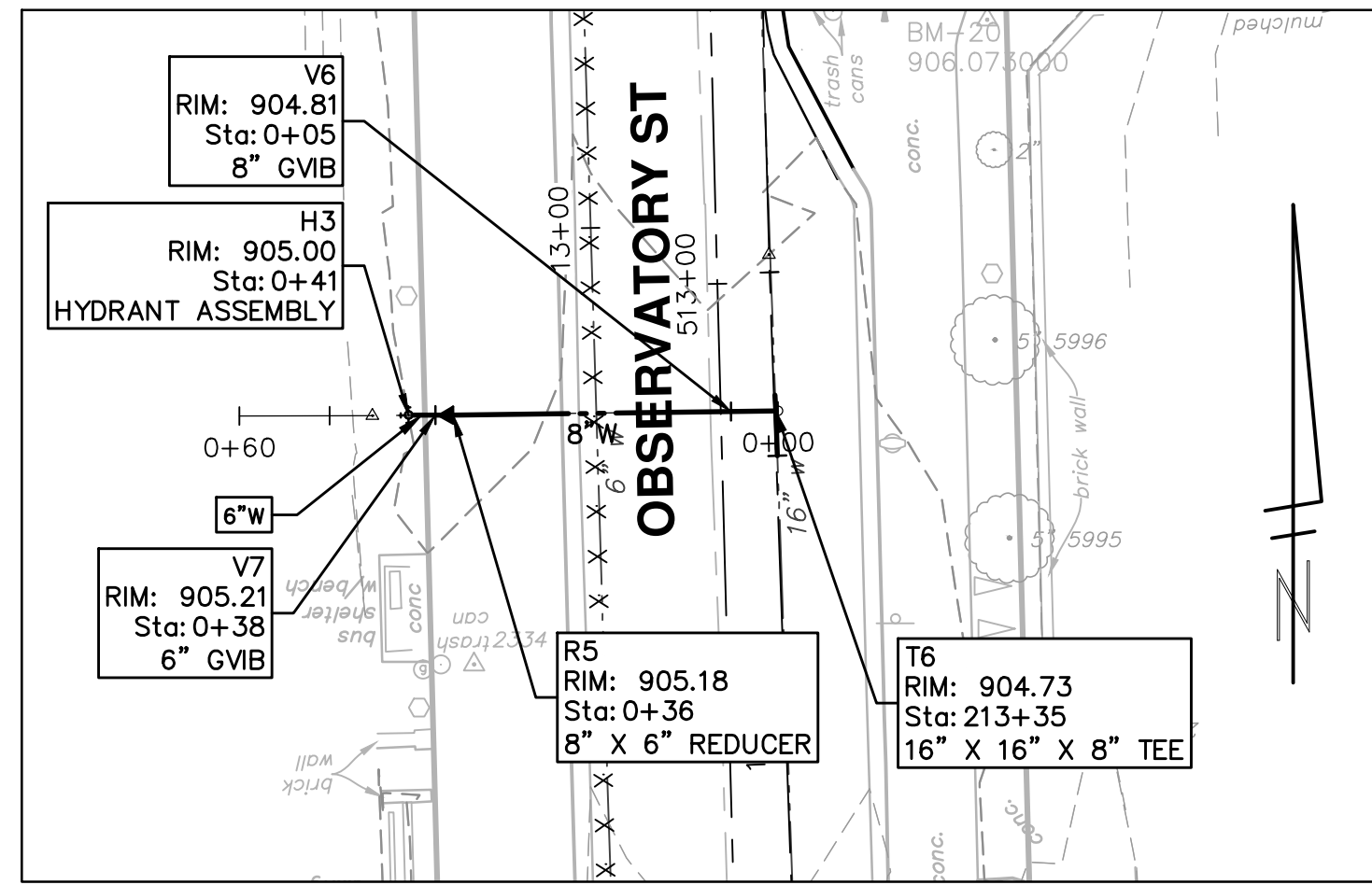

HYDRANT 3

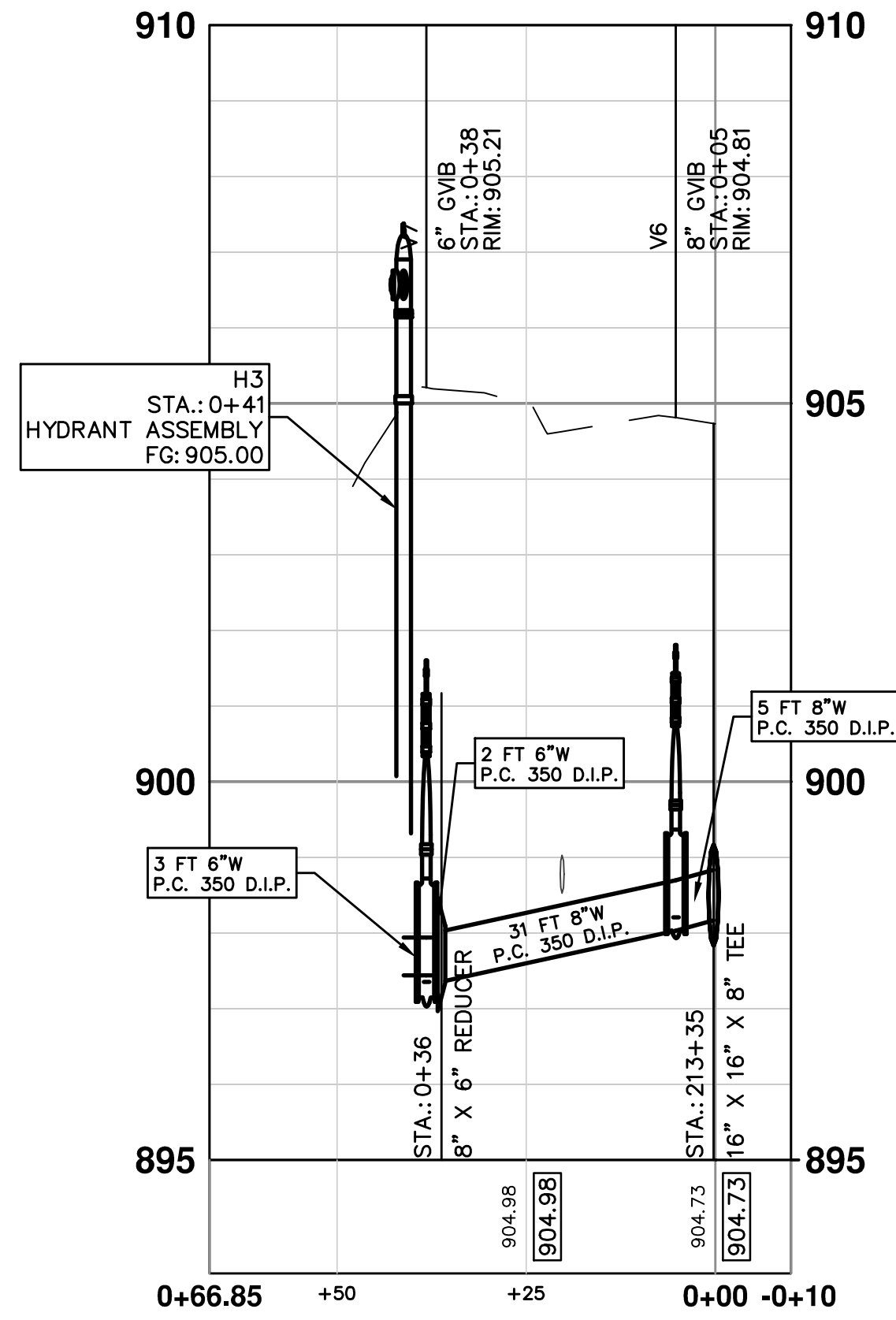

NOTE:
ALL WATER MAIN CONSTRUCTION SHALL HAVE RESTRAINED JOINTS.

HYDRANT 4

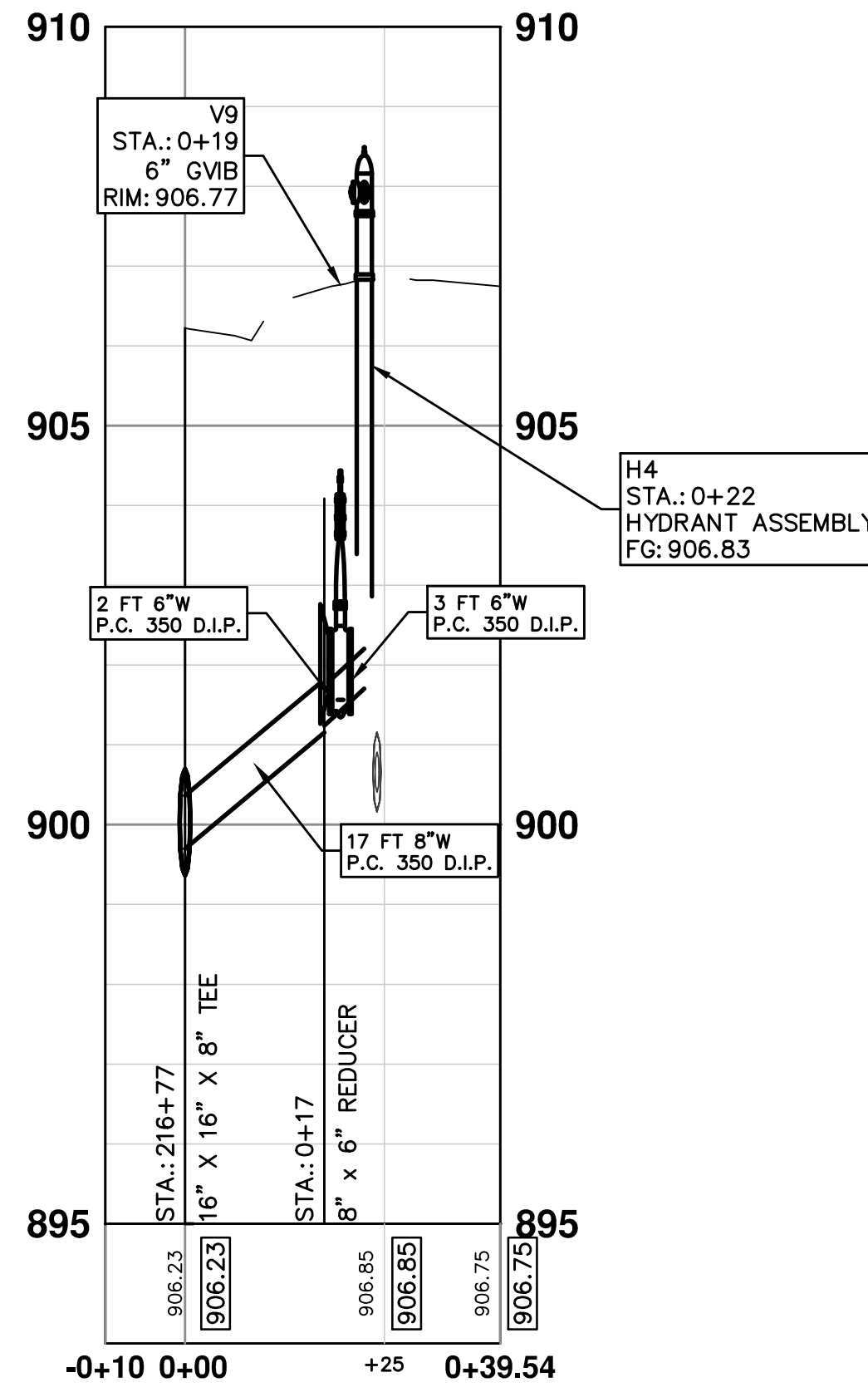

4E

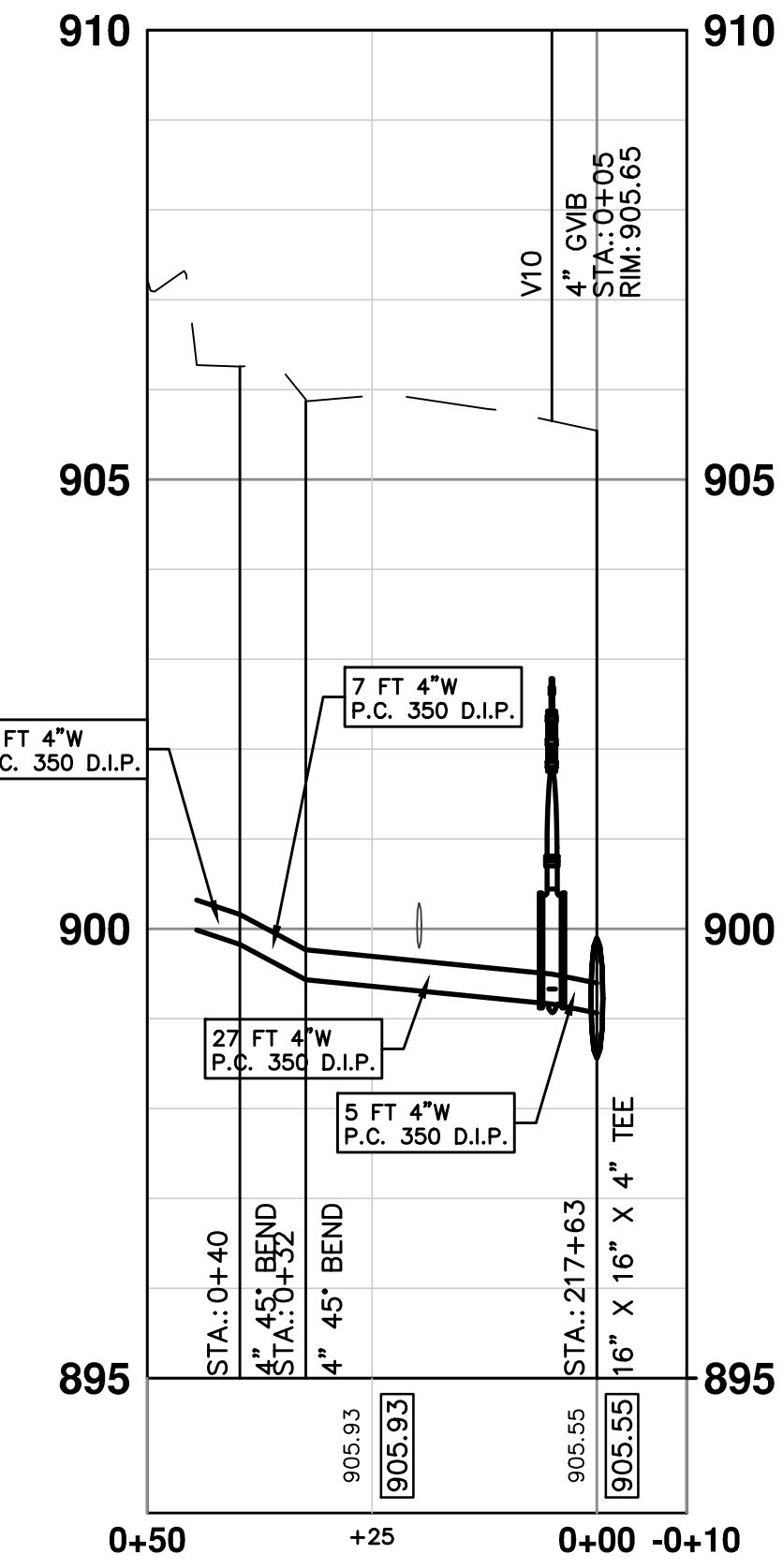

WATER MAIN STRUCTURE TABLE

STRUCTURE	TYPE	STATION	ALIGNMENT	RIM	DEPTH
V6	8" GVB	0+05	HYDRANT 3	904.81	6.78
R5	8" X 6" REDUCER	0+36	HYDRANT 3	905.18	8.33
V7	6" GVB	0+38	HYDRANT 3	905.21	8.06
H3	HYDRANT ASSEMBLY	0+41	HYDRANT 3	905.00	7.56
T6	16" X 16" X 8" TEE	213+35	Pr Water Observatory Project	904.73	7.14

WATER MAIN STRUCTURE TABLE

STRUCTURE	TYPE	STATION	ALIGNMENT	RIM	DEPTH
R8	8" x 6" REDUCER	0+17	HYDRANT 4	906.72	5.57
V9	6" GVB	0+19	HYDRANT 4	906.77	5.34
H4	HYDRANT ASSEMBLY	0+22	HYDRANT 4	906.83	5.13
T8	16" X 16" X 8" TEE	216+77	Pr Water Observatory Project	906.23	6.86

WATER MAIN STRUCTURE TABLE

STRUCTURE	TYPE	STATION	ALIGNMENT	RIM	DEPTH
V10	4" GVB	0+05	4E	905.65	6.49
E6	4" 45° BEND	0+32	4E	905.87	6.44
E7	4" 45° BEND	0+40	4E	906.26	6.43
T9	16" X 16" X 4" TEE	217+63	Pr Water Observatory Project	905.55	7.07



CITY OF ANN ARBOR
PUBLIC SERVICES
301 EAST HURON STREET
ANN ARBOR, MI 48106-1667
www.a2gov.org

PROJECT MANAGEMENT - PUBLIC SERVICES - CITY OF ANN ARBOR
OBSERVATORY STREET IMPROVEMENT PROJECT
WATER
H3, H4, 4E

SCALE PLAN: 1" = 20'
PROFILE: 1" = 2'
DRAWING No. 2015025-23
SHEET No. 23 OF 40

REV.	DATE	DESCRIPTION
01	11/05/2015	U OF M REVIEW
00	10/02/2015	PROJECT ENGINEER REVIEW

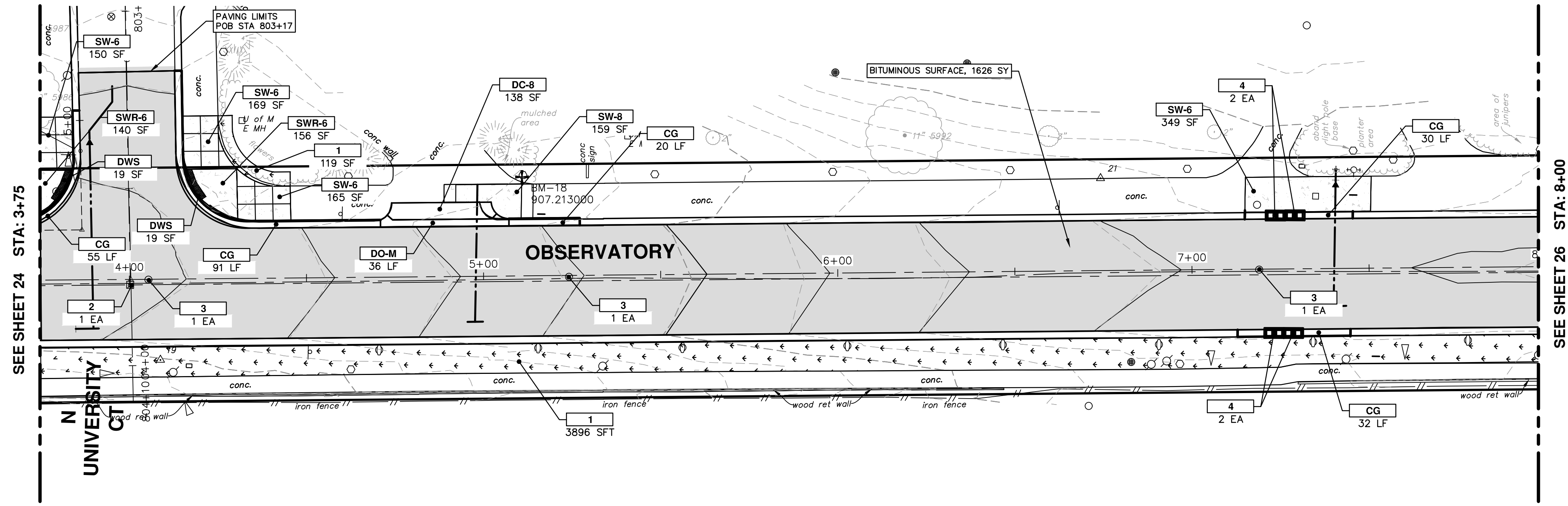

OBSERVATORY CROWN - (1)

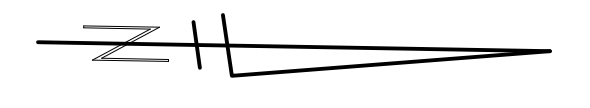
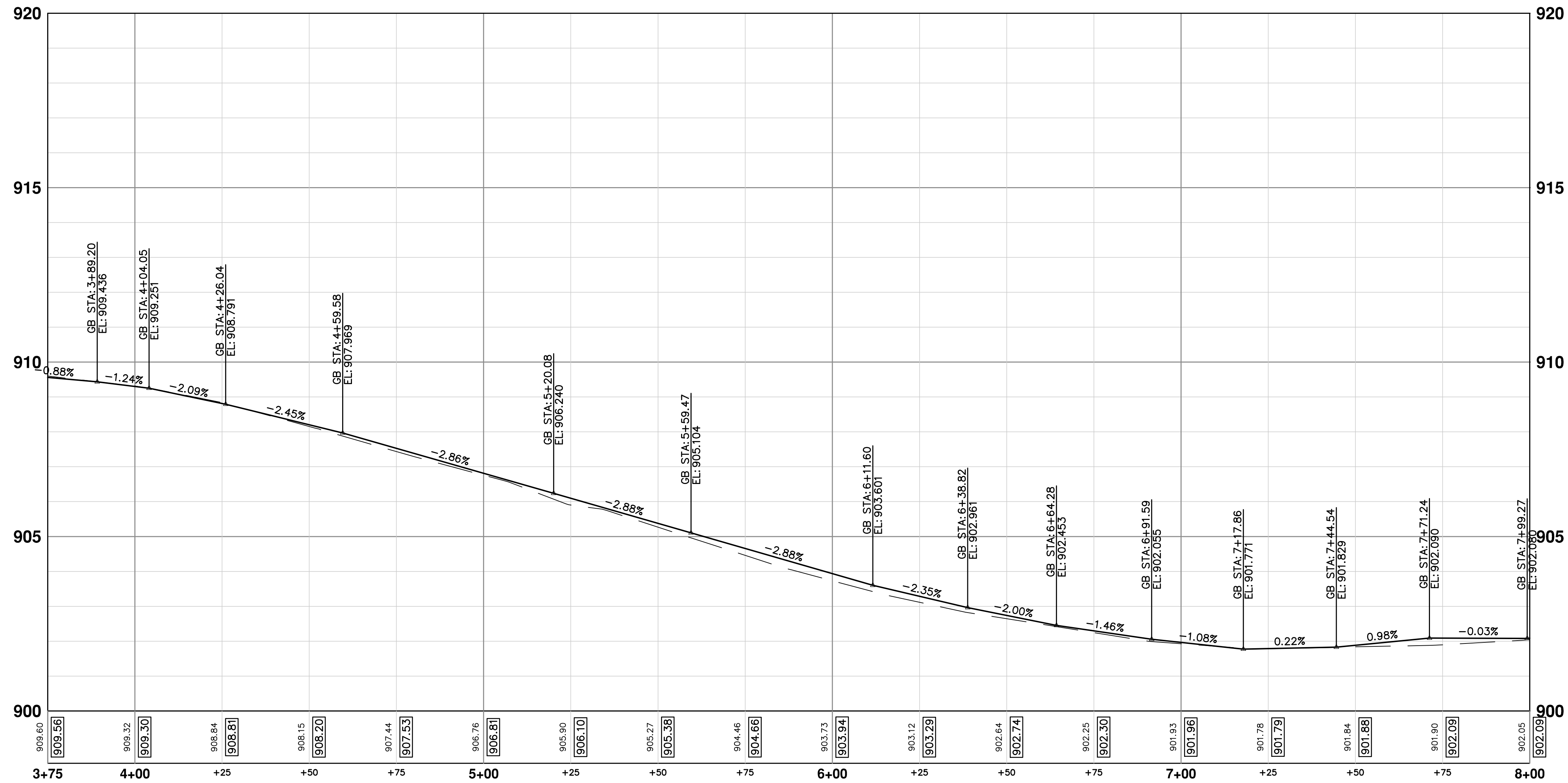

CONSTRUCTION KEY	
KEY	DESCRIPTION
HMA	SURFACE AREA FOR HMA
CG	CURB AND GUTTER, CONC. BARRIER
DO-M	DRIVEWAY OPENING, CONC. TYPE M
DC-8	DRIVE APPROACH, NON-REINF CONC, 8 INCH
SW-4	SIDEWALK, CONC, 4 INCH
SW-6	SIDEWALK, CONC, 6 INCH
SW-8	SIDEWALK, CONC, 8 INCH
SWR-6	SIDEWALK RAMP, CONC, 6 INCH
DWS	DETECTABLE WARNING SURFACE
ABO	ADJUST BY OTHERS
HH	HAND HOLE
MA-F	MAST ARM FOUNDATION
PS-F	PEDESTRIAN SIGNAL FOUNDATION
1	SLOPE RESTORATION*
2	ADJUST GATE VALVE BOX, MONUMENT BOX, OR GAS BOX.
3	ADJUST STRUCTURE COVER
4	DR STRUCTURE, 24 INCH DIA & DR STRUCTURE COVER, TYPE K
5	DOUBLE DR STRUCTURE & DR STRUCTURE COVERS, TYPE K

* THIS ITEM INCLUDES TOPSOIL SURFACE, FURN, 4 INCH; FERTILIZER CHEMICAL NUTRIENT CL A; SEEDING TUF COMPLETE; AND MULCH BLANKET.

Know what's below. Call before you dig.

DATE: 2/09/2016
 U OF M REVIEW: 11/05/2015
 PROJECT ENGINEER REVIEW: 10/02/2015

REV. 02 BID SET
 01 U OF M REVIEW
 00 PROJECT ENGINEER REVIEW

CITY OF ANN ARBOR
 PUBLIC SERVICES
 301 EAST HURON STREET
 ANN ARBOR, MI 48106-0667
 www.a2gov.org

PROJECT MANAGEMENT - PUBLIC SERVICES - CITY OF ANN ARBOR
OBSERVATORY STREET IMPROVEMENT PROJECT
 ROAD
 OBSERVATORY 3+75 TO 8+00

SHEET No. 25 OF 40

SCALE PLAN: 1" = 20'
 PROFILE: 1" = 2'

DRAWING No. 2015025-25

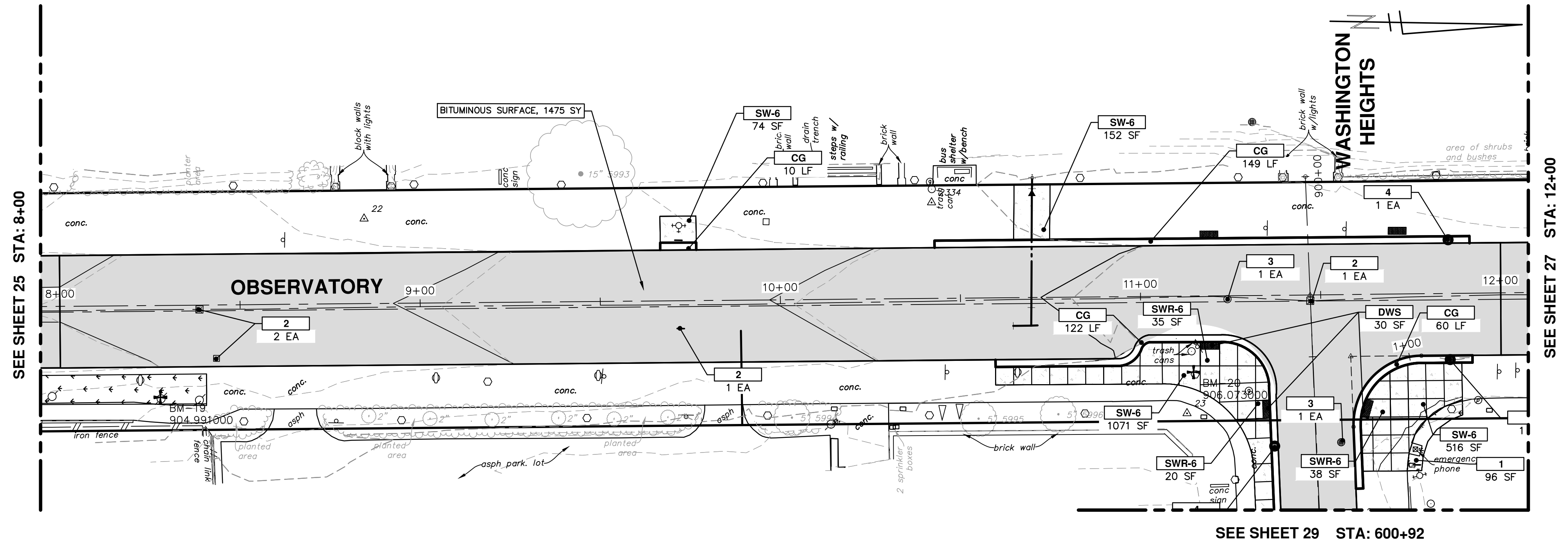

OBSERVATORY CROWN - (1)

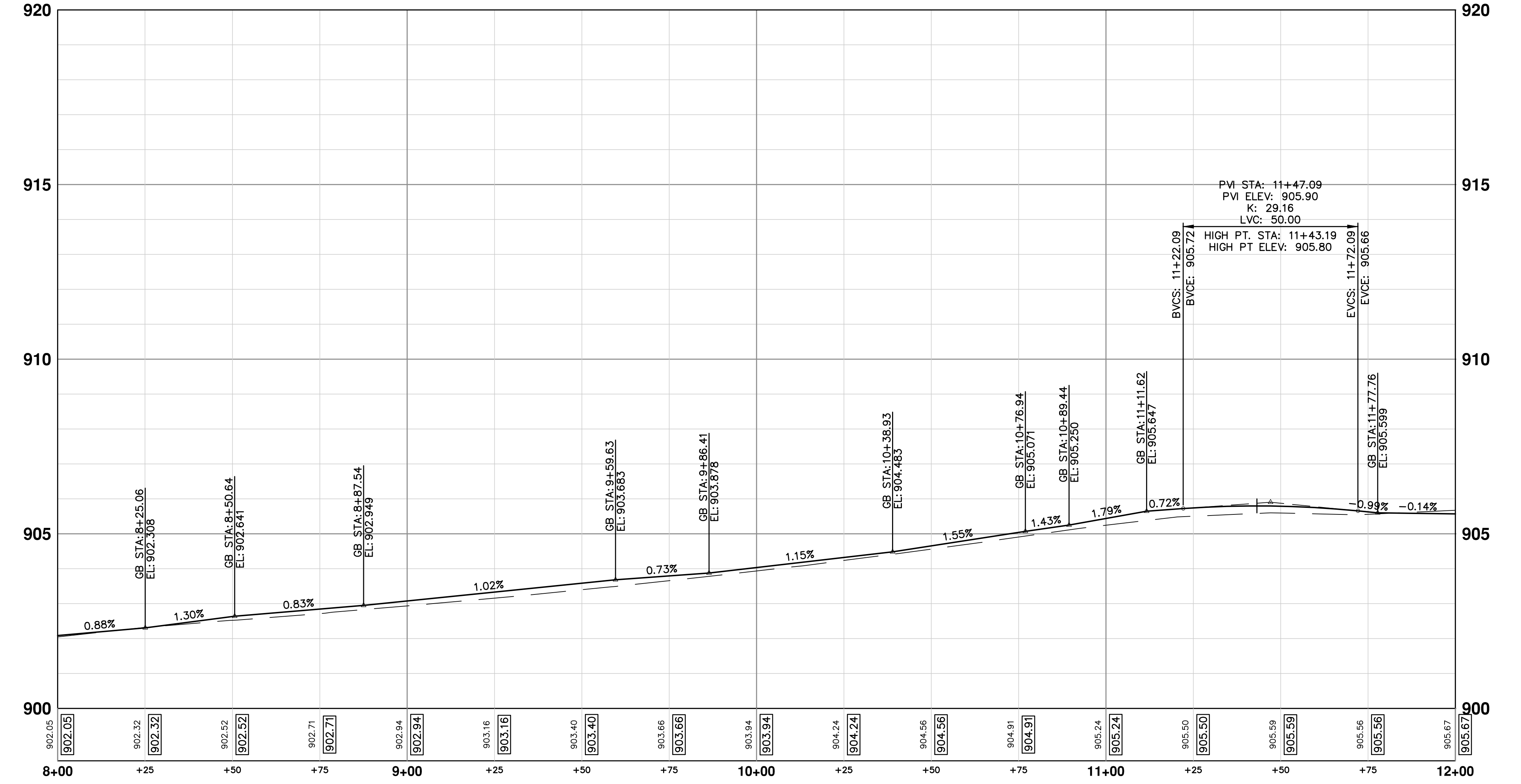

CONSTRUCTION KEY	
KEY	DESCRIPTION
HMA	SURFACE AREA FOR HMA
CG	CURB AND GUTTER, CONC. BARRIER
DO-M	DRIVEWAY OPENING, CONC. TYPE M
DC-8	DRIVE APPROACH, NON-REINF CONC. 8 INCH
SW-4	SIDEWALK, CONC. 4 INCH
SW-6	SIDEWALK, CONC. 6 INCH
SW-8	SIDEWALK, CONC. 8 INCH
SWR-6	SIDEWALK RAMP, CONC. 6 INCH
DWS	DETECTABLE WARNING SURFACE
ABO	ADJUST BY OTHERS
HH	HAND HOLE
MA-F	MAST ARM FOUNDATION
PS-F	PEDESTRIAN SIGNAL FOUNDATION
1	SLOPE RESTORATION*
2	ADJUST GATE VALVE BOX, MONUMENT BOX, OR GAS BOX.
3	ADJUST STRUCTURE COVER
4	DR STRUCTURE, 24 INCH DIA & DR STRUCTURE COVER, TYPE K
5	DOUBLE DR STRUCTURE & DR STRUCTURE COVERS, TYPE K

* THIS ITEM INCLUDES TOPSOIL SURFACE, FURN, 4 INCH; FERTILIZER CHEMICAL NUTRIENT CL A; SEEDING TUF COMPLETE; AND MULCH BLANKET.

Know what's below. Call Before you dig.

CITY OF ANN ARBOR PUBLIC SERVICES
301 EAST HURON STREET
ANN ARBOR, MI 48106-1667
www.a2gov.org

PROJECT MANAGEMENT - PUBLIC SERVICES - CITY OF ANN ARBOR
OBSERVATORY STREET IMPROVEMENT PROJECT
ROAD
OBSERVATORY 8+00 TO 12+00

SHEET No. **26 OF 40**

SCALE PLAN: 1" = 20'
PROFILE: 1" = 2'

DRAWING No. **2015025-26**

DATE: 2/09/2016
BY: JKA

DATE: 11/05/2015
BY: JKA

DATE: 10/02/2015
BY: JKA

REV. DESCRIPTION

02 BID SET

01 U OF M REVIEW

00 PROJECT ENGINEER REVIEW

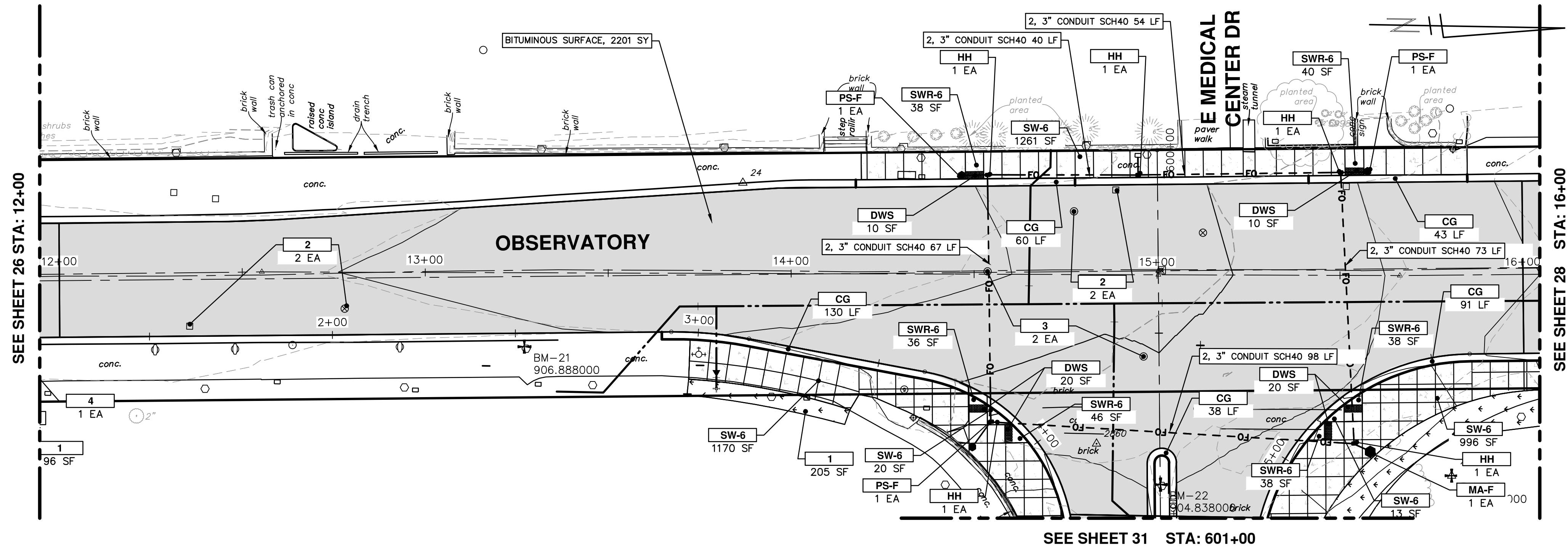

OBSERVATORY CROWN - (1)

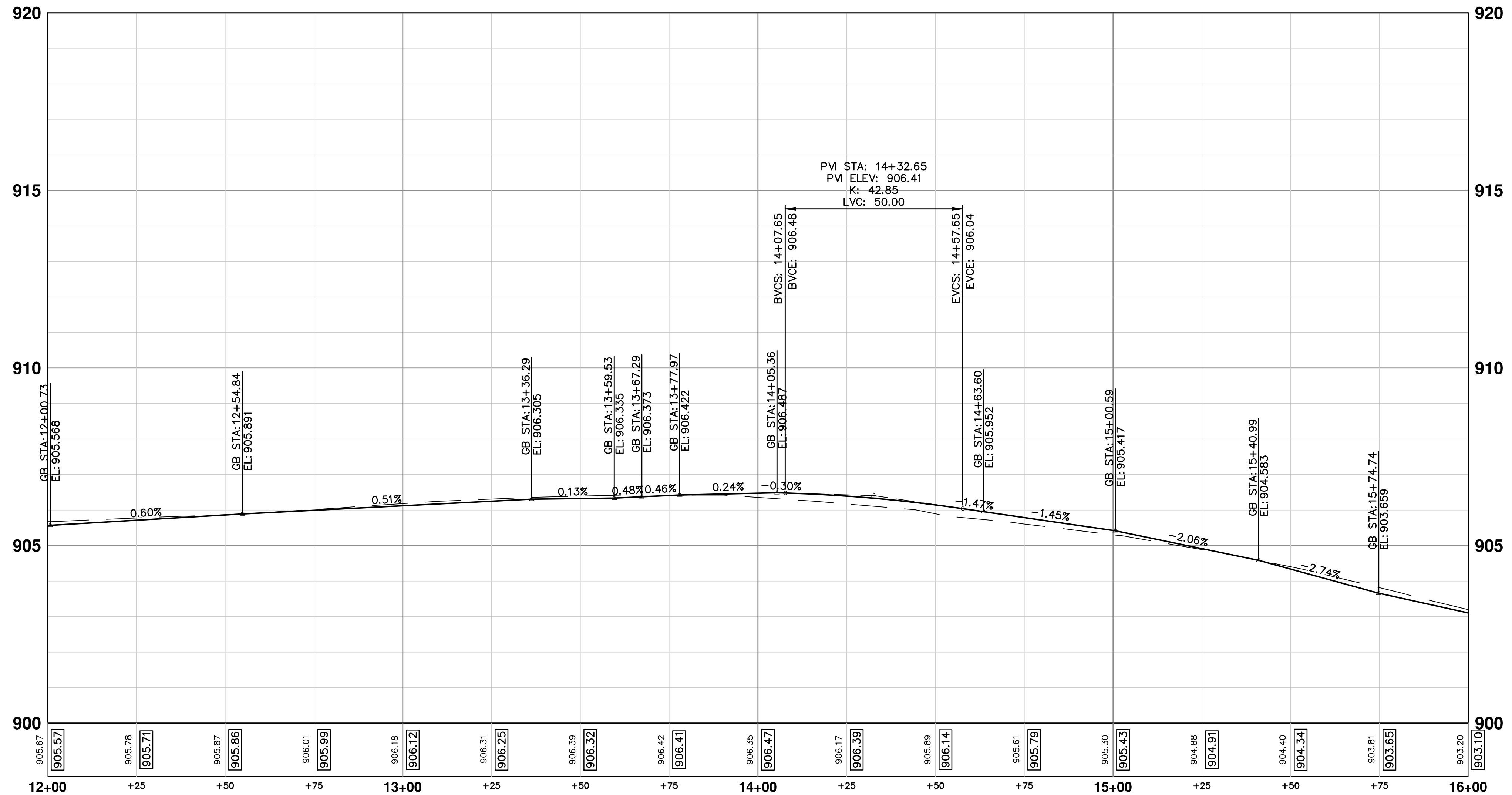

CONSTRUCTION KEY	
KEY	DESCRIPTION
HMA	SURFACE AREA FOR HMA
CG	CURB AND GUTTER, CONC. BARRIER
DO-M	DRIVEWAY OPENING, CONC. TYPE M
DC-8	DRIVE APPROACH, NON-REINF CONC. 8 INCH
SW-4	SIDEWALK, CONC. 4 INCH
SW-6	SIDEWALK, CONC. 6 INCH
SW-8	SIDEWALK, CONC. 8 INCH
SWR-6	SIDEWALK RAMP, CONC. 6 INCH
DWS	DETECTABLE WARNING SURFACE
ABO	ADJUST BY OTHERS
HH	HAND HOLE
MA-F	MAST ARM FOUNDATION
PS-F	PEDESTRIAN SIGNAL FOUNDATION
1	SLOPE RESTORATION*
2	ADJUST GATE VALVE BOX, MONUMENT BOX, OR GAS BOX.
3	ADJUST STRUCTURE COVER
4	DR STRUCTURE, 24 INCH DIA & DR STRUCTURE COVER, TYPE K
5	DOUBLE DR STRUCTURE & DR STRUCTURE COVERS, TYPE K

* THIS ITEM INCLUDES TOPSOIL SURFACE, FURN, 4 INCH; FERTILIZER CHEMICAL NUTRIENT CL A; SEEDING TUF COMPLETE; AND MULCH BLANKET.



CITY OF ANN ARBOR PUBLIC SERVICES
 301 EAST HURON STREET
 P.O. BOX 8647
 ANN ARBOR MI 48106-8647
 www.a2gov.org

PROJECT MANAGEMENT - PUBLIC SERVICES - CITY OF ANN ARBOR
OBSERVATORY STREET IMPROVEMENT PROJECT
 ROAD
 OBSERVATORY 12+00 TO 16+00

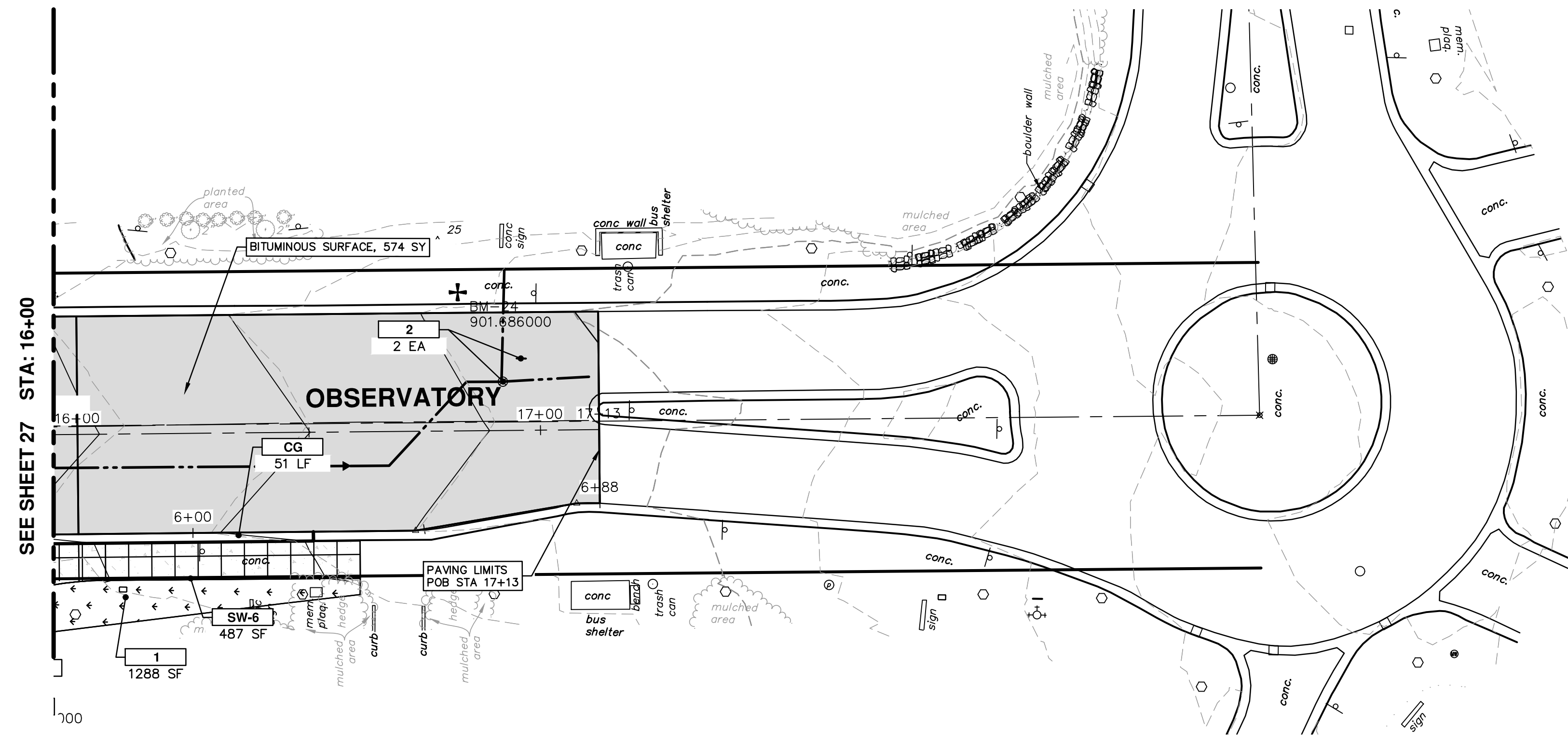

OBSERVATORY CROWN - (1)

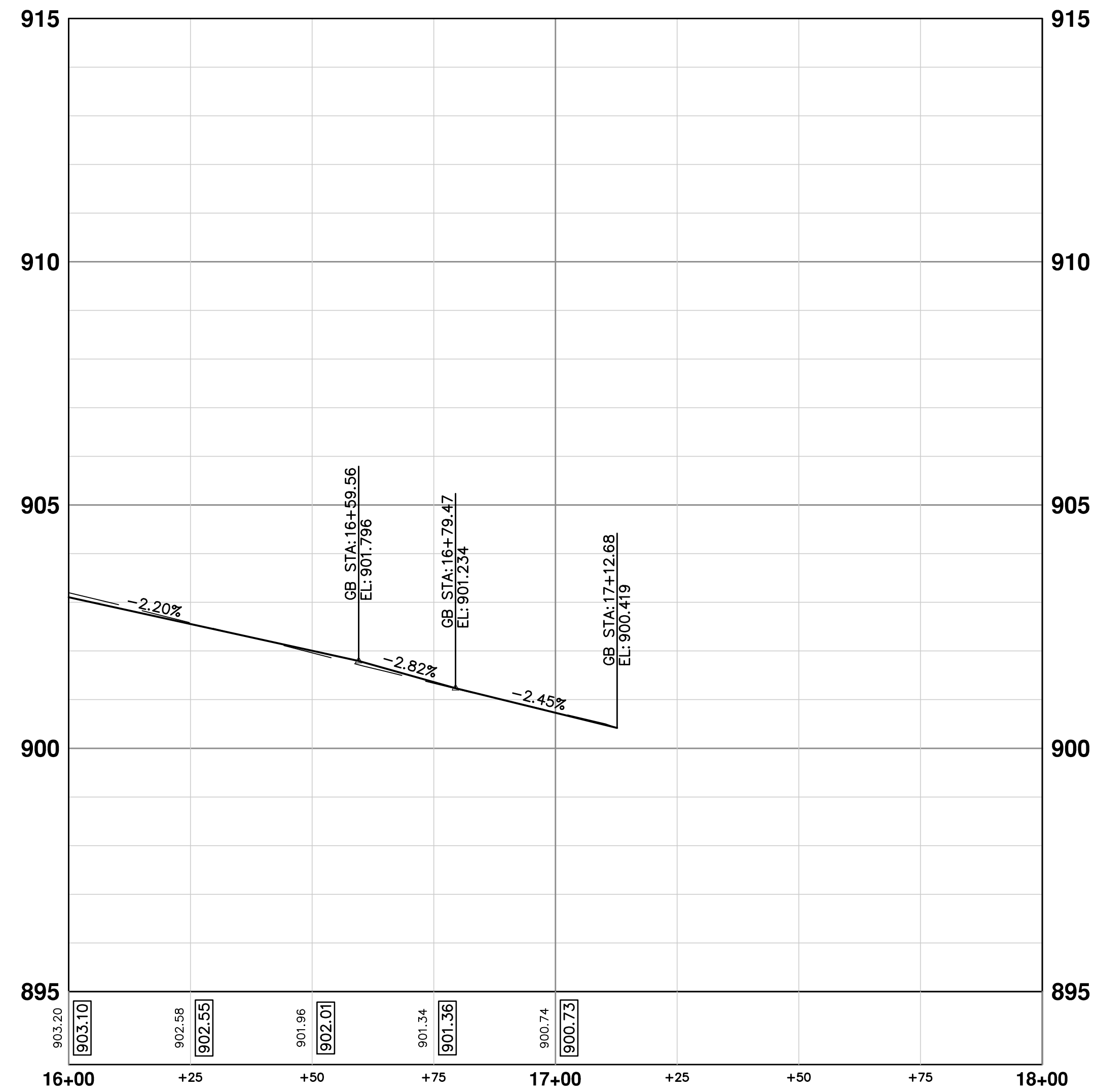

CONSTRUCTION KEY	
KEY	DESCRIPTION
HMA	SURFACE AREA FOR HMA
CG	CURB AND GUTTER, CONC. BARRIER
DO-M	DRIVEWAY OPENING, CONC. TYPE M
DC-8	DRIVE APPROACH, NON-REINF CONC, 8 INCH
SW-4	SIDEWALK, CONC, 4 INCH
SW-6	SIDEWALK, CONC, 6 INCH
SW-8	SIDEWALK, CONC, 8 INCH
SWR-6	SIDEWALK RAMP, CONC, 6 INCH
DWS	DETECTABLE WARNING SURFACE
ABO	ADJUST BY OTHERS
HH	HAND HOLE
MA-F	MAST ARM FOUNDATION
PS-F	PEDESTRIAN SIGNAL FOUNDATION
1	SLOPE RESTORATION*
2	ADJUST GATE VALVE BOX, MONUMENT BOX, OR GAS BOX.
3	ADJUST STRUCTURE COVER
4	DR STRUCTURE, 24 INCH DIA & DR STRUCTURE COVER, TYPE K
5	DOUBLE DR STRUCTURE & DR STRUCTURE COVERS, TYPE K

* THIS ITEM INCLUDES TOPSOIL SURFACE, FURN, 4 INCH; FERTILIZER CHEMICAL NUTRIENT CL A; SEEDING TUF COMPLETE; AND MULCH BLANKET.



REV.	DESCRIPTION	DATE	DRAWN	CHECKED
02	BID SET	2/09/2016	JKA	IVK
01	U OF M REVIEW	11/05/2015	JKA	IVK
00	PROJECT ENGINEER REVIEW	10/02/2015	JKA	IVK

CITY OF ANN ARBOR
PUBLIC SERVICES
301 EAST HURON STREET
ANN ARBOR MI 48106-8647
www.a2gov.org



PROJECT MANAGEMENT - PUBLIC SERVICES - CITY OF ANN ARBOR
OBSERVATORY STREET IMPROVEMENT PROJECT
ROAD
OBSERVATORY 16+00 TO POE

SCALE PLAN: 1" = 20'
PROFILE: 1" = 2'

DRAWING No. 2015025-28

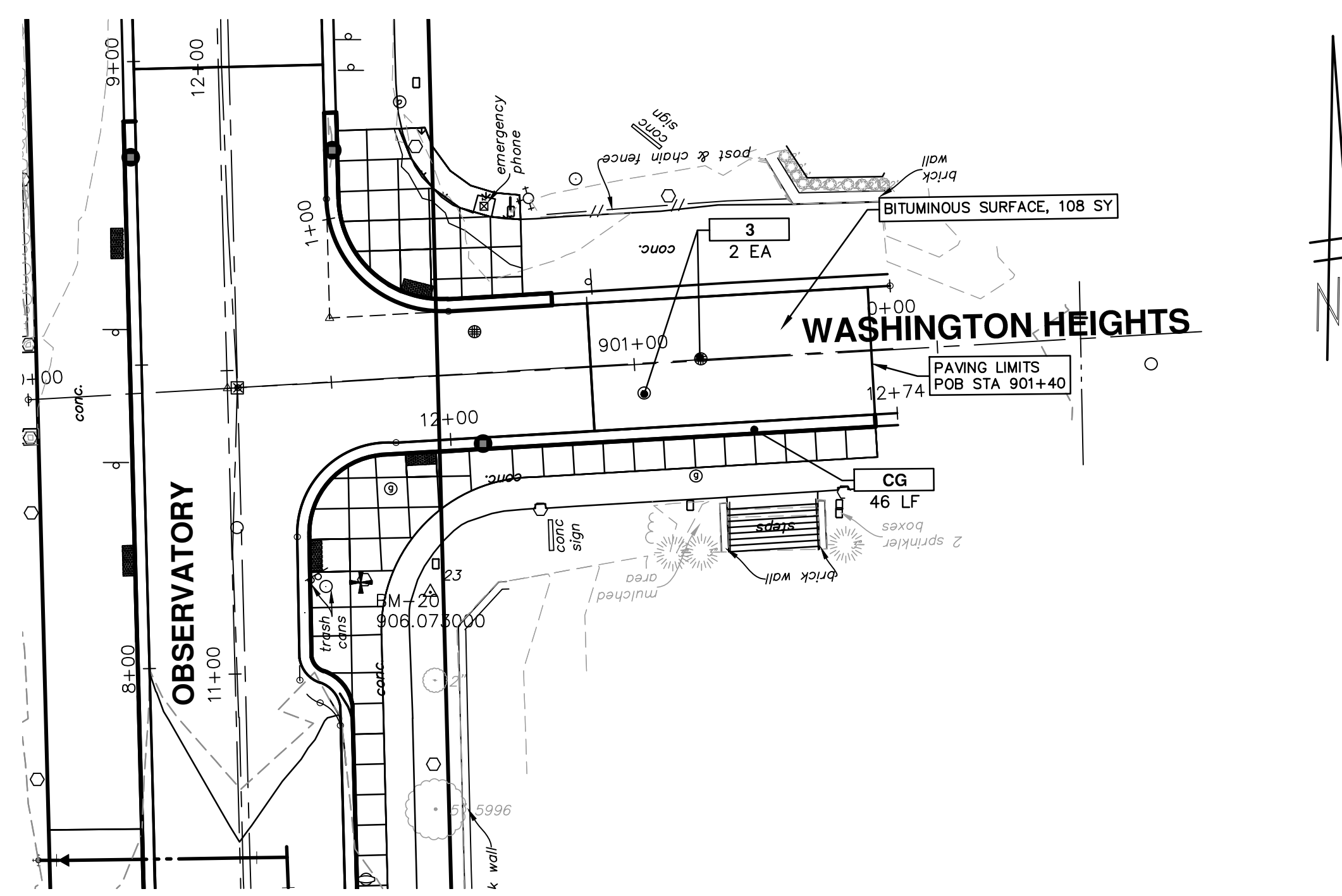
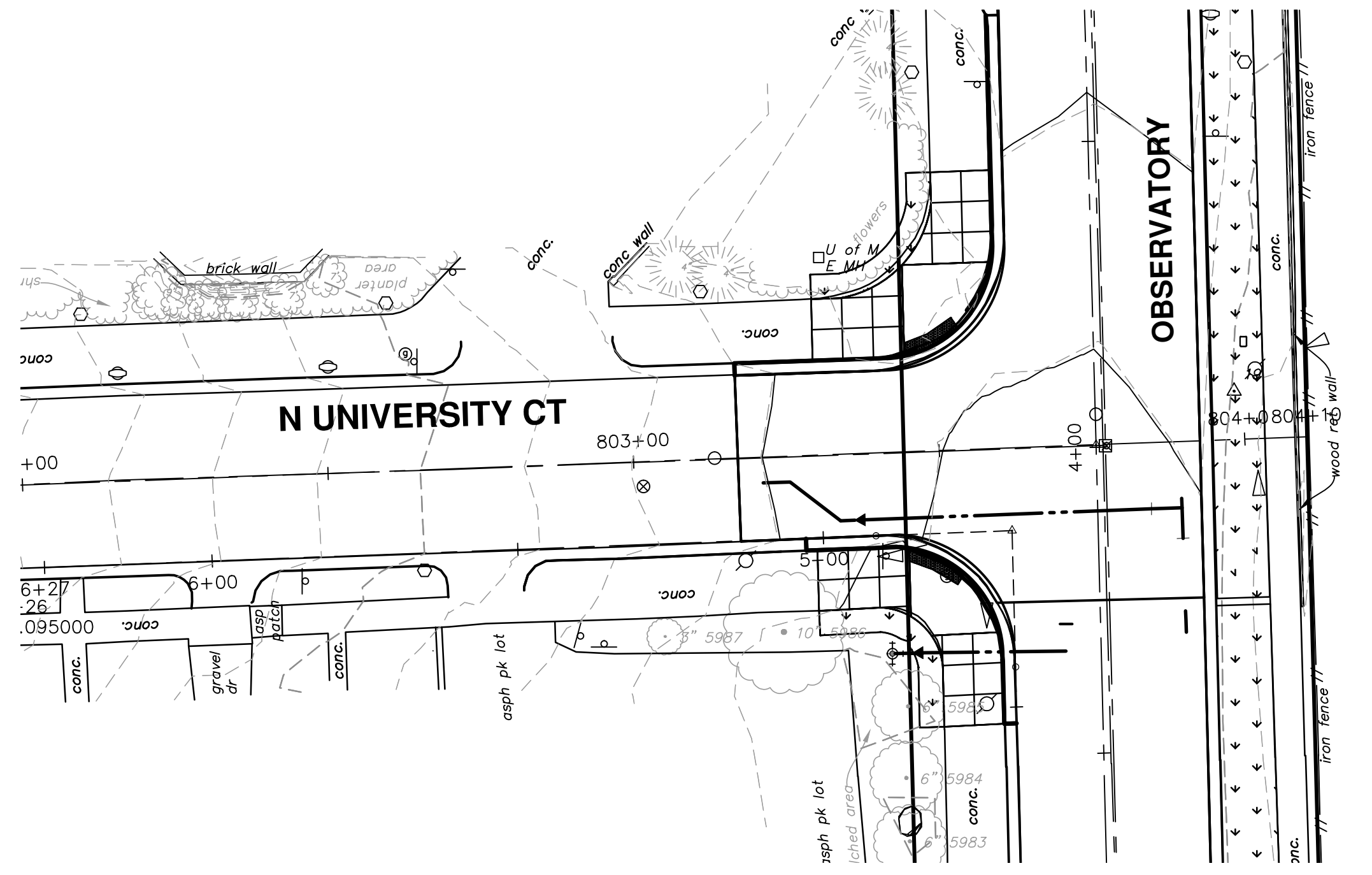

N UNIVERSITY CT

WASHINGTON HEIGHTS

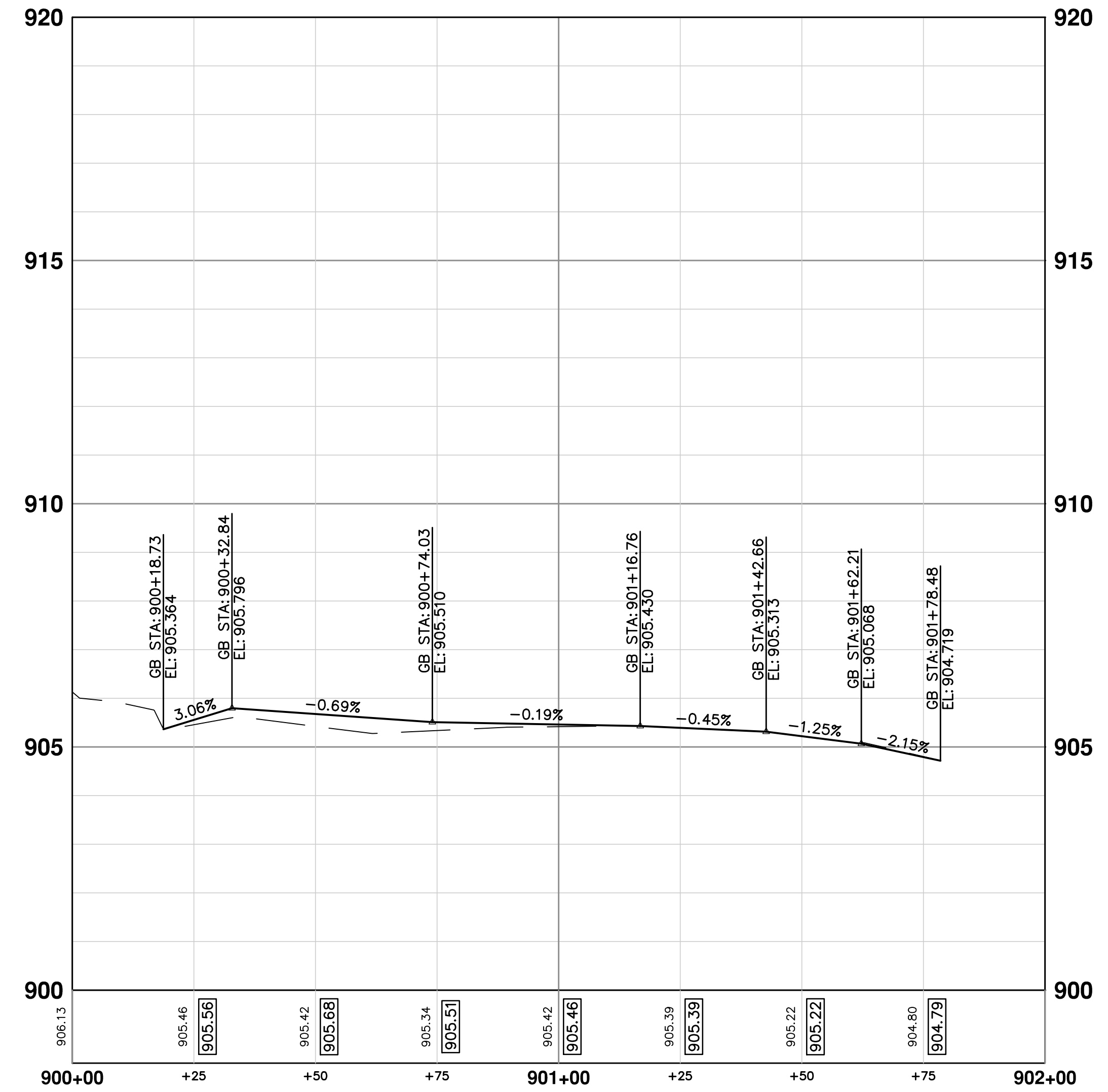
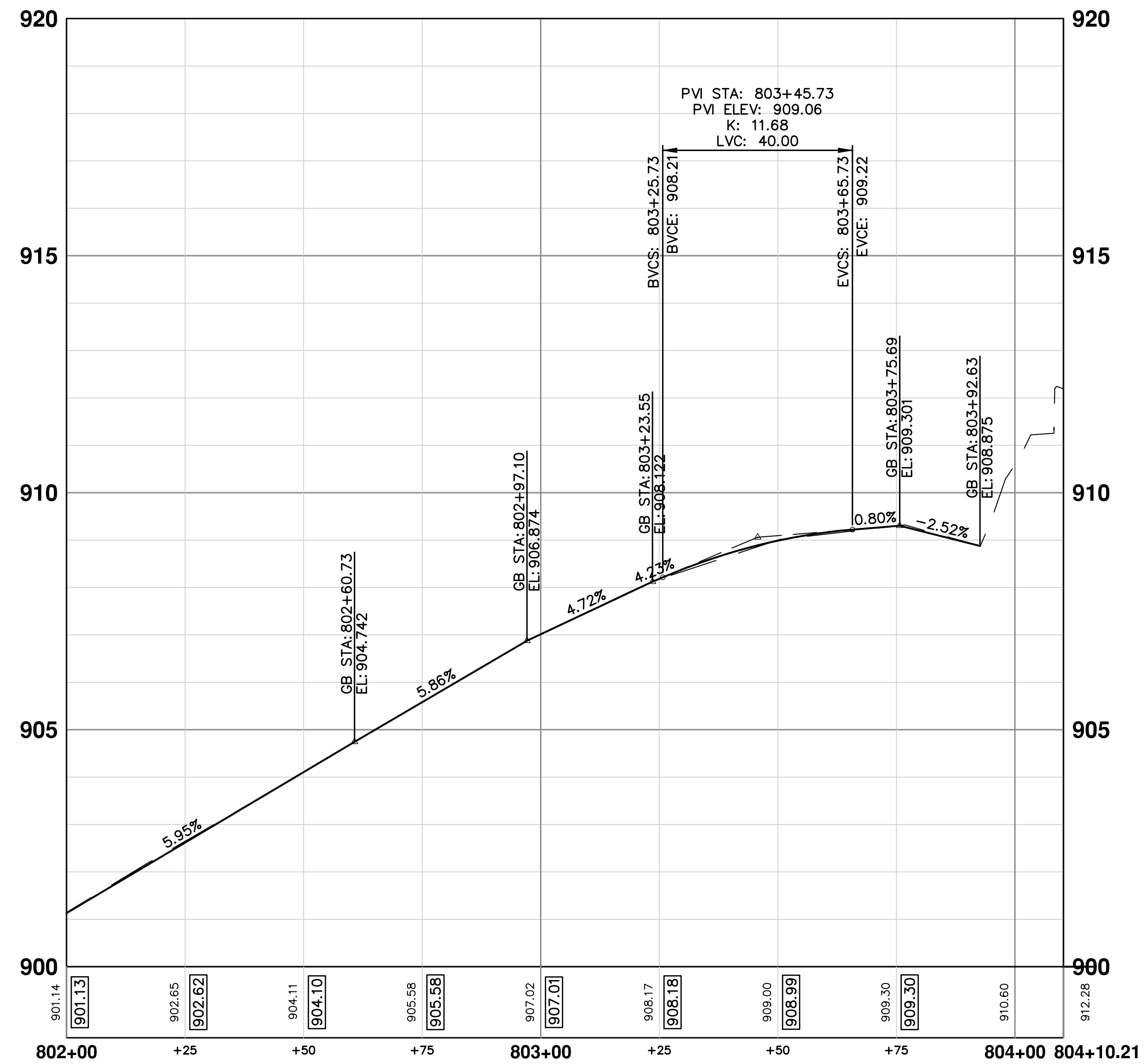

CONSTRUCTION KEY	
KEY	DESCRIPTION
HMA	SURFACE AREA FOR HMA
CG	CURB AND GUTTER, CONC. BARRIER
DO-M	DRIVEWAY OPENING, CONC. TYPE M
DC-8	DRIVE APPROACH, NON-REINF CONC, 8 INCH
SW-4	SIDEWALK, CONC, 4 INCH
SW-6	SIDEWALK, CONC, 6 INCH
SW-8	SIDEWALK, CONC, 8 INCH
SWR-6	SIDEWALK RAMP, CONC, 6 INCH
DWS	DETECTABLE WARNING SURFACE
ABO	ADJUST BY OTHERS
HH	HAND HOLE
MA-F	MAST ARM FOUNDATION
PS-F	PEDESTRIAN SIGNAL FOUNDATION
1	SLOPE RESTORATION*
2	ADJUST GATE VALVE BOX, MONUMENT BOX, OR GAS BOX.
3	ADJUST STRUCTURE COVER
4	DR STRUCTURE, 24 INCH DIA & DR STRUCTURE COVER, TYPE K
5	DOUBLE DR STRUCTURE & DR STRUCTURE COVERS, TYPE K

* THIS ITEM INCLUDES TOPSOIL SURFACE, FURN, 4 INCH; FERTILIZER CHEMICAL NUTRIENT CL A; SEEDING TUF COMPLETE; AND MULCH BLANKET.

Know what's below.
Call Before you dig.

IVK	IVK	IVK	IVK	IVK	CHECKED
JKA	JKA	JKA	JKA	JKA	DRAWN
2/09/2016	11/05/2015	10/02/2015			DATE
BID SET	U OF M REVIEW	PROJECT ENGINEER REVIEW			REV.
02	01	00			

CITY OF ANN ARBOR
PUBLIC SERVICES
301 EAST HURON STREET
ANN ARBOR, MI 48106-0647
www.a2gov.org

PROJECT MANAGEMENT - PUBLIC SERVICES - CITY OF ANN ARBOR
OBSERVATORY STREET IMPROVEMENT PROJECT
ROAD
N UNIVERSITY CT & WASHINGTON HEIGHTS

SCALE PLAN: 1" = 20'
PROFILE: 1" = 2'
DRAWING No. **2015025-29**

SHEET No. **29 OF 40**

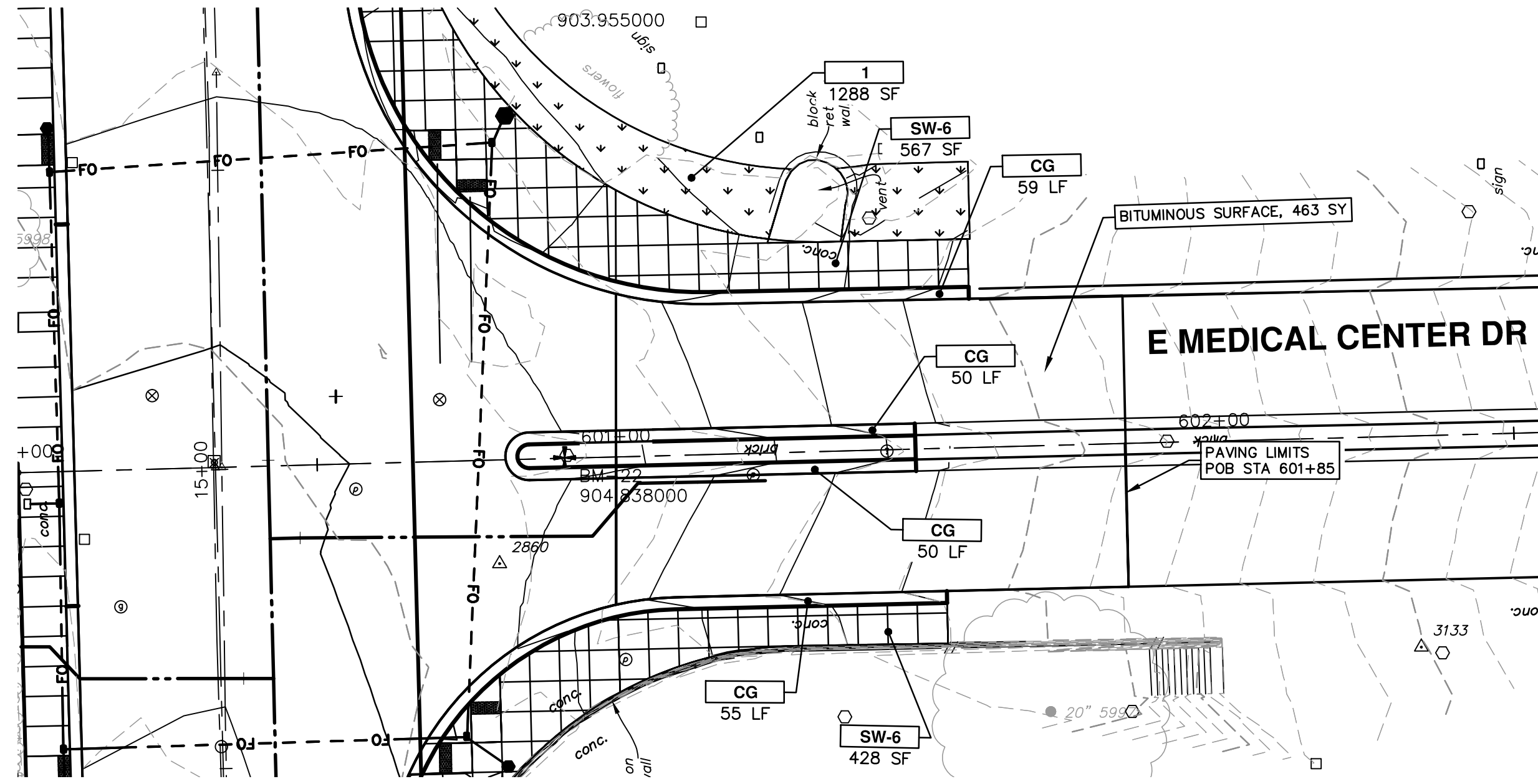

E MEDICAL

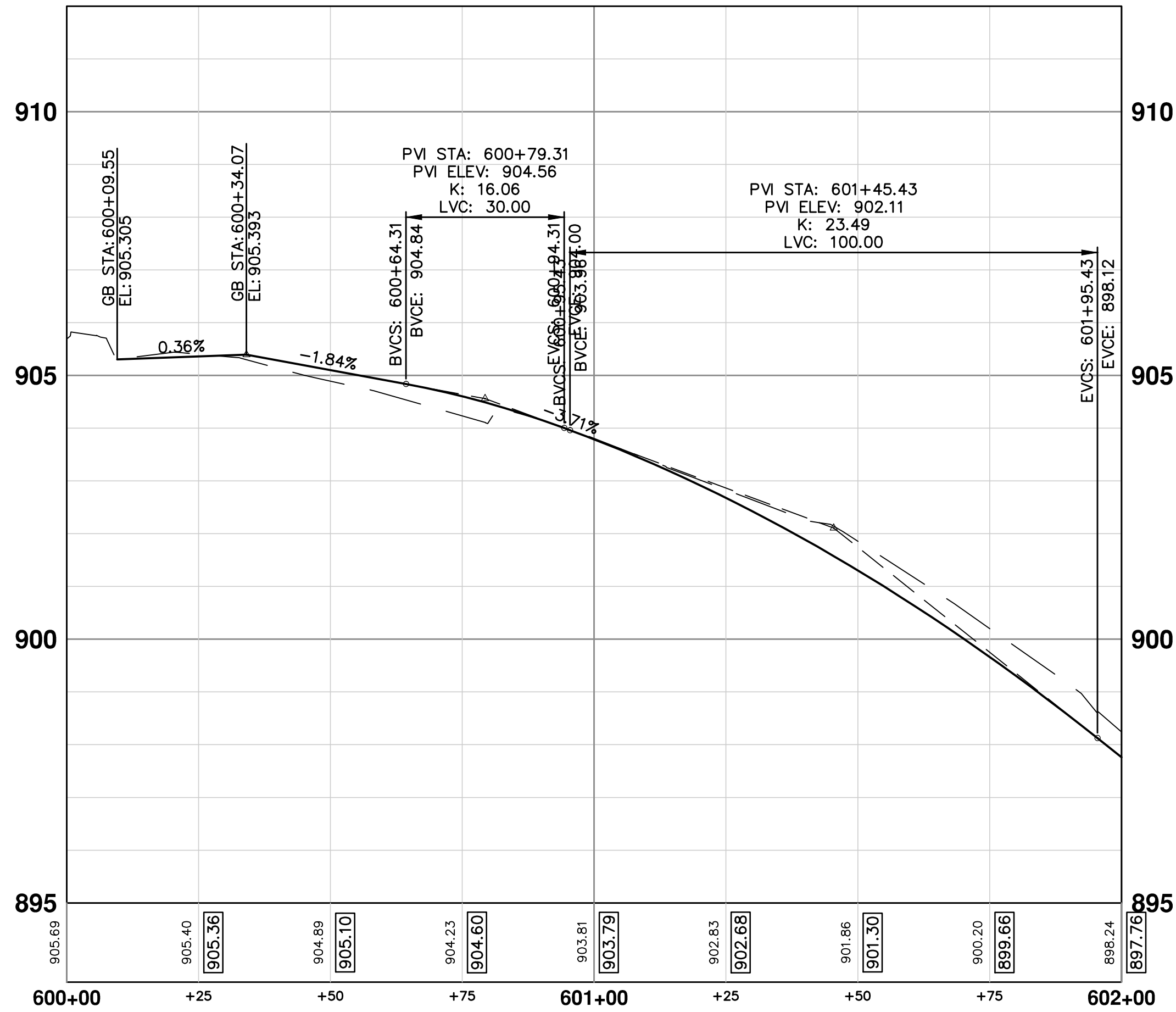

CONSTRUCTION KEY	
KEY	DESCRIPTION
HMA	SURFACE AREA FOR HMA
CG	CURB AND GUTTER, CONC. BARRIER
DO-M	DRIVEWAY OPENING, CONC. TYPE M
DC-8	DRIVE APPROACH, NON-REINF CONC. 8 INCH
SW-4	SIDEWALK, CONC. 4 INCH
SW-6	SIDEWALK, CONC. 6 INCH
SW-8	SIDEWALK, CONC. 8 INCH
SWR-6	SIDEWALK RAMP, CONC. 6 INCH
DWS	DETECTABLE WARNING SURFACE
ABO	ADJUST BY OTHERS
HH	HAND HOLE
MA-F	MAST ARM FOUNDATION
PS-F	PEDESTRIAN SIGNAL FOUNDATION
1	SLOPE RESTORATION*
2	ADJUST GATE VALVE BOX, MONUMENT BOX, OR GAS BOX.
3	ADJUST STRUCTURE COVER
4	DR STRUCTURE, 24 INCH DIA & DR STRUCTURE COVER, TYPE K
5	DOUBLE DR STRUCTURE & DR STRUCTURE COVERS, TYPE K

* THIS ITEM INCLUDES TOPSOIL SURFACE, FURN, 4 INCH; FERTILIZER CHEMICAL NUTRIENT CL A; SEEDING TUF COMPLETE; AND MULCH BLANKET.



CITY OF ANN ARBOR
PUBLIC SERVICES
301 EAST HURON STREET
ANN ARBOR MI 48106-2667
www.a2gov.org

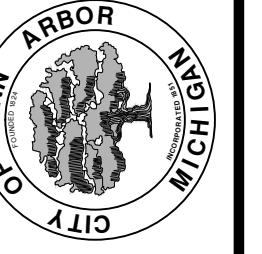

PROJECT MANAGEMENT - PUBLIC SERVICES - CITY OF ANN ARBOR
OBSERVATORY STREET IMPROVEMENT PROJECT
ROAD
E MEDICAL CENTER DR

SCALE PLAN: 1" = 20'
PROFILE: 1" = 2'
DRAWING No. 2015025-30

S:\Project Management\Design\2015025 Observatory\Plan Production\2015025\NT.dwg Dwg Created: 2-Feb-16 - _g2 standard bw.stb - Plot Date: 12-Feb-16

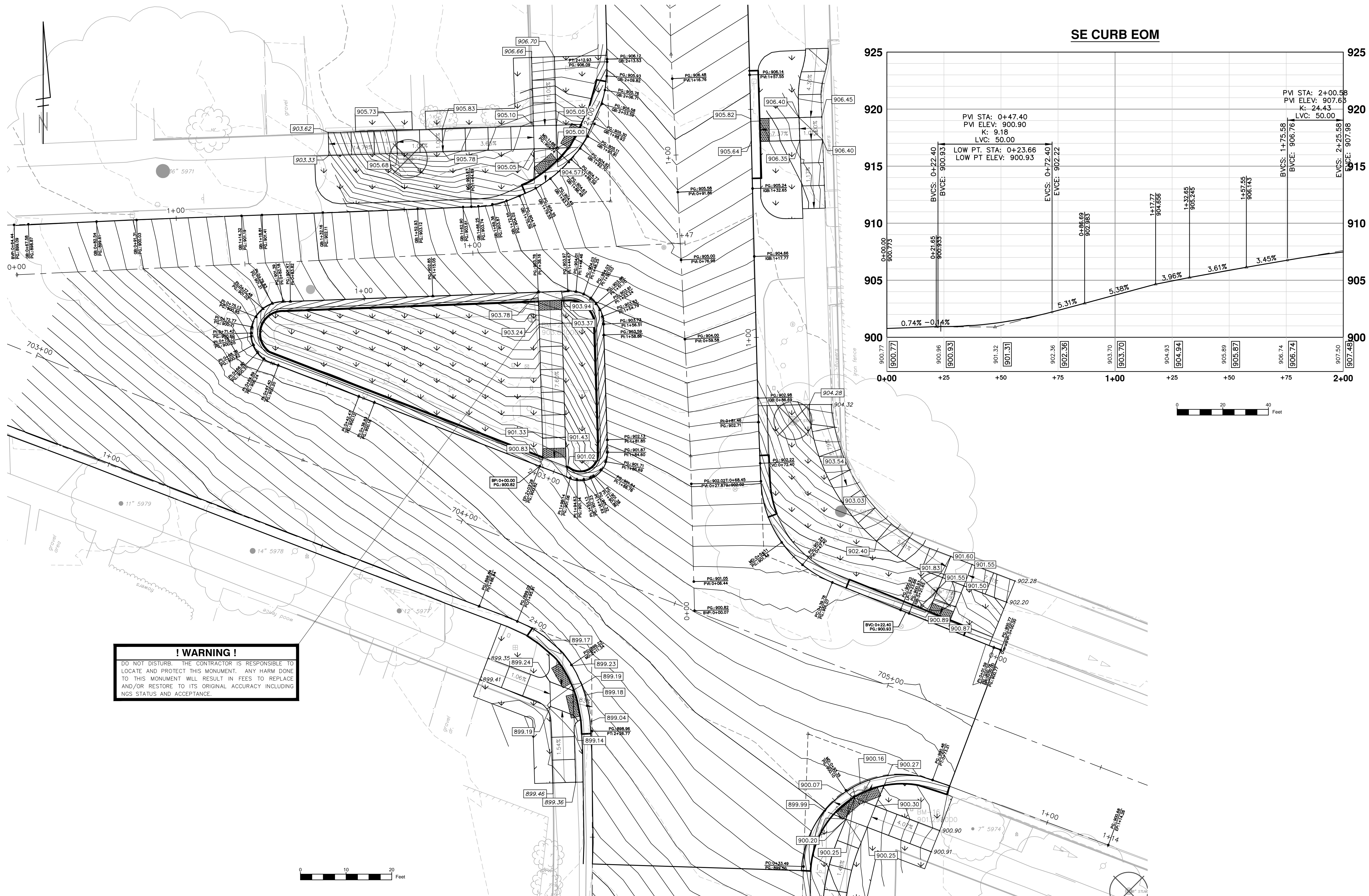

SE CURB EOM

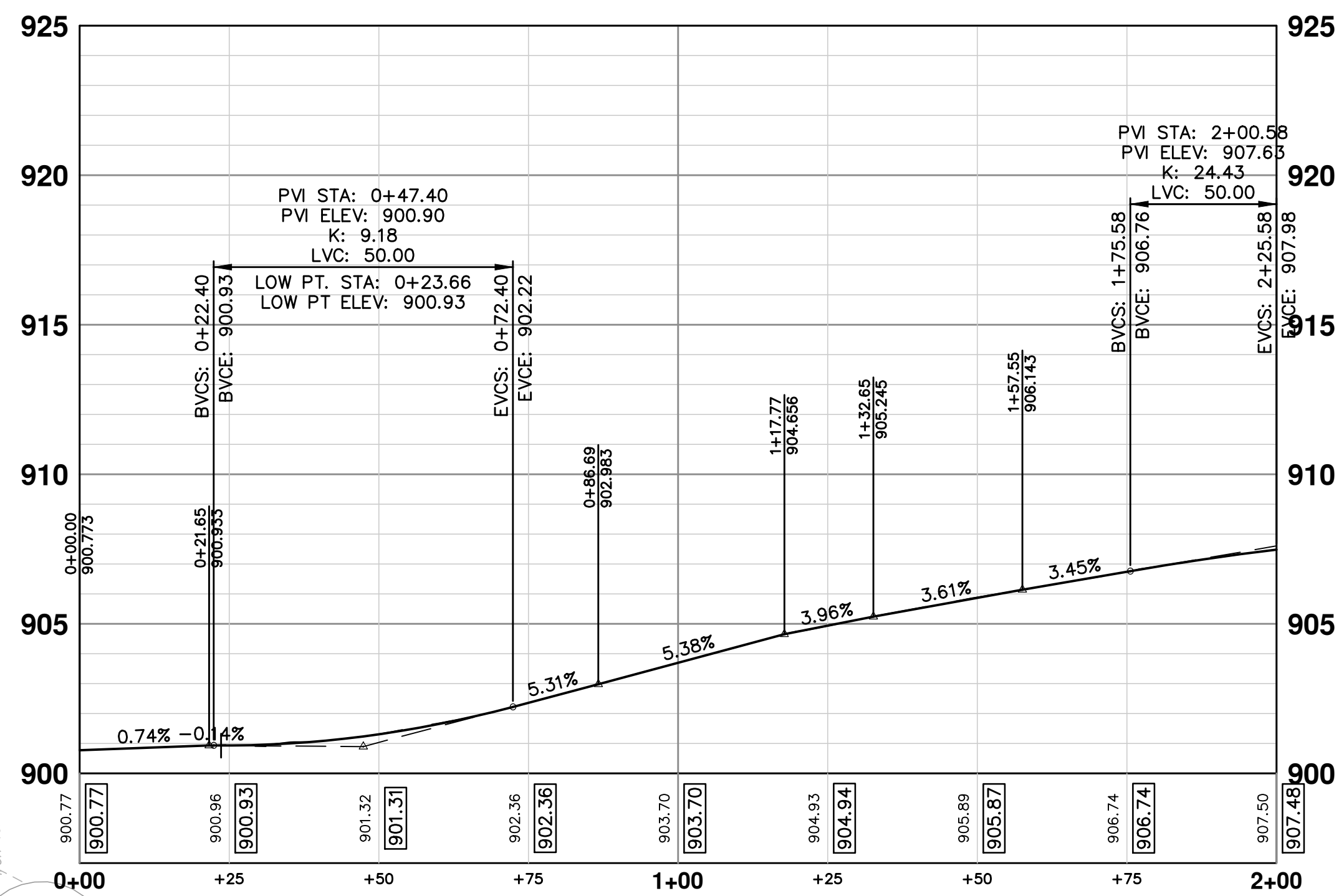

! WARNING !
 DO NOT DISTURB. THE CONTRACTOR IS RESPONSIBLE TO LOCATE AND PROTECT THIS MONUMENT. ANY HARM DONE TO THIS MONUMENT WILL RESULT IN FEES TO REPLACE AND/OR RESTORE TO ITS ORIGINAL ACCURACY INCLUDING NGS STATUS AND ACCEPTANCE.

PROJECT MANAGEMENT - PUBLIC SERVICES - CITY OF ANN ARBOR
OBSERVATORY STREET IMPROVEMENT PROJECT
 INTERSECTIONS
 GEDES

SCALE PLAN: 1" = 10'
 PROFILE: 1" = 4'

DRAWING No. **2015025-31**

SHEET No. **31 OF 40**

811
 Know what's below.
 Call Before you dig.

REV.	DATE	DRAWN	CHECKED	DESCRIPTION
02	2/09/2016	JKA	IVK	BID SET
01	11/05/2015	JKA	IVK	U OF M REVIEW
00	10/02/2015	JKA	IVK	PROJECT ENGINEER REVIEW

CITY OF ANN ARBOR
 PUBLIC SERVICES
 301 EAST HURON STREET
 ANN ARBOR MI 48106-6647
 ANN ARBOR 734-794-4410
 www.aagov.org

S:\Project Management\Design\2015025 Observatory\Plan Production\2015025NT.dwg Dwg Created: 2-Feb-16 - _g2 standard bw.stb - Plot Date: 12-Feb-16

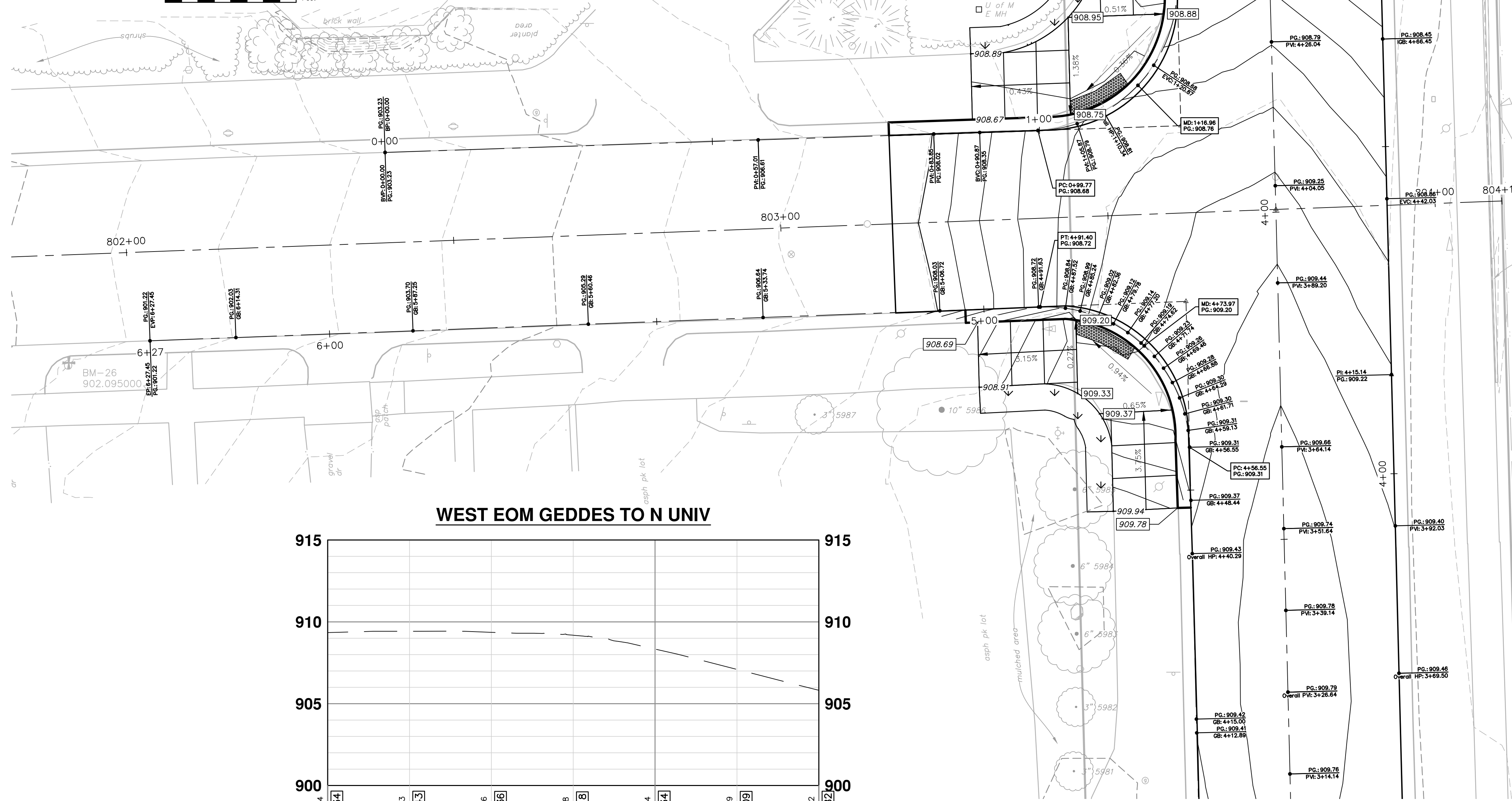
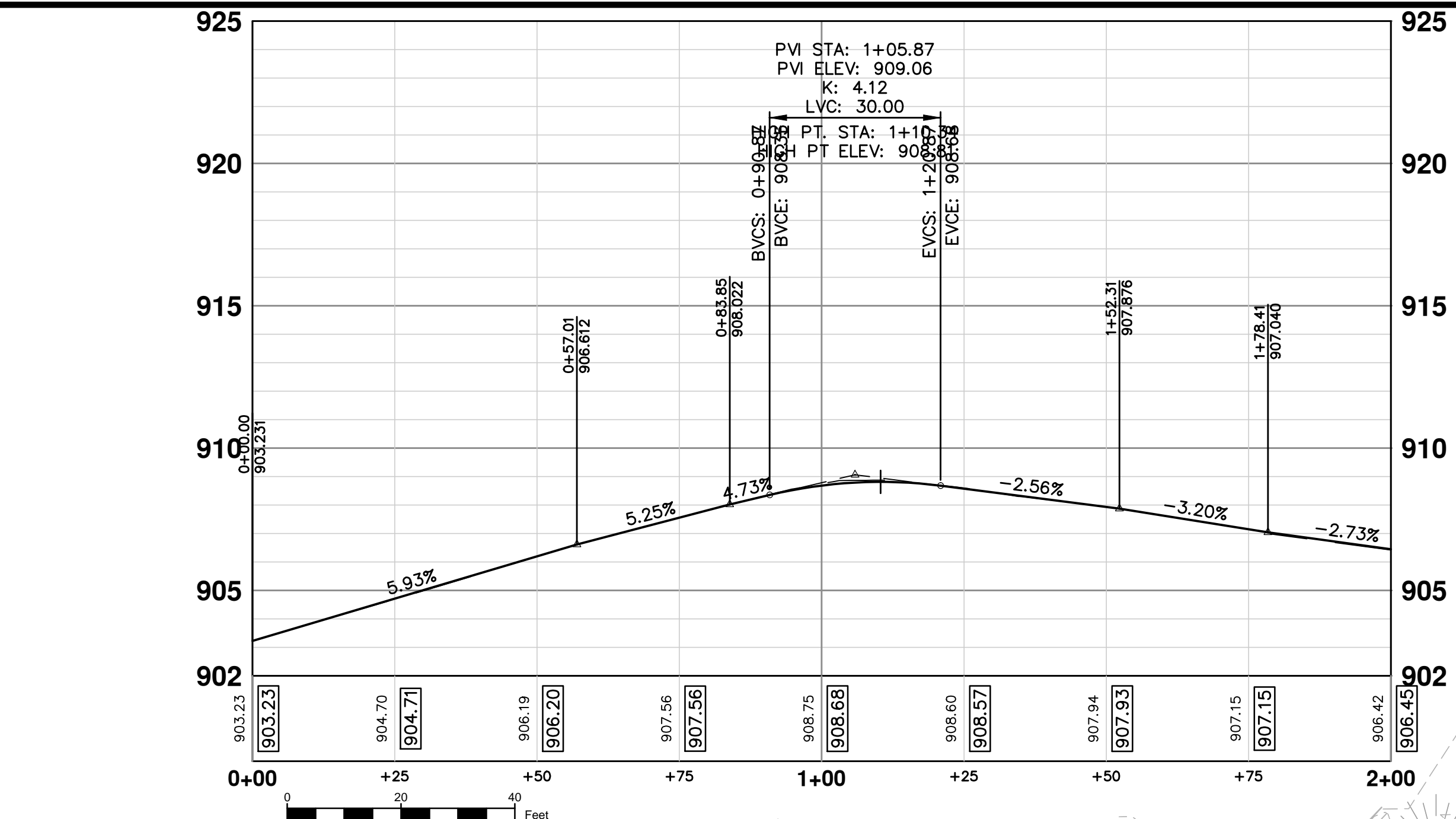

WEST EOM GEDDES TO N UNIV

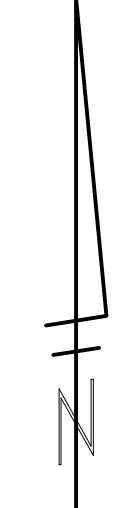
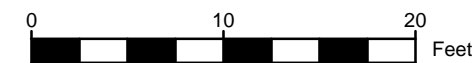
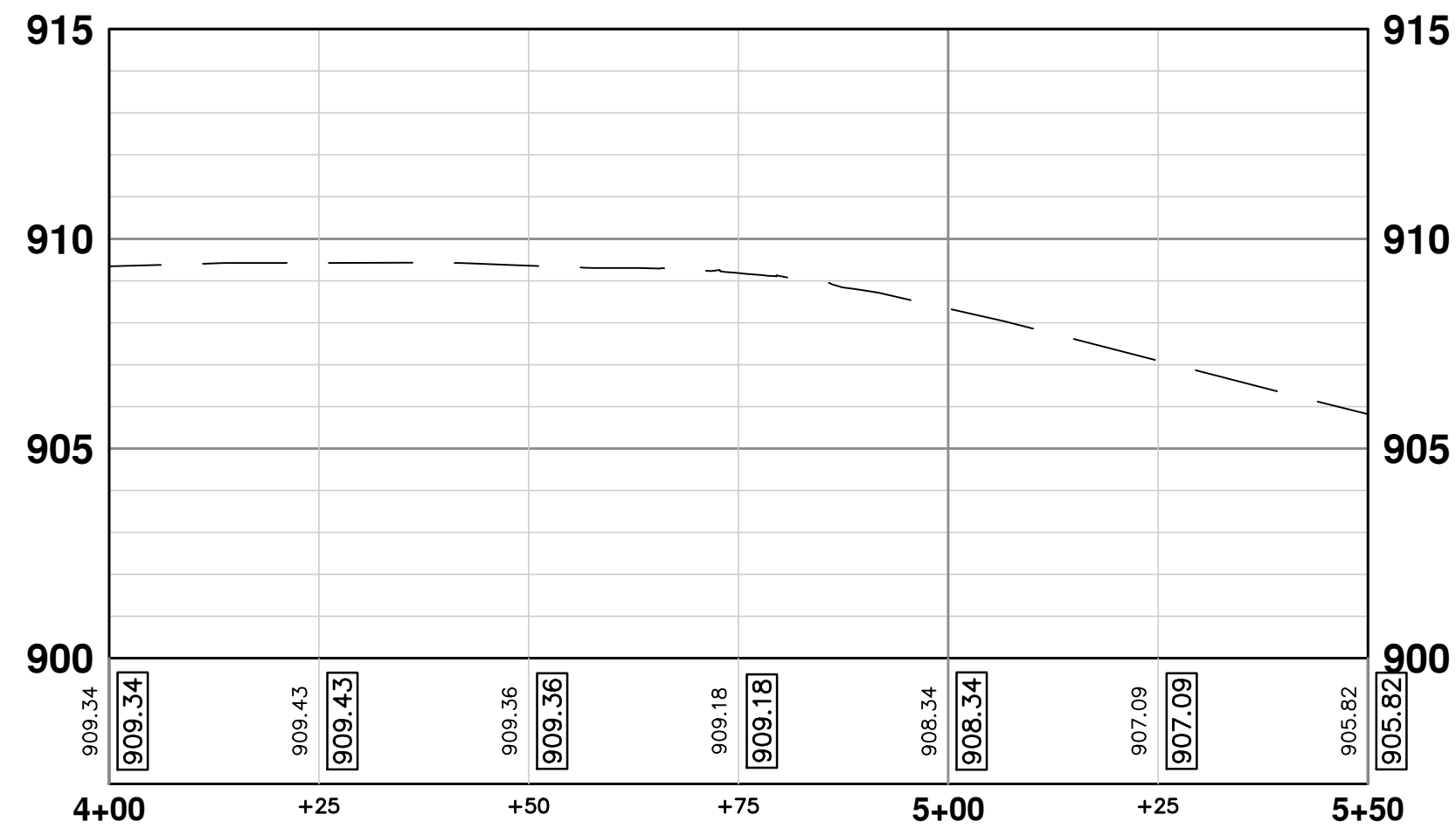

PROJECT MANAGEMENT - PUBLIC SERVICES - CITY OF ANN ARBOR
INTERSECTIONS
OBSERVATORY STREET IMPROVEMENT PROJECT
N UNIVERSITY CT

SCALE PLAN: 1" = 10'
 PROFILE: 1" = 4'
 DRAWING No. 2015025-32

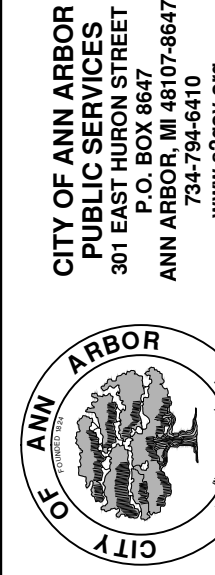

CITY OF ANN ARBOR
 PUBLIC SERVICES
 301 EAST HURON STREET
 ANN ARBOR, MI 48106-8647
 www.a2gov.org

REV.	DATE	DESCRIPTION
00	10/02/2015	PROJECT ENGINEER REVIEW
01	11/05/2015	U OF M REVIEW
02	2/09/2016	BID SET

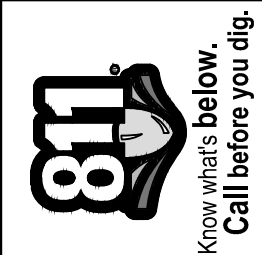

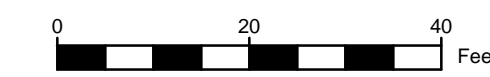
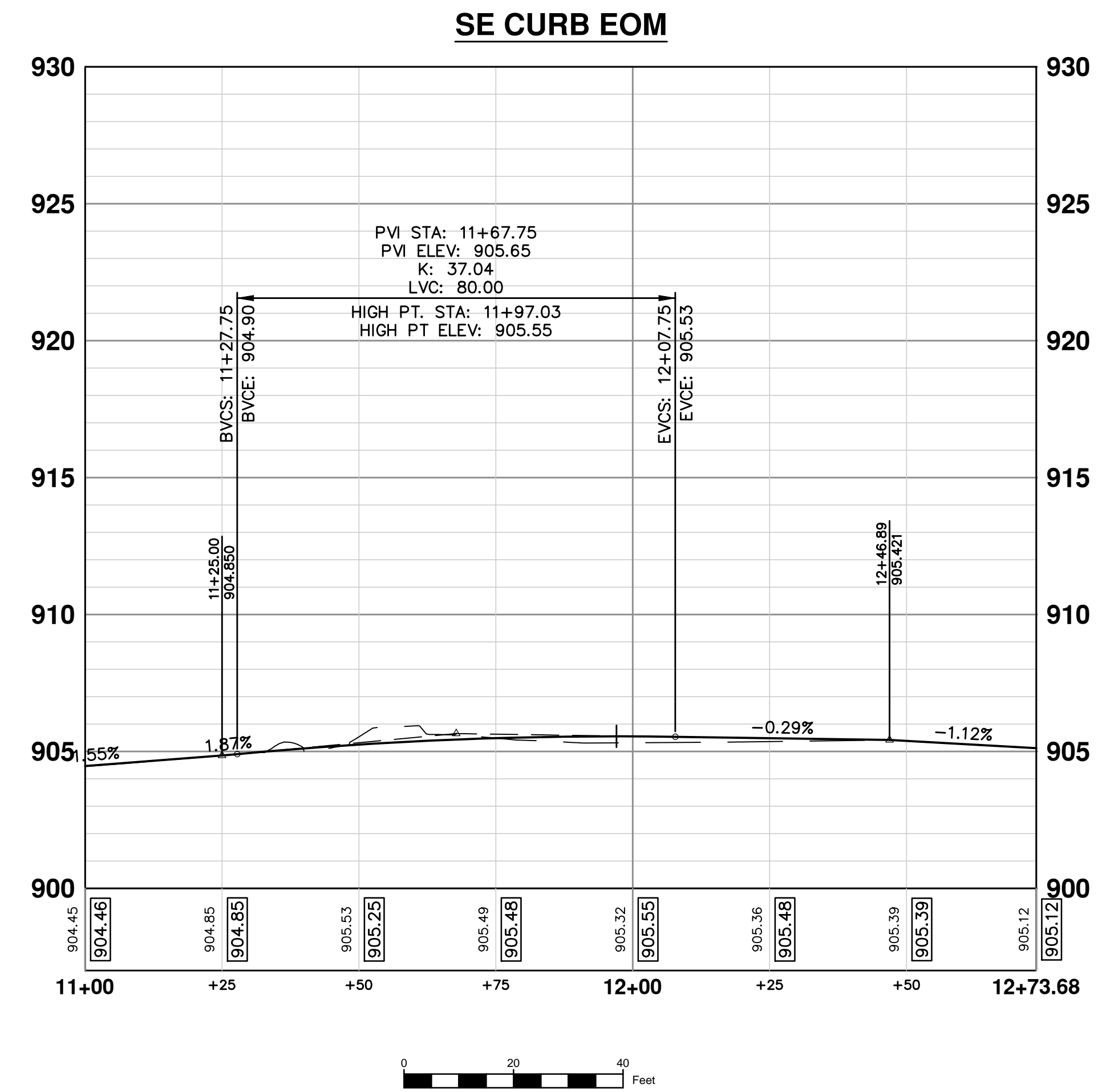
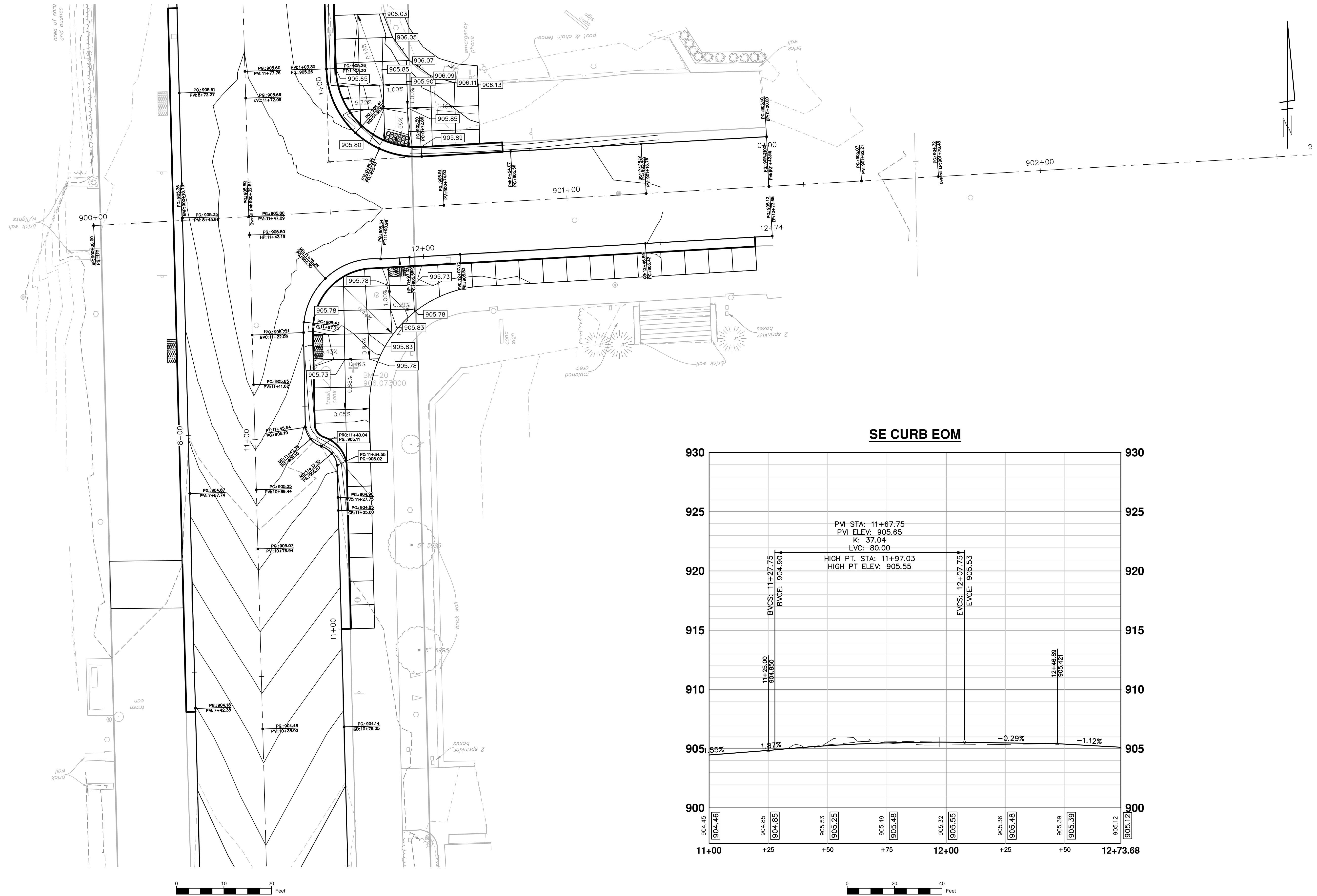

PROJECT MANAGEMENT - PUBLIC SERVICES - CITY OF ANN ARBOR
OBSERVATORY STREET IMPROVEMENT PROJECT
 INTERSECTIONS
 S HALF WASHINGTON HEIGHTS

SCALE PLAN: 1" = 10'
 PROFILE: 1" = 4'

DRAWING No.
2015025-33

811
 Know what's below.
 Call Before you dig.

REV.	DESCRIPTION	DATE	DRAWN	CHECKED
02	BID SET	2/09/2016	JKA	IVK
01	U OF M REVIEW	11/05/2015	JKA	IVK
00	PROJECT ENGINEER REVIEW	10/02/2015	JKA	IVK

CITY OF ANN ARBOR
 PUBLIC SERVICES
 301 EAST HURON STREET
 ANN ARBOR, MI 48106-8647
 ANN ARBOR 734-794-4410
 www.a2gov.org

SHEET No.
33 OF 40

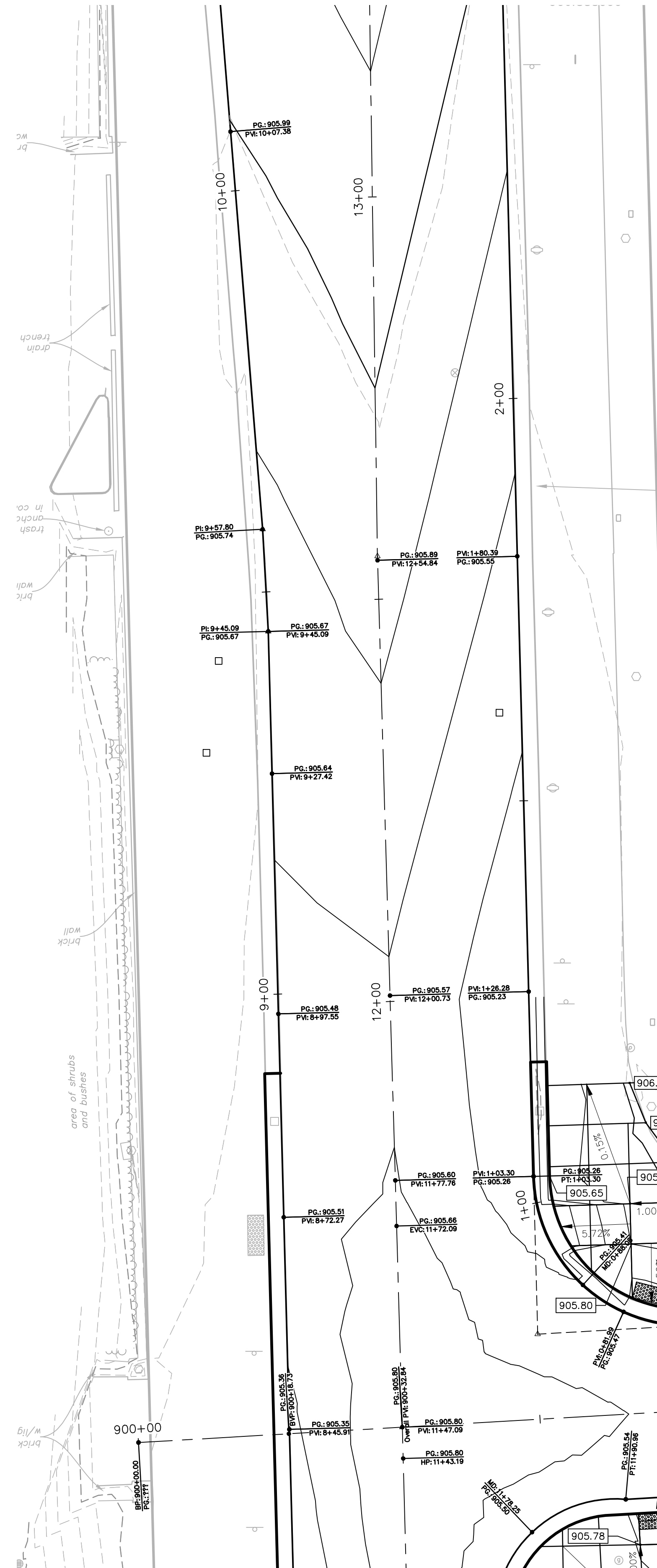

BRASS TABLET MARKING
UNDERGROUND CABLE
UNIVERSITY OF MICHIGAN
1/2" x 3/4" x 3/4" (3")
BURIED 3 FT. DOWN

ME CURB EOM

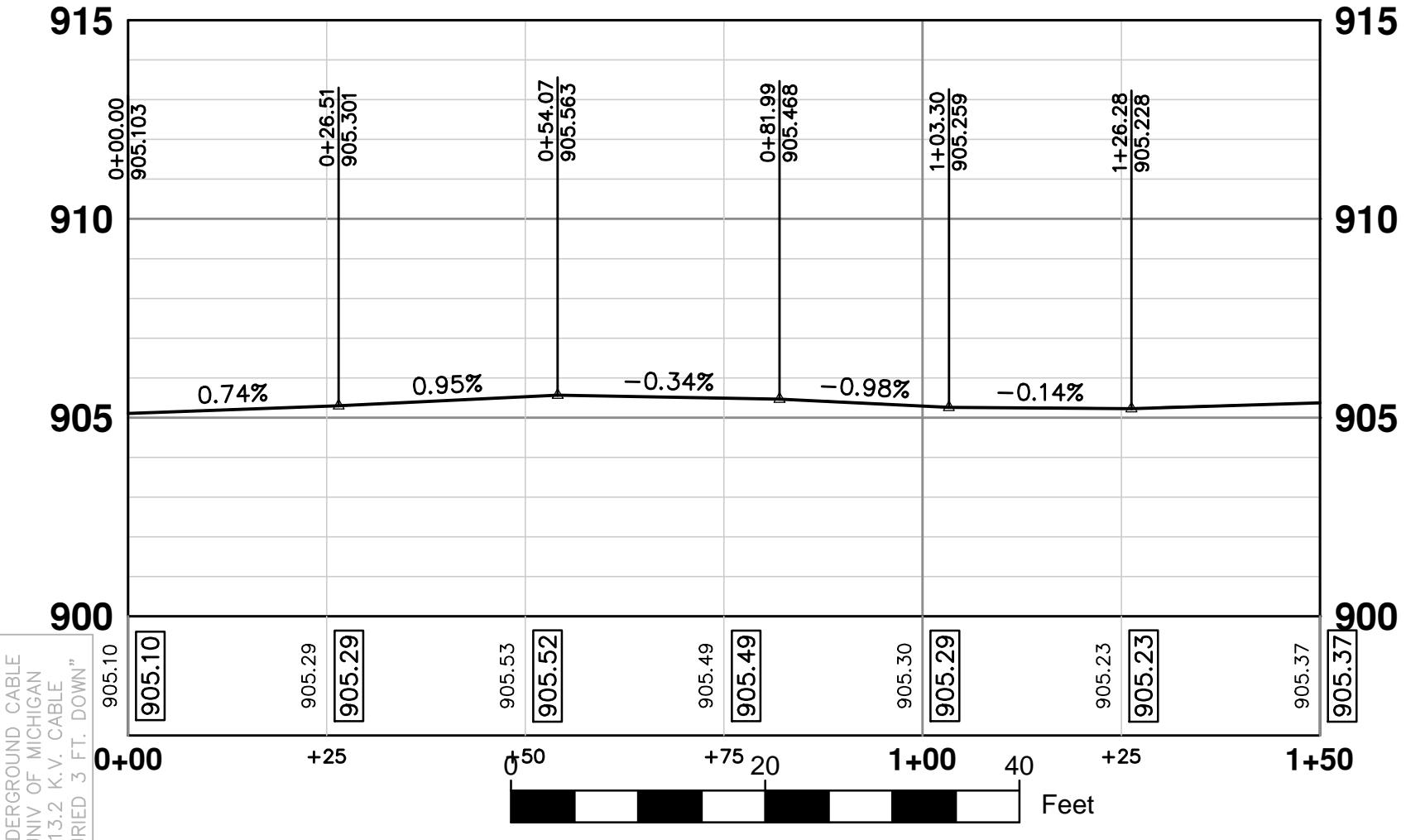

WASHINGTON HEIGHTS

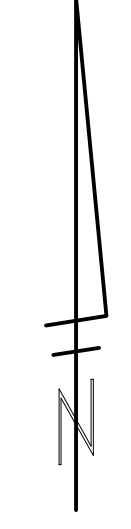
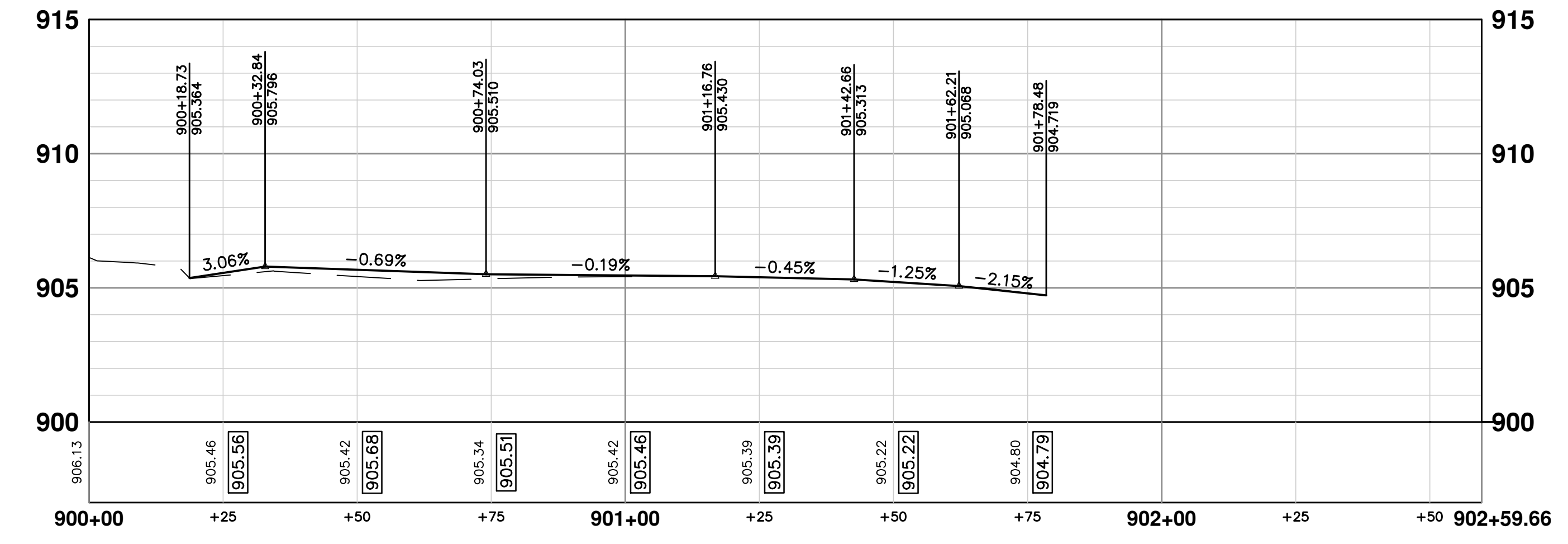

PROJECT MANAGEMENT - PUBLIC SERVICES - CITY OF ANN ARBOR
OBSERVATORY STREET IMPROVEMENT PROJECT
INTERSECTIONS
N HALF OF WASHINGTON HEIGHTS

SCALE PLAN: 1" = 10'
PROFILE: 1" = 4'

DRAWING No. 2015025-34

SHEET No. 34 OF 40

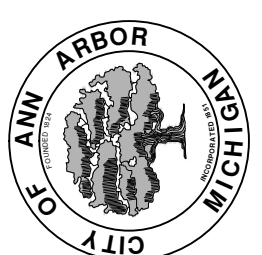

CITY OF ANN ARBOR
PUBLIC SERVICES
301 EAST HURON STREET
ANN ARBOR, MI 48106-8647
www.a2gov.org

REV.	DESCRIPTION	DATE	DRAWN	CHECKED
00	PROJECT ENGINEER REVIEW	10/02/2015	JKA	IVK
01	U OF M REVIEW	11/05/2015	JKA	IVK
02	BID SET	2/09/2016	JKA	IVK

811
Know what's below.
Call Before you dig.

S:\Project Management\Design\2015025 Observatory\Plan Production\2015025\NT.dwg Dwg Created: 2-Feb-16 - _g2 standard bw.stb - Plot Date: 12-Feb-16

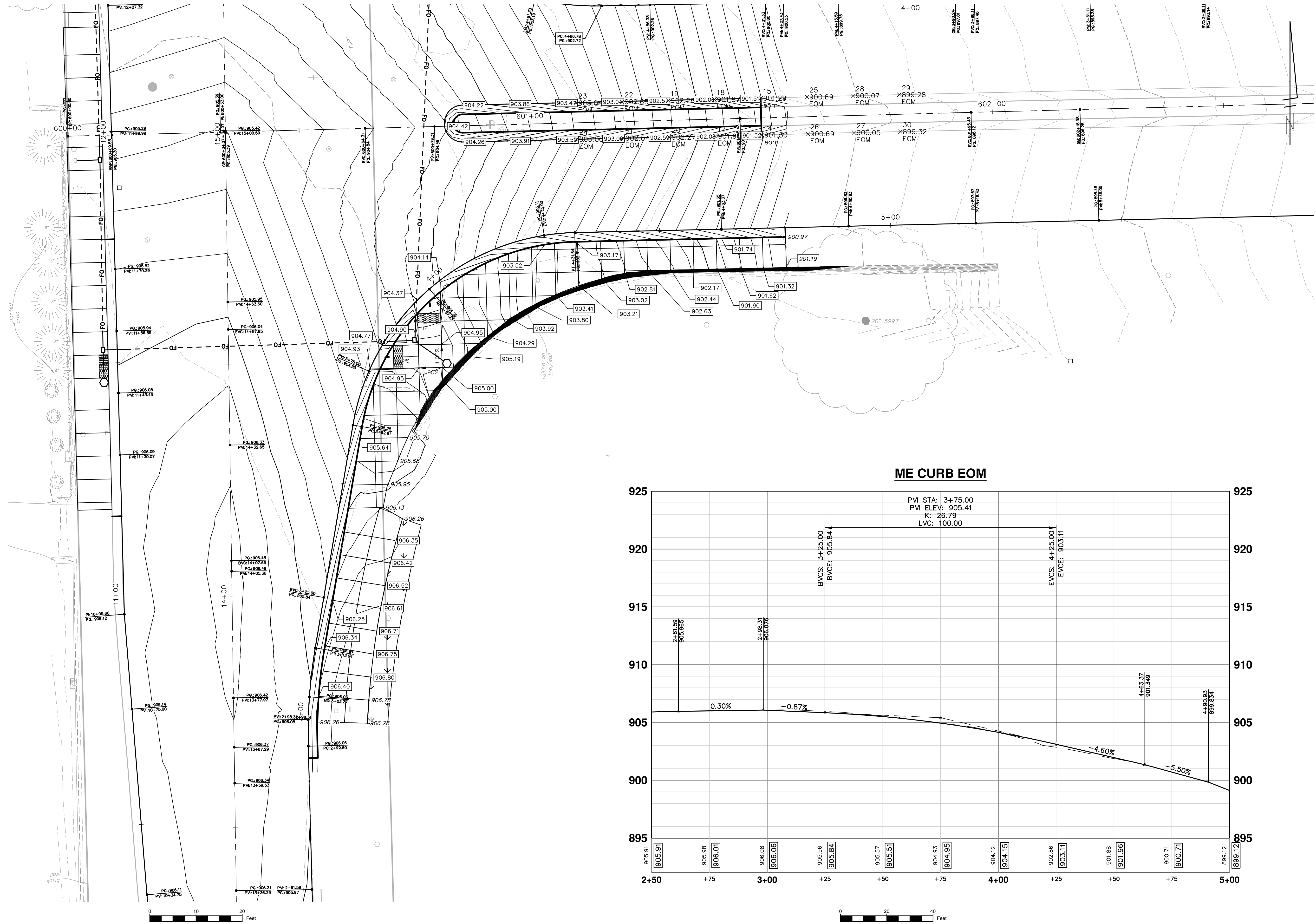

ME CURB EOM

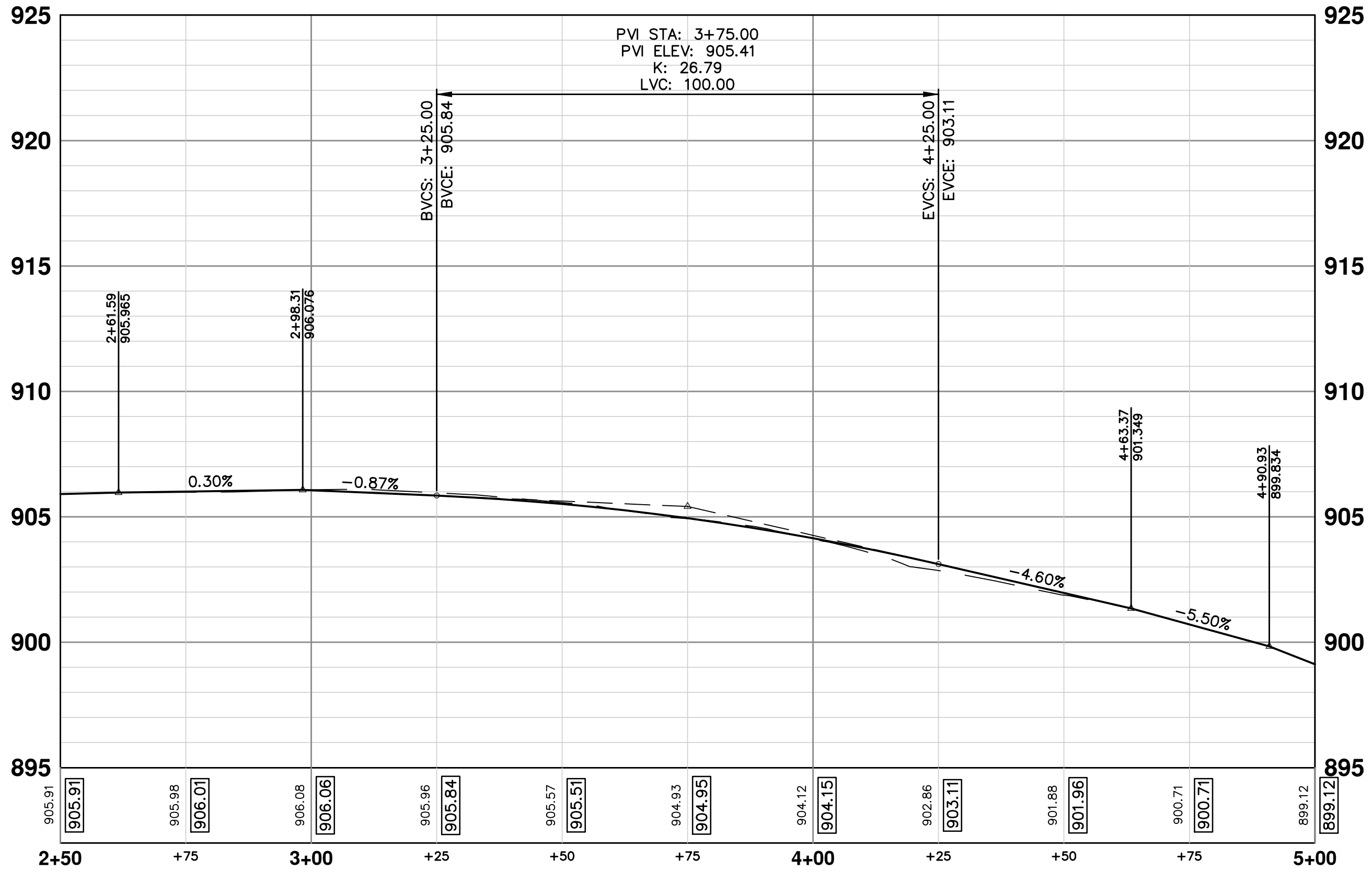

REV.	DESCRIPTION	DATE	DRAWN	CHECKED
02	BID SET	2/09/2016	JKA	IVK
01	U OF M REVIEW	11/05/2015	JKA	IVK
00	PROJECT ENGINEER REVIEW	10/02/2015	JKA	IVK

CITY OF ANN ARBOR
PUBLIC SERVICES
301 EAST HURON STREET
ANN ARBOR MI 48106-0667
www.a2gov.org

PROJECT MANAGEMENT - CITY OF ANN ARBOR
OBSERVATORY STREET IMPROVEMENT PROJECT
INTERSECTIONS
S HALF E MEDICAL CENTER DR

S:\Project Management\Design\2015025 Observatory\Plan Production\2015025\NT.dwg Dwg Created: 2-Feb-16 - _g2 standard bw.stb - Plot Date: 12-Feb-16

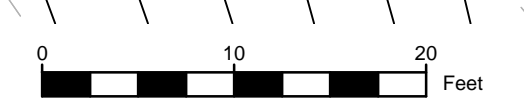
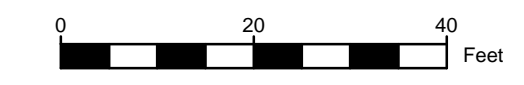
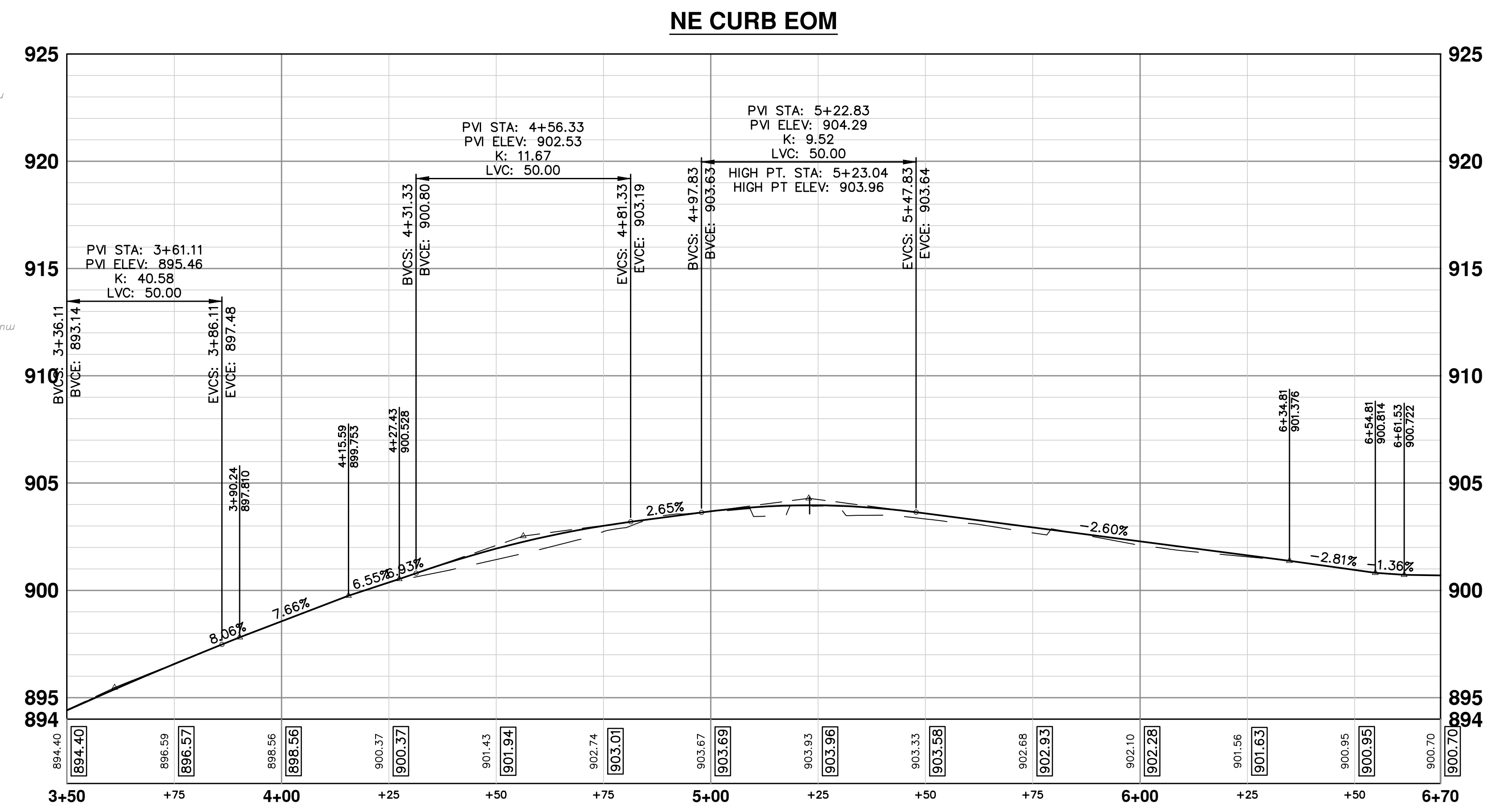
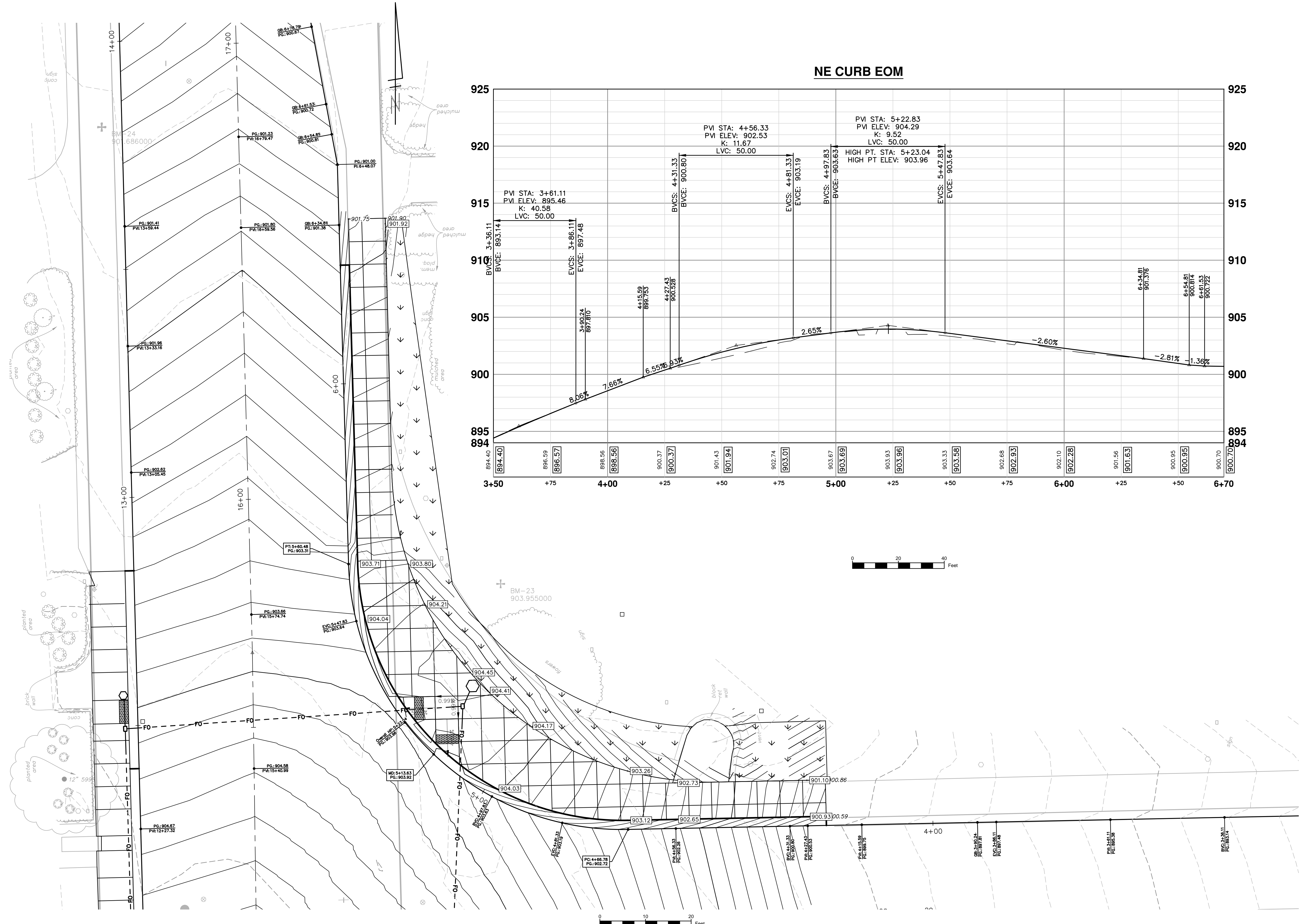

PROJECT MANAGEMENT - PUBLIC SERVICES - CITY OF ANN ARBOR
OBSERVATORY STREET IMPROVEMENT PROJECT
 INTERSECTIONS
 N HALF MEDICAL CENTER DR

SCALE PLAN: 1" = 10'
 PROFILE: 1" = 4'

DRAWING No. **2015025-36**

SHEET No. **36 OF 40**

811
 Know what's below.
 Call before you dig.

REV.	DESCRIPTION	DATE	DRAWN	CHECKED
02	BID SET	2/09/2016	JKA	IVK
01	U OF M REVIEW	11/05/2015	JKA	IVK
00	PROJECT ENGINEER REVIEW	10/02/2015	JKA	IVK

CITY OF ANN ARBOR
 PUBLIC SERVICES
 301 EAST HURON STREET
 ANN ARBOR, MI 48106-6647
 ANN ARBOR 734.784.4110
 www.a2gov.org

S:\Project Management\Design\2015025 Observatory\Plan Production\2015025\NT.dwg Dwg Created: 2-Feb-16 - _g2 standard bw.stb - Plot Date: 12-Feb-16

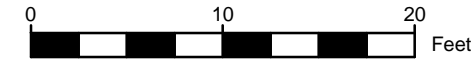
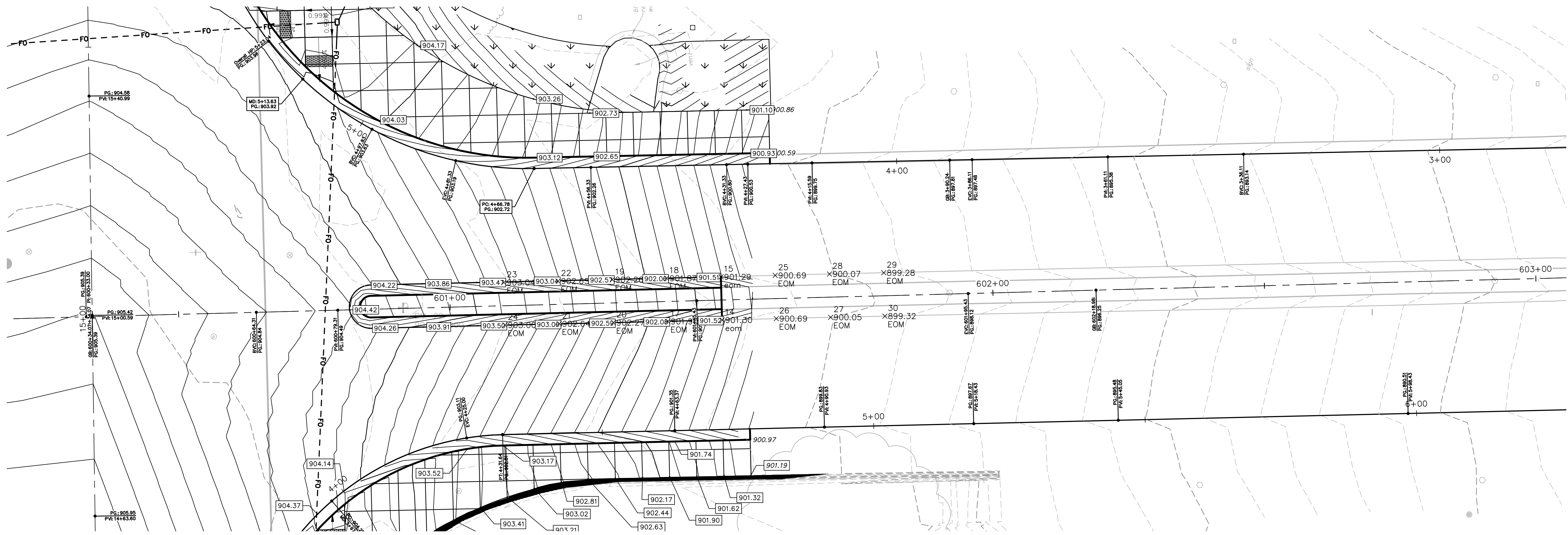

E MEDICAL

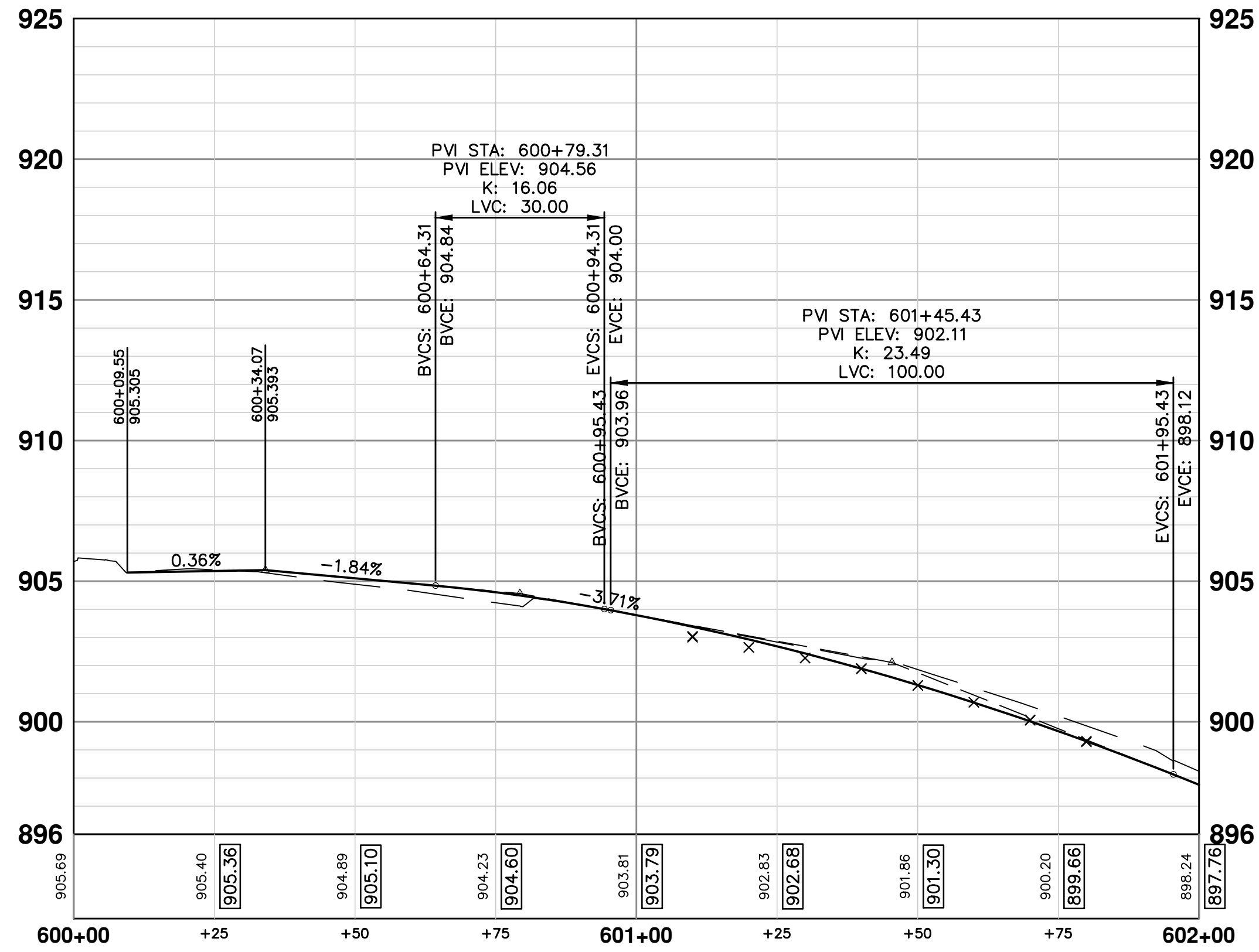

E MEDICAL

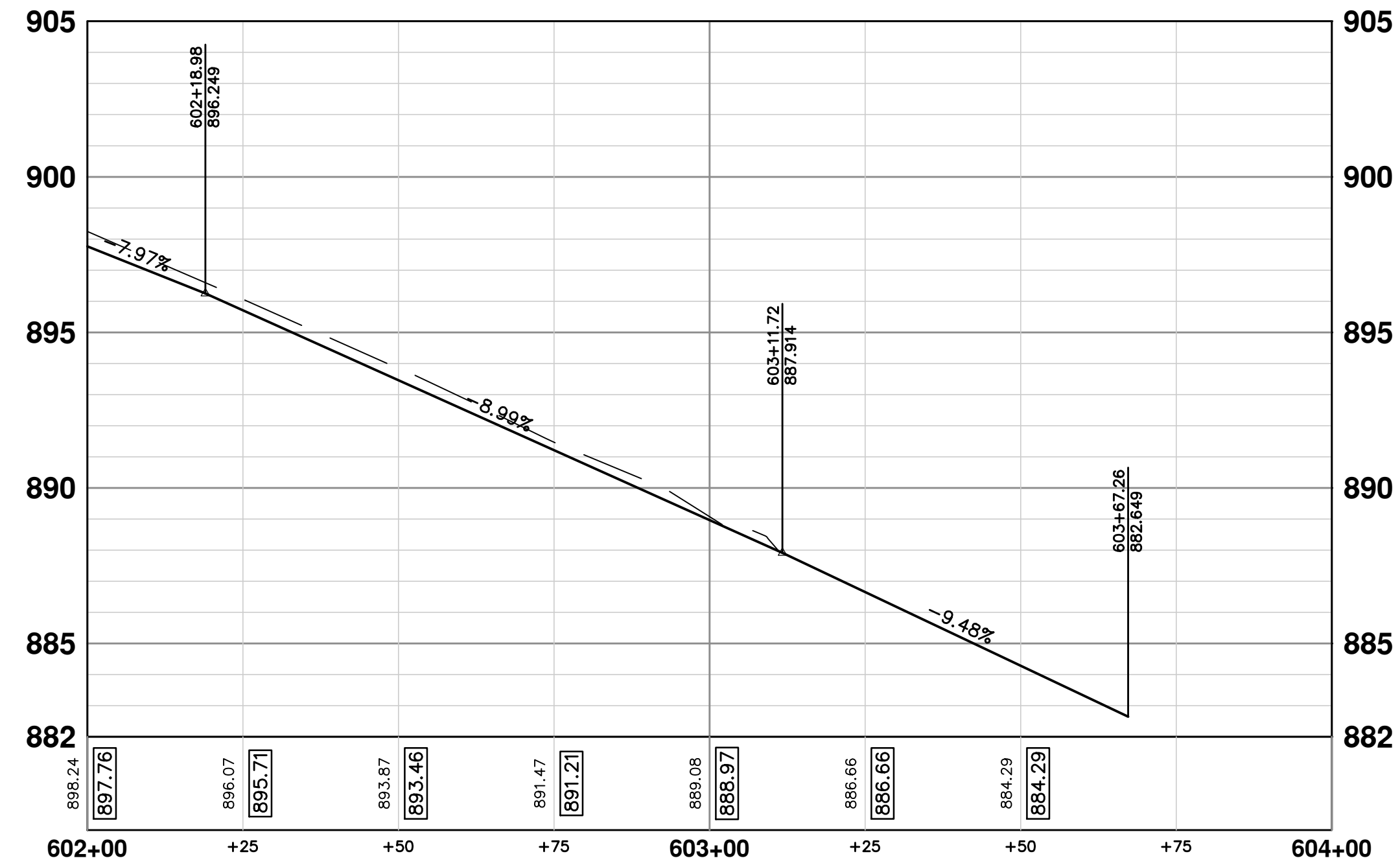

REV.	DESCRIPTION	DATE	DRAWN	CHECKED
02	BID SET	2/09/2016	JKA	IVK
01	U OF M REVIEW	11/05/2015	JKA	IVK
00	PROJECT ENGINEER REVIEW	10/02/2015	JKA	IVK

CITY OF ANN ARBOR
PUBLIC SERVICES
301 EAST HURON STREET
ANN ARBOR MI 48106-0647
www.a2gov.org



PROJECT MANAGEMENT - PUBLIC SERVICES - CITY OF ANN ARBOR
OBSERVATORY STREET IMPROVEMENT PROJECT
INTERSECTIONS
E MEDICAL CENTER DRIVE

SCALE PLAN: 1" = 10'
PROFILE: 1" = 4'
DRAWING No. 2015025-37

S:\Project Management\Design\2015025 Observatory\Plan Production\2015025PAVTRK.dwg Dwg Created: 4-Feb-16 - _a2_standard bw.stb - Plot Date: 12-Feb-16

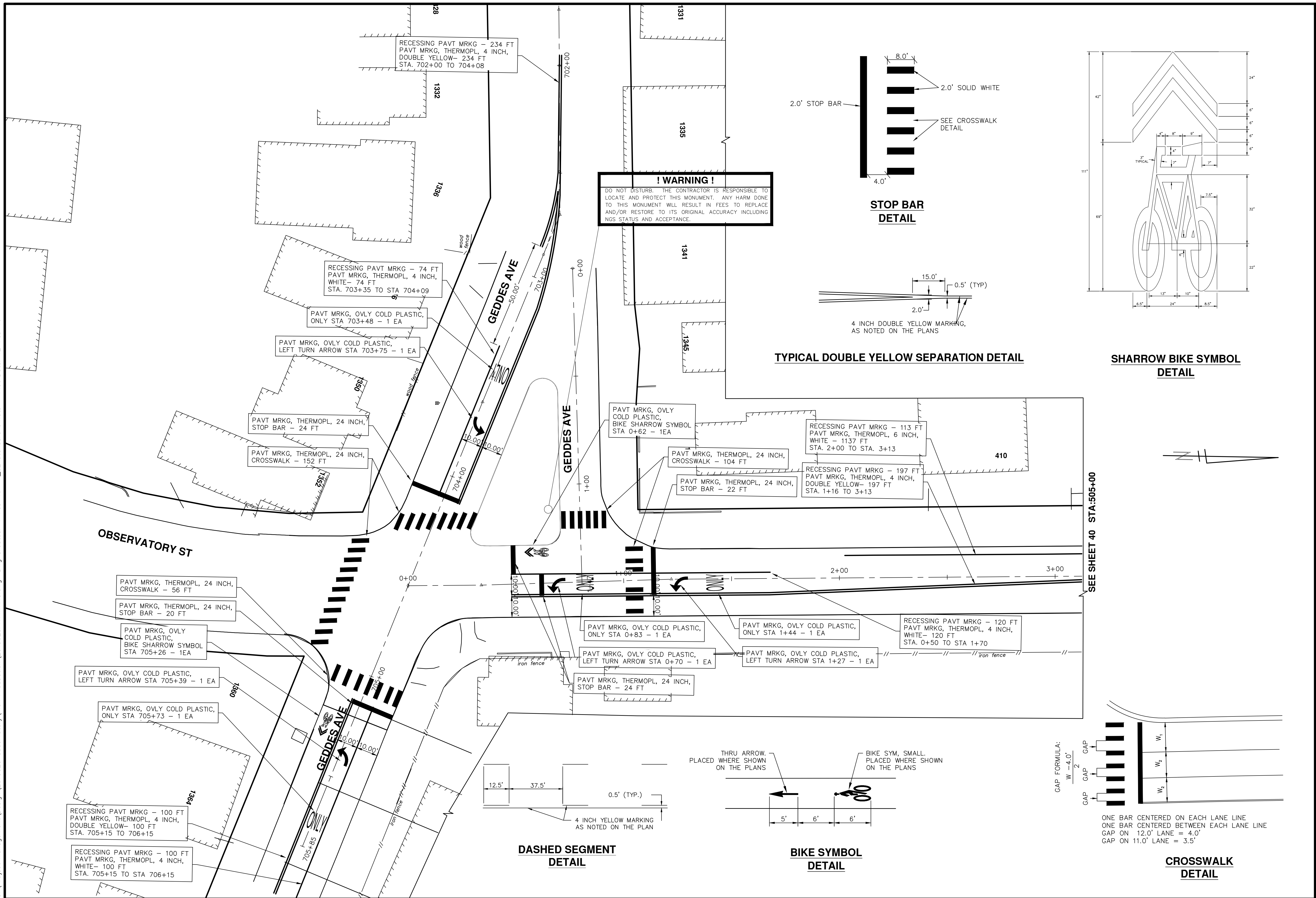

! WARNING !
DO NOT DISTURB. THE CONTRACTOR IS RESPONSIBLE TO LOCATE AND PROTECT THIS MONUMENT. ANY HARM DONE TO THIS MONUMENT WILL RESULT IN FEES TO REPLACE AND/OR RESTORE TO ITS ORIGINAL ACCURACY INCLUDING NGS STATUS AND ACCEPTANCE.

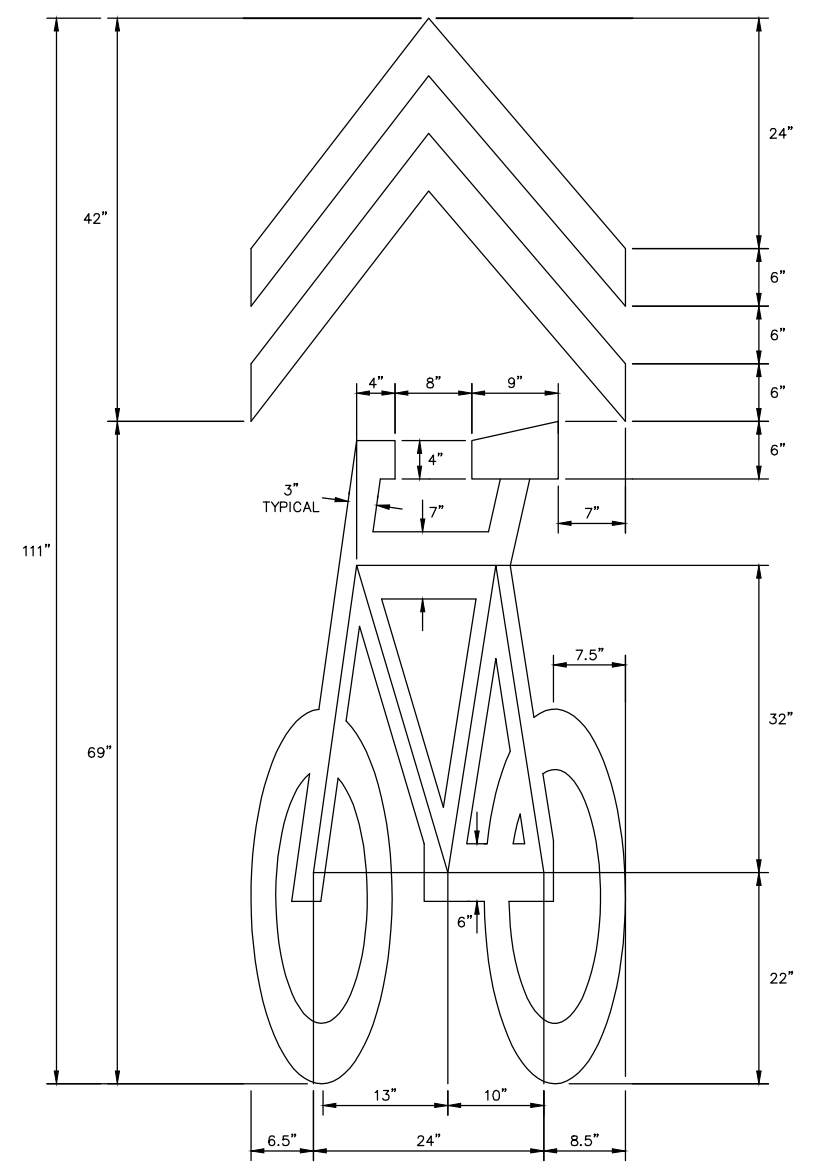
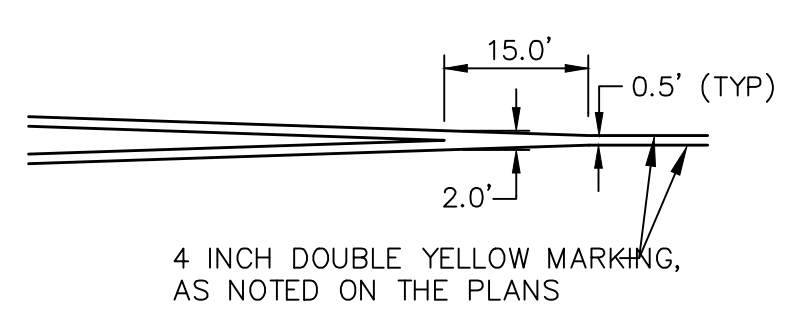
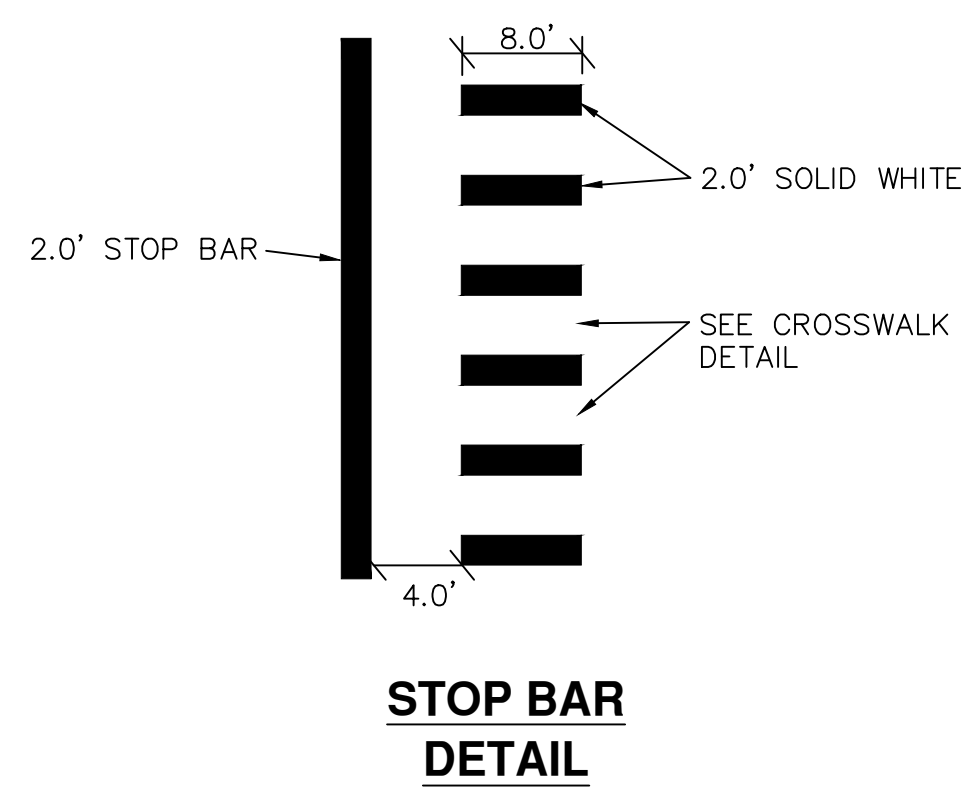

SEE SHEET 40 STA:505+00

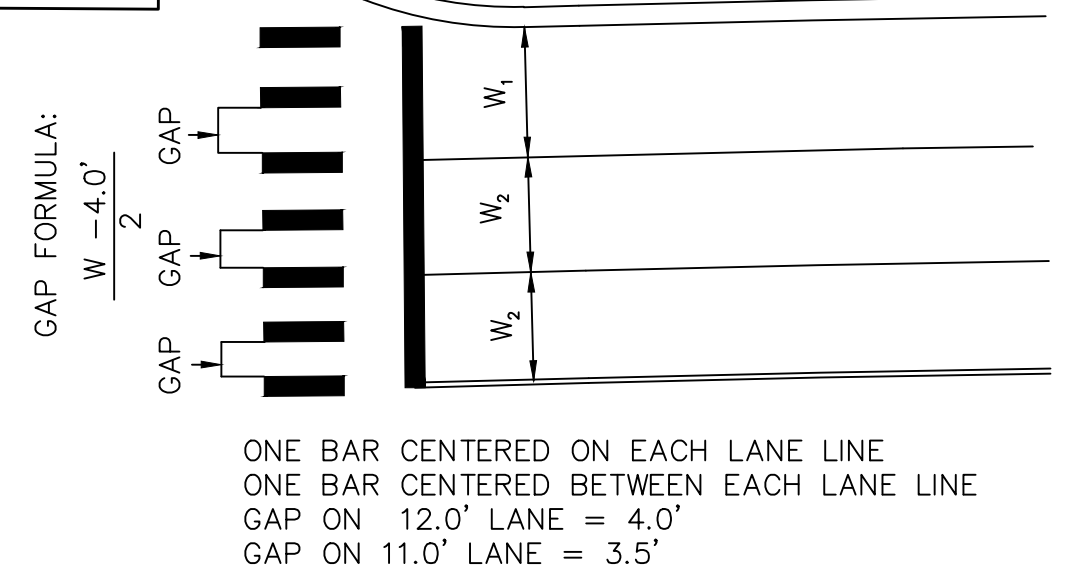
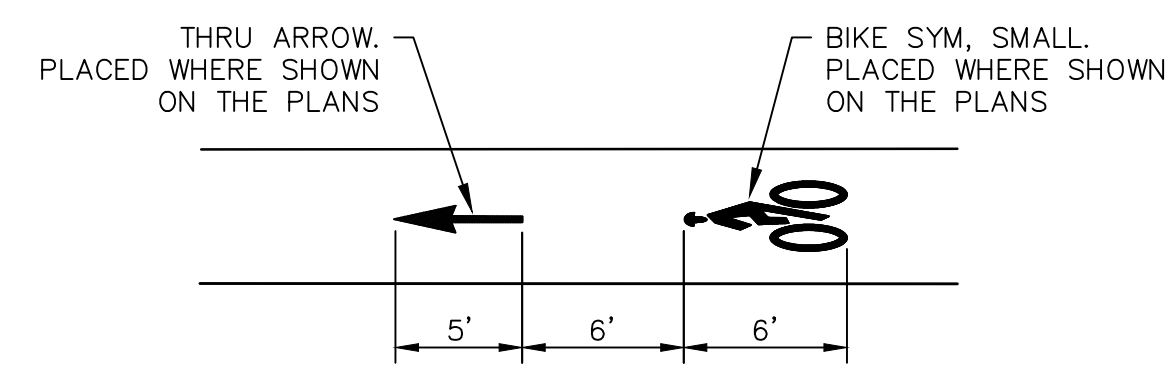
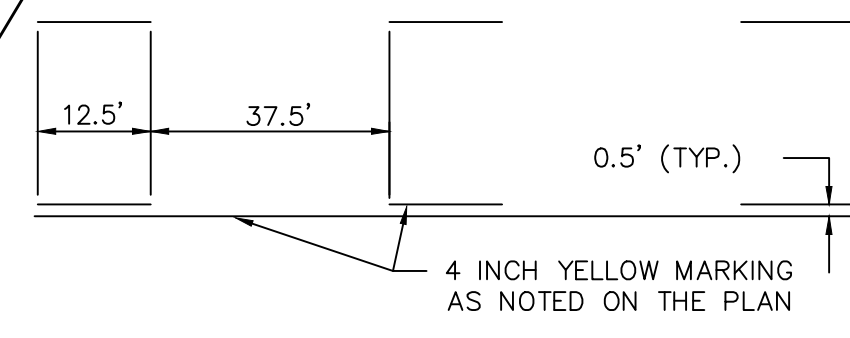

811
Know what's below. Call Before you dig.

REV.	DATE	DRAWN	CHECKED
01	11/05/2015	JKA	JKA
00	10/02/2015	JKA	JKA

CITY OF ANN ARBOR PUBLIC SERVICES
301 EAST HURON STREET
ANN ARBOR MI 48106-0667
www.a3gov.org

PROJECT MANAGEMENT - PUBLIC SERVICES - CITY OF ANN ARBOR
OBSERVATORY STREET IMPROVEMENT PROJECT

PAVEMENT MARKINGS
PAVT MRKG GEDDES

SCALE PLAN: 1" = 20'

DRAWING No. **2015025-38**

SHEET No. **38 OF 40**

PAVT MRKG GEDDES

S:\Project Management\Design\2015025 Observatory\Plan Production\2015025PAVTRKKG.dwg Dwg Created: 4-Feb-16 - a2_standard bw.stb - Plot Date: 12-Feb-16

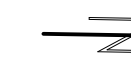
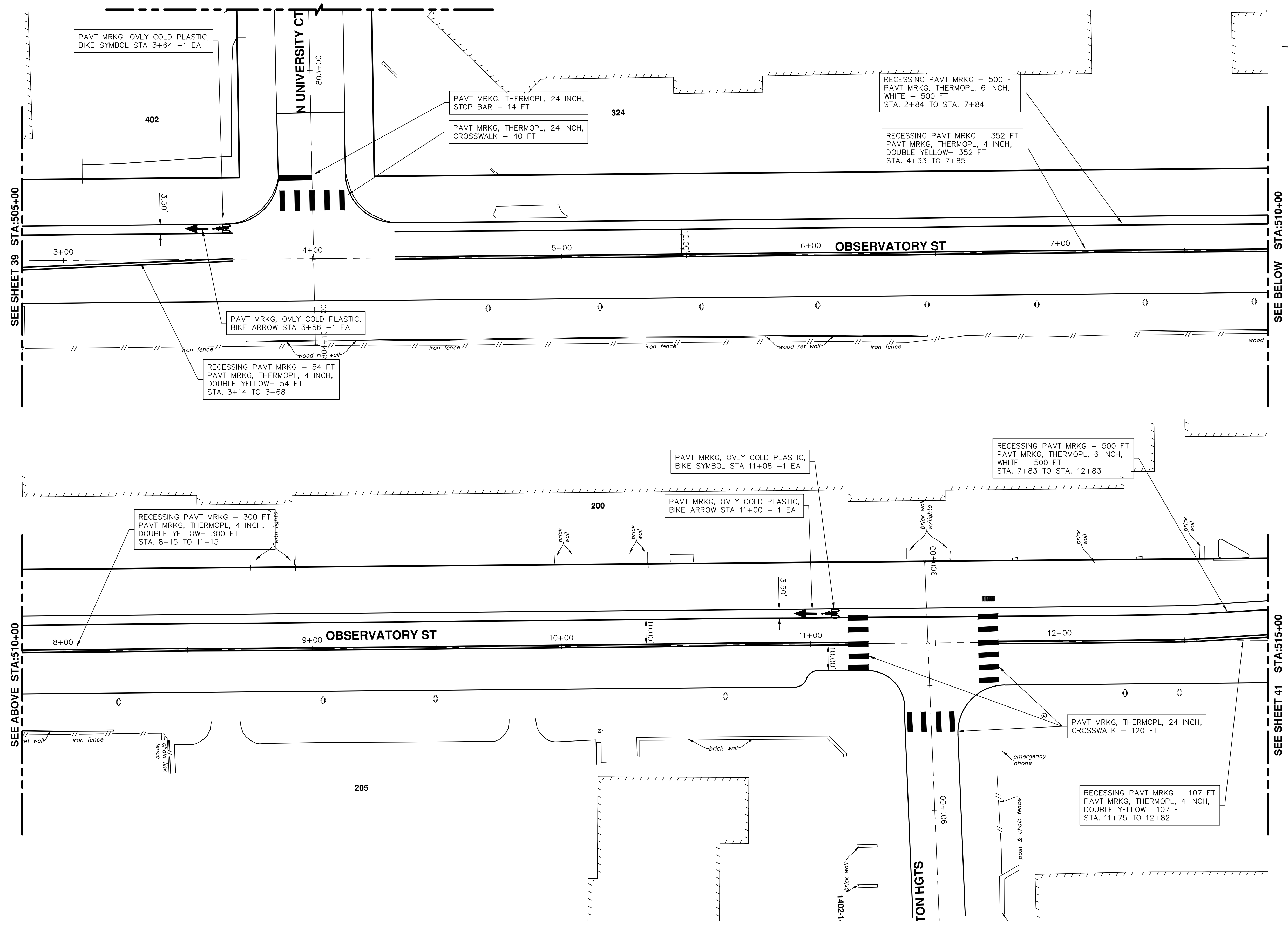

REV.	DESCRIPTION	DATE	DRAWN	CHECKED
01	U OF M REVIEW	11/05/2015	JKA	IVK
00	PROJECT ENGINEER REVIEW	10/02/2015	JKA	IVK

CITY OF ANN ARBOR
 PUBLIC SERVICE
 301 EAST HURON STREET
 ANN ARBOR, MI 48106-8647
 ANN ARBOR: 734-754-4410
 www.a2gov.org



PROJECT MANAGEMENT - PUBLIC SERVICES - CITY OF ANN ARBOR
OBSERVATORY STREET IMPROVEMENT PROJECT
 PAVEMENT MARKINGS
 PAVT MRKG OBSERVATORY 505+00 TO 515+00

SCALE PLAN: 1" = 20'
 DRAWING No. 2015025-39

S:\Project Management\Design\2015025 Observatory\Plan Production\2015025PAVTRKKG.dwg Dwg Created: 4-Feb-16 - _a2_standard bw.stb - Plot Date: 12-Feb-16

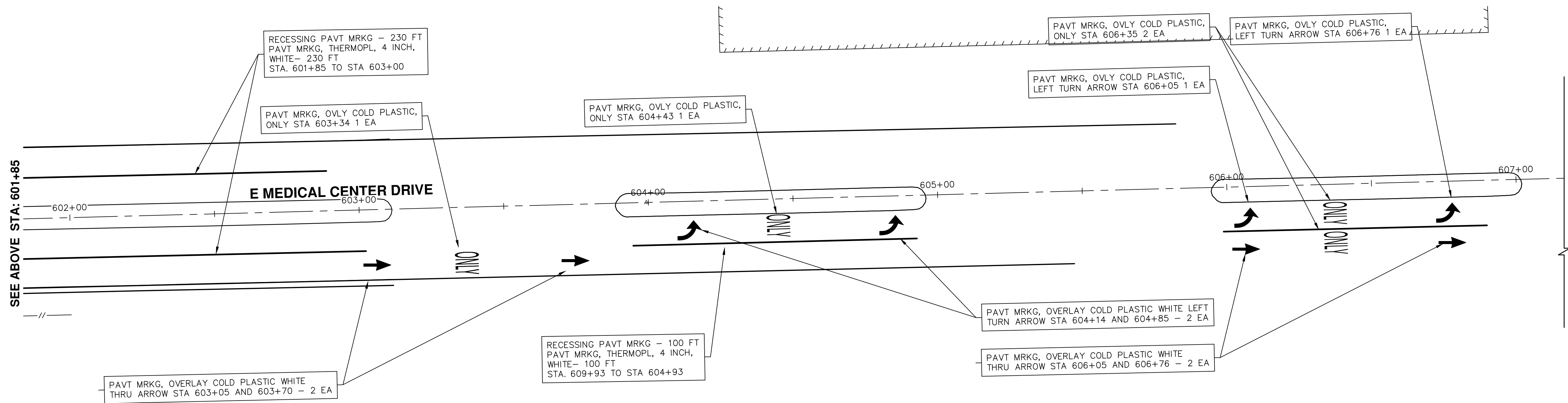
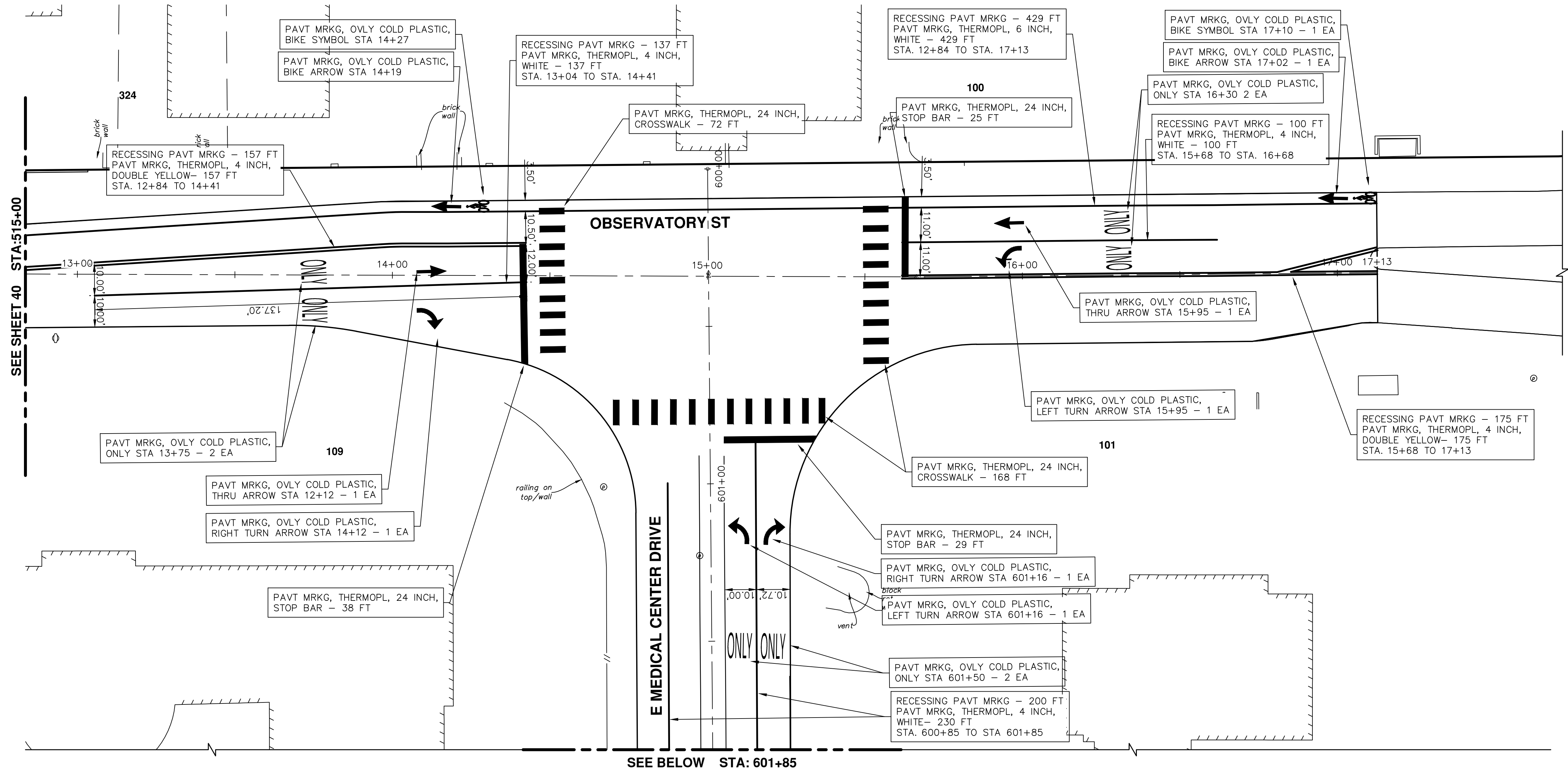

811
Know what's below.
Call before you dig.

REV.	DATE	DRAWN	CHECKED	DESCRIPTION
01	11/05/2015	JKA	JKA	U OF M REVIEW
00	10/02/2015	JKA	JKA	PROJECT ENGINEER REVIEW

CITY OF ANN ARBOR
PUBLIC SERVICES
301 EAST HURON STREET
ANN ARBOR MI 48106-8647
www.a2gov.org

CITY OF ANN ARBOR
PUBLIC SERVICES
301 EAST HURON STREET
ANN ARBOR MI 48106-8647
www.a2gov.org

PROJECT MANAGEMENT - PUBLIC SERVICES - CITY OF ANN ARBOR
OBSERVATORY STREET IMPROVEMENT PROJECT
PAVEMENT MARKINGS
PAVT MRKG OBSERVATORY 515+00 TO POE

SCALE PLAN: 1" = 20'
DRAWING No. 2015025-40
SHEET No. 40 OF 40