

ADDENDUM No. 1

ITB No. 4368

Duncan Street Improvement Project

Due: Thursday, March 5, 11:00 A.M./P.M.

The following changes, additions, and/or deletions shall be made to the Invitation to Bid for **Duncan Street Improvement Project**, ITB No. 4368, on which proposals will be received on/or before Thursday, March 5, 2015, by 11:00 A.M.

The information contained herein shall take precedence over the original documents and all previous addenda (if any), and is appended thereto. **This Addendum includes 6 page(s) and 2 drawing(s).**

Bidder is to acknowledge receipt of this Addendum No. 1, including all attachments (if any) in its Bid by so indicating on page ITB-1 of the Invitation to Bid Form. Bids submitted without acknowledgement of receipt of this addendum will be considered nonconforming.

I. CORRECTIONS/ADDITIONS/DELETIONS

Changes to the Bid documents which are outlined below are referenced to a page or Section in which they appear conspicuously. The Bidder is to take note in its review of the documents and include these changes as they may affect work or details in other areas not specifically referenced here.

- | | |
|-----------|--|
| Item # 1 | Contract Documents, Instructions to Bidders
Replace page IB-4 with the attached revised page IB-4 (ADD-1-2) |
| Item # 2 | Contract Documents, Contract
Replace pages C-1 through C-11 with the attached revised pages C-1 through C-4 (ADD-1-3 to ADD 1-6) |
| Item # 3: | Contract Plan Set
Replace plan sheets 4 and 13 with attached plan sheers.
The revised plans show changes to the Trench Detail and water main connection notes. |

Bidders are responsible for any conclusions that they may draw from the information contained in the Addendum.

The acceptability of major subcontractors will be considered in determining if a Bidder is responsible. In comparing Bids, the City will give consideration to alternate Bids for items listed in the bid forms.

Official Documents

The City of Ann Arbor shall accept no alternates to the bid documents made by the Bidder unless those alternatives are set forth in the "Alternate" section of Bid form.

The City of Ann Arbor officially distributes bid documents from the Procurement Unit or through the Michigan Intergovernmental Trade Network (MITN). Copies of the bid documents obtained from any other source are not Official copies. Addenda and other bid information will only be posted to these official distribution sites. If you obtained City of Ann Arbor Bid documents from other sources, it is recommended that you register on www.MITN.info and obtain an official Bid.

Bid Security

Each bid must be accompanied by a certified check, or Bid Bond by a surety licensed and authorized to do business within the State of Michigan, in the amount of 5% of the total of the bid price.

Withdrawal of Bids

After the time of opening, no Bid may be withdrawn for the period of 90 days, as specified in the Advertisement.

Contract Time

Time is of the essence in the performance of the work under this Contract. The available time for work under this Contract is indicated on page C-1, Article III of the Contract. If these time requirements can not be met, the Bidder must stipulate on Bid Form Section 3 - Time Alternate its schedule for performance of the work. Consideration will be given to time in evaluating bids.

Liquidated Damages

A liquidated damages clause, as given on page C-2, Article III of the Contract, provides that the Contractor shall pay the City as liquidated damages, and not as a penalty, a sum certain per day for each and every day that the Contractor may be in default of completion of the specified work, within the time(s) stated in the Contract, or written extensions.

Liquidated damages clauses, as given in the General Conditions, provide further that the City shall be entitled to impose and recover liquidated damages for breach of the obligations under Chapter 112 of the City Code.

The liquidated damages are for the non-quantifiable aspects of any of the previously identified events and do not cover actual damages that can be shown or quantified nor are they intended to preclude recovery of actual damages in addition to the recovery of liquidated damages.

CONTRACT

THIS AGREEMENT is made on the _____ day of _____, 201_, between the CITY OF ANN ARBOR, a Michigan Municipal Corporation, 301 E. Huron Street, Ann Arbor, Michigan 48104 (“City”) and _____ (“Contractor”)

..... (An individual/partnership/corporation, include state of incorporation)
(Address)

Based upon the mutual promises below, the Contractor and the City agree as follows:

ARTICLE I - Scope of Work

The Contractor agrees to furnish all of the materials, equipment and labor necessary; and to abide by all the duties and responsibilities applicable to it for the project titled _____ in accordance with the requirements and provisions of the following documents, including all written modifications incorporated into any of the documents, which are incorporated as part of this Contract:

- | | |
|--------------------------------|-------------------------|
| Human Rights Division Contract | General Conditions |
| Compliance Forms | Standard Specifications |
| Living Wage Declaration of | Detailed Specifications |
| Compliance Forms | Plans |
| (if applicable) | Addenda |
| Conflict of Interest | |
| Bid Forms | |
| Contract and Exhibits | |
| Bonds | |

ARTICLE II - Definitions

Administering Service Area/Unit means _____

Supervising Professional means City Engineer acting personally or through any assistants authorized by the Administrator/Manager of the Administering Service Area/Unit.

Project means _____

ARTICLE III - Time of Completion

- (A) The work to be completed under this Contract shall begin immediately on the date specified in the Notice to Proceed issued by the City.
- (B) The entire work for this Contract shall be completed within scheduling requirements as specified in the Detailed Specifications.
- (C) Failure to complete all the work within the time specified above, including any extension granted in writing by the Supervising Professional, shall obligate the Contractor to pay the City, as liquidated damages and not as a penalty, an amount specified in Detailed Specification for Project Schedule and Payment shown on Page DS-1. If any liquidated damages are unpaid by the Contractor,

the City shall be entitled to deduct these unpaid liquidated damages from the monies due the Contractor.

As an independent requirement, where the Detailed Specifications identify certain portions of the work to be completed within a shorter period of time and the Contractor fails to complete each portion within the shorter period specified for each portion, including any extension granted in writing by the Project Supervisor, the City is entitled to deduct from the monies due the Contractor, as liquidated damages and not as a penalty, the amount identified in the Detailed Specifications for each portion of the work not timely completed for each calendar day of delay in completion of each portion of the work.

The liquidated damages are for the non-quantifiable aspects of any of the previously identified events and do not cover actual damages that can be shown or quantified nor are they intended to preclude recovery of actual damages in addition to the recovery of liquidated damages.

Liquidated damages under this section are in addition to any liquidated damages due under Section 5 of the General Conditions.

ARTICLE IV - The Contract Sum

- (A) The City shall pay to the Contractor for the performance of the Contract, the unit prices as given in the Bid Forms for the estimated total of:

_____ Dollars (\$_____)

- (B) The amount paid shall be equitably adjusted to cover changes in the work ordered by the Supervising Professional but not required by the contract documents.

ARTICLE V - Assignment

This Contract may not be assigned or subcontracted without the written consent of the City.

ARTICLE VI - Choice of Law

This Contract shall be construed, governed, and enforced in accordance with the laws of the State of Michigan. By executing this agreement, the Contractor and the City agree to venue in a court of appropriate jurisdiction sitting within Washtenaw County for purposes of any action arising under this Contract. The parties stipulate that the venue referenced in this Contract is for convenience and waive any claim of non-convenience.

Whenever possible, each provision of the contract will be interpreted in a manner as to be effective and valid under applicable law. The prohibition or invalidity, under applicable law, of any provision will not invalidate the remainder of the contract.

ARTICLE VII - Relationship of the Parties

The parties of the Contract agree that it is not a contract of employment but is a contract to accomplish a specific result. Contractor is an independent contractor performing services for the City. Nothing contained in this Contract shall be deemed to constitute any other relationship between the City and the Contractor.

Contractor certifies that it has no personal or financial interest in the project other than the compensation it is to receive under the Contract. Contractor certifies that it is not, and shall not become, overdue or in default to the City for any contract, debt, or any other obligation to the City including real or personal property taxes. City shall have the right to set off any such debt against compensation awarded for services under this agreement.

ARTICLE VIII - Notice

All notices given under this contract shall be in writing, and shall be by personal delivery or by certified mail with return receipt requested to the parties at their respective addresses as specified in the contract documents or other address the Contractor may specify in writing.

ARTICLE IX - Indemnification

To the fullest extent permitted by law, Contractor shall indemnify, defend and hold harmless the City, its officers, employees and agents harmless from all suits, claims, judgments and expenses including attorney's fees resulting or alleged to result, in whole or in part, from any act or omission, which is in any way connected or associated with this contract, by the Contractor or anyone acting on the Contractor's behalf under this contract. Contractor shall not be responsible to indemnify the City for losses or damages caused by or resulting from the City's sole negligence.

ARTICLE X - Entire Agreement

This Contract represents the entire understanding between the City and the Contractor and it supersedes all prior representations or agreements whether written or oral. Neither party has relied on any prior representations in entering into this Contract. This Contract may be altered, amended or modified only by written amendment signed by the City and the Contractor.

FOR CONTRACTOR

By _____

Its: _____

FOR THE CITY OF ANN ARBOR

By _____
Christopher Taylor, Mayor

By _____
Jacqueline Beaudry, City Clerk

Approved as to substance

By _____
Steven D. Powers, City Administrator

By _____
Craig Hupy
Public Services Area Administrator

Approved as to form and content

Stephen K. Postema, City Attorney

S:\Project Management\Design\2013027 Duncan St\Plan Production\Primary\2013027Det.dwg Dwg Created: 28-Aug-14 - a2 standard bw.stb - Plot Date: 27-Feb-15



00	ADDENDUM #1	DESCRIPTION	REV.
02-27-15	DATE	DRAWN	CHECKED
		IVK	

CITY OF ANN ARBOR
PUBLIC SERVICES
301 EAST HURON STREET
ANN ARBOR MI 48106-0647
www.a2gov.org

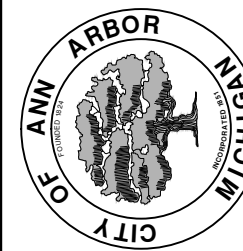

PROJECT MANAGEMENT - PUBLIC SERVICES - CITY OF ANN ARBOR
DUNCAN STREET IMPROVEMENTS
ROAD SECTION, TRENCH DETAIL, INLET DETAIL

SHEET No. 4 OF 17
SCALE: NTS
DRAWING No. 2013027-4

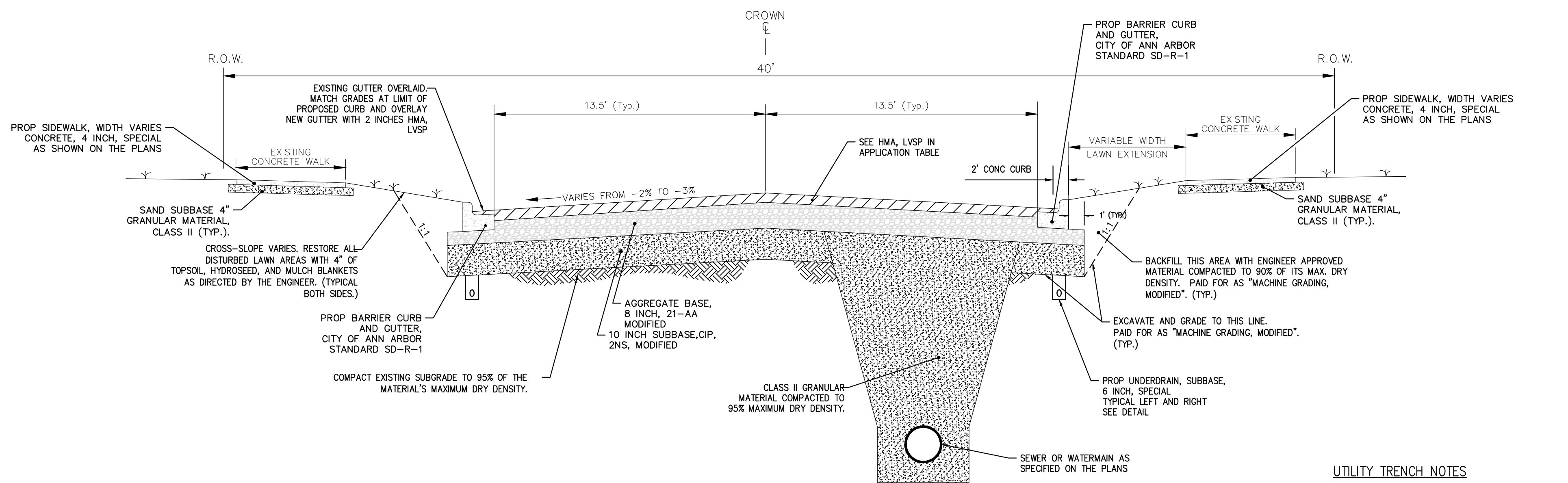

DUNCAN STREET PROPOSED TYPICAL CROSS SECTION
N.T.S.

HMA MIX	RATE OF APPLICATION	THICKNESS (INCHES)	AWI (MIN.)	BINDER	LOCATION/NOTES
LVSP	220 LB/SYD	2.0	260 (TOP)	PG 58-28	TOP COURSE
LVSP	220 LB/SYD	2.0	260 (TOP)	PG 58-28	LEVELING COURSE
Bond Coat SS-1h	0.05 GAL/SYD	-	-	-	INCLUDE IN COST OF HMA ITEM

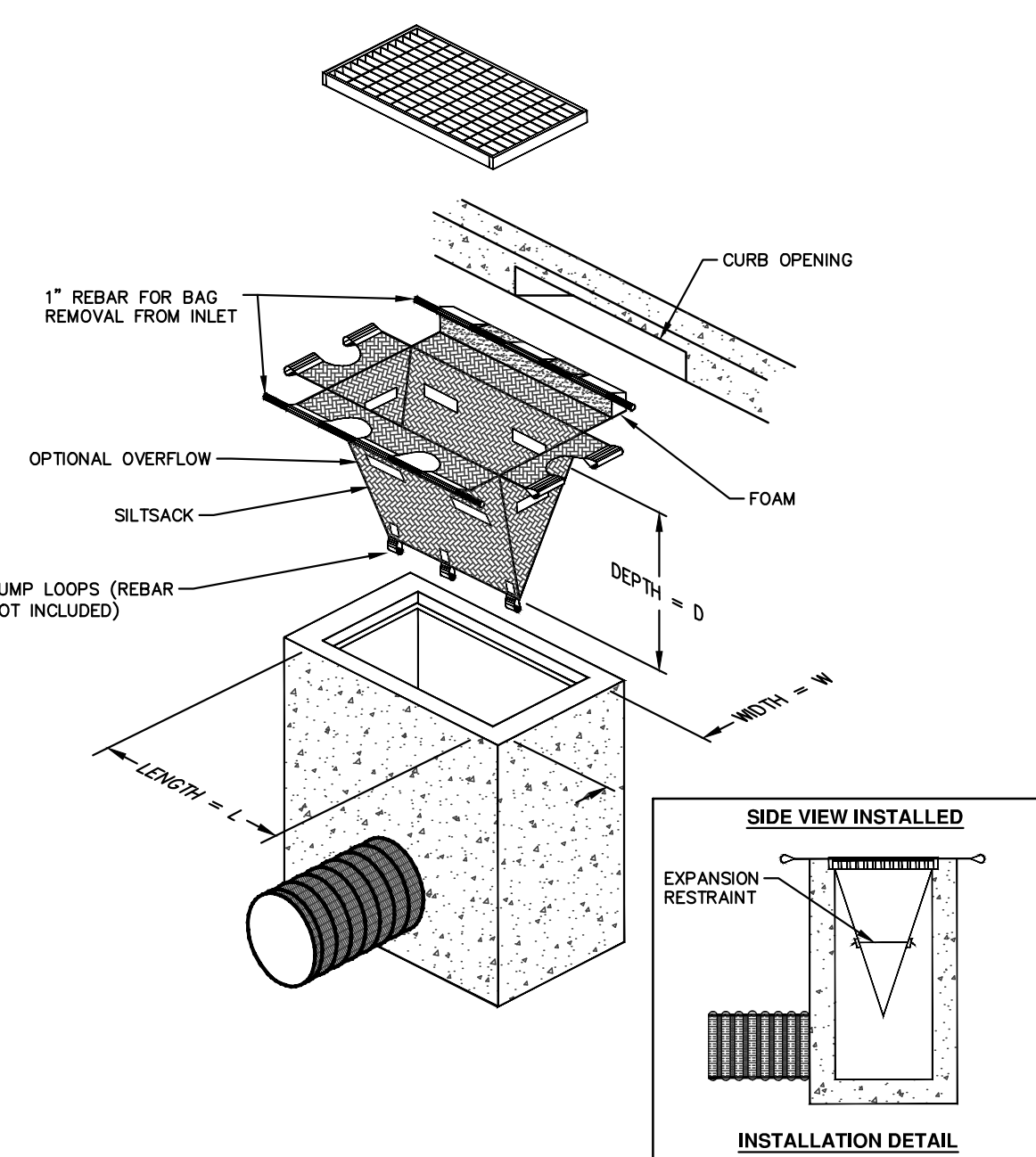

SILTSACK DETAIL

NOTE: THE SILTSACK WILL BE MANUFACTURED FROM A WOVEN POLYPROPYLENE FABRIC THAT MEETS OR EXCEEDS THE FOLLOWING SPECIFICATIONS.

REGULAR FLOW SILTSACK

(FOR AREAS OF LOW TO MODERATE PRECIPITATION AND RUN-OFF)

PROPERTIES	REQUIRED VALUE	TEST METHOD
GRAB TENSILE STRENGTH	ASTM D-4632	300 LBS
GRAB TENSILE ELONGATION	ASTM D-4632	20%
PUNCTURE	ASTM D-4633	120 LBS
MULLEN BURST	ASTM D-3786	800 PSI
TRAPEZOID TEAR	ASTM D-4533	120 LBS
UV RESISTANCE	ASTM D-4355	80%
APPARENT OPENING SIZE	ASTM D-4751	40 US SIEVE
FLOW RATE	ASTM D-4491	40 GAL/MIN/SQ FT
PERMITTIVITY	ASTM D-4491	0.55 SEC -1

HI-FLOW SILTSACK

(FOR AREAS OF MODERATE TO HEAVY PRECIPITATION AND RUN-OFF)

PROPERTIES	REQUIRED VALUE	TEST METHOD
GRAB TENSILE STRENGTH	ASTM D-4632	265 LBS
GRAB TENSILE ELONGATION	ASTM D-4632	20%
PUNCTURE	ASTM D-4633	135 LBS
MULLEN BURST	ASTM D-3786	420 PSI
TRAPEZOID TEAR	ASTM D-4533	45 LBS
UV RESISTANCE	ASTM D-4355	90%
APPARENT OPENING SIZE	ASTM D-4751	20 US SIEVE
FLOW RATE	ASTM D-4491	200 GAL/MIN/SQ FT
PERMITTIVITY	ASTM D-4491	1.5 SEC-1

OIL-ABSORBANT SILTSACK

(FOR AREAS WHERE THERE IS A CONCERN FOR OIL RUN-OFF OR SPILLS)

IT IS THE INTENT OF THE PLANS AND SPECIFICATIONS THAT THE CONTRACTOR INSTALL THE REBAR AS SHOWN IN THIS DETAIL TO PROVIDE A FULLY FUNCTIONING UNIT. ALL COSTS ASSOCIATED WITH FURNISHING, CLEANING AS MANY TIMES AS REQUIRED, DISPOSAL OF SEDIMENT, AND REMOVING THE INLET FILTER WHEN NO LONGER NEEDED IS INCLUDED IN THE ITEM OF WORK AND WILL NOT BE PAID FOR SEPARATELY.

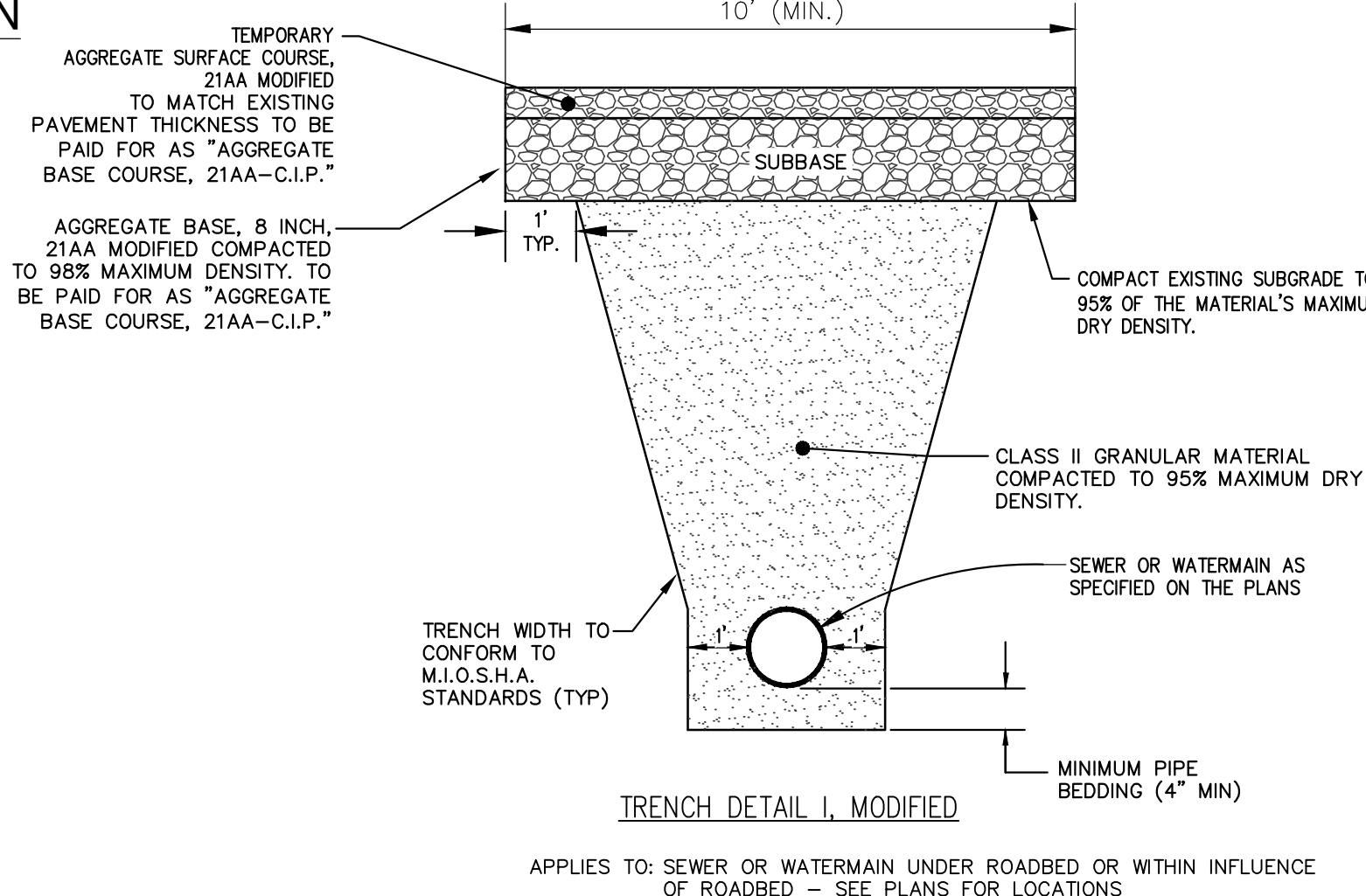

TRENCH DETAIL FOR UNDERDRAIN (UNDER HMA PAVEMENT)

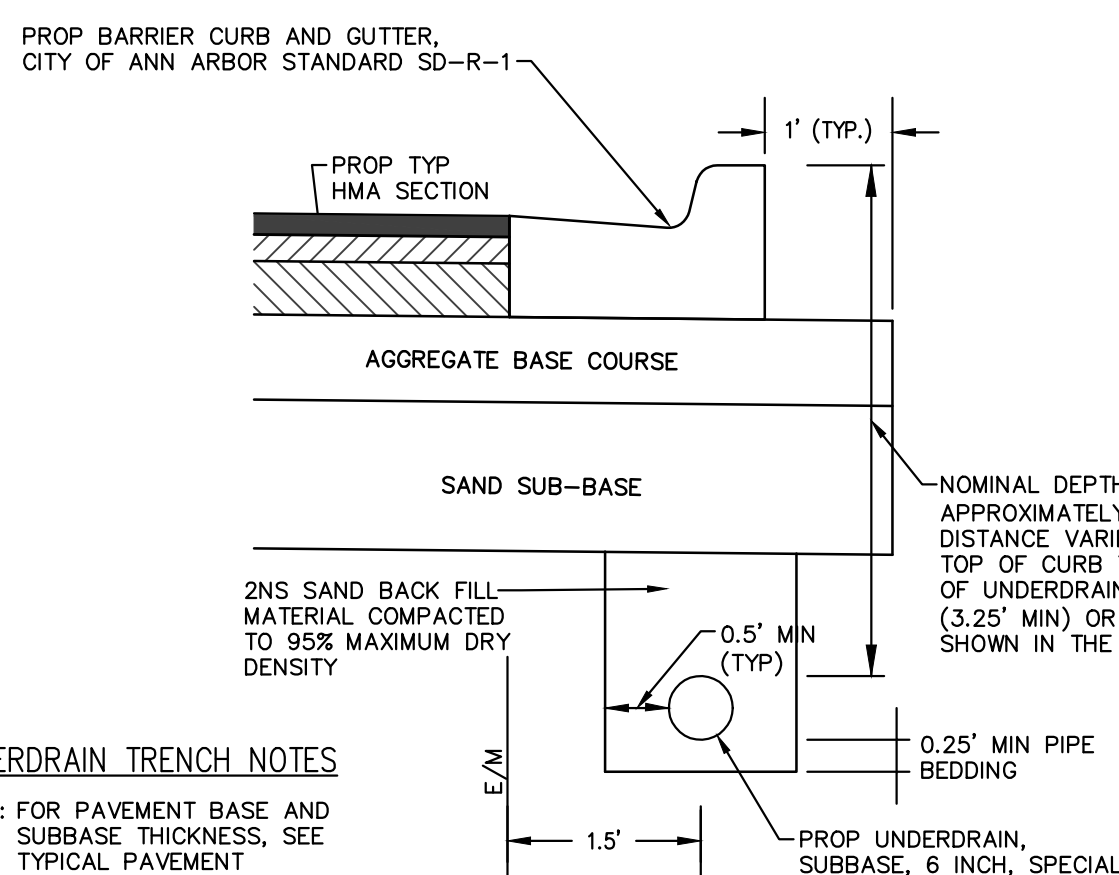

UNDERDRAIN TRENCH NOTES

NOTE: FOR PAVEMENT BASE AND SUBBASE THICKNESS, SEE TYPICAL PAVEMENT CROSS-SECTION(S)

NOTE: TRENCH DETAILS SHOW TYPE OF BACKFILL AND SURFACE RESTORATION ONLY

NOTE: ALL TRENCHING TO CONFORM TO ALL APPLICABLE M.I.O.S.H.A. STANDARDS

BASED ON CITY OF ANN ARBOR STANDARD SD-TD-10
APPLIES TO: HMA PAVEMENT - SEE PLANS FOR LOCATIONS

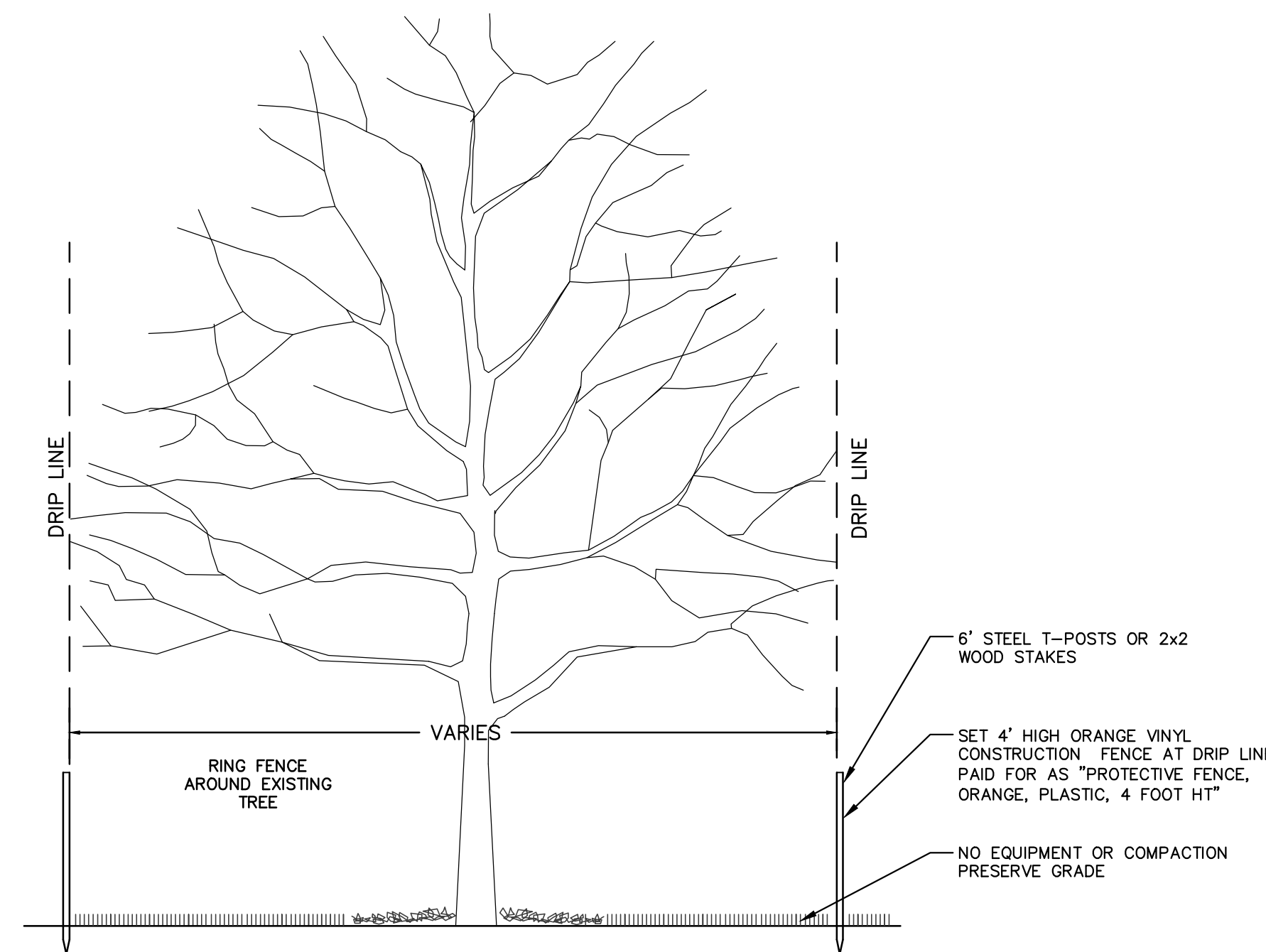

TREE PROTECTION DETAIL

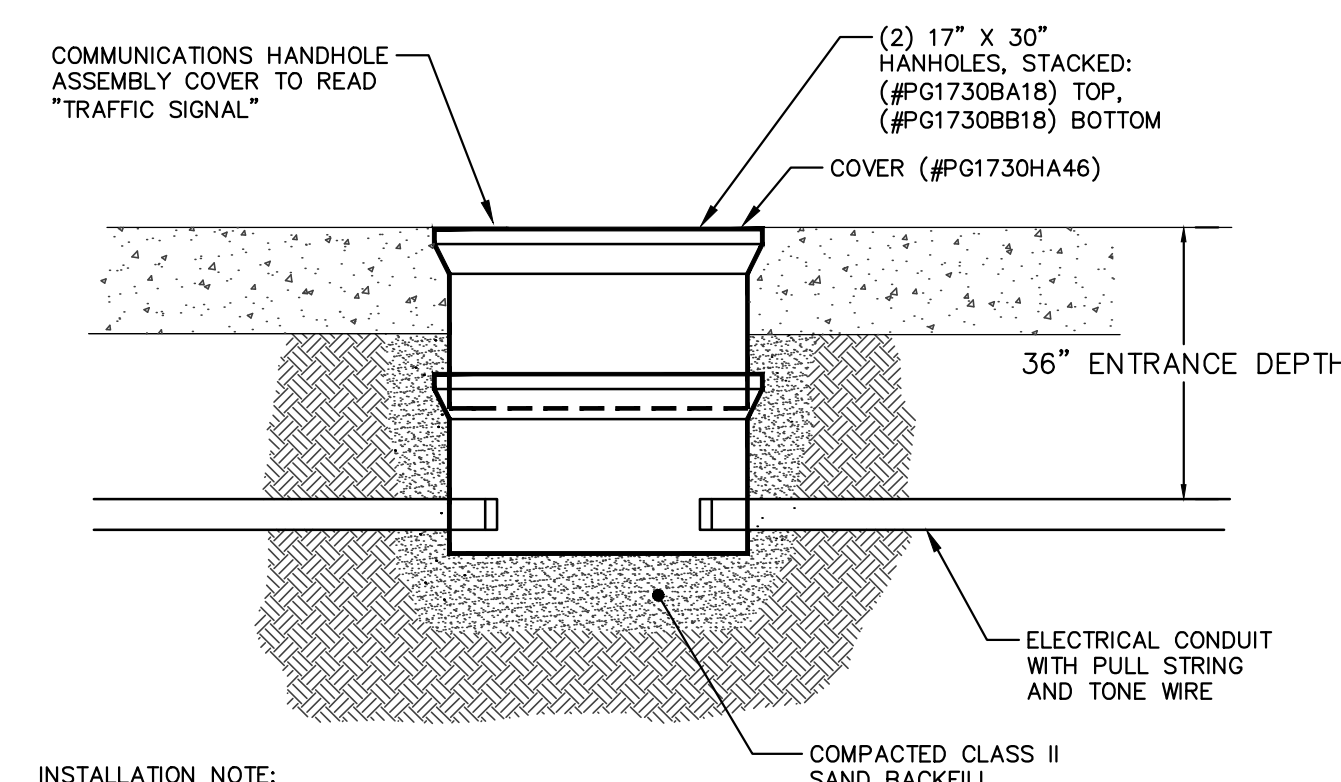

COMMUNICATIONS HANDHOLE ASSEMBLY

INSTALLATION NOTE:
THE CONDUIT SHALL BE LOWERED TO A MINIMUM ENTRANCE DEPTH OF 36" BELOW TOP OF THE HAND HOLE OVER A DISTANCE OF 10' ON EACH SIDE OF THE HANDHOLE ASSEMBLY

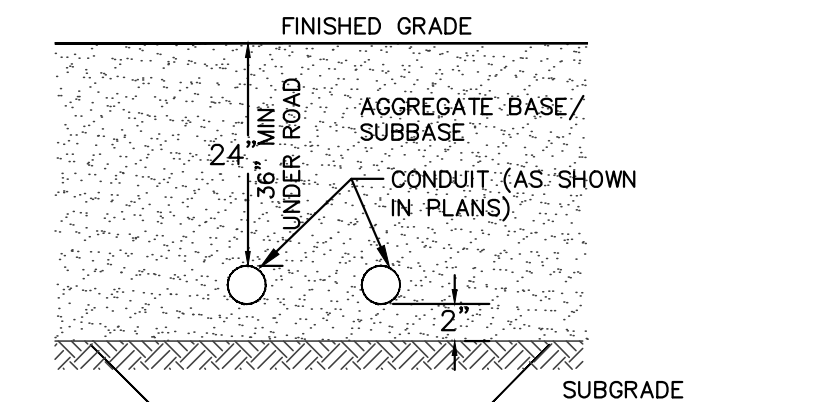

CONDUIT PLACEMENT DETAIL

MAY REQUIRE UNDERCUTTING SUBGRADE TO MAINTAIN MINIMUM DEPTH AND 2" BEDDING. BACKFILL WITH MDOT, CL II GRANULAR MATERIAL COMPACTED TO 95% MAXIMUM DRY DENSITY. THIS WORK SHALL BE INCLUDED IN COST OF CONDUIT IF REQUIRED AND WILL NOT BE PAID FOR SEPARATELY.

S:\Project Management\Design\2013027 Duncon St\Source Drawings\Pipe Networks\2013027PNWtr.dwg Dwg Created: 8-Apr-14 - _a2_standard bw.stb - Plot Date: 27-Feb-15

SEE SHEET 12
STA:16+25

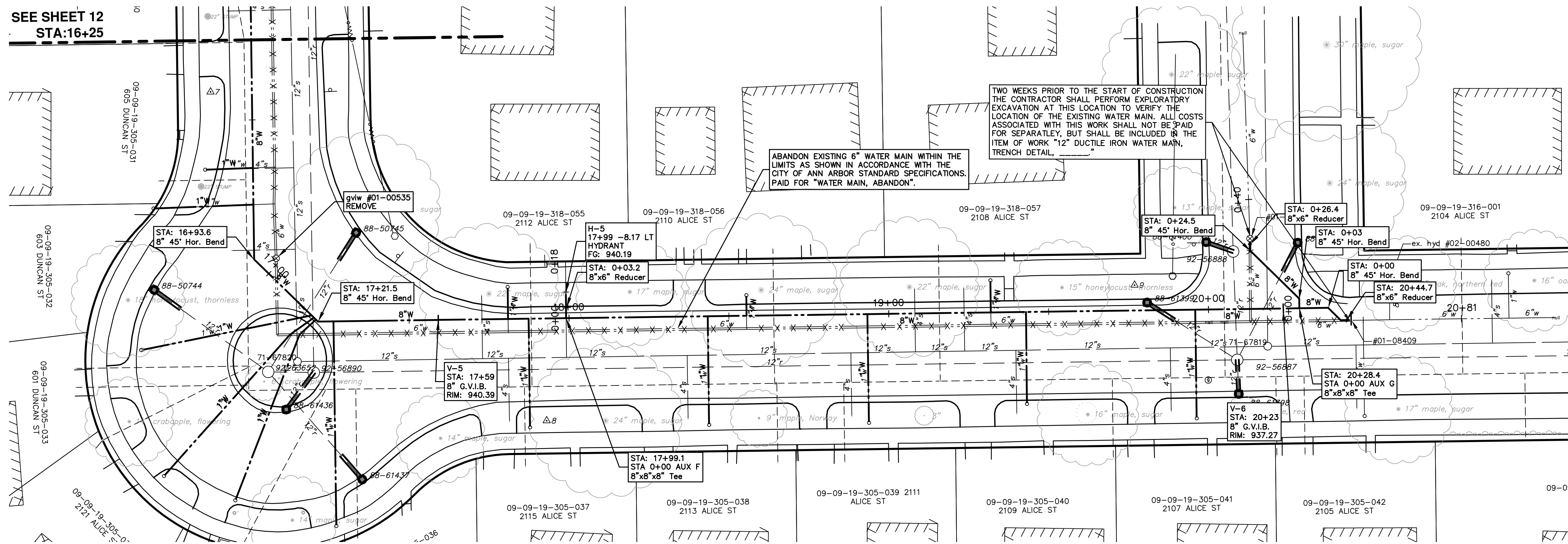

WATER MAIN STRUCTURE TABLE				
STRUCTURE	TYPE	STATION	RIM	DEPTH
H-5	HYDRANT	0+08	940.19	6.00
V-6	8" G.V.I.B.	20+23	937.27	7.84

EX WATER MAIN STRUCTURE TABLE				
STRUCTURE	TYPE	STATION	RIM	DEPTH
gviw #01-00535	REMOVE	16+76	940.96	6.04
#01-00264	gviw #01-00264	19+84	937.69	6.17
#01-08409	gviw #01-08409	20+16	936.34	6.04

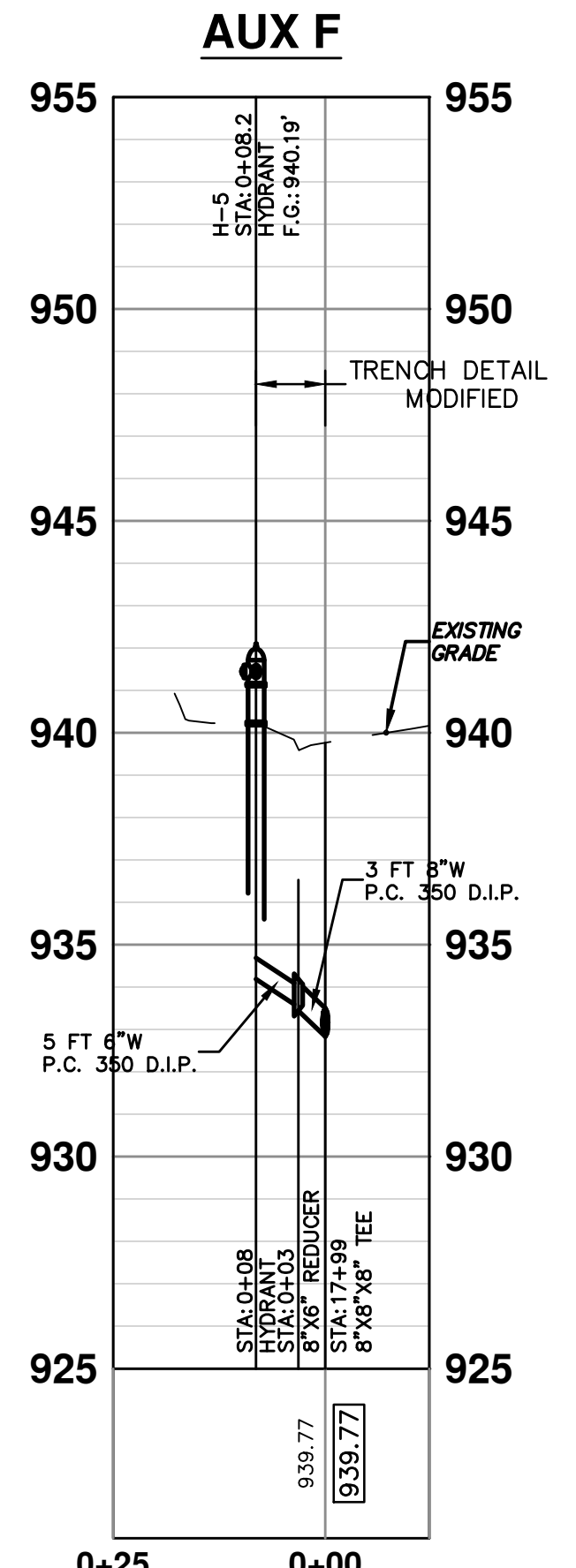
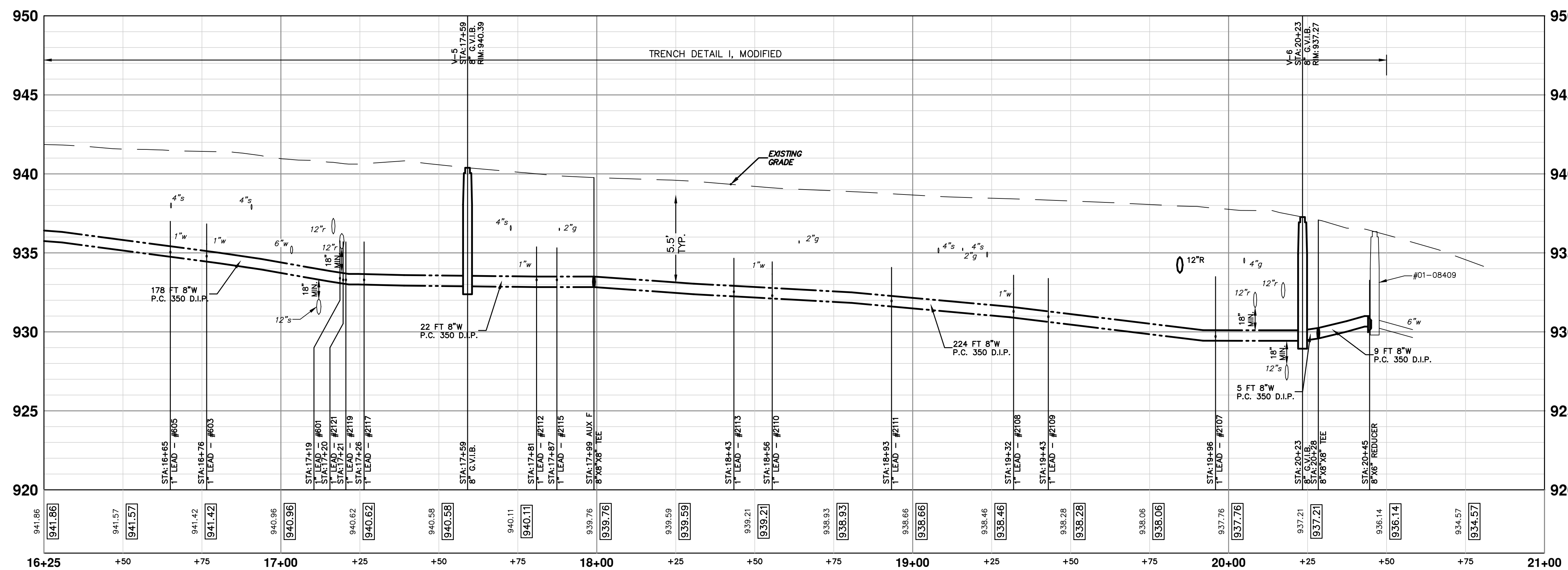



Know what's below.
Call Before you dig.

NO.	DATE	DRAWN	CHECKED

CITY OF ANN ARBOR
PUBLIC SERVICES
301 EAST HURON STREET
ANN ARBOR, MI 48106-1667
www.a2gov.org



PROJECT MANAGEMENT - PUBLIC SERVICES - CITY OF ANN ARBOR
DUNCAN STREET IMPROVEMENTS
WATER MAIN PLAN & PROFILE
WATER - STA. 16+00 TO 21+00

SCALE PLAN: 1"=20'
PROFILE: 1"=4'

DRAWING NO. 2013027-13
SHEET No. 13 OF 17