

CITY OF ANN ARBOR
REQUEST FOR PROPOSAL



Project Management Services Unit
East Huron Street (Business I-94) Sewer Lining Project

RFP No. 935

Proposal Due Date: Wednesday, December 2, 2015
On or Before 2:00 P.M. (Local Time)

Public Services Area/Project Management

Issued By:
City of Ann Arbor
Procurement Unit
City Hall, 301 East Huron Street
Ann Arbor, Michigan 48107-8647

TABLE OF CONTENTS

<u>Section</u>	<u>Page</u>
Table of Contents	i
SECTION I	
General Information	1-7
SECTION II	
Background and Scope of Work	8 - 14
SECTION III	
Minimum Information Required	15 - 17
SECTION IV	18 -
Attachment A – Sample Agreement	
Attachment B – Legal Status of Bidder	
Attachment C – Prevailing Wage Declaration of Compliance	
Attachment D – Living Wage Declaration of Compliance and Poster	
Attachment E – Vendor Conflict of Interest Disclosure Form	
Attachment F – Non-Discrimination Declaration of Compliance and Poster	
Attachment G – General Conditions	
Attachment H – Offeror’s Qualifications Form	
Attachment I – Past Involvement with Similar Projects Form	
Attachment J – Fee Proposal Form	
Attachment K - Figure 1: Site Plan	
Attachment L - Figure 2: Minimum Traffic Control Requirement	

**SECTION I
GENERAL INFORMATION**

A. OBJECTIVE

The purpose of this Request for Proposal (RFP) is to select a Contractor to perform the sanitary sewer repair work as part of the: “East Huron Street (Business I-94) Sewer Lining Project.”

B. QUESTIONS ABOUT AND CLARIFICATIONS OF THE RFP

All questions regarding this RFP shall be submitted via email. Emailed questions and inquiries will be accepted from any and all prospective respondents in accordance with the terms and conditions of this RFP.

All questions shall be submitted on or before 3:00 P.M. (Local Time), Thursday, November 19, 2015 and should be addressed as follows:

Scope of Work/Proposal Content questions emailed to Igor Koltzar, P.E. at ikotlyar@a2gov.org

RFP Process and Compliance questions to Colin Spencer at cspencer@a2gov.org

Should any prospective Respondent be in doubt as to the true meaning of any portion of this Request for Proposal, or should the Respondent find any ambiguity, inconsistency, or omission therein, the Respondent shall make a written request for an official interpretation or correction. Such requests must be received via email by ikotlyar@a2gov.org on or before Thursday, November 19, 2015 by 3:00 P.M. (Local Time).

C. PRE-PROPOSAL MEETING

A pre-proposal meeting will be held for this project on Tuesday November 17, 2015 at 2:00 P.M. at 5th Floor Conference Room, Ann Arbor City Hall. Interested Contractors are strongly encouraged to attend the meeting.

D. ADDENDUM

All interpretation or correction, as well as any additional RFP provisions that the City may decide to include, will be made only as an official addendum that will be posted to a2gov.org and MITN.info and it shall be the Respondent’s responsibility to ensure they have received all addenda before submitting a Proposal. Any addendum issued by the City shall become part of the RFP and will be incorporated in the Proposal.

To avoid any miscommunications, each Respondent must acknowledge in its proposal, all addenda which it has received, but the failure of a Respondent to receive or acknowledge receipt of any addenda shall not relieve the Respondent of the responsibility for complying with the terms thereof.

The City will not be bound by oral responses to inquiries or written responses other than official written addenda.

E. PROPOSAL FORMAT

To be considered, each Contractor must submit a response to this RFP using the format provided in Section III. No other distribution of proposals is to be made by the Respondent. The proposal must be signed in ink by an official authorized to bind the Respondent to its provisions. Each proposal must remain valid for at least ninety (90) days from the due date of this RFP.

Proposals should be prepared simply and economically providing a straightforward, concise description of the Respondent's ability to meet the requirements of the RFP. Each total submittal should not be more than 50 sheets (100 sides), not including required attachments. No erasures are permitted. Mistakes may be crossed out and corrected and must be initialed in ink by the person signing the proposal.

Each person signing the Proposal is required to certify that he/she is the person in the Respondent's firm/organization responsible for the decision as to the fees being offered in the Proposal and has not and will not participated in any action contrary to the terms of this provision.

F. SELECTION CRITERIA

Responses to this RFP will be evaluated using a point system as shown in Section III.

At the initial evaluation, the fee proposals will not be reviewed. After initial evaluation the City will determine top respondents, and open only those fee proposals. The City will then determine which, if any, firms will be interviewed. During the interviews, the selected firms will be given the opportunity to discuss their proposal, qualifications, past experience, and their fee proposal in more detail. If the City chooses to interview any respondents, the interviews will be held in December of 2015.

All Proposals submitted may be subject to clarifications and further negotiation. All agreements resulting from negotiations that differ from what is represented within the RFP or in the Respondent's response shall be documented and included as part of the final contract.

G. SEALED PROPOSAL SUBMISSION

All Proposals are due and must be delivered to the City Procurement Unit c/o Customer Service on, or before, **Wednesday, December 2, 2015 by 2:00 p.m.** (local time). Proposals submitted late or via oral, telephonic, telegraphic, electronic mail or facsimile **will not** be considered or accepted.

Each Respondent **must submit in a sealed envelope one (1) original Proposal, five (5) additional Proposal copies, and two (2) copies of the Fee Proposal in a separate sealed envelope marked fee proposal contained within respondent's sealed proposal.** Proposals submitted must be clearly marked: **RFP No. 935 – East Huron Street (Business I-94) Sewer Lining Project** and then list Respondents name and address.

Proposals must be addressed and delivered to:

City of Ann Arbor
Procurement Unit
c/o Customer Service Desk,
First Floor, Guy C. Larcom Building
301 East Huron Street
P.O. Box 8647
Ann Arbor, MI 48107

All Proposals received on or before the Due Date will be publicly opened and recorded immediately. No immediate decisions are rendered.

Hand delivered Proposals will be date/time stamped by the City at the address above in order to be considered. Delivery hours are 9:00 a.m. to 3:00 p.m. Monday through Friday, excluding Holidays.

The City will not be liable to any Respondent for any unforeseen circumstances, delivery, or postal delays. Postmarking on the Due Date will not substitute for receipt of the Proposal. Each Respondent is responsible for submission of their Proposal. Additional time will not be granted to a single Respondent; however, additional time may be granted to all Respondents when the City determines that circumstances warrant it.

A proposal will be disqualified if:

- 1. The fee proposal is not contained within a separate sealed envelope.*
- 2. The fee proposal is submitted as part of the digital copy. Provide fee proposal in hard copy only.*
- 3. The forms provided as Attachment C - City of Ann Arbor Prevailing Wage Declaration of Compliance, Attachment D - City of Ann Arbor Living Wage Ordinance Declaration of Compliance, Attachment E - Vendor Conflict of Interest Disclosure Form and Attachment F – City of Ann Arbor Non-Discrimination Declaration of Compliance of the RFP Document must be included in submitted proposals. Proposals that fail to provide these completed forms listed above upon*

proposal opening will be deemed non-responsive and will not be considered for award.

H. DISCLOSURES

Under the Freedom of Information Act (Public Act 442), the City is obligated to permit review of its files, if requested by others. All information in a Respondent's proposal is subject to disclosure under this provision. This act also provides for a complete disclosure of contracts and attachments thereto.

I. TYPE OF CONTRACT

A sample of the standard Sample Services Agreement is included as Attachment A. Those who wish to submit a proposal to the City are required to carefully review the Agreement. Respondents should specifically note that the insurance requirements under a City contract are listed in General Conditions. **The City will not entertain changes to terms and conditions of the standard Agreement.**

The City reserves the right to award the total proposal, to reject any and all proposals in whole or in part, and to waive any informality or technical defects if, in the City's sole judgment, the best interests of the City will be so served.

J. NONDISCRIMINATION AND LIVING WAGE REQUIREMENTS

The City's standard Agreement outlines the requirements for fair employment practices under City of Ann Arbor contracts. To establish compliance with this requirement, the respondent should complete and return with its proposal completed copies of the Non-Discrimination forms.

All respondents proposing to do business with the City of Ann Arbor, except those specifically exempted by regulations by the Administrator and approved by City Council, agree to comply with the living wage provisions of Chapter 23 of the Ann Arbor City Code and, if a "covered employer" as defined therein, to pay those employees providing services to the City under this agreement a "living wage" as defined in Chapter 23 of the Ann Arbor City Code; and, if requested by the City, provide documentation to verify compliance. Living Wage forms must be submitted with the proposal.

The following forms are attached:

- Living Wage Declaration form (Attachment D)
- Copy of the Current Living Wage poster (Attachment D)
- Non-Discrimination form (Attachment F)
- Non-Discrimination Ordinance poster (Attachment F)

K. CONFLICT OF INTEREST DISCLOSURE

The City of Ann Arbor Purchasing Policy requires that prospective Vendors complete a Conflict of Interest Disclosure form. A contract may not be awarded to the selected Vendor unless and until the Procurement Unit and the City Administrator have reviewed the Disclosure form and determined that no conflict exists under applicable federal, state, or local law or administrative regulation. Not every relationship or situation disclosed on the Disclosure Form may be a disqualifying conflict. Depending on applicable law and regulations, some contracts may awarded on the recommendation of the City Administrator after full disclosure, where such action is allowed by law, if demonstrated competitive pricing exists and/or it is determined the award is in the best interest of the City. A copy of the Vendor Conflict of Interest Disclosure Form is found in Attachment E and must be submitted with the proposal.

L. COST LIABILITY

The City of Ann Arbor assumes no responsibility or liability for costs incurred by the contractor prior to the execution of a Professional Services Agreement. The liability of the City is limited to the terms and conditions outlined in the Agreement. By submitting a Proposal, Respondent agrees to bear all costs incurred or related to the preparation, submission and selection process for the Proposal.

M. DEBARMENT

Submission of a proposal in response to this RFP is certification that the Respondent is not currently debarred, suspended, proposed for debarment, and declared ineligible or voluntarily excluded from participation in this transaction by any State or Federal departments or agency. Submission is also agreement that the City will be notified of any changes in this status.

N. AWARD PROTEST

All Proposal protests must be in writing and filed with the Purchasing Agent within five (5) business days of the award action. The respondent must clearly state the reasons for the protest. If a respondent contacts a City Service Area/Unit and indicates a desire to protest an award, the Service Area/Unit shall refer the respondent to the Purchasing Agent. The Purchasing Agent will provide the respondent with the appropriate instructions for filing the protest. The protest shall be reviewed by the City Administrator or designee whose decision shall be final.

O. SCHEDULE

The proposals submitted should define an appropriate schedule in accordance with the requirements of the Proposed Work Plan in Section III. The following is the solicitation schedule for this procurement:

Activity/Event	Anticipated Date
Pre-proposal Meeting	November 17, 2015 at 2:00 pm
Written Question Deadline	November 19, 2015 by 3:00 pm
Proposal Due Date	December 2, 2015 by 2:00 pm
Interview Contractors (if needed)	December 2015
Contractor Selection/Negotiate Final Professional Services Agreement (PSA)	TBD
Expected City Council Authorization of PSA	TBD
PSA Execution, Award and Notice to Proceed	TBD

The above schedule is for information purposes only and is subject to change at the City's discretion. Proposals submitted shall further define an appropriate project schedule in accordance with the requirements of the proposed work plan. The final schedule will be negotiated based on the final scope of work and work plan agreed to by the City and the selected firm.

P. IRS FORM W-9

The selected Respondent will be required to provide the City of Ann Arbor an IRS form W-9.

Q. INDEPENDENT FEE DETERMINATION

1. By submission of a proposal, the Respondent certifies, and in the case of joint proposal, each party thereto certifies as to its own organization, that in connection with this proposal:
 - a) They have arrived at the fees in the proposal independently, without consultation, communication, or agreement, for the purpose of restricting competition as to any matter relating to such fees with any other proposal Respondent or with any competitor.
 - b) Unless otherwise required by law, the fees which have been quoted in the proposal have not been knowingly disclosed by the Respondent and will not knowingly be disclosed by the Respondent prior to award directly or indirectly to any other prospective Respondent or to any competitor.
 - c) No attempt has been made or shall be made by the proposal Respondent to induce any other person or firm to submit or not submit a proposal for the purpose of restricting competition.

- d) Each person signing the proposal certifies that she or he is the person in the proposal Respondent's organization responsible within that organization for the decision as to the fees being offered in the proposal and has not participated (and will not participate) in any action contrary to 1.a), b), or c) above.
2. A proposal will not be considered for award if the sense of the statement required in the Fee Analysis portion of the proposal has been altered so as to delete or modify 1.a), or 1.c), If 1.b) has been modified or deleted, the proposal will not be considered for award unless the Respondent furnishes with the proposal a signed statement which sets forth in detail the circumstances of the disclosure and the Issuing Office determines that such disclosure was not made for the purpose of restricting competition.

R. RESERVATION OF RIGHTS

1. The City reserves the right in its sole and absolute discretion to accept or reject any or all Proposals or alternative Proposals, in whole or in part, with or without cause.
2. The City reserves the right to waive, or not waive, informalities or irregularities in bids or bidding procedures, and to accept or further negotiate cost, terms, or conditions of any bid determined by the City to be in the best interests of the City even though not the lowest bid.
3. The City reserves the right to request additional information from any or all Respondents.
4. The City reserves the right not to consider any Proposal which it determines to be unresponsive and deficient in any of the information requested within RFP.
5. The City reserves the right to determine whether the scope of the project will be entirely as described in the RFP, a portion of the scope, or a revised scope be implemented.
6. The City reserves the right to select one or more respondents to perform services.
7. The City reserves the right to retain all proposals submitted and to use any ideas in a proposal regardless of whether that proposal is selected. Submission of a proposal indicates acceptance by the firm of the conditions contained in this Request for Proposals, unless clearly and specifically noted in the proposal submitted.
8. The City reserves the right to disqualify Proposals that fail to respond to any requirements outlined in the RFP, or failure to enclose copies of the required documents outlined within the RFP.

SECTION II BACKGROUND AND SCOPE OF WORK

BACKGROUND

The following scope of services is to provide engineering services, construction services, oversight, and management services for the East Huron Street (Business I-94) Sewer Lining Project.

The City of Ann Arbor has an annual sewer televising and sewer lining program to line existing sanitary and storm sewers using standard Cured-In-Place Pipe (CIPP) lining methods.

As part of the sewer televising program performed in 2013, the 18" sanitary sewer segment upstream of manhole 71-70172 was noted to have multiple cracks and fractures and it was recommended to be lined. A copy of the sewer televising video of the 18" sanitary sewer is available at the City for review. If interested in picking up a copy of the video, please contact:

Igor Kotlyar, PE
ikotlyar@a2gov.org
(734) 794-6410 ext 43634

The 18" sanitary sewer segment, however, does not have an upstream manhole constructed directly over the sewer. Instead, the sewer terminates at a point inside the Central Power Plant parking lot adjacent to multiple below ground fuel storage tanks. A sanitary manhole (71-70183) is located approximately 5 to 7 feet (center of manhole to center of 18" pipe) southwest of the 18" sanitary pipe directly over the 24" sanitary pipe that blind taps the 18" pipe. Refer to Attachment K for a Site Plan of the sewer and surrounding area.

At the same time, the downstream manhole (MH 71-70172) contains two pipes, the 18" sanitary pipe as well as a 36" storm pipe that runs parallel to the 18" sanitary pipe and also bends near the Central Power Plant parking lot. The two pipes are separated in the manhole by a weir wall approximately 8 ft tall. Pictures of the manhole are also available at the City upon request.

The layout of the 18" sanitary pipe makes traditional CIPP lining of the pipe difficult.

The City of Ann Arbor is also required to eliminate cross connections between the sanitary and storm sewers in manhole 71-70172.

This RFP is to develop and present to the City a method that would be approved by the City of Ann Arbor to line the 18" sanitary sewer and to eliminate the potential for storm and sanitary cross connection in manhole 71-70172 and to perform the work upon approval by the City.

SCOPE OF WORK

Following is a description of the tasks and activities included in the program. All work performed by the Contractor shall be in accordance with the City's specifications, Michigan Occupational Safety and Health Administration (MIOSHA) requirements, Michigan Department

of Transportation (MDOT) requirements, and Michigan Manual of Uniform Traffic Control Devices (OMUTCD) requirements. The City's specifications can be found at: <http://www.a2gov.org/departments/engineering/Pages/Engineering-and-Contractor-Resources.aspx>.

The Contractor assigned to this project must demonstrate extensive experience with similar projects.

The following scope of work is intended as an outline only. Offerors should provide sufficient details on how they intend to implement each item of work.

A. Task 1 - 18" Sanitary Sewer Lining and Abandoning a Portion of 18" Sanitary Sewer Southeast of Manhole 71-70183

This task includes the lining of the 18" sanitary sewer upstream of Manhole 71-70172 and the proper abandonment of the 18" sanitary sewer southeast of Manhole 71-70183.

Task 1.a: 18" Sanitary Sewer Lining

The work shall include but is not limited to:

1. Clean and televise the 18" sanitary sewer prior to lining in accordance with NASSCO PACP requirements.
2. Note the location of any lateral connections and reconnect them after lining is complete.
3. Setup flow control procedure. Flows should be maintained within the existing pipe at all times if feasible. If bypass pumping is required, it shall be done in a method that does not impede traffic. At no time is bypass pumping piping allowed on E. Huron Street or Glen Avenue.
4. Trenchless lining of the sewer. At no time shall the sewer be excavated.
5. Termination of the lining at the manholes.
6. Perform all work through the existing manholes. At no time shall the construction of new manholes or pits be allowed.
7. Televise 18" sanitary sewer after lining.

Liner Requirements:

The liner selected for rehabilitation of the 18" sanitary sewer needs to provide structural strength in accordance with the requirements listed below. Assume the section of 18" sanitary sewer to be lined is "fully deteriorated pipe" as defined in:

- ASTM F1216 for "Rehabilitation of Existing Pipelines and Conduits by the Inversion and Curing of a Resin-Impregnated Tube"
- ASTM F1741 for "Installation of Machine Spiral Wound Poly (Vinyl Chloride) (PVC) Liner Pipe for Rehabilitation of Existing Sewers and Conduits".
- ASTM F1743 for "Rehabilitation of Existing Pipelines and Conduits by the Pulled-in-Place Installation of Cured-in-Place Thermosetting Resin Pipe (CIPP)".

Calculate the minimum required thickness or pipe stiffness and provide documentation and test data demonstrating the material properties will meet or exceed the minimum requirements. Also, provide material test data showing compliance with applicable ASTM Specifications.

For all Rehabilitation Methods:

- Flexural Strength: minimum 4,500 psi (short term)
- Flexural modulus: minimum 250,000 psi (short term)
- Creep Retention Factor: 50%
- Ovality: 2%
- Safety Factor: 2
- Soil Density: 130 lbs/cu. ft.
- Soil Modulus: 1,000 psi.
- Surcharge Loading: HS-20 (Highway)
- Material Minimum Service Life: 50 Years

The proposed liner material must be resistant to exposures to chemicals that may be found in the sewer including, but not limited to, raw sewage, hydrogen sulfide, sulfuric acid, and petroleum products. The liner material must also resist degradation resulting from shrinkage, elongation, swelling, blistering, softening, wrinkling, brittleness, peeling, bulging, delamination, and cracking. Provide documentation of the chemical resistance of the liner.

The liner must be water tight and prevent any infiltration from entering the sewer. Provide test data, narrative, and calculations that demonstrate effective water tightness for components of the liner including joints, seams, patches, and any other penetrations through the liner. Assume the water table is 28 feet above the top of pipe.

The liner shall maintain the existing gravity slope of the pipe. Also, the liner thickness shall be constant through the length of sewer that is repaired.

Task 1.b - Abandon Portion of 18" Sanitary Sewer Southeast of Manhole 71-70183

The work shall include but is not limited to:

1. Clean the abandoned segment of pipe and remove and dispose of the debris up to the existing bulkhead point.
2. Televiser the segment of pipe up to the existing bulkhead point.
3. Fill the sewer with flowable fill with the following mix design:
 - a. Compressive Strength Range $f'c$: 75 to 150 psi at 28 days.
 - b. Slump: 6 to 8 inches, minimum.
 - c. Air Content: 5% to 35%.
4. Place a 12" thick masonry bulkhead at the location shown on the drawing.

5. Since the length of the sewer segment to be abandoned is unknown at this time, the Contractor is to assume a total of 4 cubic yards of flowable fill.
6. Perform all work from Manhole 71-70183. At no time, is the Contractor allowed to excavate to the pipe or work inside the Central Power Plant parking lot.

As part of the Proposal, the Respondent is to provide a detailed written scope with sketches describing the following:

1. Preparation requirements for the existing pipe.
2. Type of liner to be used (name of product).
3. The liner manufacturer.
4. The liner thickness and design calculations for selection of wall thickness.
5. Proof of structural strength, chemical resistance, and water tightness requirements.
6. Proof that installation meets ASTM F1216, ASTM F1741, or ASTM F1743.
7. Method of installation.
8. Outline specific repair or replacement procedures for potential defects that may occur.
9. Role of Prime Contractor.
10. Role of Sub-Contractors.
11. Identify who will perform the installations and provide copies of appropriate certifications.
12. Proposed Liner and Installation Warranties (A minimum installation warranty of 1 year is required).
13. Method for abandoning, filling with flowable fill, and bulkheading the 18” sanitary pipe
14. Flowable fill mix design.
15. Time and effort required to complete the work.
16. Description of bypass pumping or flow control to be used. Flows should be maintained within the existing pipe at all time if feasible. If bypass pumping is required, it shall be done in a method that does not impede traffic. At no time is bypass pumping piping allowed on E. Huron Street or Glen Avenue.
17. Items/information needed from the City.
18. Additional traffic control needs beyond what is shown in Attachment L.
19. Provide any other information that would be helpful for the City to determine the most appropriate lining methods/contractor to be used.

B. Task 2 - Eliminate Sanitary and Storm Cross Connection in Manhole 71-70172 and Rehabilitate the Manhole

This tasks includes the elimination of the cross connection in Manhole 71-70172 and the rehabilitation of the brick manhole to provide water proofing, sealing, structural reinforcement, and corrosion protection.

The City proposes an option for the elimination of the cross connection (Refer to the description below and Attachment K for the layout of the option). The Respondent may propose an alternate option for the elimination of the cross connection, however, the Contractor must maintain the full opening of both the 18” and 36” pipes. No reduction in pipe capacity for either pipe shall be allowed.

The work shall include but is not limited to:

1. Elimination of the Cross Connection:

- a. The weir wall between the two pipes can be removed as long as the 36” enclosure is water tight to prevent any cross connections between the sanitary and storm pipes.
- b. The enclosure for the 36” pipe must be resistant to exposures to chemicals that may be found in either a storm or sanitary sewer including, but not limited to, raw sewage, hydrogen sulfide, sulfuric acid, and petroleum products. The enclosure material must also resist degradation resulting from shrinkage, elongation, swelling, blistering, softening, wrinkling, brittleness, peeling, bulging, delamination, and cracking. Provide documentation of the chemical resistance of the enclosure.
- c. Access from the surface to the 36” storm sewer inside the manhole can be eliminated.
- d. Access from the surface to the 18” sanitary sewer inside the manhole must remain.
- e. If a liner is chosen to enclose the 36” storm sewer, the liner shall be encased with concrete and reinforced to allow for a person to stand on it to work in the manhole. Respondent to provide sketch and calculations showing design.

2. Manhole Rehabilitation:

- a. Clean the manhole and remove any loose material.
- b. Plug any leaks.
- c. Rehabilitate the Manhole using a spray-on liner on any other application that provides water proofing, sealing, structural reinforcement, and corrosion protection.

If the Respondent intends to modify the manhole (including removing the top portion of the manhole) in order to perform the work described in either Task 1 or Task 2, the Respondent is to include what modifications are needed in their scope of work including depth and method of excavation. Any modifications to the manhole must be approved by the City.

As part of the Proposal, the Respondent is to provide a detailed written scope with sketches describing the following:

1. Procedure for eliminating the cross connection including sketches to show how the work will be done.

2. Material used to perform the separation.
3. Material used to rehabilitate the manhole. Material must have at least 5 years of successful performance in similar applications and be supplied by an ISO 9002 approved manufacturer
4. Time and effort required to complete the work.
5. Description of bypass pumping or flow control to be used. Flows should be maintained within the existing pipe at all time if feasible. If bypass pumping is required, it shall be done in a method that does not impede traffic. At no time is bypass pumping piping allowed on E. Huron Street or Glen Ave.
6. Identify who will perform the work.
7. Additional Traffic Control needs beyond what is shown in Attachment L.
8. Provide any other information that would be helpful for the City to determine the most appropriate contractor to be used.

C. General

The intent of this project is to perform all work inside the sewers; at no time shall the Contractor be allowed to excavate the sewers or manholes.

As part of their Proposal submittal, the Respondent shall provide an overall schedule of construction. Included in the schedule should be the anticipated start time based on the City's Notice to Proceed. Any seasonal limitations on work should be noted. The City expects the work to be completed expediently to minimize traffic disturbances to the residents and students. Work on site shall not exceed 45 calendar days from the date of mobilization, weather permitting.

The Respondent is to include all mobilization costs in their cost for each Task. At no time shall the Contractor be paid for mobilization even if the work will be separated into multiple phases with possibly multiple mobilization efforts.

All Traffic Control needed to perform any and all portions of the work is the responsibility of the Contractor and shall be included in the cost for each Task, regardless of the number of traffic control mobilizations and setups required.

The Contractor is responsible for applying for and acquiring all permits needed to perform the work including but not limited to City, County, State, SESC, Traffic, and all other permits. The costs for the permits shall be included in the Respondent's quote. The City will apply for an MDOT Construction Permit. The Contractor is required to pull the permit, comply with all permit requirements, and pay permit fees.

Respondent to note that the typical flow in the sanitary sewer is as follows:

Dry Weather Flow = 1.2 cfs

Wet Weather (10 year storm) = 1.7 cfs

All bypass pumping and/or flow control measures required for either the sanitary or storm pipes is the responsibility of the Contractor and shall be included in the cost for each Task. Flows shall be maintained within the existing pipe and or manholes at all time if feasible. If bypass pumping is required, it shall be done in a method that does not impede traffic. At no time is bypass pumping piping allowed on E. Huron Street or Glen Avenue.

Any damage to landscaping, private property, University of Michigan property, roads, curb and gutter, sidewalk, or existing utilities shall be repaired by the Contractor immediately at no cost to the project.

The Contractor shall confine his work to ROW property at all times. At no time, shall the Contractor enter private property, University of Michigan property, or perform any work in the parking lot of the Central Power Plant.

The entrance to the Central Power Plant parking lot shall remain open at all times.

SECTION III
MINIMUM INFORMATION REQUIRED

Respondents should organize their Proposals into the following Sections:

- A. Professional Qualifications
- B. Past Involvement with Similar Projects
- C. Proposed Work Plan
- D. Fee Proposal by Task (include in a separate sealed envelope clearly marked “Fee Proposal”)
- E. Authorized Negotiator
- F. Attachments

The following describes the elements that should be included in each of the proposal sections and the weighted point system that will be used for evaluation of the proposals.

A. Professional Qualifications and Past involvement with Similar Projects – 30 points

- 1. State the full name and address of your organization and, if applicable, the branch office, and **Major** sub-contractors that will perform, or assist in performing, the work hereunder.
- 2. Complete the attached Offeror’s Qualification Form (Attachment H) for the prime Contractor and each of the **Major** sub-contractors.
- 3. Provide a list of specific experience and indicate proven ability in implementing similar projects for the firm to be involved in the project. At a minimum, Prime Contractor, the firm manufacturing the liner and the firm installing the liner should each provide a minimum of three projects of similar size and type completed in the past 5 years. A complete list of client references must be provided for similar projects recently completed. It shall include the firm/agency name, address, telephone number, project title, and contact person. A form has been provided in Attachment I – Past involvement with Similar Projects. In addition to the information requested on the form, provide detailed explanations of the previous projects as part of the written proposal and any additional information that would be helpful for the City to determine the most appropriate Respondent to be used.
- 4. Provide any additional information on your qualifications or those of the **Major** sub-contractors that would be helpful for the City to determine the most appropriate Respondent to be used.

B. Proposed Work Plan – 50 points

Provide a detailed and comprehensive description of how the Respondent intends to complete the services requested in this RFP. This discussion shall include, but not be limited to items requested in Section II including an overall construction schedule.

Respondents will be evaluated on the clarity, thoroughness, and content of their responses to the above items.

C. Fee Proposal - 20 points

Fee schedules shall be submitted in a separate, sealed, envelope as part of the proposal using the attached form (Attachment J). Fee quotations are to include lump sum fees for each of the three tasks described in this RFP. The fee proposed must include the total estimated cost for the project when it is 100% complete and must include costs for mobilization, permits, flow control, and traffic control in the cost for each Task.

A sample of the required Services Agreement is included Attachment A.

D. Authorized Negotiator

Include the name, phone number, and e-mail address of persons(s) in your organization authorized to negotiate the Professional Services Agreement with the City.

E. Attachments

The following forms must be completed and returned with the proposal. These elements should be included as attachments to the proposal submission:

- Living Wage Forms (Attachment D)
- Non-Discrimination Disclosure (Attachment F)
- Vendor Conflict of Interest Disclosure Form (Attachment E)
- Offeror's Qualifications Form (Attachment H)
- Past Involvement with Similar Projects Form (Attachment I)
- Fee Proposal Form (Attachment J) - **Submitted in a separate sealed envelope marked fee proposal**

PROPOSAL EVALUATION

A selection committee composed of City staff will evaluate each proposal by the above described criteria and point system (A and B, based on 80 points) to select a short list of firms for further consideration. The City reserves the right to not consider any proposal which it determines to be unresponsive and deficient in any of the information requested for evaluation. A proposal with all the requested information does not guarantee the proposing firm to be a candidate for further consideration. The City may contact references to verify material submitted by the Respondents.

Interviews with the selected firms will be scheduled if deemed necessary by the City. At the interviews, the selected firms will be given the opportunity to discuss in more detail their qualifications, past experience, proposed work plan, and fee proposal. The interview must include the project team members expected to complete a majority of work on the project. The interview shall consist of a presentation of up to thirty (30) minutes by the Respondent,

including the person who will be the project manager on this Contract, followed by up to forty-five (45) minutes of questions and answers. Audiovisual aids may be used during the oral interviews. The oral interviews may be recorded on tape by the Evaluation Team.

The firms interviewed will then be re-evaluated by the above criteria (A through C), and adjustments to scoring will be made as appropriate. After evaluation of the proposals, further negotiation with the selected firm may be pursued leading to the award of a contract by City Council, if suitable proposals are received.

The City reserves the right to not consider any proposal which is determined to be unresponsive and deficient in any of the information requested for evaluation. The City also reserves the right to waive the interview process and evaluate the contractors based on their proposals and fee schedules alone.

The City will determine whether the final scope of the project to be negotiated will be entirely as described in this Request for Proposal, a portion of the scope, or a revised scope.

SECTION IV ATTACHMENTS

Attachment A – Sample Agreement

Attachment B – Legal Status of Respondent

Attachment C – Prevailing Wage Declaration of Compliance

Attachment D –Living Wage Declaration of Compliance and Poster

Attachment E – Vendor Conflict of Interest Disclosure Form

Attachment F – Non-Discrimination Declaration of Compliance and Poster

Attachment G – General Conditions

ATTACHMENT A - SAMPLE AGREEMENT

If a contract is awarded, the selected Firm(s) will be required to adhere to a set of general contract provisions which will become a part of any formal agreement. These provisions are general principles which apply to all contractors/service providers to the City of Ann Arbor. The required provisions are:

THIS AGREEMENT is made on the _____ day of _____, 2015, between the CITY OF ANN ARBOR, a Michigan Municipal Corporation, 301 East Huron Street, Ann Arbor, Michigan 48104 ("City") and _____ ("Contractor")

(An individual/partnership/corporation, include state of incorporation)
(Address)

Based upon the mutual promises below, the Contractor and the City agree as follows:

ARTICLE I - Scope of Work

The Contractor agrees to furnish all of the materials, equipment and labor necessary; and to abide by all the duties and responsibilities applicable to it for the project titled "On-Call Construction Services" in accordance with the requirements and provisions of the following documents, including all written modifications incorporated into any of the documents, which are incorporated as part of this Contract:

City Nondiscrimination Ordinance	General Conditions
Prevailing Wage Declaration of Compliance Forms	Standard Specifications
Living Wage Declaration of Compliance Forms	Detailed Specifications
Vendor Conflict of Interest Form	Plans
Bid Forms	Addenda
Contract and Exhibits	
Bonds	

ARTICLE II - Definitions

Administering Service Area/Unit means Public Services Area, Project Management.

Supervising Professional or Owner means persons acting under the authorization of the Administrator/Manager of the Administering Service Area/Unit.

Engineer or Owner's Representative means Consulting Professional acting under the authorization of the Supervising Professional/Owner.

Project means _____, No. _____

ARTICLE III - Time of Completion

- (A) The work to be completed under this Contract shall begin immediately on the date specified in the Notice to Proceed issued by the City.
- (B) The entire work for this Contract shall be completed by _____
- (C) Failure to complete all the work within the time specified above, including any extension granted in writing by the Supervising Professional, shall obligate the Contractor to pay the City, as liquidated damages and not as a penalty, an amount equal to \$0.00 for each calendar day of delay in the completion of all the work. If any liquidated damages are unpaid by the Contractor, the City shall be entitled to deduct these unpaid liquidated damages from the monies due the Contractor.

The liquidated damages are for the non-quantifiable aspects of any of the previously identified events and do not cover actual damages that can be shown or quantified nor are they intended to preclude recovery of actual damages in addition to the recovery of liquidated damages.

ARTICLE IV - The Contract Sum

- (A) The City shall pay to the Contractor for the performance of the Contract, the unit prices as given in the Bid Forms for the estimated bid total of:

_____ Dollars (\$_____)
- (B) The amount paid shall be equitably adjusted to cover changes in the work ordered by the Supervising Professional but not required by the Contract Documents. Increases or decreases shall be determined only by written agreement between the City and Contractor.

ARTICLE V - Assignment

- (A) The Contractor shall not subcontract or assign any portion of any right or obligation under this Agreement without prior written consent from the City. Notwithstanding any consent by the City to any assignment, Contractor shall at all times remain bound to all warranties, certifications, indemnifications, promises and performances, however described, as are required of it under the Agreement unless specifically released from the requirement, in writing, by the City.
- (B) The Contractor shall retain the right to pledge payment(s) due and payable under this Agreement to third parties.

ARTICLE VI - Choice of Law and Forum

This Agreement will be governed and controlled in all respects by the laws of the State of Michigan, including interpretation, enforceability, validity and construction, excepting the principles of conflicts of law. The parties submit to the jurisdiction and venue of the Circuit Court

for Washtenaw County, State of Michigan, or, if original jurisdiction can be established, the United States District Court for the Eastern District of Michigan, Southern Division, with respect to any action arising, directly or indirectly, out of this Agreement or the performance or breach of this Agreement. The parties stipulate that the venues referenced in this Agreement are convenient and waive any claim of non-convenience.

ARTICLE VII - Relationship of the Parties

The parties of the Contract agree that it is not a Contract of employment but is a Contract to accomplish a specific result. Contractor is an independent Contractor performing services for the City. Nothing contained in this Contract shall be deemed to constitute any other relationship between the City and the Contractor. Each Party will be solely responsible for the acts of its own employees, agents, and servants. No liability, right, or benefit arising out of any employer/employee relationship, either express or implied, shall arise or accrue to any Party as a result of this Agreement.

Contractor certifies that it has no personal or financial interest in the project other than the compensation it is to receive under the Contract. Contractor certifies that it is not, and shall not become, overdue or in default to the City for any Contract, debt, or any other obligation to the City including real or personal property taxes. City shall have the right to set off any such debt against compensation awarded for services under this agreement.

ARTICLE VIII - Notice

All notices and submissions required under this Agreement shall be delivered to the respective party in the manner described herein to the address stated in this Agreement or such other address as either party may designate by prior written notice to the other. Notices given under this Agreement shall be in writing and shall be personally delivered, sent by next day express delivery service, certified mail, or first class U.S. mail postage prepaid. Notice will be deemed given on the date when one of the following first occur: (1) the date of actual receipt; (2) the next business day when notice is sent next day express delivery service or personal delivery; or (3) three days after mailing first class or certified U.S. mail.

ARTICLE IX - Indemnification

To the fullest extent permitted by law, Contractor shall indemnify, defend and hold the City, its officers, employees and agents harmless from all suits, claims, judgments and expenses, including attorney's fees, resulting or alleged to result, from any acts or omissions by Contractor or its employees and agents occurring in the performance of or breach in this Agreement, except to the extent that any suit, claim, judgment or expense are finally judicially determined to have resulted from the City's negligence or willful misconduct or its failure to comply with any of its material obligations set forth in this Agreement.

ARTICLE X - Severability

Whenever possible, each provision of this Agreement will be interpreted in a manner as to be effective and valid under applicable law. However, if any provision of this Agreement or the application of any provision to any party or circumstance will be prohibited by or invalid under applicable law, that provision will be ineffective to the extent of the prohibition or invalidity without invalidating the remainder of the provisions of this Agreement or the application of the provision to other parties and circumstances.

ARTICLE XI - Entire Agreement

This Agreement, together with any affixed exhibits, schedules or other documentation, constitutes the entire understanding between the City and the Contractor with respect to the subject matter of the Agreement and it supersedes, unless otherwise incorporated by reference herein, all prior representations, negotiations, agreements or understandings whether written or oral. Neither party has relied on any prior representations, of any kind or nature, in entering into this Agreement. No terms or conditions of either party's invoice, purchase order or other administrative document shall modify the terms and conditions of this Agreement, regardless of the other party's failure to object to such form. This Agreement shall be binding on and shall inure to the benefit of the parties to this Agreement and their permitted successors and permitted assigns and nothing in this Agreement, express or implied, is intended to or shall confer on any other person or entity any legal or equitable right, benefit, or remedy of any nature whatsoever under or by reason of this Agreement. This Agreement may only be altered, amended or modified by written amendment signed by the Contractor and the City. This Agreement may be executed in counterparts, each of which shall be deemed an original, but all of which together shall be deemed to be one and the same agreement.

FOR CONTRACTOR

By _____

Its: _____

FOR THE CITY OF ANN ARBOR

By _____
Christopher Taylor, Mayor

By _____
Jacqueline Beaudry, City Clerk

Approved as to substance

By _____
City Administrator

By _____
Craig Hupy, Public
Services Area Administrator

Approved as to form and content

Stephen K. Postema, City Attorney

PERFORMANCE BOND

- (1) _____ (referred to as "Principal"), and _____, a corporation duly authorized to do business in the State of Michigan (referred to as "Surety"), are bound to the City of Ann Arbor, Michigan (referred to as "City"), for \$ _____, the payment of which Principal and Surety bind themselves, their heirs, executors, administrators, successors and assigns, jointly and severally, by this bond.
- (2) The Principal has entered a written Contract with the City dated _____, 201_, for: _____ and _____ this bond is given for that Contract in compliance with Act No. 213 of the Michigan Public Acts of 1963, as amended, being MCL 129.201 et seq.
- (3) Whenever the Principal is declared by the City to be in default under the Contract, the Surety may promptly remedy the default or shall promptly:
- (a) complete the Contract in accordance with its terms and conditions; or
 - (b) obtain a bid or bids for submission to the City for completing the Contract in accordance with its terms and conditions, and upon determination by Surety of the lowest responsible bidder, arrange for a Contract between such bidder and the City, and make available, as work progresses, sufficient funds to pay the cost of completion less the balance of the Contract price; but not exceeding, including other costs and damages for which Surety may be liable hereunder, the amount set forth in paragraph 1.
- (4) Surety shall have no obligation to the City if the Principal fully and promptly performs under the Contract.
- (5) Surety agrees that no change, extension of time, alteration or addition to the terms of the Contract or to the work to be performed thereunder, or the specifications accompanying it shall in any way affect its obligations on this bond, and waives notice of any such change, extension of time, alteration or addition to the terms of the Contract or to the work, or to the specifications.

SIGNED AND SEALED this _____ day of _____, 201_.

(Name of Surety Company)

By _____
(Signature)

Its _____
(Title of Office)

Approved as to form:

Stephen K. Postema, City Attorney

(Name of Principal)

By _____
(Signature)

Its _____
(Title of Office)

Name and address of agent:

LABOR AND MATERIAL BOND

- (1) _____
of _____ (referred to as "Principal"), and _____, a corporation duly authorized to do business in the State of Michigan, (referred to as "Surety"), are bound to the City of Ann Arbor, Michigan (referred to as "City"), for the use and benefit of claimants as defined in Act 213 of Michigan Public Acts of 1963, as amended, being MCL 129.201 et seq., in the amount of \$ _____, for the payment of which Principal and Surety bind themselves, their heirs, executors, administrators, successors and assigns, jointly and severally, by this bond.
- (2) The Principal has entered a written Contract with the City, dated _____, 201_, for _____; and this bond is given for that Contract in compliance with Act No. 213 of the Michigan Public Acts of 1963 as amended;
- (3) If the Principal fails to promptly and fully repay claimants for labor and material reasonably required under the Contract, the Surety shall pay those claimants.
- (4) Surety's obligations shall not exceed the amount stated in paragraph 1, and Surety shall have no obligation if the Principal promptly and fully pays the claimants.

SIGNED AND SEALED this _____ day of _____, 201_

(Name of Surety Company)
By _____
(Signature)
Its _____
(Title of Office)

(Name of Principal)
By _____
(Signature)
Its _____
(Title of Office)

Approved as to form:

Name and address of agent:

Stephen K. Postema, City Attorney

**ATTACHMENT B
LEGAL STATUS OF BIDDER**

(The Bidder shall fill out the appropriate form and strike out the other three.)

Bidder declares that it is:

* A corporation organized and doing business under the laws of the State of _____, for whom _____, bearing the office title of _____, whose signature is affixed to this Bid, is authorized to execute contracts.

NOTE: If not incorporated in Michigan, please attach the corporation's Certificate of Authority

• A limited liability company doing business under the laws of the State of _____, whom _____ bearing the title of _____ whose signature is affixed to this proposal, is authorized to execute contract on behalf of the LLC.

* A partnership, organized under the laws of the state of _____ and filed in the county of _____, whose members are (list all members and the street and mailing address of each) (attach separate sheet if necessary):

* An individual, whose signature with address, is affixed to this Bid: _____
(initial here)

Authorized Official

_____ **Date** _____, 201__

(Print) Name _____ Title _____

Company: _____

Address: _____

Contact Phone () _____ Fax () _____

Email _____

**ATTACHMENT C
CITY OF ANN ARBOR
PREVAILING WAGE DECLARATION OF COMPLIANCE**

The "wage and employment requirements" of Section 1:320 of Chapter 14 of Title I of the Ann Arbor City Code mandates that the city not enter any contract, understanding or other arrangement for a public improvement for or on behalf of the city unless the contract provides that all craftsmen, mechanics and laborers employed directly on the site in connection with said improvements, including said employees of subcontractors, shall receive the prevailing wage for the corresponding classes of craftsmen, mechanics and laborers, as determined by statistics for the Ann Arbor area compiled by the United States Department of Labor. Where the contract and the Ann Arbor City Code are silent as to definitions of terms required in determining contract compliance with regard to prevailing wages, the definitions provided in the Davis-Bacon Act as amended (40 U.S.C. 278-a to 276-a-7) for the terms shall be used. Further, to the extent that any employees of the contractor providing services under this contract are not part of the class of craftsmen, mechanics and laborers who receive a prevailing wage in conformance with section 1:320 of Chapter 14 of Title I of the Code of the City of Ann Arbor, employees shall be paid a prescribed minimum level of compensation (i.e. Living Wage) for the time those employees perform work on the contract in conformance with section 1:815 of Chapter 23 of Title I of the Code of the City of Ann Arbor.

At the request of the city, any contractor or subcontractor shall provide satisfactory proof of compliance with this provision.

The Contractor agrees:

- (a) To pay each of its employees whose wage level is required to comply with federal, state or local prevailing wage law, for work covered or funded by this contract with the City,
- (b) To require each subcontractor performing work covered or funded by this contract with the City to pay each of its employees the applicable prescribed wage level under the conditions stated in subsection (a) or (b) above.
- (c) To provide to the City payroll records or other documentation within ten (10) business days from the receipt of a request by the City.
- (d) To permit access to work sites to City representatives for the purposes of monitoring compliance, and investigating complaints or non-compliance.

The undersigned states that he/she has the requisite authority to act on behalf of his/her employer in these matters and has offered to provide the services in accordance with the terms of the wage and employment provisions of the Chapter 14 of the Ann Arbor City Code. The undersigned certifies that he/she has read and is familiar with the terms of Section 1:320 of Chapter 14 of the Ann Arbor City Code and by executing this Declaration of Compliance obligates his/her employer and any subcontractor employed by it to perform work on the contract to the wage and employment requirements stated herein. The undersigned further acknowledges and agrees that if it is found to be in violation of the wage and employment requirements of Section 1:320 of the Chapter 14 of the Ann Arbor City Code it shall have been deemed a material breach of the terms of the contract and grounds for termination of same by the City.

Company Name

Signature of Authorized Representative

Date

Print Name and Title

Address, City, State, Zip

Phone/Email address

Questions about this form? Contact Procurement Office City of Ann Arbor Phone: 734/794-6500

**ATTACHMENT D
CITY OF ANN ARBOR
LIVING WAGE ORDINANCE DECLARATION OF COMPLIANCE**

The Ann Arbor Living Wage Ordinance (Section 1:811-1:821 of Chapter 23 of Title I of the Code) requires that an employer who is (a) a contractor providing services to or for the City for a value greater than \$10,000 for any twelve-month contract term, or (b) a recipient of federal, state, or local grant funding administered by the City for a value greater than \$10,000, or (c) a recipient of financial assistance awarded by the City for a value greater than \$10,000, shall pay its employees a prescribed minimum level of compensation (i.e., Living Wage) for the time those employees perform work on the contract or in connection with the grant or financial assistance. The Living Wage must be paid to these employees for the length of the contract/program.

Companies employing fewer than 5 persons and non-profits employing fewer than 10 persons are exempt from compliance with the Living Wage Ordinance. If this exemption applies to your company/non-profit agency please check here [] No. of employees _____

The Contractor or Grantee agrees:

- (e) To pay each of its employees whose wage level is not required to comply with federal, state or local prevailing wage law, for work covered or funded by a contract with or grant from the City, no less than the Living Wage. The current Living Wage is defined as \$12.81/hour for those employers that provide employee health care (as defined in the Ordinance at Section 1:815 Sec. 1 (a)), or no less than \$14.30/hour for those employers that do not provide health care. The Contractor or Grantor understands that the Living Wage is adjusted and established annually on April 30 in accordance with the Ordinance and covered employers shall be required to pay the adjusted amount thereafter to be in compliance (Section 1:815(3)).

Check the applicable box below which applies to your workforce

[] Employees who are assigned to any covered City contract/grant will be paid at or above the applicable living wage without health benefits

[] Employees who are assigned to any covered City contract/grant will be paid at or above the applicable living wage with health benefits

- (f) To post a notice approved by the City regarding the applicability of the Living Wage Ordinance in every work place or other location in which employees or other persons contracting for employment are working.

- (g) To provide to the City payroll records or other documentation within ten (10) business days from the receipt of a request by the City.

- (h) To permit access to work sites to City representatives for the purposes of monitoring compliance, and investigating complaints or non-compliance.

- (i) To take no action that would reduce the compensation, wages, fringe benefits, or leave available to any employee covered by the Living Wage Ordinance or any person contracted for employment and covered by the Living Wage Ordinance in order to pay the living wage required by the Living Wage Ordinance.

The undersigned states that he/she has the requisite authority to act on behalf of his/her employer in these matters and has offered to provide the services or agrees to accept financial assistance in accordance with the terms of the Living Wage Ordinance. The undersigned certifies that he/she has read and is familiar with the terms of the Living Wage Ordinance, obligates the Employer/Grantee to those terms and acknowledges that if his/her employer is found to be in violation of Ordinance it may be subject to civil penalties and termination of the awarded contract or grant of financial assistance.

Company Name

Signature of Authorized Representative Date

Print Name and Title

Address, City, State, Zip

Phone/Email address

Questions about this form? Contact Procurement Office City of Ann Arbor Phone: 734/794-6500

**CITY OF ANN ARBOR
LIVING WAGE ORDINANCE**

RATE EFFECTIVE APRIL 30, 2015 - ENDING APRIL 29, 2016

\$12.81 per hour

If the employer provides health care benefits*

\$14.30 per hour

If the employer does **NOT** provide health care benefits*

Employers providing services to or for the City of Ann Arbor or recipients of grants or financial assistance from the City of Ann Arbor for a value of more than \$10,000 in a twelve-month period of time must pay those employees performing work on a City of Ann Arbor contract or grant, the above living wage.

ENFORCEMENT

The City of Ann Arbor may recover back wages either administratively or through court action for the employees that have been underpaid in violation of the law. Persons denied payment of the living wage have the right to bring a civil action for damages in addition to any action taken by the City.

Violation of this Ordinance is punishable by fines of not more than \$500/violation plus costs, with each day being considered a separate violation. Additionally, the City of Ann Arbor has the right to modify, terminate, cancel or suspend a contract in the event of a violation of the Ordinance.

* Health Care benefits include those paid for by the employer or making an employer contribution toward the purchase of health care. The employee contribution must not exceed \$.50 an hour for an average work week; and the employer cost or contribution must equal no less than \$1/hr for the average work week.

The Law Requires Employers to Display This Poster Where Employees Can Readily See It.

**For Additional Information or to File a Complaint Contact
Mark Berryman at 734/794-6500 or mberryman@a2gov.org**

ATTACHMENT E



Vendor Conflict of Interest Disclosure Form

All vendors interested in conducting business with the City of Ann Arbor must complete and return the Vendor Conflict of Interest Disclosure Form in order to be eligible to be awarded a contract. Please note that all vendors are subject to comply with the City of Ann Arbor's conflict interest policies as stated within the certification section below.

If a vendor has a relationship with a City of Ann Arbor official or employee, an immediate family member of a City of Ann Arbor official or employee, the vendor shall disclose the information required below.

Certification: I hereby certify that to my knowledge, there is no conflict of interest involving the vendor named below:

1. No City official or employee or City employee's immediate family member has an ownership interest in vendor's company or is deriving personal financial gain from this contract.
2. No retired or separated City official or employee who has been retired or separated from the City for less than one (1) year has an ownership interest in vendor's Company.
3. No City employee is contemporaneously employed or prospectively to be employed with the vendor.
4. Vendor hereby declares it has not and will not provide gifts or hospitality of any dollar value or any other gratuities to any City employee or elected official to obtain or maintain a contract.
5. Please note any exceptions below:

Vendor Name	Vendor Phone Number
Conflict of Interest Disclosure *	
Name of City of Ann Arbor employees, elected officials, or immediate family members with whom there may be a potential conflict of interest.	() Relationship to Employee _____ () Interest in vendor's company _____ () Other _____

*Disclosing a potential conflict of interest does not disqualify vendors. In the event vendors do not disclose potential conflicts of interest and they are detected by the City, vendor will be exempt from doing business with the City.

I certify that the information provided is true and correct by my signature below:

Signature of Vendor Authorized Representative	Date	Printed Name of Vendor Authorized Representative
---	------	--

PROCUREMENT USE ONLY

- Yes, named employee was involved in Bid / Proposal process.
- No, named employee was not involved in procurement process or decision

CITY OF ANN ARBOR NON-DISCRIMINATION ORDINANCE

Relevant provisions of Chapter 112, Nondiscrimination, of the Ann Arbor City Code are included below. You can review the entire ordinance at [www. a2gov.org/departments/city-clerk](http://www.a2gov.org/departments/city-clerk)

Intent: It is the intent of the city that no individual be denied equal protection of the laws; nor shall any individual be denied the enjoyment of his or her civil or political rights or be discriminated against because of actual or perceived age, arrest record, color, disability, educational association, familial status, family responsibilities, gender expression, gender identity, genetic information, height, HIV status, marital status, national origin, political beliefs, race, religion, sex, sexual orientation, source of income, veteran status, victim of domestic violence or stalking, or weight.

Discriminatory Employment Practices: No person shall discriminate in the hire, employment, compensation, work classifications, conditions or terms, promotion or demotion, or termination of employment of any individual. No person shall discriminate in limiting membership, conditions of membership or termination of membership in any labor union or apprenticeship program.

Discriminatory Effects: No person shall adopt, enforce or employ any policy or requirement which has the effect of creating unequal opportunities according to actual or perceived age, arrest record, color, disability, educational association, familial status, family responsibilities, gender expression, gender identity, genetic information, height, HIV status, marital status, national origin, political beliefs, race, religion, sex, sexual orientation, source of income, veteran status, victim of domestic violence or stalking, or weight for an individual to obtain housing, employment or public accommodation, except for a bona fide business necessity. Such a necessity does not arise due to a mere inconvenience or because of suspected objection to such a person by neighbors, customers or other persons.

Nondiscrimination by City Contractors: All contractors proposing to do business with the City of Ann Arbor shall satisfy the contract compliance administrative policy adopted by the City Administrator in accordance with the guidelines of this section. All city contractors shall ensure that applicants are employed and that employees are treated during employment in a manner which provides equal employment opportunity and tends to eliminate inequality based upon any classification protected by this chapter. All contractors shall agree not to discriminate against an employee or applicant for employment with respect to hire, tenure, terms, conditions, or privileges of employment, or a matter directly or indirectly related to employment, because of any applicable protected classification. All contractors shall be required to post a copy of Ann Arbor's Non-Discrimination Ordinance at all work locations where its employees provide services under a contract with the city.

Complaint Procedure: If any individual has a grievance alleging a violation of this chapter, he/she has 180 calendar days from the date of the individual's knowledge of the allegedly discriminatory action or 180 calendar days from the date when the individual should have known of the alleged discriminatory action to file a complaint with the city's Human Rights Commission. If an individual fails to file a complaint alleging a violation of this chapter within the specified time frame, the complaint will not be considered by the Human Rights Commission. The complaint should be made in writing to the Human Rights Commission. The complaint may be filed in person with the City Clerk, by e-mail at aahumanrightscommission@gmail.com, or by mail (Ann Arbor Human Rights Commission, PO Box 8647, Ann Arbor, MI 48107). The complaint must contain information about the alleged discrimination, such as name, address, phone number of the complainant and location, date and description of the alleged violation of this chapter.

Private Actions For Damages or Injunctive Relief: To the extent allowed by law, an individual who is the victim of discriminatory action in violation of this chapter may bring a civil action for appropriate injunctive relief or damages or both against the person(s) who acted in violation of this chapter

THIS IS AN OFFICIAL GOVERNMENT NOTICE AND
MUST BE DISPLAYED WHERE EMPLOYEES CAN READILY SEE IT.

ATTACHMENT G - GENERAL CONDITIONS

Section 1 - Execution, Correlation and Intent of Documents

The contract documents shall be signed in 2 copies by the City and the Contractor.

The contract documents are complementary and what is called for by any one shall be binding. The intention of the documents is to include all labor and materials, equipment and transportation necessary for the proper execution of the work. Materials or work described in words which so applied have a well-known technical or trade meaning have the meaning of those recognized standards.

In case of a conflict among the contract documents listed below in any requirement(s), the requirement(s) of the document listed first shall prevail over any conflicting requirement(s) of a document listed later.

(1) Addenda in reverse chronological order; (2) Detailed Specifications; (3) Standard Specifications; (4) Plans; (5) General Conditions; (6) Contract; (7) Bid Forms; (8) Bond Forms; (9) Bid.

Section 2 - Order of Completion

The Contractor shall submit with each invoice, and at other times reasonably requested by the Supervising Professional, schedules showing the order in which the Contractor proposes to carry on the work. They shall include the dates at which the Contractor will start the several parts of the work, the estimated dates of completion of the several parts, and important milestones within the several parts.

Section 3 - Familiarity with Work

The Bidder or its representative shall make personal investigations of the site of the work and of existing structures and shall determine to its own satisfaction the conditions to be encountered, the nature of the ground, the difficulties involved, and all other factors affecting the work proposed under this Contract. The Bidder to whom this Contract is awarded will not be entitled to any additional compensation unless conditions are clearly different from those which could reasonably have been anticipated by a person making diligent and thorough investigation of the site.

The Bidder shall immediately notify the City upon discovery, and in every case prior to submitting its Bid, of every error or omission in the bidding documents that would be identified by a reasonably competent, diligent Bidder. In no case will a Bidder be allowed the benefit of extra compensation or time to complete the work under this Contract for extra expenses or time spent as a result of the error or omission.

Section 4 - Wage Requirements

Under this Contract, the Contractor shall conform to Chapter 14 of Title I of the Code of the City of Ann Arbor as amended; which in part states "...that all craftsmen, mechanics and laborers employed directly on the site in connection with said improvements, including said employees of subcontractors, shall receive the prevailing wage for the corresponding classes of craftsmen,

mechanics and laborers, as determined by statistics for the Ann Arbor area compiled by the United States Department of Labor. At the request of the City, any contractor or subcontractor shall provide satisfactory proof of compliance with the contract provisions required by the Section."

Where the Contract and the Ann Arbor City Ordinance are silent as to definitions of terms required in determining contract compliance with regard to prevailing wages, the definitions provided in the Davis-Bacon Act as amended (40 U.S.C. 278-a to 276-a-7) for the terms shall be used.

Further, to the extent that any employees of the Contractor providing services under this contract are not part of the class of craftsmen, mechanics and laborers who receive a prevailing wage in conformance with Section 1:320 of Chapter 14 of Title I of the Code of the City of Ann Arbor, the Contractor agrees to conform to Chapter 23 of Title I of the Code of the City of Ann Arbor, as amended, which in part states:

1:814. Applicability.

- (1) This Chapter shall apply to any person that is a contractor/bidder or grantee as defined in Section 1:813 that employs or contracts with five (5) or more individuals; provided, however, that this Chapter shall not apply to a non-profit contractor/bidder or non-profit grantee unless it employs or contracts with ten (10) or more individuals.
- (2) This Chapter shall apply to any grant, contract, or subcontract or other form of financial assistance awarded to or entered into with a contractor/bidder or grantee after the effective date of this Chapter and to the extension or renewal after the effective date of this Chapter of any grant, contract, or subcontract or other form of financial assistance with a contractor/bidder or grantee.

1:815. Living Wages Required.

- (1) Every contractor/bidder or grantee, as defined in Section 1:813, shall pay its covered employees a living wage as established in this Section.
 - (a) For a covered employer that provides employee health care to its employees, the living wage shall be \$12.52 an hour, or the adjusted amount hereafter established under Section 1:815(3).
 - (b) For a covered employer that does not provide health care to its employees, the living wage shall be \$13.96 an hour, or the adjusted amount hereafter established under Section 1:815(3).
- (2) In order to qualify to pay the living wage rate for covered employers providing employee health care under subsection 1:815(1)(a), a covered employer shall furnish proof of said health care coverage and payment therefor to the City Administrator or his/her designee.
- (3) The amount of the living wage established in this Section shall be adjusted upward no later than April 30, 2002, and every year thereafter by a percentage equal to the percentage increase, if any, in the federal poverty guidelines as published by the United States Department of Health and Human Services for the years 2001 and 2002. Subsequent annual adjustments shall be based upon the percentage increase, if any, in

the United States Department of Health and Human Services poverty guidelines when comparing the prior calendar year's poverty guidelines to the present calendar year's guidelines. The applicable percentage amount will be converted to an amount in cents by multiplying the existing wage under Section 1.815(1)(b) by said percentage, rounding upward to the next cent, and adding this amount of cents to the existing living wage levels established under Sections 1:815(1)(a) and 1:815(1)(b). Prior to April 1 of each calendar year, the City will notify any covered employer of this adjustment by posting a written notice in a prominent place in City Hall, and, in the case of a covered employer that has provided an address of record to the City, by a written letter to each such covered employer.

Contractor agrees that all subcontracts entered into by the Contractor shall contain similar wage provision covering subcontractor's employees who perform work on this contract.

Section 5 - Non-Discrimination

The Contractor agrees to comply, and to require its subcontractor(s) to comply, with the nondiscrimination provisions of Section 209 of the Elliot-Larsen Civil Rights Act (MCL 37.2209). The Contractor further agrees to comply with the nondiscrimination provisions of Chapter 112 of the Ann Arbor City Code and to assure that applicants are employed and that employees are treated during employment in a manner which provides equal employment opportunity. The Contractor further agrees to comply with the provisions of Section 9:158 of Chapter 112 of the Ann Arbor City Code and in particular the following excerpts:

9:158. - Nondiscrimination by city contractors.

- (1) All contractors proposing to do business with the City of Ann Arbor shall satisfy the contract compliance administrative policy adopted by the City Administrator in accordance with the guidelines of this section. All city contractors shall ensure that applicants are employed and that employees are treated during employment in a manner which provides equal employment opportunity and tends to eliminate inequality based upon any classification protected by this chapter. All contractors shall agree not to discriminate against an employee or applicant for employment with respect to hire, tenure, terms, conditions, or privileges of employment, or a matter directly or indirectly related to employment, because of any applicable protected classification.
- (2) All contractors shall be required to post a copy of Ann Arbor's Non-Discrimination Ordinance at all work locations where its employees provide services under a contract with the city.
- (3) Upon request, each prospective contractor shall submit to the city data showing current total employment by occupational category, sex and minority group and shall respond to information requests documenting its equal employment opportunity policies and procedures.
- (4) If the contract which is being awarded includes federal requirements for affirmative action, each prospective contractor shall submit to the city data showing current total employment by occupational category, sex and minority group. If, after verifying this data, the City Administrator's designee concludes that it indicates total minority and female employment commensurate with their availability within the contractor's labor recruitment area, i.e., the area from which the contractor can reasonably be expected to recruit, said contractor shall be accepted by the City Administrator's designee as having fulfilled affirmative action requirements for the period of the contract at which time the City Administrator's designee

shall conduct another review. If the data demonstrates an under-representation the contractor shall develop an affirmative action program for review by the City Administrator's designee. Said program shall include specific goals and timetables for the hiring and promotion of minorities and females. Said goals shall reflect the availability of minorities and females within the contractor's labor recruitment area. In the case of construction contractors, the City Administrator's designee shall use for employment verification the labor recruitment area of the Ann Arbor metropolitan statistical area. Construction contractors determined to be in compliance shall be accepted by the City Administrator's designee as having fulfilled affirmative action requirements for a period of 1 year at which time the City Administrator's designee shall conduct another review.

- (5) In hiring for construction projects, contractors shall make good faith efforts to employ local persons, so as to enhance the local economy.
- (6) All contracts shall include provisions through which the contractor agrees to follow all applicable federal and state laws.
- (7) The City Administrator's designee shall monitor the compliance of each contractor with the nondiscrimination provisions of each contract. The City Administrator's designee, together with the Human Rights Commission, shall develop procedures and regulations consistent with the administrative policy adopted by the City Administrator for notice and enforcement of non-compliance. Such procedures and regulations shall include a provision for the posting of contractors not in compliance.
- (8) The City Administrator's designee will provide the City's Human Rights Commission with an annual summary report of contracts awarded; affirmative action requirements reviewed, where applicable; any complaints received alleging violation of the contractor's non-discrimination requirements, and actions taken. The Human Rights Commission will be provided, at its request, with additional information related to the report. The Human Rights Commission and the City Administrator's designee will report annually to the City Council on compliance of city contractors with this chapter.
- (9) All city contracts shall provide further that breach of the obligation not to discriminate shall be a material breach of the contract for which the city shall be entitled, at its option, to do any or all of the following:
 - (a) Cancel, terminate, or suspend the contract in whole or part and/or refuse to make any required periodic payments under the contract;
 - (b) Declare the contractor ineligible for the award of any future contracts with the city for a specified length of time;
 - (c) Recover liquidated damages of a specified sum, said sum to be that percentage of the labor expenditure for the time period involved which would have accrued to protected class members had the discrimination provisions not been breached;
 - (d) Impose for each day of non-compliance, liquidated damages of a specified sum, based upon the following schedule:

Contract Amount	Assessed Damages Per Day of Non-Compliance
\$25,000—99,999	\$50.00
100,000—199,999	100.00
200,000—499,999	150.00

500,000—1,499,999	200.00
1,500,000—2,999,999	250.00
3,000,000—4,999,999	300.00
5,000,000 and above	500.00

- (e) In addition the contractor shall be liable for any costs or expenses incurred by the City of Ann Arbor in obtaining from other sources the work and services to be rendered or performed or the goods or properties to be furnished or delivered to the city under this contract.

(Ord. No. 14-25, § 1, 10-20-14)

Section 6 - Materials, Appliances, Employees

Unless otherwise stipulated, the Contractor shall provide and pay for all materials, labor, water, tools, equipment, light, power, transportation, and other facilities necessary or used for the execution and completion of the work. Unless otherwise specified, all materials incorporated in the permanent work shall be new, and both workmanship and materials shall be of the highest quality. The Contractor shall, if required, furnish satisfactory evidence as to the kind and quality of materials.

The Contractor shall at all times enforce strict discipline and good order among its employees, and shall seek to avoid employing on the work any unfit person or anyone not skilled in the work assigned.

Adequate sanitary facilities shall be provided by the Contractor.

Section 7 - Qualifications for Employment

The Contractor shall employ competent laborers and mechanics for the work under this Contract. For work performed under this Contract, employment preference shall be given to qualified local residents.

Section 8 - Royalties and Patents

The Contractor shall pay all royalties and license fees. It shall defend all suits or claims for infringements of any patent rights and shall hold the City harmless from loss on account of infringement except that the City shall be responsible for all infringement loss when a particular process or the product of a particular manufacturer or manufacturers is specified, unless the City has notified the Contractor prior to the signing of the Contract that the particular process or product is patented or is believed to be patented.

Section 9 - Permits and Regulations

The Contractor must secure and pay for all permits, permit or plan review fees and licenses necessary for the prosecution of the work. These include but are not limited to City building permits, right-of-way permits, lane closure permits, right-of-way occupancy permits, and the like. The City shall secure and pay for easements shown on the plans unless otherwise specified.

The Contractor shall give all notices and comply with all laws, ordinances, rules and regulations bearing on the conduct of the work as drawn and specified. If the Contractor observes that the contract documents are at variance with those requirements, it shall promptly notify the Supervising Professional in writing, and any necessary changes shall be adjusted as provided in the Contract for changes in the work.

Section 10 - Protection of the Public and of Work and Property

The Contractor is responsible for the means, methods, sequences, techniques and procedures of construction and safety programs associated with the work contemplated by this contract. The Contractor, its agents or sub-contractors, shall comply with the "General Rules and Regulations for the Construction Industry" as published by the Construction Safety Commission of the State of Michigan and to all other local, State and National laws, ordinances, rules and regulations pertaining to safety of persons and property.

The Contractor shall take all necessary and reasonable precautions to protect the safety of the public. It shall continuously maintain adequate protection of all work from damage, and shall take all necessary and reasonable precautions to adequately protect all public and private property from injury or loss arising in connection with this Contract. It shall make good any damage, injury or loss to its work and to public and private property resulting from lack of reasonable protective precautions, except as may be due to errors in the contract documents, or caused by agents or employees of the City. The Contractor shall obtain and maintain sufficient insurance to cover damage to any City property at the site by any cause.

In an emergency affecting the safety of life, or the work, or of adjoining property, the Contractor is, without special instructions or authorization from the Supervising Professional, permitted to act at its discretion to prevent the threatened loss or injury. It shall also so act, without appeal, if authorized or instructed by the Supervising Professional.

Any compensation claimed by the Contractor for emergency work shall be determined by agreement or in accordance with the terms of Claims for Extra Cost - Section 15.

Section 11 - Inspection of Work

The City shall provide sufficient competent personnel for the inspection of the work.

The Supervising Professional shall at all times have access to the work whenever it is in preparation or progress, and the Contractor shall provide proper facilities for access and for inspection.

If the specifications, the Supervising Professional's instructions, laws, ordinances, or any public authority require any work to be specially tested or approved, the Contractor shall give the Supervising Professional timely notice of its readiness for inspection, and if the inspection is by

an authority other than the Supervising Professional, of the date fixed for the inspection. Inspections by the Supervising Professional shall be made promptly, and where practicable at the source of supply. If any work should be covered up without approval or consent of the Supervising Professional, it must, if required by the Supervising Professional, be uncovered for examination and properly restored at the Contractor's expense.

Re-examination of any work may be ordered by the Supervising Professional, and, if so ordered, the work must be uncovered by the Contractor. If the work is found to be in accordance with the contract documents, the City shall pay the cost of re-examination and replacement. If the work is not in accordance with the contract documents, the Contractor shall pay the cost.

Section 12 - Superintendence

The Contractor shall keep on the work site, during its progress, a competent superintendent and any necessary assistants, all satisfactory to the Supervising Professional. The superintendent will be responsible to perform all on-site project management for the Contractor. The superintendent shall be experienced in the work required for this Contract. The superintendent shall represent the Contractor and all direction given to the superintendent shall be binding as if given to the Contractor. Important directions shall immediately be confirmed in writing to the Contractor. Other directions will be confirmed on written request. The Contractor shall give efficient superintendence to the work, using its best skill and attention.

Section 13 - Changes in the Work

The City may make changes to the quantities of work within the general scope of the Contract at any time by a written order and without notice to the sureties. If the changes add to or deduct from the extent of the work, the Contract Sum shall be adjusted accordingly. All the changes shall be executed under the conditions of the original Contract except that any claim for extension of time caused by the change shall be adjusted at the time of ordering the change.

In giving instructions, the Supervising Professional shall have authority to make minor changes in the work not involving extra cost and not inconsistent with the purposes of the work, but otherwise, except in an emergency endangering life or property, no extra work or change shall be made unless in pursuance of a written order by the Supervising Professional, and no claim for an addition to the Contract Sum shall be valid unless the additional work was ordered in writing.

The Contractor shall proceed with the work as changed and the value of the work shall be determined as provided in Claims for Extra Cost - Section 15.

Section 14 - Extension of Time

Extension of time stipulated in the Contract for completion of the work will be made if and as the Supervising Professional may deem proper under any of the following circumstances:

- (1) When work under an extra work order is added to the work under this Contract;
- (2) When the work is suspended as provided in Section 20;

- (3) When the work of the Contractor is delayed on account of conditions which could not have been foreseen, or which were beyond the control of the Contractor, and which were not the result of its fault or negligence;
- (4) Delays in the progress of the work caused by any act or neglect of the City or of its employees or by other Contractors employed by the City;
- (5) Delay due to an act of Government;
- (6) Delay by the Supervising Professional in the furnishing of plans and necessary information;
- (7) Other cause which in the opinion of the Supervising Professional entitles the Contractor to an extension of time.

The Contractor shall notify the Supervising Professional within 7 days of an occurrence or conditions which, in the Contractor's opinion, entitle it to an extension of time. The notice shall be in writing and submitted in ample time to permit full investigation and evaluation of the Contractor's claim. The Supervising Professional shall acknowledge receipt of the Contractor's notice within 7 days of its receipt. Failure to timely provide the written notice shall constitute a waiver by the Contractor of any claim.

In situations where an extension of time in contract completion is appropriate under this or any other section of the contract, the Contractor understands and agrees that the only available adjustment for events that cause any delays in contract completion shall be extension of the required time for contract completion and that there shall be no adjustments in the money due the Contractor on account of the delay.

Section 15 - Claims for Extra Cost

If the Contractor claims that any instructions by drawings or other media issued after the date of the Contract involved extra cost under this Contract, it shall give the Supervising Professional written notice within 7 days after the receipt of the instructions, and in any event before proceeding to execute the work, except in emergency endangering life or property. The procedure shall then be as provided for Changes in the Work-Section I3. No claim shall be valid unless so made.

If the Supervising Professional orders, in writing, the performance of any work not covered by the contract documents, and for which no item of work is provided in the Contract, and for which no unit price or lump sum basis can be agreed upon, then the extra work shall be done on a Cost-Plus-Percentage basis of payment as follows:

- (1) The Contractor shall be reimbursed for all reasonable costs incurred in doing the work, and shall receive an additional payment of 15% of all the reasonable costs to cover both its indirect overhead costs and profit;
- (2) The term "Cost" shall cover all payroll charges for employees and supervision required under the specific order, together with all worker's compensation, Social Security, pension and retirement allowances and social insurance, or other regular payroll charges on same; the cost of all material and supplies required of either temporary or

permanent character; rental of all power-driven equipment at agreed upon rates, together with cost of fuel and supply charges for the equipment; and any costs incurred by the Contractor as a direct result of executing the order, if approved by the Supervising Professional;

- (3) If the extra is performed under subcontract, the subcontractor shall be allowed to compute its charges as described above. The Contractor shall be permitted to add an additional charge of 5% percent to that of the subcontractor for the Contractor's supervision and contractual responsibility;
- (4) The quantities and items of work done each day shall be submitted to the Supervising Professional in a satisfactory form on the succeeding day, and shall be approved by the Supervising Professional and the Contractor or adjusted at once;
- (5) Payments of all charges for work under this Section in any one month shall be made along with normal progress payments. Retainage shall be in accordance with Progress Payments-Section 16.

No additional compensation will be provided for additional equipment, materials, personnel, overtime or special charges required to perform the work within the time requirements of the Contract.

When extra work is required and no suitable price for machinery and equipment can be determined in accordance with this Section, the hourly rate paid shall be 1/40 of the basic weekly rate listed in the Rental Rate Blue Book published by Dataquest Incorporated and applicable to the time period the equipment was first used for the extra work. The hourly rate will be deemed to include all costs of operation such as bucket or blade, fuel, maintenance, "regional factors", insurance, taxes, and the like, but not the costs of the operator.

Section 16 - Progress Payments

The Contractor shall submit each month, or at longer intervals, if it so desires, an invoice covering work performed for which it believes payment, under the Contract terms, is due. The submission shall be to the City's Finance Department - Accounting Division. The Supervising Professional will, within 10 days following submission of the invoice, prepare a certificate for payment for the work in an amount to be determined by the Supervising Professional as fairly representing the acceptable work performed during the period covered by the Contractor's invoice. To insure the proper performance of this Contract, the City will retain a percentage of the estimate in accordance with Act 524, Public Acts of 1980. The City will then, following the receipt of the Supervising Professional's Certificate, make payment to the Contractor as soon as feasible, which is anticipated will be within 15 days.

An allowance may be made in progress payments if substantial quantities of permanent material have been delivered to the site but not incorporated in the completed work if the Contractor, in the opinion of the Supervising Professional, is diligently pursuing the work under this Contract. Such materials shall be properly stored and adequately protected. Allowance in the estimate shall be at the invoice price value of the items. Notwithstanding any payment of any allowance, all risk of loss due to vandalism or any damages to the stored materials remains with the Contractor.

In the case of Contracts which include only the Furnishing and Delivering of Equipment, the payments shall be; 60% of the Contract Sum upon the delivery of all equipment to be furnished, or in the case of delivery of a usable portion of the equipment in advance of the total equipment delivery, 60% of the estimated value of the portion of the equipment may be paid upon its delivery in advance of the time of the remainder of the equipment to be furnished; 30% of the Contract Sum upon completion of erection of all equipment furnished, but not later than 60 days after the date of delivery of all of the equipment to be furnished; and payment of the final 10% on final completion of erection, testing and acceptance of all the equipment to be furnished; but not later than 180 days after the date of delivery of all of the equipment to be furnished, unless testing has been completed and shows the equipment to be unacceptable.

With each invoice for periodic payment, the Contractor shall enclose a Contractor's Declaration - Section 43, and an updated project schedule per Order of Completion - Section 2.

Section 17 - Deductions for Uncorrected Work

If the Supervising Professional decides it is inexpedient to correct work that has been damaged or that was not done in accordance with the Contract, an equitable deduction from the Contract price shall be made.

Section 18 - Correction of Work Before Final Payment

The Contractor shall promptly remove from the premises all materials condemned by the Supervising Professional as failing to meet Contract requirements, whether incorporated in the work or not, and the Contractor shall promptly replace and re-execute the work in accordance with the Contract and without expense to the City and shall bear the expense of making good all work of other contractors destroyed or damaged by the removal or replacement.

If the Contractor does not remove the condemned work and materials within 10 days after written notice, the City may remove them and, if the removed material has value, may store the material at the expense of the Contractor. If the Contractor does not pay the expense of the removal within 10 days thereafter, the City may, upon 10 days written notice, sell the removed materials at auction or private sale and shall pay to the Contractor the net proceeds, after deducting all costs and expenses that should have been borne by the Contractor. If the removed material has no value, the Contractor must pay the City the expenses for disposal within 10 days of invoice for the disposal costs.

The inspection or lack of inspection of any material or work pertaining to this Contract shall not relieve the Contractor of its obligation to fulfill this Contract and defective work shall be made good. Unsuitable materials may be rejected by the Supervising Professional notwithstanding that the work and materials have been previously overlooked by the Supervising Professional and accepted or estimated for payment or paid for. If the work or any part shall be found defective at any time before the final acceptance of the whole work, the Contractor shall forthwith make good the defect in a manner satisfactory to the Supervising Professional. The judgment and the decision of the Supervising Professional as to whether the materials supplied and the work done under this Contract comply with the requirements of the Contract shall be conclusive and final.

Section 19 - Acceptance and Final Payment

Upon receipt of written notice that the work is ready for final inspection and acceptance, the Supervising Professional will promptly make the inspection. When the Supervising Professional finds the work acceptable under the Contract and the Contract fully performed, the Supervising Professional will promptly sign and issue a final certificate stating that the work required by this Contract has been completed and is accepted by the City under the terms and conditions of the Contract. The entire balance found to be due the Contractor, including the retained percentage, shall be paid to the Contractor by the City within 30 days after the date of the final certificate.

Before issuance of final certificates, the Contractor shall file with the City:

- (1) The consent of the surety to payment of the final estimate;
- (2) The Contractor's Affidavit in the form required by Section 44.

In case the Affidavit or consent is not furnished, the City may retain out of any amount due the Contractor, sums sufficient to cover all lienable claims.

The making and acceptance of the final payment shall constitute a waiver of all claims by the City except those arising from:

- (1) unsettled liens;
- (2) faulty work appearing within 12 months after final payment;
- (3) hidden defects in meeting the requirements of the plans and specifications;
- (4) manufacturer's guarantees.

It shall also constitute a waiver of all claims by the Contractor, except those previously made and still unsettled.

Section 20 - Suspension of Work

The City may at any time suspend the work, or any part by giving 5 days notice to the Contractor in writing. The work shall be resumed by the Contractor within 10 days after the date fixed in the written notice from the City to the Contractor to do so. The City shall reimburse the Contractor for expense incurred by the Contractor in connection with the work under this Contract as a result of the suspension.

If the work, or any part, shall be stopped by the notice in writing, and if the City does not give notice in writing to the Contractor to resume work at a date within 90 days of the date fixed in the written notice to suspend, then the Contractor may abandon that portion of the work suspended and will be entitled to the estimates and payments for all work done on the portions abandoned, if any, plus 10% of the value of the work abandoned, to compensate for loss of overhead, plant expense, and anticipated profit.

Section 21 - Delays and the City's Right to Terminate Contract

If the Contractor refuses or fails to prosecute the work, or any separate part of it, with the diligence required to insure completion, ready for operation, within the allowable number of consecutive calendar days specified plus extensions, or fails to complete the work within the required time, the City may, by written notice to the Contractor, terminate its right to proceed

with the work or any part of the work as to which there has been delay. After providing the notice the City may take over the work and prosecute it to completion, by contract or otherwise, and the Contractor and its sureties shall be liable to the City for any excess cost to the City. If the Contractor's right to proceed is terminated, the City may take possession of and utilize in completing the work, any materials, appliances and plant as may be on the site of the work and useful for completing the work. The right of the Contractor to proceed shall not be terminated or the Contractor charged with liquidated damages where an extension of time is granted under Extension of Time - Section 14.

If the Contractor is adjudged a bankrupt, or if it makes a general assignment for the benefit of creditors, or if a receiver is appointed on account of its insolvency, or if it persistently or repeatedly refuses or fails except in cases for which extension of time is provided, to supply enough properly skilled workers or proper materials, or if it fails to make prompt payments to subcontractors or for material or labor, or persistently disregards laws, ordinances or the instructions of the Supervising Professional, or otherwise is guilty of a substantial violation of any provision of the Contract, then the City, upon the certificate of the Supervising Professional that sufficient cause exists to justify such action, may, without prejudice to any other right or remedy and after giving the Contractor 3 days written notice, terminate this Contract. The City may then take possession of the premises and of all materials, tools and appliances thereon and without prejudice to any other remedy it may have, make good the deficiencies or finish the work by whatever method it may deem expedient, and deduct the cost from the payment due the Contractor. The Contractor shall not be entitled to receive any further payment until the work is finished. If the expense of finishing the work, including compensation for additional managerial and administrative services exceeds the unpaid balance of the Contract Sum, the Contractor and its surety are liable to the City for any excess cost incurred. The expense incurred by the City, and the damage incurred through the Contractor's default, shall be certified by the Supervising Professional.

Section 22 - Contractor's Right to Terminate Contract

If the work should be stopped under an order of any court, or other public authority, for a period of 3 months, through no act or fault of the Contractor or of anyone employed by it, then the Contractor may, upon 7 days written notice to the City, terminate this Contract and recover from the City payment for all acceptable work executed plus reasonable profit.

Section 23 - City's Right To Do Work

If the Contractor should neglect to prosecute the work properly or fail to perform any provision of this Contract, the City, 3 days after giving written notice to the Contractor and its surety may, without prejudice to any other remedy the City may have, make good the deficiencies and may deduct the cost from the payment due to the Contractor.

Section 24 - Removal of Equipment and Supplies

In case of termination of this Contract before completion, from any or no cause, the Contractor, if notified to do so by the City, shall promptly remove any part or all of its equipment and supplies from the property of the City, failing which the City shall have the right to remove the equipment and supplies at the expense of the Contractor.

The removed equipment and supplies may be stored by the City and, if all costs of removal and

storage are not paid by the Contractor within 10 days of invoicing, the City upon 10 days written notice may sell the equipment and supplies at auction or private sale, and shall pay the Contractor the net proceeds after deducting all costs and expenses that should have been borne by the Contractor and after deducting all amounts claimed due by any lien holder of the equipment or supplies.

Section 25 - Responsibility for Work and Warranties

The Contractor assumes full responsibility for any and all materials and equipment used in the construction of the work and may not make claims against the City for damages to materials and equipment from any cause except negligence or willful act of the City. Until its final acceptance, the Contractor shall be responsible for damage to or destruction of the project (except for any part covered by Partial Completion and Acceptance - Section 26). The Contractor shall make good all work damaged or destroyed before acceptance. All risk of loss remains with the Contractor until final acceptance of the work (Section 19) or partial acceptance (Section 26). The Contractor is advised to investigate obtaining its own builders risk insurance.

The Contractor shall guarantee the quality of the work for a period of one year. The Contractor shall also unconditionally guarantee the quality of all equipment and materials that are furnished and installed under the contract for a period of one year. At the end of one year after the Contractor's receipt of final payment, the complete work, including equipment and materials furnished and installed under the contract, shall be inspected by the Contractor and the Supervising Professional. Any defects shall be corrected by the Contractor at its expense as soon as practicable but in all cases within 60 days. Any defects that are identified prior to the end of one year shall also be inspected by the Contractor and the Supervising Professional and shall be corrected by the Contractor at its expense as soon as practicable but in all cases within 60 days.

The Contractor shall assign all manufacturer or material supplier warranties to the City prior to final payment. The assignment shall not relieve the Contractor of its obligations under this paragraph to correct defects.

Section 26 - Partial Completion and Acceptance

If at any time prior to the issuance of the final certificate referred to in Acceptance and Final Payment - Section 19, any portion of the permanent construction has been satisfactorily completed, and if the Supervising Professional determines that portion of the permanent construction is not required for the operations of the Contractor but is needed by the City, the Supervising Professional shall issue to the Contractor a certificate of partial completion, and immediately the City may take over and use the portion of the permanent construction described in the certificate, and exclude the Contractor from that portion.

The issuance of a certificate of partial completion shall not constitute an extension of the Contractor's time to complete the portion of the permanent construction to which it relates if the Contractor has failed to complete it in accordance with the terms of this Contract. The issuance of the certificate shall not release the Contractor or its sureties from any obligations under this Contract including bonds.

If prior use increases the cost of, or delays the work, the Contractor shall be entitled to extra compensation, or extension of time, or both, as the Supervising Professional may determine.

Section 27 - Payments Withheld Prior to Final Acceptance of Work

The City may withhold or, on account of subsequently discovered evidence, nullify the whole or part of any certificate to the extent reasonably appropriate to protect the City from loss on account of:

- (1) Defective work not remedied;
- (2) Claims filed or reasonable evidence indicating probable filing of claims by other parties against the Contractor;
- (3) Failure of the Contractor to make payments properly to subcontractors or for material or labor;
- (4) Damage to another Contractor.

When the above grounds are removed or the Contractor provides a Surety Bond satisfactory to the City which will protect the City in the amount withheld, payment shall be made for amounts withheld under this section.

Section 28 - Contractor's Insurance

- (1) The Contractor shall procure and maintain during the life of this Contract, including the guarantee period and during any warranty work, such insurance policies, including those set forth below, as will protect itself and the City from all claims for bodily injuries, death or property damage which may arise under this Contract; whether the acts were made by the Contractor or by any subcontractor or anyone employed by them directly or indirectly. The following insurance policies are required:
 - (a) Worker's Compensation Insurance in accordance with all applicable state and federal statutes. Further, Employers Liability Coverage shall be obtained in the following minimum amounts:
 - Bodily Injury by Accident - \$500,000 each accident
 - Bodily Injury by Disease - \$500,000 each employee
 - Bodily Injury by Disease - \$500,000 each policy limit
 - (b) Commercial General Liability Insurance equivalent to, as a minimum, Insurance Services Office form CG 00 01 07 98. The City of Ann Arbor shall be named as an additional insured. There shall be no added exclusions or limiting endorsements specifically for the following coverages: Products and Completed Operations, Explosion, Collapse and Underground coverage or Pollution. Further there shall be no added exclusions or limiting endorsements which diminish the City's protections as an additional insured under the policy. The following minimum limits of liability are required:
 - \$1,000,000 Each occurrence as respect Bodily Injury Liability or Property Damage Liability, or both combined.
 - \$2,000,000 Per Job General Aggregate

\$1,000,000 Personal and Advertising Injury
\$2,000,000 Products and Completed Operations Aggregate

- (c) Motor Vehicle Liability Insurance, including Michigan No-Fault Coverages, equivalent to, as a minimum, Insurance Services Office form CA 00 01 07 97. The City of Ann Arbor shall be named as an additional insured. There shall be no added exclusions or limiting endorsements which diminish the City's protections as an additional insured under the policy. Coverage shall include all owned vehicles, all non-owned vehicles and all hired vehicles. Further, the limits of liability shall be \$1,000,000 for each occurrence as respects Bodily Injury Liability or Property Damage Liability, or both combined.
- (d) Umbrella/Excess Liability Insurance shall be provided to apply excess of the Commercial General Liability, Employers Liability and the Motor Vehicle coverage enumerated above, for each occurrence and for aggregate in the amount of \$1,000,000.
- (2) Insurance required under subsection (1)(b) and (1)(c) above shall be considered primary as respects any other valid or collectible insurance that the City may possess, including any self-insured retentions the City may have; and any other insurance the City does possess shall be considered excess insurance only and shall not be required to contribute with this insurance. Further, the Contractor agrees to waive any right of recovery by its insurer against the City.
- (3) In the case of all Contracts involving on-site work, the Contractor shall provide to the City before the commencement of any work under this Contract documentation demonstrating it has obtained the above mentioned policies. Documentation must provide and demonstrate an unconditional 30 day written notice of cancellation in favor of the City of Ann Arbor. Further, the documentation must explicitly state the following: (a) the policy number; name of insurance company; name and address of the agent or authorized representative; name and address of insured; project name; policy expiration date; and specific coverage amounts; (b) any deductibles or self-insured retentions which shall be approved by the City, in its sole discretion; (c) that the policy conforms to the requirements specified. An original certificate of insurance may be provided as an initial indication of the required insurance, provided that no later than 21 calendar days after commencement of any work the Contractor supplies a copy of the endorsements required on the policies. Upon request, the Contractor shall provide within 30 days a copy of the policy(ies) to the City. If any of the above coverages expire by their terms during the term of this Contract, the Contractor shall deliver proof of renewal and/or new policies to the Administering Service Area/Unit at least ten days prior to the expiration date.
- (4) Any Insurance provider of Contractor shall be admitted and authorized to do business in the State of Michigan and shall carry and maintain a minimum rating assigned by A.M. Best & Company's Key Rating Guide of "A-" Overall and a minimum Financial Size Category of "V". Insurance policies and certificates issued by non-admitted insurance companies are not acceptable unless approved in writing by the City.

Section 29 - Surety Bonds

Bonds will be required from the successful bidder as follows:

- (1) A Performance Bond to the City of Ann Arbor for the amount of the bid(s) accepted;
- (2) A Labor and Material Bond to the City of Ann Arbor for the amount of the bid(s) accepted.

Bonds shall be executed on forms supplied by the City in a manner and by a Surety Company authorized to transact business in Michigan and satisfactory to the City Attorney.

Section 30 - Damage Claims

The Contractor shall be held responsible for all damages to property of the City or others, caused by or resulting from the negligence of the Contractor, its employees, or agents during the progress of or connected with the prosecution of the work, whether within the limits of the work or elsewhere. The Contractor must restore all property injured including sidewalks, curbing, sodding, pipes, conduit, sewers or other public or private property to not less than its original condition with new work.

Section 31 - Refusal to Obey Instructions

If the Contractor refuses to obey the instructions of the Supervising Professional, the Supervising Professional shall withdraw inspection from the work, and no payments will be made for work performed thereafter nor may work be performed thereafter until the Supervising Professional shall have again authorized the work to proceed.

Section 32 - Assignment

Neither party to the Contract shall assign the Contract without the written consent of the other. The Contractor may assign any monies due to it to a third party acceptable to the City.

Section 33 - Rights of Various Interests

Whenever work being done by the City's forces or by other contractors is contiguous to work covered by this Contract, the respective rights of the various interests involved shall be established by the Supervising Professional, to secure the completion of the various portions of the work in general harmony.

The Contractor is responsible to coordinate all aspects of the work, including coordination of, and with, utility companies and other contractors whose work impacts this project.

Section 34 - Subcontracts

The Contractor shall not award any work to any subcontractor without prior written approval of the City. The approval will not be given until the Contractor submits to the City a written statement concerning the proposed award to the subcontractor. The statement shall contain all information the City may require.

The Contractor shall be as fully responsible to the City for the acts and omissions of its subcontractors, and of persons either directly or indirectly employed by them, as it is for the acts and omissions of persons directly employed by it.

The Contractor shall cause appropriate provisions to be inserted in all subcontracts relative to the work to bind subcontractors to the Contractor by the terms of the General Conditions and all other contract documents applicable to the work of the subcontractors and to give the Contractor the same power to terminate any subcontract that the City may exercise over the Contractor under any provision of the contract documents.

Nothing contained in the contract documents shall create any contractual relation between any subcontractor and the City.

Section 35 - Supervising Professional's Status

The Supervising Professional has the right to inspect any or all work. The Supervising Professional has authority to stop the work whenever stoppage may be appropriate to insure the proper execution of the Contract. The Supervising Professional has the authority to reject all work and materials which do not conform to the Contract and to decide questions which arise in the execution of the work.

The Supervising Professional shall make all measurements and determinations of quantities. Those measurements and determinations are final and conclusive between the parties.

Section 36 - Supervising Professional's Decisions

The Supervising Professional shall, within a reasonable time after their presentation to the Supervising Professional, make decisions in writing on all claims of the City or the Contractor and on all other matters relating to the execution and progress of the work or the interpretation of the contract documents.

Section 37 - Storing Materials and Supplies

Materials and supplies may be stored at the site of the work at locations agreeable to the City unless specific exception is listed elsewhere in these documents. Ample way for foot traffic and drainage must be provided, and gutters must, at all times, be kept free from obstruction. Traffic on streets shall be interfered with as little as possible. The Contractor may not enter or occupy with agents, employees, tools, or material any private property without first obtaining written permission from its owner. A copy of the permission shall be furnished to the Supervising Professional.

Section 38 - Lands for Work

The Contractor shall provide, at its own expense and without liability to the City, any additional land and access that may be required for temporary construction facilities or for storage of materials.

Section 39 - Cleaning Up

The Contractor shall, as directed by the Supervising Professional, remove at its own expense from the City's property and from all public and private property all temporary structures, rubbish and waste materials resulting from its operations unless otherwise specifically approved, in writing, by the Supervising Professional.

Section 40 - Salvage

The Supervising Professional may designate for salvage any materials from existing structures or underground services. Materials so designated remain City property and shall be transported or stored at a location as the Supervising Professional may direct.

Section 41 - Night, Saturday or Sunday Work

No night or Sunday work (without prior written City approval) will be permitted except in the case of an emergency and then only to the extent absolutely necessary. The City may allow night work which, in the opinion of the Supervising Professional, can be satisfactorily performed at night. Night work is any work between 8:00 p.m. and 7:00 a.m. No Saturday work will be permitted unless the Contractor gives the Supervising Professional at least 48 hours but not more than 5 days notice of the Contractor's intention to work the upcoming Saturday.

Section 42 - Sales Taxes

Under State law the City is exempt from the assessment of State Sales Tax on its direct purchases. Contractors who acquire materials, equipment, supplies, etc. for incorporation in City projects are not likewise exempt. State Law shall prevail. The Bidder shall familiarize itself with the State Law and prepare its Bid accordingly. No extra payment will be allowed under this Contract for failure of the Contractor to make proper allowance in this bid for taxes it must pay.

OFFEROR'S QUALIFICATIONS

The City of Ann Arbor is committed to providing a safe, healthy workplace for all employees, contractors and neighbors. The Contractor selected must demonstrate management leadership and systems resulting in excellent safety performance.

To be selected to perform on-site work, the contractor must:

- Have a documented **ENVIRONMENTAL, SAFETY & HEALTH** program that meets government requirements applicable to your work (Copy to be provided within 48 hours of request).
- Have a OSHA/BLS Recordable Injury Frequency Rate equal to or less than the average rate for applicable industry.
- Agree that all subcontractors employed by the contractor will meet the requirements listed above and submit a suitable qualification questionnaire.
- Provide supporting **ENVIRONMENTAL, SAFETY & HEALTH** information as requested to verify the contractor's ability to comply with applicable health and safety requirements.
- Require that all contractor employees, and visitors must communicate with a level of proficiency, and to the extent necessary, to ensure their safety and the safety of others.

PROPOSER'S QUALIFICATIONS QUESTIONNAIRE
(Must be completed and submitted with Proposal for consideration)

1. COMPANY DETAILS

Firm's Name _____
Role on Project: _____
Telephone No. _____ Fax No. _____
Street Address _____
City _____ State _____ Zip Code _____
President _____ Vice President _____

2. COMPANY CONTACT

Name _____ Title _____

3. FORM OF BUSINESS (check one)

Sole Owner
Years in Business _____
Home Address _____

Partnership
Date of Reg. _____ in _____ County, MI. Years in Business _____
Individual Name _____
Address _____
Individual Name _____
Address _____
Individual Name _____
Address _____

Corporation
State of Registration: _____ Date of Reg. _____ Years in Business _____
Licensed to do Business in Michigan: Yes No
President's Name _____
Address _____
Vice President's Name _____
Address _____
Secretary's Name _____
Address _____
Treasurer's Name _____
Address _____

4. OTHER INTERESTS

Are there any inter-related companies, either partnerships or corporations, or other individuals who will be in any way, financial or otherwise, be involved in the Contract?

Yes No

If yes, please attach details including the name, nature of business and relationship.

Has any person named in Item 1 or 3 ever been, or still is, a principal, partner, or officer in a contracting organization in addition to the one named herein?

Yes No

If yes, please attach details including the name, position, organization name, and dates.

Did any of the above organizations ever fail to complete work or default on a contract while any person names in Items 1 or 3 was a partner or officer?

Yes No

If yes, please attach a statement as to when, where, and why, and who bonded the work.

5. NUMBER OF PERMANENT COMPANY PERSONNEL INCLUDING:

Admin:_____ Field Supervision_____ Eng. & Design_____

Normal Field Construction Workers (per week)_____ Others_____

Do you have on call capability, 24 hours a day every day?_____

6. PRESENT WORK

Do you have other work?

Yes, valued at \$_____ No

Is any of the present work behind schedule?

Yes No

If yes, please attach a statement giving reasons for delay and other pertinent data.

7. EXPERIENCE OF PRINCIPALS

Give a brief resume of the construction experience of the principals named in Items 1 or 3. A supplemental attachment is acceptable.

8. LEGAL ISSUES

Are there any judgments, claims or suits pending or outstanding against your company?

Yes No

Are you now or have you ever been involved in any bankruptcy or reorganization proceedings?

Yes No

If yes to any of the above questions, please attach details.

9. HAS YOUR COMPANY BEEN CITED BY OSHA OR EPA IN THE LAST 3 YEARS?

Yes No

If the answer is yes explain:

10. ENVIRONMENTAL, SAFETY & HEALTH POLICIES AND PROCEDURES

Do you have a documented Environmental, Safety & Health policy and program?

Yes No

Do you have a Safety Officer in your company?

Yes No

Do you employ full time safety supervision on all job sites? Yes No

Do you have a Personnel Protective Equipment (PPE) Policy or Program, for example mandatory hard, hats, safety glasses, etc.?

Yes No

Does your Safety Program address all OSHA Standards as they apply to Contractors, for example Hazardous Communication Standard (29CFR 1910.1200) and all of the required associated with said Standards?

Yes No

Comment on any other areas of your company's safety program and policies that you feel will be appropriate in our evaluation.

11. ENVIRONMENTAL, SAFETY & HEALTH TRAINING

Do you require on-site supervision to have OSHA 40 hour Training Course?

Yes No

Do you provide your own Confined Entry Rescue team trained in Tunnel Rescue?

Yes No

If no, who provides your Emergency Rescue? _____

Are your field people Certified in Confined Space Entry?

Yes No

Do you train on environmental subjects?

Yes No

Specify Topics: _____

12. **QUALITY CONTROL**

Do you have a documented Quality Control policy/program?

Yes No

SIGNATURE OF COMPANY OFFICER

Signature

Title

Date

REMINDER: Upon the request of the Owner the following documents are to be submitted within 48 hours of receipt of Notice.

1. Contractor's written safety policy.
2. List of licenses.
3. Confined Space Employee Certificates.

Past Involvement with Similar Projects

(Must be completed and submitted with Proposal for consideration)

List a minimum of three (3) contracts of similar type and size completed in the last five (5) years and provide references. Not providing these may result in disqualification of the Proposal.

Firm's Name: _____

Role on Project: _____

1. Client's Name: _____

Address: _____

Contact Name: _____ Contact Phone: _____

Type of Work: _____

Year Work Performed: _____ Work Amount (\$): _____

2. Client's Name: _____

Address: _____

Contact Name: _____ Contact Phone: _____

Type of Work: _____

Year Work Performed: _____ Work Amount (\$): _____

3. Client's Name: _____
Address: _____
Contact Name: _____ Contact Phone: _____
Type of Work: _____

Year Work Performed: _____ Work Amount (\$): _____

4. Client's Name: _____
Address: _____
Contact Name: _____ Contact Phone: _____
Type of Work: _____

Year Work Performed: _____ Work Amount (\$): _____

5. Client's Name: _____
Address: _____
Contact Name: _____ Contact Phone: _____
Type of Work: _____

Year Work Performed: _____ Work Amount (\$): _____

Fee Proposal
East Huron Street (Business I-94) Sewer Lining Project

Task 1.a: 18" Sanitary Sewer Lining \$

Task 1.b: Abandon Portion of 18" Sanitary Sewer Southeast of Manhole 71-70183 \$

Task 2: Eliminate Sanitary and Storm Cross Connection in Manhole 71-70172 and Rehabilitate the Manhole \$

Total (Numerical Value) \$

(Written Value)

THE ABOVE QUOTE IS HEREBY RESPECTFULLY SUBMITTED BY:

RESPONDENT:
a duly organized: proprietorship; partnership; or corporation authorized to do business in the project state.

By: (Signature) (Title)

By: (Print Name of Signer) (Date)

(Address) (City) (State) (Zip Code)

Telephone No.: Federal Employer ID No.

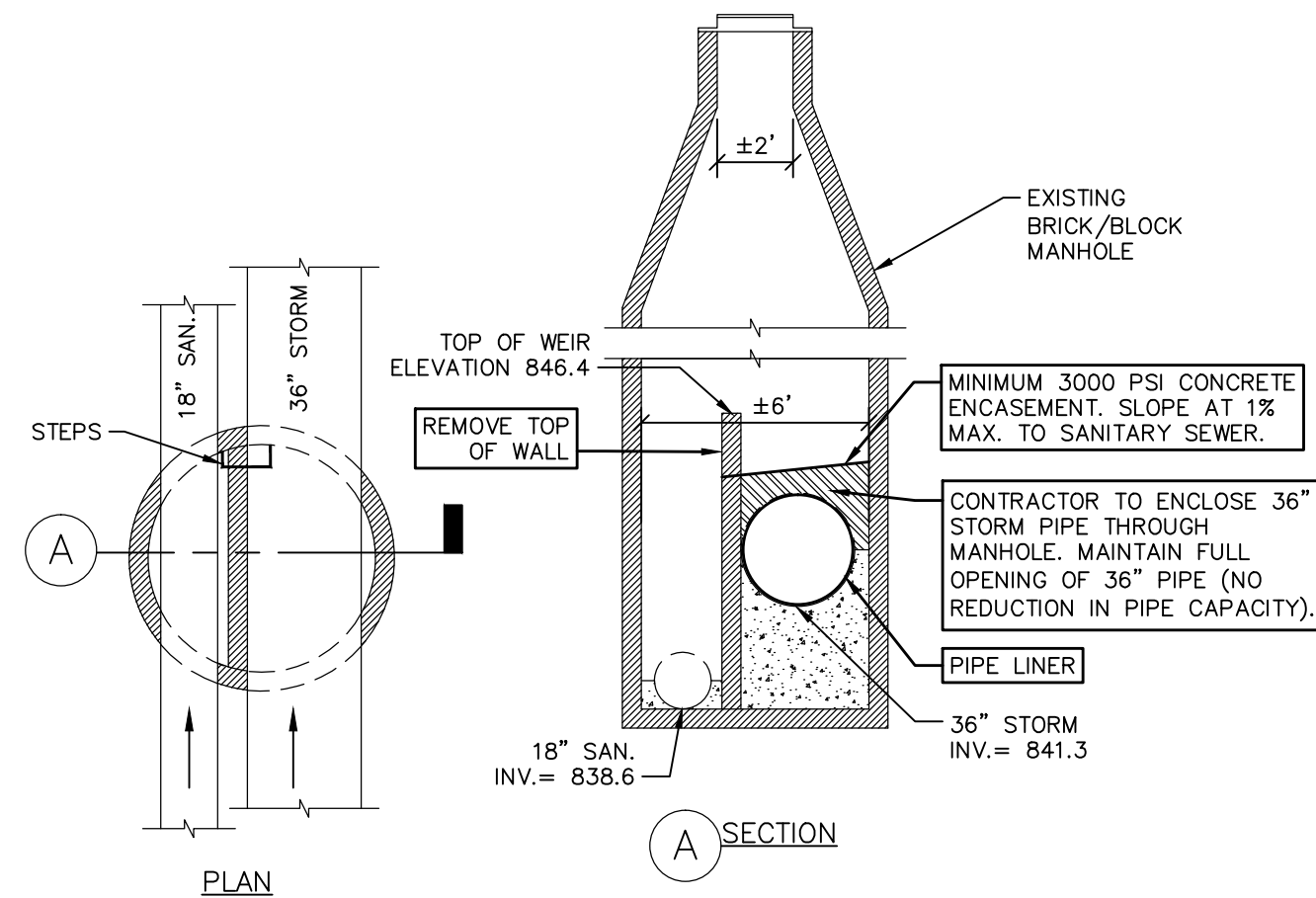

EXISTING COMBINATION STORM/ SANITARY MANHOLE 71-70172
NO SCALE

EXISTING UTILITIES

PROPOSED UTILITIES

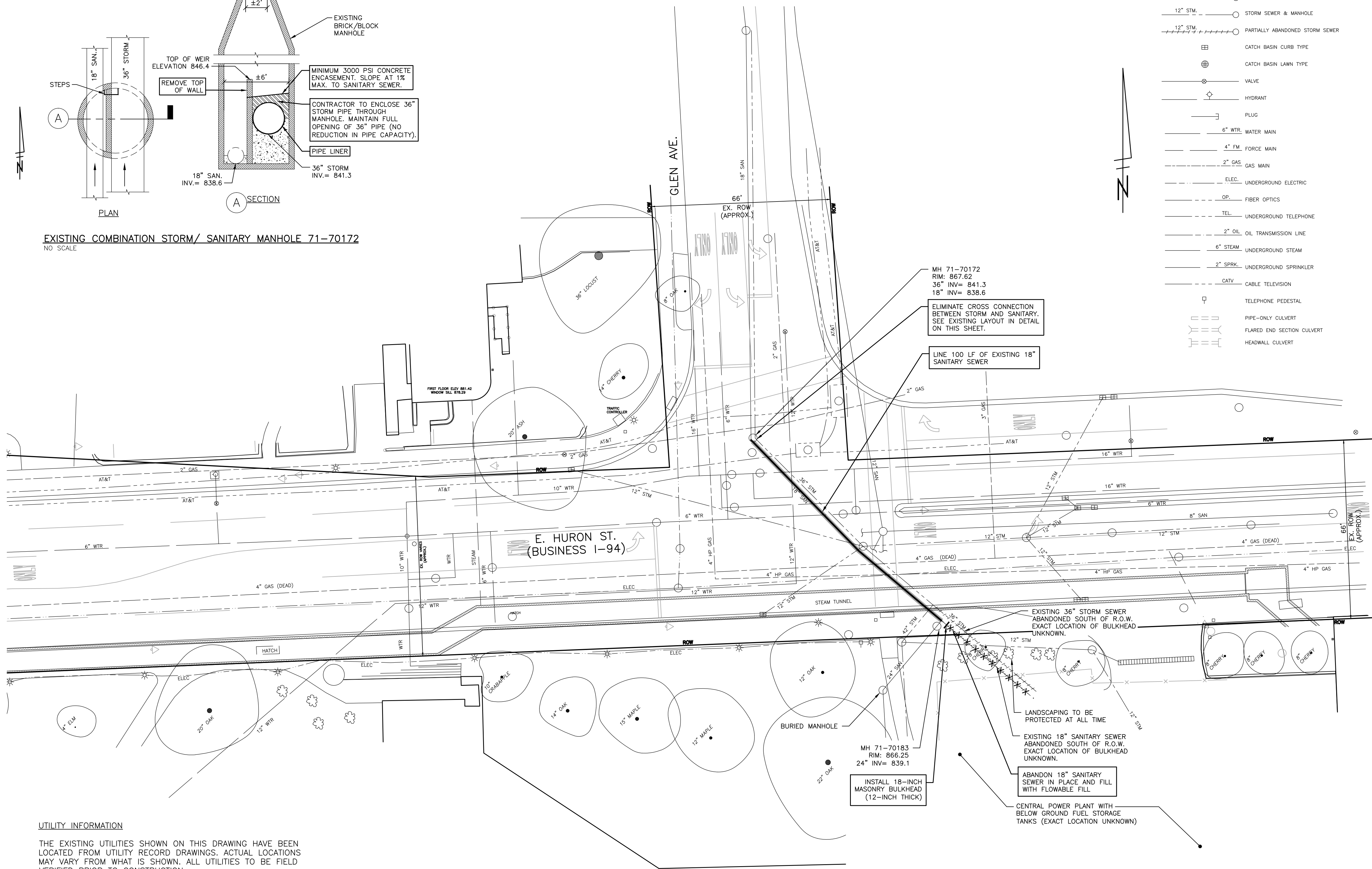
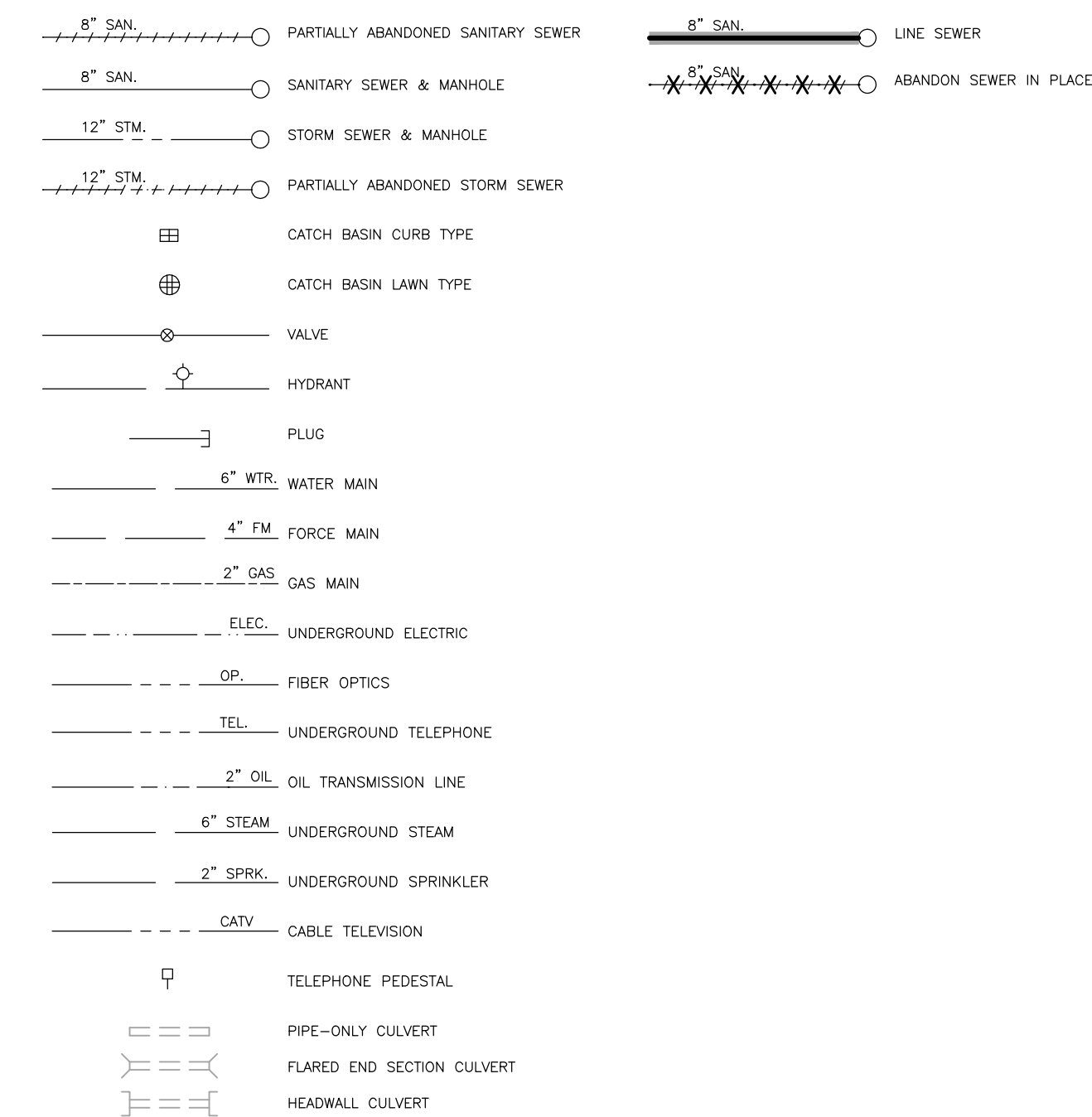

UTILITY INFORMATION

THE EXISTING UTILITIES SHOWN ON THIS DRAWING HAVE BEEN LOCATED FROM UTILITY RECORD DRAWINGS. ACTUAL LOCATIONS MAY VARY FROM WHAT IS SHOWN. ALL UTILITIES TO BE FIELD VERIFIED PRIOR TO CONSTRUCTION.



REV.	DESCRIPTION	DATE	DRAWN	CHECKED

CITY OF ANN ARBOR
PUBLIC SERVICES
301 EAST HURON STREET
ANN ARBOR, MI 48106-0667
www.a2gov.org



PROJECT MANAGEMENT - PUBLIC SERVICES - CITY OF ANN ARBOR
EAST HURON STREET (BUSINESS I-94)
SEWER LINING PROJECT
EAST HURON STREET SITE PLAN

SCALE PLAN: 1"=20'
DRAWING No.
C1-140200CD

Z:\2014\140200\CAD\C1-140200CD.dwg Dwg Created: 24-Sep-15 - standard.ctb - Plot Date: 24-Sep-15

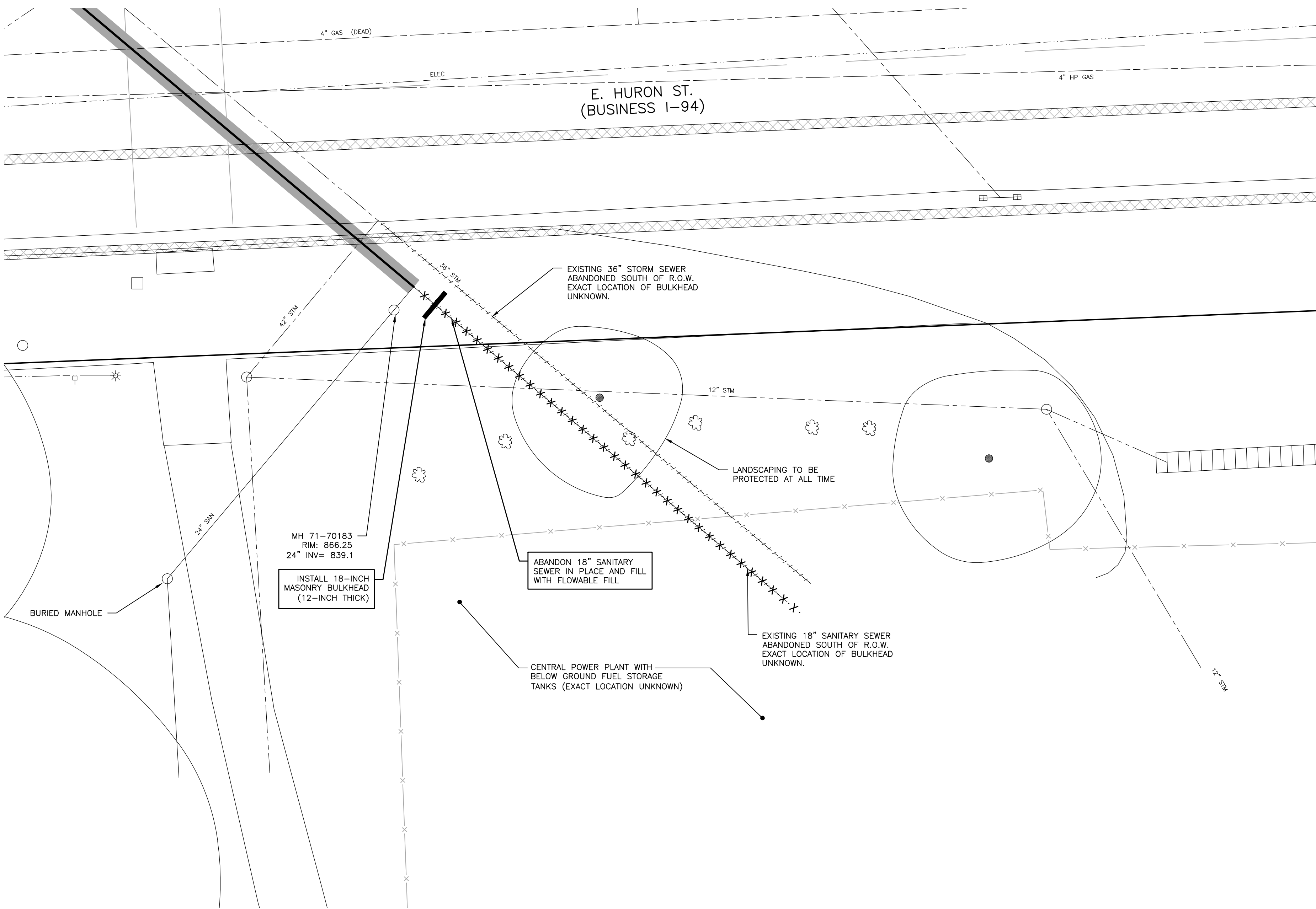

UTILITY INFORMATION

THE EXISTING UTILITIES SHOWN ON THIS DRAWING HAVE BEEN LOCATED FROM UTILITY RECORD DRAWINGS. ACTUAL LOCATIONS MAY VARY FROM WHAT IS SHOWN. ALL UTILITIES TO BE FIELD VERIFIED PRIOR TO CONSTRUCTION.

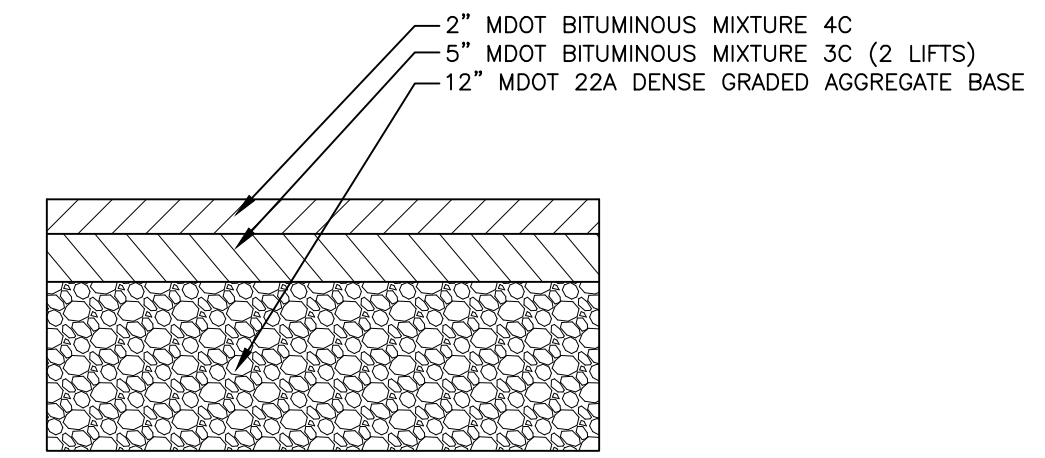

NOTE: DISTURBANCE TO THE EXISTING PAVEMENT IS NOT ANTICIPATED. HOWEVER, IF A SITUATION ARISES DURING THE WORK, THE ROAD MUST BE RESTORED IN ACCORDANCE WITH THIS DETAIL AND ALL MDOT AND CITY OF ANN ARBOR REQUIREMENTS.

ROAD SECTION
NO SCALE



- PROPOSED UTILITIES**
- 8" SAN LINE SEWER
 - 8" SAN ABANDON SEWER IN PLACE
- EXISTING UTILITIES**
- 8" SAN PARTIALLY ABANDONED SANITARY SEWER
 - 8" SAN SANITARY SEWER & MANHOLE
 - 12" STM STORM SEWER & MANHOLE
 - 12" STM PARTIALLY ABANDONED STORM SEWER
 - CATCH BASIN CURB TYPE
 - CATCH BASIN LAWN TYPE
 - VALVE
 - HYDRANT
 - PLUG
 - 6" WTR WATER MAIN
 - 4" FM FORCE MAIN
 - 2" GAS GAS MAIN
 - ELEC UNDERGROUND ELECTRIC
 - OP FIBER OPTICS
 - TEL UNDERGROUND TELEPHONE
 - 2" OIL OIL TRANSMISSION LINE
 - 6" STEAM UNDERGROUND STEAM
 - 2" SPRK UNDERGROUND SPRINKLER
 - CATV CABLE TELEVISION
 - TELEPHONE PEDESTAL
 - PIPE-ONLY CULVERT
 - FLARED END SECTION CULVERT
 - HEADWALL CULVERT

REV.	DESCRIPTION	DATE	DRAWN	CHECKED

CITY OF ANN ARBOR
PUBLIC SERVICES
301 EAST HURON STREET
ANN ARBOR, MI 48106-1410
www.a2gov.org

PROJECT MANAGEMENT - PUBLIC SERVICES - CITY OF ANN ARBOR
EAST HURON STREET (BUSINESS I-94)
SEWER LINING PROJECT
EAST HURON STREET SITE PLAN

SCALE PLAN: 1"=6'
DRAWING No. C1-140200CD
SHEET No. 2 OF 3

Z:\2014\140200\CAD\C2-140200CD.dwg Dwg Created: 14-Sep-15 - standard.ctb - Plot Date: 14-Sep-15

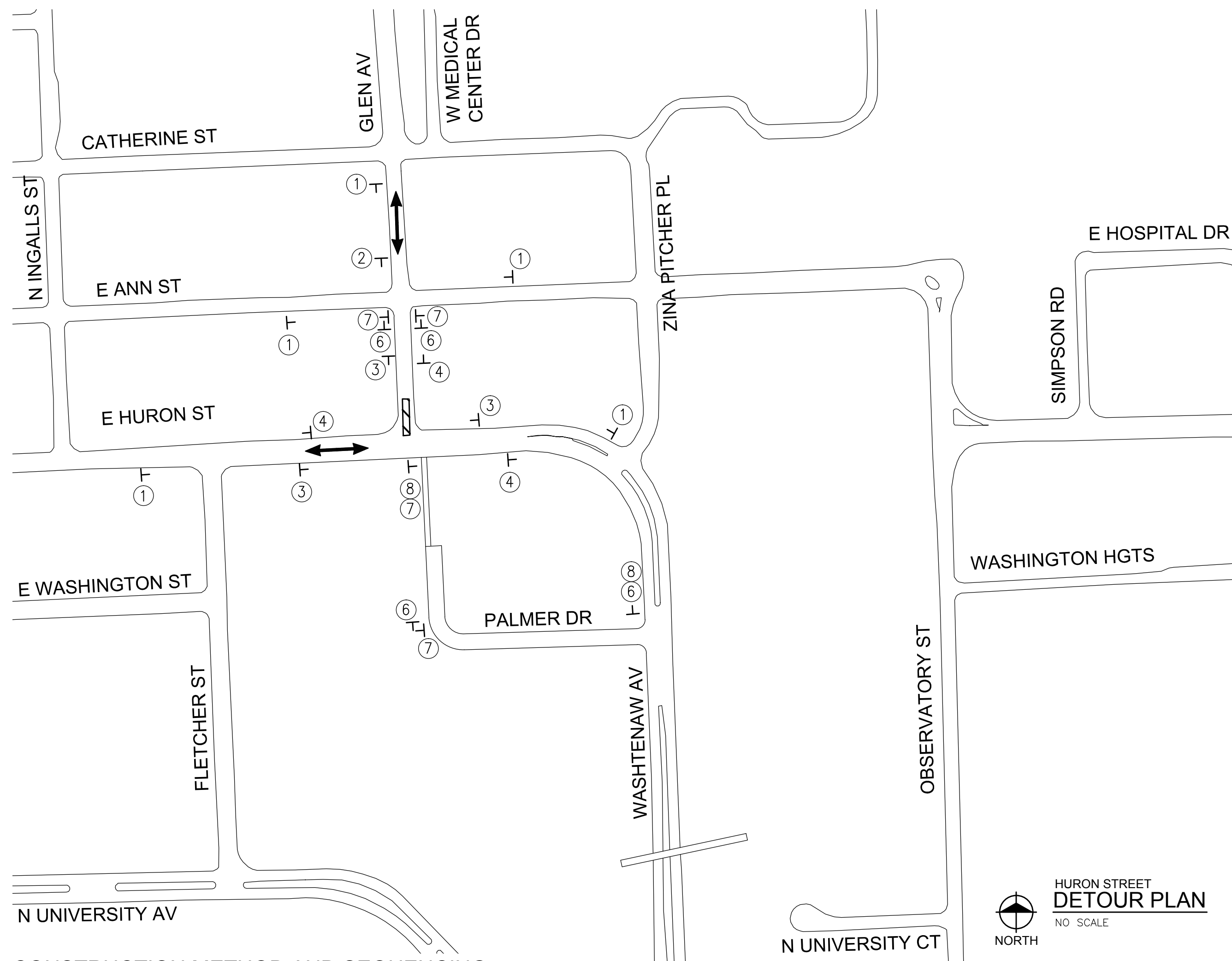

CONSTRUCTION METHOD AND SEQUENCING

IT IS THE INTENT OF THE FOLLOWING SEQUENCE OF CONSTRUCTION TO PROVIDE A WORK AREA FOR THE CONTRACTOR WHILE ALSO MAINTAINING TRAFFIC IN A MANNER WHICH IS SAFE FOR THE TRAVELING PUBLIC. IT IS THE RESPONSIBILITY OF THE CONTRACTOR TO COORDINATE, SCHEDULE, AND OVERSEE ALL UTILITY RELOCATIONS AND ADJUSTMENTS. THE CONTRACTOR SHALL ACCOUNT FOR ALL SUCH EFFORT IN THE CONSTRUCTION SCHEDULE. ALL TEMPORARY OR PERMANENT PAVEMENT MARKINGS AND SIGNING SHALL BE IN PLACE BEFORE ANY PAVEMENT IS OPENED TO TRAFFIC. THE WORK TO BE COMPLETED ON THIS STREET SHALL INCLUDE, BUT NOT BE LIMITED TO THE FOLLOWING ITEMS. THE ORDER OF CONSTRUCTION SHALL BE AS GIVEN UNLESS OTHERWISE AUTHORIZED OR DIRECTED BY THE ENGINEER.

1. IMPLEMENT TRAFFIC MAINTENANCE, AND SOIL EROSION CONTROLS IN ACCORDANCE WITH THE PLANS, AND AS DIRECTED BY THE ENGINEER. INSTALL PEDESTRIAN DETOUR SIGNS PER PLAN. PEDESTRIANS ARE DETOURED TO ANN STREET CROSSWALK AND TO PALMER DRIVE.
2. PERFORM ALL REMOVALS, SEWER IMPROVEMENTS AND RESTORATIONS TO ALLOW ACCESS TO PROPERTIES ON HURON STREET AND GLEN AVENUE.
3. COMPLETE ALL MISCELLANEOUS CONSTRUCTION ITEMS, INCLUDING CLEAN-UP AND FINAL RESTORATION.
4. REMOVE ALL TRAFFIC CONTROL DEVICES. REMOVE MISS DIG FLAGS.

TRAFFIC CONTROLS

1. THE NECESSARY SIGNS AND SIGN SUPPORT STANDARDS, BARRICADES, AND TRAFFIC CONTROL DEVICES NECESSARY FOR THE PROTECTION OF TRAFFIC SHALL BE IN ACCORDANCE WITH MICHIGAN MANUAL ON UNIFORM TRAFFIC CONTROL DEVICES AS APPROVED BY THE CITY OF ANN ARBOR AND MDOT. ALL SUCH DEVICES SHALL BE FURNISHED, INSTALLED, AND MAINTAINED BY THE CONTRACTOR.
2. REFER TO CITY SPECIFICATIONS AND MDOT PERMIT FOR DETAILS ON MATERIALS, EQUIPMENT, AND CONSTRUCTION METHODS.
3. ALL POSTS TO BE DRIVEN INTO GROUND.
4. CONTRACTOR TO FIELD STAKE ALL SIGNS AND CONTACT CITY FOR REVIEW AND APPROVAL OF SIGN PLACEMENT PRIOR TO INSTALLATION.
5. ACCESS TO DRIVEWAYS AND CROSS ROADS MUST BE MAINTAINED AT ALL TIME. 2 DAYS NOTICE MUST BE PROVIDED BEFORE TEMPORARY CLOSURES.
6. COORDINATE SIGNAL PHASING AND TIMING WITH THE CITY OF ANN ARBOR AND MDOT.

LEGEND

- WORK ZONE
- DIRECTION OF ONE-WAY TRAFFIC
- TWO-WAY TRAFFIC
- TYPE III BARRICADE
- 42" CHANNELLING DEVICES AT 50' CENTER ON TANGENTS AND 25' ON TAPERS
- TEMP CONSTRUCTION SIGN
- LIGHTED ARROW PANEL (CAUTION MODE)

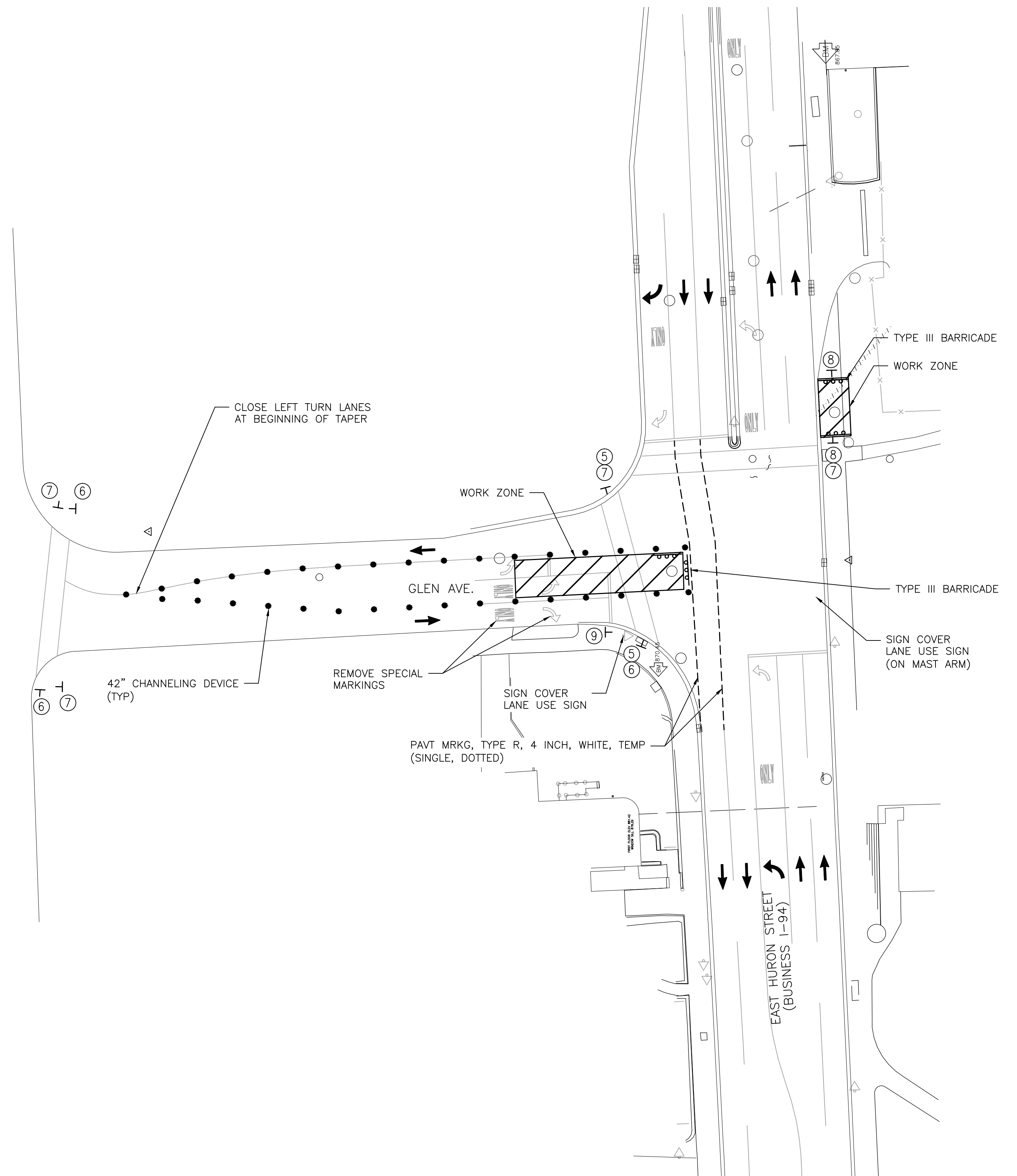
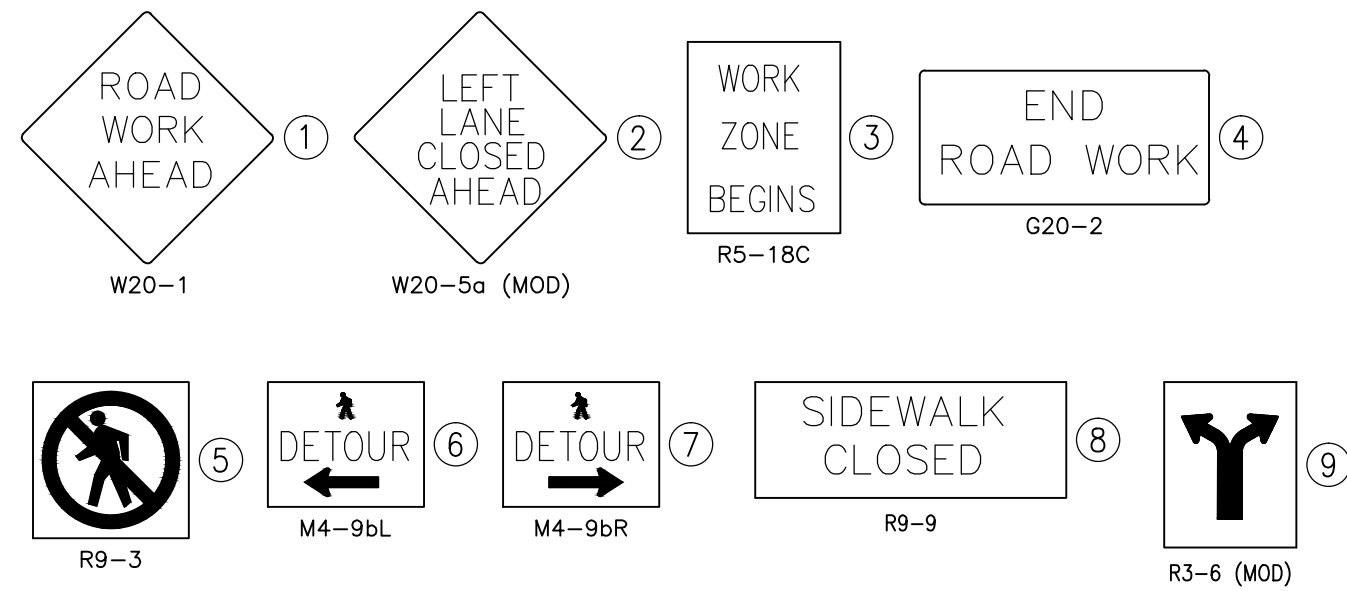

REV.	DESCRIPTION	DATE	DRAWN	CHECKED

CITY OF ANN ARBOR
PUBLIC SERVICE
301 EAST HURON STREET
ANN ARBOR, MI 48106-1667
www.a2gov.org

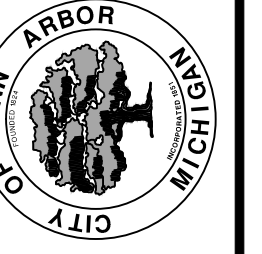

PROJECT MANAGEMENT - PUBLIC SERVICES - CITY OF ANN ARBOR
EAST HURON STREET (BUSINESS I-94)
SEWER LINING PROJECT
MINIMUM TRAFFIC CONTROL REQUIREMENTS

SHEET No. **C2-140200CD**