



## CITY OF ANN ARBOR, MICHIGAN

Project Management Services Unit  
100 North Fifth Ave.  
P.O. Box 8647, Ann Arbor, Michigan 48107  
Phone: (734) 994-2744 Fax: (734) 994-1744  
Web: [www.a2gov.org](http://www.a2gov.org)

June 2, 2008

Subject: City Requirements Concerning Public Sidewalk and Drive Approach Construction

Ladies and Gentlemen:

Attached is an information packet which has been created from various sources concerning public sidewalk and drive approach construction in the City of Ann Arbor. This information includes an excerpt from Chapter 47 of the City Code of Ordinances, and certain standard details and text excerpts from the Public Services Department Standard Specifications relating to this type of work.

This packet is meant to provide an overview of highlighted requirements for this type of construction. **All** City requirements must be followed. The omission of any requirement does not relieve the contractor from constructing the work in complete conformance to the Public Services Department Standard Specifications. Copies of the Standard Specifications may be purchased from the Project Management Services Unit during regular business hours. The cost of the book and disk is \$35.00 and \$15.00 per copy, respectively, which includes the mailing of any updates to all registered book and disk holders. The Public Services Department Standard Specifications are also available at no cost on the Private Development webpage at:

[www.a2gov.org/government/publicservices/project\\_management/privatedev](http://www.a2gov.org/government/publicservices/project_management/privatedev)

As we are unable to track those who receive this information packet, and as this information included in the packet is subject to revision and updating, the contractor is responsible for verifying that the most current standard details are followed.

Very truly yours,  
PUBLIC SERVICES AREA

Homayoon Pirooz, P.E.  
Project Management Manager

attachment

SECTIONS PERTAINING TO CHAPTER 47 OF TITLE IV OF THE CODE OF THE  
CITY OF ANN ARBOR AS PASSED BY CITY COUNCIL AUGUST 2, 1976

The City of Ann Arbor Ordains:

Section 1. That Chapter 47 of the City Code be amended by adding Sections 4:17 and 4:19 and that Section 4:18 of the Code of the City of Ann Arbor be amended to read as follows:

CURB CUTS AND DRIVEWAY APPROACHES

4:17. Compliance with Chapter 57. No site plan shall be approved under Chapter 57 of this Code unless said site plan shows curb cuts or openings consistent with the requirements of this Chapter.

4:18. Compliance with Chapter Required for Occupancy. No certificate of occupancy for any building will be issued under Chapter 98 of this Code unless the applicant for said certification shall have complied substantially with the requirements of this Chapter and related land development regulations and have substantially completed the installation of curb cuts contained in any plat or site plan approved for said applicant.

4:19. Non-Conforming Curb Cuts. Curb cuts lawfully made prior to the effective date of this ordinance which do not meet the standards of this ordinance shall be considered non-conforming but may be maintained except as provided in Section 4:20 (6), (8) and (9) of this ordinance.

4:20 Curb Cuts And Driveway Approaches. No curb cut or driveway approach shall be made to a public dedicated street or right-of-way without first obtaining a permit from the City Administrator or his designee. Issuance of such permits shall be made only in accordance with the following regulations:

- (1) Definitions. As used in this section, the following definitions apply:
  - (a) The term "approach" shall mean an area improved for vehicular traffic on a public street right-of-way which connects the traveled portion of the street with a driveway.
  - (b) The term "curb cut" shall mean that section of curb removed to permit ingress from the pavement to the adjacent property and shall be measured between the points of tangency of the opening radii with the normal street curbing.
  - (c) The term "opening" shall mean the point of connection of the driveway and approach at the street right-of-way line. Its width and location shall be determined by extending the driveway line to the street right-of-way line.

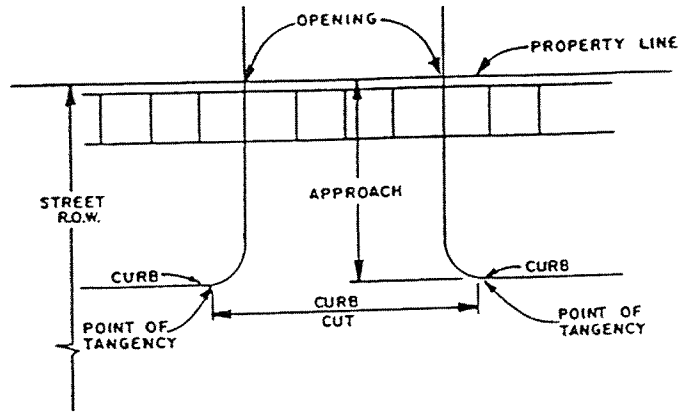

- (d) The term "site" shall mean all contiguous land under the same ownership or one whole lot in the case of land for which a recorded plat exists.
- (e) "Street frontage" shall mean the length of the property abutting one or more streets.

(2) Number of Openings. The number of openings listed in the charts below shall be maximum for any site, lot or parcel.

Total Street Frontage	Up To 100'	101' To 200'	201' Or Over
Number of Openings	(1)	(2)	(2) for the first 200' plus (1) for each additional 600' of total street frontage thereafter.

(3) Location of Openings.

- (a) No opening shall be closer than fifteen (15) feet to the right-of-way line of an intersecting street or extension of the street right-of-way of a street ending at the intersection, provided that no part of any approach shall encroach on any intersection turning area, except as required in Subsection 5 of this ordinance.

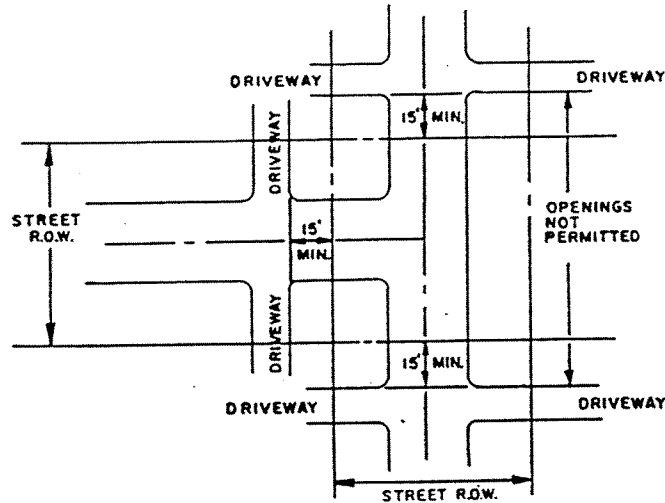

- (b) No opening shall be closer than ten (10) feet from the right-of-way line of an alley, except in the case of a joint approach and provided the total width of the combined opening does not exceed that permitted in Subsection (4) of this ordinance.
- (c) No opening shall be closer than four and one-half (4½) feet to the adjacent property line. No approach shall be so constructed that any part of same extends in front of property belonging to another person unless both property owners sign a joint application for a permit.
- (d) Any two (2) openings shall be at least nine (9) feet apart; provided that this requirement shall not apply to openings for existing driveways on residential property.

- (e) All openings and approaches shall be so located as to provide adequate vertical and horizontal sight distances for safe access to the street in accordance with the Design Standards for sight distance, copies of which are on file with the Department of Streets, Traffic and Parking.
  
- (4) Design Criteria.
  - (a) The angle of the driveway approach to the street shall be ninety degrees, except as otherwise provided for herein.
  
  - (b) Driveways for single and two family uses shall be constructed as follows:
    - (i) Minimum permitted width of openings: 10 feet.
    - (ii) Maximum permitted width of openings: 24 feet.
    - (iii) Maximum permitted curb cut width: 44 feet.
    - (iv) Minimum turning radius: 5 feet
  
  - (c) Driveways for all other uses shall be constructed as follows:
    - (i) Minimum permitted width of openings: 24 feet
    - (ii) Maximum permitted width of openings: 30 feet
    - (iii) Maximum permitted curb cut width: 60 feet.
    - (iv) Minimum permitted width of one-way drives: 15 feet
    - (v) Maximum permitted width of one-way drives: 20 feet.
    - (vi) Minimum turning radius at pavement edge: 5 feet.
    - (vii) Maximum turning radius at pavement edge: 15 feet
  
  - (d) Upon a finding that traffic conditions would otherwise cause unnecessary congestion or practical difficulties, the City Administrator or his designee may permit the following design features.
    - (i) One of the driveway openings on each abutting street may be channelized with a separating island a minimum of ten (10) feet in width to form a separate opening for entrance and exit lanes; provided that the total of both lanes shall not exceed the maximum permitted width.
  
- (5) Standards for Parking Lots. The following requirements shall apply to parking lots having more than four (4) car spaces:

- (a) The minimum distance to intersections as measured from the extension of the street right-of-way line to the nearest edge of the driveway opening shall be fifty (50) feet.
  - (b) Where two or more openings are permitted, signs shall be erected, making one or more openings one-way.
  - (c) No opening shall be so located as to conflict with an existing opening on the opposite side of the street.
- (6) **Traffic Hazards.** Any openings which are found to be a traffic hazard may be closed, modified, or relocated by resolution of City Council.
- (7) **Traffic Control Order.** The direction and turning movement of traffic entering and exiting through openings shall be subject to traffic control orders issued pursuant to Chapter 126 of Title X of this Code.
- (8) **Useless Curb Cuts.** If at any time a curb cut ceases to be functional, the curb shall be replaced and the approach removed by the adjoining property owner. No building permit shall be issued pursuant to Chapter 98 of this Code where, as a result of the construction, a curb cut would become nonfunctional, unless said permit provides for the replacement of the curb and removal of the approach. If a useless curb is not replaced by curbing and the approach removed, said work may be done by the City. The cost of said work shall be assessed in accordance with Chapter 13 of this Code against the site formerly served by the curb cut.
- (9) **Variance and Exceptions.** The Zoning Board of Appeals shall have the authority to interpret this Chapter and may, in specific cases involving practical difficulty or unnecessary hardship, grant variances or exceptions from the requirements of this Chapter providing such variance or exception is in harmony with the general purpose and intent of this Chapter. Appeals under this Chapter shall be made in accordance with procedures outlined under Sections 5:99 and 5:102 of Chapter 55.

Section 2. That Sections 4:20 and 4:21 of Chapter 47 of Title IV of the City Code be renumbered as Section 4:21 and 4:22, respectively.

Section 3. That this ordinance shall take effect ten (10) days after publication.

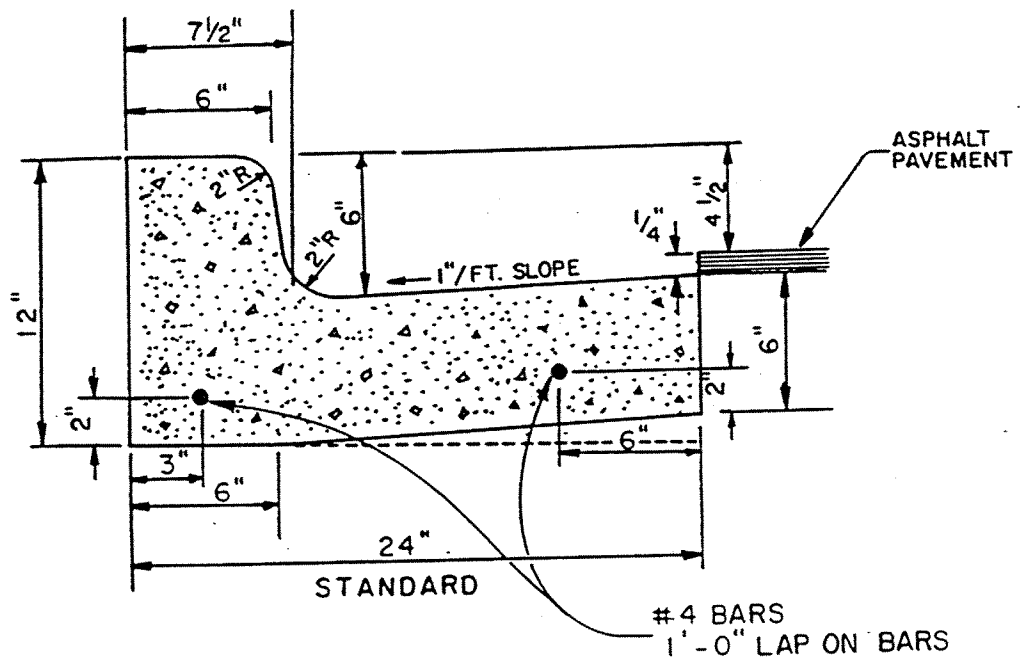

REVISION		1		
REVISIONS	REV. NO.	DR. BY	CH. BY	DATE
PUBLIC SERVICES DEPARTMENT CITY OF ANN ARBOR				
BARRIER CURB AND GUTTER				
DR. BY	D.F.	CH. BY	C.S.S.	DRAWING NO.
SCALE	NONE	DATE	11-6-92	SD-R-1
INCH				SHEET NO. _____ OF _____

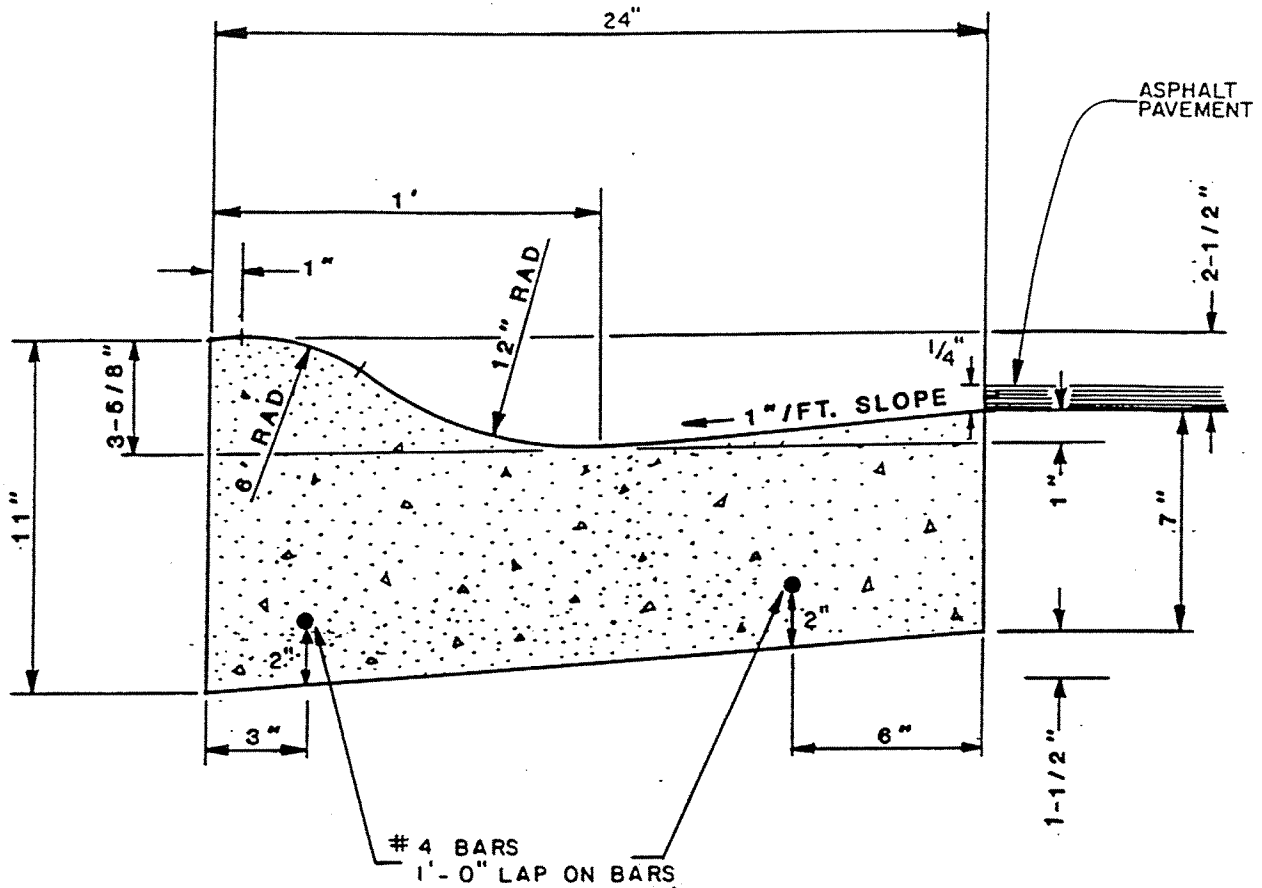

NOTE: FRONT EDGE OF  
INLET CASTINGS  
SHALL BE FLUSH  
WITH FRONT  
EDGE OF GUTTER  
(EDGE-OF-METAL)

REVISION	I			
REVISIONS	REV. NO.	DR. BY	CH. BY	DATE
PUBLIC SERVICES DEPARTMENT CITY OF ANN ARBOR				
MOUNTABLE CURB & GUTTER				
DR. BY D.F.	CH. BY C.S.S.	DRAWING NO.		
SCALE NONE	DATE 11-6-92	SD-R-2		
INCH		SHEET NO. _____ OF _____		



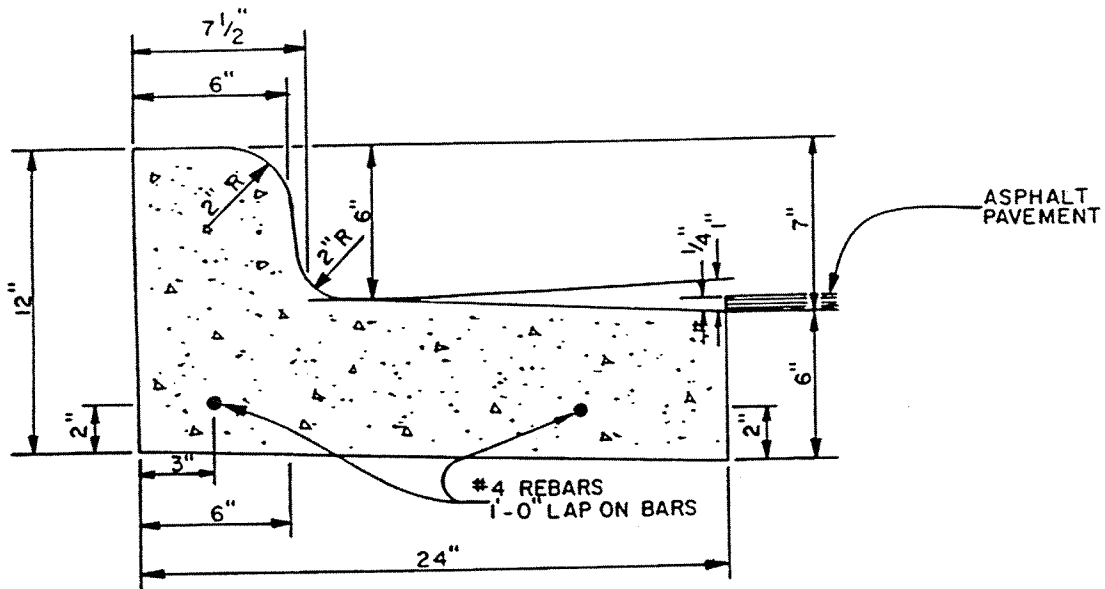

REVISION		1		
REVISIONS	REV. NO.	DR. BY	CH. BY	DATE
PUBLIC SERVICES DEPARTMENT CITY OF ANN ARBOR				
SPILL-OUT BARRIER CURB & GUTTER				
DR. BY	D.F.	CH. BY	C.S.S.	DRAWING NO.
SCALE	NONE	DATE	11-6-92	SD-R-3
INCH				SHEET NO. _____ OF _____

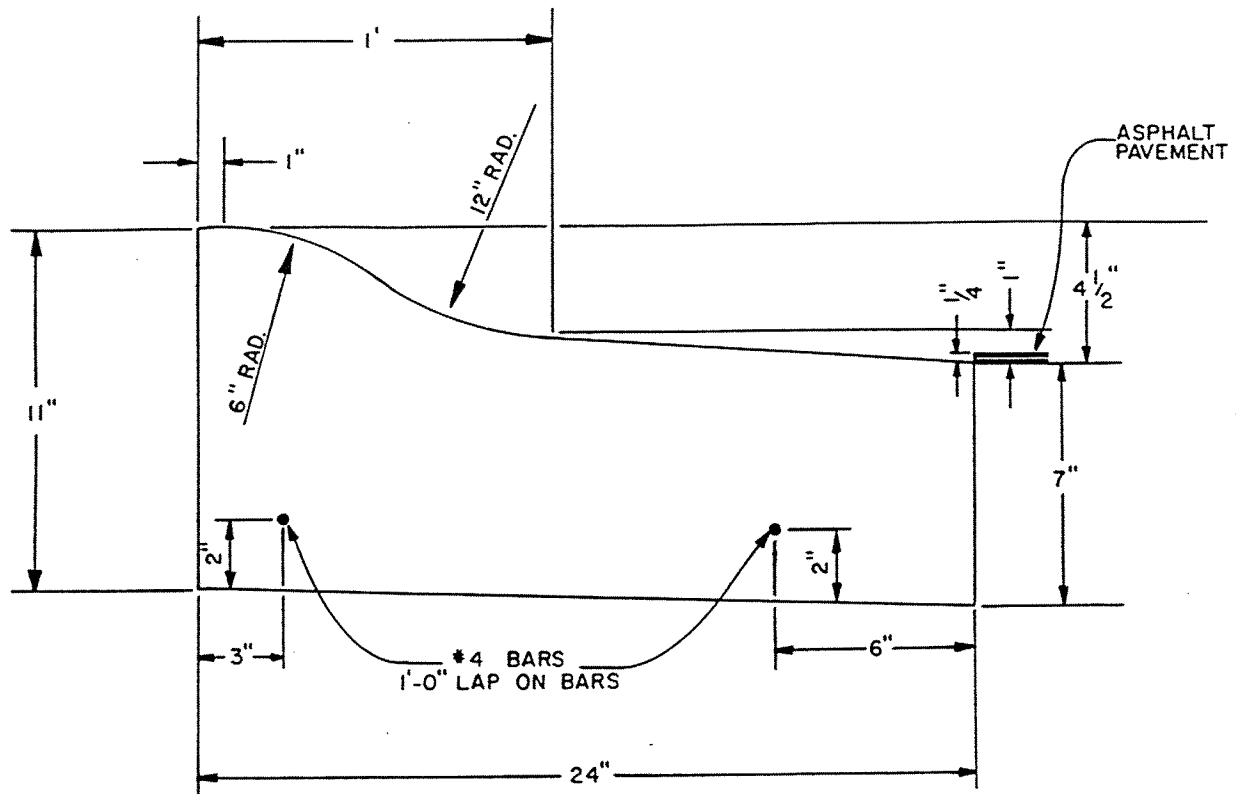

REVISION		1			
REVISIONS	REV. NO.	DR. BY	CH. BY	DATE	
PUBLIC SERVICES DEPARTMENT CITY OF ANN ARBOR					
SPILL-OUT MOUNTABLE CURB & GUTTER					
DR. BY	D.F.	CH. BY	C.S.S.	DRAWING NO.	
SCALE	NONE	DATE	11-6-92	SD - R - 4	
INCH			SHEET NO. _____ OF _____		

THREAD AND OVERALL LENGTH SHALL BE AS GOVERNED BY TYPE AND SIZE OF ANCHOR USED. NOTE THAT RECESSED ANCHOR REQUIRES LONGER BOLT TO MEET MINIMUM EMBEDMENT. (FLUSH TYPE ANCHOR SHOWN)

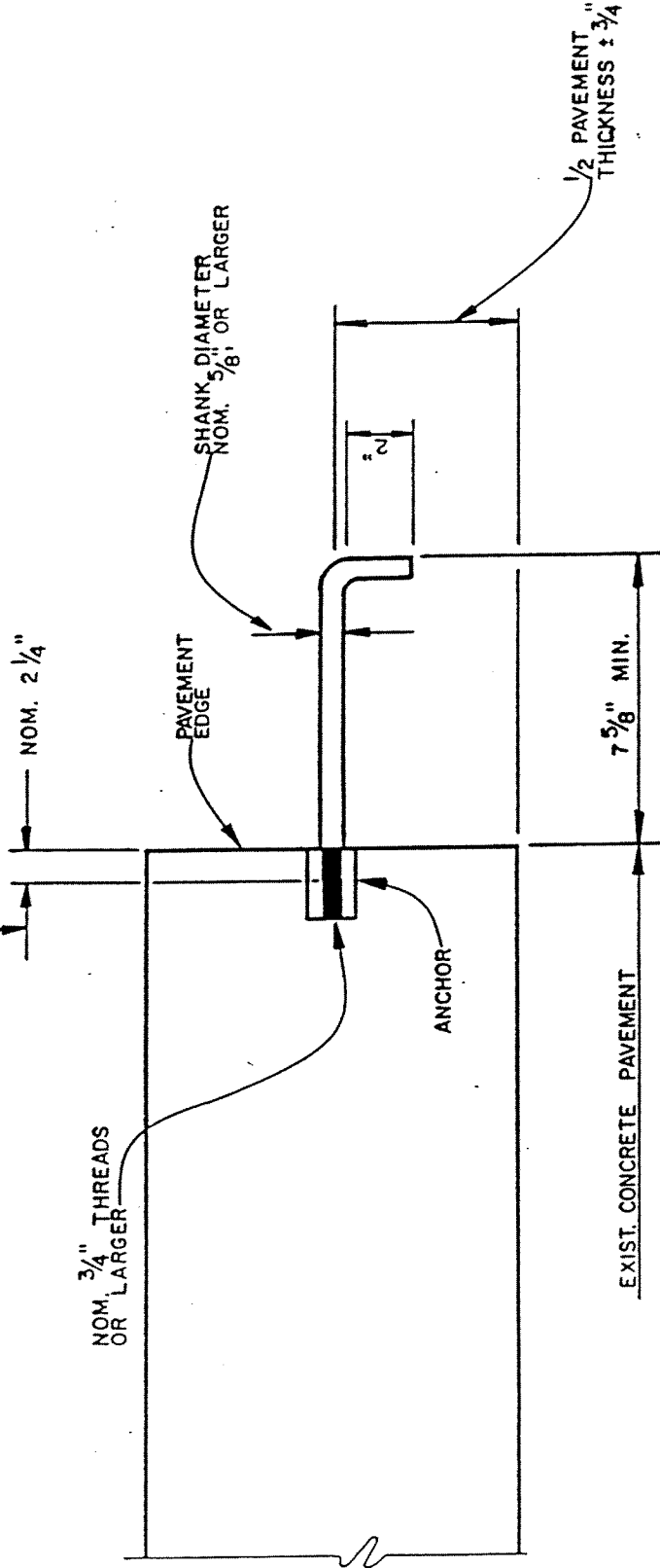

HOOK BOLTS SHALL BE 12" C-C

REVISION	1			
REVISIONS	REV. NO.	DR. BY	CH. BY	DATE
PUBLIC SERVICES DEPARTMENT CITY OF ANN ARBOR				
<b>MECHANICAL ANCHOR AND HOOK BOLT</b>				
DR. BY	D. F.	CH. BY	C. S. S.	DRAWING NO.
SCALE	NONE	DATE	11-6-92	<b>SD-R-5</b>
INCH	$\frac{1}{4}$			SHEET NO. <u>    </u> OF <u>    </u>

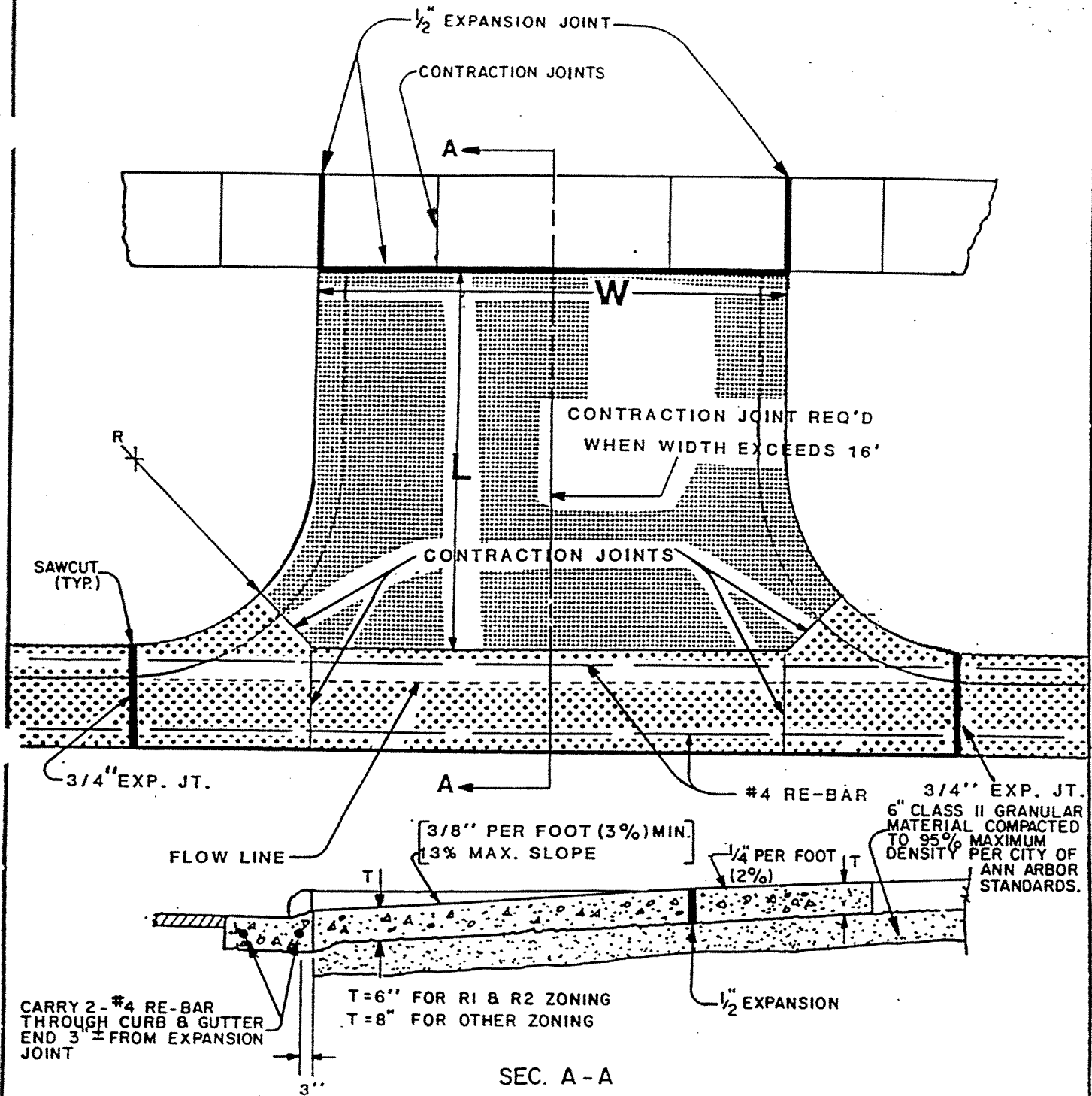

**MEASUREMENT OF AREA**

$W \times L = \text{AREA}$

- NOTE: DRIVE APPROACH TO BE CLASS 'A' CONCRETE
- NOTE: R (RADIUS) AND W (DRIVE WIDTH) AS REQUIRED FOR ZONING BY CITY CODE
- NOTE: IF GUTTER IS OVERLAYED, GUTTER OF THE APPROACH SHALL BE AT SAME ELEVATION AS EXISTING GUTTER, AND ASPHALT WEDGE SHALL BE PLACED IN THE APPROACH.

S/W GRADE REVISED	I	NCF	CSS	1-31-94
REVISIONS	REV. NO.	DR. BY	CH. BY	DATE
PUBLIC SERVICES DEPARTMENT CITY OF ANN ARBOR				
TYPE 'M' DRIVE APPROACH (FOR USE ON ASPHALT STREETS WITH BARRIER CURB)				
DR. BY D.F.	CH. BY C.S.S.	DRAWING NO.		
SCALE NONE	DATE 11-6-92	SD - R - 6		
INCH		SHEET NO. _____ OF _____		

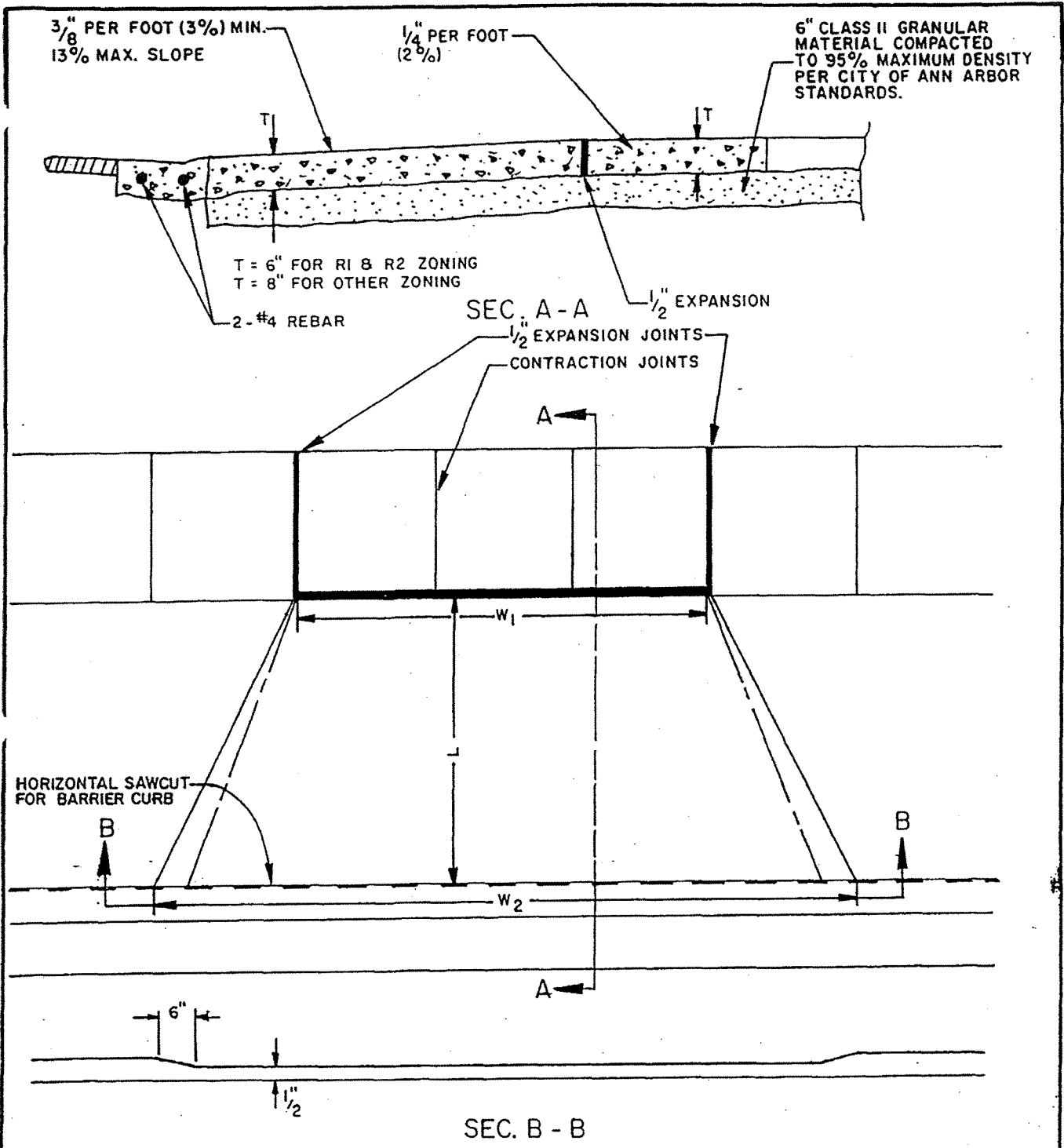

NOTE: W<sub>1</sub> (DRIVE OPENING WIDTH) AND W<sub>2</sub> (CURB CUT WIDTH) AS REQUIRED FOR ZONING BY CITY CODE.

MEASUREMENT OF AREA:  
 $\frac{1}{2}(W_1 + W_2) \times L = \text{AREA}$

NOTE: DRIVE APPROACH TO BE CLASS 'A' CONCRETE

SEC. B-B; S/W GRADE	I	DPF	CSS	1-31-94
REVISIONS	REV. NO.	DR. BY	CH. BY	DATE
PUBLIC SERVICES DEPARTMENT CITY OF ANN ARBOR				
TYPE 'L' DRIVE APPROACH (FOR USE ON STREETS WITH BARRIER OR MOUNTABLE CURB)				
DR. BY	D.P.F.	CH. BY	C.S.S.	DRAWING NO.
SCALE	NONE	DATE	11-6-92	SD-R-7
INCH				SHEET NO. _____ OF _____

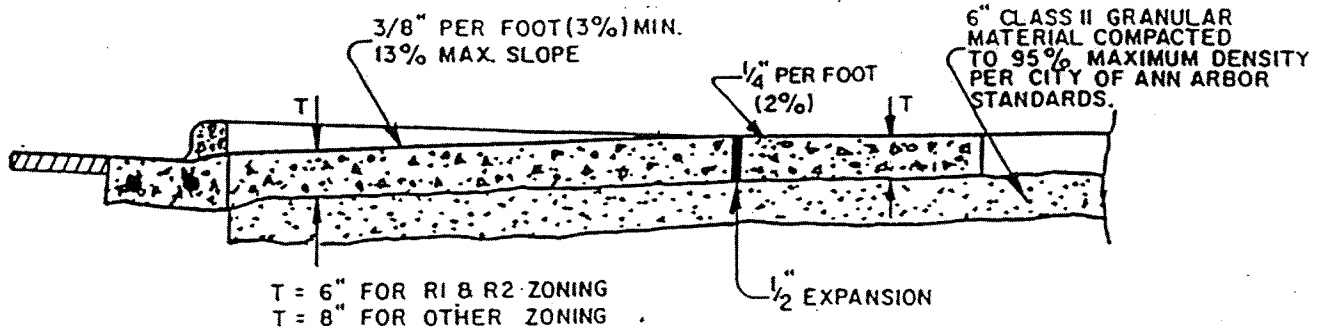

SEC. A-A

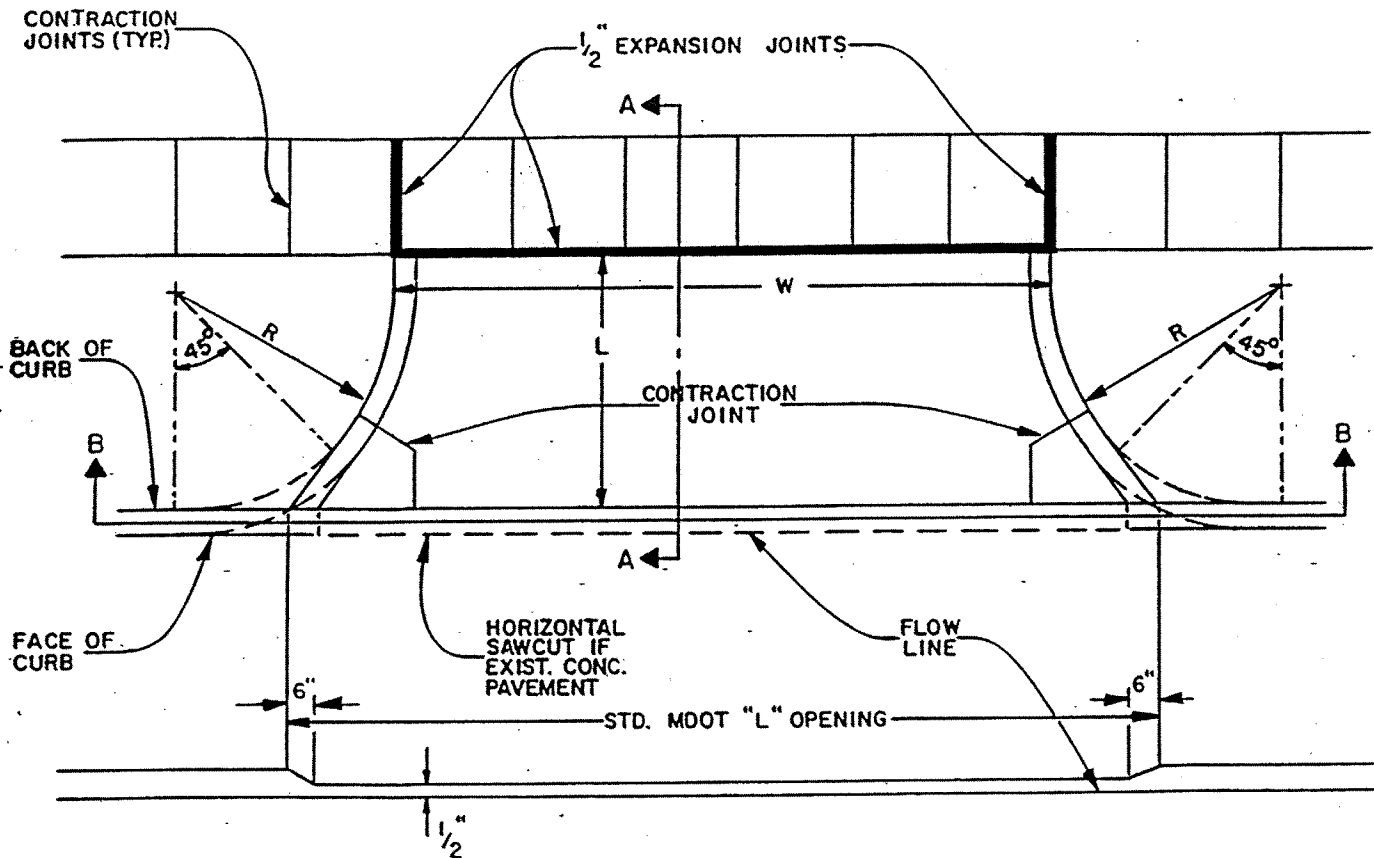

SEC. B-B

NOTE: R (RADIUS) AND W (DRIVE WIDTH) AS REQUIRED FOR ZONING BY CITY CODE.

NOTE: DRIVE APPROACH TO BE CLASS 'A' CONCRETE.

MEASUREMENT OF AREA:

$W \times L = \text{AREA}$

S/W GRADE; SEC. B-B DIMENSIONS	I	NCF	CSS	1-31-94
REVISIONS	REV. NO.	DR. BY	CH. BY	DATE
PUBLIC SERVICES DEPARTMENT CITY OF ANN ARBOR				
MODIFIED 'M' DRIVE APPROACH (FOR USE ON CONCRETE STREETS WITH BARRIER CURB)				
DR. BY	D.F.	CH. BY	C.S.S.	DRAWING NO.
SCALE	NONE	DATE	11-6-92	SD-R-8
INCH				SHEET NO. _____ OF _____

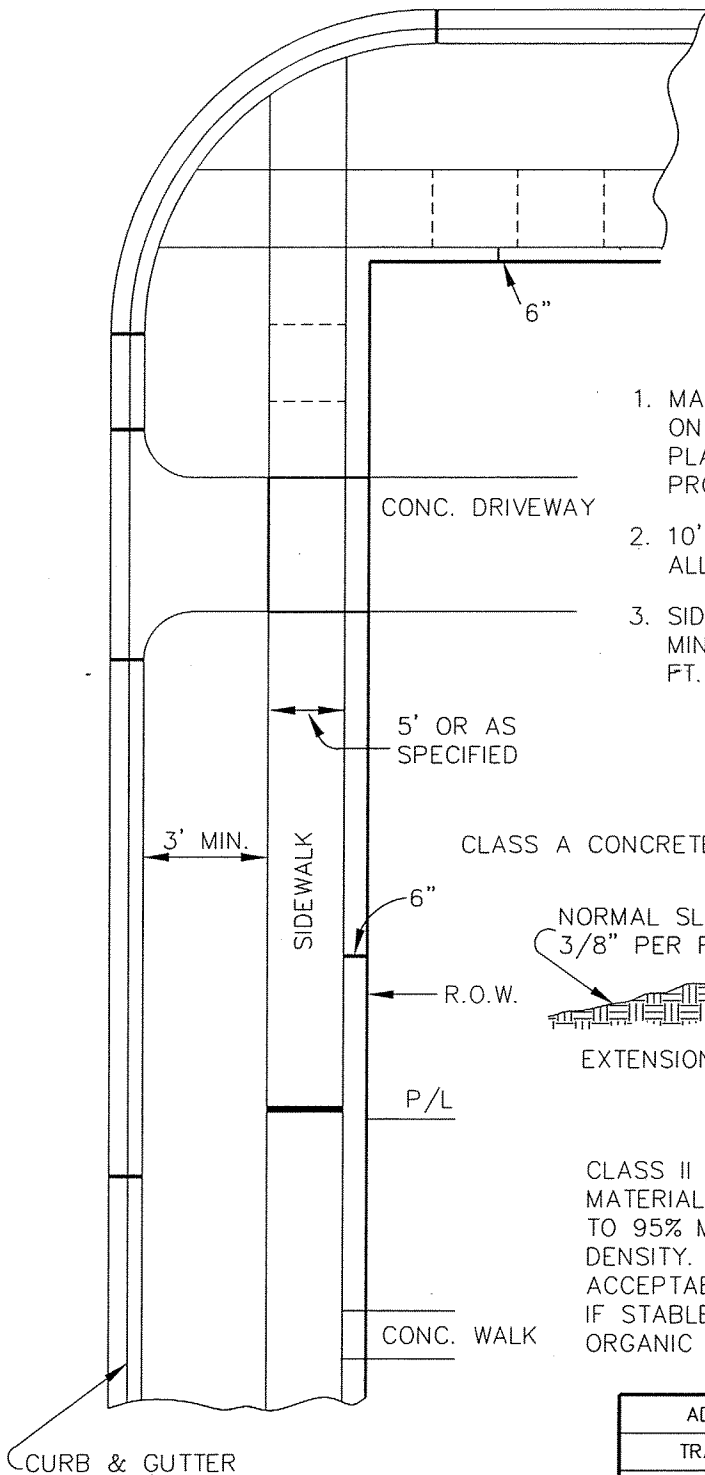

1. MAX. 300' SPACING BETWEEN ALL EXPANSION JOINTS. ON CURB AND GUTTER. EXPANSION JOINTS TO BE PLACED IN SIDEWALKS AT THE EXTENSION OF ALL PROPERTY LINES.
2. 10' NORMAL, 8' MIN. SPACING BETWEEN ALL CURB CONTRACTION JOINTS.
3. SIDEWALK CONTRACTION JOINT SPACING IS 5' MIN. AREA 16 SQ. FT., MAX. AREA 36 SQ. FT.

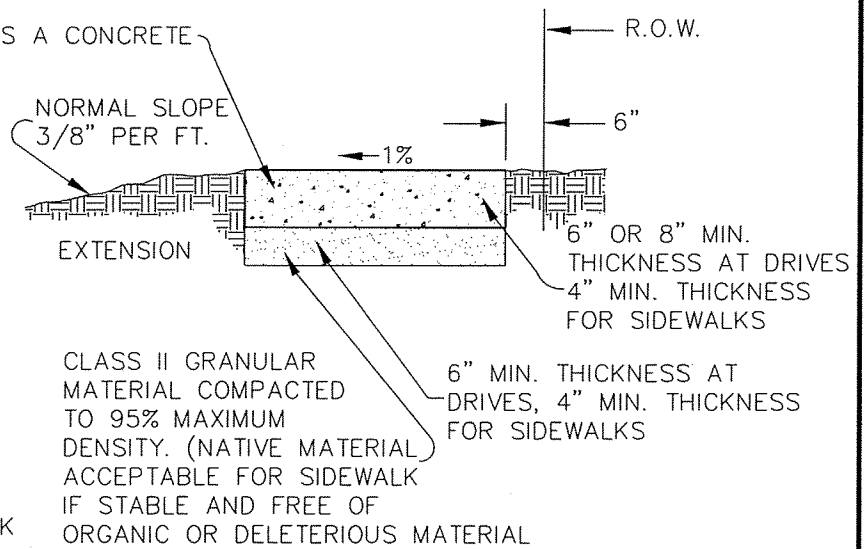

**LEGEND:**

CONTRACTION JOINTS	-----
1/2" EXPANSION JOINTS	————
3/4" EXPANSION JOINTS	————

ADA COMPLIANCE REVS.	2	DPF	TB/DC/MGN	
TRANSVERSE GRADE REV.	1	NCF	CSS	1-31-94
<b>REVISIONS</b>	<b>REV. NO.</b>	<b>DR. BY</b>	<b>CH. BY</b>	<b>DATE</b>

**PUBLIC SERVICES AREA  
CITY OF ANN ARBOR**

**SIDEWALK & CURB & GUTTER JOINTS**

<b>DR. BY</b>	DPE	<b>CH. BY</b>	CSS	<b>DRAWING NO.</b>	SD-R-9
<b>SCALE</b>	NONE	<b>DATE</b>	11-6-92		
<b>INCH</b>	0 1			<b>SHEET NO.</b>	1 OF 1

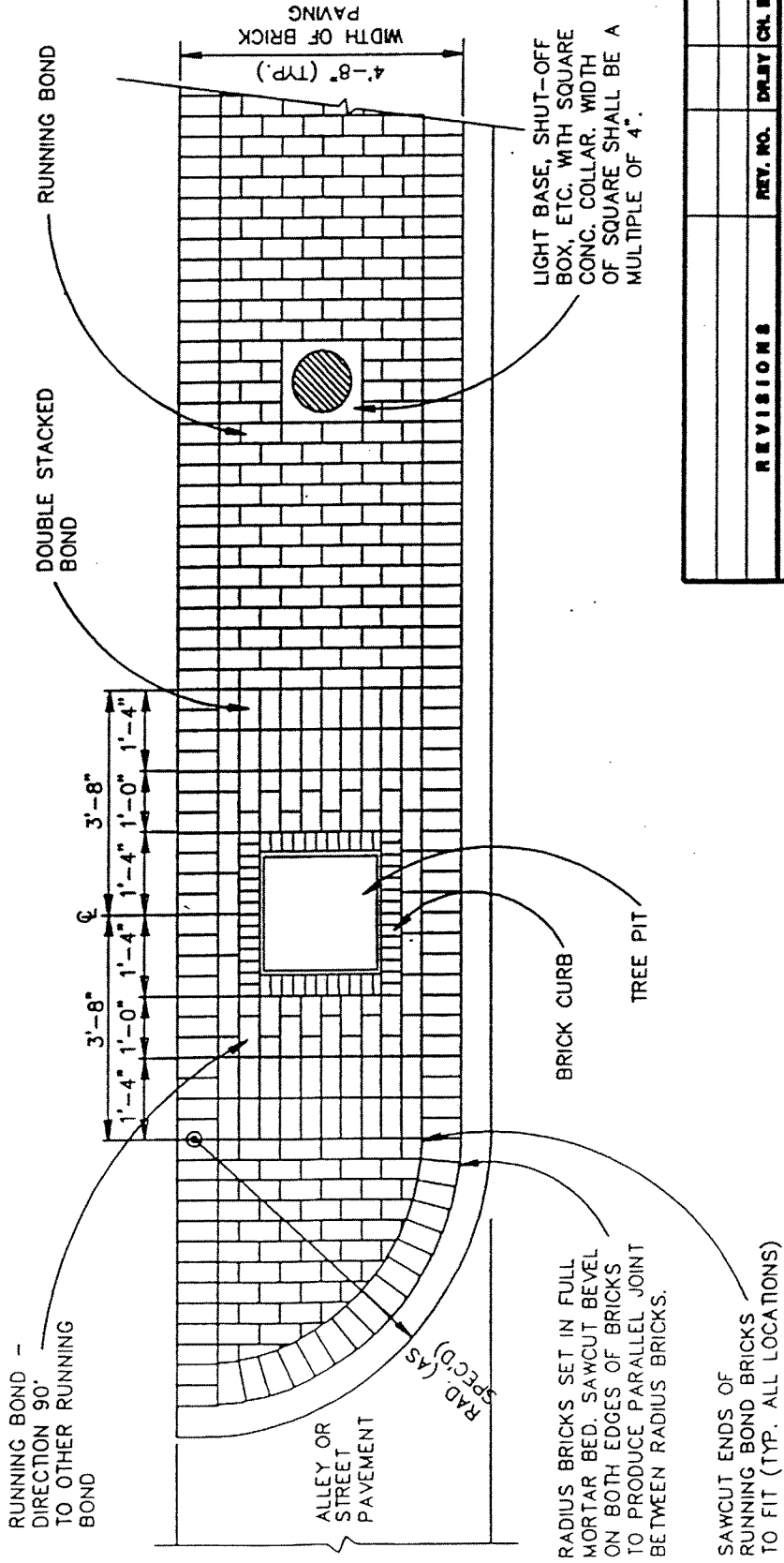

REV. NO.	DATE	CHK BY	DATE
PUBLIC SERVICES DEPARTMENT CITY OF ANN ARBOR			
DDA BRICK PAVING - PLAN			
DR. BY	NCF	CHK BY	CSS
SCALE	NONE	DATE	1-31-94
INCH 			DRAWING NO. SD-R-11
SHEET NO. <u>    </u> OF <u>    </u>			



4" TEE INTO 90° ELBOW  
UP TO PERF. END PLUG

BRICK PAVING—SET BRICK  
DIRECTLY ON STEEL PLATE

BRICK PAVING

EXPANSION JOINT

MORTAR SETTING BED  
FOR STEEL PLATE

ELECTRICAL CONDUIT  
SEE PLANS FOR SIZE

REMOVE ALL BINDINGS  
FROM TOP 1/3 OF BALL

DECORATIVE MULCH

BRICK CURB—  
1/2 BRICKS ON END

4" PERF. TUBING W/  
PROTECTIVE WRAP

1/2" STEEL PLATE

MDOT 34R  
OPEN-GRADED AGGREGATE

PLANTING MIX

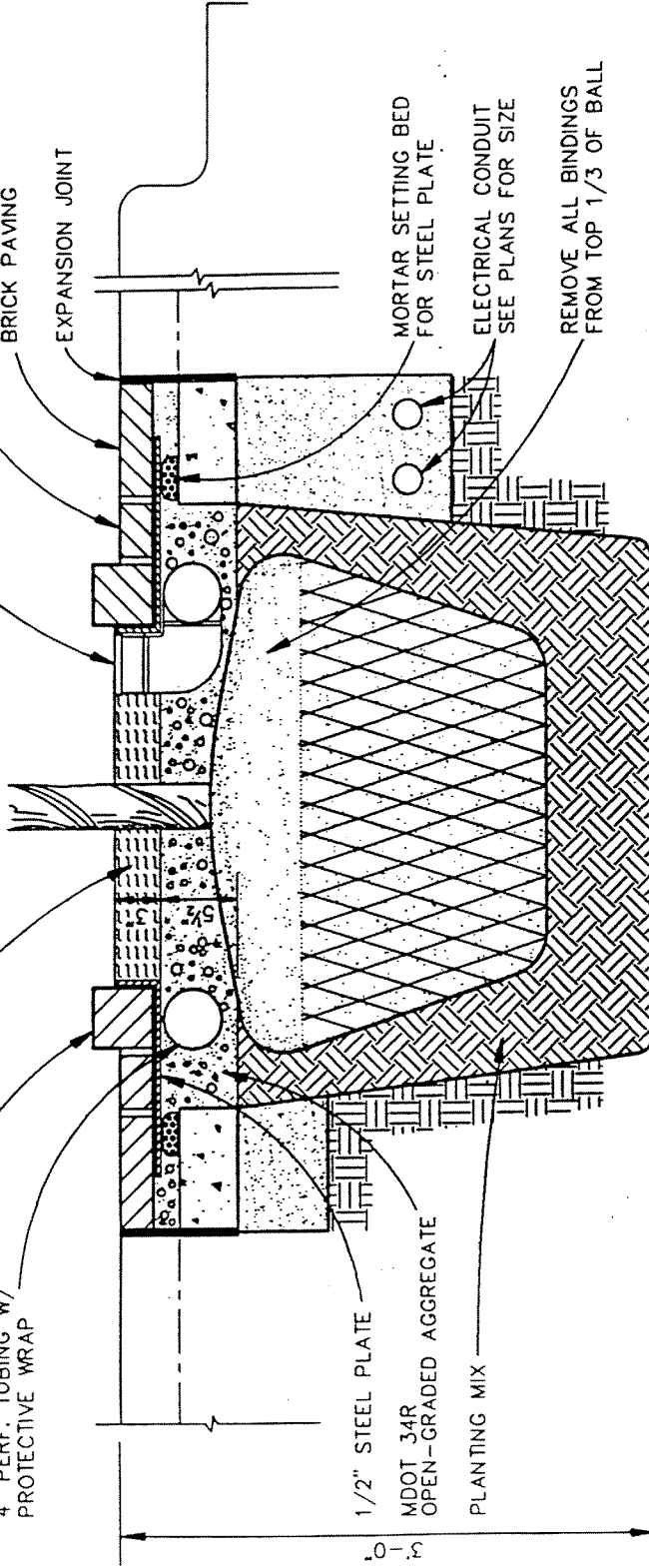

REV. NO.	DRY. NO.	CH. BY	DATE
<b>PUBLIC SERVICES DEPARTMENT</b> <b>CITY OF ANN ARBOR</b>			
DDA TREE PIT - SECTION			
DR. BY	NCF	CH. BY	CSS
SCALE	NONE	DATE	1-31-94
NCH			DRAWING NO. <b>SD-R-12</b>
SHEET NO. _____			OF _____

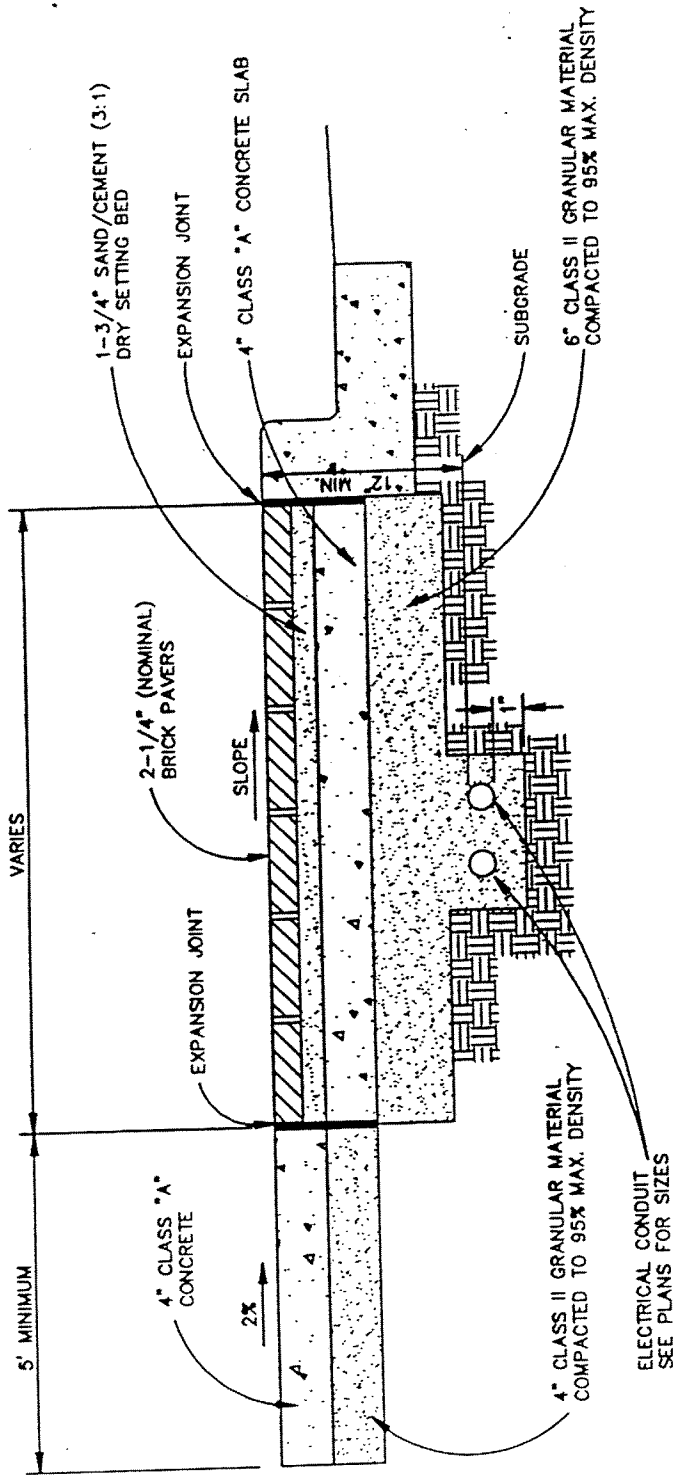

REV. NO.	REV. NO.	DATE	BY
<b>PUBLIC SERVICES DEPARTMENT</b>			
<b>CITY OF ANN ARBOR</b>			
<b>DDA BRICK PAVING SECTION</b>			
<b>DR. BY</b>	<b>NCF</b>	<b>CH. BY</b>	<b>CSS</b>
<b>SCALE</b>	<b>NONE</b>	<b>DATE</b>	<b>1-31-94</b>
<b>INCH</b>		<b>SHEET NO.</b>	<b>OF</b>

**DRAWING NO.**  
SD-R-13

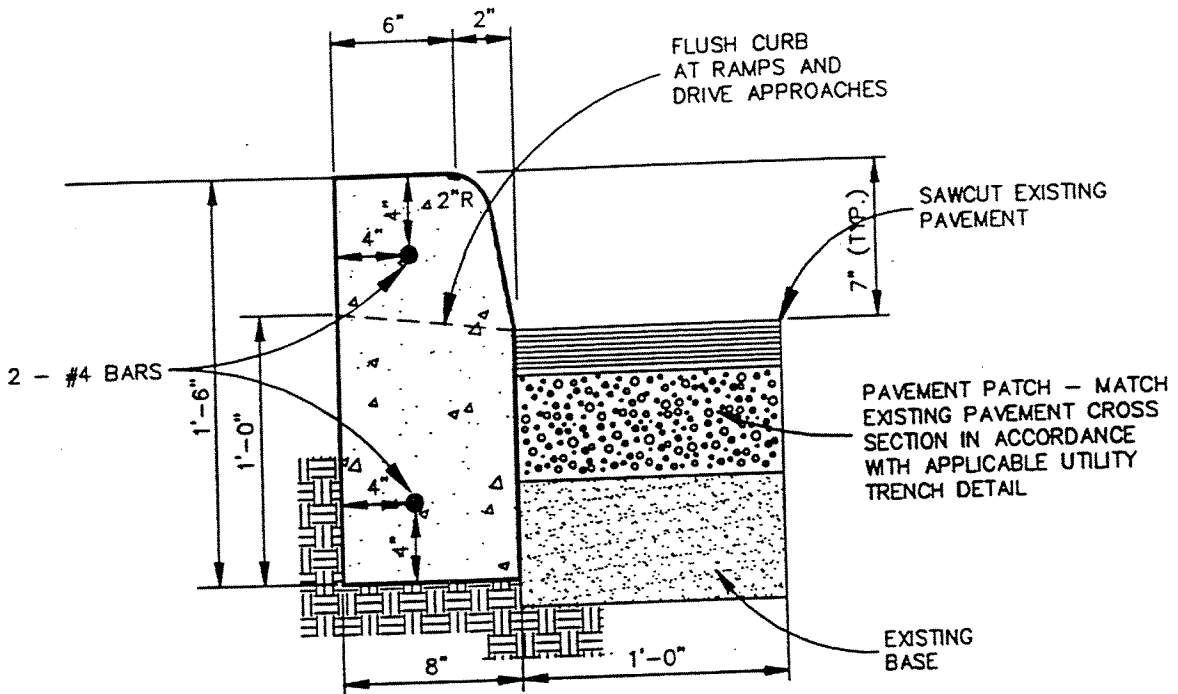

NOTE:  
 TO BE USED FOR REPLACEMENT OF  
 EXISTING SLATE OR CONCRETE CURB  
 WITH NO EXISTING GUTTER PAN

REVISIONS					REV. NO.	DR BY	CH BY	DATE
<b>PUBLIC SERVICES DEPARTMENT CITY OF ANN ARBOR</b>								
DDA CONCRETE CURB - SECTION								
DR. BY	NCF	CH. BY	CSS	DRAWING NO.				
SCALE	NONE	DATE	1-31-94	SD-R-14				
INCH				SHEET NO. _____ OF _____				

## MINIMUM SIGNING FOR WALK & DRIVE REPAIRS

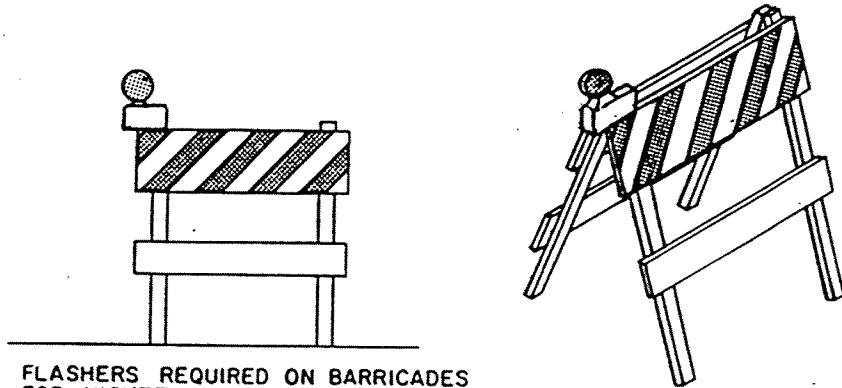

NOTE: FLASHERS REQUIRED ON BARRICADES FOR NIGHTTIME SERVICE

WIDTH OF RAIL	8" MIN. - 12" MAX.	HEIGHT	3' MIN.
LENGTH OF RAIL	2' MIN. - VAR. MAX.	TYPE OF FRAME	LIGHT "A" FRAME
WIDTH OF STRIPES	6"	FLEXIBILITY	PORTABLE

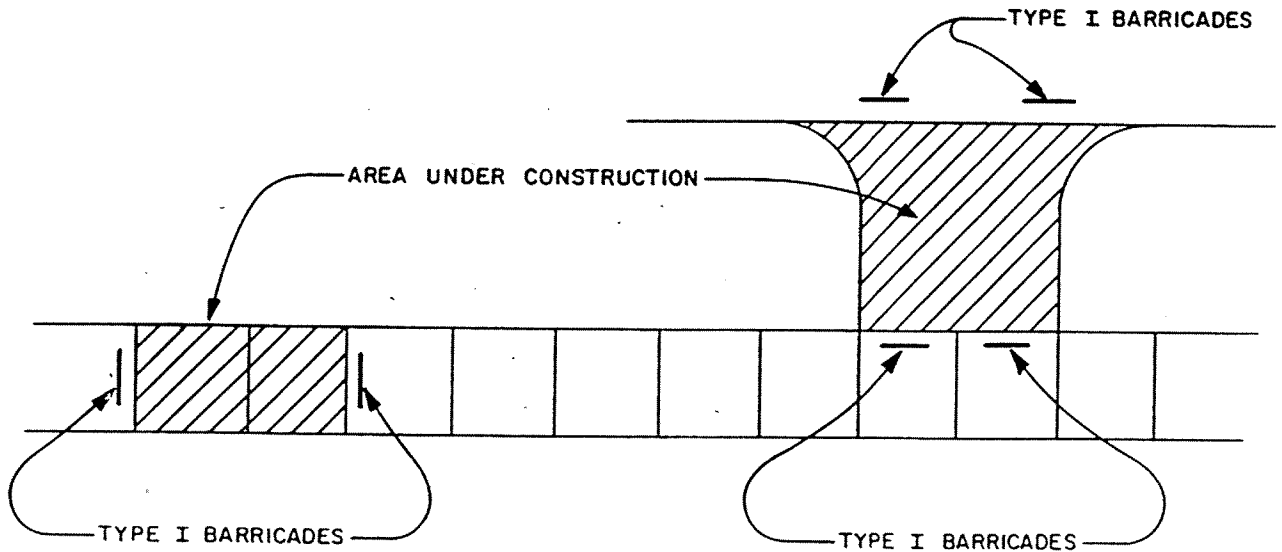

REVISIONS				
	REV. NO.	DR. BY	CH. BY	DATE
ENGINEERING DIVISION CITY OF ANN ARBOR				
TYPE I BARRICADE DETAIL				
DR. BY	D.F.	CH. BY	S.A.K.	DRAWING NO.
SCALE NONE		DATE 6-12-92		
INCH				SHEET NO. _____ OF _____

a water course or involve one acre or more of soil disturbance. For City projects which don't require this permit, written approval of the project must be obtained from the Building Department. In both cases, the applicant shall submit a completed Commercial and Industrial Grading Application to the Building Department, accompanied by two sets of plans which include the information requested in the application instructions. For further information, see Division VII, Soil Erosion and Sedimentation Control.

**Right-of-Way Permit** - This permit is obtained from the Building Department, and is required for any activity within a City right-of-way including but not limited to: utility and utility service lead construction, road construction, sidewalk and/or bikepath construction, drive approach construction, street light construction, or occupancy of the right-of-way during construction by equipment, dumpsters, scaffolding, barricading or materials. The permit applicant must have on file with the City an approved certificate of current liability insurance in an amount not less than:

\$500,000 - On account of injury to, or death of, any person in any one accident

\$ 50,000 - On account of damage to property in any one accident

The following items are to be included on the insurance certificate:

- The City must be named as an additional insured party
- The City must be listed as the certificate holder
- The cancellation clause must indicate unconditional 30 day advance notification to the City of the cancellation of, or material change in, the policy. The word "endeavor" and all language from "but failure to..." must be deleted from the standard "Acord" 25-S (7/90) insurance certificate form. (see below).

Standard Form - Not Acceptable

**CANCELLATION**

SHOULD ANY OF THE ABOVE DESCRIBED POLICIES BE CANCELLED BEFORE THE EXPIRATION DATE THEREOF, THE ISSUING COMPANY WILL ENDEAVOR TO MAIL 30 DAYS WRITTEN NOTICE TO THE CERTIFICATE HOLDER NAMED TO THE LEFT, BUT FAILURE TO MAIL SUCH NOTICE SHALL IMPOSE NO OBLIGATION OR LIABILITY OF ANY KIND UPON THE COMPANY, ITS AGENTS OR REPRESENTATIVES.

\_\_\_\_\_  
AUTHORIZED REPRESENTATIVE



- e) Prior to placement of concrete for sidewalks, curb, gutter, drive approaches and pedestrian ramps.
- f) After final adjustment of all castings, prior to placement of the wearing course of asphalt. Engineering must approve the casting adjustments and issue a Permit To Place prior to placement of the wearing course.
- g) At other times as may be necessary, including the placement of pavement markings.

The Contractor shall provide the Engineering Division a minimum of two working days notice prior to the start of construction in order to allow for the scheduling of inspection personnel. Once construction begins, it is the Contractor's responsibility to schedule further work with the Engineering Technician on a daily basis. No work shall be performed without notifying the Inspector. If work on the site ceases for more than two consecutive work days, two working days notice is required prior to restarting the work. For private development projects, if the Contractor schedules an inspection but does not arrive on the site at the scheduled time without prior notification to the Engineering Division, the Contractor will be charged a "no-show fee" for each occurrence, at the most current approved fee rate. If work is to take place on any Saturday, the Engineering Division shall be notified at least 48 hours but no more than five days in advance of the work in order to allow scheduling of inspection personnel.

The Engineering Division will also inspect the construction of all new sidewalks, bikepaths, and drive approaches within City rights-of-way or public access easements. Replacements of existing sidewalks and drive approaches which are not associated with utility service lead construction or private utility construction will also be inspected by the Engineering Division. The Engineering Division will inspect the forms and base for concrete sidewalks, bikepaths and drive approaches; and the subgrade and base for asphalt bikepaths and drive approaches. The Contractor shall provide the Engineering Division a minimum of one full working day notice prior to this inspection.

- **The Utilities Department** is to make all water main taps for testing corporations and copper water services. Service taps for copper water services will not be made in a new water main until the main has passed all required testing and has been preliminarily accepted by the Engineering Division. The Utilities Department will extend the copper water service to the curb stop location and set the curb stop and box. The location of the curb stop is to be staked by the Engineer with either straddle or double offset stakes, marked with finished grade. In addition, the adjacent property corners shall be staked.

The Utilities Department will also make connections to existing water mains for ductile iron water service leads. The Utilities Department will install the service lead up to and including the service gate valve. Inspection of the service lead from the service gate valve to the building will be performed by the Building Department.

The Utilities Department will make taps into existing City sewers for sewer service leads where a service lead has not been previously constructed. The Utilities Department will tap the existing sewer, install a saddle for the connection, and inspect the connection of the service lead to the tap. In the case of a connection to be made to an existing sewer where a tee or wye fitting is already in place with no lead stub, the Utilities Department will inspect the connection to this fitting. The location of the adjacent property corners shall be staked.

- **The Building Department** will inspect; construction of water service leads from the curb stop box or service gate valve to the building; connection of sewer service leads to existing service lead stubs; construction of sewer service leads from the point of connection to the building; and construction of all private storm sewers.

The Building Department will also inspect all grading and soil erosion controls related to any construction project on a monthly basis and in response to complaints.

- *The Transportation Division* will inspect the backfilling and restoration within City rights-of-way associated with utility service lead construction from existing utility mains, and all construction by private utility companies (Michigan Consolidated Gas, Detroit Edison, Michigan Bell, Cable TV, etc.).

The Transportation Division will also inspect all street light construction.

The Transportation Division will designate and assign all approved truck routes.

All required permits as described in Section 1D. above must be obtained for all items of work.

#### 1F. Hours of Work

Hours of work as stated in the City Code, Title IX, Chapter 119, Sec. 9:363(5) are weekdays, Monday through Saturday, between the hours of 7:00 a.m. and 8:00 p.m. At other times, work will not be permitted unless authorized by the City Administrator.

Hours of work on State trunklines are subject to the MDOT Right-of-Way Occupancy Permit for said work. Hours of work on major City roadways are subject to permit of the Public Services Director.

Contractors shall work **ONLY** when there is adequate daylight.

#### 1G. Working in the Rain

The Contractor shall not work in the rain unless authorized in writing by the Public Services Director. The Contractor shall not be compensated for unused materials or downtime caused as a result of rain. The Contractor is solely responsible for repairing all damage to the work and to the site, including road infrastructure, road subgrades, and any adjacent properties, which are caused as a result of working in the rain.

#### 1H. Work in Right-of-Way *General*

Prior to undertaking any work in a public right-of-way, the Contractor must obtain all required permits, including a Right-of-Way Permit from the Building Department, a Lane Closure Permit from the Transportation Division, and all required permits from the WCRC and MDOT as described in Section 1D. Permits, above.

It shall be the Contractor's sole responsibility to locate or have located all existing utility structures prior to commencement of construction activities. This shall be done in accordance with the State of Michigan Miss Dig Law as set forth in MCL 460.701 through MCL 460.718, Public Act 248 of 19.

#### *Street Cuts*

The Public Services Director may, if the public safety requires immediate action, grant permission to make an emergency street cut or excavation before a permit is issued.



In all cases other than sidewalk or drive approach construction the permit applicant for a street cut shall notify the City a minimum of two working days prior to the time when the work is proposed to commence so, if necessary, arrangements may be made to have an inspector present while the work is in progress. The applicant may be billed for the necessary expense of the Inspector.

Whenever a part of a block, square or section of curb, sidewalk, or driveway is broken or damaged by the person making any excavation or opening in or under any street, alley or within any public right-of-way, the entire block, square or section shall be removed to the score, groove or saw cut line and replaced or reconstructed. Where the line of cut would be less than two feet from an existing expansion or weakened plane joint, the concrete shall be removed to that joint.

At no time shall more than 200 feet of trench be opened and incompletely backfilled during working hours. The remainder of the area of trenching operation shall be available for safe vehicular and pedestrian traffic at all times. Special exceptions may be allowed by the Public Services Director. Specifications elsewhere herein may impose additional constraints on trench openings.

In no case shall any opening or trench made by a permittee be considered in the charge or care of the City, or any of its officers or employees, and no officer or employee is authorized in any way to take or assume any jurisdiction over any such opening, except in the exercise of police power, when it is necessary to protect life and property.

All openings or trenches across traffic lanes, where it becomes necessary to remove any existing surfacing or pavement, shall be provided with temporary pavement, after proper compaction of the backfill and pavement base material as specified elsewhere herein. Minimum requirements for temporary pavement shall be a bituminous patching mixture conforming to MDOT Specification Section 7.11 for mixtures, CP-3 or CP-5 as specified by the Public Services Director. Temporary pavement shall be properly maintained in a safe condition at all times by the permittee until permanent pavement is placed. Each party making street openings shall routinely check their temporary pavement. All temporary patches made between November 15 and April 15 shall be checked at least every fourteen days and repairs made as needed.

A steel plate or an approved bituminous patching mixture shall be placed on all openings within the roadway surface at the close of each working day. An exception may be granted by the Public Services Director for complete reconstruction of a street.

If the paving surfaces adjacent to the street opening may be damaged where trenches are made parallel to the street, or where a number of cross trenches are laid in close proximity to one another, or where the equipment used may cause such damage, the Public Services Director may require a negotiated contribution from the permittee for the resurfacing of such street, instead of patching, if the total area of the proposed patch (or probably damaged area) exceeds twenty-five percent of the total pavement surfacing in any block. Such negotiations shall be carried on and contributions agreed upon prior to issuance of a Right-of-Way Permit.

The work of final restoration, including both paving surface and paving base, shall be performed by the permittee in accordance with Division V, Street Construction and Repair, of these Specifications.

The final pavement surface shall be placed within fourteen days of the completion of construction within the right-of-way, as specified herein. All cuts made in the off-season (November 15th to April 15th) shall be completed before June 15 of the following construction season. Any permittee found in violation of these requirements will be denied additional permits until all openings produced by that permittee have been

properly repaired.

The permittee is responsible to correct any defect in a restored area which occurs within a period of three years from date of completion of the permanent restoration. Corrections must be completed within the time specified in the notification from the City, which shall be no longer than one work day; however, the City may correct such defect if it is determined to be a public hazard or if the permittee fails to respond in accordance with the time requirement specified herein. In either case, any expense incurred by the City in correcting such defect shall be paid by the permittee. The permittee shall receive no additional permits until such payment is received in full by the City.

In granting any permit, the Public Services Director may attach such other conditions thereto as may be reasonably necessary to prevent damage to public or private property or to prevent the operation from being conducted in a manner hazardous to life or property or in a manner likely to create a nuisance. Such conditions may include, but shall not be limited to: (1) limitations on the period of the year in which the work may be performed; (2) restrictions as to the size and type of equipment commensurate with the work to be done; (3) designation of routes upon which materials may be transported; (4) the place and manner of disposal of excavated materials; (5) requirements as to the laying of dust control materials, the cleaning of streets, the prevention of noise, and other results offensive or injurious to the neighborhood, the general public, or any portion thereof; and (6) regulations as to the use of streets in the course of the work.

Any operation in the right-of-way not covered by these Specifications, submitted with this permit, shall be done in accordance with the instructions of the Public Services Director.

## II. Traffic and Pedestrian Control and Access

The Contractor shall maintain local vehicular and pedestrian traffic and access to all properties, private drives, etc., throughout the project at all times unless otherwise noted on the Plans and arranged and approved in writing by the Public Services Director. Traffic control devices and personnel to control and direct traffic movement to residences along a road are the responsibility of the Contractor. Traffic control shall meet or exceed all MDOT minimum requirements, and be in accordance with Part VI of the Michigan Manual of Uniform Traffic Control Devices (MMUTCD), 1981 revised edition.

The Contractor shall maintain two-way traffic on major streets, access for local traffic on local streets, and keep intersections open to traffic at all times, unless specifically authorized otherwise in writing by the Public Services Director.

If it is expected that road closure will be necessary during certain construction operations, this shall be minimized as much as possible and limited to a maximum of 500 feet at any time, and a time duration of 48 hours maximum. Approval for such road closure must be obtained in writing by the Contractor from the Public Services Director prior to the closure. The Contractor shall notify each residence in writing a minimum of two days prior to such closure. A copy of this notice shall be supplied to the Public Services Director, City Solid Waste, Police and Fire Departments, Ann Arbor Transit Authority (AATA), Ann Arbor Public Schools, and U.S. Postal Service, a minimum of two working days prior to the closure. Emergency access to all residences must be maintained at all times. The Contractor shall obtain a Lane Closure Permit from the Transportation Division, a minimum of two working days in advance of any street closing or restriction of traffic.

Pedestrian traffic shall be maintained at all times. For maintaining normal pedestrian traffic while performing sidewalk and driveway repair, lighted Type II barricades shall be placed by the Contractor, as

directed by the Public Services Director. Reflective "Sidewalk Closed-Cross Here" signs shall be placed by the Contractor, as needed and as directed by the Public Services Director.

Parking violation citations issued to the Contractor, subcontractors and material suppliers, including their employees, shall be enforced under the appropriate section(s) of the City Code.

Existing City owned signs which are damaged by the Contractor during the course of construction will be repaired by the City at the Contractor's expense.

The Contractor shall temporarily cover conflicting traffic and/or parking signs only when directed by the Public Services Director. In addition, the Contractor shall submit a plan to the Public Services Department indicating the signs to be covered, for review and approval by the Public Services Director.

Where there is metered parking, the Contractor shall obtain, install and maintain at the Contractor's expense meter bags from the Transportation Division.

## 1J. Truck Routes

Truck traffic within the City must travel on designated truck routes listed below, and shown on the route map contained herein, to the point on the truck route nearest the desired destination. The shortest legal route must then be travelled between the destination and the truck route. Cut-through traffic is prohibited on any street within the City that is not designated as a truck route. The operation of trucks exceeding twenty-two feet in length or five tons gross weight (including operator and cargo) is prohibited on all non-truck routes, unless the truck is making a delivery or pick-up by means of the shortest route from, or to, a truck route.

On all truck routes, load limits shall be in accordance with the Michigan Vehicle Code, Section 257.722, except when frost limits are in effect. Frost limits may be placed on City streets during the months of February, March, and April. At these times, the load limit restrictions are reduced by 35%, excluding MDOT trunkline streets (Washtenaw Avenue, North Main Street, Huron Street, and Jackson Road between Huron Street and I-94). Frost limits shall be in effect at the time that Washtenaw County frost limits are put into effect by the Washtenaw County Weigh Master.

Requests for load limit waivers must be made in writing to the Public Services Director.

All weight restrictions shall be enforced by the City Police Department, as authorized by Chapter 126, Section 10:102 of the City Code and Section 257.726b of the Michigan Vehicle Code.

approved by the Public Services Director prior to their construction. Construction will be allowed only for that portion for which cut sheets have been approved. A minimum of one full working day is required for the review and approval of the cut sheets.

Cut sheets shall indicate an on-site benchmark elevation, invert elevations of sewers, top-of-main elevations for water main, stake elevations, cut or fill, offset distance length, all utility crossings, top-of-casting elevations for all structures (for curb inlets top-of-casting shall be at the front of the casting at the edge-of-metal), and hydrant finish grade-ring elevations.

Staking for utilities shall be every half and full station, with the exception of water main to be laid in a horizontal curve which shall be staked every 25 feet or more often if required by the Public Services Director. Every manhole, sewer tee, and water main fitting and appurtenance shall be staked and included on the cut sheet. A minimum of two offset stakes as well as a centerline stake shall be used for all manholes, fire hydrants, and gate valves. For storm sewer structures to be located in the curbline, staking shall be placed establishing the back-of-curb line for a minimum of five feet on each side of the storm sewer structure. This curb staking is in addition to, and is to be placed at the same time as, the centerline stake and two offset stakes for the structure itself.

Sanitary sewer leads are to be staked with dual offset stakes at the termination point of the lead. Sanitary leads inspected by the Engineering Division are to be included on a cut sheet.

For copper water services, the location of the curb stop box is to be staked with either straddle or double offset stakes, marked with finished grade. Ductile iron water services shall be staked as detailed above for water main, and shall be included on the cut sheet.

Staking for curb and gutter shall be every quarter station (25 feet), with horizontal and vertical curves staked every 12.5 feet. All low points, high points, PVC's, PVT's, PC's and PT's shall be staked. The maximum allowed offset will be 5 feet.

For sidewalk, bikepath and/or drive approach work, staking shall be provided by the Owner, to the satisfaction of the Public Services Director, that establishes the right-of-way line and all property corners for the limit of the work.

Construction lines and grades shall be transferred and set by the Contractor from the control lines and grades, and the Contractor shall furnish necessary instruments and competent personnel for performing such work, and shall be responsible for the accuracy of the transferred lines and grades. The Engineer and Public Services Director may check the work at intervals as they deem necessary and the Contractor shall make correction of error, if any, at the Contractor's own expense.

#### 11. Property Markers/Monuments/Benchmarks

The Contractor shall take precautions not to move or destroy any property irons, monuments, benchmarks, or stakes marking the boundaries of property along or near the work. The Contractor shall notify the Public Services Director with such promptness that all property markers, monuments, and benchmarks may be properly protected or witnessed for later replacement by the Public Services Director.

Flexible pavements are to be designed as outlined above, and shall meet the following minimum layer thickness requirements:

Total Asphalt Thickness	3 inches
Aggregate Base Course (22A dense-graded aggregate)	8 inches
Sand Subbase (Class II granular material)	6 inches (minor local, local & residential collector)
	12 inches (all others)

#### 7J. Utility Locations

1. All utility locations for residential streets shall conform to the standard locations shown on the Utility Location Plans included in Division X of these Standards.
2. Utility locations for commercial/industrial collector and arterial streets will be reviewed on an individual basis by the Public Services Director.

### 8. DRIVE APPROACHES, SIDEWALKS, AND BIKEPATHS

#### 8A. Drive Approaches

The requirements and design of drive approaches with respect to number, location, and dimensions shall be in accordance with the most current, approved version of Title IV, Chapter 47, Sections 4:17-4:20 of the City Code. A copy of these sections is included for reference in the Appendix of these Standards. However, if these Code sections are revised prior to being revised in these Standards, all requirements of the revised Code section(s) must still be met. (At the initial printing of these Standards, the current Code sections are dated 8/2/76 (4:17-4:19) and 8/8/66 (4:20)).

The angle of the drive approach to the street shall be 90 degrees.

If a median is to be used, its location with respect to the right-of-way line, and street curb must be approved by the Public Services Director.

If at any time a curb cut ceases to be functional, the curb cut shall be replaced and the approach removed by the fronting property owner.

Drive approaches shall be sloped toward the street. The minimum allowed grade shall be 3% (3/8" per foot), and the maximum allowed grade shall be 13% (1.56" per foot).

Provisions shall be made to ensure that excessive quantities of storm water drainage do not drain across the drive approach from the site into the public right-of-way. These provisions shall be subject to the approval of the Public Services Director, and may include inlet structures at the back of the public right-of-way, or grading of the private drive onto the site away from the right-of-way.

Drive approaches shall have either Type M or Type L openings, as shown in the City Standard Details, and as described below:

*Drive approaches serving up to 8 single or two-family dwelling units, sites within the DDA District, or a parking lot(s) with up to 24 parking spaces shall meet the adjacent sidewalk/bikepath grade. Thus the sidewalk/bikepath shall not be ramped down to the drive approach. Drive approaches may be either concrete or asphalt.*

Minimum requirements for concrete approaches shall be 6" thick, non-reinforced Class A concrete, on a 6" base of Class II granular material or 22A dense graded aggregate..

Minimum requirements for asphalt approaches shall be 3" of 1100 20AA asphalt placed in one lift, on a 6" base of 22A gravel.

*Private street intersections, and drive approaches outside of the DDA District which will serve a parking lot(s) with over 24 parking spaces or carry 50 or more trips during the peak hour, shall have a full curb face to the adjacent sidewalk/bikepath. The sidewalk/bikepath shall be ramped down to the drive approach with concrete ramps. Drive approaches may be either concrete or asphalt. The crosswalk across the approach shall be made either by pavement markings or scored concrete. In addition, a stop sign shall be installed at the exit of the drive, located on the property a minimum of two feet outside the right-of-way.*

Minimum requirements for concrete approaches shall be 8" thick, non-reinforced Class A concrete, on a 6" base of Class II granular material or 22A dense-graded aggregate..

Minimum requirements for asphalt approaches shall be 3" of 1100 20AA asphalt placed in one lift, on an 8" base of 22A gravel.

Drive approaches to be constructed on existing concrete streets, or on streets with mountable curb, shall be trapezoidal approaches. The opening on an existing concrete street is to be a Type L opening with the back of the curb being horizontally sawcut.

#### 8B. Sidewalks and Access Walks

Sidewalks shall be provided on both sides of all public streets. Sidewalks are to be typically located such that the outside edge is positioned six inches inside the right-of-way line. However, the sidewalk may meander within the right-of-way to protect and save trees, slopes, etc. if approved by the Public Services Director. This approval will be granted provided that any curve in the sidewalk has a minimum 15 foot radius, and that the minimum lawn extension width meets the requirements of Section 8D., Lawn Extensions.

Sidewalk ramps shall be constructed at all street intersections and shall meet the requirements of the Sidewalk Ramp detail in Division X, Standard Details of these Standards.

<u>Design Speed</u>	<u>Minimum Radius (feet) for B/P on outside of horizontal road curve (positive superelevation)</u>	<u>Minimum Radius (feet) for B/P on inside of horizontal road curve (negative superelevation)</u>
20	95	110
25	155	185
30	250	300

Concrete bikepath ramps shall be constructed at all street intersections, meeting the requirements of the Sidewalk Ramp detail in Division X, Standard Details of these Standards.

#### **8D. Lawn Extensions**

"Lawn extension" shall be defined as the area between the back of the curb on a public street and either the public sidewalk, public bikepath, or right-of-way line.

The lawn extension shall be either sodded, grass seeded or paved. Any surface treatment other than sod or grass seed must be approved by the Parks and Recreation Superintendent. Gravel, stones or other "loose" materials are not approved surface materials. Lawn extensions to be improved within the DDA District are to be in accordance with the current DDA standards.

The minimum lawn extension width shall be 3 feet. This is an absolute minimum for short sections in specified circumstances. Normal lawn extensions shall be 11 feet or greater as indicated on the Utility Location Plans in Division X, Standard Details of these Standards. A greater minimum width will be required by the Public Services Director on Arterial Streets.

The lawn extension shall be graded to drain toward the street. From the edge of the sidewalk or bikepath for a minimum of one foot, the lawn extension grade shall be 3/8" per foot (3%). The remaining lawn extension shall have a minimum grade of 3/8" per foot (3%), and a maximum grade of 4" per foot (1:3).

The use of retaining walls in the public right-of-way must be approved by the Public Services Director. Construction plans for the proposed retaining wall shall be prepared by a registered professional engineer and submitted to the Public Services Director for review and approval. The Public Services Director may require specific materials (i.e., modular precast block) for any retaining wall to be placed in the right-of-way.

DIVISION III  
MATERIALS STANDARDS

1. GENERAL

All materials shall conform to the Michigan Department of Transportation 1990 Standard Specifications for Construction, including amendments and supplements thereto, except as herein modified.

**1A. Cement and Lime**

Portland cement shall be Type I, IA, or II, conforming to MDOT Sec. 8.01.

Hydrated lime shall conform to MDOT Sec. 8.01.

**1B. Aggregates & Soil Materials**

Coarse concrete aggregates shall be 6A or 6AA limestone conforming to MDOT Sec. 8.02.

Fine concrete aggregates shall be 2NS conforming to MDOT Sec. 8.02

Dense-graded aggregates shall be MDOT Series 21, 22, or 23, as specified, conforming to MDOT Sec. 8.02, except that aggregate base courses for road construction shall be either natural aggregate or crushed limestone, and the maximum limit for loss by washing shall be 8.0%.

Dense-graded aggregate for utility bedding and backfill shall be MDOT 6A crushed limestone, conforming to MDOT Sec. 8.02.

Granular material shall be well-graded soil conforming to MDOT Sec. 8.02, Class I, II, or 2NS as specified, except that Class II shall be modified such that 100 percent passes a 2 in. square sieve and the uniformity coefficient shall be 6 or greater.

Excavated material, if used as fill material, shall consist of loam, clay, sand, gravel, or other similar material, provided all material is free of cinders, ashes, refuse, vegetable or organic matter, boulders, rocks, stones, broken concrete or other matter which, in the Engineer's judgment, is unsuitable as fill material.

Stone for riprap shall conform to the Standard Specifications for Road and Bridge Construction of MDOT. Material shall have a maximum weight per piece of 150 lbs and with not more than 5% weighing less than 3 lbs per piece. The material shall be evenly graded with 30% to 50% of material weighing not less than 75 lbs per piece.

1C. Steel Reinforcement

Reinforcing steel shall be Grade 60 conforming to MDOT Sec. 8.05.

Welded steel wire fabric shall conform to MDOT Sec. 8.05.



**1D. Structural Steel**

Structural steel shall be ASTM A 36 conforming to MDOT Sec. 8.06.  
Bolts, nuts, and washers for joining structural steel shall conform to MDOT Sec. 8.06.

**1E. Miscellaneous Metal Products**

Anchor bolts and fasteners shall conform to MDOT Sec. 8.07. Hook bolts shall conform to MDOT Sec. 8.16.

**1F. Portland Cement Concrete**

The slump for concrete to be used for curb and gutter construction shall be 0-3 inches. For flatwork (e.g., sidewalks, drive approaches) the slump shall be 2-4 inches.

Class A concrete shall consist of portland cement, coarse aggregate (6AA limestone), fine aggregate, and water, proportioned with 564 lbs. cement (6 sacks) per cubic yard to produce a minimum 28 day compressive strength of 3500 psi, conforming to MDOT Sec. 7.01, Grade 35P. When used above ground, the air content shall be 5-7%. Occasional samples falling between 4.5% and 7.5% will be permitted. The water-cement ratio, by weight, may not exceed 0.45 for air entrained concrete, or 0.50 for non-air entrained concrete.

Class A High Early Strength concrete shall be the same as Class A concrete except cement content shall be 846 lbs. (9 sacks) per cubic yard conforming to MDOT Section 7.03, Concrete Repair Mixture Type P-MS. Chloride shall be added only as directed by the City.

Class B concrete shall consist of Portland cement, coarse and fine aggregates, and water, proportioned with 517 lbs. cement (5.5 sacks) per cubic yard to produce a minimum 28 day compressive strength of 3000 psi, conforming to MDOT Sec. 7.01, Grade 30P. When used above ground, the air content shall be 5-7%. Occasional samples falling between 4.5% and 7.5% will be permitted. The water-cement ratio, by weight, may not exceed 0.45 for air entrained concrete or 0.50 for non-air entrained concrete.

Class C concrete shall consist of portland cement, coarse and fine aggregates, and water, proportioned with 470 lbs. cement (5 sacks) per cubic yard to produce a minimum 28 day compressive strength of 2500 psi. The air content shall be 5-7%. Occasional samples falling between 4.5% and 7.5% will be permitted. The water-cement ratio, by weight, may not exceed 0.45.

Class X concrete shall consist of Portland cement, coarse and fine aggregates, and water, proportioned with 282 lbs. cement (3 sacks) per cubic yard to produce a minimum 28 day compressive strength of 1000 psi.

Cement Mortar shall consist of one part Type II Portland cement, two parts fine aggregate, and sufficient water to produce a workable mix.

Cold-milling machines shall have continuously variable depth control adjustments and be capable of removing, in a single pass, bituminous material having a thickness of up to four inches. The cutting drums shall be enclosed and shall have a water sprinkling system around the reduction chamber for pollution control. Cold-milling machines shall have complete automation for slope control, when required by the Engineer.

The equipment for removing the bituminous surface shall be capable of accurately removing the bituminous surface, in one or more passes, to the grade and cross section shown on the Plans and as directed by the Public Services Director. The equipment shall also have an effective means for removing excess material from the surface and for preventing any dust resulting from the operation from escaping into the air.

## **2C. Concrete Pavement, Curb & Gutter, Sidewalk, and Drive Removal**

The limits of removal of concrete pavement, curb, gutter, sidewalk, sidewalk ramps, drive openings and drives shall be as specified on the Plans and as directed by the Public Services Director, regardless of type and thickness.

The removal of pavement, curb & gutter of any type, sidewalks, sidewalk ramps, drive openings and drives shall include saw cutting at the removal limits, as indicated on the Plans and as directed by the Engineer. All cuts shall be made at the locations specified by the Engineer, and as marked for removal. Concrete pavement to be removed as a result of utility construction shall be removed to the nearest joint so as to provide for a replacement of not less than one foot wider and longer than the utility trench on each side. If the concrete pavement has a bituminous overlay, the removal limits shall be as required in Section 2A, Bituminous Pavement Cutting and Removal.

Reinforcement bars shall be left protruding at least two feet from the face of the cut and shall be bent out of the way in a manner which allows for their being properly spliced to new reinforcement. If the reinforcement bars are cut, the new reinforcement is to be doweled into the remaining concrete and secured by means of an anchor manufactured specifically for that purpose and approved by the Public Services Director.

Curb and gutter, sidewalk, sidewalk ramps, drive openings and drives shall be replaced within two working days of their removal. Areas which have been excavated and are not yet up to finish grade shall be adequately protected with lighted barricades or fencing at all times.

Removed materials not incorporated into the work shall become the property of the Contractor and shall be properly and immediately disposed of off-site by the Contractor at the Contractor's expense. Removed materials may not be stockpiled overnight on or adjacent to the site.

The removal of subbase or subgrade, not authorized by the Public Services Director, shall be replaced and compacted by the Contractor at the Contractor's expense, with materials specified by the Public Services Director.

## **2D. Subbase and Base Removal and Replacement**

All contaminated subbase and/or base material beneath areas of bituminous or concrete pavement, shall be removed for the full depth of the contamination at the direction of the Public Services Director.

the requirements of Division VIII, Soil Erosion and Sedimentation Control at all times.

#### 4. CONCRETE CURB & GUTTER, SIDEWALK, AND DRIVE CONSTRUCTION

##### 4A. Concrete Curb & Gutter

Concrete curb and gutter shall be constructed as shown on the Plans and Details.

Concrete mixtures and curing compound shall meet the requirements of Division III, Materials, of these Specifications.

All curb and gutter is to be constructed prior to placement of street pavement, unless integral with a concrete pavement. A minimum seven-day cure of the concrete curb and gutter shall be required before paving of adjacent bituminous pavement.

Prior to placing any concrete, the road base shall be completed within the limits of the work area. The road base shall be trimmed to final elevation before placing the curb and gutter. The curb and gutter shall not be placed on a pedestal or mound.

The road base and adjacent concrete shall be wet down prior to placement of concrete to prevent water loss through the road base, and to form a better bond between old and new concrete. If a construction joint is required, the existing concrete surface is to be cleaned with compressed air to expose the aggregate in the concrete.

The concrete curb and gutter shall be finished in a neat and workmanlike manner, with a light broom finish. The top-of-curb or edge-of-metal shall not vary by more than 3/16-inch in 10 feet when checked with a 10-foot straight edge. The balance of the exposed surfaces shall not vary more than 3/8 inch from the alignment and typical cross section. Variation from these requirements will be grounds for rejection and replacement of the curb and gutter. Water shall not be added to the concrete surface ("blessing" the concrete) to aid in finishing.

Three-quarter inch expansion joints shall be placed at all street returns, in line with all expansion joints in an abutting pavement, each side of all driveways (at radius points) and elsewhere at 300 foot maximum intervals.

Expansion joint filler shall extend to the full depth of the joint. After installation, the top shall not be above the concrete nor be more than 1/2 inch below it. No reinforcing steel shall extend through the expansion joint.

Control joints shall be placed to divide the structure into uniform sections, normally ten feet in length, with a minimum length of eight feet, and shall be placed opposite all control joints in an abutting concrete base course.

Control joints shall be formed by narrow divider plates, one-eighth of an inch thick, which shall extend three inches into the exposed surfaces of the curb or curb and gutter. Plates shall be notched, if necessary, to permit the steel reinforcement to be continuous through the joint.

After finishing operations have been completed, and immediately after the free water has left the surface, the surfaces shall be completely coated and sealed with a uniform layer of white membrane curing compound. This curing compound shall meet the requirements of Division III Materials of these Standards and shall be applied in accordance with the MDOT Specifications, Section 4.50.16.

The Contractor shall backfill behind the curb with approved excavated material or Class II granular material, compacted to 90% of the maximum unit weight as determined by the AASHTO T-180 method; and, restore all disturbed areas to better than or equal to their existing condition in accordance with Division VIII, Landscaping and Restoration of these Standards, within two working days, from the date of concrete placement. This includes the restoration of lawns and lawn extensions.

Any curb and gutter which is marked by graffiti, cracks other than at joints, or otherwise damaged before it has been accepted by the Public Services Director shall be replaced by the Contractor at the Contractor's expense.

#### 4B. Concrete Sidewalk

Concrete sidewalk shall be constructed as shown on the Plans and Details.

Concrete mixtures and curing compounds shall meet the requirements of Division III, Materials, of these Specifications.

The base material and adjacent concrete shall be wet down prior to placement of concrete to prevent water loss through the base, and to form a better bond between old and new concrete. If a construction joint is required, the existing concrete surface is to be cleaned with compressed air to expose the aggregate in the concrete.

The concrete sidewalk shall be finished in a neat and workmanlike manner, with a light, broom finish.

Water shall not be added to the concrete surface ("blessing" the concrete) to aid in finishing.

Control joints shall be placed at 5 foot intervals and may be tooled or sawed. The method of forming joints and spacing shall be approved by the Public Services Director prior to construction.

Three-quarter inch thick expansion joints shall be placed through concrete sidewalk in line with all expansion joints in the abutting curb, gutter, or combination curb and gutter. Transverse expansion joints shall be placed through the sidewalks at all property lines.

One-half inch thick expansion joints shall be placed between the sidewalk and back of abutting curb or gutter, at the juncture of two sidewalks, at the juncture of a sidewalk and a drive approach, and between the sidewalk and buildings or other rigid structures.

After finishing operations have been completed and immediately after the free water has left the surface, the surfaces shall be completely coated and sealed with a uniform layer of white membrane curing compound. This curing compound shall meet the requirements of Division III, Materials of these Standards and shall be applied in accordance with MDOT Specifications Section 4.50.16.

The Contractor shall restore all disturbed areas to better than or equal to their existing condition in accordance with Division VIII, Landscaping and Restoration of these Standards, within two working

days, from the date of concrete placement. This includes the restoration of lawns and lawn extensions which are to be restored.

Any sidewalk which is marked by graffiti, cracks other than at joints, or otherwise damaged before it has been accepted by the Public Services Director shall be replaced by the Contractor at the Contractor's expense.

#### 4C. Concrete Drive

Concrete drives shall be constructed as shown on the Plans and Details.

Concrete mixtures and curing compounds shall meet the requirements of Division III, Materials, of these Specifications.

The base material and adjacent concrete shall be wet down prior to placement of concrete to prevent water loss through the base, and to form a better bond between old and new concrete. If a construction joint is required, the existing concrete surface is to be cleaned with compressed air to expose the aggregate in the concrete.

The concrete drives shall be finished in a neat and workmanlike manner, with a light, broom finish.

Control and expansion joints shall be located as called for on the Details. The method of forming plane of weakness and contraction joints shall be approved by the Public Services Director prior to construction.

After finishing operations have been completed and immediately after the free water has left the surface, the surfaces shall be completely coated and sealed with a uniform layer of white membrane curing compound. This curing compound shall meet the requirements of Division III, Materials of these Standards and shall be applied in accordance with MDOT Specifications Section 4.50.16.

The Contractor shall restore all disturbed areas to better than or equal to their existing condition in accordance with Division VIII, Landscaping and Restoration of these Standards, within two working days, from the date of concrete placement. This includes the restoration of lawns and lawn extensions which are to be restored.

Any drive which is marked by graffiti, cracks other than at joints, or otherwise damaged before it has set shall be rejected and shall be replaced.

### 5. BITUMINOUS PAVEMENT CONSTRUCTION

#### 5A. Cleaning

Before placing the bond coat, the existing pavement surface including joints, cracks and edges shall be thoroughly cleaned to a minimum depth of one inch with compressed air, vac-all type equipment, or other approved mechanical or hand methods, to remove all dirt, debris, and all foreign material.

Immediately prior to placing the bond coat, the entire surface shall be cleaned with vac-all or similar equipment(s) approved by the Public Services Director. The equipment shall have an effective means for preventing any dust resulting from the operation from escaping into the air.

\* MAXIMUM LANDING SLOPE IN ANY DIRECTION IS 2.0%. MINIMUM LANDING DIMENSIONS 5' x 5'.

\*\* MAXIMUM CROSS SLOPE ON RAMP IS THE SAME AS THAT FOR SIDEWALK (2.0%). RUNNING SLOPE 5% - 7% (8.3% MAXIMUM) SEE NOTES.

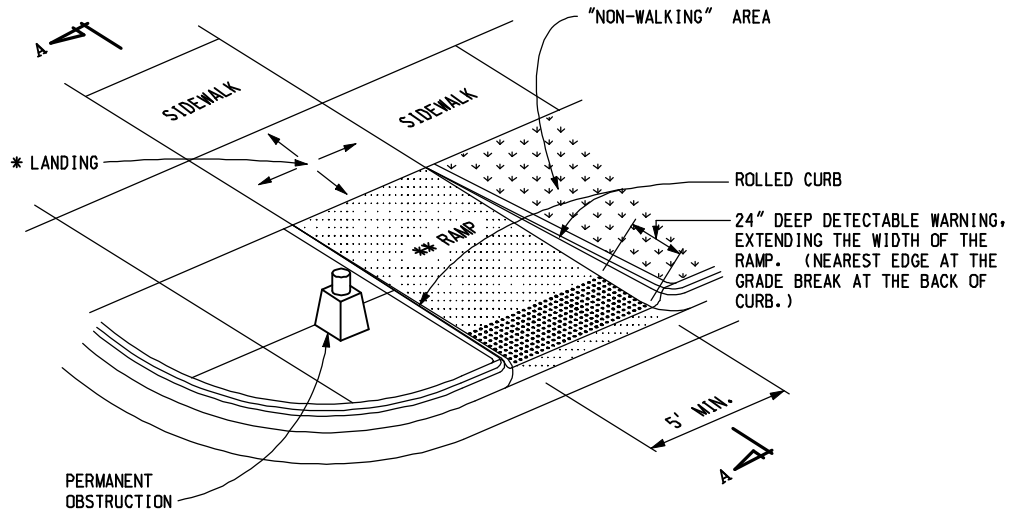

**SIDEWALK RAMP TYPE R**  
(ROLLED SIDES)

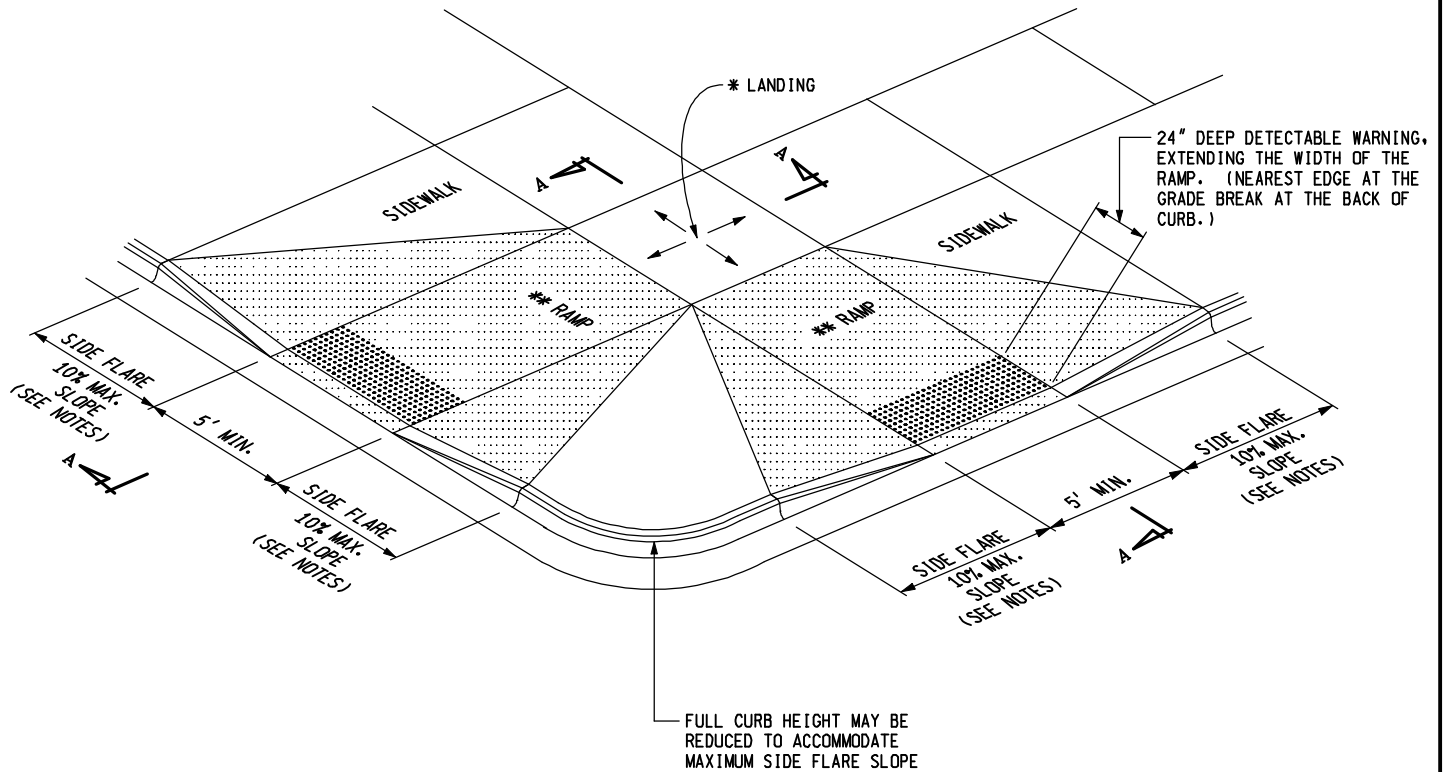

**SIDEWALK RAMP TYPE F**  
(FLARED SIDES, TWO RAMPS SHOWN)



PREPARED BY  
DESIGN DIVISION

DRAWN BY: B.L.T.

CHECKED BY: W.K.P.

DEPARTMENT DIRECTOR  
Kirk T. Stuedle

APPROVED BY: \_\_\_\_\_  
ENGINEER OF DELIVERY

APPROVED BY: \_\_\_\_\_  
ENGINEER OF DEVELOPMENT

MICHIGAN DEPARTMENT OF TRANSPORTATION  
BUREAU OF HIGHWAY DEVELOPMENT STANDARD PLAN FOR

**SIDEWALK RAMP AND  
DETECTABLE WARNING DETAILS**

F.H.W.A. APPROVAL

6-20-2008  
PLAN DATE

**R-28-F**

SHEET  
1 OF 7

\* MAXIMUM LANDING SLOPE IN ANY DIRECTION IS 2.0%. MINIMUM LANDING DIMENSIONS 5' x 5'.

\*\* MAXIMUM CROSS SLOPE ON RAMP IS THE SAME AS THAT FOR SIDEWALK (2.0%). RUNNING SLOPE 5% - 7% (8.3% MAXIMUM) SEE NOTES.

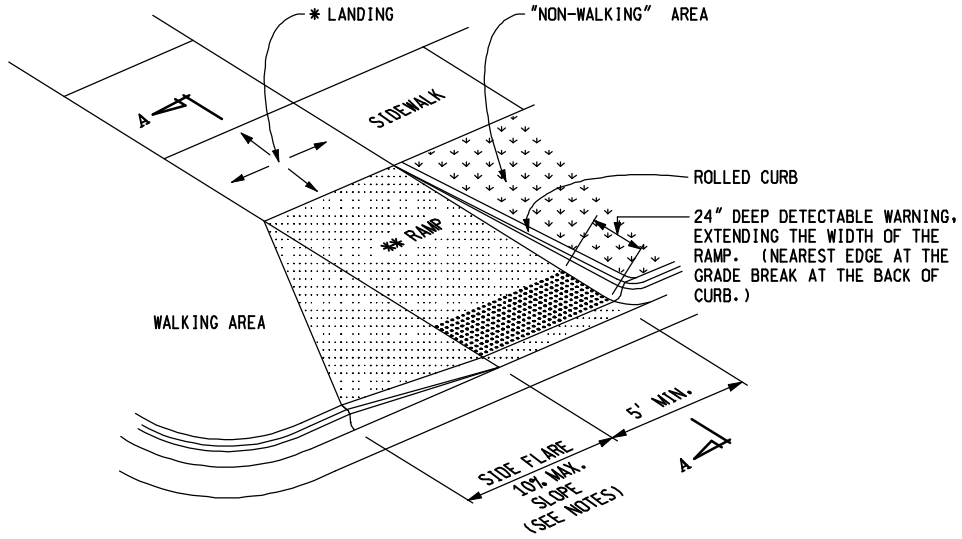

**SIDEWALK RAMP TYPE RF**  
(ROLLED / FLARED SIDES)

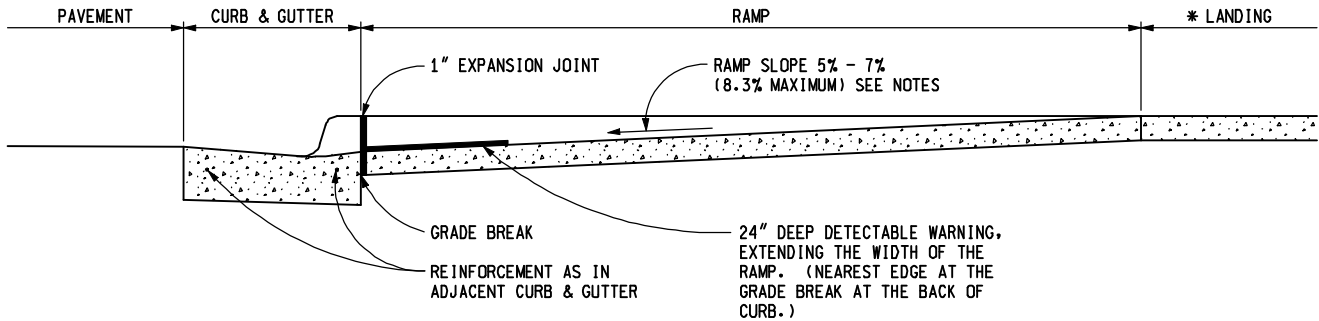

**SECTION A-A**

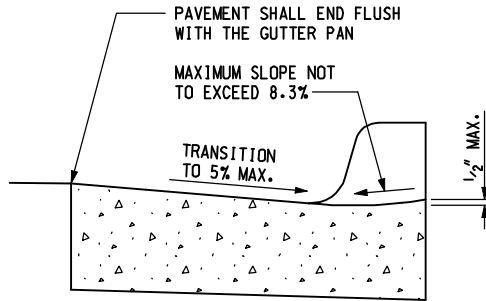

**SECTION THROUGH CURB CUT**  
(TYPICAL ALL RAMP TYPES)

MICHIGAN DEPARTMENT OF TRANSPORTATION BUREAU OF HIGHWAY DEVELOPMENT STANDARD PLAN FOR <b>SIDEWALK RAMP AND          DETECTABLE WARNING DETAILS</b>			
F.H.W.A. APPROVAL	6-20-2008 PLAN DATE	<b>R-28-F</b>	SHEET 2 OF 7
CONTROL SECTION	JOB NO.	SHEET NO.	

\* MAXIMUM LANDING SLOPE IN ANY DIRECTION IS 2.0%. MINIMUM LANDING DIMENSIONS 5' x 5'.

\*\* MAXIMUM CROSS SLOPE ON RAMP IS THE SAME AS THAT FOR SIDEWALK (2.0%). RUNNING SLOPE 5% - 7% (8.3% MAXIMUM) SEE NOTES.

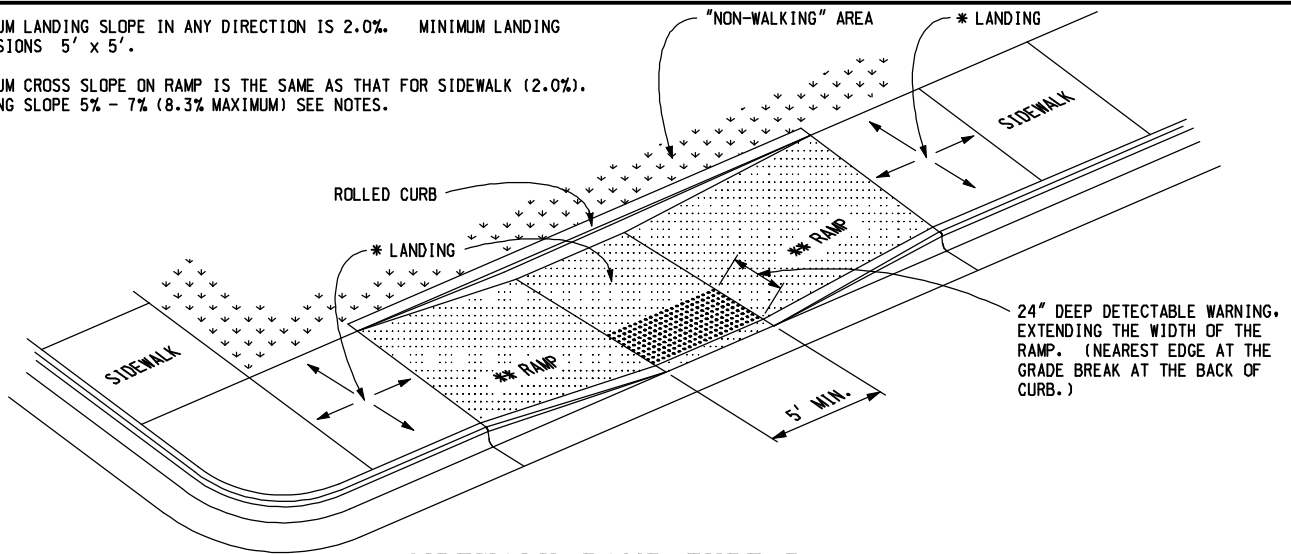

**SIDEWALK RAMP TYPE P**

(PARALLEL RAMP)

DO NOT USE IN AREAS WHERE PONDING MAY OCCUR

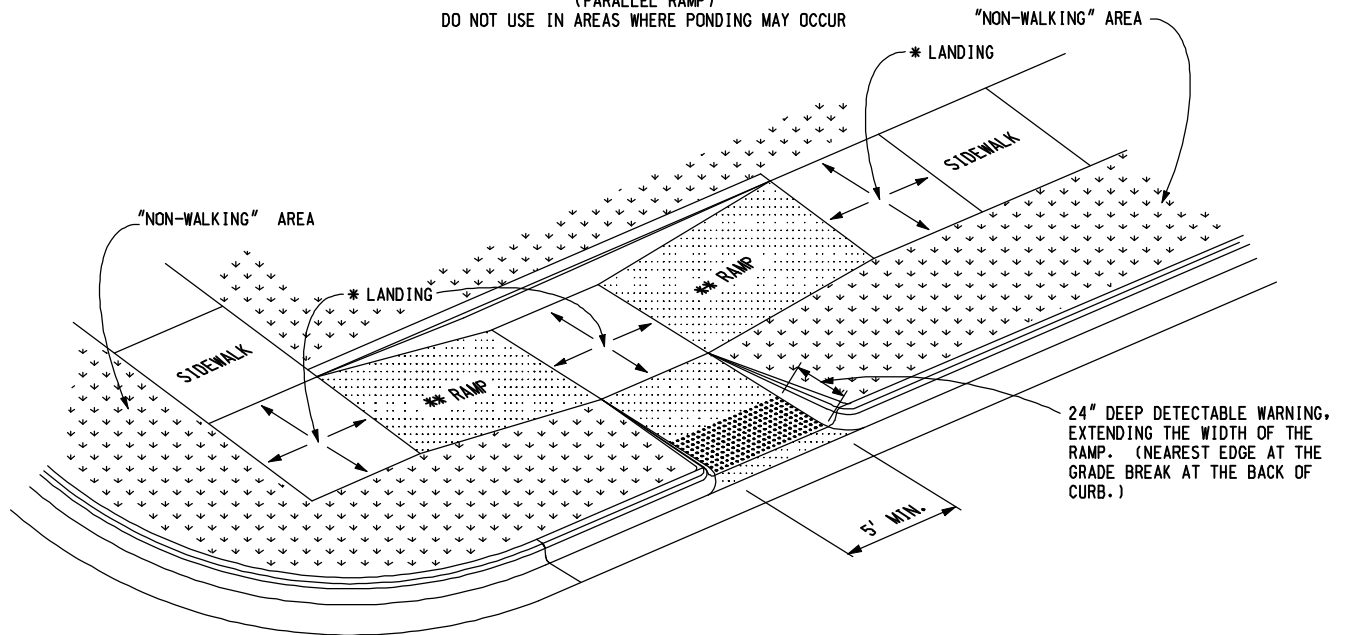

**SIDEWALK RAMP TYPE C**

(COMBINATION RAMP)

USE 24" DEEP DETECTABLE WARNINGS IF MEDIAN WIDTH IS AT LEAST 6'-0". OTHERWISE NO DETECTABLE WARNING IS REQUIRED.

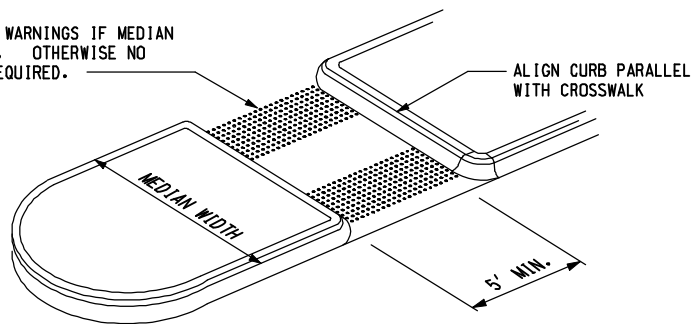

**SIDEWALK RAMP TYPE M**

(MEDIAN ISLAND)

MICHIGAN DEPARTMENT OF TRANSPORTATION  
BUREAU OF HIGHWAY DEVELOPMENT STANDARD PLAN FOR

**SIDEWALK RAMP AND  
DETECTABLE WARNING DETAILS**

F.H.W.A. APPROVAL	6-20-2008 PLAN DATE	R-28-F	SHEET 3 OF 7
-------------------	------------------------	--------	-----------------



\* MAXIMUM LANDING SLOPE IN ANY DIRECTION IS 2.0%. MINIMUM LANDING DIMENSIONS 5' x 5'.

\*\* MAXIMUM CROSS SLOPE ON RAMP IS THE SAME AS THAT FOR SIDEWALK (2.0%). RUNNING SLOPE 5% - 7% (8.3% MAXIMUM) SEE NOTES.

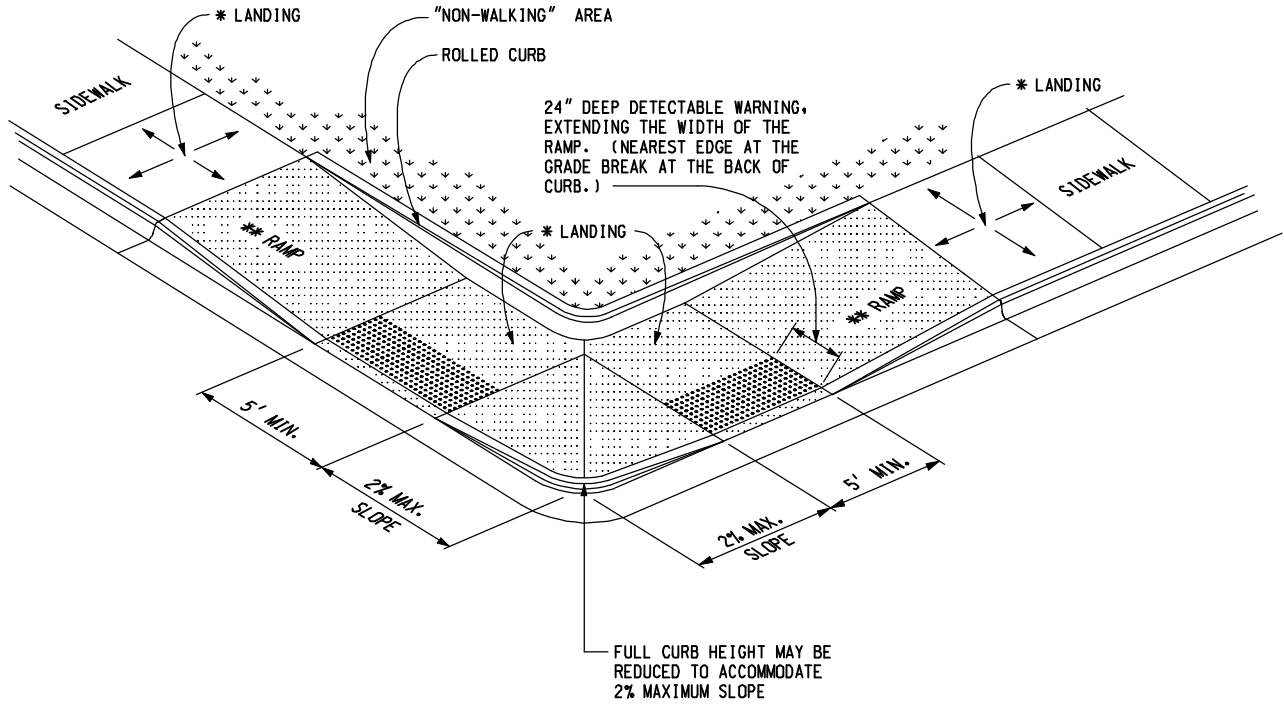

**SIDEWALK RAMP TYPE PF**  
(PARALLEL WITH FLARE)

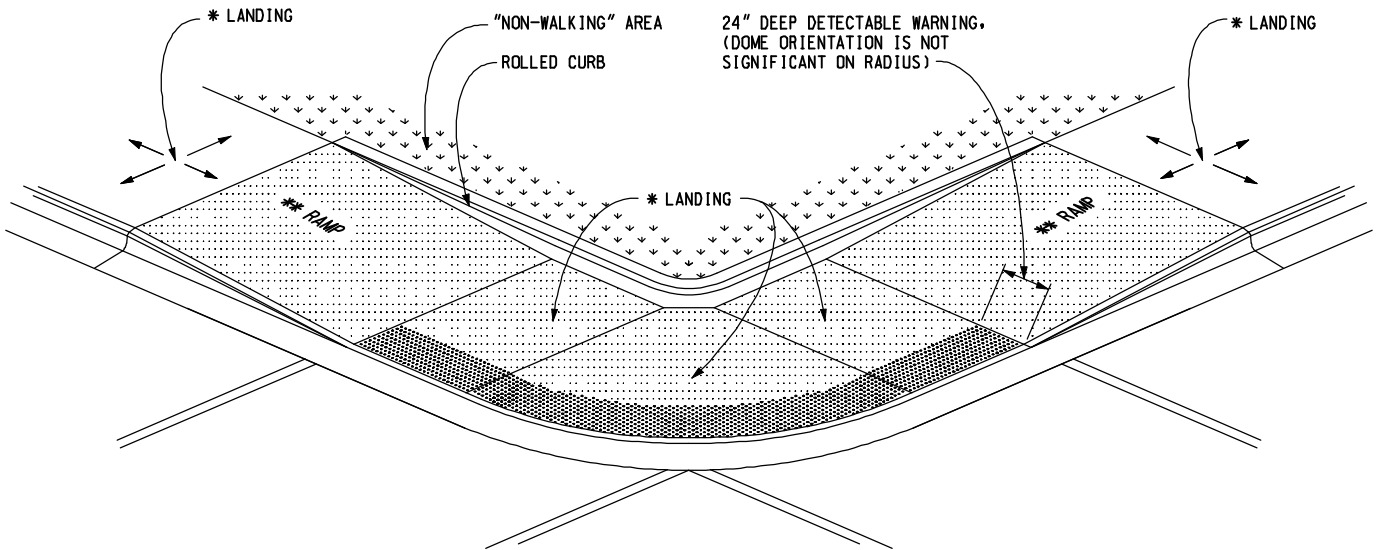

**SIDEWALK RAMP TYPE D**  
(DEPRESSED CORNER)

MICHIGAN DEPARTMENT OF TRANSPORTATION  
BUREAU OF HIGHWAY DEVELOPMENT STANDARD PLAN FOR

**SIDEWALK RAMP AND  
DETECTABLE WARNING DETAILS**

F.H.W.A. APPROVAL	6-20-2008 PLAN DATE	R-28-F	SHEET 4 OF 7
CONTROL SECTION	JOB NO.	SHEET NO.	

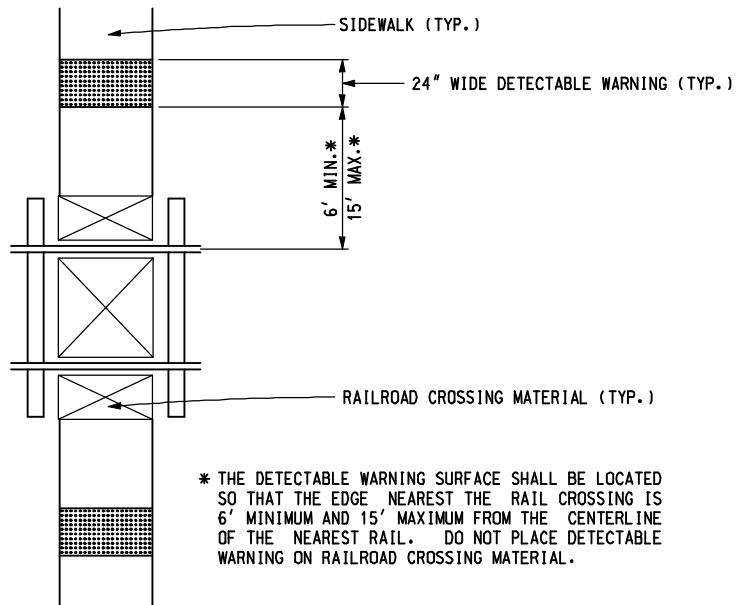



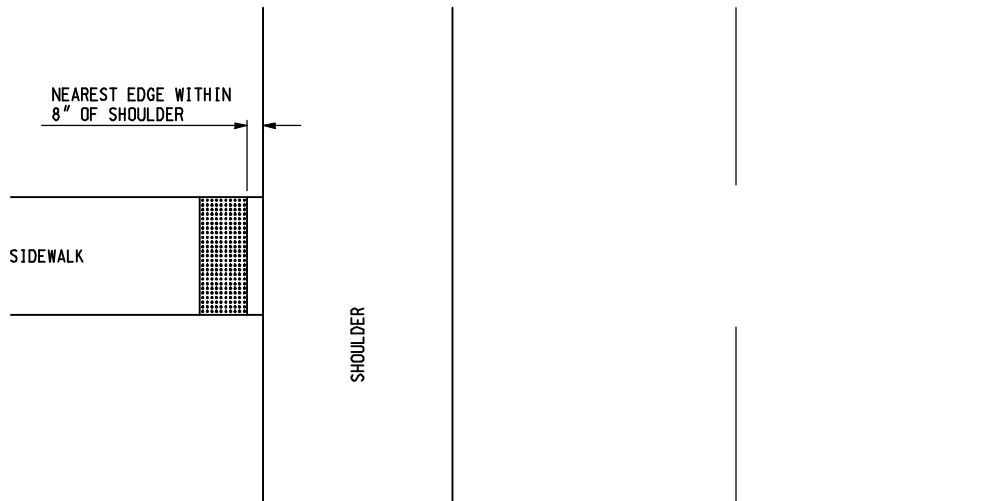



**SIDEWALK RAMP TYPE RR**  
(DETECTABLE WARNING AT RAILROAD CROSSING)



**SIDEWALK RAMP TYPE FS**  
(DETECTABLE WARNING AT FLUSH SHOULDER)

MICHIGAN DEPARTMENT OF TRANSPORTATION BUREAU OF HIGHWAY DEVELOPMENT STANDARD PLAN FOR			
<b>SIDEWALK RAMP AND          DETECTABLE WARNING DETAILS</b>			
_____ F.H.W.A. APPROVAL	6-20-2008 PLAN DATE	<b>R-28-F</b>	SHEET 5 OF 7

**LEGEND**

	SIDEWALK RAMP
	"NON-WALKING" AREA
	CROSSWALK MARKING
	CROSSWALK MARKING
	PREFERRED LOCATION OF DRAINAGE INLET (TYP.)
	ALTERNATE LOCATION OF DRAINAGE INLET (TYP.)

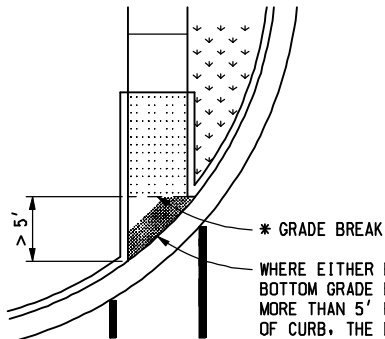

\* GRADE BREAK  
 WHERE EITHER END OF THE BOTTOM GRADE BREAK IS MORE THAN 5' FROM THE BACK OF CURB, THE DETECTABLE WARNING SHALL BE LOCATED ON THE LOWER LANDING. (DOME ORIENTATION IS NOT SIGNIFICANT ON RADIUS)

SIDEWALK RAMP LOCATED IN RADIUS (TYPE R SHOWN)  
 (GRADE BREAK GREATER THAN 5')

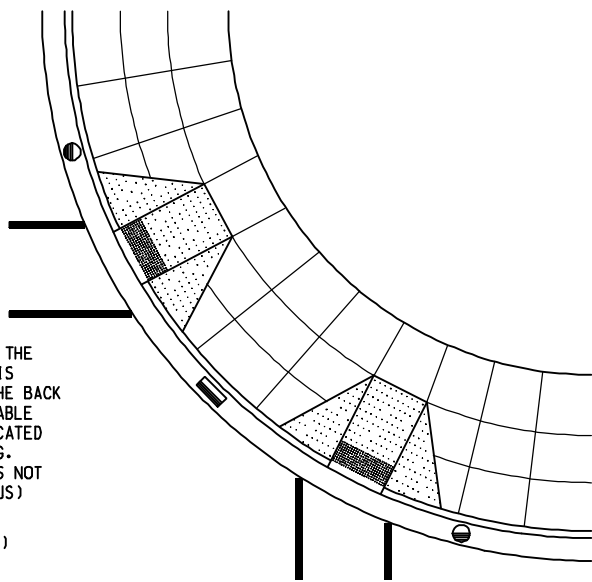

SIDEWALK RAMP PERPENDICULAR TO RADIAL CURB (TYPE F SHOWN)  
 (USE WITH RADIAL CURB WHEN THE CROSSWALK AND SIDEWALK RAMP ARE NOT ALIGNED)

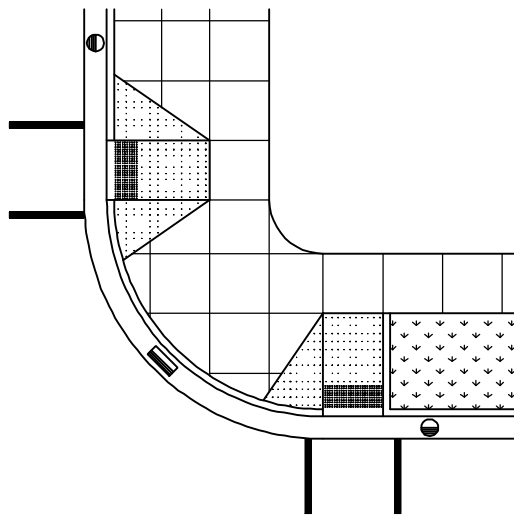

SIDEWALK RAMP PERPENDICULAR TO TANGENT CURB  
 (TYPE F AND TYPE RF SHOWN)

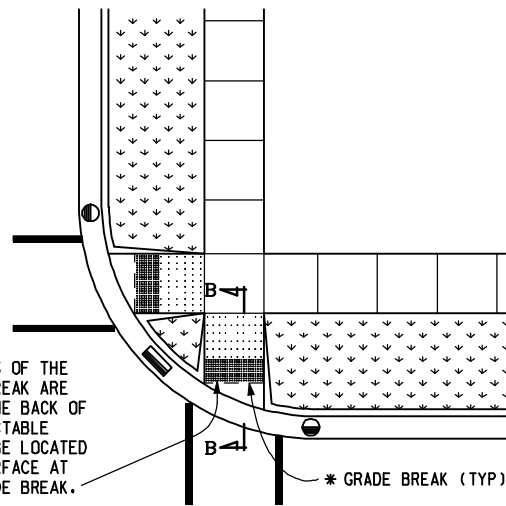

WHERE BOTH ENDS OF THE BOTTOM GRADE BREAK ARE WITHIN 5' OF THE BACK OF CURB, THE DETECTABLE WARNING SHALL BE LOCATED ON THE RAMP SURFACE AT THE BOTTOM GRADE BREAK.

SIDEWALK RAMP LOCATED IN RADIUS (TYPE R SHOWN)  
 (GRADE BREAK LESS THAN 5')

\* GRADE BREAKS AT THE TOP AND BOTTOM OF PERPENDICULAR CURB RAMPS SHALL BE PERPENDICULAR TO THE DIRECTION OF RAMP RUN. AT LEAST ONE END OF THE BOTTOM GRADE BREAK SHALL BE AT THE BACK OF CURB.

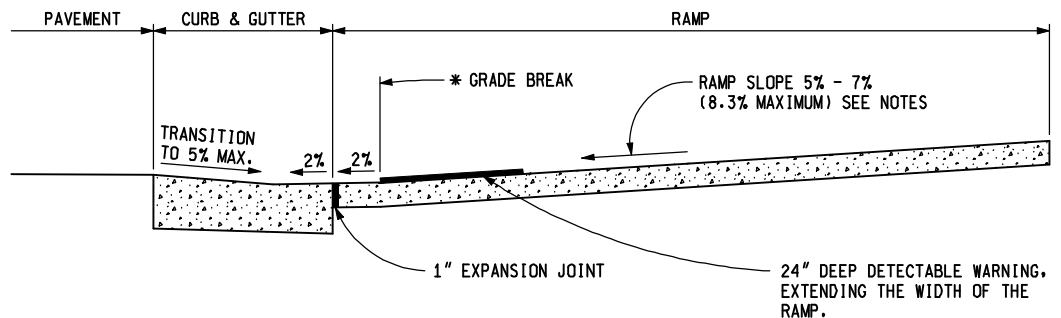

**SECTION B-B  
 SIDEWALK RAMP ORIENTATION**

MICHIGAN DEPARTMENT OF TRANSPORTATION  
 BUREAU OF HIGHWAY DEVELOPMENT STANDARD PLAN FOR

**SIDEWALK RAMP AND  
 DETECTABLE WARNING DETAILS**

F.H.W.A. APPROVAL	6-20-2008	R-28-F	SHEET
	PLAN DATE		6 OF 7
CONTROL SECTION	JOB NO.	SHEET NO.	

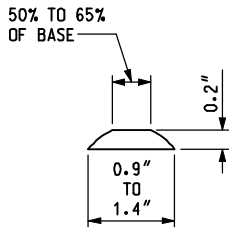

**DOME SECTION**

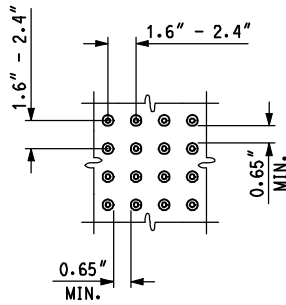

**DOME SPACING**

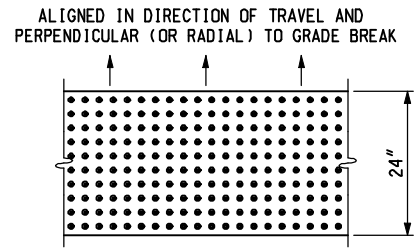

**DOME ALIGNMENT**

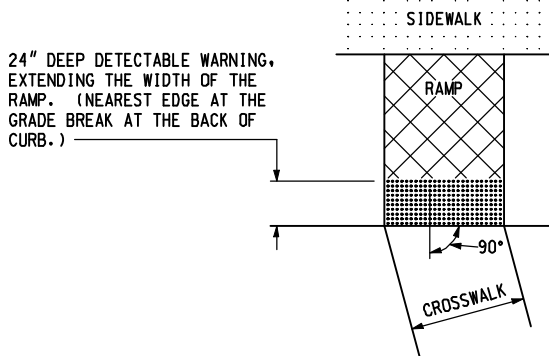

**DETECTABLE WARNING DETAILS**

**NOTES:**

DETAILS SPECIFIED ON THIS PLAN APPLY TO ALL CONSTRUCTION, RECONSTRUCTION, OR ALTERATION OF STREETS, CURBS, OR SIDEWALKS BY ALL PUBLIC AGENCIES AND BY ALL PRIVATE ORGANIZATIONS CONSTRUCTING FACILITIES FOR PUBLIC USE.

SIDEWALK RAMPS ARE TO BE LOCATED AS SPECIFIED ON THE PLANS OR AS DIRECTED BY THE ENGINEER.

RAMPS SHALL BE PROVIDED AT ALL CORNERS OF AN INTERSECTION WHERE THERE IS EXISTING OR PROPOSED SIDEWALK AND CURB. RAMPS SHALL ALSO BE PROVIDED AT WALK LOCATIONS IN MID-BLOCK IN THE VICINITIES OF HOSPITALS, MEDICAL CENTERS, AND LARGE ATHLETIC FACILITIES.

SURFACE TEXTURE OF THE RAMP SHALL BE THAT OBTAINED BY A COARSE BROOMING, TRANSVERSE TO THE SLOPE OF RAMP.

SIDEWALK SHALL BE RAMPED WHERE THE DRIVEWAY CURB IS EXTENDED ACROSS THE WALK.

CARE SHALL BE TAKEN TO ASSURE A UNIFORM GRADE ON THE RAMP, FREE OF SAGS AND SHORT GRADE CHANGES. WHERE CONDITIONS PERMIT, IT IS DESIRABLE THAT THE SLOPE OF THE RAMP BE IN ONLY ONE DIRECTION, PARALLEL TO THE DIRECTION OF TRAVEL.

RAMP WIDTH SHALL BE INCREASED, IF NECESSARY, TO ACCOMMODATE SIDEWALK SNOW REMOVAL EQUIPMENT NORMALLY USED BY THE MUNICIPALITY.

THE MAXIMUM RUNNING SLOPE OF 8.3% IS RELATIVE TO A FLAT (0%) REFERENCE. HOWEVER, IT SHALL NOT REQUIRE ANY RAMP OR SINGLE RAMP WITHIN A COMBINATION OF RAMPS TO EXCEED 15 FEET IN LENGTH.

IF POSSIBLE, DRAINAGE STRUCTURES SHOULD NOT BE PLACED IN LINE WITH RAMPS. EXCEPT WHERE EXISTING DRAINAGE STRUCTURES ARE BEING UTILIZED IN THE NEW CONSTRUCTION, LOCATION OF THE RAMP SHOULD TAKE PRECEDENCE OVER LOCATION OF DRAINAGE STRUCTURE.

THE SLOPE OF THE GUTTER PAN SHALL BE TRANSITIONED TO A MAXIMUM OF 5% IN THE AREA OF THE CURB CUT OF THE SIDEWALK RAMP. MAINTAIN THE NORMAL GUTTER PAN SLOPE ACROSS THE DRAINAGE STRUCTURE INLETS.

THE TOP OF THE JOINT FILLER FOR ALL RAMP TYPES SHALL BE FLUSH WITH THE ADJACENT CONCRETE.

CROSSWALK AND STOP LINE MARKINGS, IF USED, SHALL BE SO LOCATED AS TO STOP TRAFFIC SHORT OF RAMP CROSSINGS. SPECIFIC DETAILS FOR MARKING APPLICATIONS ARE GIVEN IN THE "MICHIGAN MANUAL OF UNIFORM TRAFFIC CONTROL DEVICES".

FLARED SIDES WITH A SLOPE OF 10% MAXIMUM, MEASURED ALONG THE CURB LINE, SHALL BE PROVIDED WHERE A CIRCULATION PATH CROSSES THE SIDEWALK RAMP. FLARED SIDES ARE NOT REQUIRED WHERE THE EDGES OF A SIDEWALK RAMP ARE PROTECTED BY LANDSCAPING OR OTHER BARRIERS TO TRAVEL BY WHEELCHAIR USERS OR PEDESTRIANS ACROSS THE EDGE OF THE SIDEWALK RAMP.

MICHIGAN DEPARTMENT OF TRANSPORTATION  
BUREAU OF HIGHWAY DEVELOPMENT STANDARD PLAN FOR

**SIDEWALK RAMP AND  
DETECTABLE WARNING DETAILS**

F.H.W.A. APPROVAL	6-20-2008 PLAN DATE	R-28-F	SHEET 7 OF 7
CONTROL SECTION	JOB NO.	SHEET NO.	