

### ORIGINAL ASSESSOR'S PLAT NO. 46

PART OF THE W 1/2 OF SECTION 20, T2S, R6E, CITY OF ANN ARBOR,  
WASHTENAW COUNTY, MICHIGAN, A REPLAT OF LOTS 9 THRU 15 &  
PART OF LOTS 2 THRU 8 OF HISCOCK'S IMPROVED PLAT

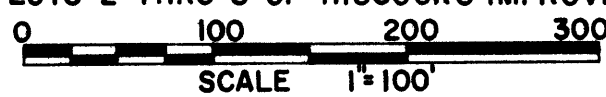

ALL DIMENSIONS IN FEET AND DECIMALS THEREOF  
ALL DIMENSIONS ON CURVES ARE ARC LENGTHS  
SURVEY BY ATWELL-HICKS, INC.

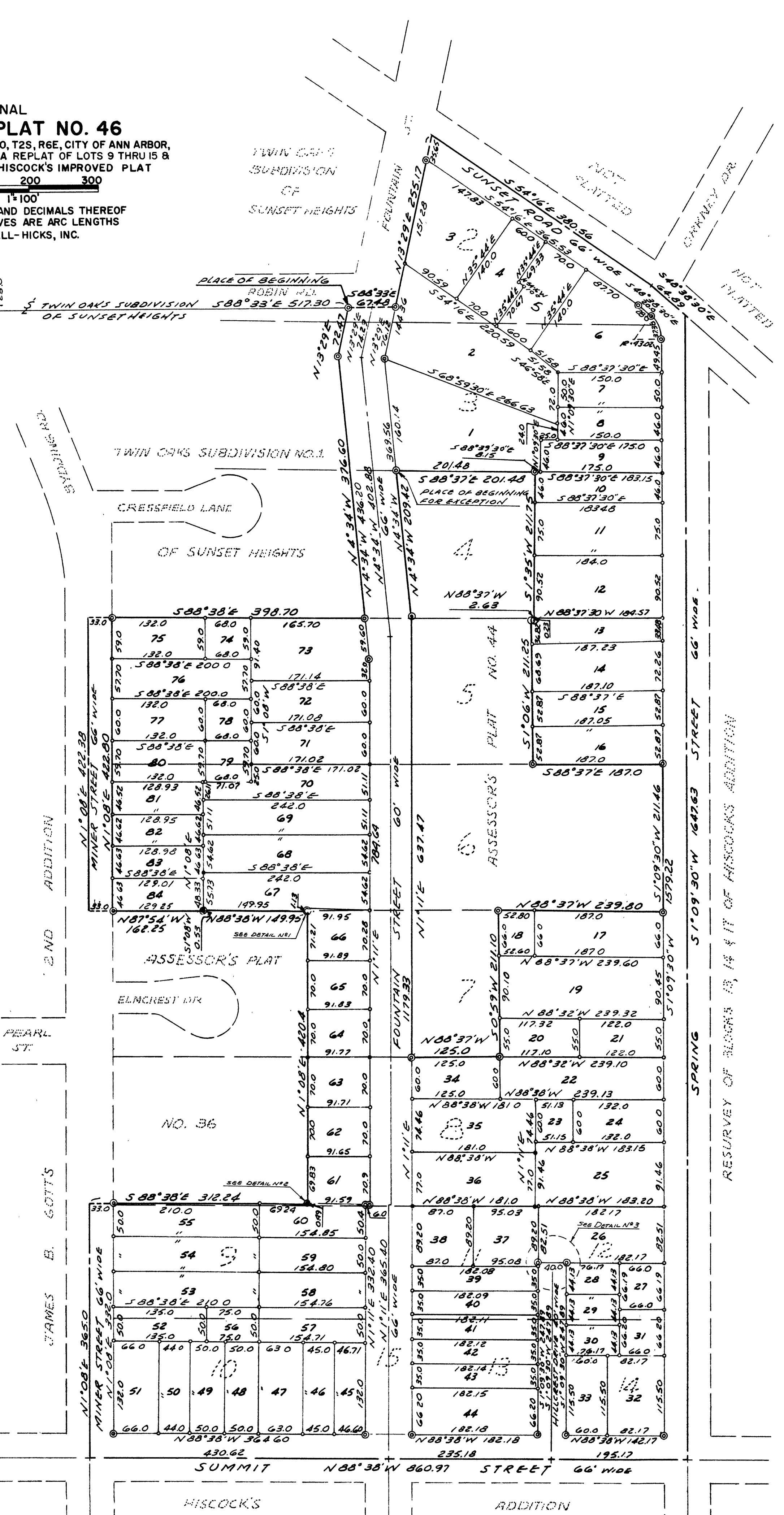
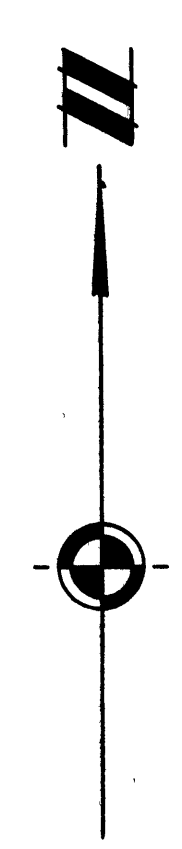
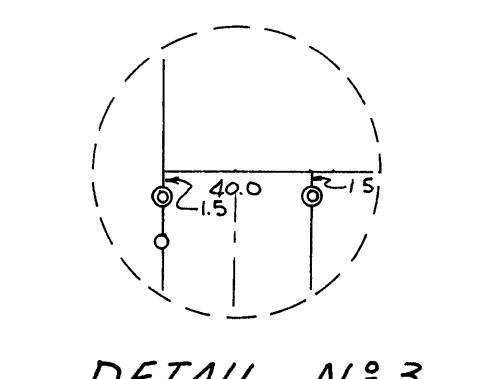
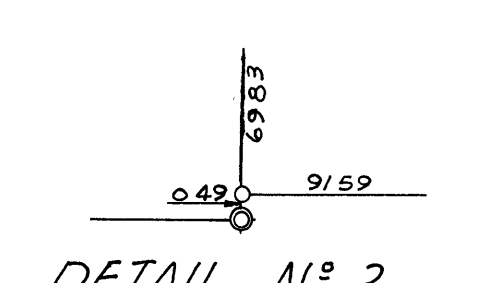
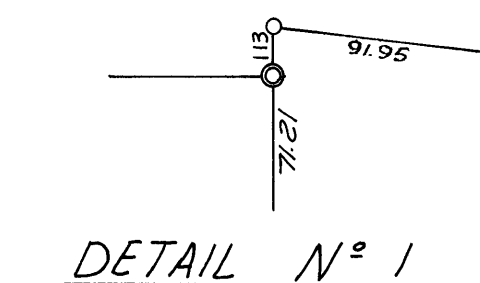
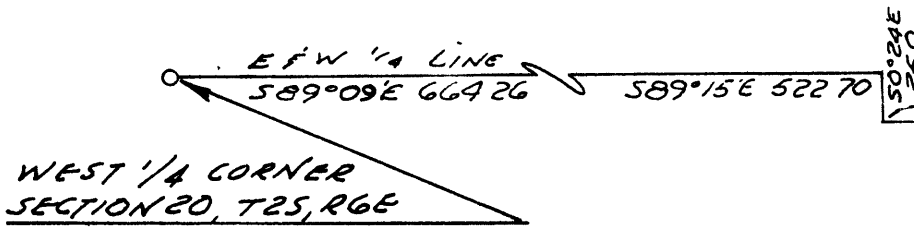

MINER STREET 66' WIDE  
FOUNTAIN STREET 60' WIDE  
SUMMIT STREET 66' WIDE  
SPRING STREET 66' WIDE  
CANNON DR

TWIN OAKS SUBDIVISION NO. 1  
CRESSFIELD LAND OF SUNSET HEIGHTS  
HISCOCK'S ADDITION

RESURVEY OF BLOCKS 13, 14 & 15 OF HISCOCK'S ADDITION

NOT PLATTED

