

**ADDENDUM NO. 3
TO
BID DOCUMENTS FOR
STREET RESURFACING - 2016
FOR THE
CITY OF ANN ARBOR, MICHIGAN**

The following changes, additions, and/or deletions shall be made to the Bid Documents for Street Resurfacing - 2016, for the City of Ann Arbor, Michigan, ITB No. 4422.

The information contained herein shall take precedence over the original documents and all previous addenda, and is appended thereto. **This Addendum includes 201 page(s).**

The Contractor is to acknowledge receipt of this Addendum No. 3 on page ITB-1 of the Bid Documents prior to submitting its Proposal.

The following forms provided within this ITB Document must be included in submitted bids.

- **City of Ann Arbor Prevailing Wage Declaration of Compliance**
- **City of Ann Arbor Living Wage Ordinance Declaration of Compliance**
- **Vendor Conflict of Interest Disclosure Form**
- **City of Ann Arbor Non-Discrimination Ordinance Declaration of Compliance**

Bids that fail to provide these completed forms listed above upon bid opening will be rejected as non-responsive and will not be considered for award.

I. CORRECTIONS/ADDITIONS/DELETIONS

Changes in the Bid Documents outlined below are referenced to a page or drawing in which they appear conspicuously. The Bidder is to take note in its review of the documents and include these changes as they affect work or details in other areas not specifically referenced here.

Item #1: Pre-Bid Conference Summary and Sign-In Sheet pages ADD-3-5 thru ADD-3-7

Item #2: Bid Forms, pages BF-1 thru BF-7; replace these pages with attached pages ADD-3-8 thru ADD-3-14. An electronic file (Microsoft Excel format), *ITB 4422 E-Bid Form_Addendum 3.xlsx*, is available on the MITN website for use in completing the bid.

Item #3: Notice to Bidders pages DS-1 and DS-2; replace with attached pages ADD-3-15 and ADD-3-16.

- Item #4: Detailed Specification for General Conditions pages DS-3 and DS-4; replace with attached pages ADD-3-17 and ADD-3-18.
- Item #5: Detailed Specification for Project Schedule pages DS-11 and DS-12; replace with attached pages ADD-3-19 and ADD-3-20.
- Item #6: Insert Schedule of Streets pages ADD-3-21 thru ADD-3-22
- Item #7: Detailed Specification for Machine Grading pages DS-15 thru DS-21; replace with attached pages ADD-3-23 thru ADD-3-28.
- Item #8: Insert Detailed Specification for Drainage and Utility Structures page ADD-3-29.
- Item #9: Detailed Specification for Structure Covers pages DS-25 and DS-26; replace with attached pages ADD-3-30 and ADD-3-31.
- Item #10: Remove Detailed Specification for Drainage Structures pages DS-29 thru DS-31.
- Item #11: Insert Detailed Specification for Drainage Structure, Double Inlet page ADD-3-32.
- Item #12: Remove Detailed Specification for Remove HMA Pavement Around Casting page DS-34.
- Item #13: Detailed Specification for HMA Paving pages DS-36 thru DS-38; replace with attached pages ADD-3-33 thru ADD-3-35.
- Item #14: Remove Detailed Specification for Acceptance of HMA Mixtures pages DS-39 thru DS-42.
- Item #15: Insert Detailed Specification for HMA Traffic Calming Measures page ADD-3-36.
- Item #16: Detailed Specification for HMA Wedging pages DS-43 and DS-44; replace with attached page ADD-3-37.
- Item #17 Remove Detailed Specification for Speed Hump (Standard)/Raised Intersection page DS-45.
- Item #18: Insert Detailed Specification for Removing Hot Mix Asphalt Around Structure Covers page ADD-3-38.

- Item #19: Detailed Specification for Flowable Fill page DS-46; replace with attached pages ADD-3-39 and ADD-3-40.
- Item #20: Remove Detailed Specification for Integral Sidewalk Retaining Wall (6" or less)/Integral Sidewalk Retaining Wall (6"-18") page DS-53 and DS-54
- Item #21: Insert Detailed Specification for Sidewalk Retaining Walls pages ADD-3-41 and ADD-3-42.
- Item #22: Remove Detailed Specification for Remove and Replace Brick Pavers, Any Type page DS-55 and DS-56
- Item #23: Insert Detailed Specification for Removal and Reinstallation of Concrete or Clay Brick Pavers pages ADD-3-43 and ADD-3-44.
- Item #24 Detailed Specification for Pavement Markings pages DS-61 and DS-62; replace with attached page ADD-3-45.
- Item #25 Detailed Specification for Maintaining Traffic pages DS-63 thru DS-66; replace with attached pages ADD-3-46 thru ADD-3-50.
- Item #26: Insert MDOT Maintaining Traffic Typical M0240a pages ADD-3-51 and ADD-3-52.
- Item #27: Detailed Specification for Minor Traffic Control pages DS-86 and DS-89; replace with attached pages ADD-3-53 and ADD-3-56.
- Item #28: Detailed Specification for Protecting and Preserving Irrigation Systems page DS-91; replace with attached page ADD-3-57.
- Item #29 Detailed Specification for Electrical and Communication Handholes pages DS-94 and DS-95; replace with attached pages ADD-3-58 and ADD-3-59.
- Item #30: Remove Detailed Specification for Sanitary Sewer pages DS-96 thru DS-117.
- Item #31: Appendices Cover Page page APDX-1; replace this page with the attached page ADD-3-60.
- Item #32: Insert Soil Boring Logs pages ADD-3-61 thru ADD-3-93.
- Item #33 Remove City of Ann Arbor Standard Details for Sewer Connection (SD-S-6) and Sanitary Sewer Connection with Riser (SD-S-7).

Item #34: Insert City of Ann Arbor Standard Detail for Double Inlet Structure (SD-S-11) page ADD-3-94.

Item #35: Insert MDOT Special Provision for Acceptance of Hot Mix Asphalt Mixture on Local Agency Projects pages ADD-3-95 thru ADD-3-101.

Item #36: Insert MDOT Standard Plan for Concrete Curb and Concrete Curb & Gutter pages ADD-3-102 and ADD-3-103.

Item #37: Contract Plan Set; replace Addendum 1 issued plan set (sheets 1 thru 97) with that issued for this Addendum 3 (sheets 1 thru 98).

Changes include the following:

Plan Sheet 1 of 98 (Cover Sheet) – Revised SHEET INDEX TABLE.

Plan Sheets 67 thru 71 of 98 – Removed work proposed at the Hill Street location (plan sheets 67-70) and replaced it with work on Maiden Lane.

Plan Sheets 2, 6, 14, 25, 33, 44, 55, 72, 84, 87, 90, 92, 94, and 96 of 98 (Location Cover Sheets) – Revised QUANTITY TABLE and QUANTITY TABLE for Sign, Type B, Temp, Prismatic to reflect correct pay items and quantities respective to each location, revised CONSTRUCTION METHOD AND SEQUENCING notes to reflect work required at each respective location.

Bidders are responsible for any conclusions that they may draw from the information contained in the Addendum.

Street Resurfacing – 2016 (ITB No. 4422)
Pre-Bid Conference Summary
March 7, 2016

1:30 p.m., 1st Floor South Conference Room, City Hall

I. Introductions

II. General

a. Project Overview

Proposed work was described as a program similar in size and scope to the 2015 program, and it will again be utilizing County Millage funds approved for this fiscal year together with other funding sources.

Bid Opening – It was noted the project bids are due on Tuesday, March 15, 2016, by 10:00 a.m., and that the responsible low bidder and all subcontractors assigned to the Bid must be MDOT Prequalified in order to receive award of the Contract. It was also noted that the City was considering only requiring this prequalification of the paving contractor/subcontractor and this change, if determined acceptable, would be issued in a future addendum.

b. Standard Specifications and Detailed Specifications

i. New Construction Specifications (MDOT 2012 Standard Specifications for Construction)

It was noted that this year's program is unique to the City of Ann Arbor in that construction is to be completed in accordance with Michigan Department of Transportation (MDOT) 2012 Standard Specifications for Construction and not the City's Standard Specifications, which are dated and in the process of being rewritten. Requirements for unique work are identified in the Detailed Specifications and Special Provisions contained in the Bid documents.

ii. Project Schedule & Payment

The project schedule was discussed as outlined in the Detailed Specification for Project Schedule. It was noted that a recommendation to approve the award of the construction contract for this project is planned to be brought before City Council at its April 18, 2016, regularly scheduled meeting.

- Starting Date – May 9, 2016
- Completion Date – October 15, 2015
- Project Phasing

It was also noted that there is no particular phasing required of the project, and that a detailed "Schedule of Streets" showing the proposed work locations and scheduling requirements/restrictions for each is forthcoming and will be issued in a future addendum.

- Hours of Work: 7:00 am – 8:00 pm Monday thru Saturday (Sundays w/approval)

iii. General Conditions

Attention was given to this Detailed Specification, and those in attendance work were advised to review its requirements.

iv. Project Supervision

Attention was given to this Detailed Specification, and those in attendance work were advised to review its requirements.

III. Construction

a. Construction Methods and Sequencing

It was noted that all work on Major Streets as part this year's project will require phased part width construction with exception to Huron River Drive, which will be closed to traffic. The requirements for the construction methods and sequencing related to all locations are noted on the plans, and are in the process of being updated for release in a future addendum. These revisions will address the type of HMA mixes to be used at each location together with other items of work.

b. Maintenance of Traffic (M.O.T.)

It was noted that with exception to the Depot Street and Huron River Drive locations all work on Major Streets as part this year's project will require maintenance of traffic in one direction only with traffic in the opposite direction operating on posted detours. M.O.T. on Depot Street requires that traffic operate in both directions, while Huron River Drive will be closed with traffic detoured in both directions. It was also noted that more detailed M.O.T. plans are included in this year's project, and this should be an improvement over past years.

c. Special Concerns (local traffic access, pedestrians access, tree protection...)

IV. Addendum Items

No addenda have been issued to date for this project; however, Addendum 1 is expected to be released later today (Monday, March 7, 2016) or early tomorrow (Tuesday, March 8, 2016). This addendum will address changes to the plans regarding incorrect quantity tables, construction keys, and construction method and sequencing notes. A second addendum is expected to be issued later this week to address the other items identified below and as a result of this meeting or questions submitted by interested bidders. It was noted that all questions related to the bid are due by 12:00 p.m. tomorrow (Tuesday, March 8, 2016).

V. Other Items

It was noted that the Hill Street location shown on the plans will be removed from the project, and an alternate location (Maiden Lane between Island Drive and Maiden Lane Court) will be added. It was also noted that several detailed specifications are missing from the bid documents, and several others are in the process of being revised. In addition, available soil boring information is missing together with a few applicable special details. As mentioned above, these items together with any others mentioned at today's conference along with those as a result of questions from prospective bidders will be addressed in Addendum 2, which is expected for release later this week.

VI. Questions

An inquiry was made regarding the amount of the current Engineer's Estimated Opinion of Cost for the project. The City stated the amount is approximately \$5.3 million.

Contact Information:

David Dykman
Project Manager
Phone: (734) 794-6410 ext. 43685
Fax: (734) 994-1744
E-mail: ddykman@a2gov.org

PRE-BID CONFERENCE SIGN-IN SHEET

PROJECT: STREET RESURFACING - 2016 (ITB No. 4422)

DATE: 03/07/2016

PLEASE PRINT

NAME	REPRESENTING	MAILING ADDRESS	TELEPHONE	EMAIL
David Dykman Project Manager	City of Ann Arbor - Project Management	Address: 301 E. Huron Street, P.O. Box 8647 City, State: Ann Arbor, MI Zip: 48107-8647	Office: (734) 794-6410, x43685 Mobile: Fax: (734) 994-1744	ddykman@a2gov.org
Gary Shively Civil Engineering Specialist (Project Inspector)	City of Ann Arbor - Project Management	Address: 301 E. Huron Street, P.O. Box 8647 City, State: Ann Arbor, MI Zip: 48107-8647	Office: (734) 794-6410, x43652 Mobile: Fax: (734) 994-1744	gshively@a2gov.org
David Clemons Supervisor - Civil Engineering Specialists	City of Ann Arbor - Project Management	Address: 301 E. Huron Street, P.O. Box 8647 City, State: Ann Arbor, MI Zip: 48107-8647	Office: (734) 794-6410, x43612 Mobile: Fax: (734) 994-1744	dclemons@a2gov.org
JIM McINNIS	DOAN	Address: 3670 CARPENTER RD City, State: YPSILANTI Zip: 48199	Office: () Mobile: 734) 323-3642 Fax No. ()	JMcINNIS@ DOANCOMPANIES .COM
MARK SCOTT	SPARTAN	Address: 9690 ANDERSONVILLE City, State: CLARKSTON Zip: 48346	Office: () Mobile: (313) 363-1532 Fax No. ()	MScott@ SPARTANPAVING.COM
DYLAN TAULBEE	SPARTAN	Address: 9690 ANDERSONVILLE RD City, State: CLARKSTON, MI Zip: 48197	Office: () Mobile: (734) 604-1256 Fax No. ()	dylan@spartanpaving.com
WANDA DWYER	CADILLAC	Address: 857 S. WAGNER RD City, State: ANN ARBOR, MI Zip: 48103	Office: () Mobile: (734) 216-7006 Fax No. (734) 1662-0439	wanda.dwyer@ mipmc.com
MICHAEL ANDREWS	MICHAEL ANDREWS CONCRETE	Address: 9561 CARSON HWY. City, State: TUCUMSEH MI Zip: 49286	Office: (517) 431-2091 Mobile: (734) 476-2180 Fax No. ()	MIKEANDREWS CONCRETE@YAHOO.COM

BID FORM

Section 1 - Schedule of Prices

Street Resurfacing - 2016
 File No. 2016-004
 Bid No. 4422

Item No.	<u>Item Description</u>	<u>Unit</u>	<u>Estimated Quantity</u>	<u>Unit Price</u>	<u>Total Price</u>
1047051	_General Conditions, Max \$75,000.00	LSUM	1.000	\$ _____	\$ _____
1047051	_Project Supervision, Max \$100,000.00	LSUM	1.000	\$ _____	\$ _____
2030011	Dr Structure, Rem	Ea	66.000	\$ _____	\$ _____
2030015	Sewer, Rem, Less than 24 inch	Ft	660.000	\$ _____	\$ _____
2047001	_Curb, Gutter, and Curb and Gutter, Any Type, Rem	Ft	15212.000	\$ _____	\$ _____
2047011	_Sidewalk, Sidewalk Ramp, and Driveway Approach, Any Thickness, Rem	Syd	3743.000	\$ _____	\$ _____
2047050	_Exploratory Excavation (0-10' Deep) Tr Det I	Ea	6.000	\$ _____	\$ _____
2050023	Granular Material, CI II	Cyd	60.000	\$ _____	\$ _____
2057011	_Grading, Driveway Approach	Syd	827.000	\$ _____	\$ _____
2057011	_Grading, Sidewalk	Syd	753.000	\$ _____	\$ _____
2057011	_Grading, Sidewalk Ramp	Syd	761.000	\$ _____	\$ _____
2057011	_Machine Grading, Special	Syd	37342.000	\$ _____	\$ _____
2057021	_Subgrade Undercutting, Type IIA	Cyd	9205.000	\$ _____	\$ _____
2057021	_Subgrade Undercutting, Type IIB	Cyd	1500.000	\$ _____	\$ _____
2080036	Erosion Control, Silt Fence	Ft	2500.000	\$ _____	\$ _____
2087050	_Erosion Control, Inlet Filter	Ea	214.000	\$ _____	\$ _____
2090001	Project Cleanup	LSUM	1.000	\$ _____	\$ _____
3010002	Subbase, CIP	Cyd	50.000	\$ _____	\$ _____
TOTAL THIS PAGE					\$ _____

BID FORM

Section 1 - Schedule of Prices

Street Resurfacing - 2016
 File No. 2016-004
 Bid No. 4422

<u>Item No.</u>	<u>Item Description</u>	<u>Unit</u>	<u>Estimated Quantity</u>	<u>Unit Price</u>	<u>Total Price</u>
3020001	Aggregate Base	Ton	1260.000	\$ _____	\$ _____
3020050	Aggregate Base, Conditioning	Syd	3500.000	\$ _____	\$ _____
3060020	Maintenance Gravel	Ton	350.000	\$ _____	\$ _____
3070001	Approach, CI I	Ton	250.000	\$ _____	\$ _____
3070101	Shoulder, CI I	Ton	150.000	\$ _____	\$ _____
3080010	Geotextile, Stabilization	Syd	100.000	\$ _____	\$ _____
4020987	Sewer, CI IV, 12 inch, Tr Det B	Ft	660.000	\$ _____	\$ _____
4021260	Trench Undercut and Backfill	Cyd	10.000	\$ _____	\$ _____
4030200	Dr Structure, 24 inch dia	Ea	58.000	\$ _____	\$ _____
4030306	Dr Structure, Tap, 6 inch	Ea	5.000	\$ _____	\$ _____
4037001	_Dr Structure, Adj, Add Depth, Modified	Ft	5.000	\$ _____	\$ _____
4037050	_Dr Structure Cover, Special	Ea	7.000	\$ _____	\$ _____
4037050	_Dr Structure Cover, Type B, Modified	Ea	107.000	\$ _____	\$ _____
4037050	_Dr Structure Cover, Type D, Modified	Ea	4.000	\$ _____	\$ _____
4037050	_Dr Structure Cover, Type K, Modified	Ea	102.000	\$ _____	\$ _____
4037050	_Dr Structure, Adj, Case 1, Modified	Ea	257.000	\$ _____	\$ _____
4037050	_Dr Structure, Adj, Case 2, Modified	Ea	5.000	\$ _____	\$ _____
4037050	_Dr Structure, Cleaning, Modified	Ea	25.000	\$ _____	\$ _____
TOTAL THIS PAGE					\$ _____

BID FORM

Section 1 - Schedule of Prices

Street Resurfacing - 2016
 File No. 2016-004
 Bid No. 4422

<u>Item No.</u>	<u>Item Description</u>	<u>Unit</u>	<u>Estimated Quantity</u>	<u>Unit Price</u>	<u>Total Price</u>
4037050	_Dr Structure, Double Inlet	Ea	8.000	\$ _____	\$ _____
4037050	_Dr Structure, Point	Ea	7.000	\$ _____	\$ _____
4037050	_Dr Structure, Reconstruct	Ea	1.000	\$ _____	\$ _____
4037050	_Dr Structure, Temp Lowering, Modified	Ea	212.000	\$ _____	\$ _____
4047001	_Underdrain, Subgrade, 6 inch, Special	Ft	3000.000	\$ _____	\$ _____
5010001	Pavt, Cleaning	LSUM	1.000	\$ _____	\$ _____
5010003	Cold Milling HMA Surface	Ton	21186.000	\$ _____	\$ _____
5010005	HMA Surface, Rem	Syd	2525.000	\$ _____	\$ _____
5010015	Joint and Crack, Cleanout	Ft	2500.000	\$ _____	\$ _____
5010025	Hand Patching	Ton	172.500	\$ _____	\$ _____
5010051	HMA, 4E3	Ton	2735.000	\$ _____	\$ _____
5010057	HMA, 5E3	Ton	9428.000	\$ _____	\$ _____
5010061	HMA, Approach	Ton	636.000	\$ _____	\$ _____
5010703	HMA, LVSP	Ton	8388.000	\$ _____	\$ _____
5017011	_HMA, Raised Crosswalk	Syd	60.000	\$ _____	\$ _____
5017011	_HMA, Raised Intersection	Syd	175.000	\$ _____	\$ _____
5017011	_HMA, Speed Hump	Syd	35.000	\$ _____	\$ _____
5017031	_HMA, Wedging, 36A	Ton	8.000	\$ _____	\$ _____
TOTAL THIS PAGE					\$ _____

BID FORM

Section 1 - Schedule of Prices

Street Resurfacing - 2016
 File No. 2016-004
 Bid No. 4422

Item No.	<u>Item Description</u>	<u>Unit</u>	<u>Estimated Quantity</u>	<u>Unit Price</u>	<u>Total Price</u>
5017050	HMA Surface, Around Structure Cover, Rem	Ea	24.000	\$ _____	\$ _____
6027021	_Flowable Fill	Cyd	563.963	\$ _____	\$ _____
6030005	Cement	Ton	59.000	\$ _____	\$ _____
8017011	_Driveway, Nonreinf Conc, 6 inch, Modified	Syd	779.000	\$ _____	\$ _____
8017011	_Driveway, Nonreinf Conc, 8 inch, Modified	Syd	48.000	\$ _____	\$ _____
8027001	_Curb and Gutter, Conc	Ft	11503.000	\$ _____	\$ _____
8027001	_Driveway Opening, Conc, Det M, Modified	Ft	3342.000	\$ _____	\$ _____
8037001	_Detectable Warning Surface, Modified	Ft	420.000	\$ _____	\$ _____
8037001	_Fence, Protective, Modified	Ft	250.000	\$ _____	\$ _____
8037010	_Sidewalk Ramp, Conc, 6 inch, Modified	Sft	6815.000	\$ _____	\$ _____
8037010	_Sidewalk Retaining Wall, Integral, 6 inch to 18 inch Height	Sft	65.000	\$ _____	\$ _____
8037010	_Sidewalk Retaining Wall, Integral, Less than 6 inch Height	Sft	15.000	\$ _____	\$ _____
8037010	_Sidewalk, Conc or Clay Brick Pavers, Rem and Reinstall	Sft	25.000	\$ _____	\$ _____
8037010	_Sidewalk, Conc, 4 inch, Modified	Sft	5890.000	\$ _____	\$ _____
8037010	_Sidewalk, Conc, 6 inch, Modified	Sft	824.900	\$ _____	\$ _____
8110049	Pavt Mrkg, Ovly Cold Plastic, Direction Arrow Sym, Bike	Ea	38.000	\$ _____	\$ _____
8110058	Pavt Mrkg, Ovly Cold Plastic, Bike, Small Sym	Ea	38.000	\$ _____	\$ _____
8110079	Pavt Mrkg, Ovly Cold Plastic, Sharrow Symbol	Ea	1.000	\$ _____	\$ _____
TOTAL THIS PAGE					\$ _____

BID FORM

Section 1 - Schedule of Prices

Street Resurfacing - 2016
 File No. 2016-004
 Bid No. 4422

<u>Item No.</u>	<u>Item Description</u>	<u>Unit</u>	<u>Estimated Quantity</u>	<u>Unit Price</u>	<u>Total Price</u>
8110153	Pavt Mrkg, Sprayable Thermopl, 4 inch, White	Ft	3917.000	\$ _____	\$ _____
8110154	Pavt Mrkg, Sprayable Thermopl, 4 inch, Yellow	Ft	56072.000	\$ _____	\$ _____
8110155	Pavt Mrkg, Sprayable Thermopl, 6 inch, White	Ft	41559.000	\$ _____	\$ _____
8110197	Pavt Mrkg, Thermopl, 6 inch, Crosswalk	Ft	2621.000	\$ _____	\$ _____
8110212	Pavt Mrkg, Thermopl, 12 inch, Cross Hatching, White	Ft	225.000	\$ _____	\$ _____
8110213	Pavt Mrkg, Thermopl, 12 inch, Cross Hatching, Yellow	Ft	36.000	\$ _____	\$ _____
8110218	Pavt Mrkg, Thermopl, 24 inch, Stop Bar	Ft	978.000	\$ _____	\$ _____
8110332	Rem Raised Pavt Marker	Ea	25.000	\$ _____	\$ _____
8110343	Rem Spec Mrkg	Sft	250.000	\$ _____	\$ _____
8117001	_Pavt Mrkg, Thermopl, 24 inch, Crosswalk	Ft	1536.000	\$ _____	\$ _____
8117050	_Pavt Mrkg, Thermopl, Lt Turn Arrow Sym	Ea	11.000	\$ _____	\$ _____
8117050	_Pavt Mrkg, Thermopl, Only	Ea	13.000	\$ _____	\$ _____
8117050	_Pavt Mrkg, Thermopl, Railroad Sym	Ea	1.000	\$ _____	\$ _____
8117050	_Pavt Mrkg, Thermopl, Rt Turn Arrow Sym	Ea	6.000	\$ _____	\$ _____
8117050	_Pavt Mrkg, Thermopl, School	Ea	3.000	\$ _____	\$ _____
8117050	_Pavt Mrkg, Thermopl, Speed Hump Chevron, White	Ea	1.000	\$ _____	\$ _____
8120012	Barricade, Type III, High Intensity, Double Sided, Lighted, Furn	Ea	106.000	\$ _____	\$ _____
8120013	Barricade, Type III, High Intensity, Double Sided, Lighted, Oper	Ea	106.000	\$ _____	\$ _____
TOTAL THIS PAGE					\$ _____

BID FORM

Section 1 - Schedule of Prices

Street Resurfacing - 2016
 File No. 2016-004
 Bid No. 4422

<u>Item No.</u>	<u>Item Description</u>	<u>Unit</u>	<u>Estimated Quantity</u>	<u>Unit Price</u>	<u>Total Price</u>
8120030	Channelizing Device, 42 inch, Furn	Ea	500.000	\$ _____	\$ _____
8120031	Channelizing Device, 42 inch, Oper	Ea	500.000	\$ _____	\$ _____
8120140	Lighted Arrow, Type C, Furn	Ea	6.000	\$ _____	\$ _____
8120141	Lighted Arrow, Type C, Oper	Ea	14.000	\$ _____	\$ _____
8120210	Pavt Mrkg, Longit, 6 inch or Less Width, Rem	Ft	250.000	\$ _____	\$ _____
8120220	Pavt Mrkg, Type NR, Paint, 4 inch, White, Temp	Ft	20000.000	\$ _____	\$ _____
8120221	Pavt Mrkg, Type NR, Paint, 4 inch, Yellow, Temp	Ft	2800.000	\$ _____	\$ _____
8120240	Pavt Mrkg, Type R, 4 inch, White, Temp	Ft	1500.000	\$ _____	\$ _____
8120241	Pavt Mrkg, Type R, 4 inch, Yellow, Temp	Ft	2000.000	\$ _____	\$ _____
8120260	Plastic Drum, High Intensity, Lighted, Furn	Ea	1579.000	\$ _____	\$ _____
8120261	Plastic Drum, High Intensity, Lighted, Oper	Ea	1579.000	\$ _____	\$ _____
8120330	Sign, Portable, Changeable Message, Furn	Ea	8.000	\$ _____	\$ _____
8120331	Sign, Portable, Changeable Message, Oper	Ea	21.000	\$ _____	\$ _____
8120350	Sign, Type B, Temp, Prismatic, Furn	Sft	4829.250	\$ _____	\$ _____
8120351	Sign, Type B, Temp, Prismatic, Oper	Sft	4829.250	\$ _____	\$ _____
8120370	Traf Regulator Control	LSUM	1.000	\$ _____	\$ _____
8127050	_No Parking Sign	Ea	551.000	\$ _____	\$ _____
8127051	_Minor Traffic Control, Max \$50,000.00	LSUM	1.000	\$ _____	\$ _____
TOTAL THIS PAGE					\$ _____

BID FORM

Section 1 - Schedule of Prices

Street Resurfacing - 2016
 File No. 2016-004
 Bid No. 4422

Item No.	<u>Item Description</u>	<u>Unit</u>	<u>Estimated Quantity</u>	<u>Unit Price</u>	<u>Total Price</u>
8157060	_Irrigation System, Protection and Maintenance	Dir	2500.000	\$ _____	\$ _____
8167011	_Slope Restoration	Syd	5587.000	\$ _____	\$ _____
8190159	Conduit, Schedule 80, 3 inch	Ft	100.000	\$ _____	\$ _____
8197050	_Handhole Assembly, 12 Inch X 18 Inch	Ea	2.000	\$ _____	\$ _____
8197050	_Handhole Assembly, 17 Inch X 30 Inch	Ea	1.000	\$ _____	\$ _____
8217050	_Monument Box Adjust	Ea	5.000	\$ _____	\$ _____
8230431	Gate Box, Adj, Case 1	Ea	30.000	\$ _____	\$ _____
8230432	Gate Box, Adj, Case 2	Ea	1.000	\$ _____	\$ _____
TOTAL THIS PAGE					\$ _____
TOTAL FROM PAGE ADD-3-8					\$ _____
TOTAL FROM PAGE ADD-3-9					\$ _____
TOTAL FROM PAGE ADD-3-10					\$ _____
TOTAL FROM PAGE ADD-3-11					\$ _____
TOTAL FROM PAGE ADD-3-12					\$ _____
TOTAL FROM PAGE ADD-3-13					\$ _____
TOTAL BASE BID					\$ _____

CITY OF ANN ARBOR

NOTICE TO BIDDERS

AA:DAD

1 of 2

03/15/16

Utilities Coordination

The Contractor shall cooperate and coordinate construction activities with the owners of utilities as stated in subsection 104.08 of the Standard Specifications for Construction. In addition, for the protection of underground utilities, the Contractor shall follow the requirements in subsection 107.12 of the Standard Specifications for Construction. Contractor delay claims resulting from a utility will be determined based upon subsection 108.09 of the Standard Specifications for Construction.

The following Utility Owners, together with others, may have facilities located within the Right-of-Way:

<u>Utility</u>	<u>Type of Service</u>
City of Ann Arbor W.R. Wheeler Service Center 4251 Stone School Road Ann Arbor, MI 48108 734 794-6351	Sanitary Sewer (Mark Cozart - ext. 43318) Water (Daniel Wooden - ext. 43324) Storm Sewer (Matthew Waldsmith - ext. 43321) Communications/Signs/Signals/Street Lighting (Chuck Fojtik - ext. 43322)
AT&T 550 South Maple Ann Arbor, MI 48103 Attn: Debora Renner 734-996-5485 debora.a.renner@att.com	Telephone/Fiber Optic
Comcast 27800 Franklin Road Southfield, MI 48034 Attn: Ron Southerland 248-359-6544 ronald_southerland@cable.comcast.com	Cable/Fiber Optic
DTE Energy 2000 2 nd Ave, Room 518 S.B. Detroit, MI 48226 Attn: Julie Gottardi 734-884-0585 gottardij@dteenergy.com	Electric
DTE Energy (Michcon) 17150 Allen Road Melvindale, MI 48122 Attn: Laurie Forrester 313-389-7261 forresterl@dteenergy.com	Gas

UtilityType of Service

MCI/Verizon
5688 W Grand River Avenue
Lansing, MI 48906
Attn: Rick Chalmers
517-318-8064
rick.chalmers@verizonbusiness.com

Telephone/Fiber Optic

For protection of underground utilities, the Contractor shall call "MISS DIG" toll free at 1-800-482-7171 or call 811 a minimum of three (3) working days prior to excavation within the project limits. The Contractor must also notify utility owners who may not be part of the "MISS DIG" system.

The Contractor shall notify the City of Ann Arbor a minimum of three (3) days prior to beginning construction.

The Owners of public or private utilities which will not interfere with the completed project and which do not present a hazard to the public or an extraordinary hazard to the Contractor's operations will not be required to move their facilities on or from the street right-of-way.

The Contractor shall verify the location and depth of all utilities through Miss Dig and coordinate with the utilities to ensure that all utilities are protected during the project.

Protection of existing utility facilities is necessary during the project. Protection may include: holding utility poles, supporting underground facilities, temporary sheeting, bracing, poles, cables, sand fill or other means to complete the work. The Contractor is responsible for furnishing all labor, equipment and materials required to protect existing facilities during construction. Costs associated with protecting existing utilities will not be paid for separately.

CITY OF ANN ARBOR
DETAILED SPECIFICATION
FOR
GENERAL CONDITIONS

AA:DAD

1 of 2

03/15/16

a. Description. This item shall include all work described and required by the Plans and Specifications at each location for which no item of work is listed in the Bid Form, including but not limited to:

- Scheduling, coordination, and organization of all work, subcontractors, suppliers, testing, inspection, surveying, and staking.
- Coordination of, and cooperation with, other contractors, agencies, departments, and utilities.
- Protection and maintenance of utilities.
- Maintaining drainage.
- Maintaining driveways drive openings, sidewalks, bike paths, mail deliveries, and solid waste/recycle pick-ups. This includes the placement and maintenance of gravel in driveway openings as directed by the Engineer.
- Storing all materials and equipment off lawn areas.
- Temporary relocation and final replacement/re-setting of mailboxes.
- Coordination efforts to furnish various HMA mixtures as directed by the Engineer
- Coordination efforts to furnish and operate various-size vehicles/equipment as directed by the Engineer
- Furnishing and operating vacuum-type street cleaning equipment a minimum of once per week or more frequently as directed by the Engineer
- Furnishing and operating vacuum-type utility structure cleaning equipment
- Furnishing and operating both vibratory plate and pneumatic-type (“pogo-stick”) compactors
- Furnishing and operating a backhoe during all work activities
- Furnishing and operating a jackhammer and air compressor during all work activities
- Noise and dust control
- Mobilization(s) and demobilization(s).
- Furnishing submittals and certifications for materials and supplies
- All miscellaneous and incidental items such as overhead, insurance, and permits.
- Meeting all requirements relating to Debarment Certification, Davis Bacon Act, and Disadvantaged Business Enterprise, and providing the necessary documentation.

Data pertaining to existing soil borings and pavement sections, which are included in the Appendix of these Contract Documents, are provided to help the Engineer and Contractor determine the soil conditions existing within the construction area. The City in no way

guarantees existing conditions to be the same as shown in the data. The Contractor is solely responsible for any and all conclusions he/she may draw from the data.

Quantities as given are approximate and are estimated for bidding purposes. Quantities are not guaranteed and may vary by any amount. While it is the City's intent to complete the project substantially as drawn and specified herein, quantities may be changed or reduced to zero for cost savings or other reasons. **The City reserves the right to change the quantities, and no adjustment in unit price will be made for any change in any quantity.**

b. Materials. None Specified.

c. Construction. Not specified.

d. Measurement and Payment. The completed work, as described, will be measured and paid for at the contract unit price for the following pay item:

<u>Pay Item</u>	<u>Pay Unit</u>
General Conditions, Max \$_____	Lump Sum

This item of work will be paid for on a pro rata basis at the time of each progress payment. Measurement will be based on the ratio between work completed during the payment period and the total contract amount. When all of the work of this Contract has been completed, the measurement of this item shall be 1.0 Lump Sum, minus any deductions incurred for inadequate performance as described herein. This amount will not be increased for any reason, including extensions of time, extras, and/or additional work.

The unit price for this item of work shall include all labor, material, and equipment costs to perform all the work specified in the Standard Specifications and as modified by this Detailed Specification.

CITY OF ANN ARBOR
DETAILED SPECIFICATION
FOR
PROJECT SCHEDULE

AA:DAD

1 of 2

03/15/16

The entire work under this Contract shall be completed in accordance with, and subject to, the scheduling requirements as outlined below, and all other requirements of the Contract Documents.

The Contractor shall organize, coordinate and diligently execute the work at the locations shown on the Schedule of Streets included herein, which details the requirements, if any, for Start of Work, Completion of Work, Restricted Dates, and the Maximum Calendar Days for Completion, and the Liquidated Damages per Calendar Day for each street. For the purpose of this Contract, "Start of Work" is defined as the date of installation of the "No-Parking" signs. "Completion of Work" is defined as the completion of the work as specified herein and as directed by the Engineer (including, but not limited to, driveway wedging, surface restoration, clean-up, street cleaning, underground utility and utility structure cleaning, and the removal of all temporary traffic control devices and "No Parking" signs).

The Engineer shall limit the Contractor's work operations to a number of streets that, in the opinion of the Engineer, is reasonable to allow for proper and thorough inspection, and to reduce traffic control and/or safety problems. The contractor shall not have more than four (4) locations "active" at any given time with a maximum of three (3) of those locations being Major Streets. A location is considered "active" if work on the street has begun; however, it has not yet been completed. Combined streets are regarded as one (1) location.

The Contractor is expected to be furnished with two (2) copies of the Contract, for its execution, on or before **April 19, 2016**. The Contractor shall properly execute both copies of the Contract and return them, with the required Bonds and Insurance documentation, to the City by **April 29, 2016**. The Contractor shall not begin the work before the applicable date(s) as described herein without approval from the Project Engineer, and in no case before the receipt of the fully executed Contract and Notice to Proceed.

By no later than **April 25, 2016** the Contractor shall submit a detailed schedule of work (progress schedule) for the Engineer's review and approval. The progress schedule must fully comply with the scheduling requirements contained on the Street List & Schedule in this Detailed Specification. The schedule shall clearly indicate, in detail, the start and the finish date of each work task on each street. Work shall not start until the progress schedule is approved in writing by the Engineer. The Contractor shall update the approved progress schedule each week, and present it to the Engineer at the weekly progress meeting, and must consult with the Engineer daily, for his/her review, and gain his/her approval, of any proposed deviations from the most current, approved, schedule.

The Contractor shall begin the work of this project on or before **May 9, 2016**, and only upon receipt of the fully executed Contract and Notice to Proceed. Appropriate time extensions shall be granted if the Notice to Proceed is delayed beyond this date.

The entire project shall be completed on or before **October 22, 2016**. The contract is considered complete when the project is ready for use and all restoration and pavement markings have been completed.

Failure to complete all work as specified herein within the times specified herein, including time extensions granted thereto as determined by the Engineer, shall entitle the City to deduct from

the payments due the Contractor, the dollar amounts specified in the Street List & Schedule as "Liquidated Damages" for delays in the completion of the work for each incomplete street, for each and every calendar day.

Time is of the essence in the performance of the work of this contract. The Contractor is expected to mobilize sufficient personnel and equipment and work throughout all authorized hours to complete the project by the final completion date. Should the Contractor demonstrate that they must work on some Sundays in order to maintain the project schedule, they may do so between the hours of 9:00 a.m. and 5:00 p.m. with prior approval from the City. There will be no additional compensation due to the Contractor for work performed on Sundays.

The Engineer may delay or stop the work due to threatening weather conditions. The Contractor shall not be compensated for unused materials or downtime due to rain, or the threat of rain. The Contractor is solely responsible for repairing all damages to the work and to the site, including road infrastructures, road subgrades, and any adjacent properties, which are caused as a result of working in the rain.

The Contractor shall not work in the dark except as approved by the Engineer and only when lighting for night work is provided as detailed elsewhere in this contract. The Engineer may stop the work, or may require the Contractor to defer certain work to another day, if, in the Engineer's opinion, the work cannot be completed within the remaining daylight hours, or if inadequate daylight is present to either properly perform or inspect the work. The Contractor will not be compensated for unused materials or downtime, when delays or work stoppages are directed by the Engineer for darkness and/or inadequate remaining daylight reasons. The Contractor is solely responsible for repairing all damages to the work and to the site, including road infrastructures, road subgrades, and any adjacent properties, which are caused as a result of working in the dark.

Liquidated Damages will be assessed until the required work is completed in the current construction season. If, with the Engineer's approval, work is extended beyond seasonal limitations, the assessment of Liquidated Damages will be discontinued until the work is resumed in the following construction season.

If the construction contract is not completed within the specified period(s) including any extensions of time granted thereto, at the sole discretion of the City of Ann Arbor, this Contract may be terminated with no additional compensation due to the Contractor, and the Contractor may be forbidden to bid on future City of Ann Arbor projects for a period of at least three (3) years. If the Engineer elects to terminate the Contract, contract items paid for on a Lump Sum basis shall be paid up to a maximum percentage equal to the percentage of the contract work that has been completed.

The City's decision to delete streets, add streets, change the construction limits on streets, or, the City's contribution to a delay of the construction on any one street shall not entitle the Contractor to receive additional compensation for work on any other street(s), nor shall it relieve the Contractor of any responsibilities for completion of work on any other street(s).

Costs for the Contractor to organize, coordinate, and schedule all of the project work will not be paid for separately, but shall be included in the bid price of the Contract Item "General Conditions, Max \$____"

Street Resurfacing – 2016

Schedule of Streets

Location (Street)	Limits of Work	Start of Work	Completion of Work	Restricted Dates	Maximum Calendar Days for Completion	Liquidated Damages per Calendar Day
MAJOR STREETS						
Depot Street	N Main St to Carey St			AAAF, UMFB	36	\$1,000.00
Dexter Avenue	City Limit to Maple Rd			AAAF	30	\$1,000.00
Dhu Varren Road	Pontiac Tr to RR Xing				21	\$750.00
Eisenhower Parkway/ Packard Road	Stone School Rd to Packard Rd			AAAF, UMFB	30	\$1,000.00
Green Road	Nixon Rd to Burbank Dr/ Gettysburg Rd				48	\$750.00
Huron River Drive	Bird Rd to N Main St			MDOT, UMFB	14	\$750.00
Maiden Lane	Maiden Lane Ct to Island Dr			UM, UMGW	21	\$1,000.00
Pauline Boulevard	S Maple Rd to W Stadium Blvd				24	\$750.00
Pontiac Trail	John A Woods Dr to Skydale Dr			MDOT	42	\$750.00

AAPS - No work permitted when Ann Arbor Public Schools are in session (before June 17, 2016 or after September 1, 2016).

AAAF - No work permitted from July 21, 2016 thru July 24, 2016 due to Ann Arbor Art Fair.

MDOT - No work permitted until the MDOT M-14 project is open to traffic or before September 6, 2016, whichever occurs soonest.

UM - No work permitted when University of Michigan Spring/Fall semesters are in session (before April 28, 2016 or after September 6, 2016).

UMFB - No work permitted on University of Michigan home football game days.

UMGW - No work permitted during University of Michigan Graduation Weekend (April 28, 2016 thru May 1, 2016).

Street Resurfacing – 2016

Schedule of Streets

Location (Street)	Limits of Work	Start of Work	Completion of Work	Restricted Dates	Maximum Calendar Days for Completion	Liquidated Damages per Calendar Day
MINOR (LOCAL) STREETS						
Birch Hollow Drive	Stone School Rd to Chelsea Cir (south)		To be combined		26	\$500.00
Birch Hollow Drive	Chelsea Cir (north) to Mary Beth Doyle Park Entrance					
Brentwood Court	End (cul-de-sac) to King George Blvd		To be combined		26	\$500.00
Wexford Court	End (cul-de-sac) to King George Blvd					
North Baylis Drive	End (cul-de-sac) to Beaconsfield Dr		To be combined		38	\$500.00
Beaconsfield Drive	Pebble Creek Rd to N Baylis Dr					
Pebble Creek Road	Birch Hollow Dr to Stone School Rd		To be combined		42	\$500.00
Catalpa Court	Pebble Creek Dr to Pebble Creek Dr					
Quail Hollow Court	End (cul-de-sac) to Pebble Creek Dr					
Tacoma Circle	King George Blvd to King George Blvd		To be combined		40	\$500.00
Sussex Court	End (cul-de-sac) to Tacoma Cir					
Page Avenue	End (cul-de-sac) to King George Blvd				16	\$500.00
Ticknor Court	End (cul-de-sac) to Stone School Rd				24	\$500.00

AAPS - No work permitted when Ann Arbor Public Schools are in session (before June 17, 2016 or after September 1, 2016).

AAAF - No work permitted from July 21, 2016 thru July 24, 2016 due to Ann Arbor Art Fair.

MDOT - No work permitted until the MDOT M-14 project is open to traffic or before September 6, 2016, whichever occurs soonest.

UM - No work permitted when University of Michigan Spring/Fall semesters are in session (before April 28, 2016 or after September 6, 2016).

UMFB - No work permitted on University of Michigan home football game days.

UMGW - No work permitted during University of Michigan Graduation Weekend (April 28, 2016 thru May 1, 2016).

CITY OF ANN ARBOR
DETAILED SPECIFICATION
FOR
MACHINE GRADING

AA:DAD

1 of 6

03/15/16

a. Description. Machine grading shall be completed in accordance with section 205 of the Michigan Department of Transportation (MDOT) 2012 Standard Specifications for Construction as shown on the plans, and as specified herein, with the exception that subgrade undercutting shall be paid for separately for applicable work when this pay item is included in the proposal. Machine grading shall include all the work specified herein for which there is no separate pay item. This work shall consist of constructing earth grades by excavating, cutting, filling, trimming, and grading; general restoration, and sign removals in accordance with the Detailed Specifications elsewhere herein; and maintaining the work in a finished condition until such time that it is accepted by the Engineer.

b. Materials. All materials shall meet the requirements as specified in section 205 of the MDOT 2012 Standard Specifications for Construction, except as specified herein.

c. Construction. All construction methods shall meet the requirements as specified in section 205 of the MDOT 2012 Standard Specifications for Construction, except as specified herein.

1. Soils Information - Soil information provided as part of the contract documents is for informational purposes only and shall not relieve the Contractor of the responsibility of investigating all local conditions before bidding.
2. General Provisions - The Contractor shall:
 - A. Grade around mailboxes, trees, light poles, power poles, and the like, which are to remain in place. The Contractor shall be responsible for any damage caused to such structures.
 - B. Maintain the work in a finished condition until it is accepted by the Engineer.
3. Pavement Sawcutting - The work shall include the full-depth saw-cutting of pavement at the construction limits, and elsewhere as required, if not paid for as part of another item of work. Pavement sawcutting will not be paid for separately.
4. Removal of Trees and Vegetation - The Contractor shall remove and properly dispose of off-site all vegetation; brush; roots; and trees and stumps less than 6 inch in diameter, as shown on the plans, and as directed by the Engineer as required to complete the project.
5. Removal and Salvaging of Topsoil - The removal, salvaging and stockpiling of topsoil, and all related work, shall be performed in accordance with subsection 205.03.A.1 (Removing and Salvaging Topsoil) of the MDOT 2012 Standard Specifications for Construction and will not be paid for separately.
6. Miscellaneous Removals - The removal of HMA, aggregate, and/or concrete materials from around manholes, structures, and utility covers, and the removal of HMA curbing, HMA driveway wedges, HMA surface on existing curb and gutter, and HMA surfaces required for removal in other miscellaneous areas shall be paid for as "Machine Grading, Special" and will not be paid for separately unless there are items in the contract specific to these types of work.

“Machine Grading, Special” includes the removal of any surface feature located within the grading limits which must be removed and for which there is no specific pay item established in the proposal for its removal.

7. Protection of the Grade - The work shall be kept well drained at all times. Foundation, roadway embankment or subgrade that becomes damaged by rain shall be undercut and backfilled, or otherwise remedied, by the Contractor, at his/her sole expense, as directed by the Engineer.

The Contractor shall be responsible for the maintenance of the foundation, roadway embankment, and subgrade. Any damage caused, by traffic or the Contractor's operations, to the foundation, roadway embankment or subgrade, in the opinion of the Engineer, shall be remedied by the Contractor at his/her sole expense, as directed by the Engineer.

The Contractor shall not use rubber-tired equipment on the foundation, roadway embankment, or subgrade, when its use causes, in the opinion of the Engineer, unnecessary damage to the foundation, road embankment or subgrade. The Contractor shall conduct his/her operations and provide the necessary equipment to ensure the satisfactory completion of the work without damaging the foundation, roadway embankment or subgrade. This may require the transporting and movement of materials over additional distances.

At various times throughout the work, the Engineer may direct the Contractor to use smaller and/or lighter equipment, and to defer certain work tasks, in order to protect the grade and/or adjacent areas. The Contractor shall not be entitled to an extension of time or any additional compensation for the use of smaller equipment, lighter equipment, or work task deferral.

8. Removal of Cable, Conduits and Pipe - The Contractor shall remove, and properly dispose of off-site, all abandoned cables, conduit, and pipe encountered at, or above the bottom of any earthwork excavation or undercut. Where the inverts of abandoned, or to be abandoned or removed, conduits or pipe are less than 16 inches below the bottom of any earth excavation or undercut, the conduits and/or pipe shall be removed and the resulting void filled with an Engineer approved material. The fill material shall be compacted to 95% of its maximum unit weight in lifts not exceeding 12 inches. No separate payment will be made for removal of conduit or pipe, or any of the work, described in this section.

9. Foundation Preparation - Foundation is defined as the original earth grade upon which roadway embankment is placed. The foundation work shall be completed in accordance with subsection 205.03.A (Preparing Roadway Foundation) of the MDOT 2012 Standard Specifications for Construction as shown on the plans, and as specified herein.

The foundation shall be compacted to 95% of its maximum unit weight, as measured by the AASHTO T-180 method, to a depth of at least 10 inches. If this cannot be achieved, in the opinion of the Engineer, he/she will direct the Contractor to perform “Subgrade Undercutting, Type ___” or “Subgrade Manipulation,” as described herein, on the foundation.

10. Roadway Embankment Construction - Roadway embankment is defined as the construction of earth on the prepared foundation to form the subgrade. Roadway embankment work shall be completed in accordance with subsection 205.03 H (Roadway Embankment) of the MDOT 2012 Standard Specifications for Construction as shown on the

plans, and as specified herein. Roadway embankment shall be compacted to a minimum of 95% of its maximum unit weight, as measured by the AASHTO T-180 method.

11. Subgrade Construction - Subgrade is defined as the final earth grade which extends from grading limit to grading limit. The subgrade shall be constructed by performing earth excavation and roadway embankment work in accordance with subsection 205.03.G (Earth Excavation) and subsection 205.03 H (Roadway Embankment) of the MDOT 2012 Standard Specifications for Construction, as shown on the plans, and as specified herein.

The subgrade shall be constructed to the contours and cross-sections shown on the plans, as specified herein, and as directed by the Engineer. To achieve this, the work shall include, but not be limited to:

- A. Removal and disposal off-site of any surplus or unsuitable materials.
- B. Furnishing from off-site any additional Engineer approved fill materials necessary.
- C. Moving existing and/or furnished materials longitudinally and transversely as necessary.
- D. Cutting, placing, compacting, and trimming existing and/or furnished materials to construct the roadway embankment and subgrade to the specified tolerances.
- E. Stockpiling, and moving again, any cut materials which cannot be immediately placed upon excavation due to construction staging.

The subgrade shall be graded to accommodate all subbases and aggregate bases wherever used, all bioswale and adjacent planting beds, all roadway pavements, curb and gutter, driveways, sidewalks, bicycle paths, other similar structures, bioswale planting mix, topsoil and any other features which the subgrade supports.

The subgrade shall be prepared so as to ensure uniform support for the pavement structure. The finished subgrade shall be placed to within 1 inch below and $\frac{3}{4}$ inch above plan grade. Variations within this tolerance shall be gradual.

The subgrade shall be compacted to a minimum of 95% of its maximum unit weight, as measured by the AASHTO T-180 method, to a depth of 10 inches. If this cannot be achieved, in the opinion of the Engineer, he/she will direct the Contractor to perform "Subgrade Undercutting, Type ___" or "Subgrade Manipulation" as described herein.

The Contractor shall use equipment and methods of construction best suited, in the opinion of the Engineer, to the earthwork operations being performed and the project requirements. The use of various equipment and methods of construction are subject to the approval of the Engineer. The Engineer may disallow the use of certain equipment and methods of construction and require the use of other equipment and/or methods of construction. No additional compensation or extensions of contract time will be allowed for additional measures that are required for the protection of the grade as specified herein.

13. Test Rolling - The Contractor shall test-roll the foundation and/or subgrade with a pneumatic tired roller with a suitable body for ballast loading and a gross load capacity that can be varied from 25 and 40 tons. In lieu of this test roller, with the approval of the Engineer, the Contractor may use a fully loaded single axle or tandem axle dump truck.

14. Subgrade Undercutting - "Subgrade Undercutting" shall be performed on the foundation or subgrade in accordance with section 205.03.E (Subgrade Undercutting) of the MDOT

2012 Standard Specifications for Construction, as shown on the plans, as specified herein, and as directed by the Engineer.

15. Subgrade Manipulation - "Subgrade Manipulation" shall be performed on the foundation or subgrade in accordance with section 205.03.F (Subgrade Manipulation) of the MDOT 2012 Standard Specifications for Construction, as shown on the plans, as specified herein, and as directed by the Engineer.

Where subgrade manipulation is required, the foundation or subgrade shall be thoroughly scarified, blended, and mixed to a depth of 12 inches. The work shall be accomplished by means of a large diameter disc, motor grader, or other equipment approved by the Engineer.

After the foundation or subgrade has been manipulated to the satisfaction of the Engineer and allowed to dry, the soil shall be compacted to 95% of its maximum dry density as measured by the AASHTO T-180 method. The time required for drying the soil will not be a basis for an extension of time.

The cost of Subgrade Manipulation shall be included in the cost of "Machine Grading, Special" unless a pay item for "Subgrade Manipulation" is included in the Contract documents.

16. Rock Excavation - Rock excavation shall be performed in accordance with section 205.03.B (Rock Excavation) of the MDOT 2012 Standard Specifications for Construction, as shown on the plans, and as directed by the Engineer.

The pay item "Rock Excavation" will apply only to boulders over ½ cubic yard in volume. Boulders will be measured individually and the volume computed from the average dimension measured in three directions. The removal of rocks, concrete and masonry less than ½ cubic yard in volume shall not be included in the pay item "Rock Excavation," but shall be included in the pay item "Machine Grading, Special."

If the proposal does not include a pay item for "Rock Excavation," rocks measuring over ½ cubic yard in volume shall be paid for as extra work.

17. Lowering Structures - Prior to cutting the subgrade, the Contractor shall remove structure covers, lower the structures to a point between 8 inches and 12 inches below the proposed subgrade, and cover the structures with a steel plate. Structures shall not be raised prior to placing roadway embankment.

The steel plates for covering structure openings shall conform to the plan detail, be pegged and properly placed to prevent their movement under all traffic, be thick enough to carry all traffic, and prevent the infiltration of debris into the structures.

The Contractor shall lower valve boxes to a point between 8 inches and 12 inches below the proposed subgrade. Valve boxes shall not be raised prior to placing roadway embankment.

The void in the grade above the steel plates used for structure lowering and valve box lowering shall be backfilled, and compacted to 95% of its maximum dry density, with an Engineer approved coarse aggregate.

The Contractor shall coordinate the lowering of private utility structures with the private utility companies.

18. Structure Covers - As directed by the Engineer and within two days of their removal, the Contractor shall stockpile on-site, in a location that is mutually agreeable to the Engineer and Contractor, the existing structure covers. The City of Ann Arbor's forces will pick-up the structure covers at a time that is convenient to them and mutually agreeable to the Contractor. The Contractor shall provide the equipment and manpower to load the castings on the City's vehicle(s) so that they can be removed from the site by the City.

19. Structure and Sewer Cleanliness - All sewers, and structures, including manholes, gate wells, valve boxes, inlet structures and curbs shall be protected from damage and contamination by debris and construction materials. Structures shall be maintained clean of construction debris and properly covered at all times during the construction. The Contractor shall immediately clean any structures and/or sewers that become contaminated with construction debris. The Contractor shall be responsible for all direct and indirect damages which are caused by sewers or structures which have been made unclean or have been damaged by the Contractor.

20. Tree trimming - The Contractor shall coordinate with the City Field Services Unit to schedule trimming of trees by City forces or authorized subcontractor. The Contractor shall not be entitled to an extension of time or any additional compensation for the coordination of this work.

d. Measurement and Payment. The completed work, as described, will be measured and paid for at the contract unit price for the following pay item:

<u>Pay Item</u>	<u>Pay Unit</u>
Machine Grading, Special.....	Square Yard

Measurement for payment for the item **Machine Grading, Special** shall be the computed in square yard quantity of excavated material (soil, rock, brick, etc.) from the top of existing grade down to the bottom of the excavation. Embankment, fill, subgrade protection/maintenance/manipulation, and drainage maintenance will not be paid for separately, and are included in this item of work.

Machine Grading, Special will be measured in area of the feature being constructed by the unit square yard, and include all labor, materials and equipment required to complete the work.

The Contractor shall include all of its costs to complete all of the work in the **Machine Grading, Special** pay item and plan quantities included in the proposal. No additional payment will be made for this work, which is shown on the plans and specified herein as work which needs to be completed, and may not be described as included in the pay item. Plan quantities will be paid for the work, and will only be adjusted due to changes in the limits of the work, as directed by the Engineer, in writing.

The pay item **Machine Grading, Special** shall include all the work specified herein, including, but not limited to, the removal and offsite disposal of any surplus or unsuitable materials and the furnishing from off-site any additional Engineer approved fill materials necessary to construct the embankment and subgrade to the contours and cross-sections shown on the plans.

The Contractor is advised that due to the nature of this project and the probable unsuitability of some or all of the excavated material for use as approved fill material, there may be imbalances

between the amount of earth excavation which is suitable for reuse as embankment, and the amount of embankment needed for the construction activities shown on the plans, or as directed by the Engineer. The Contractor shall make provisions for such imbalances and shall include in the bid price for this work the cost of importing/furnishing, placement, and compaction of the material, as well as the cost of stockpiling and re-handling of imported and/or on-site Engineer approved materials as necessary to complete the work of constructing the embankment and subgrade to the cross sections shown on the plans.

CITY OF ANN ARBOR
 DETIALED SPECIFICATION
 FOR
DRAINAGE AND UTILITY STRUCTURES

AA:DAD

1 of 1

03/15/16

a. Description. This work consists of adjusting, cleaning, pointing, reconstructing, and temporary lowering drainage and utility (storm, sanitary, and water) structures as required whether shown or not shown on the plans, and as herein provided.

b. Materials. Provide materials in accordance with section 403 of the Michigan Department of Transportation (MDOT) 2012 Standard Specifications for Construction, unless otherwise directed by the Engineer.

c. Construction. Adjust, clean, point, reconstruct, and temporary lower drainage and utility structures in accordance with section 403 of the MDOT 2012 Standard Specifications for Construction, and as directed by the Engineer.

Reconstruct drainage and utility structures from the base using precast reinforced concrete units or concrete block masonry.

Point structures by removing loose and damaged mortar, filling joints between concrete and masonry units with new mortar, and striking joints so the exposed surface is smooth and free of voids.

d. Measurement and Payment. The completed work, as described, will be measured and paid for at the contract unit prices for the following pay items:

<u>Pay Item</u>	<u>Pay Unit</u>
Dr Structure, Adj, Add Depth, Modified	Foot
Dr Structure, Adj, Case 1, Modified	Each
Dr Structure, Adj, Case 2, Modified	Each
Dr Structure, Cleaning, Modified.....	Each
Dr Structure, Point.....	Each
Dr Structure, Reconstruct	Each
Dr Structure, Temp Lowering, Modified	Each

These items will be measured in place by their respective unit and paid for at their respective contract unit price, which price shall be payment in full for all labor, materials and equipment needed to accomplish this work.

CITY OF ANN ARBOR
 DETAILED SPECIFICATION
 FOR
STRUCTURE COVERS

AA:DAD

1 of 2

03/15/16

a. Description. This work shall consist of replacing and furnishing frames and covers for utility (storm, sanitary, and water) structures as shown on the Plans and as directed by the Engineer, in accordance with section 403 of the edition of the Michigan Department of Transportation (MDOT) 2012 Standard Specifications for Construction, except as specified herein.

b. Materials. Materials shall meet the requirements of sections 403 and 908 of the MDOT 2012 Standard Specifications. All frames and covers shall conform to the model(s) shown in the table below.

Type of Casting	Associated Pay Item (MDOT Designation)	EJ No.	NEENAH No.
Manhole Frame and Cover	Dr Structure Cover, Special	1040AGS	
Manhole Frame and Cover	Dr Structure Cover, Type B, Modified (Type B)	1040 w/ Type A Cover Type M1	R-1642 w/ Type C Cover Type D Cover
Flat Inlet Frame and Cover	Dr Structure Cover, Type D, Modified (Type D)	5000 w/ Type M2 Sinusoidal Grate	
Curb Inlet/Catch Basin Frame and Cover	Dr Structure Cover, Type K, Modified (Type K)	7045Z w/ 7045M1 Sinusoidal Grate	R-3249F

All storm covers shall have the lettering "DUMP NO WASTE!" and a fish image. All sanitary and water covers shall have "SEWER" and "W" respectively cast on the surface.

Frames and covers shall have machined bearing surfaces. Covers shall have two (2), 1-inch vent holes located opposite each other and 6-inches from the edge.

Frames and covers for monument and gate (water-valve) boxes will be provided by the City of Ann Arbor. The Contractor shall transport these to the site from the City's W.R. Wheeler Service Center located at 4251 Stone School Road.

c. Construction. Materials shall be stored by the Contractor at locations arranged by the Contractor, subject to the approval of the Engineer. The Contractor shall not store materials or equipment, including metal castings and steel plates, on any lawn area.

The Contractor shall deliver all salvaged covers and castings to the W.R. Wheeler Service Center within two days of their removal.

d. Measurement and Payment. The completed work, as described, will be measured and paid for at the contract unit prices for the following pay items:

<u>Pay Item</u>	<u>Pay Unit</u>
Dr Structure Cover, Special	Each
Dr Structure Cover, Type B, Modified.....	Each
Dr Structure Cover, Type D, Modified.....	Each
Dr Structure Cover, Type K, Modified.....	Each

The unit prices for these items of work shall include all labor, material, and equipment costs to perform all the work specified in the MDOT 2012 Standard Specifications and as modified by this Detailed Specification.

Payment for transporting new and salvaged frames and covers to and from the W.R. Wheeler Center is included in other items of work.

CITY OF ANN ARBOR
DETAILED SPECIFICATION
FOR
DRAINAGE STRUCTURE, DOUBLE INLET

AA:DAD

1 of 1

03/15/16

a. Description. This work consists of constructing double inlet drainage structures as shown on the plans, and as herein provided.

b. Materials. Provide materials in accordance with section 403 of the Michigan Department of Transportation (MDOT) 2012 Standard Specifications for Construction, unless otherwise directed by the Engineer.

c. Construction. Construct double inlet drainage structures in accordance with section 403 of the MDOT 2012 Standard Specifications for Construction, the attached City of Ann Arbor Standard Detail SD-S-11, and as directed by the Engineer.

d. Measurement and Payment. The completed work, as described, will be measured and paid for at the contract unit price for the following pay item:

<u>Pay Item</u>	<u>Pay Unit</u>
Dr Structure, Double Inlet	Each

Dr Structure, Double Inlet will be measured in place respectively by the unit each and paid for respectively at the contract unit price per each, which price shall be payment in full for all labor, materials and equipment needed to accomplish this work.

CITY OF ANN ARBOR
DETAILED SPECIFICATION
FOR
HMA PAVING

AA:DAD

1 of 3

03/15/16

a. Description. Hot Mix Asphalt (HMA) pavement base, leveling, and top courses shall be constructed in accordance with section 501 of the Michigan Department of Transportation (MDOT) 2012 Standard Specifications for Construction, except as modified herein, and as directed by the Engineer.

b. Materials. None specified.

c. Construction.

1. Equipment: All equipment shall conform to subsection 501.03.A of the MDOT 2012 Standard Specifications for Construction, except as modified herein.

The Contractor shall have a 10 foot long straight edge, rubber-tired backhoe (Case 580 type, or equivalent), air-compressor with the ability to develop a minimum pressure of 100 pounds per square inch and continuous rated capacity of 150 cubic feet per minute of air flow, and jackhammer available during all paving operations. The Contractor shall be required to perform any miscellaneous cleaning, trimming, material removal, and other tasks as required by the Engineer in order to ensure the proper and orderly placement of all HMA materials on this project.

The Contractor shall provide sufficient rollers to achieve the specified asphalt densities.

At various times throughout the work, the Engineer may direct the Contractor to use smaller and/or lighter equipment, and to defer certain work tasks, in order to protect the grade and/or adjacent areas; including hauling units. The Contractor shall not be entitled to any additional compensation for the use of smaller equipment, lighter equipment, or work task deferral.

2. Cleaning and Bond Coat Application: Cleaning and bond coat application shall be performed in accordance with subsections 501.03.C and 501.03.D of the MDOT 2012 Standard Specifications for Construction, except as modified herein, and as directed by the Engineer.

The Contractor shall furnish and operate throughout the construction period, vacuum-type street cleaning and utility structure cleaning equipment (Vac-All, Vector, etc.) approved by the Engineer, and when directed by the Engineer, for street cleaning immediately prior to, and for street and utility structure cleaning after any and all paving. The cleaning equipment shall be of sufficient power to remove dust, dirt, and debris from the pavement and from utility structures in and adjacent to the construction area. The vac-all or similar equipment and shall be approved by the Engineer prior to beginning the work. The equipment used shall have an effective means for preventing any dust resulting from the operation from escaping into the air.

The bond coat shall be applied at a rate of 0.10 gallons per square yard. Before placing the bond coat, the existing pavement surface shall be thoroughly cleaned. The Contractor shall also thoroughly clean all joints, cracks, and edges to a minimum depth of one inch with compressed air, vac-all type equipment, or other approved mechanical or hand methods, to remove all dirt, debris, and all foreign material.

3. HMA Placement: Placement shall conform to subsection 501.03.F of the MDOT 2012 Standard Specifications for Construction, except as modified herein, and as directed by the Engineer.

HMA placement shall not commence until a "Permit to Place" (no additional costs are required to obtain this permit) has been issued in writing by the Engineer. The Permit to Place shall be issued after the aggregate base course or the adjacent, underlying layer of pavement section has been approved by the Engineer.

The final structure adjustments must be approved by the Engineer prior to the issuance of the "Permit to Place" for the top course.

The top course shall be placed with a ¼" lip at the gutter edge of metal.

All HMA thickness dimensions are compacted-in-place.

4. Paving Operation Scheduling: The Contractor shall schedule the paving operation to avoid longitudinal cold joints that would be required to be left "open" over night.

In all cases, the Contractor shall pave the primary road's through-traffic lanes ("main line") first, from point-of-beginning to the point-of-ending. All other paving including, but not limited to; acceleration and deceleration lanes, intersection approaches, and center left-turn lanes shall be paved following completion of main line paving, unless authorized by the Engineer prior to the placement of any pavement.

5. Rate of Paver Operation: The rate of the paver's travel shall be maintained such that the paving operation will be continuous; resulting in no transverse cold joints, but shall never exceed the rate of 50 feet per minute.

The Contractor shall furnish and operate enough material, equipment, and hauling units so as to keep the paving machine(s) moving continuously at all times. Failure to do so shall be cause for the suspension of the paving operation until the Contractor can demonstrate to the satisfaction of the Engineer, that sufficient resources have been dedicated to perform the work in accordance with the project specifications.

6. Longitudinal and Transverse Joints: These joints shall conform to subsection 502.03.F of the MDOT 2012 Standard Specifications for Construction, and as specified herein.

For mainline HMA paving, the width of the mat for each pass of the paver shall be not less than 10.5 feet, or greater than 15 feet, except as noted in the plans and as directed by the Engineer. The Engineer will direct the layout of all HMA longitudinal joints during construction.

7. Feather Joints – shall be constructed so as to vary the thickness of the HMA from zero inches to the required paving thickness at the rate of approximately 1.5” over a distance of 10 feet, or as directed by the Engineer. The Contractor shall rake the larger pieces of aggregate out of feather joints prior to compaction.

8. Butt Joints: Construction of butt joints, where directed by the Engineer, shall conform to subsections 501.03.C.3 and 501.03.C.4 of the MDOT 2012 Standard Specifications for Construction, except as modified herein.

When a butt joint is specified or directed to be placed by the Engineer, remove the existing HMA surface to the thickness of the proposed overlay, or full-depth, as directed by the Engineer, for the full width or length of the joint. The HMA material shall be sawcut to the directed depth along the pavement edge or removal line to prevent tearing of the pavement surface. Cut joints that will be exposed in the completed surface must be cut with a saw or a cold-milling machine or other methods approved by the Engineer. Joints that will be covered by HMA must be cut with a saw, a cold-milling machine, or other methods approved by the Engineer.

9. Rakers: The Contractor shall provide a minimum of two asphalt rakers during the placement of all wearing and leveling courses.

10. Faulty Mixtures: The Contractor and Engineer shall carefully observe the paving operation for signs of faulty mixtures. Points of weakness in the surface shall be removed or corrected by the Contractor, at his/her sole expense, prior to paving subsequent lifts of bituminous material. Such corrective action may include the removal and replacement of thin or contaminated sections of pavement, segregated HMA, and any sections that are weak or unstable. Once the Contractor or his representative is notified by the Engineer that the material being placed is out of allowable tolerances, or that there is a problem with the paving operation, the Contractor shall stop the paving operation at once, and shall not be permitted to continue placing bituminous material until again authorized by the Engineer. Any costs associated with meeting the requirements specified herein shall not be paid for separately, but shall be included in the item(s) of work being performed at the time the faulty mixture was discovered.

d. Measurement and Payment. Unused HMA remaining in trucks after the work is completed shall be returned to the plant and re-weighed, and the corrected weight slip shall be provided to the Engineer. No payment will be made for the unused HMA material. All weight slips must include the type of mixture (codes are not acceptable), as well as vehicle number, gross weight, tare weight and net weight.

All costs of meeting the requirements of this special provision shall be included in the bid prices for HMA items in the proposal and will not be paid for separately.

CITY OF ANN ARBOR
DETAILED SPECIFICATION
FOR
HMA TRAFFIC CALMING MEASURES

AA:DAD

1 of 1

03/15/16

a. Description. This work consists of constructing traffic calming devices at locations directed by the Engineer, in accordance with the special details shown on the plans, and as described herein.

b. Materials. Provide materials in accordance with section 501 of the Michigan Department of Transportation (MDOT) 2012 Standard Specifications for Construction. Use MDOT mixture HMA, LVSP for this work, or an acceptable substitute approved by the Engineer.

c. Construction. Perform work in accordance with section 501 of the MDOT 2012 Standard Specifications for Construction, and as directed by the Engineer.

Provide a 10-foot long straight-edge and a 10-foot long level during all paving operations.

Clean the existing surface with compressed air and/or vacuum type street cleaning equipment to remove dirt and debris prior to placement of HMA material. Provide compressed air from a source capable of supplying air at a minimum pressure of 90 psi and at a rate 150 cubic feet per minute of at the nozzle.

Apply MDOT SS-1h bond coat on all asphalt and concrete surfaces within the area where the traffic calming measure is to be installed. Apply at a rate of 0.10 gallons/square yard using a power distributor hand sprayer.

Placing traffic calming measure using an asphalt paving machine or, where approved by the Engineer, place HMA material directly by hand. Do not place HMA materials on adjacent pavement surfaces.

Construct traffic calming measures two (2) lifts/layers. Compact each lift of HMA mixture to between 92 and 96 percent (or as determined acceptable by the Engineer) of the theoretical maximum density, as listed on the approved Job Mix Formula. Place permanent thermoplastic pavement markings in accordance with the special detail on the project plans. Permanent thermoplastic pavement markings will be paid separately.

d. Measurement and Payment. The completed work, as described, will be measured and paid for at the contract unit prices for the following pay items:

<u>Pay Item</u>	<u>Pay Unit</u>
HMA, Raised Crosswalk	Square Yard
HMA, Raised Intersection	Square Yard
HMA, Speed Hump	Square Yard

The unit prices for these items of work shall include all labor, material, and equipment costs to perform all work specified in this Detailed Specification.

CITY OF ANN ARBOR
 DETIALED SPECIFICATION
 FOR
HMA, WEDGING, 36A

AA:DAD

1 of 1

03/15/16

a. Description. This work consists of constructing hot mix asphalt (HMA) finish wedges at drive approaches, sidewalk ramps, and any other location(s) directed by the Engineer, and as described herein.

b. Materials. Provide materials in accordance with section 501 of the Michigan Department of Transportation (MDOT) 2012 Standard Specifications for Construction. Use MDOT mixture HMA, 36A for this work, or an acceptable substitute approved by the Engineer.

c. Construction. Perform work in accordance with section 501 of the MDOT 2012 Standard Specifications for Construction, and as directed by the Engineer.

Complete all finish wedging within two days of placing the top course pavement.

Have a 10-foot long straight-edge, backhoe, air-compressor and jackhammer available during all paving operations.

Use finish wedges shall to provide good vertical and horizontal transitions between old and new construction, eliminate areas of standing water in the wearing surface, and allow for positive drainage.

Construct joints by feathering the edges of all finish wedges (including the raking out of all large pieces of aggregate) to provide a high quality, smooth riding surface.

Clean the existing surface with compressed air and/or vacuum type street cleaning equipment prior to placement of wedging material.

Apply MDOT SS-1h bond coat on all asphalt and concrete surfaces within the wedging area at a rate of 0.10 gallons/square yard using a power distributor hand sprayer.

d. Measurement and Payment. The completed work, as described, will be measured and paid for at the contract unit prices for the following pay items:

<u>Pay Item</u>	<u>Pay Unit</u>
HMA, Wedging, 36A	Ton

The unit price for this item of work includes all labor, material, and equipment costs to perform all the work specified in the Standard Specifications and as modified by this Detailed Specification.

Return all unused portions of material loads to the plant for re-weighing. Provide a corrected weight slip to the Engineer. Include type of mixture delivered to the site (codes are not acceptable), as well as vehicle number, gross weight, tare weight, and net weight on all weight slips.

CITY OF ANN ARBOR

DETAILED SPECIFICATION
FOR
REMOVING HOT MIX ASPHALT AROUND STRUCTURE COVERS

AA:DAD

1 of 1

03/15/16

a. Description. This work consists of removing hot mix asphalt (HMA) from around existing (not lowered) structure covers during the cold milling operations as required, whether structures are shown or not shown on the plans, and as herein provided. Covers include those used for storm, sanitary, and water structures, gate and monument boxes, and other private utility structures.

This item does not apply to locations (streets) where structures have been temporary lowered in advance of the cold milling operations.

b. Materials. None specified.

c. Construction. Remove HMA surface around structure covers to the same depth as the cold milled surface without the removal of the aggregate or concrete base. Complete work in accordance with sections 204 and 501 of the MDOT 2012 Standard Specifications for Construction, and as directed by the Engineer.

Remove HMA surface, any thickness, from around existing structure covers using a milling machine, and/or hand tools, or other means as approved by the Engineer. Repair or replacement of any structure covers damaged during this operation is the sole responsibility of the Contractor.

d. Measurement and Payment. The completed work, as described, will be measured and paid for at the contract unit prices for the following pay items:

<u>Pay Item</u>	<u>Pay Unit</u>
HMA Surface, Around Structure Cover, Rem.....	Each

The unit price for this item of work shall include all labor, material, and equipment costs to perform all the work specified in the Standard Specifications and as modified by this Detailed Specification.

The number of castings within the milling limits shall constitute the final amount. Measurement shall take place with both the Engineer and the Contractor (or their agents) present.

CITY OF ANN ARBOR
 DETAILED SPECIFICATION
 FOR
FLOWABLE FILL

AA:DAD

1 of 2

03/15/16

a. Description. This work consists of furnishing and placing flowable fill as backfill material at miscellaneous locations as shown on the plans, and as directed by the Engineer.

b. Materials. Provide flowable fill material, as directed by the Engineer, meeting one the following mixes:

1. Portland cement, fly ash, and water.
2. Portland cement, granular material, fly ash, and water.
3. Fly ash, granular material, and water.

Provide materials in accordance with the following requirements:

		⁽³⁾ <u>Specific Gravity</u>
Portland Cement	MDOT Section 901	3.15
Fly Ash	⁽¹⁾ ASTM C 618(I)	2.40
Granular Material, CI II	⁽²⁾ MDOT Section 902	2.60
Water	MDOT Section 911	1.00

Note: Reference to MDOT relates to applicable sections of the Michigan Department of Transportation 2012 Standard Specifications for Construction.

⁽¹⁾Except there is no limit on the loss of ignition.

⁽²⁾Except that 100% shall pass 3/4-inch sieve.

⁽³⁾Specific gravity values used for mix proportions given. If material used differs from these values make appropriate adjustments as required to achieve an acceptable mixture.

Acceptable mixtures for flowable fill are as follows:

1. FF Mix Number One
 Cement Stabilized Fly Ash Mixture (Class F Fly Ash)

Portland Cement	100 lbs/cyd
Fly Ash (Class F)	2000 lbs/cyd
Water	Sufficient amounts to produce the desired flowability (approx. 80 gal/cyd)

2. FF Mix Number Two
 Controlled Density Fill Mixture (Class F Fly Ash)

Portland Cement	50 lbs/cyd
Fly Ash (Class F)	500 lbs/cyd
Granular Material	2600 lbs/cyd
Water	Sufficient amounts to produce the desired flowability (approx. 50 gal/cyd)

CITY OF ANN ARBOR
DETAILED SPECIFICATION
FOR
FLOWABLE FILL

AA:DAD

2 of 2

03/15/16

- 3. FF Mix Number Three
Controlled Density Fill Mixture (Class C Fly Ash)

Fly Ash (Class C)	300 lbs/cyd
Granular Material	2600 lbs/cyd
Water	Sufficient amounts to produce the desired flowability (approx. 50 gal/cyd)

c. Construction. Furnish and place flowable fill at miscellaneous locations as shown on the plans, and as directed by the Engineer.

All flowable fill, after setting, is intended to be removable by conventional mechanical excavation methods.

d. Measurement and Payment. The completed work, as described, will be measured and paid for at the contract unit prices for the following pay items:

<u>Pay Item</u>	<u>Pay Unit</u>
Flowable Fill	Cubic Yard

The unit price for this item of work shall include all labor, material, and equipment costs to perform all the work specified by this Detailed Specification.

Flowable fill used at the Contractor's option will not be paid for separately, but shall be included either in the bid price(s) for the associated work item(s), or in the bid price for the item of work "General Conditions, Max \$___".

CITY OF ANN ARBOR
DETAILED SPECIFICATION
FOR
SIDEWALK RETAINING WALLS

AA:DAD

1 of 2

03/15/16

a. Description. This work consists of constructing concrete retaining walls adjacent to sidewalks in accordance with the applicable standards plan and special detail included in the Contract documents, as specified herein, and as directed by the Engineer.

b. Materials. Provide concrete Grade P-NC, unless otherwise directed by the Engineer, meeting the requirements of section 602 of the Michigan Department of Transportation (MDOT) 2012 Standard Specifications for Construction.

c. Construction. Construct "Sidewalk Retaining Wall, Integral, Less than 6 inch Height" in accordance with MDOT Standard Plan R-30 series for Detail E2 curb. Curb face exposure shall be 6 inches or less.

Construct "Sidewalk Retaining Wall, Integral, 6 inch to 18 inch Height" as shown on the special detail.

All subgrade work shall be completed prior to placing concrete items, unless directed or approved by the Engineer.

The Contractor shall excavate, cut, remove stumps, remove brush, remove pavement, grade, and trim as needed and as directed, and shall import, furnish, fill, place, grade, and compact any materials needed to perform the work.

At locations where the subgrade, subbase or base becomes either disturbed, saturated or otherwise damaged, and where directed by the Engineer, the Contractor shall remove a minimum 6-inch thick layer of the subgrade, subbase or base, and replace it with approved 21AA Aggregate material, compacted in place.

The Contractor shall coordinate with the City Forester prior to the removal of any tree roots 2 inches in diameter or greater.

The Contractor shall maintain on-site at all times, a sufficient quantity of adequate materials to protect concrete items. The Engineer may suspend or defer concrete placement if rain protection is not available. The Contractor shall not be entitled to any additional compensation due to work suspension or deferral resulting from a lack of adequate rain protection.

The Contractor is responsible for any damage to concrete items, including but not limited to vandalism; vehicular, pedestrian and/or miscellaneous structural damage; surface texture damage; and rain damage.

d. Measurement and Payment. The completed work, as described, will be measured and paid for at the contract unit prices for the following pay items:

<u>Pay Item</u>	<u>Pay Unit</u>
Sidewalk Retaining Wall, Integral, Less than 6 inch Height.....	Square Foot
Sidewalk Retaining Wall, Integral, 6 inch to 18 inch Height.....	Square Foot

The unit prices for these items of work shall include all labor, material, and equipment costs to perform all the work specified by this Detailed Specification. Quantity shall be measured by the exposed face area of the retaining wall in square feet. The sidewalk section will be paid for separately.

CITY OF ANN ARBOR
DETAILED SPECIFICATION
FOR
REMOVAL AND REINSTALLATION OF CONCRETE OR CLAY BRICK PAVERS

AA:DAD

1 of 2

03/15/16

a. Description. This work consists of removing, stockpiling and reinstalling sidewalk pavers, furnishing and installing sand base, concrete base, fine aggregate leveling bed, fine aggregate joint filler, and any additional brick pavers as shown on the plans, and as directed by the Engineer.

b. Materials.

Aggregate base, where required, shall consist of Dense-Graded Class 21AA Limestone in accordance with section 902 of the Michigan Department of Transportation 2012 Standard Specifications for Construction.

Sand base, where required, shall consist of Granular Material Class II in accordance with section 902 of the MDOT 2012 Standard Specifications for Construction.

Concrete base, where required, shall be constructed of Grade P1 or Grade P2 concrete in accordance with section 601 of the MDOT 2012 Standard Specifications for Construction.

Fine aggregate leveling bed shall consist of a 3:1 mix of Fine Aggregate 2NS (3 parts) and Type N Masonry Cement (1 part). Fine Aggregate 2MS shall be used as joint filler. Masonry cement and fine aggregate materials shall be in accordance with sections 901 and 902, respectively, of the MDOT 2012 Standard Specifications for Construction.

Any additional brick pavers required shall match the existing brick in the areas adjoining the removal/replacement limits.

c. Construction. The Contractor shall remove and salvage existing pavers, remove any existing mortar or bituminous setting bed and concrete base, to the limits specified by the Engineer, down to the existing aggregate base. Where an existing base is not present, the subbase shall be removed to a sufficient depth for construction of the proposed section as shown on the attached detail, or as directed by the Engineer. Salvaged pavers shall be stored on-site in an area approved by the Engineer until they are ready to be replaced.

The Contractor shall shape, grade, and compact the existing base materials, and shall construct the base to match the existing adjacent elevations.

Fine aggregate and mortar shall be uniformly blended to create the leveling bed mix. Leveling bed is to be placed on aggregate base or existing concrete base to the depth shown on the Plans. Control bars and/or guides shall be used to screed the fine aggregate leveling bed.

Brick installation is to match the pattern of the existing adjacent brickwork. String lines or other devices are to be used as needed to insure straight joint lines and final surface elevations. Paving units are to be butted tight to adjacent concrete paving and to each other. Newly laid pavers are to be protected at all times by plywood panels on which workers stand. A minimum of three (3) passes of a plate vibrator (min. 5,000 lbs compaction force) shall be made to set paving units in leveling course prior to filling joints. Pavers should be protected from chipping and cracking during compaction.

Fine aggregate joint filler shall be spread over paver surface and broomed into joints, and misted

lightly with water to settle sand into joints. Allow to surface dry and repeat process until joints are filled completely. Remove excess sand upon completion.

The Contractor shall take any necessary precautions to prevent damage to pavers during removal and replacement. The Contractor is not entitled to any additional compensation for such replacement of damaged pavers.

d. Measurement and Payment. The completed work, as described, will be measured and paid for at the contract unit prices for the following pay items:

<u>Pay Item</u>	<u>Pay Unit</u>
Sidewalk, Conc or Clay Brick Pavers, Rem and Reinstall.....	Square Foot

The unit price for this item of work shall include all labor, material, and equipment costs to perform all the work specified by this Detailed Specification.

CITY OF ANN ARBOR
 DETAILED SPECIFICATION
 FOR
PAVEMENT MARKINGS

AA:DAD

1 of 1

03/15/16

a. Description. This work consists of providing and placing permanent pavement markings in accordance with the Michigan Manual on Uniform Traffic Control Devices (MMUTCD). Provide pavement markings that conform to the plans, the Michigan Department of Transportation (MDOT) 2012 Standard Specifications for Construction, MDOT Pavement Marking Standard Plans, City of Ann Arbor Special Details, and as specified herein.

b. Materials. Provide materials in accordance with sections 811 and 920 of the MDOT 2012 Standard Specifications for Construction. Provide the Material Safety Data Sheets to the Engineer for required materials and supplies. Dispose of unused material and containers in accordance with the Federal Resource Conservation Recovery Act (RCRA) of 1976 as amended, and 1994 PA 451, Part 111 Hazardous Waste Management. Provide samples of permanent pavement marking materials upon request.

c. Construction Methods. The preparation and placement of permanent pavement markings shall conform to section 811 of the MDOT 2012 Standard Specifications, the plans, and as specified herein.

d. Measurement and Payment. The completed work, as described, will be measured and paid for at the contract unit prices for the following pay items:

<u>Pay Item</u>	<u>Pay Unit</u>
Pavt Mrkg, Thermopl, 24 inch, Crosswalk	Foot
Pavt Mrkg, Thermopl, Lt Turn Arrow Sym	Each
Pavt Mrkg, Thermopl, Only	Each
Pavt Mrkg, Thermopl, Railroad Sym	Each
Pavt Mrkg, Thermopl, Rt Turn Arrow Sym	Each
Pavt Mrkg, Thermopl, School	Each
Pavt Mrkg, Thermopl, Speed Hump Chevron, White	Each

The unit price for these items of work shall include all labor, material, and equipment costs to perform all the work specified in the MDOT 2012 Standard Specifications and as modified by this Detailed Specification.

CITY OF ANN ARBOR
DETAILED SPECIFICATION
FOR
MAINTENANCE OF TRAFFIC

AA:DAD

1 of 5

03/15/16

a. Description. Traffic shall be maintained by the Contractor at the locations identified on the "Schedule of Streets" for duration of the work in accordance with the plans, subsection 104.11 and section 812 of the Michigan Department of Transportation (MDOT) 2012 Standard Specifications for Construction, the Michigan Manual of Uniform Traffic Control Devices (MMUTCD), applicable supplemental specifications, as directed by the Engineer, and as herein specified.

The following, and herein included, Michigan Department of Transportation (MDOT) Maintaining Traffic Typical and Work Zone Device Details apply to the project: M0020a, M0040a, M0110a, M0140a, M0240a WZD-100-A, and WZD-125-E.

These maintaining traffic provisions are subject to change in the event of special community activities.

The permanent pavement marking items are included in the contract and shall be placed per the MDOT 2012 Standard Specifications for Construction prior to the removal of any devices required to temporarily maintain traffic during construction, and also prior to opening the project to traffic.

b. Materials. Materials for all devices used to temporarily control and maintain traffic shall meet the requirements of section 812 of the MDOT 2012 Standard Specifications for Construction, the MMUTCD, and the applicable MDOT typicals and details included herein.

All signs shall be of sizes shown on the plans, unless otherwise directed by the Engineer. Temporary signs, which are to remain in the same place for 14 days or more, shall be installed on driven posts. All other temporary signs may be installed on portable supports. All signs shall have a minimum bottom height of 7.0 feet.

Channelizing devices required for all lane closures shall be plastic drums. 42 inch channelizing devices are permissible at certain locations with approval from the Engineer.

c. Construction. Construction methods shall meet the requirements of section 812 of the MDOT 2012 Standard Specifications for Construction.

The Contractor shall furnish and place all necessary temporary traffic control devices to maintain traffic during construction. All work, construction equipment, and material storage shall be kept behind the curb, or behind barricades or channelizing devices, all in combination with protective fencing, if required to protect open excavations, and shall not in any way hamper vehicle movement or impair traffic vision. The contractor shall also provide protection to all uncured concrete sidewalk, driveways, and curb and gutter as may be needed until all traffic, either foot or otherwise, can cross without damage. Additional barricades and protective fencing shall be installed at the end of each day to insure no disturbance to the work area.

Distances between warning, regulatory, and guide signs as shown on the typicals and details are approximate, and may require field adjustment, as directed by the Engineer.

The Contractor shall maintain two-way traffic as shown on the plans, access for local traffic on local streets, and keep all intersections open to traffic at all times, unless specifically authorized in writing by the Engineer.

The Contractor shall maintain traffic such that no vehicle shall be required to drive into active work areas. Patch areas which extend more than halfway across the roadway shall be removed and replaced so as to provide a minimum of half the pavement width at all times for maintaining traffic.

The Contractor shall remove existing pavement markings and place temporary pavement markings as directed by the Engineer.

All temporary traffic/pedestrian control devices furnished by the Contractor shall remain the property of the Contractor. The City shall not be responsible for stolen or damaged signs, barricades, plastic drums and other traffic maintenance items. The Contractor shall replace missing and/or damaged traffic control devices immediately, at no additional cost to the City.

1. Construction Influence Area (CIA). The CIA shall consist of, at each location, the width of the right-of-way and easements, and the limits of any advance temporary construction signing shown on the plans and applicable maintaining traffic typicals along the street under construction and any/all cross streets. Posted detour routes are not considered part of the CIA.

The Contractor shall furnish, erect, maintain, and upon completion of the work, remove all traffic control devices within and around the CIA, and along posted detour routes, for the safety and protection of traffic. This includes, but is not limited to, regulatory and warning signs, barricades, channeling devices and other minor devices where required by the Engineer.

The Contractor shall coordinate its operations with all subcontractors, utilities, and/or other contractors performing work on this and other projects within, or adjacent to, the Construction Influence Area (CIA). The contractor shall avoid conflicts in maintaining traffic operations, signing, and orderly progress of other contract work.

2. Permits. Prior to the start of construction, the Contractor shall obtain a "Right-of-Way" Permit from City of Ann Arbor Customer Services Unit. The Contractor shall notify the Project Engineer and obtain a "Traffic Detour or Lane Closure" Permit from City of Ann Arbor Project Management Services Unit a minimum of 72 business hours prior to the implementation of any traffic shifts, lane closures and street closures. The fees for these permits will be waived.

3. Work Times and Restrictions. All work shall be conducted Monday through Saturday between 7:00am and 8:00pm; unless an alternate plan identifying the days and hours of work has been authorized by the City prior to commencement of construction. Should night work be required for any reason, the Project Engineer must be notified three (3) working days (72 hours) in advance of such work, and the work must have the approval of the City prior to commencement.

Only work of an emergency nature or work required to insure traffic safety shall be performed on Sunday and only with prior approval by the City.

No road work shall be performed nor traffic interruptions be permitted, including lane closures, on Sundays, and during the Memorial Day, July 4th, and Labor Day holiday periods unless otherwise authorized by the Engineer. All streets and sidewalks that can be opened shall be opened. Trucking on or off site will not be permitted.

During non-working periods, any area with uncompleted work shall have plastic drums at specific locations and protective fencing, as directed by the Engineer, and at no additional cost to the project.

4. Traffic Restrictions. The Contractor shall, at all times, conduct its work to insure the least possible obstruction to traffic and inconvenience to the general public, businesses, and residents in the vicinity of the work.

Traffic on major streets should not be impacted between the hours of 7:00 a.m. to 9:00 a.m. and from 3:30 p.m. to 6:00 p.m. unless otherwise approved by the Engineer or as specified on the Lane Closure Permit. All major changes in traffic control shall be made either between 9:00 a.m. and 3:30 p.m. or between 7:00 p.m. and 6:30 a.m. in order to minimize interference with rush hour traffic. All traffic controls must be in place and ready for traffic each day by 6:30 a.m. and 3:30 p.m. Temporary obstruction of traffic for loading and unloading of trucks will be permitted if the Contractor provides traffic regulators (flag persons) in conformance with Part VI of the MMUTCD. During temporary obstructions, a minimum of two traffic regulators are required. The cost of traffic regulators (flag control) shall be included in the contract pay item "Minor Traffic Control, Modified, Max \$_____".

Access to businesses, residences, and side street(s) within the CIA shall be maintained for the duration of the project. The Contractor shall make every effort to coordinate its operations to minimize interruptions impacting this access. The Contractor shall notify the Project Engineer forty-eight (48) hours in advance of any work to be performed on or near business or residential driveways, and stage work so that it is part-width when it is necessary to work in these areas. Prohibiting access to businesses and residences will not be allowed during any phase of construction, and flagging will be required at the discretion of the Engineer.

A minimum of one lane of traffic in each direction must be maintained on Pauline Blvd at all times by use of signage and other traffic control devices unless other authorized by the Engineer.

Lane width shall be a minimum of 9 feet wide. Contractor shall schedule work so that under no circumstances traffic is stopped. The work within the CIA shall be suspended, during peak traffic hours and/or when traffic is being unduly hampered or delayed by all construction activity, at the discretion of the Engineer.

5. Emergency Services. The Contractor shall notify local police, fire departments and emergency response units a minimum of three business days (72 hours) prior to the closure of any lanes, or traffic shifts causing restricted movements of traffic or restricted access. Fire hydrants in or adjacent to the work shall be kept "live" and fire fighting forces made aware of their availability at all times during construction.

d. Measurement and Payment. The completed work for maintaining traffic, as described, will be paid for at the contract unit prices for the following items in accordance with subsection 812.04 of the Standard Specifications for Construction.

<u>Pay Item</u>	<u>Pay Unit</u>
Barricade, Type III, High Intensity, Double Sided, Lighted, Furn.....	Each
Barricade, Type III, High Intensity, Double Sided, Lighted, Oper	Each
Channelizing Device, 42 inch, Furn	Each
Channelizing Device, 42 inch, Oper.....	Each
Pavt Mrkg, Longit, 6 inch or Less Width, Rem	Foot
Pavt Mrkg, Type NR, Paint, 4 inch, White, Temp.....	Foot
Pavt Mrkg, Type NR, Paint, 4 inch, Yellow, Temp	Foot
Pavt Mrkg, Type R, 4 inch, White, Temp	Foot
Pavt Mrkg, Type R, 4 inch, Yellow, Temp	Foot
Lighted Arrow, Type C, Furn.....	Each
Lighted Arrow, Type C, Oper	Each
Plastic Drum, High Intensity, Lighted, Furn.....	Each
Plastic Drum, High Intensity, Lighted, Oper	Each
Sign, Portable, Changeable Message, Furn	Each
Sign, Portable, Changeable Message, Oper.....	Each
Sign, Type B, Temp, Prismatic, Furn	Square Foot
Sign, Type B, Temp, Prismatic, Oper	Square Foot
Traf Regulator Control.....	Lump Sum
Minor Traffic Control, Modified, Max \$_____	Lump Sum

The estimated quantities for maintaining traffic are based on the signing and related traffic control devices deemed necessary for this project as shown on the plans and applicable MDOT Maintaining Traffic Typical, and include traffic regulators, lighted arrows and minor traffic devices.

Payment for furnishing and operating Type III Barricades and 42 inch Channelizing Devices shall be for the maximum quantity in use at any one time during the work for the entire project (all streets).

Measurement and payment for furnishing Lighted Arrows and Portable Changeable Message Signs will be based on the maximum number of units required for the entire project at any one time. Measurement and payment for operating Lighted Arrows and Portable Changeable Message Signs will be based on the maximum number of units in operation at any one time and will be paid after the initial placement into service and for each relocation to another street that follows.

Payment for furnishing and operating Plastic Drums and Temporary Type B Signs shall be for the maximum quantity in use on each street at any one time.

No Parking Signs will be measured as the maximum number installed on each street at any one time. The unit price includes the removal and return of No Parking signs to the City upon completion of the project. The Contractor shall be charged for the replacement cost for each damaged or unreturned sign.

Any additional signing or maintaining traffic devices required to expedite the construction shall be at the Contractor's expense unless approved by the Engineer.

Temporary traffic control devices will be paid for only once irrespective of the number of times moved. Traffic control devices not paid for separately shall be included in the payment for the pay item "Minor Traffic Control, Modified, Max \$____".

KEY

- • • CHANNELIZING DEVICES
- ⚡ LIGHTED ARROW PANEL
- ➡ TRAFFIC FLOW
- REFLECTS EXISTING SPEED LIMIT

SIGN = 136 ft±2 - TYPE B PLUS ADDITIONAL R2-1's THROUGHOUT WORK AREA

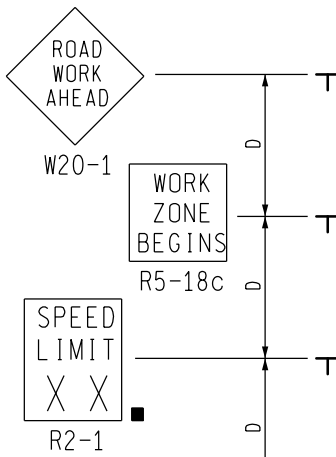

PLACE THIS SIGN ALONG WITH THE ADVANCE WORK ZONE SIGNING AS DEPICTED ON THE APPROPRIATE TYPICAL M0030a-M0080a.



PLACE THROUGHOUT WORK AREA AS INDICATED AND AFTER ALL MAJOR CROSSROADS IF PERMANENT SIGNS ARE NOT IN PLACE.



PLACE THROUGHOUT WORK AREA AS INDICATED AND AFTER ALL CROSSROADS IF PERMANENT SIGNS ARE NOT IN PLACE.

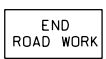

PLACE THIS SIGN ALONG WITH THE ADVANCE WORK ZONE SIGNING AS DEPICTED ON THE APPROPRIATE TYPICAL M0030a-M0080a.

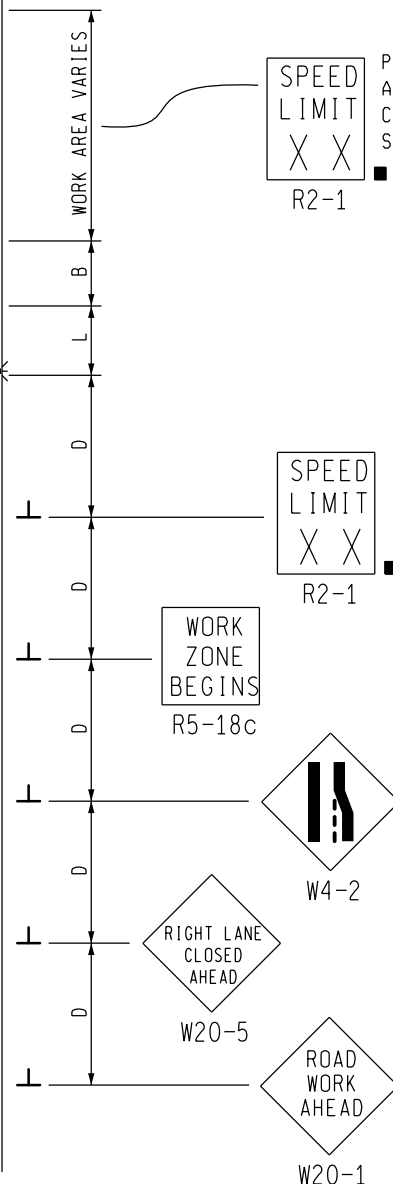
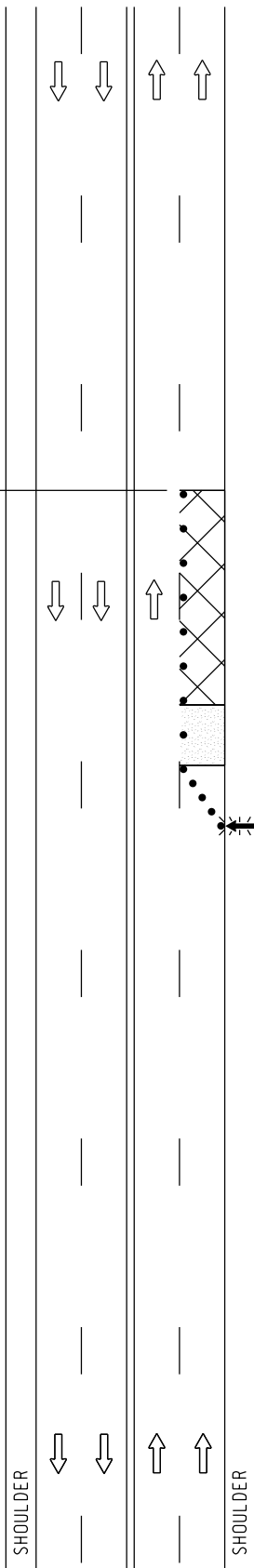

MDOT
Michigan Department of Transportation
TRAFFIC AND SAFETY
MAINTAINING TRAFFIC
TYPICAL

TYPICAL TEMPORARY TRAFFIC CONTROL
FOR A ONE-LANE CLOSURE ON AN
UNDIVIDED MULTI-LANE ROADWAY,
NO SPEED REDUCTION

DRAWN BY: CON:AE:djf
CHECKED BY: BMM:CRB

OCTOBER 2011
PLAN DATE:

M0240a

SHEET
1 OF 2

NOT TO SCALE

NOTES

- 1B. D = DISTANCE BETWEEN TRAFFIC CONTROL DEVICES
L = MINIMUM LENGTH OF TAPER
B = LENGTH OF LONGITUDINAL BUFFER
SEE M0020a FOR "D," "L," AND "B" VALUES
2. ALL NON-APPLICABLE SIGNING WITHIN THE CIA SHALL BE MODIFIED TO FIT CONDITIONS, COVERED OR REMOVED.
3. DISTANCES BETWEEN SIGNS, THE VALUES FOR WHICH ARE SHOWN IN TABLE D, ARE APPROXIMATE AND MAY NEED ADJUSTING AS DIRECTED BY THE ENGINEER.
- 3A. THE "WORK ZONE BEGINS" (R5-18c) SIGN SHALL BE USED ONLY IN THE INITIAL SIGNING SEQUENCE IN THE WORK ZONE. SUBSEQUENT SEQUENCES IN THE SAME WORK ZONE SHALL OMIT THIS SIGN AND THE QUANTITIES SHALL BE ADJUSTED APPROPRIATELY.
- 4E. THE MAXIMUM RECOMMENDED DISTANCE(S) BETWEEN CHANNELIZING DEVICES SHOULD BE EQUAL IN FEET TO THE POSTED SPEED IN MILES PER HOUR ON TAPER(S) AND TWICE THE POSTED SPEED IN THE PARALLEL AREA(S).
5. FOR OVERNIGHT CLOSURES, TYPE III BARRICADES SHALL BE LIGHTED.
6. WHEN CALLED FOR IN THE FHWA ACCEPTANCE LETTER FOR THE SIGN SYSTEM SELECTED, THE TYPE A WARNING FLASHER, SHOWN ON THE WARNING SIGNS, SHALL BE POSITIONED ON THE SIDE OF THE SIGN NEAREST THE ROADWAY.
7. ALL TEMPORARY SIGNS, TYPE III BARRICADES, THEIR SUPPORT SYSTEMS AND LIGHTING REQUIREMENTS SHALL MEET NCHRP 350 CRASHWORTHY REQUIREMENTS STIPULATED IN THE CURRENT EDITION OF THE MICHIGAN MANUAL ON UNIFORM TRAFFIC CONTROL DEVICES, THE CURRENT EDITION OF THE STANDARD SPECIFICATIONS FOR CONSTRUCTION, THE STANDARD PLANS AND APPLICABLE SPECIAL PROVISIONS. ONLY DESIGNS AND MATERIALS APPROVED BY MDOT WILL BE ALLOWED.
8. WHEN BUFFER AREAS ARE ESTABLISHED, THERE SHALL BE NO EQUIPMENT OR MATERIALS STORED OR WORK CONDUCTED IN THE BUFFER AREA.
21. ALL EXISTING PAVEMENT MARKINGS WHICH ARE IN CONFLICT WITH EITHER PROPOSED CHANGES IN TRAFFIC PATTERNS OR PROPOSED TEMPORARY TRAFFIC MARKINGS, SHALL BE REMOVED BEFORE ANY CHANGE IS MADE IN THE TRAFFIC PATTERN. EXCEPTION WILL BE MADE FOR DAYTIME-ONLY TRAFFIC PATTERNS THAT ARE ADEQUATELY DELINEATED BY OTHER TRAFFIC CONTROL DEVICES.
26. THE LIGHTED ARROW PANEL SHALL BE LOCATED AT THE BEGINNING OF THE TAPER AS SHOWN. WHEN PHYSICAL LIMITATIONS RESTRICT ITS PLACEMENT AS INDICATED, THEN IT SHALL BE PLACED AS CLOSE TO THE BEGINNING OF THE TAPER AS POSSIBLE.

SIGN SIZES

DIAMOND WARNING - 48" x 48"
R2-1 REGULATORY - 48" x 60"
R5-18c REGULATORY - 48" x 48"

NOT TO SCALE

 TRAFFIC AND SAFETY MAINTAINING TRAFFIC TYPICAL		TYPICAL TEMPORARY TRAFFIC CONTROL FOR A ONE-LANE CLOSURE ON AN UNDIVIDED MULTI-LANE ROADWAY, NO SPEED REDUCTION	
DRAWN BY: CON:AE:djf	OCTOBER 2011	M0240a	SHEET
CHECKED BY: BMM:CRB	PLAN DATE:		2 OF 2
FILES: PW-RD-TS/Typicals/Signs/MT NON FWY/M0240a.dgn REV. 10/11/2011			

ADD 3-52

CITY OF ANN ARBOR
DETAILED SPECIFICATION
FOR
MINOR TRAFFIC CONTROL

AA:DAD

1 of 4

03/15/16

a. Description. This work shall consist of protecting and maintaining vehicular and pedestrian traffic, in accordance with the City of Ann Arbor Standard Specifications for Construction sections 104.11 and 812 of the Michigan Department of Transportation (MDOT) 2012 Standard Specifications for Construction; Part 6 of the 2011 Edition of the Michigan Manual of Uniform Traffic Control Devices (MMUTCD); and, except as modified herein.

The work shall include, but is not limited to the following:

- The furnishing and operating of miscellaneous signs, warning devices, flags, and cones;
- The operation of additional signs furnished by the City;
- Furnishing and installing meter bags;
- Coordinating with the City to have meter heads removed and reinstalled;
- Maintaining pedestrian traffic;
- Temporarily covering traffic controls;
- Temporarily covering existing signs as directed;
- Any and all other miscellaneous and/or incidental items which are necessary to properly perform the work.

b. Materials. Materials and equipment shall meet the requirements specified in section 812 of the MDOT 2012 Standard Specifications for Construction.

c. Construction. The Contractor shall maintain pedestrian traffic at all times. For maintaining normal pedestrian traffic while performing sidewalk and driveway repair, Plastic Drum, High Intensity, Lighted shall be placed by the Contractor as directed by the Engineer. The Contractor, when directed by the Engineer, shall place "Sidewalk Closed" and/or "Cross Here" signs and the cost shall be included in this pay item and will not be paid for separately.

All temporary traffic/pedestrian control devices furnished by the Contractor shall remain the property of the Contractor. The City shall not be responsible for stolen or damaged signs, barricades, barricade lights or other traffic maintenance items. The Contractor shall replace missing traffic control devices immediately, at no additional cost to the Contractor or City. All existing signs, and signs erected by the City of Ann Arbor on this project shall be preserved, protected, and maintained by the Contractor. The City will repair any existing City owned signs, at the Contractor's expense, which are damaged by the Contractor during the work.

The Contractor shall temporarily cover conflicting traffic and/or parking signs when directed by the Engineer.

Parking violation citations issued to the Contractor, subcontractor, and material suppliers including each of their respective employees shall be enforced under appropriate City Code.

The work shall include: furnishing and operating of miscellaneous signs and warning devices; furnishing cones; operating additional signs furnished by the City throughout the life of the Contract; furnishing and operating pedestrian traffic control devices; maintaining a safe trench during all non-working hours; maintaining access to all drives; covering conflicting existing signs and removal of these covers; and any and all other miscellaneous and/or incidental items which are necessary to properly perform the work.

Where there is metered parking, the Contractor shall either rent and install meter bags, or, with the Engineer's authorization, coordinate with the City Field Operation Services to have meter heads removed and reinstalled.

The Contractor shall maintain vehicular and pedestrian traffic during the work by the use of traffic regulators, channelizing devices and signs as necessary, as directed by the Engineer, and in accordance with 2011 Edition of the MMUTCD. Typical applications for maintaining pedestrian traffic in accordance with the 2011 Edition of the MMUTCD are included in this detailed specification.

In order to maintain areas of on-street parking available for residents, the Engineer may direct the contractor to cover and uncover temporary "No Parking" signs within the project limits multiple times throughout the course of the project. Such repeated covering and uncovering of signs shall be included in this item of work and shall not be paid for separately.

d. Measurement and Payment. The completed work, as described, will be measured and paid for at the contract unit price for the following pay item:

<u>Pay Item</u>	<u>Pay Unit</u>
Minor Traffic Control, Max \$_____	Lump Sum

The unit price for this item of work shall include all labor, material, and equipment costs to perform all the work described by this Detailed Specification.

Costs for transporting barricades and other temporary traffic control devices shall be included in the bid prices for the individual items of work.

This item will be paid for on a pro rata basis with each progress payment. Measurement will be based on the ratio between work completed during the payment period and the total contract amount. When all of the work of this Contract has been completed, the measurement of this item shall be 1.0 Lump Sum minus any deductions incurred for inadequate performance as described herein. This amount will not be increased for any reason, including extensions of time, extras, and/or additional work.



Figure 6H-28. Sidewalk Detour or Diversion (TA-28)

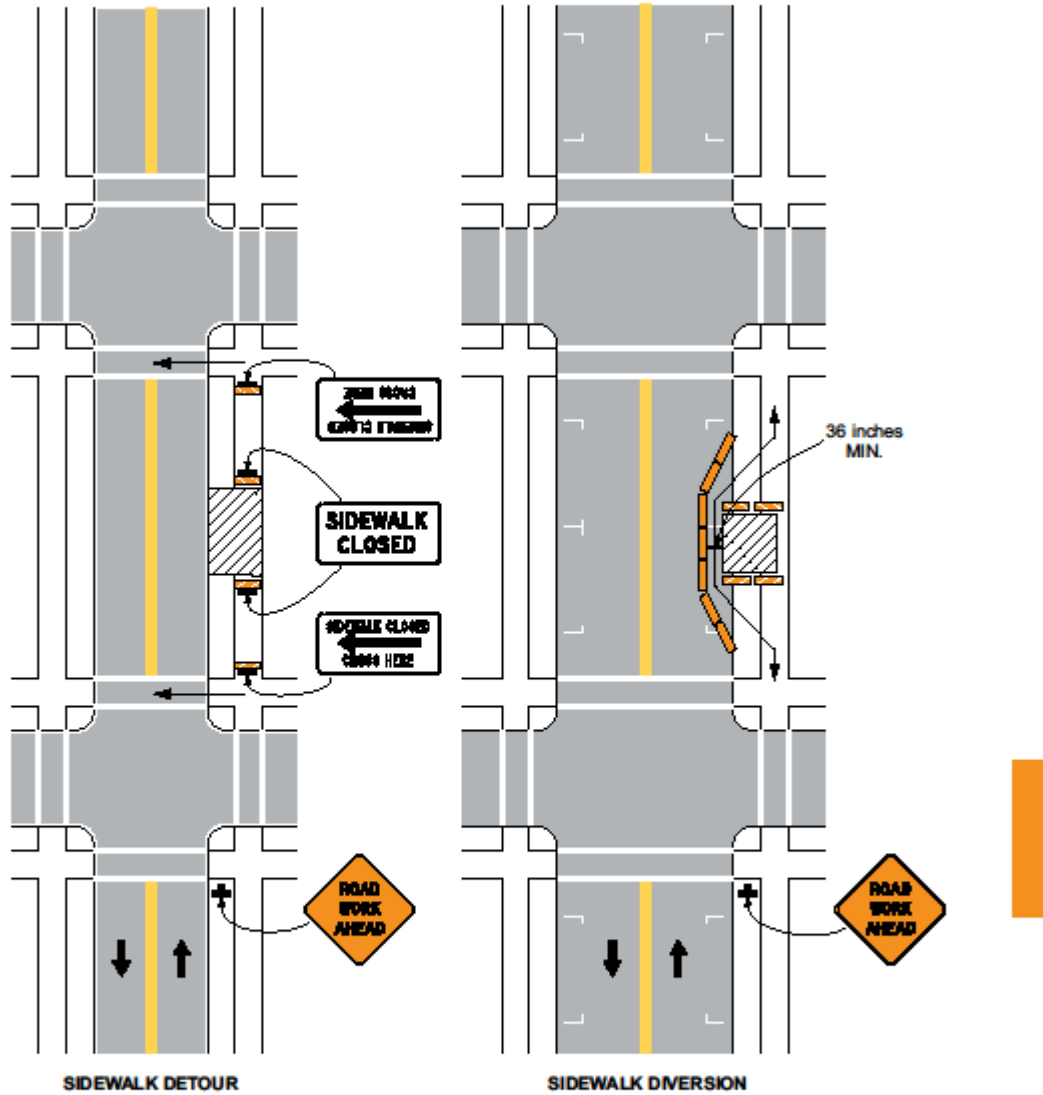

Typical Application 28

Note: See Tables 6H-2 and 6H-3 for the meaning of the symbols and/or letter codes used in this figure.

Figure 6H-29. Crosswalk Closures and Pedestrian Detours (TA-29)

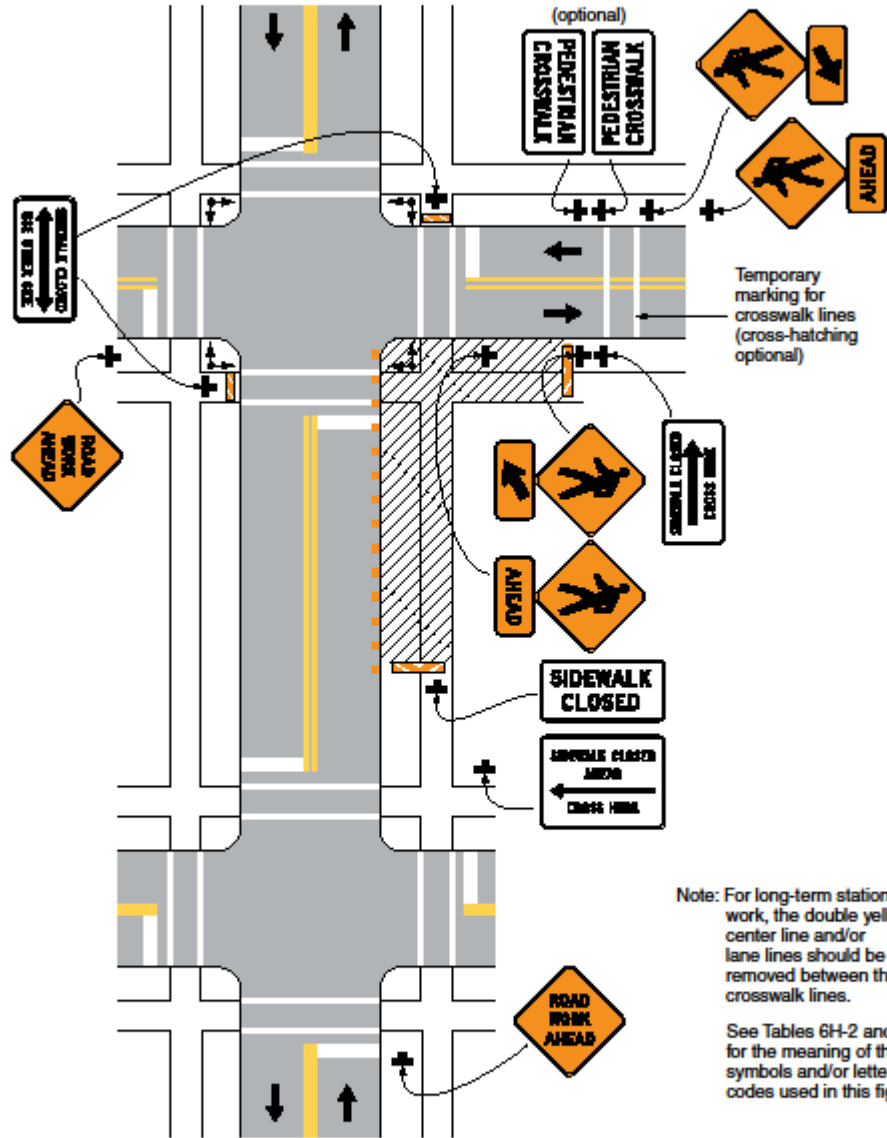

Typical Application 29

CITY OF ANN ARBOR
 DETAILED SPECIFICATION
 FOR
PROTECTING AND PRESERVING IRRIGATION SYSTEMS

AA:DAD

1 of 1

03/15/16

a. Description. This work shall consist of all labor, materials, and equipment necessary to investigate, locate, save and protect from damage, ensure continued and proper operation during the performance of the project work, re-establish operation as necessary, and upon completion of all project work, ensure that all existing sprinkler systems located within the project limits, or those affected by the project, are functioning in a satisfactory manner as determined by the Engineer.

b. Materials. None specified.

c. Construction. The Contractor shall be aware that properties located within the project limits have underground sprinkler systems that irrigate both private property and portions of the public right-of-way. The irrigation systems have been installed by a variety of private installers and may utilize several different materials and/or suppliers of the various components. Portions of the existing irrigation systems have been installed under paved areas, extend into landscaped islands, or may be required to be located within such areas at the conclusion of the project's construction.

The contractor shall perform the necessary investigations to determine the precise location of the irrigation systems, and all affected components, prior to the commencement of construction operations, determine all impacts to the systems that will result pursuant to the project's construction, and take the needed actions to ensure that the sprinkler systems will remain functional during the project's construction, and will be re-established in such a manner at appropriate intermediate and final project milestones, that the original functionality of the system is maintained to the greatest extent possible.

The Contractor shall contact all property owners prior to the commencement of the work in order to determine the impacts to their irrigation systems and coordinate the project's work with them to ensure satisfactory operation of the irrigation systems during construction.

All work shall be approved by the Engineer and the affected property owner(s) at the conclusion of the project's work.

d. Measurement and Payment. The completed work, as described, will be measured and paid for at the contract unit price for the following pay item:

<u>Contract Item (Pay Item)</u>	<u>Pay Unit</u>
Irrigation System, Protection and Maintenance	Dollar

The unit price for this item shall include all labor, material, and equipment costs required to complete the work.

CITY OF ANN ARBOR
DETAILED SPECIFICATION
FOR
ELECTRICAL AND COMMUNICATION HANDHOLES

AA:DAD

1 of 2

03/15/16

a. Description. This work shall consist of furnishing and installing traffic signal handholes and communication handhole assemblies at the locations shown in the Plans, or as directed by the Engineer. All work shall be completed in accordance with the current National Electric Code (NEC), section 819 of the Michigan Department of Transportation (MDOT) 2012 Standard Specifications for Construction, except as specified herein.

b. Materials. All materials shall be new and meet the requirements of the current IEEE, NEMA, ANSI Standards as applicable, and as specified herein.

The Contractor shall submit product data sheets for all handholes, covers and other parts for Engineer approval prior to ordering materials. The manufacturer "Quazite Composites," referenced below, is located in Lenoir City, Tennessee.

12 inch x 18 inch handhole assemblies shall consist of "Quazite Composites" box. The box shall be #PG1118BA12. The cover shall be, #PG1118HA41, a locking heavy-duty bolt-down type with a logo that reads "Street Lighting." The total depth of the handhole shall be 12 inches.

17 inch x 30 inch handhole assemblies shall consist of two, stacked "Quazite Composites" boxes. The lower box shall be #PG1730BB18. The upper box shall be #PG1730BA18. The cover shall be, #PG1730HA46, a locking heavy-duty bolt-down type with a logo that reads "Traffic Signal." The total depth of the handhole shall be 36 inches.

24 inch x 36 inch handhole assemblies shall consist of "Quazite Composites" box. The box shall be #PG2436BA24. The cover shall be, #PG2436HA12, a locking heavy-duty bolt-down type with a logo that reads "Street Lighting." The total depth of the handhole shall be 24 inches.

Provide Granular Material, CI II in accordance with section 902 of the MDOT 2012 Standard Specifications for Construction.

c. Construction. Handholes shall be placed at all junctions of traffic signal or electrical conduit, and as shown on the plans. Maximum distance between any two handholes shall be as shown on the Plans, but in no case shall exceed 500 feet.

Place foundation material consisting of four (4) inches of Granular Material, CI II compacted to 95% of its maximum unit weight.

Set the handhole or stacked units to the proper depth and elevation.

Connect handholes to new and existing conduits, whether shown on the plans or not. All conduits shall be connected to the handholes in accordance with the latest revision of Article 346 of the National Electrical Code (NEC).

Backfill around the perimeter of the handhole with Granular Material, CI II compacted to 95% of its maximum unit weight.

d. Measurement and Payment. The completed work, as described, will be measured and paid for at the contract unit prices for the following pay items:

<u>Pay Item</u>	<u>Pay Unit</u>
Handhole Assembly, 12 inch x 18 inch.....	Each
Handhole Assembly, 17 inch x 30 inch.....	Each
Handhole Assembly, 24 inch x 36 inch.....	Each

Handhole Assembly, ___ inch x ___ inch shall be paid for at their contract unit prices and shall include all labor, equipment, and materials to complete the work as specified herein.

The pay item shall also include the excavation and disposal of materials, furnishing, installing and compacting Granular Material, CI II, and all work related to connecting handholes to new and existing conduits, whether shown or not shown on the plans.

APPENDICES

Soil Boring Logs

Special Details

MDOT Special Provisions

MDOT Supplemental Specifications

MDOT Standard Plans



Client: City of Ann Arbor	PSI Project #: 0381193 Sheet: 1 of 1	Boring Log Number: BH-10	 Professional Service Industries, Inc.
Project: 2010 Road Construction Projects Birch Hollow Dr, Stone School to End	Location: City of Ann Arbor, Washtenaw County, Michigan		

Sample No./Type	Sample Location	Sample Recovery	Graphical Log	Elevation (ft)	Description of Material	Depth (ft)	Blows Per Foot	Moisture Content (%)	Plastic Limit (%)	Liquid Limit (%)	Dry Unit Wt (lb/cu.ft.)	<input checked="" type="checkbox"/> "N" Blows Per Foot 0 20 40 60 <input type="checkbox"/> Unconfined Compressive Strength (tsf) <input checked="" type="checkbox"/> Calibrated Hand Penetrometer (tsf) 0 2 4 6
				Surface Elevation:								
1PC					4.8" of ASPHALT							
					7" of SAND and GRAVEL BASE, fine to coarse, some silt, dark brown, moist							
					SILTY SAND (SM) - fine, brown, moist							
2SS					SILTY CLAY (CL) - few gravel, trace sand, mottled brown, orangish brown and gray, moist, hard	16	9					⊗
						57.9						
3SS						15	15					⊗
						5						⊗ 4.5+
					57.8							
					END OF BORING							
					Boring Location: East Bound Birch Hollow Drive 10' North of Curb, 122' West of Centerline to Chelsea Circle							

Note: The stratification lines indicated here are approximate. In-situ, the transition between soil types may be gradual.

<input checked="" type="checkbox"/> Water Level While Drilling <u>Dry</u> <input checked="" type="checkbox"/> Water Level At Completion <u>Dry</u> _____ After Completion	Boring Started: 10/14/2009	Completed: 10/14/2009	Engineer: KFD	
	Drilling Method: 3.25" HSA		Office: Plymouth	
	Driller: M. Dubnicki	Drill Rig: CME-75	Hole Depth (ft): 5.5	Approved:
	Note: Boring backfilled with auger cuttings unless otherwise noted.			

Client: City of Ann Arbor	PSI Project #: 0381193	Boring Log Number: BH-11	 <i>Professional Service Industries, Inc.</i>
Project: 2010 Road Construction Projects Birch Hollow Dr, Stone School to End	Sheet: 1 of 1	Location: City of Ann Arbor, Washtenaw County, Michigan	

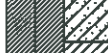
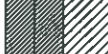
Sample No./Type	Sample Location	Sample Recovery	Graphical Log	Elevation (ft)	Description of Material	Depth (ft)	Blows Per Foot	Moisture Content (%)	Plastic Limit (%)	Liquid Limit (%)	Dry Unit Wt (lb/cu.ft.)	<input checked="" type="checkbox"/> "N" Blows Per Foot 0 20 40 60 <input type="checkbox"/> Unconfined Compressive Strength (tsf) <input checked="" type="checkbox"/> Calibrated Hand Penetrometer (tsf) 0 2 4 6
				Surface Elevation:								
1PC					3" of ASPHALT							
					7" of SAND and GRAVEL BASE, fine to coarse, some silt, dark brown, moist							
					CLAYEY SAND (SC) - fine to medium, few gravel, brown, moist, medium dense							
2SS					SILTY CLAY (CL) - trace sand, few gravel, mottled orangish brown and brown, moist, hard	15	9					⊗ 4.5*
						5.7,8						
3SS						14	15					⊗ 4.5*
						5						
					END OF BORING							
					Boring Location: West Bound Birch Hollow Drive 8' South of Curb, 107' East of Centerline to Chelsea Circle							

Note: The stratification lines indicated here are approximate. In-situ, the transition between soil types may be gradual.

<input checked="" type="checkbox"/> Water Level While Drilling <u>Dry</u> <input checked="" type="checkbox"/> Water Level At Completion <u>Dry</u> After Completion	Boring Started: 10/14/2009 Completed: 10/14/2009		Engineer: KFD	
	Drilling Method: 3.25" HSA		Office: Plymouth Drawn By: KFD	
	Driller: M. Dubnicki	Drill Rig: CME-75	Hole Depth (ft): 5.5	Approved: <i>Mez</i>
	Note: Boring backfilled with auger cuttings and patched with cold bituminous patch.			











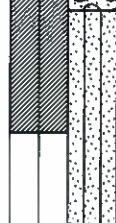
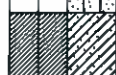
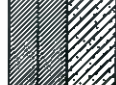

Client: City of Ann Arbor	PSI Project #: 0381193 Sheet: 1 of 1	Boring Log Number: BH-12	 Professional Service Industries, Inc.
Project: 2010 Road Construction Projects Birch Hollow Dr, Stone School to End	Location: City of Ann Arbor, Washtenaw County, Michigan		

Sample No./Type	Sample Location	Sample Recovery	Graphical Log	Elevation (ft)	Description of Material	Depth (ft)	Blows Per Foot	Moisture Content (%)	Plastic Limit (%)	Liquid Limit (%)	Dry Unit Wt (lb/cu.ft.)	<input checked="" type="checkbox"/> "N" Blows Per Foot 0 20 40 60 <input type="checkbox"/> Unconfined Compressive Strength (tsf) <input checked="" type="checkbox"/> Calibrated Hand Penetrometer (tsf) 0 2 4 6
				Surface Elevation:								
1PC					4" of ASPHALT							
					11" of SAND and GRAVEL BASE, fine to coarse, some silt, dark brown, moist							
2SS					SILTY CLAY (CL) - few gravel, trace sand, mottled brown, orangish brown and gray, moist, hard	11	16					⊗ ○*
						3.5,6						○*
3SS						17	17					⊗ ○*
						5						○*
					END OF BORING	5.8,9						
					Boring Location:							
					East Bound Birch Hollow Drive 5' North of Curb, 147' West of Centerline to Chelsea Circle							

Note: The stratification lines indicated here are approximate. In-situ, the transition between soil types may be gradual.

<input checked="" type="checkbox"/> Water Level While Drilling <u>Dry</u> <input checked="" type="checkbox"/> Water Level At Completion <u>Dry</u> After Completion	Boring Started: 10/14/2009 Completed: 10/14/2009	Engineer: KFD
	Drilling Method: 3.25" HSA	Office: Plymouth
	Driller: M. Dubnicki Drill Rig: CME-75	Hole Depth (ft): 5.5
	Approved: <i>[Signature]</i>	
Note: Boring backfilled with auger cuttings and patched with cold bituminous patch.		

Client: City of Ann Arbor	PSI Project #: 0381193 Sheet: 1 of 1	Boring Log Number: BH-6	 Professional Service Industries, Inc.
Project: 2010 Road Construction Projects Birch Hollow Dr, Stone School to End	Location: City of Ann Arbor, Washtenaw County, Michigan		

Sample No./Type	Sample Location	Sample Recovery	Graphical Log	Elevation (ft)	Description of Material	Depth (ft)	Blows Per Foot	Moisture Content (%)	Plastic Limit (%)	Liquid Limit (%)	Dry Unit Wt (lb/cu.ft.)	<input checked="" type="checkbox"/> "N" Blows Per Foot 0 20 40 60
												<input type="checkbox"/> Unconfined Compressive Strength (tsf) <input checked="" type="checkbox"/> Calibrated Hand Penetrometer (tsf) 0 2 4 6
1PC					Surface Elevation: 3.5" of ASPHALT							
					18" of SAND and GRAVEL BASE, fine to coarse, some silt, dark brown, moist							
2SS					SILTY SAND (SM) - fine, few gravel, mottled brown and orangish brown, moist, medium dense	15	14					⊗
						5.6.9						
3SS					SANDY CLAY (CL) - few gravel, grayish brown, moist, hard	15	11					⊗
						5						⊗
						6.7.8						⊗
					END OF BORING							⊗
												⊗
												⊗
												⊗
												⊗
												⊗
												⊗

Note: The stratification lines indicated here are approximate. In-situ, the transition between soil types may be gradual.

<input checked="" type="checkbox"/> Water Level While Drilling <u>Dry</u> <input checked="" type="checkbox"/> Water Level At Completion <u>Dry</u> After Completion	Boring Started: 10/14/2009 Completed: 10/14/2009	Engineer: KFD
	Drilling Method: 3.25" HSA	Office: Plymouth
	Driller: M. Dubnicki Drill Rig: CME-75	Hole Depth (ft): 5.5
	Approved: <i>[Signature]</i>	
Note: Boring backfilled with auger cuttings and patched with cold bituminous patch.		

Client: City of Ann Arbor	PSI Project #: 0381193	Boring Log Number: BH-7	 Professional Service Industries, Inc.
Project: 2010 Road Construction Projects Birch Hollow Dr, Stone School to End	Sheet: 1 of 1	Location: City of Ann Arbor, Washtenaw County, Michigan	

Sample No./Type	Sample Location	Sample Recovery	Graphical Log	Elevation (ft)	Description of Material	Depth (ft)	Blows Per Foot	Moisture Content (%)	Plastic Limit (%)	Liquid Limit (%)	Dry Unit Wt (lb/cu.ft.)	<input checked="" type="checkbox"/> "N" Blows Per Foot 0 20 40 60 <input type="checkbox"/> Unconfined Compressive Strength (tsf) <input checked="" type="checkbox"/> Calibrated Hand Penetrometer (tsf) 0 2 4 6
Surface Elevation:												
1PC					3.3" of ASPHALT							
					8" of SAND and GRAVEL BASE, fine to coarse, some silt, dark brown, moist							
					SILTY SAND (SM) - fine, brown, moist							
2SS						27	7					
					SILTY SAND (SP-SM) - fine to coarse, brown, moist, medium dense	7.15, 12						
3SS						14	9					
					END OF BORING	5						
						10.7.7						

Boring Location:
 West Bound Birch Hollow Drive
 11' South of Curb, 472' East of Centerline to
 Stone School Road

Note: The stratification lines indicated here are approximate. In-situ, the transition between soil types may be gradual.

<input checked="" type="checkbox"/> Water Level While Drilling <u>Dry</u> <input checked="" type="checkbox"/> Water Level At Completion <u>Dry</u> After Completion	Boring Started: 10/14/2009	Completed: 10/14/2009	Engineer: KFD	
	Drilling Method: 3.25" HSA		Office: Plymouth	
	Driller: M. Dubnicki	Drill Rig: CME-75	Hole Depth (ft): 5.5	Approved: <i>[Signature]</i>
	Note: Boring backfilled with auger cuttings and patched with cold bituminous patch.			

Client: City of Ann Arbor	PSI Project #: 0381193 Sheet: 1 of 1	Boring Log Number: BH-8	 Professional Service Industries, Inc.
Project: 2010 Road Construction Projects Birch Hollow Dr, Stone School to End		Location: City of Ann Arbor, Washtenaw County, Michigan	

Sample No./Type	Sample Location	Sample Recovery	Graphical Log	Elevation (ft)	Description of Material	Depth (ft)	Blows Per Foot	Moisture Content (%)	Plastic Limit (%)	Liquid Limit (%)	Dry Unit Wt (lb/cu.ft.)
					Surface Elevation:						
1PC					3.5" of ASPHALT						
					SILTY SAND (SP-SM) - fine to medium, few gravel, brown, moist, medium dense						
2SS						19	5				
						8,9,10					
3SS						22	5				
						5					
						10,10,12					
					END OF BORING						
					Boring Location:						
					East Bound Birch Hollow Drive						
					2' North of Curb, 242' West of Centerline to						
					Chelsea Circle						

Note: The stratification lines indicated here are approximate. In-situ, the transition between soil types may be gradual.

<input type="checkbox"/> Water Level While Drilling <u>Dry</u> <input type="checkbox"/> Water Level At Completion <u>Dry</u> After Completion	Boring Started: 10/14/2009 Completed: 10/14/2009 Drilling Method: 3.25" HSA Office: Plymouth Driller: M. Dubnicki Drill Rig: CME-75 Hole Depth (ft): 5.5	Engineer: KFD Drawn By: KFD Approved: <i>[Signature]</i>
Note: Boring backfilled with auger cuttings and patched with cold bituminous patch.		

Client: City of Ann Arbor	PSI Project #: 0381193	Boring Log Number: BH-9	 Professional Service Industries, Inc.
Project: 2010 Road Construction Projects Birch Hollow Dr, Stone School to End	Sheet: 1 of 1	Location: City of Ann Arbor, Washtenaw County, Michigan	

Sample No./Type	Sample Location	Sample Recovery	Graphical Log	Elevation (ft)	Description of Material	Depth (ft)	Blows Per Foot	Moisture Content (%)	Plastic Limit (%)	Liquid Limit (%)	Dry Unit Wt (lb/cu.ft.)	<input checked="" type="checkbox"/> "N" Blows Per Foot 0 20 40 60 <input type="checkbox"/> Unconfined Compressive Strength (tsf) <input checked="" type="checkbox"/> Calibrated Hand Penetrometer (tsf) 0 2 4 6
				Surface Elevation:								
1PC					5" of ASPHALT							
					SILTY SAND (SP-SM) - fine to coarse, few gravel, brown, moist, medium dense							
2SS						15	6					⊗
						5.8.9						
3SS					SILTY CLAY (CL) - few gravel, trace sand, mottled brown, orangish brown and gray, moist, hard	20	15					⊗
						5						⊗ 4.5+
						7.9.11						
					END OF BORING							
Boring Location:					West Bound Birch Hollow Drive 6' South of Curb, 37' West of Centerline to Chelsea Circle							

Note: The stratification lines indicated here are approximate. In-situ, the transition between soil types may be gradual.

<input checked="" type="checkbox"/> Water Level While Drilling <u>Dry</u> <input checked="" type="checkbox"/> Water Level At Completion <u>Dry</u> After Completion	Boring Started: 10/14/2009 Completed: 10/14/2009		Engineer: KFD
	Drilling Method: 3.25" HSA		Office: Plymouth
	Driller: M. Dubnicki	Drill Rig: CME-75	Hole Depth (ft): 5.5
	Note: Boring backfilled with auger cuttings and patched with cold bituminous patch.		



CTI and Associates Inc

CLIENT City of Ann Arbor
PROJECT NUMBER 3122040060-1
DATE STARTED 10/11/12 **COMPLETED** 10/11/12
DRILLING CONTRACTOR Stearns Drilling
DRILLING METHOD 2-1/4 inch HSA
LOGGED BY G. Geerlings **CHECKED BY** T. Marsik
NOTES Boring backfilled with auger cuttings and patched.

PROJECT NAME 2012 Ann Arbor Misc. Geotechnical Services - North Area Borings
PROJECT LOCATION Ann Arbor, Michigan
GROUND ELEVATION N/A
GROUND WATER LEVELS:
DURING DRILLING None
AFTER DRILLING None
COLLAPSE DEPTH 3' 6"

DEPTH (ft)	GRAPHIC LOG	MATERIAL DESCRIPTION	SAMPLE TYPE NUMBER	RECOVERY % (RQD)	BLOW COUNTS (N VALUE)	POCKET PEN. (tsf) UNC. STRENGTH (psf)	NATURAL MOISTURE CONTENT (%)	▲ SPT N VALUE ▲		
								20	40	60
0.0		8 inches of ASPHALT PAVEMENT								
2.5		Brown moist silty fine to medium SAND with some gravel and occasional cobbles - (FILL)	GB	100						
			SS 1	100	12-14-15 (29)					
5.0		Dark brown moist loose silty fine SAND with some organics - (SM)	SS 2	28	6-5-4 (9)					

Bottom of borehole at 5.0 feet.

Boring performed 25' north of curb, 3' west of driveway to 106 Depot Street



CTI and Associates Inc

CLIENT City of Ann Arbor
PROJECT NUMBER 3122040060-1
DATE STARTED 10/11/12 **COMPLETED** 10/11/12
DRILLING CONTRACTOR Stearns Drilling
DRILLING METHOD 2-1/4 inch HSA
LOGGED BY G. Geerlings **CHECKED BY** T. Marsik
NOTES Boring backfilled with auger cuttings and patched.

PROJECT NAME 2012 Ann Arbor Misc. Geotechnical Services - North Area Borings
PROJECT LOCATION Ann Arbor, Michigan
GROUND ELEVATION N/A
GROUND WATER LEVELS:
DURING DRILLING None
AFTER DRILLING None
COLLAPSE DEPTH 3' 6"

DEPTH (ft)	GRAPHIC LOG	MATERIAL DESCRIPTION	SAMPLE TYPE NUMBER	RECOVERY % (RQD)	BLOW COUNTS (N VALUE)	POCKET PEN. (tsf) UNC. STRENGTH (psf)	NATURAL MOISTURE CONTENT (%)	▲ SPT N VALUE ▲	
								PL	MC LL
0.0		8 inches of ASPHALT PAVEMENT						20 40 60 80	
		4 inches of brown moist silty fine to medium SAND with some gravel - (FILL)	GB	100				20 40 60 80	
		Brown moist fine to medium SAND with some gravel and silt - (FILL)	SS 1	100	16-21-18 (39)			20 40 60 80	
2.5		Brown moist silty fine to coarse SAND with gravel - (FILL)							
			SS 2	94	9-11-6 (17)				
5.0		Dark brown and brown variegated moist CLAY with silt, some organics and trace of sand - (CL-OL) Organic Content = 8.4%					14		

Bottom of borehole at 5.0 feet.

Boring performed 5' south of curb, 6' west of east side of Fourth Avenue



CTI and Associates Inc

BORING NUMBER: Depot B-3

PAGE 1 OF 1

CLIENT City of Ann Arbor
PROJECT NUMBER 3122040060-1
DATE STARTED 10/11/12 **COMPLETED** 10/11/12
DRILLING CONTRACTOR Stearns Drilling
DRILLING METHOD 2-1/4 inch HSA
LOGGED BY G. Geerlings **CHECKED BY** T. Marsik
NOTES Boring backfilled with auger cuttings and patched.

PROJECT NAME 2012 Ann Arbor Misc. Geotechnical Services - North Area Borings
PROJECT LOCATION Ann Arbor, Michigan
GROUND ELEVATION N/A
GROUND WATER LEVELS:
DURING DRILLING None
AFTER DRILLING None
COLLAPSE DEPTH 3' 6"

DEPTH (ft)	GRAPHIC LOG	MATERIAL DESCRIPTION	SAMPLE TYPE NUMBER	RECOVERY % (RQD)	BLOW COUNTS (N VALUE)	POCKET PEN. (tsf) UNC. STRENGTH (psf)	NATURAL MOISTURE CONTENT (%)	▲ SPT N VALUE ▲						
								20	40	60	80			
0.0		7 inches of ASPHALT PAVEMENT												
		Brown moist silty fine to medium SAND with gravel - (FILL)	GB	100										
		Brown moist fine to medium SAND with some gravel and silt - (FILL)	SS 1	100	20-28-26 (54)									
2.5		Brown moist fine to medium SAND with some gravel and silt - (FILL)												
		Dark brown moist medium dense silty fine SAND with some organics - (SM)	SS 2	100	11-5-5 (10)									
5.0														

Bottom of borehole at 5.0 feet.

Boring performed 10' south of curb, 40' west of Fifth Avenue



CTI and Associates Inc

BORING NUMBER: Depot B-4

PAGE 1 OF 1

CLIENT City of Ann Arbor
PROJECT NUMBER 3122040060-1
DATE STARTED 10/11/12 **COMPLETED** 10/11/12
DRILLING CONTRACTOR Stearns Drilling
DRILLING METHOD 2-1/4 inch HSA
LOGGED BY G. Geerlings **CHECKED BY** T. Marsik
NOTES Boring backfilled with auger cuttings and patched.

PROJECT NAME 2012 Ann Arbor Misc. Geotechnical Services - North Area Borings
PROJECT LOCATION Ann Arbor, Michigan
GROUND ELEVATION N/A
GROUND WATER LEVELS:
DURING DRILLING None
AFTER DRILLING None
COLLAPSE DEPTH 3' 6"

DEPTH (ft)	GRAPHIC LOG	MATERIAL DESCRIPTION	SAMPLE TYPE NUMBER	RECOVERY % (RQD)	BLOW COUNTS (N VALUE)	POCKET PEN. (tsf) UNC. STRENGTH (psf)	NATURAL MOISTURE CONTENT (%)	▲ SPT N VALUE ▲	
								PL	MC LL
0.0								20 40 60 80	20 40 60 80
0.0 - 0.8		8 inches of ASPHALT PAVEMENT							
0.8 - 1.2		8 inches of brown moist silty fine to medium SAND with some gravel - (FILL)	GB	100					
1.2 - 2.5		Brown moist fine to medium SAND with some gravel and silt - (FILL)	SS 1	100	13-15-20 (35)				
2.5 - 5.0		Brown moist medium dense silty fine to coarse SAND with gravel - (SM)	SS 2	89	16-12-10 (22)				

Bottom of borehole at 5.0 feet.

Boring performed 28' north of curb, 5' west of Amtrak Station parking lot entrance



CTI and Associates Inc

BORING NUMBER: Green B-1

PAGE 1 OF 1

CLIENT City of Ann Arbor
PROJECT NUMBER 3122040060-1
DATE STARTED 10/3/12 **COMPLETED** 10/3/12
DRILLING CONTRACTOR Stearns Drilling
DRILLING METHOD 2-1/4 inch HSA
LOGGED BY G. Geerlings **CHECKED BY** T. Marsik
NOTES Boring backfilled with auger cuttings and patched.

PROJECT NAME 2012 Ann Arbor Misc. Geotechnical Services - North Area Borings
PROJECT LOCATION Ann Arbor, Michigan
GROUND ELEVATION N/A
GROUND WATER LEVELS:
DURING DRILLING None
AFTER DRILLING None
COLLAPSE DEPTH 3' 6"

DEPTH (ft)	GRAPHIC LOG	MATERIAL DESCRIPTION	SAMPLE TYPE NUMBER	RECOVERY % (RQD)	BLOW COUNTS (N VALUE)	POCKET PEN. (tsf) UNC. STRENGTH (psf)	NATURAL MOISTURE CONTENT (%)	▲ SPT N VALUE ▲							
								20	40	60	80				
0.0		4 inches of ASPHALT PAVEMENT													
		12 inches of gray moist crushed LIMESTONE - (FILL)	GB	100											
		Brown moist medium dense fine to medium SAND with traces of gravel and silt - (SP)	SS 1	67	11-11-11 (22)										
2.5		Brown and dark gray variegated moist very stiff CLAY with silt, traces of gravel and sand and occasional sand partings - (CL)	SS 2	100	3-4-4 (8)	3.25									
5.0							12								

Bottom of borehole at 5.0 feet.

Boring performed 9' south of curb, 55' east of Nixon Road



CTI and Associates Inc

BORING NUMBER: Green B-10

PAGE 1 OF 1

CLIENT City of Ann Arbor
PROJECT NUMBER 3122040060-1
DATE STARTED 10/3/12 **COMPLETED** 10/3/12
DRILLING CONTRACTOR Stearns Drilling
DRILLING METHOD 2-1/4 inch HSA
LOGGED BY G. Geerlings **CHECKED BY** T. Marsik
NOTES Boring backfilled with auger cuttings and patched.

PROJECT NAME 2012 Ann Arbor Misc. Geotechnical Services - North Area Borings
PROJECT LOCATION Ann Arbor, Michigan
GROUND ELEVATION N/A
GROUND WATER LEVELS:
DURING DRILLING None
AFTER DRILLING None
COLLAPSE DEPTH 3' 6"

DEPTH (ft)	GRAPHIC LOG	MATERIAL DESCRIPTION	SAMPLE TYPE NUMBER	RECOVERY % (RQD)	BLOW COUNTS (N VALUE)	POCKET PEN. (tsf) UNC. STRENGTH (psf)	NATURAL MOISTURE CONTENT (%)	▲ SPT N VALUE ▲						
								20	40	60	80			
0.0		6 inches of ASPHALT PAVEMENT												
		12 inches of gray moist crushed LIMESTONE - (FILL)	GB	100										
		Brown moist loose fine to coarse SAND with some silt and trace of gravel - (FILL)	SS 1	100	5-4-6 (10)									
2.5		Brown and gray variegated moist stiff to medium stiff CLAY with silt and traces of gravel and sand - (CL)												
			SS 2	89	1-2-2 (4)	0.75								
5.0							16							

Bottom of borehole at 5.0 feet.

Boring performed 17' north of curb, 45' west of Light Pole AAGRN15



CTI and Associates Inc

BORING NUMBER: Green B-11

PAGE 1 OF 1

CLIENT City of Ann Arbor
PROJECT NUMBER 3122040060-1
DATE STARTED 10/3/12 **COMPLETED** 10/3/12
DRILLING CONTRACTOR Stearns Drilling
DRILLING METHOD 2-1/4 inch HSA
LOGGED BY G. Geerlings **CHECKED BY** T. Marsik
NOTES Boring backfilled with auger cuttings and patched.

PROJECT NAME 2012 Ann Arbor Misc. Geotechnical Services - North Area Borings
PROJECT LOCATION Ann Arbor, Michigan
GROUND ELEVATION N/A
GROUND WATER LEVELS:
DURING DRILLING None
AFTER DRILLING None
COLLAPSE DEPTH 3' 6"

DEPTH (ft)	GRAPHIC LOG	MATERIAL DESCRIPTION	SAMPLE TYPE NUMBER	RECOVERY % (RQD)	BLOW COUNTS (N VALUE)	POCKET PEN. (tsf) UNC. STRENGTH (psf)	NATURAL MOISTURE CONTENT (%)	▲ SPT N VALUE ▲						
								20	40	60	80			
0.0		5 inches of ASPHALT PAVEMENT												
		7 inches of gray moist crushed LIMESTONE - (FILL)	GB	100										
		Brown moist medium dense fine to medium SAND with traces of gravel and silt and occasional clay seams - (FILL)	SS 1	100	9-11-15 (26)									
2.5														
			SS 2	100	6-7-9 (16)									
5.0														

Bottom of borehole at 5.0 feet.

Boring performed 4' north of curb, 57' east of Light Pole AAGR16



CTI and Associates Inc

BORING NUMBER: Green B-12

PAGE 1 OF 1

CLIENT City of Ann Arbor
PROJECT NUMBER 3122040060-1
DATE STARTED 10/4/12 **COMPLETED** 10/4/12
DRILLING CONTRACTOR Stearns Drilling
DRILLING METHOD 2-1/4 inch HSA
LOGGED BY G. Geerlings **CHECKED BY** T. Marsik
NOTES Boring backfilled with auger cuttings and patched.

PROJECT NAME 2012 Ann Arbor Misc. Geotechnical Services - North Area Borings
PROJECT LOCATION Ann Arbor, Michigan
GROUND ELEVATION N/A
GROUND WATER LEVELS:
DURING DRILLING None
AFTER DRILLING None
COLLAPSE DEPTH 3' 6"

DEPTH (ft)	GRAPHIC LOG	MATERIAL DESCRIPTION	SAMPLE TYPE NUMBER	RECOVERY % (RQD)	BLOW COUNTS (N VALUE)	POCKET PEN. (tsf) UNC. STRENGTH (psf)	NATURAL MOISTURE CONTENT (%)	▲ SPT N VALUE ▲		
								20	40	60
0.0		7 inches of ASPHALT PAVEMENT								
		11 inches of gray moist crushed LIMESTONE - (FILL)	GB	100						
		Brown moist loose fine to coarse SAND with some silt and trace of gravel - (FILL)	SS 1	100	5-3-5 (8)	3.0				
2.5		Brown and gray variegated moist very stiff CLAY with silt and traces of gravel and sand - (CL)					14			
		Gray moist very stiff CLAY with silt and traces of gravel and sand - (CL)	SS 2	100	3-7-6 (13)	3.0				
5.0							11			

Bottom of borehole at 5.0 feet.

Boring performed 15' south of curb, 23' east of Kilburn Park Court



CTI and Associates Inc

BORING NUMBER: Green B-13

PAGE 1 OF 1

CLIENT City of Ann Arbor
PROJECT NUMBER 3122040060-1
DATE STARTED 10/4/12 **COMPLETED** 10/4/12
DRILLING CONTRACTOR Stearns Drilling
DRILLING METHOD 2-1/4 inch HSA
LOGGED BY G. Geerlings **CHECKED BY** T. Marsik
NOTES Boring backfilled with auger cuttings and patched.

PROJECT NAME 2012 Ann Arbor Misc. Geotechnical Services - North Area Borings
PROJECT LOCATION Ann Arbor, Michigan
GROUND ELEVATION N/A
GROUND WATER LEVELS:
DURING DRILLING None
AFTER DRILLING None
COLLAPSE DEPTH 3' 6"

DEPTH (ft)	GRAPHIC LOG	MATERIAL DESCRIPTION	SAMPLE TYPE NUMBER	RECOVERY % (RQD)	BLOW COUNTS (N VALUE)	POCKET PEN. (tsf) UNC. STRENGTH (psf)	NATURAL MOISTURE CONTENT (%)	▲ SPT N VALUE ▲						
								20	40	60	80			
0.0		6 inches of ASPHALT PAVEMENT												
		12 inches of gray moist crushed LIMESTONE - (FILL)	GB	100										
		6 inches of brown moist fine to coarse SAND with some silt and trace of gravel - (FILL)	SS 1	89	6-4-5 (9)	1.75								
2.5		Brown and gray variegated moist stiff CLAY with silt and traces of gravel and sand - (CL)					11							
			SS 2	56	5-5-5 (10)									
5.0							15							

Bottom of borehole at 5.0 feet.

Boring performed 18' south of curb, 100' west of Burbank Drive



CTI and Associates Inc

BORING NUMBER: Green B-14

PAGE 1 OF 1

CLIENT City of Ann Arbor
PROJECT NUMBER 3122040060-1
DATE STARTED 10/4/12 **COMPLETED** 10/4/12
DRILLING CONTRACTOR Stearns Drilling
DRILLING METHOD 2-1/4 inch HSA
LOGGED BY G. Geerlings **CHECKED BY** T. Marsik
NOTES Boring backfilled with auger cuttings and patched.

PROJECT NAME 2012 Ann Arbor Misc. Geotechnical Services - North Area Borings
PROJECT LOCATION Ann Arbor, Michigan
GROUND ELEVATION N/A
GROUND WATER LEVELS:
DURING DRILLING None
AFTER DRILLING None
COLLAPSE DEPTH 3' 6"

DEPTH (ft)	GRAPHIC LOG	MATERIAL DESCRIPTION	SAMPLE TYPE NUMBER	RECOVERY % (RQD)	BLOW COUNTS (N VALUE)	POCKET PEN. (tsf) UNC. STRENGTH (psf)	NATURAL MOISTURE CONTENT (%)	▲ SPT N VALUE ▲		
								20	40	60
0.0		6 inches of ASPHALT PAVEMENT								
		12 inches of gray moist crushed LIMESTONE - (FILL)	GB	100						
		6 inches of brown moist fine to coarse SAND with some silt and trace of gravel - (FILL)	SS 1	100	8-9-7 (16)	1.0				
2.5		Brown and gray variegated very moist stiff CLAY with silt and traces of gravel and sand - (CL)					11			
		Brown and dark gray variegated moist hard CLAY with silt, traces of gravel and sand and occasional sand partings - (CL)	SS 2	100	4-8-11 (19)	4.5+				
5.0							11			

Bottom of borehole at 5.0 feet.

Boring performed 6' west of curb, 44' north of Light Pole S25AL014



CTI and Associates Inc

BORING NUMBER: Green B-15

PAGE 1 OF 1

CLIENT City of Ann Arbor
PROJECT NUMBER 3122040060-1
DATE STARTED 10/4/12 **COMPLETED** 10/4/12
DRILLING CONTRACTOR Stearns Drilling
DRILLING METHOD 2-1/4 inch HSA
LOGGED BY G. Geerlings **CHECKED BY** T. Marsik
NOTES Boring backfilled with auger cuttings and patched.

PROJECT NAME 2012 Ann Arbor Misc. Geotechnical Services - North Area Borings
PROJECT LOCATION Ann Arbor, Michigan
GROUND ELEVATION N/A
GROUND WATER LEVELS:
DURING DRILLING None
AFTER DRILLING None
COLLAPSE DEPTH 3' 6"

DEPTH (ft)	GRAPHIC LOG	MATERIAL DESCRIPTION	SAMPLE TYPE NUMBER	RECOVERY % (RQD)	BLOW COUNTS (N VALUE)	POCKET PEN. (tsf) UNC. STRENGTH (psf)	NATURAL MOISTURE CONTENT (%)	▲ SPT N VALUE ▲							
								20	40	60	80				
0.0		6 inches of ASPHALT PAVEMENT													
		12 inches of gray moist crushed LIMESTONE - (FILL)	GB	100											
		Brown moist medium dense fine to coarse SAND with traces of gravel and silt - (SP-SM)	SS 1	100	11-11-7 (18)										
2.5		Brown and gray variegated moist hard CLAY with silt, traces of gravel and sand and occasional sand partings - (CL)													
			SS 2	89	3-5-8 (13)	4.5+									
5.0							13								

Bottom of borehole at 5.0 feet.

Boring performed 17' west of curb, 6' south of Light Pole S25AL013



CTI and Associates Inc

BORING NUMBER: Green B-16

PAGE 1 OF 1

CLIENT City of Ann Arbor
PROJECT NUMBER 3122040060-1
DATE STARTED 10/4/12 **COMPLETED** 10/4/12
DRILLING CONTRACTOR Stearns Drilling
DRILLING METHOD 2-1/4 inch HSA
LOGGED BY G. Geerlings **CHECKED BY** T. Marsik
NOTES Boring backfilled with auger cuttings and patched.

PROJECT NAME 2012 Ann Arbor Misc. Geotechnical Services - North Area Borings
PROJECT LOCATION Ann Arbor, Michigan
GROUND ELEVATION N/A
GROUND WATER LEVELS:
DURING DRILLING None
AFTER DRILLING None
COLLAPSE DEPTH 3' 6"

DEPTH (ft)	GRAPHIC LOG	MATERIAL DESCRIPTION	SAMPLE TYPE NUMBER	RECOVERY % (RQD)	BLOW COUNTS (N VALUE)	POCKET PEN. (tsf) UNC. STRENGTH (psf)	NATURAL MOISTURE CONTENT (%)	▲ SPT N VALUE ▲		
								20	40	60
0.0		6 inches of ASPHALT PAVEMENT								
		12 inches of gray moist crushed LIMESTONE - (FILL)	GB	100						
		Brown moist medium dense fine to coarse SAND with some silt and trace of gravel - (FILL)	SS 1	100	11-9-8 (17)	4.5+				
2.5		Brown and dark gray variegated moist hard CLAY with silt, traces of gravel and sand and occasional sand partings - (CL)					15			
			SS 2	100	6-7-10 (17)	4.5+				
5.0							14			

Bottom of borehole at 5.0 feet.

Boring performed 6' east of curb, 120' south of Light Pole S25AL012



CTI and Associates Inc

BORING NUMBER: Green B-17

PAGE 1 OF 1

CLIENT City of Ann Arbor
PROJECT NUMBER 3122040060-1
DATE STARTED 10/4/12 **COMPLETED** 10/4/12
DRILLING CONTRACTOR Stearns Drilling
DRILLING METHOD 2-1/4 inch HSA
LOGGED BY G. Geerlings **CHECKED BY** T. Marsik
NOTES Boring backfilled with auger cuttings and patched.

PROJECT NAME 2012 Ann Arbor Misc. Geotechnical Services - North Area Borings
PROJECT LOCATION Ann Arbor, Michigan
GROUND ELEVATION N/A
GROUND WATER LEVELS:
DURING DRILLING None
AFTER DRILLING None
COLLAPSE DEPTH 3' 6"

DEPTH (ft)	GRAPHIC LOG	MATERIAL DESCRIPTION	SAMPLE TYPE NUMBER	RECOVERY % (RQD)	BLOW COUNTS (N VALUE)	POCKET PEN. (tsf) UNC. STRENGTH (psf)	NATURAL MOISTURE CONTENT (%)	▲ SPT N VALUE ▲		
								20	40	60
0.0		5 inches of ASPHALT PAVEMENT								
		12 inches of gray crushed LIMESTONE - (FILL)	GB	100						
		Brown moist loose fine to coarse SAND with some silt and traces of gravel - (FILL)	SS 1	100	9-6-3 (9)	1.25				
2.5		Brown and gray variegated very moist stiff CLAY with silt, traces of gravel and sand and occasional sand partings - (CL)					25			
		Brown and gray variegated moist hard CLAY with silt, traces of gravel and sand and occasional sand partings - (CL)	SS 2	100	4-7-10 (17)	4.5+				
5.0							15			

Bottom of borehole at 5.0 feet.

Boring performed 8' east of curb, across from 3350 Burbank Drive



CTI and Associates Inc

BORING NUMBER: Green B-18

PAGE 1 OF 1

CLIENT City of Ann Arbor
PROJECT NUMBER 3122040060-1
DATE STARTED 10/4/12 **COMPLETED** 10/4/12
DRILLING CONTRACTOR Stearns Drilling
DRILLING METHOD 2-1/4 inch HSA
LOGGED BY G. Geerlings **CHECKED BY** T. Marsik
NOTES Boring backfilled with auger cuttings and patched.

PROJECT NAME 2012 Ann Arbor Misc. Geotechnical Services - North Area Borings
PROJECT LOCATION Ann Arbor, Michigan
GROUND ELEVATION N/A
GROUND WATER LEVELS:
DURING DRILLING None
AFTER DRILLING None
COLLAPSE DEPTH 3' 6"

DEPTH (ft)	GRAPHIC LOG	MATERIAL DESCRIPTION	SAMPLE TYPE NUMBER	RECOVERY % (RQD)	BLOW COUNTS (N VALUE)	POCKET PEN. (tsf) UNC. STRENGTH (psf)	NATURAL MOISTURE CONTENT (%)	▲ SPT N VALUE ▲							
								20	40	60	80				
0.0		6 inches of ASPHALT PAVEMENT													
		12 inches of gray moist crushed LIMESTONE - (FILL)	GB	100											
		Brown moist medium dense fine to coarse SAND with some silt and traces of gravel - (FILL)	SS 1	100	12-10-8 (18)	1.25									
2.5		Brown and gray variegated very moist stiff CLAY with silt and traces of gravel and sand - (CL)					15								
		Brown moist hard CLAY with silt, traces of gravel and sand and occasional sand partings - (CL)	SS 2	100	4-6-8 (14)	4.5+									
5.0							11								

Bottom of borehole at 5.0 feet.

Boring performed 9' east of curb, 80' south of Light Pole S25AL009



CTI and Associates Inc

BORING NUMBER: Green B-2

PAGE 1 OF 1

CLIENT City of Ann Arbor
PROJECT NUMBER 3122040060-1
DATE STARTED 10/3/12 **COMPLETED** 10/3/12
DRILLING CONTRACTOR Stearns Drilling
DRILLING METHOD 2-1/4 inch HSA
LOGGED BY G. Geerlings **CHECKED BY** T. Marsik
NOTES Boring backfilled with auger cuttings and patched.

PROJECT NAME 2012 Ann Arbor Misc. Geotechnical Services - North Area Borings
PROJECT LOCATION Ann Arbor, Michigan
GROUND ELEVATION N/A
GROUND WATER LEVELS:
DURING DRILLING None
AFTER DRILLING None
COLLAPSE DEPTH 3' 6"

DEPTH (ft)	GRAPHIC LOG	MATERIAL DESCRIPTION	SAMPLE TYPE NUMBER	RECOVERY % (RQD)	BLOW COUNTS (N VALUE)	POCKET PEN. (tsf) UNC. STRENGTH (psf)	NATURAL MOISTURE CONTENT (%)	▲ SPT N VALUE ▲						
								20	40	60	80			
0.0		5 inches of ASPHALT PAVEMENT												
		7 inches of gray moist crushed LIMESTONE - (FILL)	GB	100										
		Brown moist loose fine to medium SAND with traces of gravel and silt - (SP)	SS 1	100	4-4-10 (14)	1.75								
2.5		Brown and gray variegated very moist stiff CLAY with silt and traces of gravel and sand - (CL)					14							
		Brown and dark gray variegated moist very stiff CLAY with silt, traces of gravel and sand and occasional sand seams - (CL)	SS 2	100	4-9-9 (18)	2.25								
5.0							15							

Bottom of borehole at 5.0 feet.

Boring performed 15-1/2' north of curb, 135' east of Maitland Drive (west)



CTI and Associates Inc

BORING NUMBER: Green B-3

PAGE 1 OF 1

CLIENT City of Ann Arbor
PROJECT NUMBER 3122040060-1
DATE STARTED 10/3/12 **COMPLETED** 10/3/12
DRILLING CONTRACTOR Stearns Drilling
DRILLING METHOD 2-1/4 inch HSA
LOGGED BY G. Geerlings **CHECKED BY** T. Marsik
NOTES Boring backfilled with auger cuttings and patched.

PROJECT NAME 2012 Ann Arbor Misc. Geotechnical Services - North Area Borings
PROJECT LOCATION Ann Arbor, Michigan
GROUND ELEVATION N/A
GROUND WATER LEVELS:
DURING DRILLING None
AFTER DRILLING None
COLLAPSE DEPTH 3' 6"

DEPTH (ft)	GRAPHIC LOG	MATERIAL DESCRIPTION	SAMPLE TYPE NUMBER	RECOVERY % (RQD)	BLOW COUNTS (N VALUE)	POCKET PEN. (tsf) UNC. STRENGTH (psf)	NATURAL MOISTURE CONTENT (%)	▲ SPT N VALUE ▲						
								20	40	60	80			
0.0		5 inches of ASPHALT PAVEMENT												
		7 inches of gray moist crushed LIMESTONE - (FILL)	GB	100										
		Brown moist medium dense fine to medium SAND with traces of gravel and silt - (SP)	SS 1	100	6-5-3 (8)	0.75								
2.5		Brown and gray variegated very moist medium stiff CLAY with silt and traces of gravel and sand - (CL)					13							
		Brown and dark gray variegated moist hard CLAY with silt and traces of gravel and sand and occasional sand partings - (CL)	SS 2	100	2-7-9 (16)	4.5+								
5.0							13							

Bottom of borehole at 5.0 feet.

Boring performed 6' north of curb, 60' east of Maitland Drive (east)



CTI and Associates Inc

BORING NUMBER: Green B-4

PAGE 1 OF 1

CLIENT City of Ann Arbor
PROJECT NUMBER 3122040060-1
DATE STARTED 10/4/12 **COMPLETED** 10/4/12
DRILLING CONTRACTOR Stearns Drilling
DRILLING METHOD 2-1/4 inch HSA
LOGGED BY G. Geerlings **CHECKED BY** T. Marsik
NOTES Boring backfilled with auger cuttings and patched.

PROJECT NAME 2012 Ann Arbor Misc. Geotechnical Services - North Area Borings
PROJECT LOCATION Ann Arbor, Michigan
GROUND ELEVATION N/A
GROUND WATER LEVELS:
DURING DRILLING None
AFTER DRILLING None
COLLAPSE DEPTH 3' 6"

DEPTH (ft)	GRAPHIC LOG	MATERIAL DESCRIPTION	SAMPLE TYPE NUMBER	RECOVERY % (RQD)	BLOW COUNTS (N VALUE)	POCKET PEN. (tsf) UNC. STRENGTH (psf)	NATURAL MOISTURE CONTENT (%)	▲ SPT N VALUE ▲		
								20	40	60
0.0		6 inches of ASPHALT PAVEMENT								
		12 inches of gray moist crushed LIMESTONE - (FILL)	GB	100						
		6 inches of brown moist fine to medium SAND with traces of gravel and silt - (SP)	SS 1	89	5-6-8 (14)	4.0				
2.5		Brown and gray variegated moist hard CLAY with silt, traces of gravel and sand and occasional sand partings - (CL)					14			
			SS 2	100	5-8-11 (19)	4.5+				
5.0							13			

Bottom of borehole at 5.0 feet.

Boring performed 13' south of curb, 82' east of Winter Garden Court



CTI and Associates Inc

BORING NUMBER: Green B-5

PAGE 1 OF 1

CLIENT City of Ann Arbor
PROJECT NUMBER 3122040060-1
DATE STARTED 10/3/12 **COMPLETED** 10/3/12
DRILLING CONTRACTOR Stearns Drilling
DRILLING METHOD 2-1/4 inch HSA
LOGGED BY G. Geerlings **CHECKED BY** T. Marsik
NOTES Boring backfilled with auger cuttings and patched.

PROJECT NAME 2012 Ann Arbor Misc. Geotechnical Services - North Area Borings
PROJECT LOCATION Ann Arbor, Michigan
GROUND ELEVATION N/A
GROUND WATER LEVELS:
DURING DRILLING None
AFTER DRILLING None
COLLAPSE DEPTH 3' 6"

DEPTH (ft)	GRAPHIC LOG	MATERIAL DESCRIPTION	SAMPLE TYPE NUMBER	RECOVERY % (RQD)	BLOW COUNTS (N VALUE)	POCKET PEN. (tsf) UNC. STRENGTH (psf)	NATURAL MOISTURE CONTENT (%)	▲ SPT N VALUE ▲						
								20	40	60	80			
0.0		7 inches of ASPHALT PAVEMENT												
		8 inches of gray moist crushed LIMESTONE - (FILL)	GB	100										
		Brown moist loose fine to medium SAND with traces of gravel and silt - (SP)	SS 1	100	2-2-1 (3)	1.25								
2.5		Brown and gray variegated very moist stiff CLAY with silt and traces of gravel and sand - (CL)					16							
		Brown and dark gray variegated moist hard CLAY with silt, traces of gravel and sand and occasional sand partings - (CL)	SS 2	100	7-8-10 (18)	4.5+								
5.0							12							

Bottom of borehole at 5.0 feet.

Boring performed 16' north of curb, 80' east of Whisperwood Drive (west)



CTI and Associates Inc

BORING NUMBER: Green B-6

PAGE 1 OF 1

CLIENT City of Ann Arbor
PROJECT NUMBER 3122040060-1
DATE STARTED 10/3/12 **COMPLETED** 10/3/12
DRILLING CONTRACTOR Stearns Drilling
DRILLING METHOD 2-1/4 inch HSA
LOGGED BY G. Geerlings **CHECKED BY** T. Marsik
NOTES Boring backfilled with auger cuttings and patched.

PROJECT NAME Miscellaneous Geotechnical Services - North Area Borings
PROJECT LOCATION Ann Arbor, Michigan
GROUND ELEVATION N/A
GROUND WATER LEVELS:
DURING DRILLING None
AFTER DRILLING None
COLLAPSE DEPTH 3' 6"

DEPTH (ft)	GRAPHIC LOG	MATERIAL DESCRIPTION	SAMPLE TYPE NUMBER	RECOVERY % (RQD)	BLOW COUNTS (N VALUE)	POCKET PEN. (tsf) UNC. STRENGTH (psf)	NATURAL MOISTURE CONTENT (%)	▲ SPT N VALUE ▲		
								20	40	60
0.0		6 inches of ASPHALT PAVEMENT								
		12 inches of gray moist crushed LIMESTONE (FILL)	GB	100						
		6 inches of brown moist fine to medium SAND with traces of gravel and silt - (FILL)	SS 1	100	7-6-5 (11)					
2.5		Brown and gray variegated very moist very stiff CLAY with silt and traces of gravel and sand - (FILL)								
		Brown and dark brown variegated moist CLAY with silt and traces of gravel, sand and organics - (FILL)								
		Brown and gray variegated moist very stiff CLAY with silt and traces of gravel and sand - (CL)	SS 2	100	3-4-10 (14)	2.0				
5.0							16			

Bottom of borehole at 5.0 feet.

Boring performed 8' north of curb, 65' east of Whisperwood Drive (east)



CTI and Associates Inc

BORING NUMBER: Green B-7

PAGE 1 OF 1

CLIENT City of Ann Arbor
PROJECT NUMBER 3122040060-1
DATE STARTED 10/3/12 **COMPLETED** 10/3/12
DRILLING CONTRACTOR Stearns Drilling
DRILLING METHOD 2-1/4 inch HSA
LOGGED BY G. Geerlings **CHECKED BY** T. Marsik
NOTES Boring backfilled with auger cuttings and patched.

PROJECT NAME 2012 Ann Arbor Misc. Geotechnical Services - North Area Borings
PROJECT LOCATION Ann Arbor, Michigan
GROUND ELEVATION N/A
GROUND WATER LEVELS:
DURING DRILLING None
AFTER DRILLING None
COLLAPSE DEPTH 3' 6"

DEPTH (ft)	GRAPHIC LOG	MATERIAL DESCRIPTION	SAMPLE TYPE NUMBER	RECOVERY % (RQD)	BLOW COUNTS (N VALUE)	POCKET PEN. (tsf) UNC. STRENGTH (psf)	NATURAL MOISTURE CONTENT (%)	▲ SPT N VALUE ▲	
								PL	MC LL
0.0		5 inches of ASPHALT PAVEMENT						20	40 60 80
		7 inches of gray moist crushed LIMESTONE - (FILL)	GB	100				20	40 60 80
		Brown moist loose fine to medium SAND with traces of gravel and silt - (SP)	SS 1	100	4-3-5 (8)	1.5		20	40 60 80
2.5		Brown and gray variegated very moist stiff CLAY with silt and traces of gravel and sand - (CL)					20		
		Brown and gray variegated moist very stiff CLAY with silt, traces of gravel and sand and occasional silt partings - (CL)	SS 2	100	4-5-9 (14)	3.25			
5.0							19		

Bottom of borehole at 5.0 feet.

Boring performed 17' north of curb, 415' east of Whisperwood Drive (east)



CTI and Associates Inc

BORING NUMBER: Green B-8

PAGE 1 OF 1

CLIENT City of Ann Arbor
PROJECT NUMBER 3122040060-1
DATE STARTED 10/4/12 **COMPLETED** 10/4/12
DRILLING CONTRACTOR Stearns Drilling
DRILLING METHOD 2-1/4 inch HSA
LOGGED BY G. Geerlings **CHECKED BY** T. Marsik
NOTES Boring backfilled with auger cuttings and patched.

PROJECT NAME 2012 Ann Arbor Misc. Geotechnical Services - North Area Borings
PROJECT LOCATION Ann Arbor, Michigan
GROUND ELEVATION N/A
GROUND WATER LEVELS:
DURING DRILLING None
AFTER DRILLING None
COLLAPSE DEPTH 3' 6"

DEPTH (ft)	GRAPHIC LOG	MATERIAL DESCRIPTION	SAMPLE TYPE NUMBER	RECOVERY % (RQD)	BLOW COUNTS (N VALUE)	POCKET PEN. (tsf) UNC. STRENGTH (psf)	NATURAL MOISTURE CONTENT (%)	▲ SPT N VALUE ▲						
								20	40	60	80			
0.0		8 inches of ASPHALT PAVEMENT												
		10 inches of gray moist crushed LIMESTONE - (FILL)	GB	100										
		Brown moist fine to medium SAND with traces of gravel and silt - (FILL)	SS 1	100	6-6-7 (13)									
2.5		Brown and dark gray variegated moist CLAY with silt, traces of gravel and sand and occasional sand partings (FILL)												
		Gray moist crushed LIMESTONE - (FILL)	SS 2	89	4-8-5 (13)									
5.0														

Bottom of borehole at 5.0 feet.

Boring performed 12' south of curb, 23' east of Light Pole AAGR11



CTI and Associates Inc

BORING NUMBER: Green B-9

PAGE 1 OF 1

CLIENT City of Ann Arbor
PROJECT NUMBER 3122040060-1
DATE STARTED 10/4/12 **COMPLETED** 10/4/12
DRILLING CONTRACTOR Stearns Drilling
DRILLING METHOD 2-1/4 inch HSA
LOGGED BY G. Geerlings **CHECKED BY** T. Marsik
NOTES Boring backfilled with auger cuttings and patched.

PROJECT NAME 2012 Ann Arbor Misc. Geotechnical Services - North Area Borings
PROJECT LOCATION Ann Arbor, Michigan
GROUND ELEVATION N/A
GROUND WATER LEVELS:
DURING DRILLING None
AFTER DRILLING None
COLLAPSE DEPTH 3' 6"

DEPTH (ft)	GRAPHIC LOG	MATERIAL DESCRIPTION	SAMPLE TYPE NUMBER	RECOVERY % (RQD)	BLOW COUNTS (N VALUE)	POCKET PEN. (tsf) UNC. STRENGTH (psf)	NATURAL MOISTURE CONTENT (%)	▲ SPT N VALUE ▲						
								20	40	60	80			
0.0		6 inches of ASPHALT PAVEMENT												
		12 inches of gray moist crushed LIMESTONE - (FILL)	GB	100										
		6 inches of brown moist fine to medium SAND with traces of gravel and silt - (SP)	SS 1	100	8-5-3 (8)	1.25								
2.5		Brown and gray variegated moist stiff CLAY with silt and traces of gravel and sand - (CL)					14							
		Brown and dark gray variegated moist hard CLAY with silt, traces of gravel and sand and occasional sand partings - (CL)	SS 2	100	4-8-12 (20)	4.5+								
5.0							12							

Bottom of borehole at 5.0 feet.

Boring performed 11' south of curb, 7' east of Light Pole AAGR13



Professional Service Industries, Inc.
 45749 Helm Street
 Plymouth, MI 48170
 Telephone: (734) 453-7900
 Fax: (734) 453-0724

LOG OF BORING B-16

Sheet 1 of 1

PSI Job No.: 0381411 2 (H)
 Project: Miscellaneous Geotechnical Services
 Location: Packard Street
 Between Anderson Ave and Eisenhower Parkway
 City of Ann Arbor, Michigan

Drilling Method: 2.25" Solid Stem Auger
 Sampling Method: 2" SS
 Hammer Type: Automatic
 Boring Location: Northbound Outside Lane
 Approx 5' West of Curb

WATER LEVELS
 ▽ While Drilling None feet
 ▽ Upon Completion None feet
 ▽ None feet

Elevation (feet)	Depth (feet)	Graphic Log	Sample Type	Sample No.	Recovery (inches)	MATERIAL DESCRIPTION	USCS Classification	SPT Blows per 6-inch (SS)	Moisture, %	STANDARD PENETRATION TEST DATA		Additional Remarks
										N in blows/ft	⊙	
	0			1	6	5.8" ASPHALT PAVEMENT; Intact core recovered						
				2	12	12" SAND BASE, fine to coarse, with gravel and silt, brown and grayish brown, moist						
				3	16	SAND, fine to coarse, with gravel and silt, trace seams of silty clayey sand, brown and grayish brown, moist, medium dense	SP-SM	14, 12, 18 N=30	5	×	⊙	
				4	14	GRAVELLY SAND, trace silt, brown, moist, dense	SP	12, 15, 19 N=34	3	×	⊙	
	5					End of Boring						

Completion Depth: 5.5 ft
 Date Boring Started: 11/2/11
 Date Boring Completed: 11/2/11
 Logged By: JDH
 Drilling Contractor: PSI - Mike Dubnicki

Sample Types:
 Auger Cutting
 Split-Spoon
 Rock Core
 Shelby Tube
 Hand Auger
 Calif. Sampler
 Texas Cone

Latitude:
 Longitude:
 Drill Rig: CME 75
 Remarks: Borehole backfilled with auger cuttings and pavement surface patched upon completion

The stratification lines represent approximate boundaries. The transition may be gradual.



Professional Service Industries, Inc.
 45749 Helm Street
 Plymouth, MI 48170
 Telephone: (734) 453-7900
 Fax: (734) 453-0724

LOG OF BORING B-17

Sheet 1 of 1

PSI Job No.: 0381411-2 (H)
 Project: Miscellaneous Geotechnical Services
 Location: Packard Street
 Between Anderson Ave and Eisenhower Parkway
 City of Ann Arbor, Michigan

Drilling Method: 2.25" Solid Stem Auger
 Sampling Method: 2" SS
 Hammer Type: Automatic
 Boring Location: Northbound Inside Lane
 Approx 18' West of Curb

WATER LEVELS
 ▽ White Drilling None feet
 ▽ Upon Completion None feet
 ▽ None feet

Elevation (feet)	Depth, (feet)	Graphic Log	Sample Type	Sample No.	Recovery (inches)	Station: N/A Offset: N/A	MATERIAL DESCRIPTION	USCS Classification	SPT Blows per 6-inch (SS)	Moisture, %	STANDARD PENETRATION TEST DATA		Additional Remarks
											N in blows/ft @	Moisture	
											STRENGTH, tsf		
											▲ Qu	⊕ Qp	
0				1	6		5.7" ASPHALT PAVEMENT; Intact core recovered						
				2	12		12" SILTY SAND BASE, fine to coarse, with gravel and silty clayey sand, reddish brown, moist						
				3	17		SILTY SAND, fine, trace gravel and seams of silty clayey sand, light brown to yellowish brown, moist, medium dense	SM	11,10,7 N=17	11			
				4	18		SILTY CLAY, brown, moist, stiff	CL	5,6,8 N=14	16			
							End of Boring						

Completion Depth: 5.5 ft
 Date Boring Started: 11/2/11
 Date Boring Completed: 11/2/11
 Logged By: JDH
 Drilling Contractor: PSI - Mike Dubnicki

Sample Types:
 Auger Cutting
 Split-Spoon
 Rock Core
 Shelby Tube
 Hand Auger
 Calif. Sampler
 Texas Cone

Latitude:
 Longitude:
 Drill Rig: CME 75
 Remarks: Borehole backfilled with auger cuttings and pavement surface patched upon completion

The stratification lines represent approximate boundaries. The transition may be gradual.



Professional Service Industries, Inc.
 45749 Helm Street
 Plymouth, MI 48170
 Telephone: (734) 453-7900
 Fax: (734) 453-0724

LOG OF BORING B-18

Sheet 1 of 1

PSI Job No.: 0381411-2 (H)
 Project: Miscellaneous Geotechnical Services
 Location: Packard Street
 Between Anderson Ave and Eisenhower Parkway
 City of Ann Arbor, Michigan

Drilling Method: 2.25" Solid Stem Auger
 Sampling Method: 2" SS
 Hammer Type: Automatic
 Boring Location: Southbound Inside Lane
 Approx 18' East of Curb

WATER LEVELS
 ▽ While Drilling None feet
 ▽ Upon Completion None feet
 ▽ None feet

Elevation (feet)	Depth (feet)	Graphic Log	Sample Type	Sample No.	Recovery (inches)	MATERIAL DESCRIPTION	USCS Classification	SPT Blows per 6-inch (SS)	Moisture, %	STANDARD PENETRATION TEST DATA		Additional Remarks
										N in blows/ft	⊙	
	0			1	6	6.2" ASPHALT PAVEMENT; Intact core recovered						
				2	12	6" SILTY SAND BASE, fine to coarse, with gravel, brown and grayish brown, moist						
				3	16	SILTY CLAY, with organics and seams of fine sand, dark gray and brown, moist	ML	3,3,4 N=7	15			
				4	16	SANDY CLAY, trace gravel and organics, brown, reddish brown and dark gray, moist	CL	5,8,10 N=18	18			Qp = 3.0 tsf
	5					End of Boring						

Completion Depth: 5.5 ft
 Date Boring Started: 11/1/11
 Date Boring Completed: 11/1/11
 Logged By: JDH
 Drilling Contractor: PSI - Mike Dubnicki

Sample Types:
 Auger Cutting
 Split-Spoon
 Rock Core
 Shelby Tube
 Hand Auger
 Calif. Sampler
 Texas Cone

Latitude:
 Longitude:
 Drill Rig: CME 75
 Remarks: Borehole backfilled with auger cuttings and pavement surface patched upon completion

The stratification lines represent approximate boundaries. The transition may be gradual.



Professional Service Industries, Inc.
 45749 Helm Street
 Plymouth, MI 48170
 Telephone: (734) 453-7900
 Fax: (734) 453-0724

LOG OF BORING B-19

Sheet 1 of 1

PSI Job No.: 0381411-2 (H)
 Project: Miscellaneous Geotechnical Services
 Location: Packard Street
 Between Anderson Ave and Eisenhower Parkway
 City of Ann Arbor, Michigan

Drilling Method: 2.25" Solid Stem Auger
 Sampling Method: 2" SS
 Hammer Type: Automatic
 Boring Location: Southbound Outside Lane
 Approx 4' East of Curb

WATER LEVELS	
▽ While Drilling	None feet
▽ Upon Completion	None feet
▽	feet

Elevation (feet)	Depth (feet)	Graphic Log	Sample Type	Sample No.	Recovery (inches)	MATERIAL DESCRIPTION	USCS Classification	SPT Blows per 6-inch (SS)	Moisture, %	STANDARD PENETRATION TEST DATA		Additional Remarks
										N in blows/ft	Moisture	
										STRENGTH, tsf		
										▲ Qu	⊕ Qp	
0				1	14	14.2" ASPHALT PAVEMENT; Intact core recovered						
				2	4	11" SILTY CLAYEY SAND BASE, fine to medium, trace gravel, dark reddish brown, very moist						
				3	18	SILTY CLAY, trace sand, reddish brown, very moist, stiff	CL	5,4,5 N=9	21			Qp = 2.0 tsf
				4	18	SILTY CLAY, trace sand, mottled orange brown and grayish brown, very moist, very stiff	CL	4,5,5 N=10	23			Qp = 2.5 tsf
						End of Boring						

Completion Depth: 5.5 ft
 Date Boring Started: 11/1/11
 Date Boring Completed: 11/1/11
 Logged By: JDH
 Drilling Contractor: PSI - Mike Dubnicki

Sample Types:
 Auger Cutting
 Split-Spoon
 Rock Core
 Sheiby Tube
 Hand Auger
 Calif. Sampler
 Texas Cone

Latitude:
 Longitude:
 Drill Rig: CME 75
 Remarks: Borehole backfilled with auger cuttings and pavement surface patched upon completion

The stratification lines represent approximate boundaries. The transition may be gradual.

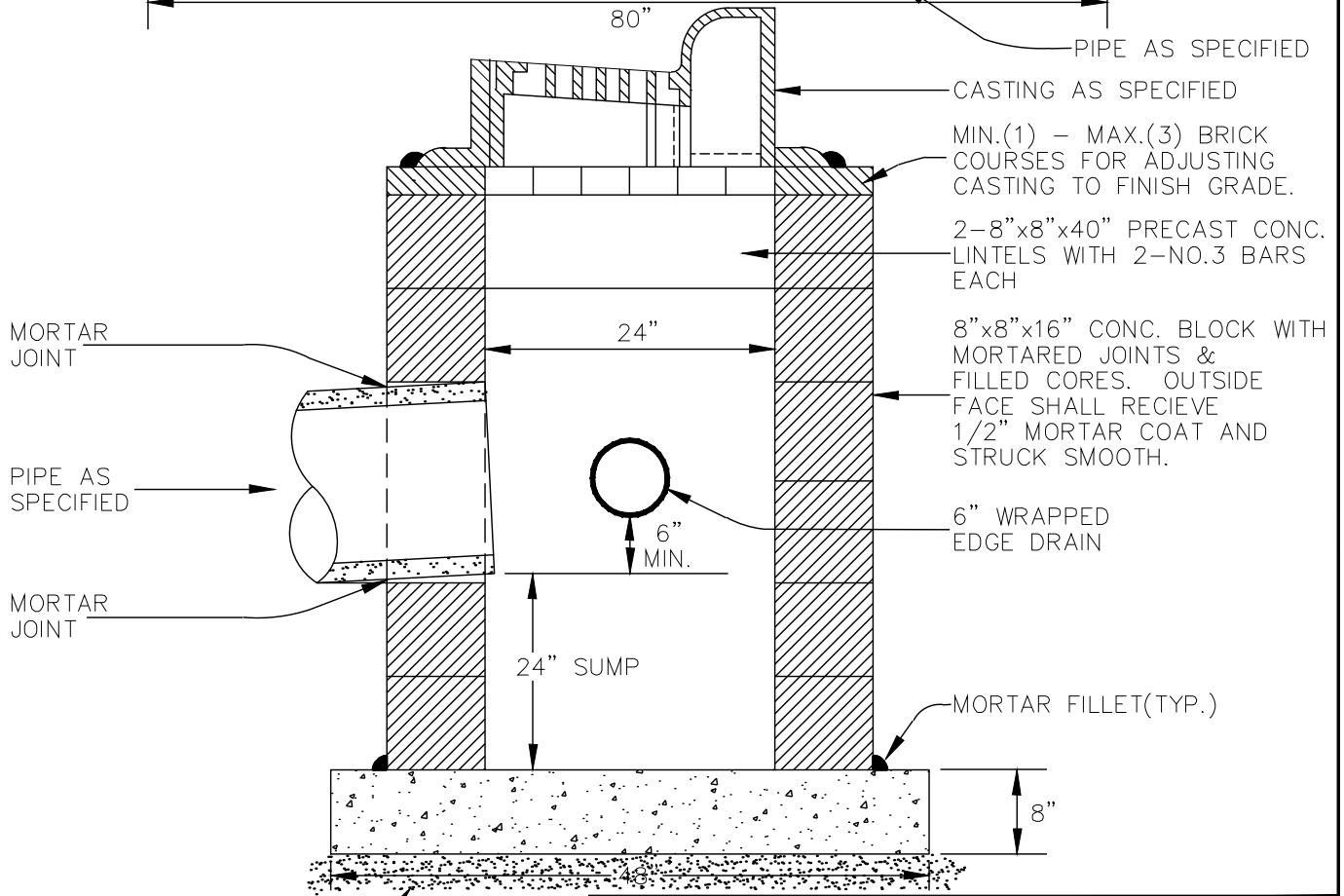
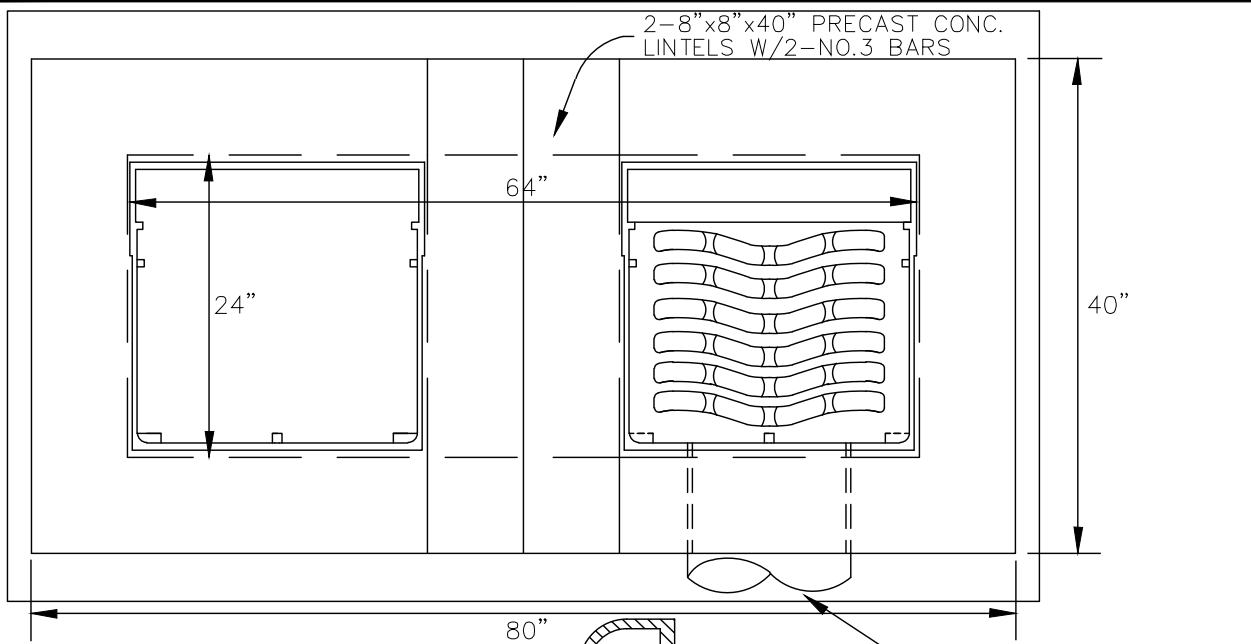

MIN. 4" 21AA STONE BEDDING AND BACKFILL UNDER BASE AND TO FIRST PIPE JOINT.

NOTE: FRONT EDGE OF INLET CASTINGS SHALL BE FLUSH WITH FRONT EDGE OF GUTTER (EDGE-OF-METAL)

CONC. BLOCK REVISED		1	NCF	CSS	1-31-94
REVISIONS		REV. NO.	DR.BY	CH. BY	DATE
PUBLIC SERVICES DEPARTMENT					
CITY OF ANN ARBOR					
DOUBLE INLET STRUCTURE					
DR. BY	DF/DCO	CH. BY	CSS/DF	DRAWING NO.	
SCALE	NONE	DATE	11-6-92	SD-S-11	
INCH	0  1			SHEET NO. _____ OF _____	

MICHIGAN
DEPARTMENT OF TRANSPORTATION

SPECIAL PROVISION
FOR
ACCEPTANCE OF HOT MIX ASPHALT MIXTURE ON LOCAL AGENCY PROJECTS

CFS:KPK

1 of 7

APPR:CJB:JWB:10-15-15
FHWA:APPR:11-02-15

a. Description. This special provision provides sampling and testing requirements for local agency projects using the roller method and the nuclear density gauge testing. Provide the hot mix asphalt (HMA) mixture in accordance with the requirements of the standard specifications, except where modified herein.

b. Materials. Provide aggregates, mineral filler (if required), and asphalt binder to produce a mixture proportioned within the master gradation limits shown in the contract, and meeting the uniformity tolerance limits in Table 1.

Table 1: Uniformity Tolerance Limits for HMA Mixtures

Parameter		Top and Leveling Course		Base Course		
Number	Description	Range 1 (a)	Range 2	Range 1 (a)	Range 2	
1	% Binder Content	-0.30 to +0.40	±0.50	-0.30 to +0.40	±0.50	
2	% Passing	# 8 and Larger Sieves	±5.0	±8.0	±7.0	±9.0
		# 30 Sieve	±4.0	±6.0	±6.0	±9.0
		# 200 Sieve	±1.0	±2.0	±2.0	±3.0
3	Crushed Particle Content (b)	Below 10%	Below 15%	Below 10%	Below 15%	
<p>a. This range allows for normal mixture and testing variations. The mixture must be proportioned to test as closely as possible to the Job-Mix-Formula (JMF).</p> <p>b. Deviation from JMF.</p>						

Parameter number 2 as shown in Table 1 is aggregate gradation. Each sieve will be evaluated on one of the three gradation tolerance categories. If more than one sieve is exceeding Range 1 or Range 2 tolerances, only the one with the largest exceedance will be counted as the gradation parameter.

The master gradation should be maintained throughout production; however, price adjustments will be based on Table 1. Aggregates which are to be used in plant-mixed HMA mixtures must not contain topsoil, clay, or loam.

c. Construction. Submit a Mix Design and a JMF to the Engineer. Do not begin production and placement of the HMA until receipt of the Engineer's approval of the JMF. Maintain the binder content, aggregate gradation, and the crushed particle content of the HMA mixture within the Range 1 uniformity tolerance limits in Table 1. For all mixtures, field regress air void content to 3.5 percent with liquid asphalt cement unless specified otherwise on HMA application estimate.

Ensure all persons performing Quality Control (QC) and Quality Assurance (QA) HMA field sampling are "Local Agency HMA Sampling Qualified" samplers. At the Pre-Production or Pre-Construction meeting, the Engineer will determine the method of sampling to be used. Ensure all sampling is done in accordance with *MTM 313 (Sampling HMA Paving Mixtures)* or *MTM 324 (Sampling HMA Paving Mixtures Behind the Paver)*. Samples are to be taken from separate hauling loads.

For production/mainline type paving, obtain a minimum of two samples, each being 20,000 grams, each day of production, for each mix type. The Engineer will sample and maintain possession of the sample. Sampling from the paver hopper is prohibited. Each sample will be divided into two 10,000 gram parts with one part being for initial testing and the other part being held for possible dispute resolution testing. Obtain a minimum of three samples for each mix type regardless of the number of days of production.

Obtain samples that are representative of the day's paving. Sample collection is to be spaced throughout the planned tonnage. One sample will be obtained in the first half of the tonnage and the second sample will be obtained in the second half of the tonnage. If planned paving is reduced or suspended, when paving resumes, the remaining sampling must be representative of the original intended sampling timing.

Ensure all persons performing testing are Bit Level One certified or Bit QA/QC Technician certified.

Ensure daily test samples are obtained, except, if the first test results show that the HMA mixture is in specification, the Engineer has the option of not testing additional samples from that day.

At the Pre-Production or Pre-Construction meeting, the Engineer and Contractor will collectively determine the test method for measuring asphalt content (AC) using *MTM 319 (Determination of Asphalt Content from Asphalt Paving Mixtures by the Ignition Method)* or *MTM 325 (Quantitative Extraction of Bitumen from HMA Paving Mixtures)*. Back calculation will not be allowed for determining asphalt content.

Ensure all labs performing local agency acceptance testing are qualified labs per the *HMA Production Manual* and participate in the MDOT round robin process, or they must be *AASHTO Materials Reference Laboratory (AMRL)* accredited for *AASHTO T 30* or *T 27*, and *AASHTO T 164* or *T 308*. Ensure on non-National Highway System (NHS) routes, Contractor labs are made available, and may be used, but they must be qualified labs as previously stated. Contractor labs may not be used on NHS routes. Material acceptance testing will be completed by the Engineer within 14 calendar days, except holidays and Sundays, for projects with less than 5,000 tons (plan quantity) of HMA and within 7 calendar days, except holidays and Sundays, for projects with 5,000 tons (plan quantity) or more of HMA, after the Engineer has obtained the samples. QA test results will be provided to the Contractor after the Engineer receives the QC test results. Failure on the part of the Engineer or the laboratory to provide Quality Assurance test results within the specified time frame does not relieve the Contractor of their responsibility to provide an asphalt mix within specifications.

The correlation procedure for ignition oven will be established as follows. Asphalt binder content based on ignition method from *MTM 319*. Gradation (*ASTM D 5444*) and Crushed particle content (*MTM 117*) based on aggregate from *MTM 319*. The incineration temperature will be established at the Pre-Production Meeting. The Contractor will provide a laboratory mixture sample to the

acceptance laboratory to establish the correction factor for each mix. Ensure this sample is provided to the Engineer a minimum of 14 calendar days prior to production.

For production/mainline type paving, the mixture may be accepted by visual inspection up to a quantity of 500 tons per mixture type, per project (not per day). For non-production type paving defined as driveways, approaches, and patching, visual inspection may be allowed regardless of the tonnage.

The mixture will be considered out-of-specification, as determined by the acceptance tests, if for any one mixture, two consecutive tests per parameter, (for Parameter 2, two consecutive aggregate gradations on one sieve) are outside Range 1 or Range 2 tolerance limits. If a parameter is outside of Range 1 tolerance limits and the second consecutive test shows that the parameter is outside of Range 2, then it will be considered to be a Range 1 out-of-specification. Consecutive refers to the production order and not necessarily the testing order. Out-of-specification mixtures are subject to a price adjustment per the Measurement and Payment section of this special provision.

Contractor operations will be suspended when the mixture is determined to be out-of-specification, but contract time will continue to run. The Engineer may issue a Notice of Non-Compliance with Contract Requirements (Form 1165), if the Contractor has not suspended operations and taken corrective action. Submit a revised JMF or proposed alterations to the plant and/or materials to achieve the JMF to the Engineer. Effects on the Aggregate Wear Index (AWI) and mix design properties will be taken into consideration. Production and placement cannot resume until receipt of the Engineer's approval to proceed.

Pavement in-place density will be measured using one of two approved methods. The method used for measuring in-place density will be agreed upon at a pre-production or pre-construction meeting.

Pavement in-place density tests will be completed by the Engineer during paving operations and prior to traffic staging changes. Pavement in-place density acceptance testing will be completed by the Engineer prior to paving of subsequent lifts and being open to traffic.

Option 1 – Direct Density Method

Use of a nuclear density gauge requires measuring the pavement density using the Gmm from the JMF for the density control target. The required in-place density of the HMA mixture must be 92.0 to 98.0 percent of the density control target. Nuclear density testing and frequency will be in accordance with the *MDOT Density Testing and Inspection Manual*.

Option 2 – Roller Method

The Engineer may use the Roller Method with a nuclear or non-nuclear density gauge to document achieving optimal density as discussed below.

Use of the density gauge requires establishing a rolling pattern that will achieve the required in-place density. The Engineer will measure pavement density with a density gauge using the Gmm from the JMF for the density control target.

Use of the Roller Method requires developing and establishing density frequency curves, and meeting the requirements of Table 2. A density frequency curve is defined as the measurement

and documentation of each pass of the finished roller until the in-place density results indicate a decrease in value. The previous recording will be deemed the optimal density. The Contractor is responsible for establishing and documenting an initial or QC rolling pattern that achieves the optimal in-place density. When the density frequency curve is used, the Engineer will run and document the density frequency curve for each half day of production to determine the number of passes to achieve the maximum density. Table 5, located at the end of this special provision, can be used as an aid in developing the density frequency curve. The Engineer will perform density tests using an approved nuclear or non-nuclear gauge per the manufacturer's recommended procedures.

Table 2: Minimum Number of Rollers Recommended Based on Placement Rate

Average Laydown Rate, Square Yards per Hour	Number of Rollers Required (a)	
	Compaction	Finish
Less than 600	1	1 (b)
601 - 1200	1	1
1201 - 2400	2	1
2401 - 3600	3	1
3601 and More	4	1

a. Number of rollers may increase based on density frequency curve.
b. The compaction roller may be used as the finish roller also.

After placement, roll the HMA mixture as soon after placement as the roller is able to bear without undue displacement or cracking. Start rolling longitudinally at the sides of the lanes and proceed toward the center of the pavement, overlapping on successive trips by at least half the width of the drum. Ensure each required roller is 8 tons minimum in weight unless otherwise approved by the Engineer.

Ensure the initial breakdown roller is capable of vibratory compaction and is a maximum of 500 feet behind the paving operations. The maximum allowable speed of each roller is 3 miles per hour (mph) or 4.5 feet per second. Ensure all compaction rollers complete a minimum of two complete rolling cycles prior to the mat temperature cooling to 180 degrees Fahrenheit (F). Continue finish rolling until all roller marks are eliminated and no further compaction is possible. The Engineer will verify and document that the roller pattern has been adhered to. The Engineer can stop production when the roller pattern is not adhered to.

d. Measurement and Payment. The completed work, as described, will be measured and paid for using applicable pay items as described in subsection 501.04 of the Standard Specifications for Construction, or the contract, except as modified below.

Base Price. Price established by the Department to be used in calculating incentives and adjustments to pay items and shown in the contract.

If acceptance tests, as described in section c. of this special provision, show that a Table 1 mixture parameter exceeds the Range 1, but not the Range 2, tolerance limits, that mixture parameter will be subject to a 10 percent penalty. The 10 percent penalty will be assessed based on the acceptance tests only unless the Contractor requests that the 10,000 gram sample part retained

for possible dispute resolution testing be tested. The Contractor has 4 calendar days from receipt of the acceptance test results to notify the Engineer, in writing, that dispute resolution testing is requested. The Contractors QC test results for the corresponding QA test results must result in an overall payment greater than QA test results otherwise the QA tests will not be allowed to be disputed. The Engineer has 4 calendar days to send the dispute resolution sample to the lab once dispute resolution testing is requested. The dispute resolution sample will be sent to an independent lab selected by the Local Agency, and the resultant dispute test results will be used to determine the penalty per parameter, if any. Ensure the independent lab is a MDOT QA/QC qualified lab or an AMRL HMA qualified lab. The independent lab must not have conflicts of interest with the Contractor or Local Agency. If the dispute testing results show that the mixture parameter is out-of-specification, the Contractor will pay for the cost of the dispute resolution testing and the contract base price for the material will be adjusted, based on all test result parameters from the dispute tests, as shown in Table 3 and Table 4. If the dispute test results do not confirm the mixture parameter is out-of-specification, then the Local Agency will pay for the cost of the dispute resolution testing and no price adjustment is required.

If acceptance tests, as described in section c. of this special provision, show that a Table 1 mixture parameter exceeds the Range 2 tolerance limits, the 10,000 gram sample part retained for possible dispute resolution testing will be sent, within 4 calendar days, to the MDOT Central Laboratory for further testing. The MDOT Central Laboratory's test results will be used to determine the penalty per mixture parameter, if any. If the MDOT Central Laboratory's results do not confirm the mixture parameter is out-of-specification, then no price adjustment is required. If the MDOT Central Laboratory's results show that the mixture is out-of-specification and the Engineer approves leaving the out-of-specification mixture in place, the contract base price for the material will be adjusted, based on all parameters, as shown in Table 3 and Table 4.

In the case that the Contractor disputes the results of the test of the second sample obtained for a particular day of production, the test turn-around time frames given would apply to the second test and there would be no time frame on the first test.

The laboratory (MDOT Central Laboratory or independent lab) will complete all Dispute Resolution testing and return test results to the Engineer, who will provide them to the Contractor, within 13 calendar days upon receiving the Dispute Resolution samples.

In all cases, when penalties are assessed, the penalty applies to each parameter, up to two parameters, that is out of specification.

Table 3: Penalty Per Parameter

Mixture Parameter out-of-Specification per Acceptance Tests	Mixture Parameter out-of-Specification per Dispute Resolution Test Lab	Price Adjustment per Parameter
NO	N/A	None
YES	NO	None
	YES	Outside Range 1 but not Range 2: decrease by 10%
		Outside Range 2: decrease by 25%

The quantity of material receiving a price adjustment is defined as the material produced from the time the first out-of-specification sample was taken until the time the sample leading to the first in-specification test was taken.

Each parameter of Table 1 is evaluated with the total price adjustment applied to the contract base price based on a sum of the two parameter penalties resulting in the highest total price adjustment as per Table 4. For example, if three parameters are out-of-specification, with two parameters outside Range 1 of Table 1 tolerance limits, but within Range 2 of Table 1 limits and one parameter outside of Range 2 of Table 1 tolerance limits and the Engineer approves leaving the mixture in place, the total price adjustment for that quantity of material is 35 percent.

Table 4: Calculating Total Price Adjustment

Cost Adjustment as a Sum of the Two Highest Parameter Penalties		
Number of Parameters Out-of-Specification	Range(s) Outside of Tolerance Limits of Table 1 per Parameter	Total Price Adjustment
One	Range 1	10%
	Range 2	25%
Two	Range 1 & Range 1	20%
	Range 1 & Range 2	35%
	Range 2 & Range 2	50%
Three	Range 1, Range 1 & Range 1	20%
	Range 1, Range 1 & Range 2	35%
	Range 1, Range 2 & Range 2	50%
	Range 2, Range 2 & Range 2	50%

Table 5: Density Frequency Curve Development

Tested by: _____ Date/Time: _____

Route/Location:		Air Temp:
Control Section/Job Number:		Weather:
Mix Type:	Tonnage:	Gauge:
Producer:	Depth:	Gmm:

Roller #1 Type:

Pass No.	Density	Temperature	Comments
1			
2			
3			
4			
5			
6			
7			
8			
Optimum			

Roller #2 Type:

Pass No.	Density	Temperature	Comments
1			
2			
3			
4			
5			
6			
7			
8			
Optimum			

Roller #3 Type:

Pass No.	Density	Temperature	Comments
1			
2			
3			
4			
5			
6			
7			
8			
Optimum			

Summary: _____

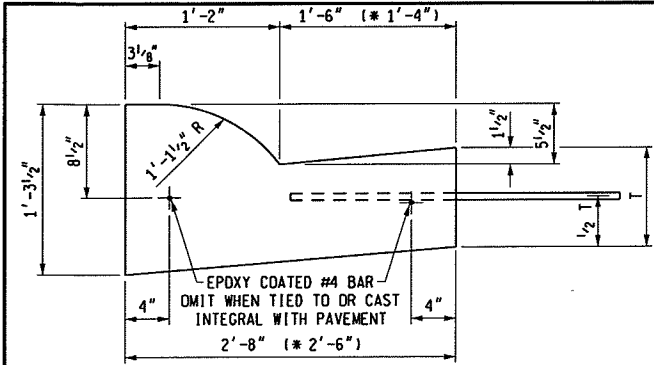

(* GUTTER PAN WIDTH MAY BE REDUCED WHEN APPROVED BY THE ENGINEER)

DETAIL	DIMENSION		LANE TIES	CONCRETE CYD / LFT	CONCRETE CYD / LFT
	T				
B1	9"		AS SHOWN	0.0900	(* 0.0855)
B2	9"		OMITTED	0.0900	(* 0.0855)
B3	10"		AS SHOWN	0.0941	(* 0.0894)

B

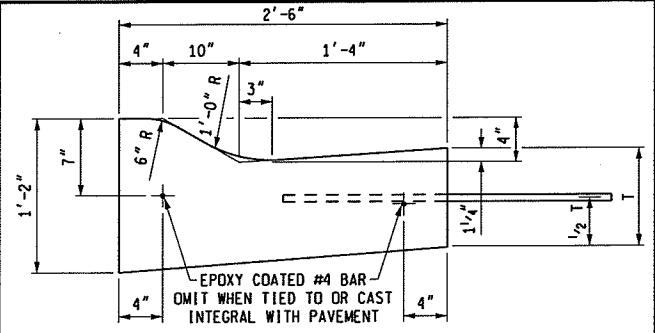

DETAIL	DIMENSION		LANE TIES	CONCRETE CYD / LFT
	T			
D1	9"		AS SHOWN	0.0788
D2	9"		OMITTED	0.0788
D3	10"		AS SHOWN	0.0826

D

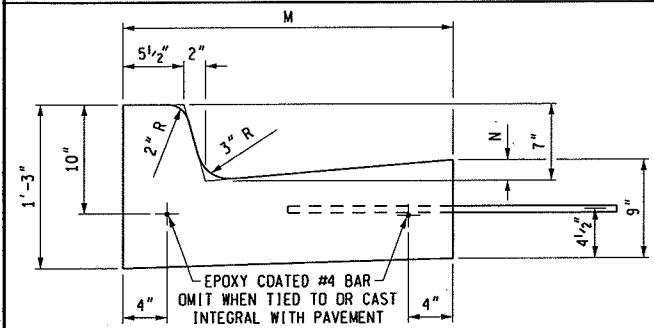

DETAIL	DIMENSION		LANE TIES	CONCRETE CYD / LFT
	M	N		
C1	1'-6"	7/8"	AS SHOWN	0.0506
C2	1'-6"	7/8"	OMITTED	0.0506
C3	2'-0"	1 3/8"	AS SHOWN	0.0632
C4	2'-0"	1 3/8"	OMITTED	0.0632
C5	2'-6"	1 1/8"	AS SHOWN	0.0757
C6	2'-6"	1 7/8"	OMITTED	0.0757

C

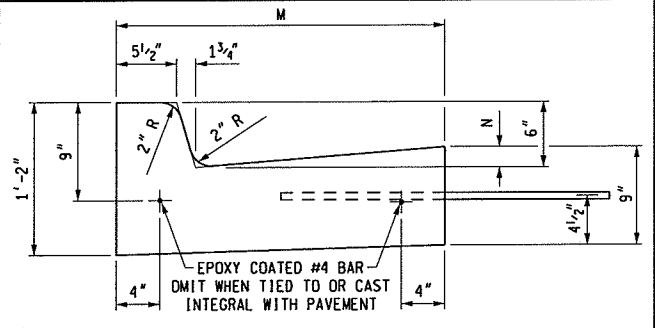

DETAIL	DIMENSION		LANE TIES	CONCRETE CYD / LFT
	M	N		
F1	1'-6"	7/8"	AS SHOWN	0.0484
F2	1'-6"	7/8"	OMITTED	0.0484
F3	2'-0"	1 3/8"	AS SHOWN	0.0610
F4	2'-0"	1 3/8"	OMITTED	0.0610
F5	2'-6"	1 1/8"	AS SHOWN	0.0737
F6	2'-6"	1 7/8"	OMITTED	0.0737

F

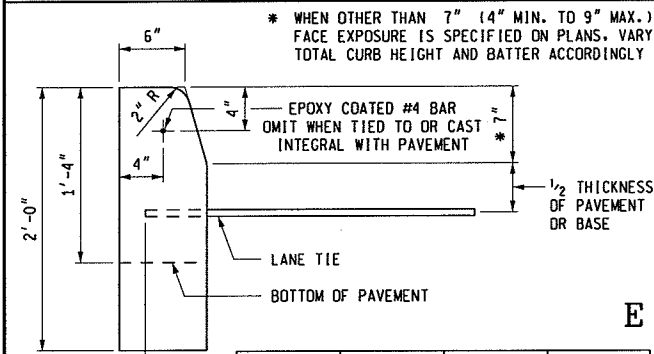

DETAIL	CURB HEIGHT	LANE TIES	CONCRETE CYD / LFT
E1	1'-4"	AS SHOWN	0.0310
E2	1'-4"	OMITTED	0.0310
E4	2'-0"	OMITTED	0.0477

E



PREPARED BY
DESIGN DIVISION
DRAWN BY: B.L.T.
CHECKED BY: W.K.P.

DEPARTMENT DIRECTOR
Kirk T. Steudle
APPROVED BY: *Randy V. ...*
DIRECTOR, BUREAU OF FIELD SERVICES
APPROVED BY: *Mark A. Van ...*
DIRECTOR, BUREAU OF HIGHWAY DEVELOPMENT

MICHIGAN DEPARTMENT OF TRANSPORTATION
BUREAU OF HIGHWAY DEVELOPMENT STANDARD PLAN FOR

CONCRETE CURB AND
CONCRETE CURB & GUTTER

9-30-2014 F.H.W.A. APPROVAL	2-6-2014 PLAN DATE	R-30-G	SHEET 1 OF 2
--------------------------------	-----------------------	--------	-----------------

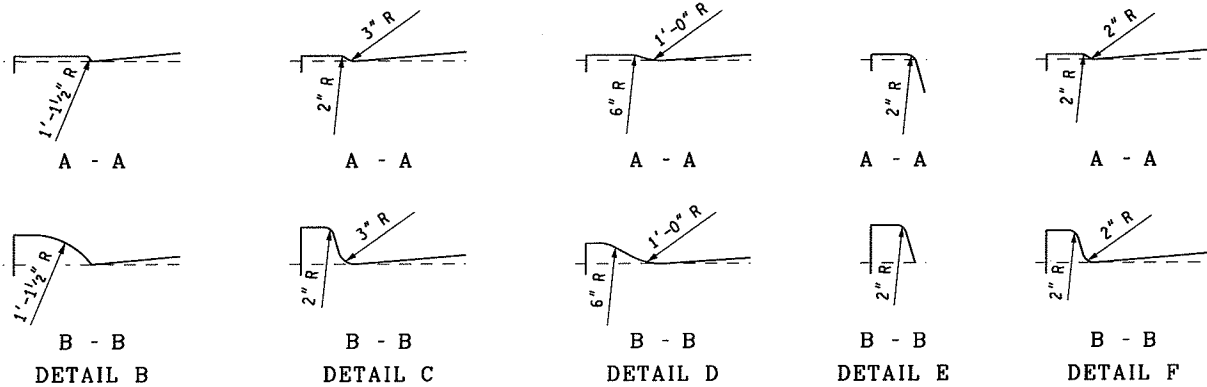
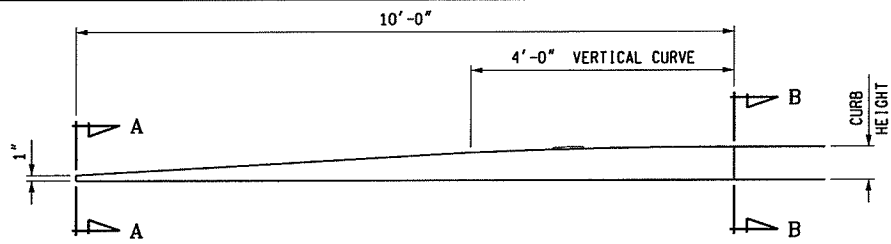

CONCRETE CURB, CURB AND GUTTER ENDINGS

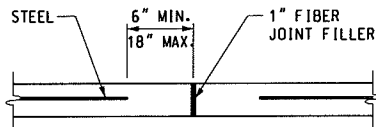

1" FIBER JOINT FILLER

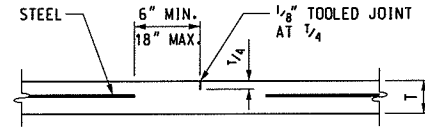

CONTRACTION JOINT

NOTES:

CURB AND GUTTER RADII SHALL BE DIMENSIONED TO THE FRONT EDGE OF THE GUTTER PAN OR EDGE OF PAVEMENT.

CONCRETE CURB AND GUTTER ENDINGS WILL BE PAID FOR IN LINEAR FEET OF THE ADJACENT CURB DETAIL.

JOINTS SHALL BE PLACED AT RIGHT ANGLES TO THE EDGE OF CONCRETE CURB AND GUTTER.

JOINTS DETAILED ON THE PLANS SHALL SUPERSEDE THOSE SPECIFIED ON THIS STANDARD PLAN.

BOTTOM SLOPE OF CURB AND GUTTER STRUCTURE MAY BE THE SAME SLOPE AS BOTTOM OF PAVEMENT. BACK OF CURB AND VERTICAL EDGE OF GUTTER PAN MAY HAVE A MAXIMUM 1/2" BATTER TO FACILITATE FORMING.

WHEN CURB AND GUTTER IS CAST INTEGRALLY, SEE CURRENT STANDARD PLAN R-31-SERIES.

ALL JOINTS FOR CURB OR CURB AND GUTTER ARE INCLUDED IN THE PAY ITEM FOR THE CURB OR CURB AND GUTTER.

JOINTS IN CURB OR CURB AND GUTTER NOT TIED TO CONCRETE PAVEMENT; ADJACENT TO CONCRETE BASE COURSE; OR ADJACENT TO HMA PAVEMENT:

- A. PLACE 1" FIBER JOINT FILLER AT 400' MAXIMUM INTERVALS.
- B. PLACE 1" FIBER JOINT FILLER AT SPRING POINTS OF INTERSECTING STREETS.
- C. PLACE 1/2" ISOLATION JOINT AT CATCH BASINS PER STANDARD PLAN R-37-SERIES.
- D. PLACE CONTRACTION JOINTS AT 40' MAXIMUM INTERVALS.

JOINTS IN CURB OR CURB AND GUTTER TIED TO JOINTED PAVEMENT

- A. PLACE 1" FIBER JOINT FILLER OPPOSITE ALL TRANSVERSE EXPANSION JOINTS IN PAVEMENT.
- B. PLACE 1/2" ISOLATION JOINT AT CATCH BASINS PER STANDARD PLAN R-37-SERIES.
- C. PLACE CONTRACTION JOINTS OPPOSITE ALL TRANSVERSE CONTRACTION JOINTS IN PAVEMENT.
- D. A SYMBOL (B) JOINT SHALL BE PLACED BETWEEN CURB OR CURB AND GUTTER AND ADJACENT CONCRETE PAVEMENT AS SPECIFIED ON STANDARD PLAN R-41-SERIES.

MICHIGAN DEPARTMENT OF TRANSPORTATION
BUREAU OF HIGHWAY DEVELOPMENT STANDARD PLAN FOR

**CONCRETE CURB AND
CONCRETE CURB & GUTTER**

9-30-2014
F.H.W.A. APPROVAL

2-6-2014
PLAN DATE

R-30-G

SHEET
2 OF 2



CITY OF ANN ARBOR PROJECT MANAGEMENT

STREET RESURFACING - 2016

ITB No. 4422 FILE No. 2016004

NOTES:

FOR PROTECTION OF UNDERGROUND UTILITIES AND IN CONFORMANCE WITH PUBLIC ACT 174 OF 2013, THE CONTRACTOR SHALL CALL 811 OR 1-800-482-7171 A MINIMUM OF THREE FULL WORKING DAYS, EXCLUDING SATURDAYS, SUNDAYS, AND HOLIDAYS, PRIOR TO BEGINNING EACH EXCAVATION IN AREAS WHERE PUBLIC UTILITIES HAVE NOT BEEN PREVIOUSLY LOCATED. MEMBERS WILL THUS BE ROUTINELY NOTIFIED. THIS DOES NOT RELIEVE THE CONTRACTOR OF THE RESPONSIBILITY OF NOTIFYING UTILITY OWNERS WHO MAY NOT BE A PART OF THE "MISS DIG" ALERT SYSTEM.

THE UNDERGROUND LOCATIONS SHOWN FOR NATURAL GAS, TELEPHONE, ELECTRICAL POWER, CABLE TV AND FIBER OPTIC LINES ARE APPROXIMATE. THE CITY OF ANN ARBOR ASSUMES NO RESPONSIBILITY FOR THEIR ACCURATE REPRESENTATION IN THIS DRAWING. MISS DIG MUST BE CONTACTED PRIOR TO CONSTRUCTION TO LOCATE THESE UTILITIES.

THE CONSTRUCTION COVERED BY THESE PLANS SHALL CONFORM TO THE 1994 EDITION OF THE CITY OF ANN ARBOR PUBLIC SERVICES DEPARTMENT STANDARD SPECIFICATIONS, ITS DETAILS, WHICH ARE INCLUDED BY REFERENCE, AND THIS PROJECT'S CONTRACT DOCUMENTS. THE OMISSION OF ANY CURRENT STANDARD DETAIL DOES NOT RELIEVE THE CONTRACTOR FROM THIS REQUIREMENT.

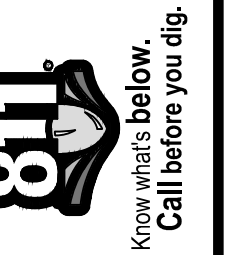

SHEET INDEX

SHEET NO.	TITLE	MAP INDEX NO. (THIS SHEET)
1	COVER SHEET	
2-5	Depot Street	1
6-13	Pauline Boulevard	2
14-24	Dexter Avenue	3
25-32	Dhu Varren Road	4
33-43	Green Road	5
44-54	Pontiac Trail	6
55-66	Huron River Drive	7
67-71	Maiden Lane	8
72-83	Eisenhower Parkway & Packard Road	9
84-86	Tacoma Circle	10
87-89	Birch Hollow Drive	11
90-91	North Baylis Drive	12
92-93	Catalpa Circle & Pebble Creek Road	13
94-95	Brentwood, Quail Hollow, Sussex & Wexford Courts	14
96-97	Beaconsfield Drive, Page Avenue & Ticknor Court	15
98	Traffic Calming Details	

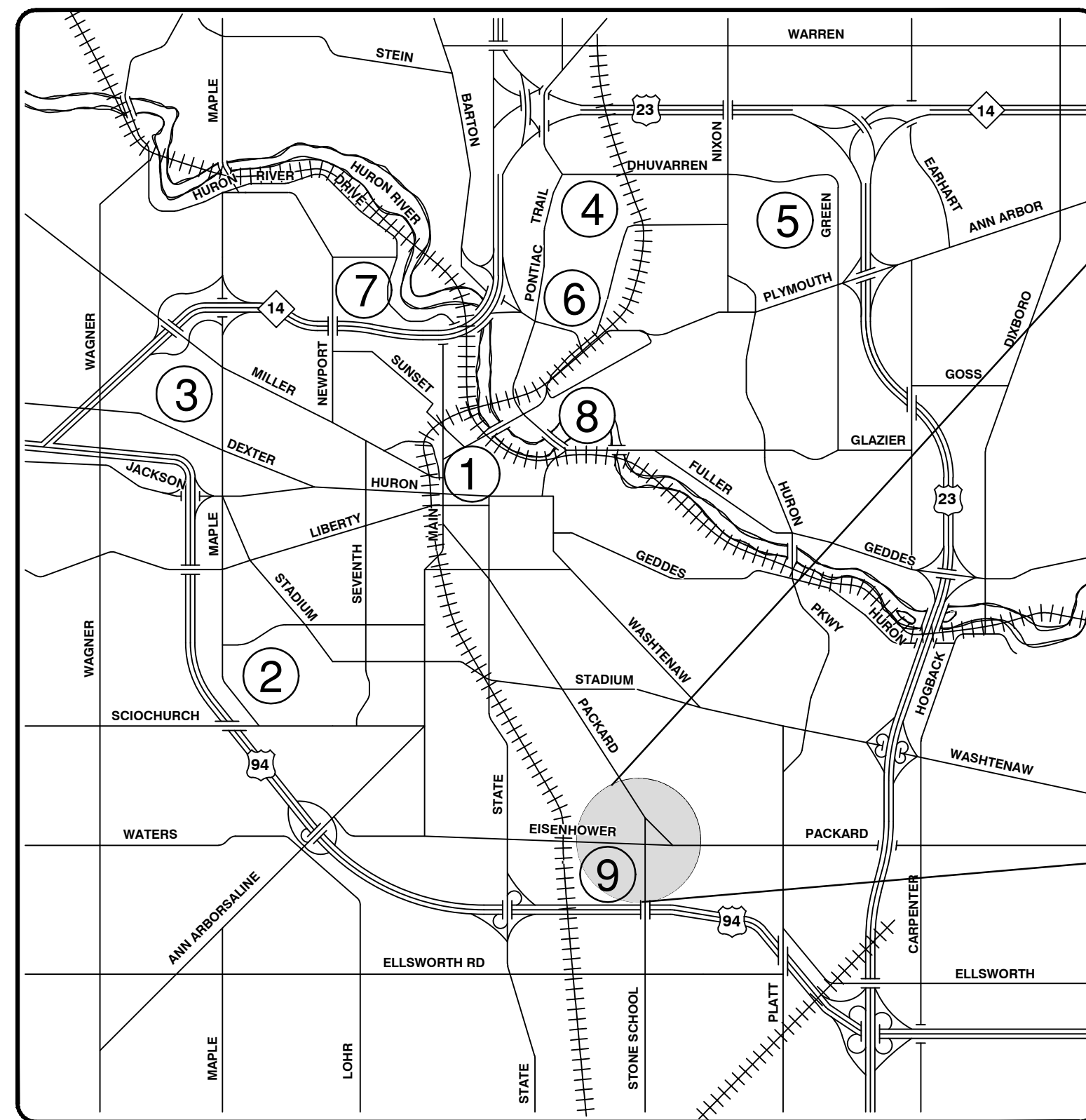
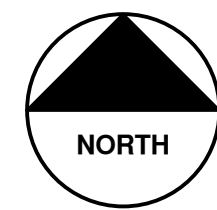

VICINITY MAP

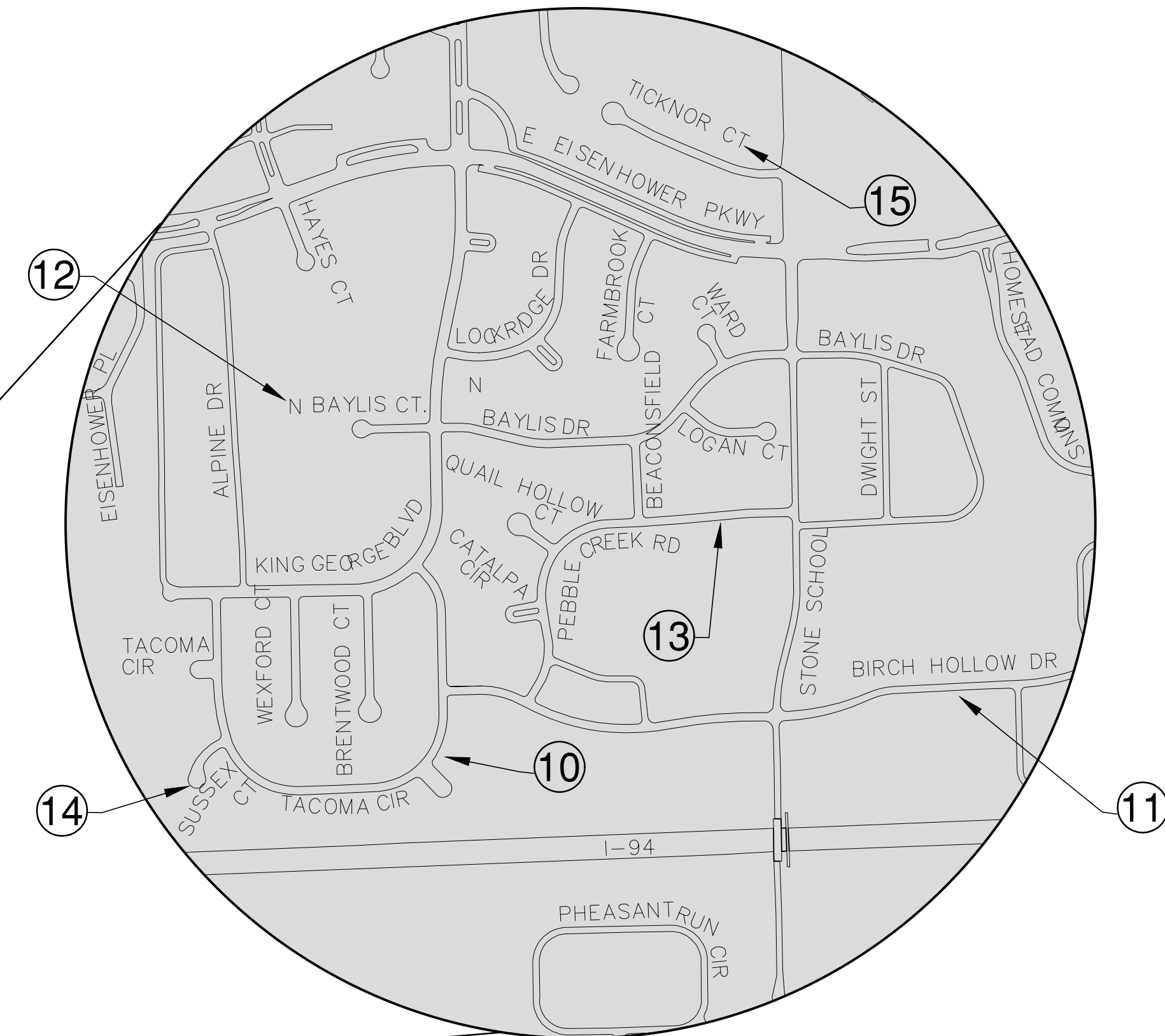

S:\Project Management\Drafting\autocad\2016004\Plan Production\2016004COV.dwg Dwg Created: 25-Nov-15 - _g2 standard bw.stb - Plot Date: 15-Mar-16

PROJECT MANAGEMENT SERVICE UNIT

PREPARED UNDER THE SUPERVISION OF

David Arthur Dykman

DAVID ARTHUR DYKMAN P.E. - MI LICENSE No. 52912
PROJECT MANAGER

2/11/2016
DATE

PROJECT MANAGEMENT - PUBLIC SERVICES - CITY OF ANN ARBOR
 PROJECT DESCRIPTION
 MAJOR AND LOCAL STREET RESURFACING
 SHEET No.
 1 OF 98
 DRAWING No.
 2016004 - 1

STREET RESURFACING - 2016 - ITB No. 4422 - 2016004



CITY OF ANN ARBOR PROJECT MANAGEMENT STREET RESURFACING - 2016 LOCATION: DEPOT STREET

ITB No. 4422 FILE No. 2016004

CONSTRUCTION METHOD AND SEQUENCING

WORK ON THIS STREET INCLUDES, BUT IS NOT LIMITED TO, THE FOLLOWING ITEMS. COMPLETE THE WORK IN ACCORDANCE WITH THE PLANS AND SPECIFICATIONS, AS DIRECTED BY THE ENGINEER, AND UTILIZING PART WIDTH TWO (2) PHASE CONSTRUCTION. PERFORM THE WORK IN THE ORDER INDICATED BELOW UNLESS OTHERWISE AUTHORIZED OR DIRECTED BY THE ENGINEER. COMPLETE ITEMS 7 THRU 15 UTILIZING THE M.O.T. PLAN CURRENTLY IN PLACE, LANE CLOSURES, AND FLAG CONTROL OPERATIONS AS DIRECTED BY THE ENGINEER.

PHASE I

- IMPLEMENT MAINTENANCE OF TRAFFIC (M.O.T.) PLAN, AND INSTALL SOIL EROSION AND SEDIMENTATION CONTROL MEASURES.
- CONDUCT REMOVAL WORK RELATED TO PAVEMENT, DRAINAGE, AND CONCRETE ITEMS WITH EXCEPTION TO COLDMILLING.
- INSTALL PROPOSED DRAINAGE STRUCTURES, STORM SEWER, AND UNDERDRAIN AS REQUIRED.
- PERFORM ALL CONCRETE WORK, INCLUDING RESTORATION.
- TEMPORARY LOWER ALL STRUCTURE COVERS LOCATED WITHIN THE EXISTING PAVEMENT AREA, INCLUDING GATE AND MONUMENT BOXES.

PHASE II

- REPEAT ITEMS 1 THRU 5 IN THE ORDER SHOWN ABOVE.
- REMOVE 3.5 INCHES OF EXISTING HMA SURFACE BY COLDMILLING. THIS MAY INCLUDE GRANULAR BASE MATERIAL. DEPTH TO BE DETERMINED BY THE ENGINEER. PROOF ROLL WITH FULLY LOADED TRUCK.
- PERFORM ALL JOINT AND CRACK CLEANOUT. HMA/HAND PATCHING, UNDERCUTS AND/OR BASE REPAIRS AS REQUIRED.
- GRADE, SHAPE, AND COMPACT THE EXISTING BASE MATERIAL AS REQUIRED.
- ADJUST ALL STRUCTURE COVERS, INCLUDING GATE AND MONUMENT BOXES, TO THEIR FINISH ELEVATION.
- CLEAN PAVEMENT AND PLACE 2.0 INCH LEVELING COURSE HMA MIX (MAJOR STREETS).
- CLEAN PAVEMENT AND PLACE 1.5 INCH TOP COURSE HMA MIX (MAJOR STREETS).
- CLEAN PAVEMENT AND PLACE HMA APPROACHES AS REQUIRED.
- CLEAN PAVEMENT AND COMPLETE ALL PAVEMENT MARKINGS.
- COMPLETE ALL MISCELLANEOUS CONSTRUCTION INCLUDING ALL CLEAN UP AND FINAL RESTORATION.
- REMOVE ALL TRAFFIC CONTROL DEVICES, AND MISS DIG FLAGS.

NOTES

FOR PROTECTION OF UNDERGROUND UTILITIES AND IN CONFORMANCE WITH PUBLIC ACT 174 OF 2013, THE CONTRACTOR SHALL CALL 811 OR 1-800-482-7171 A MINIMUM OF THREE FULL WORKING DAYS, EXCLUDING SATURDAYS, SUNDAYS, AND HOLIDAYS, PRIOR TO BEGINNING EACH EXCAVATION IN AREAS WHERE PUBLIC UTILITIES HAVE NOT BEEN PREVIOUSLY LOCATED. MEMBERS WILL THUS BE ROUTINELY NOTIFIED. THIS DOES NOT RELIEVE THE CONTRACTOR OF THE RESPONSIBILITY OF NOTIFYING UTILITY OWNERS WHO MAY NOT BE A PART OF THE "MISS DIG" ALERT SYSTEM.

THE UNDERGROUND LOCATIONS SHOWN FOR NATURAL GAS, TELEPHONE, ELECTRICAL POWER, CABLE TV AND FIBER OPTIC LINES ARE APPROXIMATE. THE CITY OF ANN ARBOR ASSUMES NO RESPONSIBILITY FOR THEIR ACCURATE REPRESENTATION IN THIS DRAWING. MISS DIG MUST BE CONTACTED PRIOR TO CONSTRUCTION TO LOCATE THESE UTILITIES.

THE IMPROVEMENTS COVERED BY THESE PLANS SHALL BE PERFORMED IN ACCORDANCE WITH MICHIGAN DEPARTMENT OF TRANSPORTATION (MDOT) 2012 STANDARD SPECIFICATIONS FOR CONSTRUCTION, INCLUDING REFERENCED MDOT PUBLICATIONS, AND THE PROJECT CONTRACT DOCUMENTS.

QUANTITIES			
Item Code	Item Description	Units	Quantity
2030011	Dr Structure, Rem	Ea	3.000
2030015	Sewer, Rem, Less than 24 inch	Ft	30.000
2047001	Curb, Gutter, and Curb and Gutter, Any Type, Rem	Ft	1,497.000
2047011	Sidewalk, Sidewalk Ramp, and Driveway Approach, Any Thickness, Rem	Sft	97.000
2047050	Exploratory Excavation (0-10' Deep) Tr Det I	Ea	1.000
2057011	Grading, Driveway Approach	Syd	35.000
2057011	Grading, Sidewalk	Syd	49.000
2057011	Grading, Sidewalk Ramp	Syd	14.000
2057021	Subgrade Undercutting, Type IIA	Cft	636.000
2087050	Erosion Control, Inlet Filter	Ea	22.000
4020987	Sewer, CI IV, 12 inch, Tr Det B	Ft	30.000
4030200	Dr Structure, 24 inch dia	Ea	2.000
4037050	Dr Structure Cover, Special	Ea	4.000
4037050	Dr Structure Cover, Type B, Modified	Ea	5.000
4037050	Dr Structure Cover, Type K, Modified	Ea	5.000
4037050	Dr Structure, Adj, Case 1, Modified	Ea	20.000
4037050	Dr Structure, Double Inlet	Ea	1.000
4037050	Dr Structure, Temp Lowering, Modified	Ea	26.000
5010003	Cold Milling HMA Surface	Ton	1,266.000
5010005	HMA Surface, Rem	Syd	168.000
5010051	HMA, 4E3	Ton	719.000
5010057	HMA, 5E3	Ton	539.000
5010061	HMA, Approach	Ton	8.000
6027021	Flowable Fill	Cyd	56.000
6030005	Cement	Cyd	3.000
8017011	Driveway, Nonreinf Conc, 6 inch, Modified	Syd	35.000
8027001	Curb and Gutter, Conc	Ft	1,242.000
8027001	Driveway Opening, Conc, Det M, Modified	Ft	268.000
8037001	Detectable Warning Surface, Modified	Ft	25.000
8037010	Sidewalk Ramp, Conc, 6 inch, Modified	Sft	120.000
8037010	Sidewalk, Conc or Clay Brick Pavers, Rem	Sft	25.000
8037010	Sidewalk, Conc, 4 inch, Modified	Sft	400.000
8037010	Sidewalk, Conc, 6 inch, Modified	Sft	35.000
8110153	Pav Mrkg, Sprayable Thermopl, 4 inch, White	Ft	132.000
8110154	Pav Mrkg, Sprayable Thermopl, 4 inch, Yellow	Ft	3,208.000
8110197	Pav Mrkg, Thermopl, 6 inch, Crosswalk	Ft	133.000
8110213	Pav Mrkg, Thermopl, 12 inch, Cross Hatching, Yellow	Ft	36.000
8110218	Pav Mrkg, Thermopl, 24 inch, Stop Bar	Ft	53.000
8117001	Pav Mrkg, Thermopl, 24 inch, Crosswalk	Ft	200.000
8117050	Pav Mrkg, Thermopl, Only	Ea	1.000
8117050	Pav Mrkg, Thermopl, Lt Turn Arrow Sym	Ea	1.000
8120012	Barricade, Type III, High Intensity, Double Sided, Lighted, Furn	Ea	6.000
8120013	Barricade, Type III, High Intensity, Double Sided, Lighted, Oper	Ea	6.000
8120140	Lighted Arrow, Type C, Furn	Ea	2.000
8120141	Lighted Arrow, Type C, Oper	Ea	2.000
8120260	Plastic Drum, High Intensity, Lighted, Furn	Ea	57.000
8120261	Plastic Drum, High Intensity, Lighted, Oper	Ea	57.000
8120330	Sign, Portable, Changeable Message, Furn	Ea	3.000
8120331	Sign, Portable, Changeable Message, Oper	Ea	3.000
8120350	Sign, Type B, Temp, Prismatic, Furn	Sft	78.000
8120351	Sign, Type B, Temp, Prismatic, Oper	Sft	78.000
8167011	Slope Restoration	Syd	549.000
8197050	Handhole Assembly, 12 inch X 18 inch	Ea	2.000
8217050	Monument Box Adjust	Ea	2.000
8230431	Gate Box, Adj, Case 1	Ea	10.000

CONSTRUCTION KEY	
KEY	ASSOCIATED PAY ITEM(S)
AA	• Dr Structure, Adj, Case 1, Modified • Dr Structure, Adj, Case 2, Modified • Dr Structure, Temp Lowering, Modified
AB	• Dr Structure, Temp Lowering, Modified • Gate Box, Adj, Case 1 • Gate Box, Adj, Case 2 • Monument Box Adjust
ADST	• Dr Structure, Adj, Add Depth, Modified
AK	• Dr Structure, Adj, Case 1, Modified
C4	• Sidewalk, Sidewalk Ramp, and Driveway Approach, Any Thickness, Rem • Grading, Sidewalk • Sidewalk, Conc, 4 inch, Modified
C4HE	• Sidewalk, Sidewalk Ramp, and Driveway Approach, Any Thickness, Rem • Grading, Sidewalk • Cement • Sidewalk, Conc, 4 inch, Modified
C6	• Sidewalk, Sidewalk Ramp, and Driveway Approach, Any Thickness, Rem • Grading, Sidewalk • Grading, Sidewalk Ramp • Detectable Warning Surface, Modified • Sidewalk Ramp, Conc, 6 inch, Modified • Sidewalk, Conc, 6 inch, Modified
C8	• Grading, Driveway Approach • Driveway, Nonreinf Conc, 8 inch, Modified • Sidewalk, Sidewalk Ramp, and Driveway Approach, Any Thickness, Rem • Grading, Driveway Approach • Grading, Sidewalk • Grading, Sidewalk Ramp
CHE	• Cement • Driveway, Nonreinf Conc, 6 inch, Modified • Driveway, Nonreinf Conc, 8 inch, Modified • Detectable Warning Surface, Modified • Sidewalk Ramp, Conc, 6 inch, Modified • Sidewalk, Conc, 6 inch, Modified
C/G	• Curb, Gutter, and Curb and Gutter, Any Type, Rem • Curb and Gutter, Conc
C/GHE	• Curb, Gutter, and Curb and Gutter, Any Type, Rem • Cement • Driveway Opening, Conc, Det M, Modified
CP	• Grading, Sidewalk • Sidewalk, Conc, 4 inch, Modified
CR	• Sidewalk, Sidewalk Ramp, and Driveway Approach, Any Thickness, Rem • Dr Structure, Rem
DS	• Sewer, Rem, Less than 24 inch • Dr Structure, 24 inch dia • Dr Structure, Rem
DSDI	• Sewer, Rem, Less than 24 inch • Dr Structure, Double Inlet
PT	• Dr Structure, Point
RRA	• Dr Structure Cover, Type B • Dr Structure Cover, Type B, Special • Dr Structure, Adj, Case 1, Modified • Dr Structure, Temp Lowering, Modified
RRK	• Dr Structure Cover, Type K • Dr Structure, Adj, Case 1, Modified
RS	• Dr Structure, Reconstruct
TYPE I	• Plastic Drum, High Intensity, Lighted, Furn • Plastic Drum, High Intensity, Lighted, Oper
TYPE II	• Barricade, Type III, High Intensity, Double Sided, Lighted, Furn • Barricade, Type III, High Intensity, Double Sided, Lighted, Oper

LEGEND	
SYMBOL	DESCRIPTION
⊙	EXISTING SANITARY SEWER MANHOLE
⊙	EXISTING STORM SEWER MANHOLE
⊗	EXISTING WATER MAIN VALVE IN WELL
+	WATER MAIN GATE VALVE IN BOX
⊕	FIRE HYDRANT
⊙	MICHCON GAS CO. VALVE BOX/WELL
⊙	AMERITECH TELEPHONE VAULT
⊙	ELECTRIC MANHOLE
⊙	SOIL BORING
□	EXISTING STORM SEWER INLET
□	MONUMENT BOX
▬	REMOVE AND REPLACE CONC. SIDEWALK
▬	PLACE CONCRETE SIDEWALK
▬	REMOVE & REPLACE CONC. CURB & GUTTER
▬	CONSTRUCTION LIMITS
▬	6" WRAPPED UNDERDRAIN
▬	REMOVE CONCRETE SIDEWALK
▬	SUBGRADE UNDERCUT

QUANTITIES			
Sign, Type B, Temp, Prismatic			
Quantity	Sign Code	Description	Total
6.0	D3-1	Street Name Sign	24.000
6.0	W20-1	Road Work Ahead Sign	54.000
		TOTAL	78.000

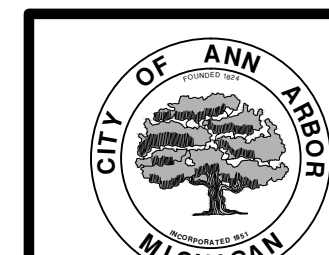

PROJECT MANAGEMENT SERVICES UNIT
CITY OF ANN ARBOR PUBLIC SERVICES
301 EAST HURON STREET, P.O. BOX 8647
ANN ARBOR, MICHIGAN 48107-8647
734-794-6410 www.a2gov.org

S:\Project Management\Drafting\autocad\2016004\Plan Production\2016004-DEPOT ST.dwg Dwg Created: 24-Nov-15 - a2 standard bw.stb - Plot Date: 15-Mar-16

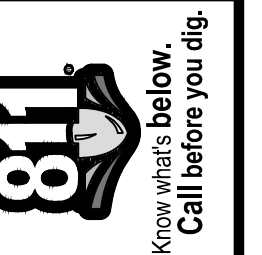

PROJECT MANAGEMENT - PUBLIC SERVICES - CITY OF ANN ARBOR
STREET RESURFACING - 2016
DEPOT STREET
DRAWING No. 2016004-2

S:\Project Management\Drafting\autocad\2016004\Plan Production\2016004-DEPOT ST.dwg Dwg Created: 24-Nov-15 - _a2 standard bw.stb - Plot Date: 15-Mar-16

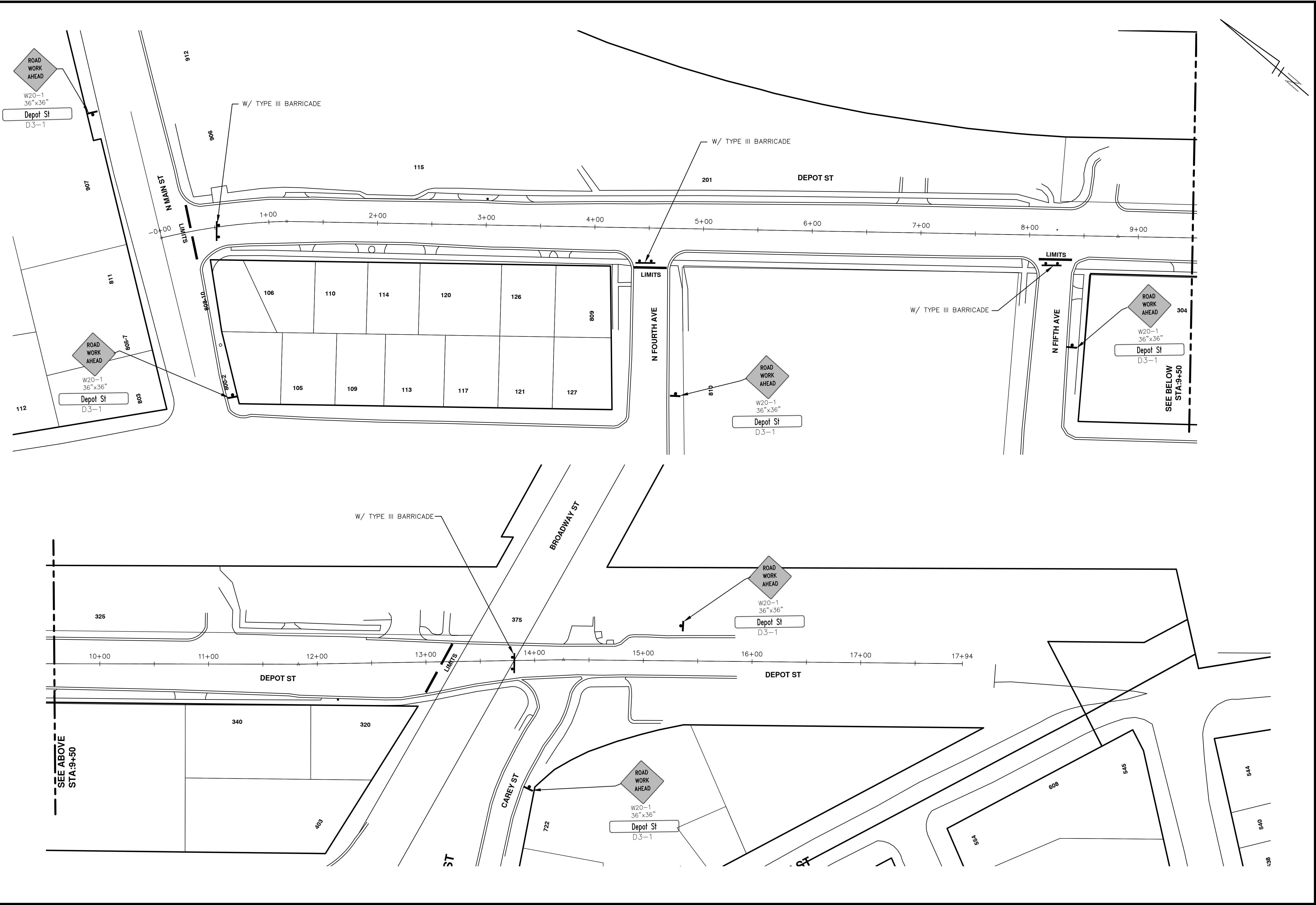

PROJECT MANAGEMENT - PUBLIC SERVICES - CITY OF ANN ARBOR
STREET RESURFACING - 2016
 DEPOT STREET
 TRAFFIC CONTROL

SCALE PLAN: 1" = 40'
 DRAWING No. 2016004-3

811
 Know what's below.
 Call Before you dig.

REV.	DESCRIPTION	DATE	DRAWN	CHECKED
02	ADDENDUM #3	3-15-2016	DAD	DAD
01	ADDENDUM #1	3-7-2016	DAD	DAD
00	BID SET	2-22-2016	GS AH JK	DAD

CITY OF ANN ARBOR
 PUBLIC SERVICES
 301 EAST HURON STREET
 P.O. BOX 8647
 ANN ARBOR MI 48106-8647
 www.a2gov.org

CITY OF ANN ARBOR
 MICHIGAN

S:\Project Management\Drafting\autocad\2016004\Plan Production\2016004-DEPOT ST.dwg Dwg Created: 24-Nov-15 - _a2 standard bw.stb - Plot Date: 15-Mar-16

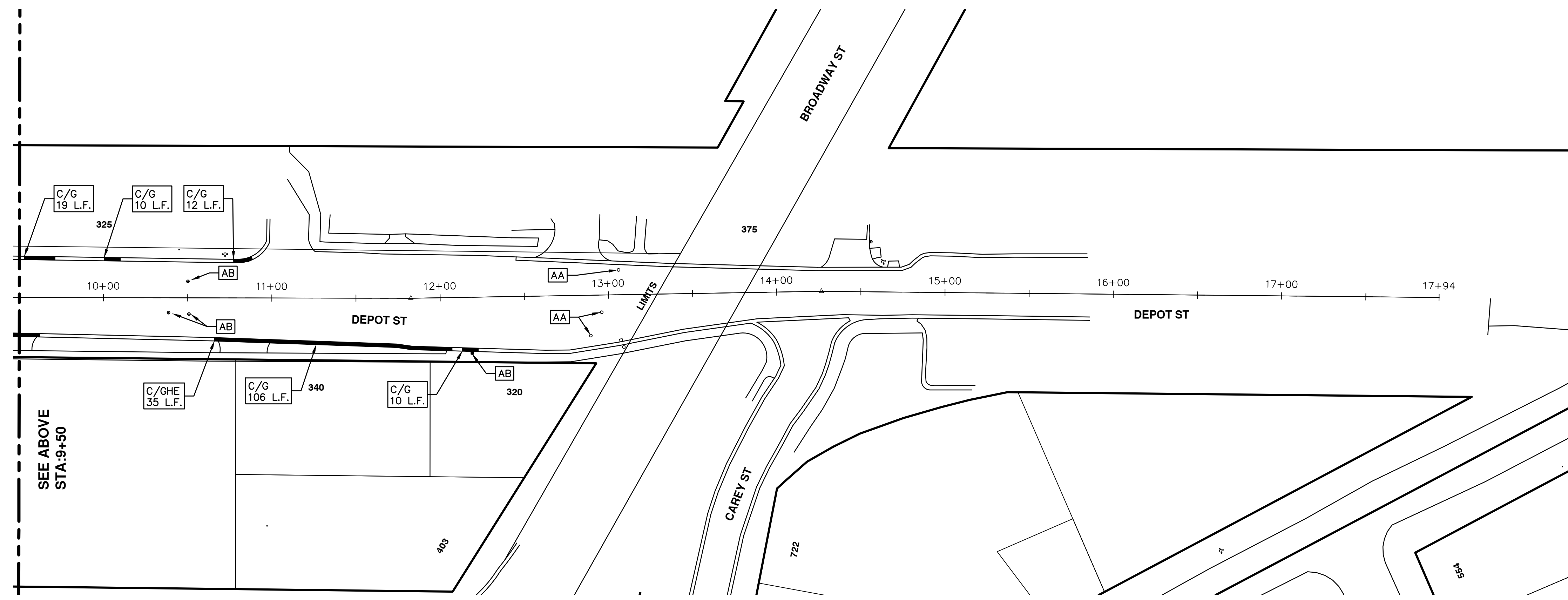
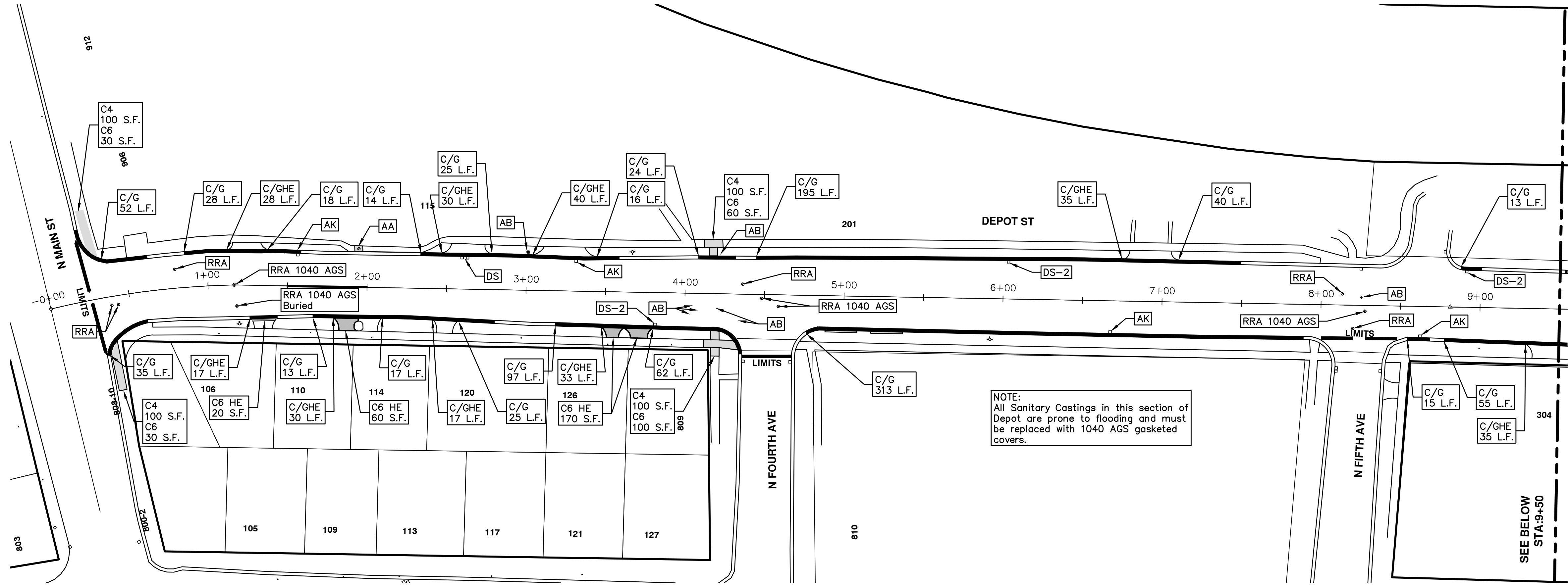

REV.	DESCRIPTION	DATE	DRAWN	CHECKED
02	ADDENDUM #3	3-15-2016	DAD	DAD
01	ADDENDUM #1	3-7-2016	DAD	DAD
00	BID SET	2-22-2016	GS AH UK	DAD

CITY OF ANN ARBOR
PUBLIC SERVICES
301 EAST HURON STREET
ANN ARBOR, MI 48106-1667
www.a2gov.org

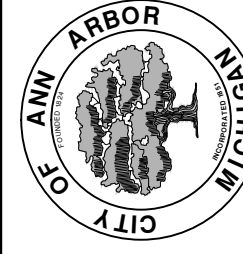

PROJECT MANAGEMENT - PUBLIC SERVICES - CITY OF ANN ARBOR
STREET RESURFACING - 2016
DEPOT STREET
RESURFACING

SCALE PLAN: 1" = 40'
DRAWING No. 2016004-4

S:\Project Management\Drafting\autocad\2016004\Plan Production\2016004-DEPOT ST.dwg Dwg Created: 24-Nov-15 - _a2 standard bw.stb - Plot Date: 15-Mar-16

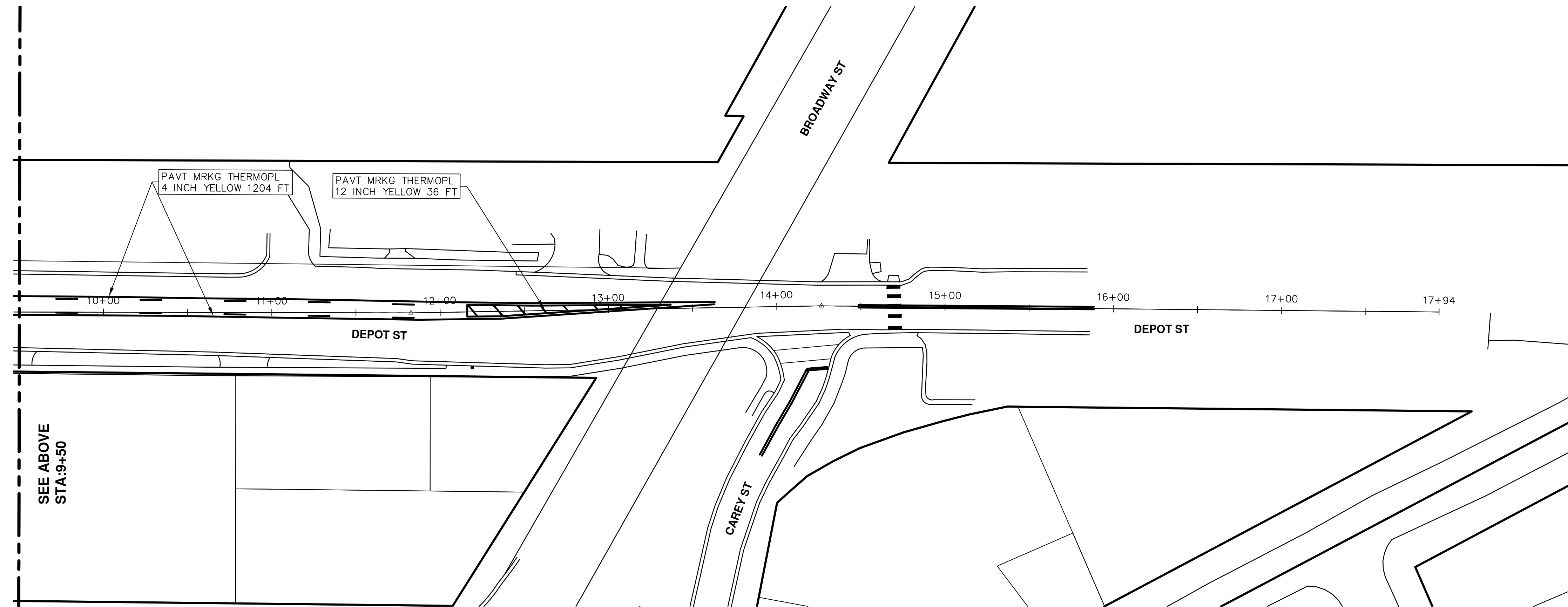
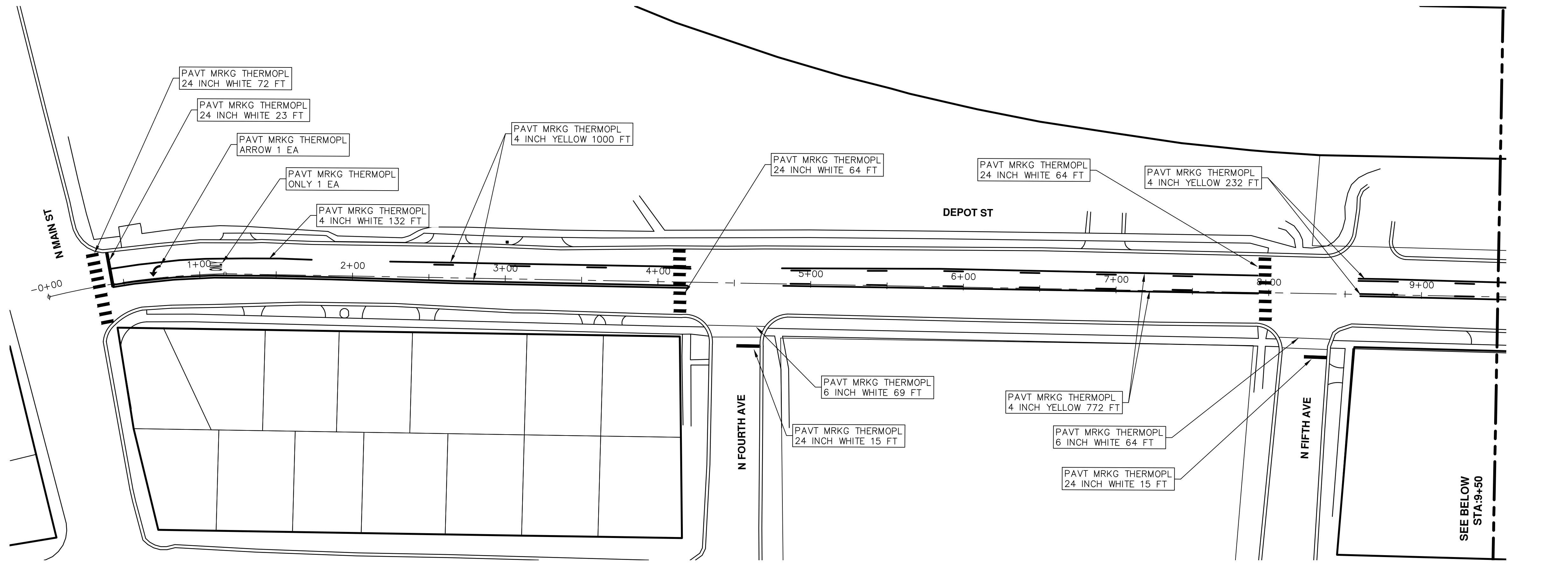

REV.	DESCRIPTION	DATE	DRAWN	CHECKED
02	ADDENDUM #3	3-15-2016	DAD	DAD
01	ADDENDUM #1	3-7-2016	DAD	DAD
00	BID SET	2-22-2016	GS AH JK	DAD

CITY OF ANN ARBOR
PUBLIC SERVICES
301 EAST HURON STREET
ANN ARBOR MI 48106-8647
www.a2gov.org



PROJECT MANAGEMENT - PUBLIC SERVICES - CITY OF ANN ARBOR
STREET RESURFACING - 2016
DEPOT STREET
PAVEMENT MARKINGS

SCALE PLAN: 1" = 40'
DRAWING No. 2016004-5



CITY OF ANN ARBOR PROJECT MANAGEMENT STREET RESURFACING - 2016 LOCATION: PAULINE BOULEVARD

ITB No. 4422 FILE No. 2016004

CONSTRUCTION METHOD AND SEQUENCING

WORK ON THIS STREET INCLUDES, BUT IS NOT LIMITED TO, THE FOLLOWING ITEMS. COMPLETE THE WORK IN ACCORDANCE WITH THE PLANS AND SPECIFICATIONS, AS DIRECTED BY THE ENGINEER, AND UTILIZING PART WIDTH TWO (2) PHASE CONSTRUCTION. PERFORM THE WORK IN THE ORDER INDICATED BELOW UNLESS OTHERWISE AUTHORIZED OR DIRECTED BY THE ENGINEER. COMPLETE ITEMS 7 THRU 14 UTILIZING THE M.O.T. PLAN CURRENTLY IN PLACE, LANE CLOSURES, AND FLAG CONTROL OPERATIONS AS DIRECTED BY THE ENGINEER.

PHASE I

- IMPLEMENT MAINTENANCE OF TRAFFIC (M.O.T.) PLAN, AND INSTALL SOIL EROSION AND SEDIMENTATION CONTROL MEASURES.
- CONDUCT REMOVAL WORK RELATED TO PAVEMENT, DRAINAGE, AND CONCRETE ITEMS WITH EXCEPTION TO COLDMILLING.
- INSTALL PROPOSED DRAINAGE STRUCTURES, STORM SEWER, AND UNDERDRAIN AS REQUIRED.
- PERFORM ALL CONCRETE WORK, INCLUDING RESTORATION.
- TEMPORARY LOWER ALL STRUCTURE COVERS LOCATED WITHIN THE EXISTING PAVEMENT AREA, INCLUDING GATE AND MONUMENT BOXES.

PHASE II

- REPEAT ITEMS 1 THRU 5 IN THE ORDER SHOWN ABOVE.
- REMOVE 1.5 INCHES OF EXISTING HMA SURFACE BY COLDMILLING. THIS MAY INCLUDE GRANULAR BASE MATERIAL. DEPTH TO BE DETERMINED BY THE ENGINEER. PROOF ROLL WITH FULLY LOADED TRUCK.
- PERFORM ALL JOINT AND CRACK CLEANOUT. HMA/HAND PATCHING, UNDERCUTS AND/OR BASE REPAIRS AS REQUIRED.
- GRADE, SHAPE, AND COMPACT THE EXISTING BASE MATERIAL AS REQUIRED.
- ADJUST ALL STRUCTURE COVERS, INCLUDING GATE AND MONUMENT BOXES, TO THEIR FINISH ELEVATION.
- CLEAN PAVEMENT AND PLACE 1.5 INCH TOP COURSE HMA MIX (MAJOR STREETS) OVER ENTIRE STREET.
- CLEAN PAVEMENT AND PLACE HMA APPROACHES AS REQUIRED.
- CLEAN PAVEMENT AND COMPLETE ALL PAVEMENT MARKINGS.
- COMPLETE ALL MISCELLANEOUS CONSTRUCTION INCLUDING ALL CLEAN UP AND FINAL RESTORATION.
- REMOVE ALL TRAFFIC CONTROL DEVICES, AND MISS DIG FLAGS.

NOTES:

FOR PROTECTION OF UNDERGROUND UTILITIES AND IN CONFORMANCE WITH PUBLIC ACT 174 OF 2013, THE CONTRACTOR SHALL CALL 811 OR 1-800-482-7171 A MINIMUM OF THREE FULL WORKING DAYS, EXCLUDING SATURDAYS, SUNDAYS, AND HOLIDAYS, PRIOR TO BEGINNING EACH EXCAVATION IN AREAS WHERE PUBLIC UTILITIES HAVE NOT BEEN PREVIOUSLY LOCATED. MEMBERS WILL THUS BE ROUTINELY NOTIFIED. THIS DOES NOT RELIEVE THE CONTRACTOR OF THE RESPONSIBILITY OF NOTIFYING UTILITY OWNERS WHO MAY NOT BE A PART OF THE "MISS DIG" ALERT SYSTEM.

THE UNDERGROUND LOCATIONS SHOWN FOR NATURAL GAS, TELEPHONE, ELECTRICAL POWER, CABLE TV AND FIBER OPTIC LINES ARE APPROXIMATE. THE CITY OF ANN ARBOR ASSUMES NO RESPONSIBILITY FOR THEIR ACCURATE REPRESENTATION IN THIS DRAWING. MISS DIG MUST BE CONTACTED PRIOR TO CONSTRUCTION TO LOCATE THESE UTILITIES.

THE IMPROVEMENTS COVERED BY THESE PLANS SHALL BE PERFORMED IN ACCORDANCE WITH MICHIGAN DEPARTMENT OF TRANSPORTATION (MDOT) 2012 STANDARD SPECIFICATIONS FOR CONSTRUCTION, INCLUDING REFERENCED MDOT PUBLICATIONS, AND THE PROJECT CONTRACT DOCUMENTS.

QUANTITIES			
Item Code	Item Description	Units	Quantity
2030011	Dr Structure, Rem	Ea	11.000
2030015	Sewer, Rem, Less than 24 inch	Ft	110.000
2047001	Curb, Gutter, and Curb and Gutter, Any Type, Rem	Ft	520.000
2047011	Sidewalk, Sidewalk Ramp, and Driveway Approach, Any Thickness, Rem	Syd	79.000
2057011	Grading, Sidewalk	Syd	46.000
2057011	Grading, Sidewalk Ramp	Syd	34.000
2057021	Subgrade Undercutting, Type IIA	Cyd	158.000
2087050	Erosion Control, Inlet Filler	Ea	22.000
4020987	Sewer, CI IV, 12 inch, Tr Det B	Ft	110.000
4030200	Dr Structure, 24 inch dia	Ea	11.000
4037050	Dr Structure Cover, Type B, Modified	Ea	1.000
4037050	Dr Structure Cover, Type K, Modified	Ea	15.000
4037050	Dr Structure, Adj, Case 1, Modified	Ea	18.000
4037050	Dr Structure, Temp Lowering, Modified	Ea	2.000
5010003	Cold Milling HMA Surface	Ton	814.000
5010005	HMA Surface, Rem	Syd	73.000
5010025	Hand Patching	Tons	1.500
5010057	HMA, 5E3	Ton	801.000
5010061	HMA, Approach	Ton	13.000
6027021	Flowable Fill	Cyd	19.259
8027001	Curb and Gutter, Conc	Ft	466.000
8037001	Detectable Warning Surface, Modified	Ft	30.000
8037010	Sidewalk Ramp, Conc, 6 inch, Modified	Sft	300.000
8037010	Sidewalk, Conc, 4 inch, Modified	Sft	410.000
8110049	Pav Mrkg, Oly Cold Plastic, Direction Arrow Sym, Bike	Ea	5.000
8110058	Pav Mrkg, Oly Cold Plastic, Bike, Small Sym	Ea	5.000
8110153	Pav Mrkg, Sprayable Thermopl, 4 inch, White	Ft	63.000
8110154	Pav Mrkg, Sprayable Thermopl, 4 inch, Yellow	Ft	4,970.000
8110155	Pav Mrkg, Sprayable Thermopl, 6 inch, White	Ft	4,735.000
8110218	Pav Mrkg, Thermopl, 24 inch, Stop Bar	Ft	42.000
8117001	Pav Mrkg, Thermopl, 24 inch, Crosswalk	Ft	176.000
8117050	Pav Mrkg, Thermopl, Only	Ea	1.000
8117050	Pav Mrkg, Thermopl, Rt Turn Arrow Sym	Ea	1.000
8120012	Barricade, Type III, High Intensity, Double Sided, Lighted, Furn	Ea	6.000
8120013	Barricade, Type III, High Intensity, Double Sided, Lighted, Oper	Ea	6.000
8120140	Lighted Arrow, Type C, Furn	Ea	2.000
8120141	Lighted Arrow, Type C, Oper	Ea	2.000
8120260	Plastic Drum, High Intensity, Lighted, Furn	Ea	105.000
8120261	Plastic Drum, High Intensity, Lighted, Oper	Ea	105.000
8120330	Sign, Portable, Changeable Message, Furn	Ea	2.000
8120331	Sign, Portable, Changeable Message, Oper	Ea	2.000
8120350	Sign, Type B, Temp, Prismatic, Furn	Sft	453.000
8120351	Sign, Type B, Temp, Prismatic, Oper	Sft	453.000
8167011	Slope Restoration	Syd	191.000
8230431	Gate Box, Adj, Case 1	Ea	1.000

CONSTRUCTION KEY	
KEY	ASSOCIATED PAY ITEM(S)
AA	• Dr Structure, Adj, Case 1, Modified • Dr Structure, Adj, Case 2, Modified • Dr Structure, Temp Lowering, Modified
AB	• Dr Structure, Temp Lowering, Modified • Gate Box, Adj, Case 1 • Gate Box, Adj, Case 2 • Monument Box Adjust
ADST	• Dr Structure, Adj, Add Depth, Modified
AK	• Dr Structure, Adj, Case 1, Modified
C4	• Sidewalk, Sidewalk Ramp, and Driveway Approach, Any Thickness, Rem • Grading, Sidewalk • Sidewalk, Conc, 4 inch, Modified
C4HE	• Sidewalk, Sidewalk Ramp, and Driveway Approach, Any Thickness, Rem • Grading, Sidewalk • Cement • Sidewalk, Conc, 4 inch, Modified
C6	• Sidewalk, Sidewalk Ramp, and Driveway Approach, Any Thickness, Rem • Grading, Sidewalk • Sidewalk Ramp • Detectable Warning Surface, Modified • Sidewalk Ramp, Conc, 6 inch, Modified • Sidewalk, Conc, 6 inch, Modified
C8	• Grading, Driveway Approach • Driveway, Nonreinf Conc, 8 inch, Modified
C HE	• Sidewalk, Sidewalk Ramp, and Driveway Approach, Any Thickness, Rem • Grading, Driveway Approach • Grading, Sidewalk • Grading, Sidewalk Ramp • Cement • Driveway, Nonreinf Conc, 6 inch, Modified • Driveway, Nonreinf Conc, 8 inch, Modified • Detectable Warning Surface, Modified • Sidewalk Ramp, Conc, 6 inch, Modified • Sidewalk, Conc, 6 inch, Modified
C/G	• Curb, Gutter, and Curb and Gutter, Any Type, Rem • Curb and Gutter, Conc
C/GHE	• Curb, Gutter, and Curb and Gutter, Any Type, Rem • Cement • Driveway Opening, Conc, Det M, Modified
CP	• Grading, Sidewalk • Sidewalk, Conc, 4 inch, Modified
CR	• Sidewalk, Sidewalk Ramp, and Driveway Approach, Any Thickness, Rem • Dr Structure, Rem
DS	• Sewer, Rem, Less than 24 inch • Dr Structure, 24 inch dia • Dr Structure, Rem
DSDI	• Sewer, Rem, Less than 24 inch • Dr Structure, Double Inlet
PT	• Dr Structure, Point
RRA	• Dr Structure Cover, Type B • Dr Structure Cover, Type B, Special • Dr Structure, Adj, Case 1, Modified • Dr Structure, Temp Lowering, Modified
RRK	• Dr Structure Cover, Type K • Dr Structure, Adj, Case 1, Modified
RS	• Dr Structure, Reconstruct
TYPE I	• Plastic Drum, High Intensity, Lighted, Furn • Plastic Drum, High Intensity, Lighted, Oper
TYPE II	• Barricade, Type III, High Intensity, Double Sided, Lighted, Furn • Barricade, Type III, High Intensity, Double Sided, Lighted, Oper

LEGEND	
SYMBOL	DESCRIPTION
⊙	EXISTING SANITARY SEWER MANHOLE
⊕	EXISTING STORM SEWER MANHOLE
⊗	EXISTING WATER MAIN VALVE IN WELL
+	WATER MAIN GATE VALVE IN BOX
⊕+	FIRE HYDRANT
⊙	MICHCON GAS CO. VALVE BOX/WELL
⊕	AMERITECH TELEPHONE VAULT
⊙	ELECTRIC MANHOLE
⊕	SOIL BORING
□	EXISTING STORM SEWER INLET
■	MONUMENT BOX
▬	REMOVE AND REPLACE CONC. SIDEWALK
▬	PLACE CONCRETE SIDEWALK
▬	REMOVE & REPLACE CONC. CURB & GUTTER
---	CONSTRUCTION LIMITS
---	6" WRAPPED UNDERDRAIN
▨	REMOVE CONCRETE SIDEWALK
▬	SUBGRADE UNDERCUT

QUANTITIES				
Sign, Type B, Temp, Prismatic				
Quantity	Sign Code	Description	Area (sft)	Total
16.0	D3-1	Street Name Sign	4.000	64.000
0.0	M4-10L	Detour Arrow (Left) Sign	6.000	0.000
3.0	M4-9S	Detour Sign (w/Thru Arrow)	5.000	15.000
4.0	M4-9R	Detour Sign (w/Right Arrow)	5.000	20.000
5.0	M4-9L	Detour Sign (w/Left Arrow)	5.000	25.000
1.0	M4-8a	End Detour Sign	3.000	3.000
5.0	SP-1	Special Sign	20.000	100.000
1.0	R11-2	Road Closed Sign ("Road Closed")	10.000	10.000
2.0	R11-4	Road Closed Sign ("Road Closed To Thru Traffic")	12.500	25.000
1.0	R3-1	Movement Prohibition Sign ("No Right Turn")	4.000	4.000
1.0	R3-5a	Mandatory Movement Sign (Thru Only)	5.000	5.000
5.0	R6-1L	One Way (Left) Sign	3.000	15.000
7.0	R6-1R	One Way (Right) Sign	3.000	21.000
6.0	W20-1	Road Work Ahead Sign	16.000	96.000
2.0	W20-2	Detour Ahead Sign	9.000	18.000
2.0	W20-3	Road Closed Ahead Sign	16.000	32.000
		TOTAL		453.000

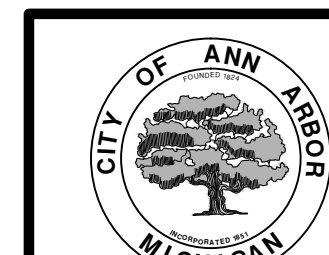

PROJECT MANAGEMENT SERVICES UNIT
CITY OF ANN ARBOR PUBLIC SERVICES
301 EAST HURON STREET, P.O. BOX 8647
ANN ARBOR, MICHIGAN 48107-8647
734-794-6410 www.a2gov.org

S:\Project Management\Drafting\autocad\2016004\Plan Production\2016004-PAULINE BLVD.dwg Dwg Created: 25-Nov-15 - a2 standard bw.stb - Plot Date: 15-Mar-16

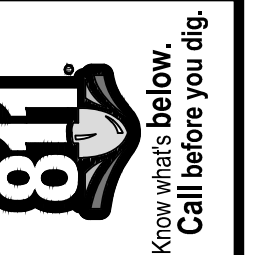

PROJECT MANAGEMENT - PUBLIC SERVICES - CITY OF ANN ARBOR
STREET RESURFACING - 2016
PAULINE BOULEVARD
DRAWING No. 2016004-6

TRAFFIC CONTROL SIGN		
TAG	SIGN	NUM.
1		D3-1 M4-9S 30x24
2		D3-1 M4-9R 30x24
3		D3-1 M4-9L 30x24
6		D3-1 M4-8a 24X18
7		R11-4 60x30
8		SPECIAL 48x60
9		SPECIAL 48x60
10		W20-2 36"x36" D3-1
11		R11-2 48"x60"

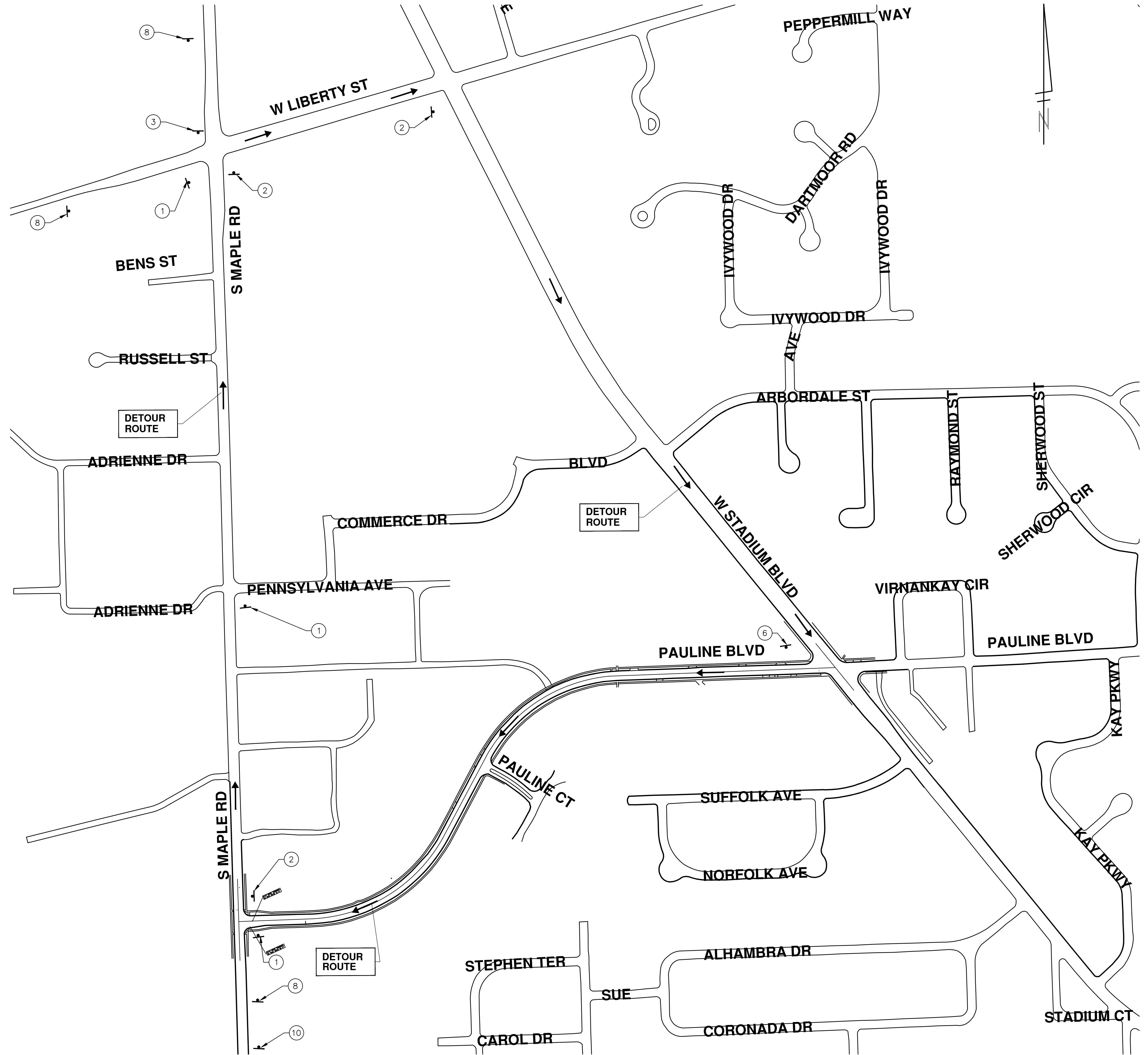

REV.	DESCRIPTION	DATE	DRAWN	CHECKED
02	ADDENDUM #3	3-15-2016	DAD	DAD
01	ADDENDUM #1	3-7-2016	DAD	DAD
00	BID SET	2-22-2016	SS AH JK	DAD

CITY OF ANN ARBOR
 PUBLIC SERVICES
 301 EAST HURON STREET
 ANN ARBOR, MI 48106-0667
 ANN ARBOR: 734-794-4410
 WWW.A2GOV.ORG

PROJECT MANAGEMENT - PUBLIC SERVICES - CITY OF ANN ARBOR
 STREET RESURFACING - 2016
 PAULINE BOULEVARD
 DETOUR

SCALE PLAN: 1" = 200'
 DRAWING No. 2016004-7

S:\Project Management\Drafting\autocad\2016004\Plan Production\2016004-PAULINE BLVD.dwg Dwg Created: 25-Nov-15 - _a2 standard bw.stb - Plot Date: 15-Mar-16

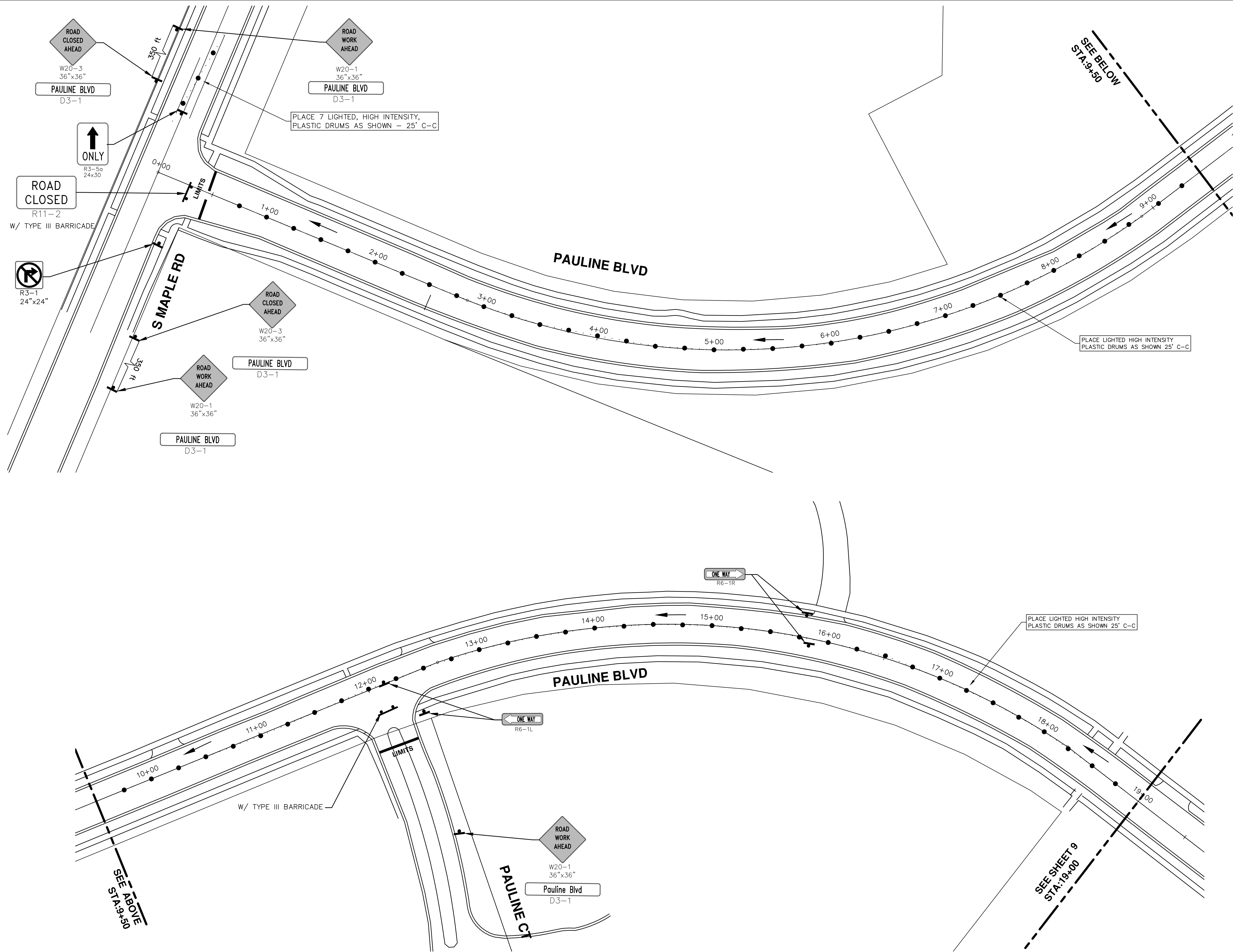

PROJECT MANAGEMENT - PUBLIC SERVICES - CITY OF ANN ARBOR
STREET RESURFACING - 2016
 PAULINE BOULEVARD
 TRAFFIC CONTROL

SCALE PLAN: 1" = 40'
 DRAWING No. 2016004-8

811
 Know what's below.
 Call Before you dig.

REV.	DESCRIPTION	DATE	DRAWN	CHECKED
02	ADDENDUM #3	3-15-2016	DAD	DAD
01	ADDENDUM #1	3-7-2016	DAD	DAD
00	BID SET	2-22-2016	GS AH JK	DAD

CITY OF ANN ARBOR
 PUBLIC SERVICES
 301 EAST HURON STREET
 ANN ARBOR, MI 48106-0647
 www.a2gov.org

CITY OF ANN ARBOR MICHIGAN

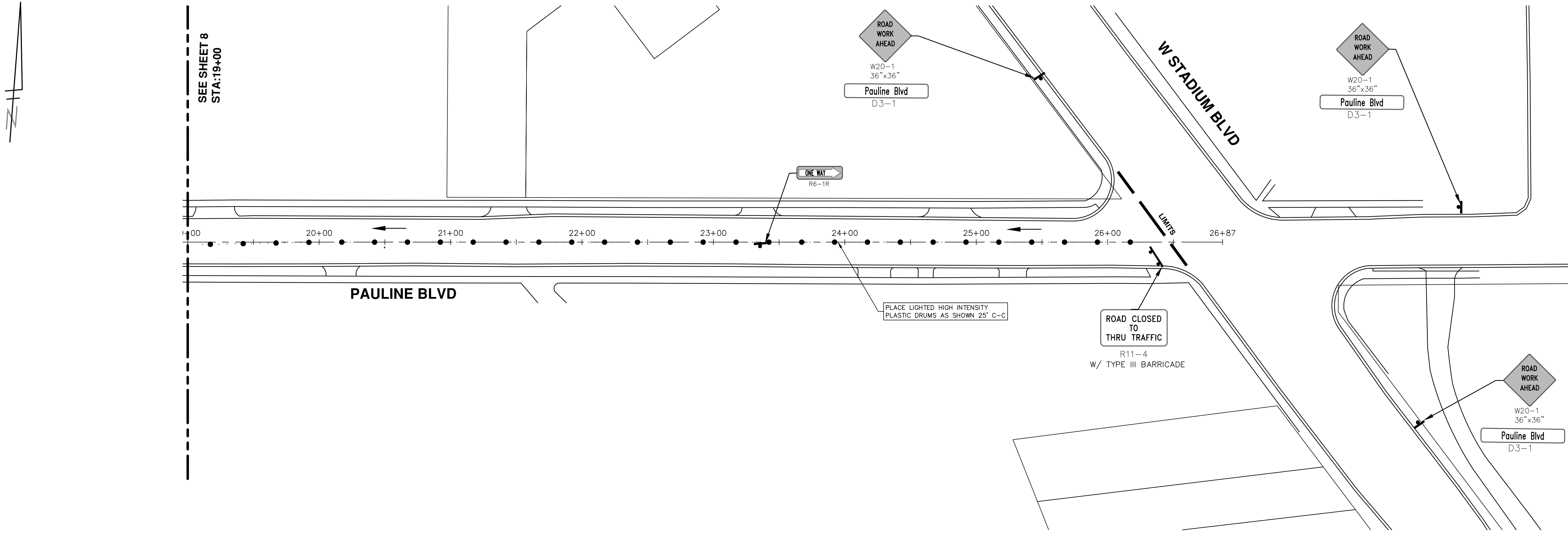

CITY OF ANN ARBOR
PUBLIC SERVICES
301 EAST HURON STREET
ANN ARBOR MI 48106-1667
www.a2gov.org

REV.	DESCRIPTION	DATE	DRAWN	CHECKED
02	ADDENDUM #3	3-15-2016	DAD	DAD
01	ADDENDUM #1	3-7-2016	DAD	DAD
00	BID SET	2-22-2016	GS AH JK	DAD

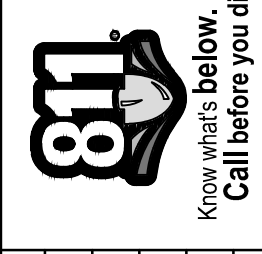

S:\Project Management\Drafting\autocad\2016004\Plan Production\2016004-PAULINE BLVD.dwg Dwg Created: 25-Nov-15 - _a2 standard bw.stb - Plot Date: 15-Mar-16

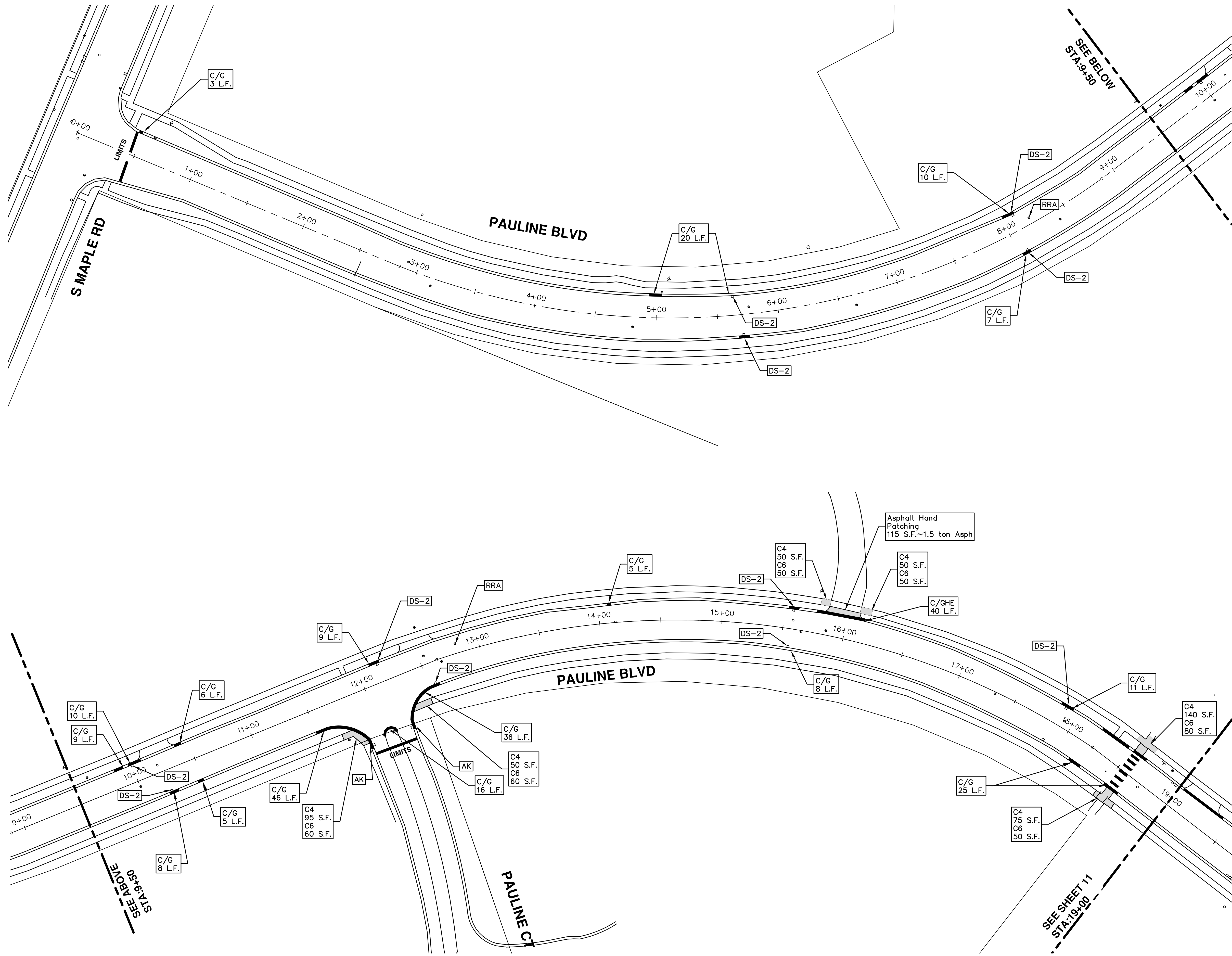

REV.	DESCRIPTION	DATE	DRAWN	CHECKED
02	ADDENDUM #3	3-15-2016	DAD	DAD
01	ADDENDUM #1	3-7-2016	DAD	DAD
00	BID SET	2-22-2016	GS AH JK	DAD

CITY OF ANN ARBOR
 PUBLIC SERVICES
 301 EAST HURON STREET
 ANN ARBOR, MI 48106-0647
 www.a2gov.org



PROJECT MANAGEMENT - PUBLIC SERVICES - CITY OF ANN ARBOR
STREET RESURFACING - 2016
 PAULINE BOULEVARD
 RESURFACING

SCALE PLAN: 1" = 40'
 DRAWING No. 2016004-10

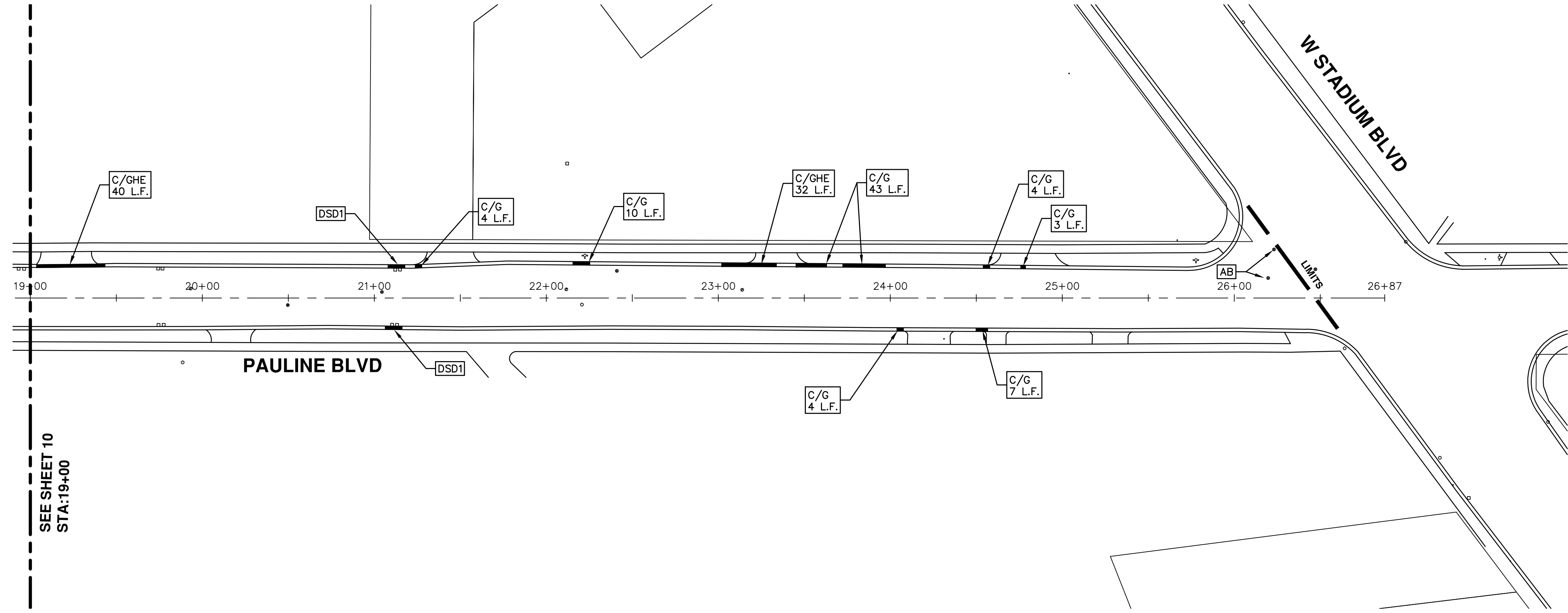

SEE SHEET 10
STA: 19+00



CITY OF ANN ARBOR
PUBLIC SERVICES
301 EAST HURON STREET
ANN ARBOR MI 48106-8647
www.a2gov.org

REV.	DESCRIPTION
02	ADDENDUM #3
01	ADDENDUM #1
00	BID SET

DATE	DRAWN	CHECKED
3-15-2016	DAD	DAD
3-7-2016	DAD	DAD
2-22-2016	GS AH JK	DAD

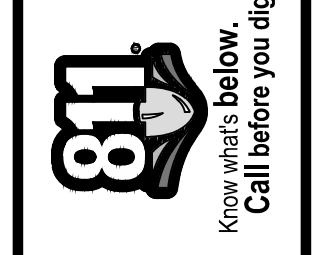

S:\Project Management\Drafting\autocad\2016004\Plan Production\2016004-PAULINE BLVD.dwg Dwg Created: 25-Nov-15 - _a2 standard bw.stb - Plot Date: 15-Mar-16

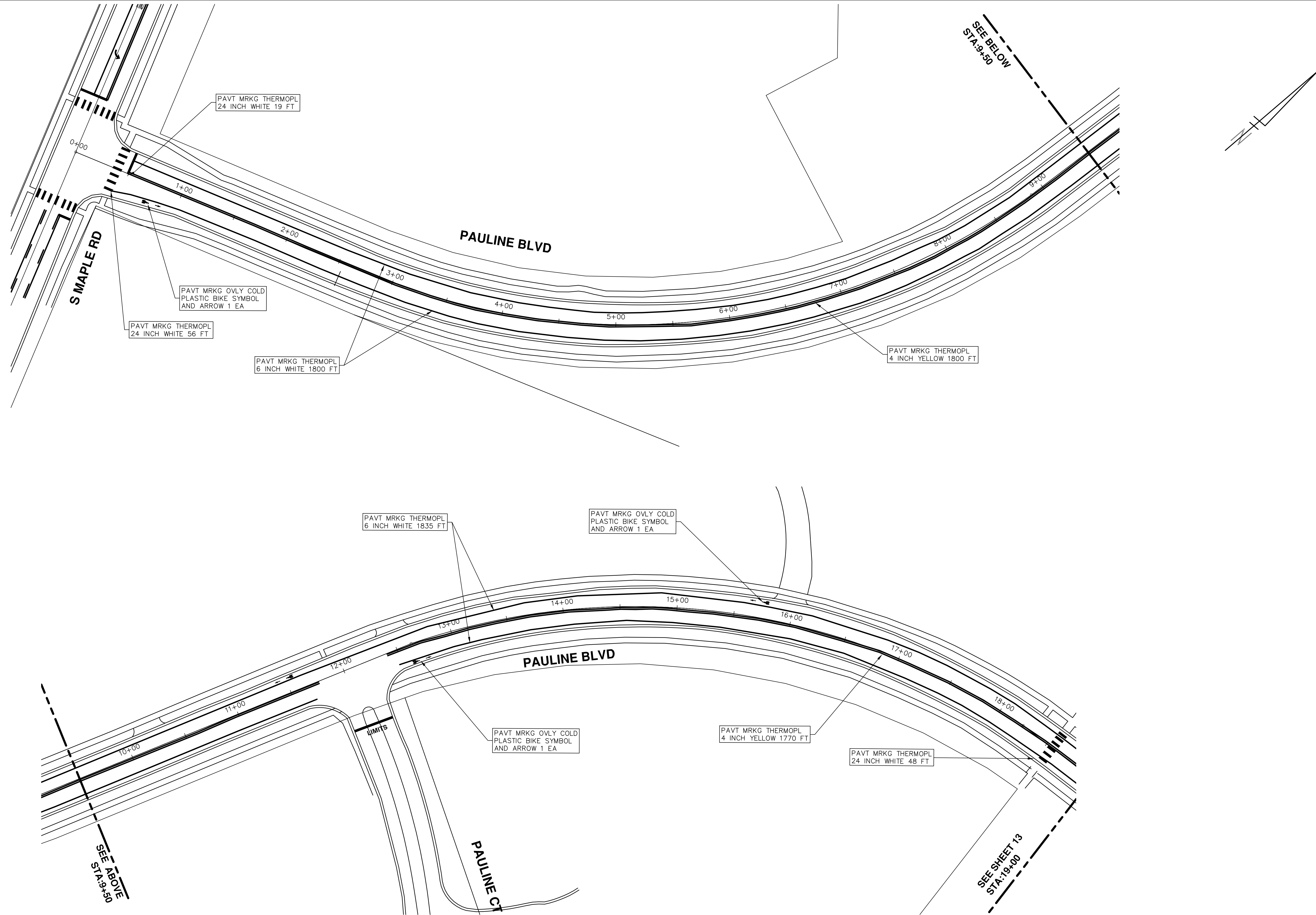

REV.	DESCRIPTION	DATE	DRAWN	CHECKED
02	ADDENDUM #3	3-15-2016	DAD	DAD
01	ADDENDUM #1	3-7-2016	DAD	DAD
00	BID SET	2-22-2016	GS AH JK	DAD

CITY OF ANN ARBOR
 PUBLIC SERVICES
 301 EAST HURON STREET
 ANN ARBOR, MI 48106-0667
 www.a2gov.org

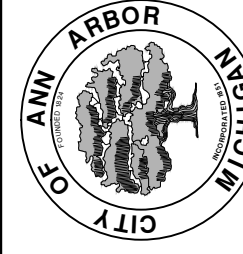

PROJECT MANAGEMENT - PUBLIC SERVICES - CITY OF ANN ARBOR
STREET RESURFACING - 2016
 PAULINE BOULEVARD
 PAVEMENT MARKINGS

SCALE PLAN: 1" = 40'
 DRAWING No. 2016004-12

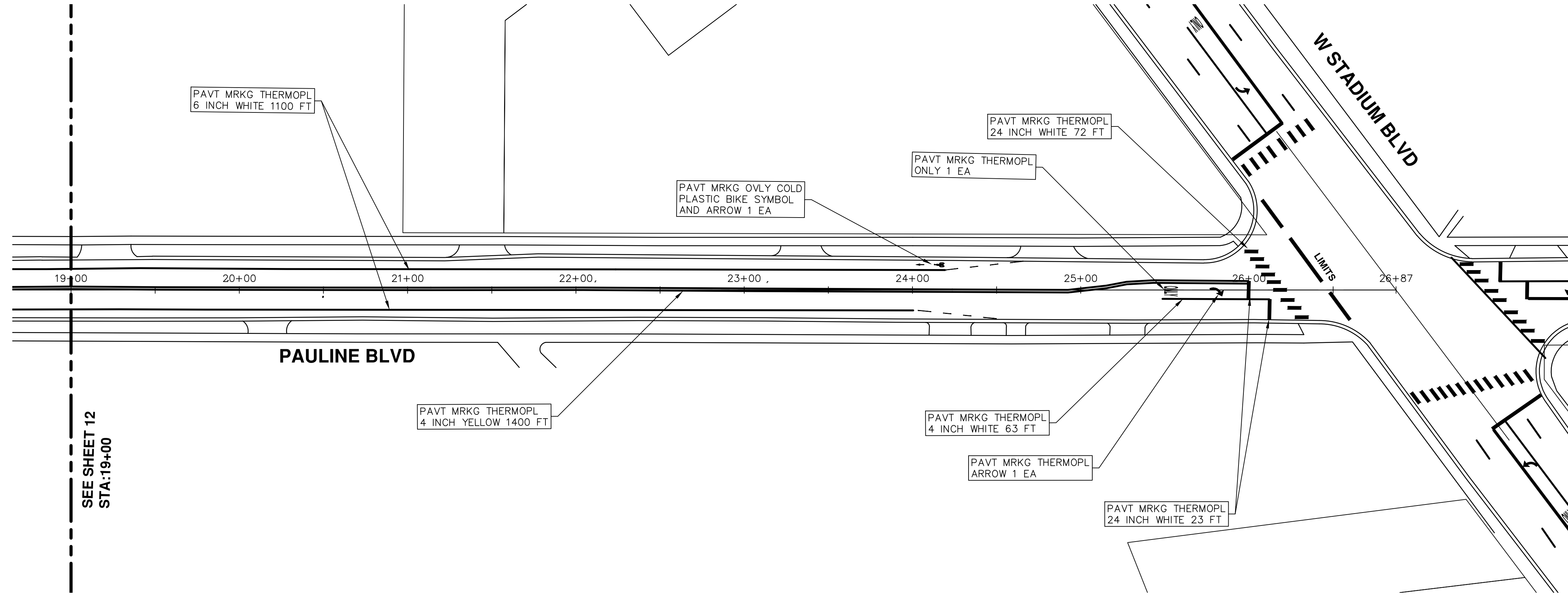

SEE SHEET 12
STA:19+00

PAULINE BLVD

W STADIUM BLVD

REV.	DESCRIPTION
02	ADDENDUM #3
01	ADDENDUM #1
00	BID SET

DATE	DRAWN	CHECKED
3-15-2016	DAD	DAD
3-7-2016	DAD	DAD
2-22-2016	ISS AH JK	DAD



CITY OF ANN ARBOR PROJECT MANAGEMENT STREET RESURFACING - 2016 LOCATION: DEXTER AVENUE

ITB No. 4422 FILE No. 2016004

CONSTRUCTION METHOD AND SEQUENCING

WORK ON THIS STREET INCLUDES, BUT IS NOT LIMITED TO, THE FOLLOWING ITEMS. COMPLETE THE WORK IN ACCORDANCE WITH THE PLANS AND SPECIFICATIONS, AS DIRECTED BY THE ENGINEER, AND UTILIZING PART WIDTH TWO (2) PHASE CONSTRUCTION. PERFORM THE WORK IN THE ORDER INDICATED BELOW UNLESS OTHERWISE AUTHORIZED OR DIRECTED BY THE ENGINEER. COMPLETE ITEMS 7 THRU 14 UTILIZING THE M.O.T. PLAN CURRENTLY IN PLACE, LANE CLOSURES, AND FLAG CONTROL OPERATIONS AS DIRECTED BY THE ENGINEER.

PHASE I

- IMPLEMENT MAINTENANCE OF TRAFFIC (M.O.T.) PLAN, AND INSTALL SOIL EROSION AND SEDIMENTATION CONTROL MEASURES.
- CONDUCT REMOVAL WORK RELATED TO PAVEMENT, DRAINAGE, AND CONCRETE ITEMS WITH EXCEPTION TO COLDMILLING.
- INSTALL PROPOSED DRAINAGE STRUCTURES, STORM SEWER, AND UNDERDRAIN AS REQUIRED.
- PERFORM ALL CONCRETE WORK, INCLUDING RESTORATION.
- TEMPORARY LOWER ALL STRUCTURE COVERS LOCATED WITHIN THE EXISTING PAVEMENT AREA, INCLUDING GATE AND MONUMENT BOXES.

PHASE II

- REPEAT ITEMS 1 THRU 5 IN THE ORDER SHOWN ABOVE.
- REMOVE 1.5 INCHES OF EXISTING HMA SURFACE BY COLDMILLING. THIS MAY INCLUDE GRANULAR BASE MATERIAL. DEPTH TO BE DETERMINED BY THE ENGINEER. PROOF ROLL WITH FULLY LOADED TRUCK.
- PERFORM ALL JOINT AND CRACK CLEANOUT. HMA/HAND PATCHING, UNDERCUTS AND/OR BASE REPAIRS AS REQUIRED.
- GRADE, SHAPE, AND COMPACT THE EXISTING BASE MATERIAL AS REQUIRED.
- ADJUST ALL STRUCTURE COVERS, INCLUDING GATE AND MONUMENT BOXES, TO THEIR FINISH ELEVATION.
- CLEAN PAVEMENT AND PLACE 1.5 INCH TOP COURSE HMA MIX (MAJOR STREETS) OVER ENTIRE STREET.
- CLEAN PAVEMENT AND PLACE HMA APPROACHES AS REQUIRED.
- CLEAN PAVEMENT AND COMPLETE ALL PAVEMENT MARKINGS.
- COMPLETE ALL MISCELLANEOUS CONSTRUCTION INCLUDING ALL CLEAN UP AND FINAL RESTORATION.
- REMOVE ALL TRAFFIC CONTROL DEVICES, AND MISS DIG FLAGS.

NOTES

FOR PROTECTION OF UNDERGROUND UTILITIES AND IN CONFORMANCE WITH PUBLIC ACT 174 OF 2013, THE CONTRACTOR SHALL CALL 811 OR 1-800-482-7171 A MINIMUM OF THREE FULL WORKING DAYS, EXCLUDING SATURDAYS, SUNDAYS, AND HOLIDAYS, PRIOR TO BEGINNING EACH EXCAVATION IN AREAS WHERE PUBLIC UTILITIES HAVE NOT BEEN PREVIOUSLY LOCATED. MEMBERS WILL THUS BE ROUTINELY NOTIFIED. THIS DOES NOT RELIEVE THE CONTRACTOR OF THE RESPONSIBILITY OF NOTIFYING UTILITY OWNERS WHO MAY NOT BE A PART OF THE "MISS DIG" ALERT SYSTEM.

THE UNDERGROUND LOCATIONS SHOWN FOR NATURAL GAS, TELEPHONE, ELECTRICAL POWER, CABLE TV AND FIBER OPTIC LINES ARE APPROXIMATE. THE CITY OF ANN ARBOR ASSUMES NO RESPONSIBILITY FOR THEIR ACCURATE REPRESENTATION IN THIS DRAWING. MISS DIG MUST BE CONTACTED PRIOR TO CONSTRUCTION TO LOCATE THESE UTILITIES.

THE IMPROVEMENTS COVERED BY THESE PLANS SHALL BE PERFORMED IN ACCORDANCE WITH MICHIGAN DEPARTMENT OF TRANSPORTATION (MDOT) 2012 STANDARD SPECIFICATIONS FOR CONSTRUCTION, INCLUDING REFERENCED MDOT PUBLICATIONS, AND THE PROJECT CONTRACT DOCUMENTS.

QUANTITIES			
Item Code	Item Description	Units	Quantity
2030011	Dr Structure, Rem	Ea	1.000
2030015	Sewer, Rem, Less than 24 inch	Ft	10.000
2047001	Curb, Gutter, and Curb and Gutter, Any Type, Rem	Ft	816.000
2047011	Sidewalk, Sidewalk Ramp, and Driveway Approach, Any Thickness, Rem	Syd	200.000
2057011	Grading, Driveway Approach	Syd	48.000
2057011	Grading, Sidewalk	Syd	105.000
2057011	Grading, Sidewalk Ramp	Syd	48.000
2057021	Subgrade Undercutting, Type IIA	Cyd	351.000
2087050	Erosion Control, Inlet Filter	Ea	6.000
4020987	Sewer, CI IV, 12 inch, Tr Det B	Ft	10.000
4030200	Dr Structure, 24 inch dia	Ea	1.000
4037050	Dr Structure Cover, Type B, Modified	Ea	23.000
4037050	Dr Structure Cover, Type K, Modified	Ea	1.000
4037050	Dr Structure, Adj, Case 1, Modified	Ea	41.000
4037050	Dr Structure, Temp Lowering, Modified	Ea	52.000
5010003	Cold Milling HMA Surface	Ton	1,818.000
5010005	HMA Surface, Rem	Syd	91.000
5010057	HMA, 5/3	Ton	1,784.000
5010061	HMA, Approach	Ton	34.000
6027021	Flowable Fill	Cyd	30.222
6030005	Cement	Ton	3.000
8017011	Driveway, Nonrein Conc, 6 inch, Modified	Syd	48.000
8027001	Curb and Gutter, Conc	Ft	752.000
8027001	Driveway Opening, Conc, Det M, Modified	Ft	70.000
8037001	Detectable Warning Surface, Modified	Ft	40.000
8037010	Sidewalk Ramp, Conc, 6 inch, Modified	Sft	430.000
8037010	Sidewalk with Integral Retaining Wall, 6 inch to 18 inch Height	Sft	45.000
8037010	Sidewalk with Integral Retaining Wall, Less than 6 inch Height	Sft	15.000
8037010	Sidewalk, Conc, 4 inch, Modified	Sft	890.000
8037010	Sidewalk, Conc, 6 inch, Modified	Sft	48.000
8110049	Pav Mrkg, Oly Cold Plastic, Direction Arrow Sym, Bike	Ea	10.000
8110058	Pav Mrkg, Oly Cold Plastic, Bike, Small Sym	Ea	10.000
8110153	Pav Mrkg, Sprayable Thermopl, 4 inch, White	Ft	447.000
8110154	Pav Mrkg, Sprayable Thermopl, 4 inch, Yellow	Ft	8,974.000
8110155	Pav Mrkg, Sprayable Thermopl, 6 inch, White	Ft	7,911.000
8110218	Pav Mrkg, Thermopl, 24 inch, Stop Bar	Ft	119.000
8117001	Pav Mrkg, Thermopl, 24 inch, Crosswalk	Ft	96.000
8117050	Pav Mrkg, Thermopl, Lt Turn Arrow Sym	Ea	3.000
8117050	Pav Mrkg, Thermopl, Only	Ea	3.000
8117050	Pav Mrkg, Thermopl, Rt Turn Arrow Sym	Ea	2.000
8120012	Barricade, Type III, High Intensity, Double Sided, Lighted, Furn	Ea	22.000
8120013	Barricade, Type III, High Intensity, Double Sided, Lighted, Oper	Ea	22.000
8120140	Lighted Arrow, Type C, Furn	Ea	3.000
8120141	Lighted Arrow, Type C, Oper	Ea	3.000
8120260	Plastic Drum, High Intensity, Lighted, Furn	Ea	225.000
8120261	Plastic Drum, High Intensity, Lighted, Oper	Ea	225.000
8120330	Sign, Portable, Changeable Message, Furn	Ea	1.000
8120331	Sign, Portable, Changeable Message, Oper	Ea	1.000
8120350	Sign, Type B, Temp, Prismatic, Furn	Sft	792.500
8120351	Sign, Type B, Temp, Prismatic, Oper	Sft	792.500
8127050	No Parking Sign	Ea	80.000
8167011	Slope Restoration	Syd	300.000
8217050	Monument Box Adjust	Ea	3.000
8230431	Gate Box, Adj, Case 1	Ea	12.000

CONSTRUCTION KEY	
KEY	ASSOCIATED PAY ITEM(S)
AA	• Dr Structure, Adj, Case 1, Modified • Dr Structure, Adj, Case 2, Modified • Dr Structure, Temp Lowering, Modified
AB	• Dr Structure, Temp Lowering, Modified • Gate Box, Adj, Case 1 • Gate Box, Adj, Case 2 • Monument Box Adjust
ADST	• Dr Structure, Adj, Add Depth, Modified
AK	• Dr Structure, Adj, Case 1, Modified
C4	• Sidewalk, Sidewalk Ramp, and Driveway Approach, Any Thickness, Rem • Grading, Sidewalk • Sidewalk, Conc, 4 inch, Modified
C4HE	• Sidewalk, Sidewalk Ramp, and Driveway Approach, Any Thickness, Rem • Grading, Sidewalk • Cement • Sidewalk, Conc, 4 inch, Modified
C6	• Sidewalk, Sidewalk Ramp, and Driveway Approach, Any Thickness, Rem • Grading, Sidewalk • Sidewalk Ramp • Detectable Warning Surface, Modified • Sidewalk Ramp, Conc, 6 inch, Modified • Sidewalk, Conc, 6 inch, Modified
C8	• Grading, Driveway Approach • Driveway, Nonrein Conc, 8 inch, Modified
C HE	• Sidewalk, Sidewalk Ramp, and Driveway Approach, Any Thickness, Rem • Grading, Driveway Approach • Grading, Sidewalk • Grading, Sidewalk Ramp • Cement • Driveway, Nonrein Conc, 6 inch, Modified • Driveway, Nonrein Conc, 8 inch, Modified • Detectable Warning Surface, Modified • Sidewalk Ramp, Conc, 6 inch, Modified • Sidewalk, Conc, 6 inch, Modified
C/G	• Curb, Gutter, and Curb and Gutter, Any Type, Rem • Curb and Gutter, Conc
C/GHE	• Curb, Gutter, and Curb and Gutter, Any Type, Rem • Cement • Driveway Opening, Conc, Det M, Modified
CP	• Grading, Sidewalk • Sidewalk, Conc, 4 inch, Modified
CR	• Sidewalk, Sidewalk Ramp, and Driveway Approach, Any Thickness, Rem • Dr Structure, Rem
DS	• Sewer, Rem, Less than 24 inch • Dr Structure, 24 inch dia • Dr Structure, Rem
DSDI	• Sewer, Rem, Less than 24 inch • Dr Structure, Double Inlet
PT	• Dr Structure, Point
RRA	• Dr Structure Cover, Type B • Dr Structure Cover, Type B, Special • Dr Structure, Adj, Case 1, Modified • Dr Structure, Temp Lowering, Modified
RRK	• Dr Structure Cover, Type K • Dr Structure, Adj, Case 1, Modified
RS	• Dr Structure, Reconstruct
TYPE I	• Plastic Drum, High Intensity, Lighted, Furn • Plastic Drum, High Intensity, Lighted, Oper
TYPE II	• Barricade, Type III, High Intensity, Double Sided, Lighted, Furn • Barricade, Type III, High Intensity, Double Sided, Lighted, Oper

LEGEND	
SYMBOL	DESCRIPTION
⊙	EXISTING SANITARY SEWER MANHOLE
⊕	EXISTING STORM SEWER MANHOLE
⊗	EXISTING WATER MAIN VALVE IN WELL
+	WATER MAIN GATE VALVE IN BOX
⊕	FIRE HYDRANT
⊙	MICHCON GAS CO. VALVE BOX/WELL
⊕	AMERITECH TELEPHONE VAULT
⊙	ELECTRIC MANHOLE
⊕	SOIL BORING
□	EXISTING STORM SEWER INLET
□	MONUMENT BOX
▬	REMOVE AND REPLACE CONC. SIDEWALK
▬	PLACE CONCRETE SIDEWALK
▬	REMOVE & REPLACE CONC. CURB & GUTTER
▬	CONSTRUCTION LIMITS
▬	6" WRAPPED UNDERDRAIN
▬	REMOVE CONCRETE SIDEWALK
▬	SUBGRADE UNDERCUT

QUANTITIES				
Sign, Type B, Temp, Prismatic				
Quantity	Sign Code	Description	Area (sft)	Total
67.0	D3-1	Street Name Sign	4.000	268.000
1.0	M4-10L	Detour Arrow Sign	6.000	6.000
1.0	M4-8a	End Detour Sign	3.000	3.000
3.0	M4-9L	Detour Sign (w/Left Arrow)	5.000	15.000
3.0	M4-9R	Detour Sign (w/Right Arrow)	5.000	15.000
5.0	M4-9S	Detour Sign (w/Thru Arrow)	5.000	25.000
1.0	R11-2	Road Closed Sign ("Road Closed")	10.000	10.000
1.0	R11-4	Road Closed Sign ("Road Closed To Thru Traffic")	12.500	12.500
1.0	R3-1	Movement Prohibition Sign ("No Right Turn")	4.000	4.000
1.0	R3-2	Movement Prohibition Sign ("No Left Turn")	4.000	4.000
2.0	R3-8	Advance Intersection Lane Control Sign (Left Turn Only or Right Turn Only)	7.500	15.000
2.0	R3-8	Advance Intersection Lane Control Sign (Thru Only or Right Turn Only)	7.500	15.000
18.0	R6-1 L	One Way (Left) Sign	3.000	54.000
21.0	R6-1 R	One Way (Right) Sign	3.000	63.000
2.0	SP-1	Special Sign	20.000	40.000
21.0	W20-1	Road Work Ahead Sign	9.000	189.000
3.0	W20-2	Detour Ahead Sign	9.000	27.000
3.0	W20-3	Road Closed Ahead Sign	9.000	27.000
		TOTAL		792.50



PROJECT MANAGEMENT SERVICES UNIT
CITY OF ANN ARBOR PUBLIC SERVICES
301 EAST HURON STREET, P.O. BOX 8647
ANN ARBOR, MICHIGAN 48107-8647
734-794-6410 www.a2gov.org

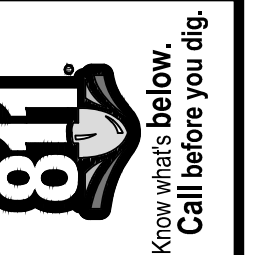

S:\Project Management\Drafting\autocad\2016004\Plan Production\2016004-DEXTER AVE.dwg Dwg Created: 24-Nov-15 15:02 standard bw.stb - Plot Date: 15-Mar-16



TRAFFIC CONTROL SIGN		
TAG	SIGN	NUM.
1		D3-1 M4-9S 30x24
2		D3-1 M4-9R 30x24
3		D3-1 M4-9L 30x24
6		D3-1 M4-8a 24x18
7		R11-4 60x30
8		SPECIAL 48x60
9		SPECIAL 48x60
10		W20-2 36"x36" D3-1
11		W20-3 36"x36" D3-1
12		W20-1 36"x36" D3-1
13		R11-4 60x30



REV.	DATE	DESCRIPTION
02	3-15-2016	ADDENDUM #3
01	3-7-2016	ADDENDUM #1
00	2-22-2016	BID SET

CITY OF ANN ARBOR
PUBLIC SERVICES
301 EAST HURON STREET
PO BOX 8647
ANN ARBOR MI 4810-8647
www.a2gov.org



PROJECT MANAGEMENT - PUBLIC SERVICES - CITY OF ANN ARBOR
STREET RESURFACING - 2016
DEXTER AVENUE
DETOUR

S:\Project Management\Drafting\autocad\2016004\Plan Production\2016004-DEXTER AVE.dwg Dwg Created: 24-Nov-15 - _a2 standard bw.stb - Plot Date: 15-Mar-16

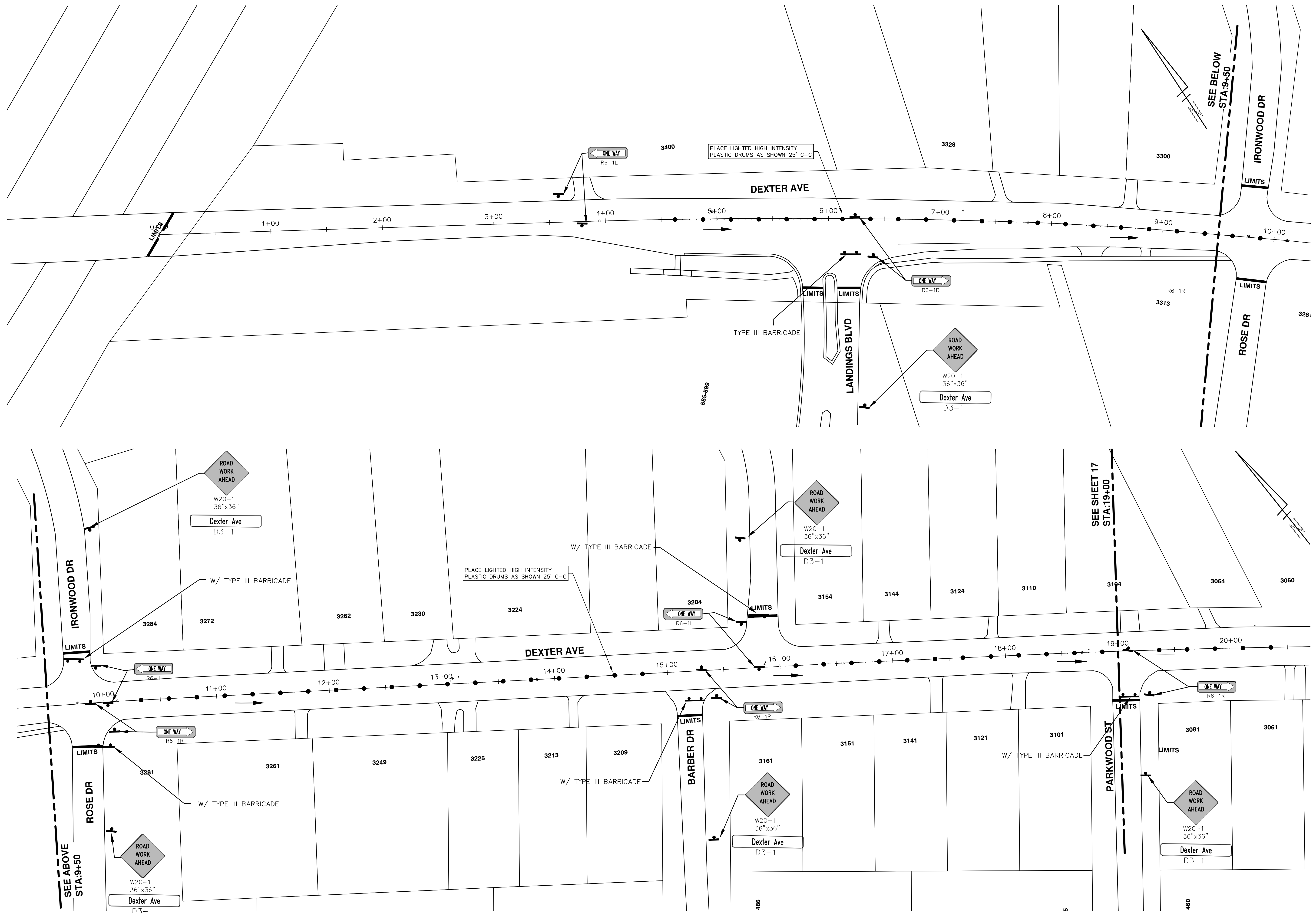

Know what's below.
Call Before you dig.

REV.	DESCRIPTION	DATE	DRAWN	CHECKED
02	ADDENDUM #3	3-15-2016	DAD	DAD
01	ADDENDUM #1	3-7-2016	DAD	DAD
00	BID SET	2-22-2016	GS AH JK	DAD

CITY OF ANN ARBOR
PUBLIC SERVICES
301 EAST HURON STREET
ANN ARBOR MI 48106-8647
www.a2gov.org



PROJECT MANAGEMENT - PUBLIC SERVICES - CITY OF ANN ARBOR
STREET RESURFACING - 2016
DEXTER AVENUE
TRAFFIC CONTROL

SCALE PLAN: 1" = 40'
DRAWING No. 2016004-16

S:\Project Management\Drafting\autocad\2016004\Plan Production\2016004-DEXTER AVE.dwg Dwg Created: 24-Nov-15 - _a2 standard bw.stb - Plot Date: 15-Mar-16

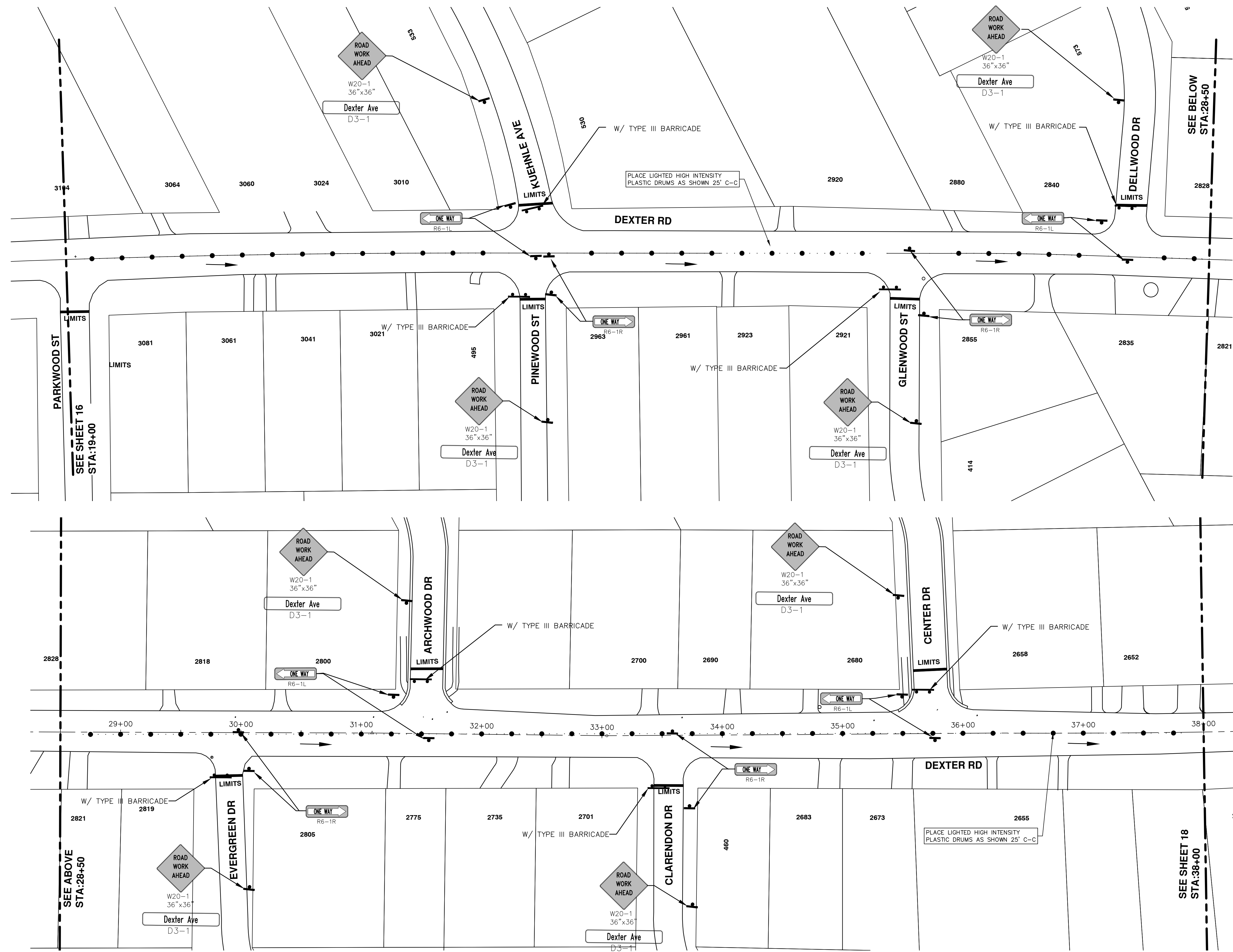

SEE SHEET 16
STA:19+00

SEE ABOVE
STA:28+50

SEE SHEET 18
STA:39+00

PROJECT MANAGEMENT - PUBLIC SERVICES - CITY OF ANN ARBOR
STREET RESURFACING - 2016
DEXTER AVENUE
TRAFFIC CONTROL

SCALE PLAN: #####
DRAWING No. 2016004-17

811
Know what's below.
Call before you dig.

REV.	DESCRIPTION	DATE	DRAWN	CHECKED
02	ADDENDUM #3	3-15-2016	DAD	DAD
01	ADDENDUM #1	3-7-2016	DAD	DAD
00	BID SET	2-22-2016	GS AH JK	DAD

CITY OF ANN ARBOR
PUBLIC SERVICES
301 EAST HURON STREET
ANN ARBOR MI 48106-8647
www.a2gov.org

CITY OF ANN ARBOR
MI CHIT

S:\Project Management\Drafting\autocad\2016004\Plan Production\2016004-DEXTER AVE.dwg Dwg Created: 24-Nov-15 - _a2 standard bw.stb - Plot Date: 15-Mar-16

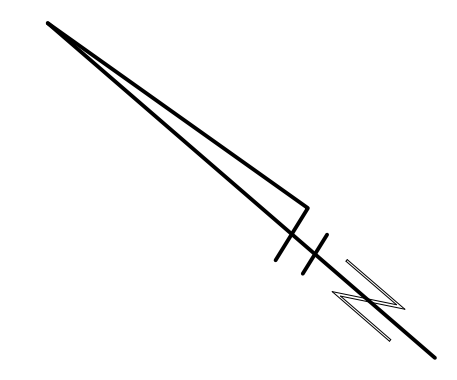
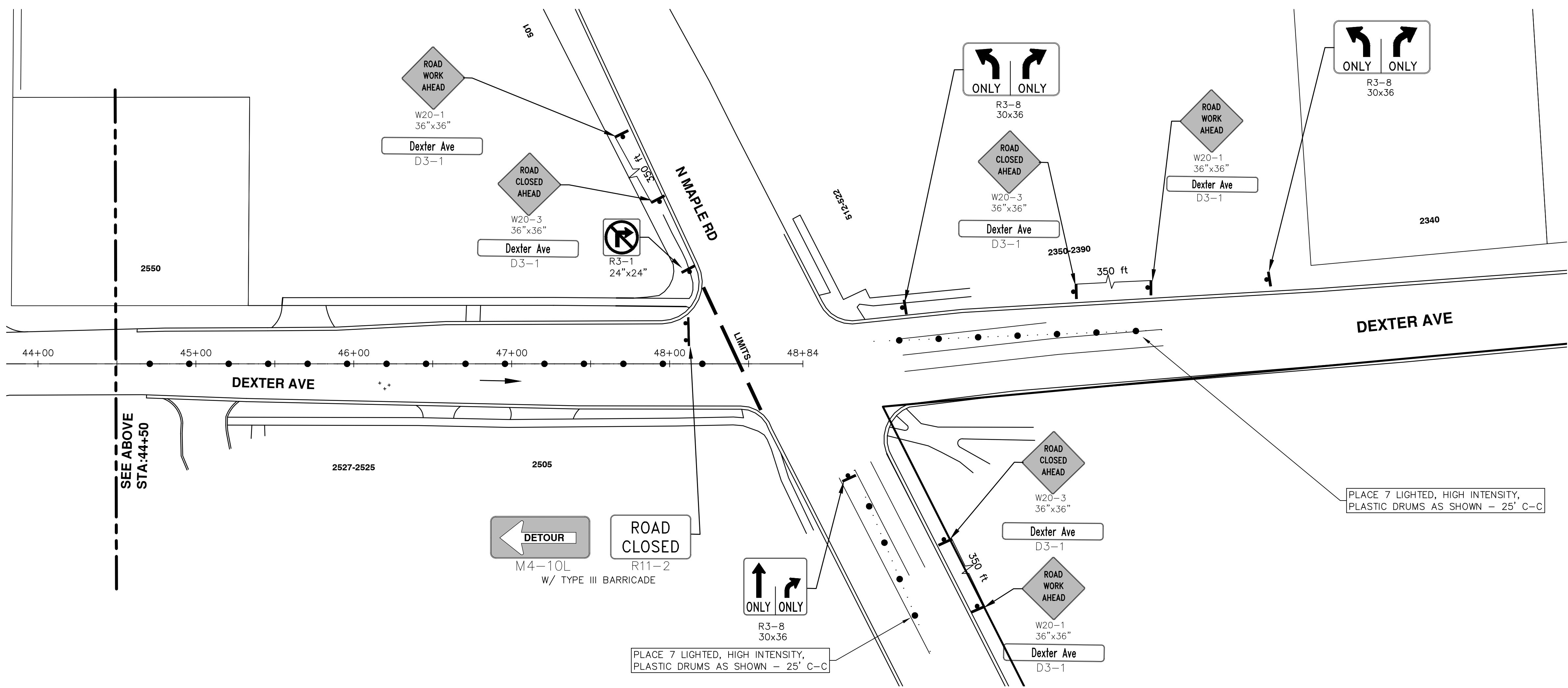
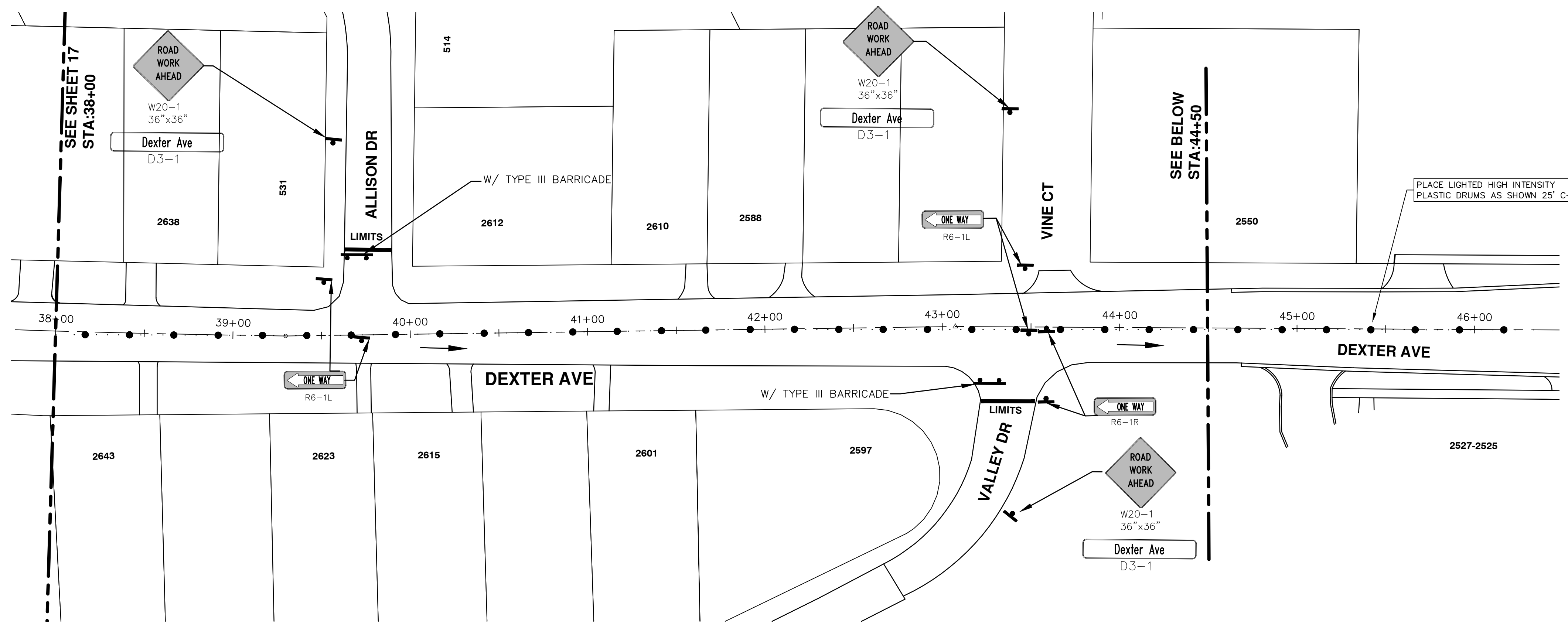

PROJECT MANAGEMENT - PUBLIC SERVICES - CITY OF ANN ARBOR
STREET RESURFACING - 2016
 DEXTER AVENUE
 TRAFFIC CONTROL

SCALE PLAN: 1" = 40'
 DRAWING No. 2016004-18
 SHEET No. 18 OF 98



CITY OF ANN ARBOR
 PUBLIC SERVICES
 301 EAST HURON STREET
 ANN ARBOR, MI 48106-8647
 www.a2gov.org

REV.	DATE	DESCRIPTION	DRAWN	CHECKED
02	3-15-2016	ADDENDUM #3	DAD	DAD
01	3-7-2016	ADDENDUM #1	DAD	DAD
00	2-22-2016	BID SET	ISS AH UK	DAD



Know what's below.
Call Before you dig.

S:\Project Management\Drafting\autocad\2016004\Plan Production\2016004-DEXTER AVE.dwg Dwg Created: 24-Nov-15 - _a2 standard bw.stb - Plot Date: 15-Mar-16

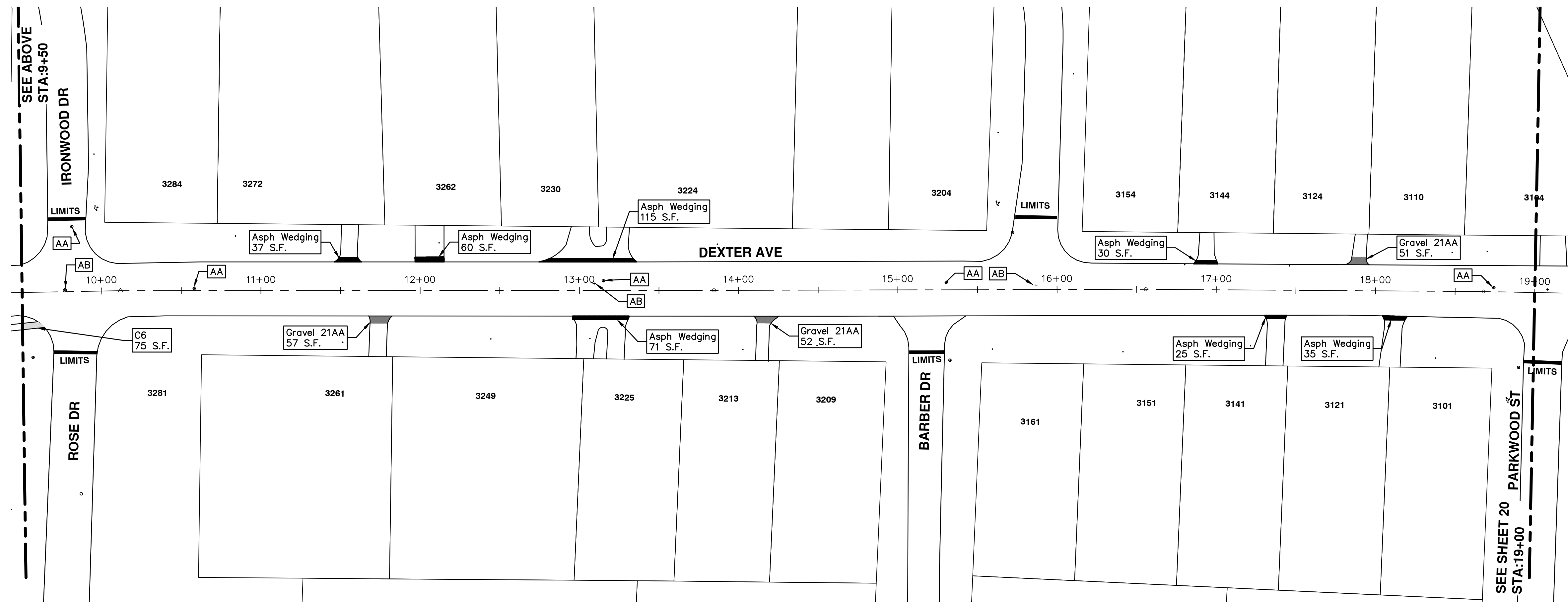
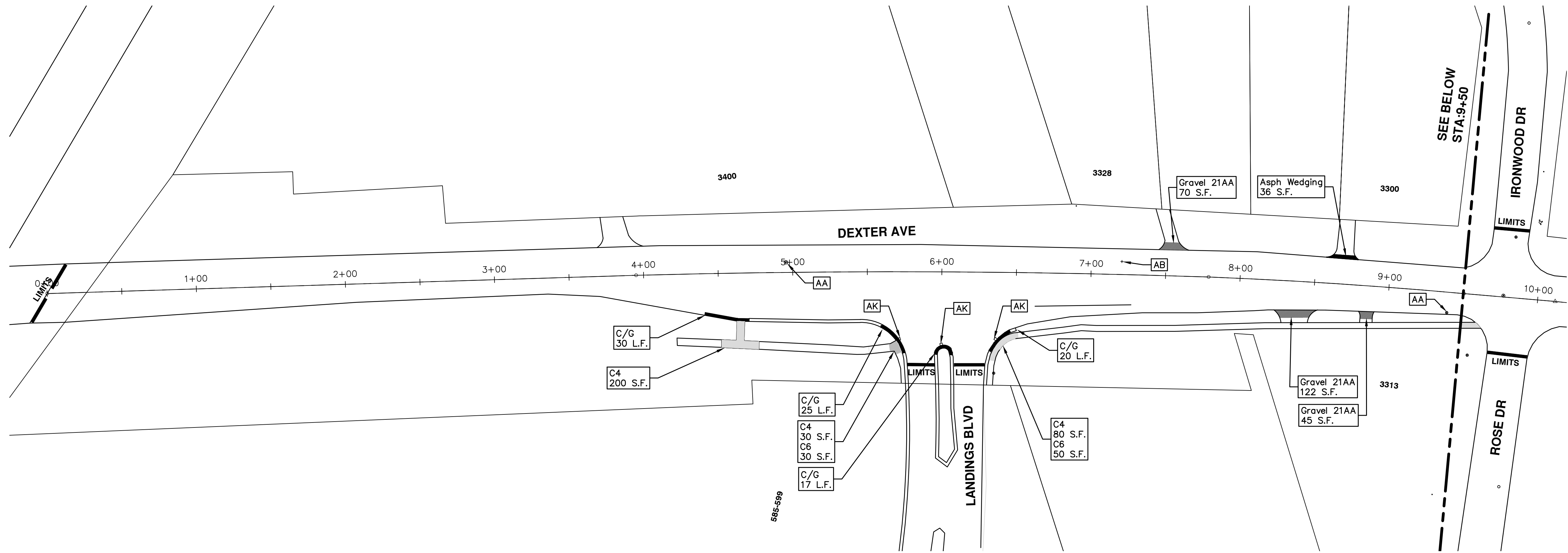

REV.	DESCRIPTION	DATE	DRAWN	CHECKED
02	ADDENDUM #3	3-15-2016	DAD	DAD
01	ADDENDUM #1	3-7-2016	DAD	DAD
00	BID SET	2-22-2016	SS AH JK	DAD

CITY OF ANN ARBOR
PUBLIC SERVICES
301 EAST HURON STREET
ANN ARBOR MI 48106-8647
www.a2gov.org



PROJECT MANAGEMENT - PUBLIC SERVICES - CITY OF ANN ARBOR
STREET RESURFACING - 2016
DEXTER AVENUE
RESURFACING

SCALE PLAN: 1" = 40'
DRAWING No. 2016004-19

S:\Project Management\Drafting\autocad\2016004\Plan Production\2016004-DEXTER AVE.dwg Dwg Created: 24-Nov-15 - _a2 standard bw.stb - Plot Date: 15-Mar-16

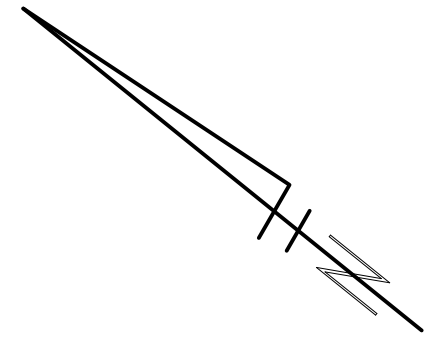
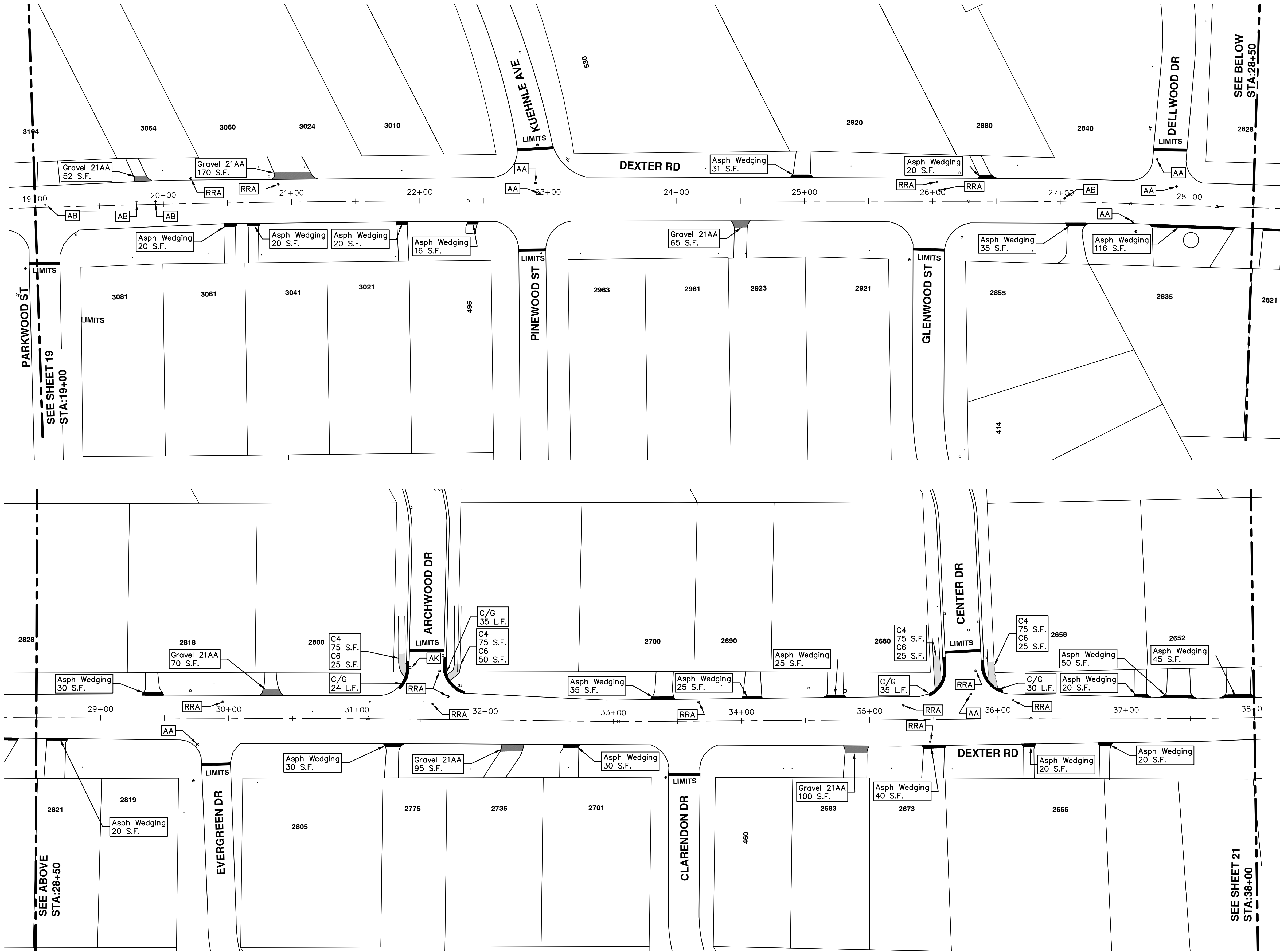

PROJECT MANAGEMENT - PUBLIC SERVICES - CITY OF ANN ARBOR
STREET RESURFACING - 2016
DEXTER AVENUE
RESURFACING

SCALE PLAN: 1" = 40'
DRAWING No. 2016004-20

811
Know what's below.
Call Before you dig.

REV.	DESCRIPTION	DATE	DRAWN	CHECKED
02	ADDENDUM #3	3-15-2016	DAD	DAD
01	ADDENDUM #1	3-7-2016	DAD	DAD
00	BID SET	2-22-2016	GS AH UK	DAD

CITY OF ANN ARBOR
PUBLIC SERVICES
301 EAST HURON STREET
ANN ARBOR MI 48106-6647
www.aagov.org

CITY OF ANN ARBOR MICHIGAN

S:\Project Management\Drafting\autocad\2016004\Plan Production\2016004-DEXTER AVE.dwg Dwg Created: 24-Nov-15 - _a2 standard bw.stb - Plot Date: 15-Mar-16

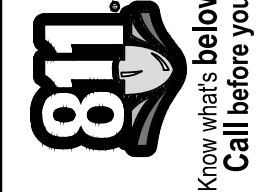
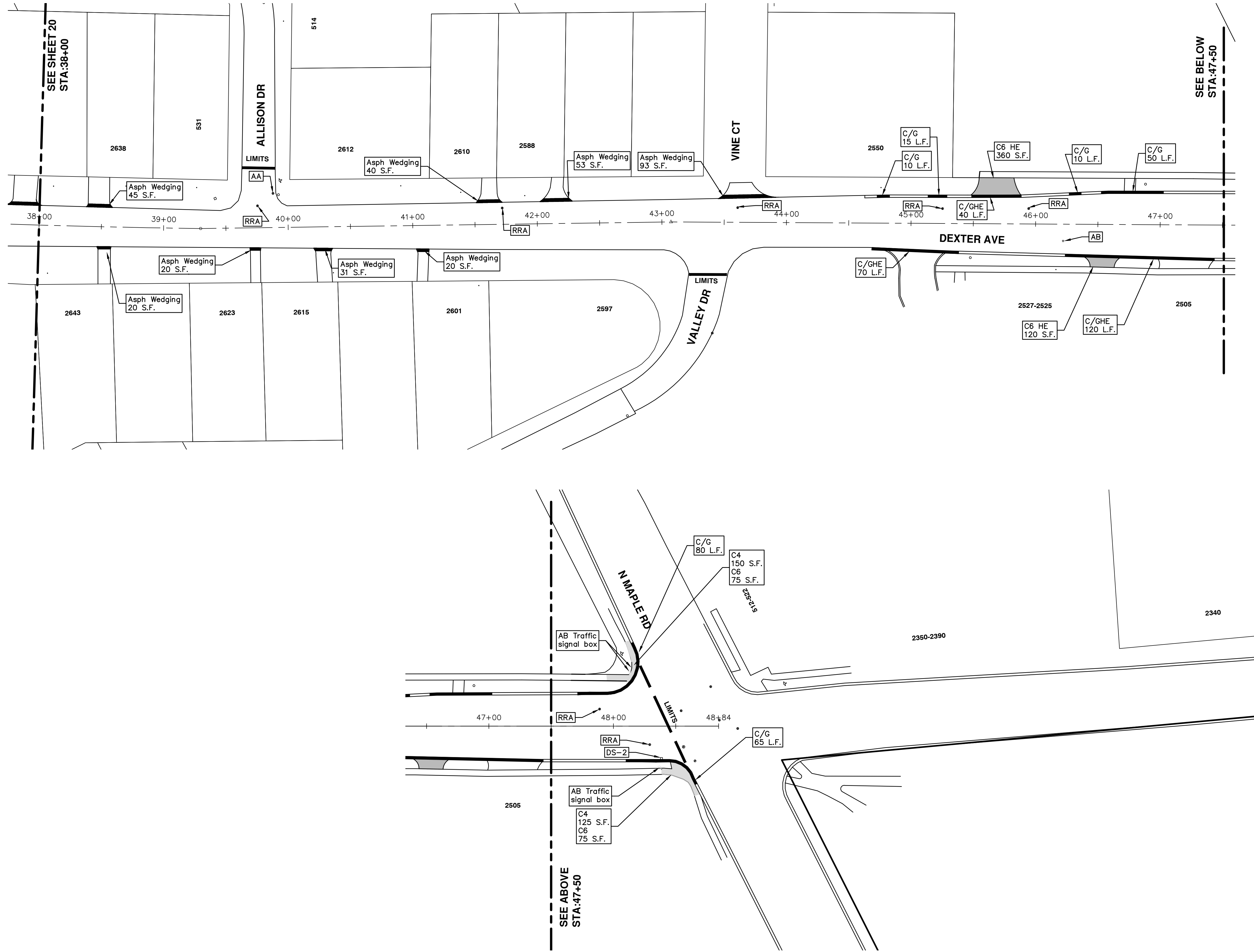

REV.	DESCRIPTION	DATE	DRAWN	CHECKED
02	ADDENDUM #3	3-15-2016	DAD	DAD
01	ADDENDUM #1	3-7-2016	DAD	DAD
00	BID SET	2-22-2016	GS AH JK	DAD

CITY OF ANN ARBOR
 PUBLIC SERVICES
 301 EAST HURON STREET
 P.O. BOX 8647
 ANN ARBOR MI 48108-8647
 www.a2gov.org



PROJECT MANAGEMENT - PUBLIC SERVICES - CITY OF ANN ARBOR
STREET RESURFACING - 2016
 DEXTER AVENUE
 RESURFACING

SCALE PLAN: 1" = 40'
 DRAWING No. 2016004-21

S:\Project Management\Drafting\autocad\2016004\Plan Production\2016004-DEXTER AVE.dwg Dwg Created: 24-Nov-15 - _a2 standard bw.stb - Plot Date: 15-Mar-16

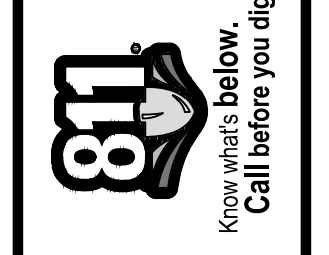
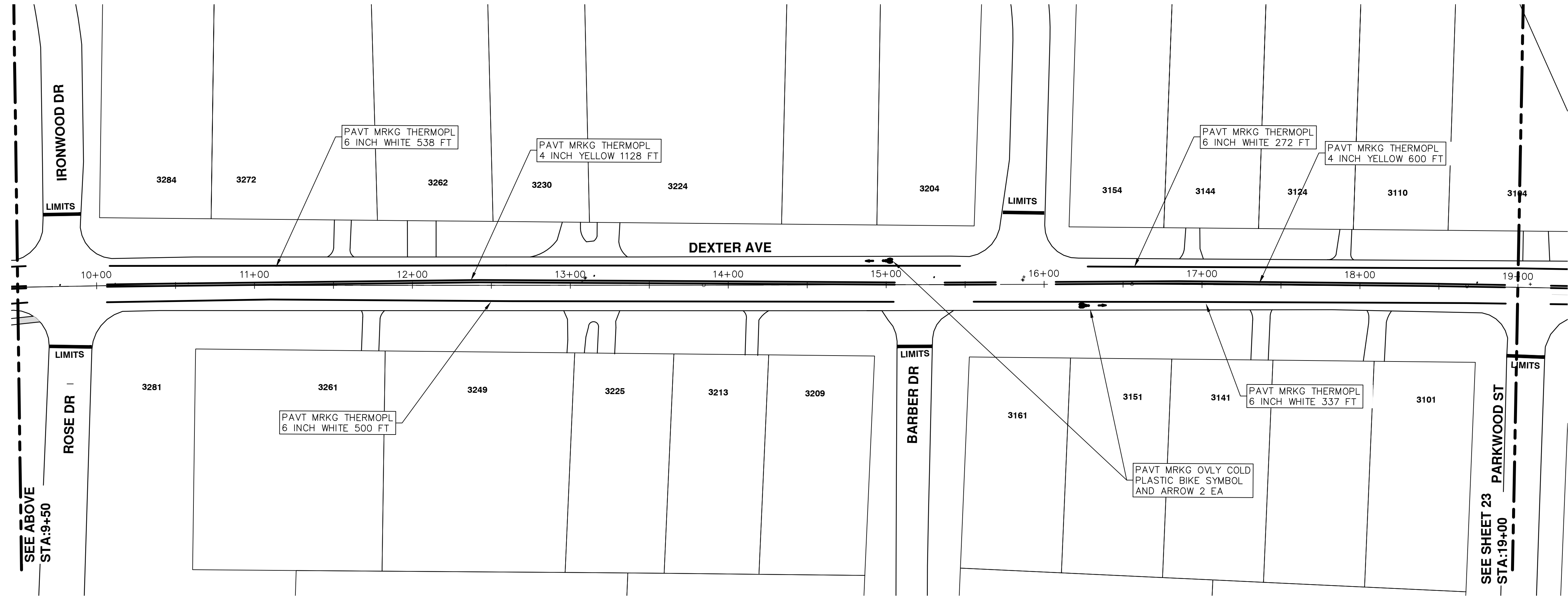
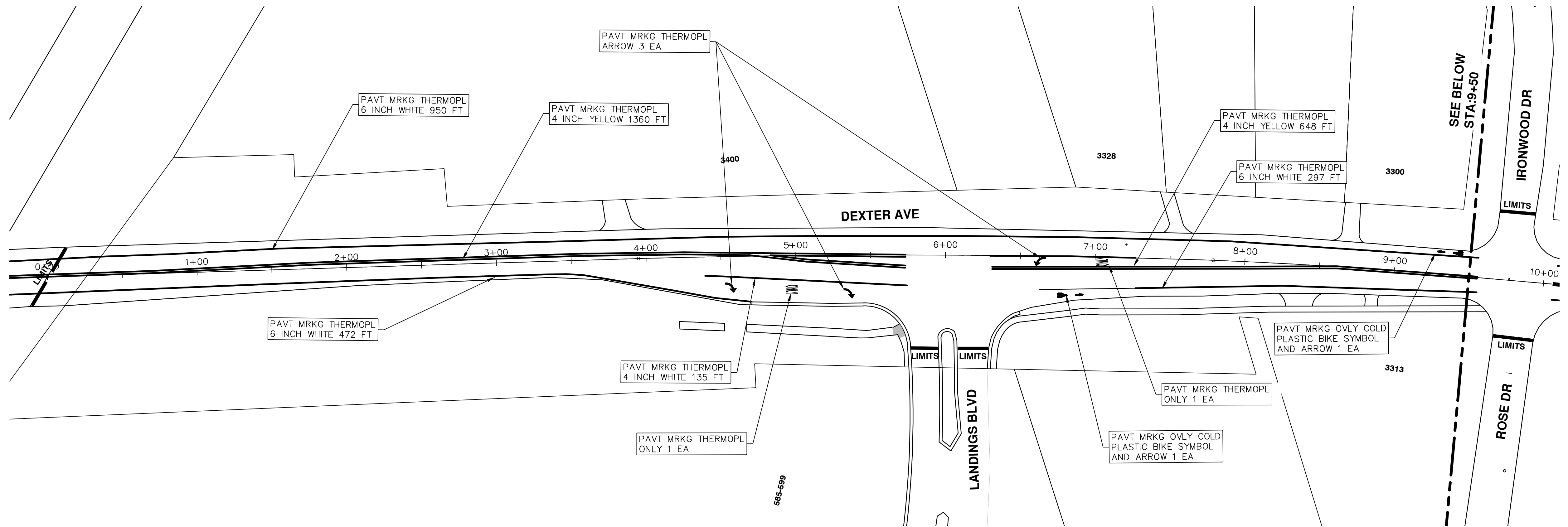

REV.	DESCRIPTION	DATE	DRAWN	CHECKED
02	ADDENDUM #3	3-15-2016	DAD	DAD
01	ADDENDUM #1	3-7-2016	DAD	DAD
00	BID SET	2-22-2016	ISS AH JK	DAD

CITY OF ANN ARBOR
PUBLIC SERVICES
301 EAST HURON STREET
ANN ARBOR MI 48106-8647
www.a2gov.org



PROJECT MANAGEMENT - PUBLIC SERVICES - CITY OF ANN ARBOR
STREET RESURFACING - 2016
DEXTER AVENUE
PAVEMENT MARKINGS

SCALE PLAN: 1" = 40'
DRAWING No. 2016004-22

S:\Project Management\Drafting\autocad\2016004\Plan Production\2016004-DEXTER AVE.dwg Dwg Created: 24-Nov-15 - _a2 standard bw.stb - Plot Date: 15-Mar-16

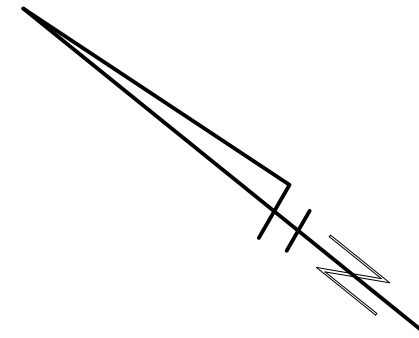
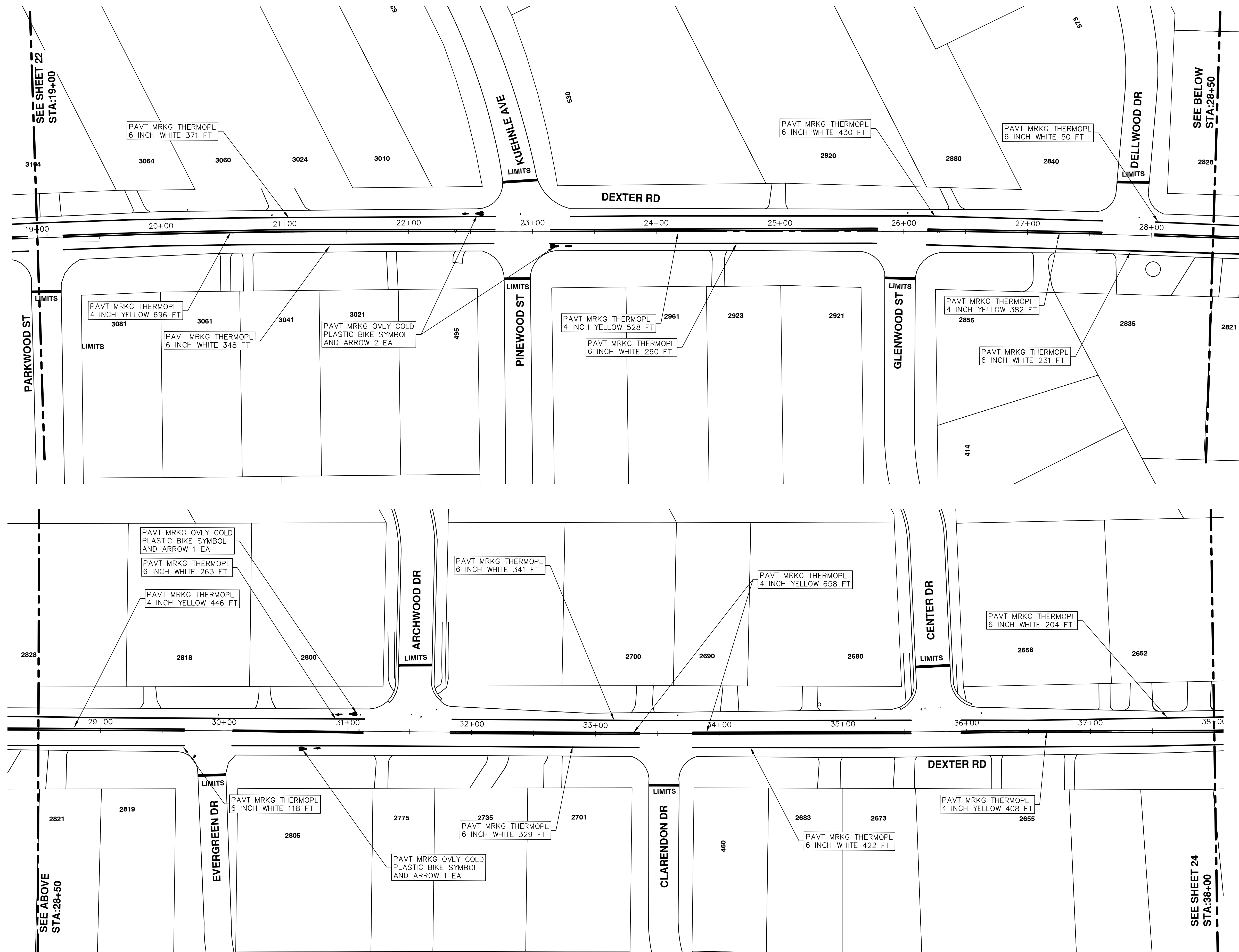

REV.	DESCRIPTION	DATE	DRAWN	CHECKED
02	ADDENDUM #3	3-15-2016	DAD	DAD
01	ADDENDUM #1	3-7-2016	DAD	DAD
00	BID SET	2-22-2016	SS AH JK	DAD

CITY OF ANN ARBOR
 PUBLIC SERVICES
 301 EAST HURON STREET
 P.O. BOX 8647
 ANN ARBOR MI 4810-8647
 www.a2gov.org



PROJECT MANAGEMENT - PUBLIC SERVICES - CITY OF ANN ARBOR
STREET RESURFACING - 2016
 DEXTER AVENUE
 PAVEMENT MARKINGS

SCALE PLAN: 1" = 40'
 DRAWING No. 2016004-23

S:\Project Management\Drafting\autocad\2016004\Plan Production\2016004-DEXTER AVE.dwg Dwg Created: 24-Nov-15 - _a2 standard bw.stb - Plot Date: 15-Mar-16

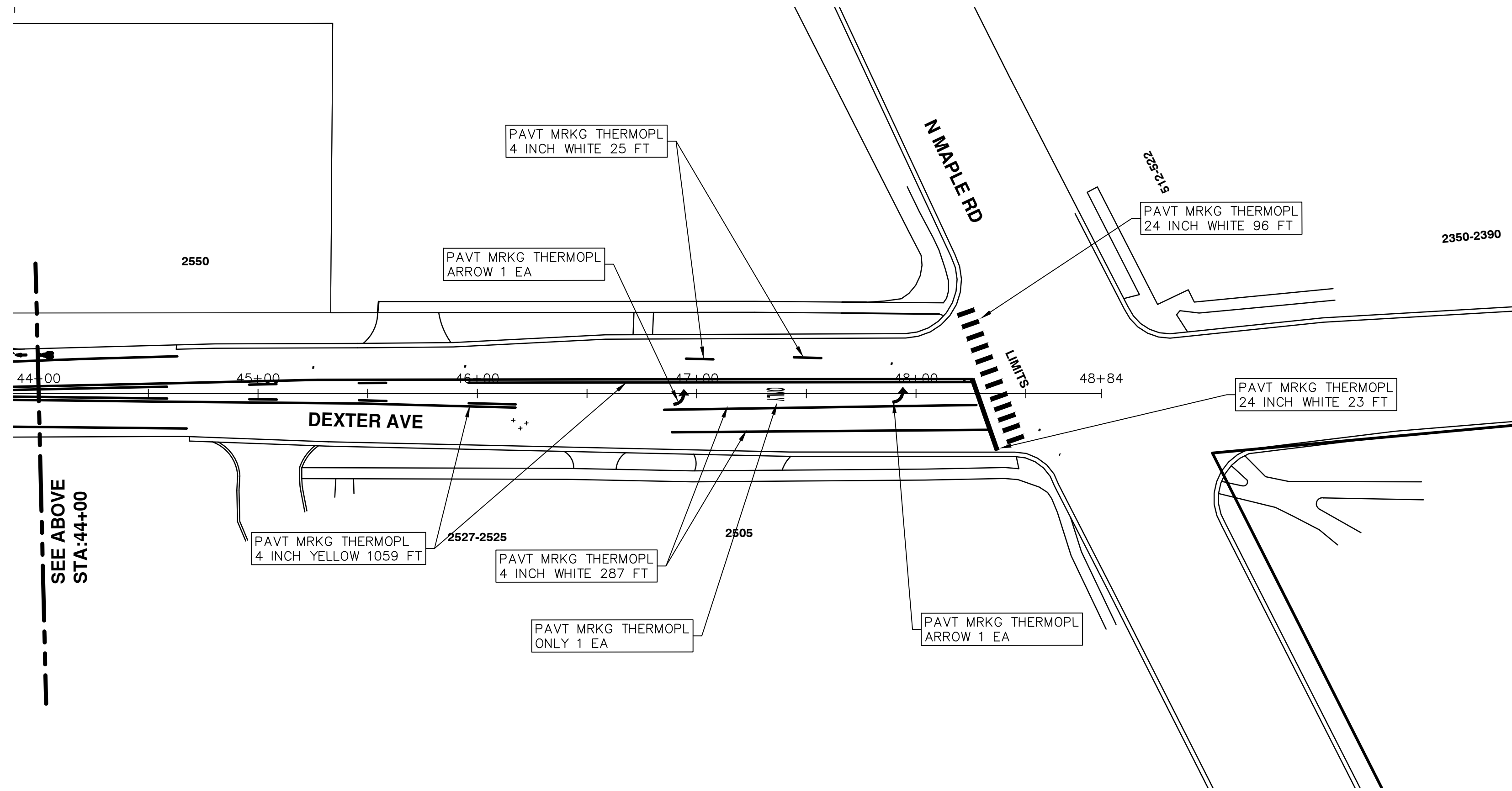
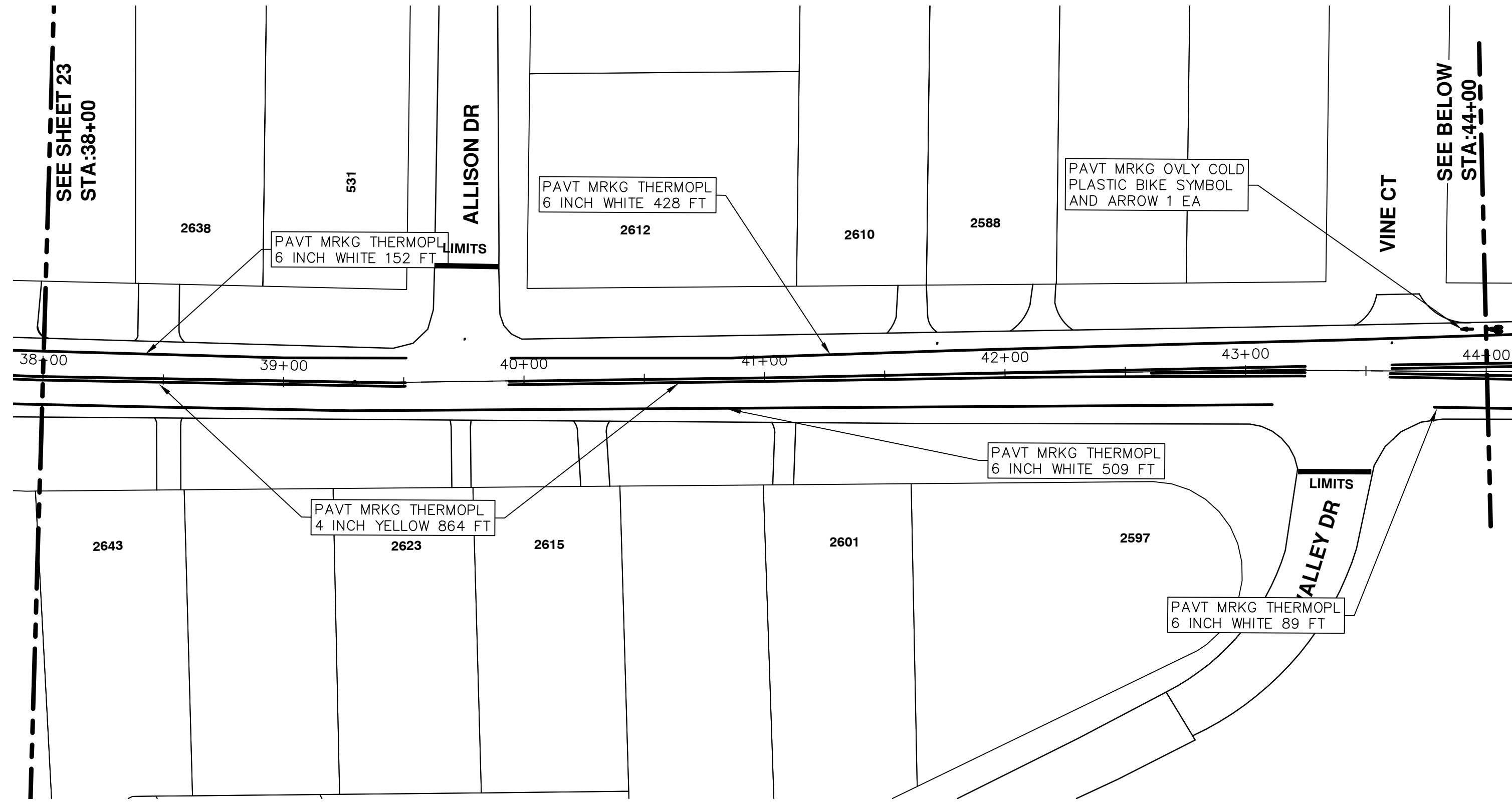

REV.	DESCRIPTION	DATE	DRAWN	CHECKED
02	ADDENDUM #3	3-15-2016	DAD	DAD
01	ADDENDUM #1	3-7-2016	DAD	DAD
00	BID SET	2-22-2016	SS AH JK	DAD

CITY OF ANN ARBOR
 PUBLIC SERVICES
 301 EAST HURON STREET
 ANN ARBOR, MI 48106-8647
 www.a2gov.org

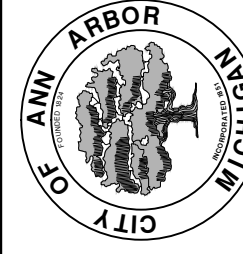

PROJECT MANAGEMENT - PUBLIC SERVICES - CITY OF ANN ARBOR
STREET RESURFACING - 2016
 DEXTER AVENUE
 PAVEMENT MARKINGS

SCALE PLAN: 1" = 40'
 DRAWING No. 2016004-24



CITY OF ANN ARBOR PROJECT MANAGEMENT STREET RESURFACING - 2016 LOCATION: DHU VARREN ROAD

ITB No. 4422 FILE No. 2016004



S:\Project Management\Drafting\autocad\2016004\Plan Production\2016004-DHU VARREN RD.dwg Dwg Created: 24-Nov-15 - _a2 standard bw.stb - Plot Date: 15-Mar-16

QUANTITIES			
Item Code	Item Description	Units	Quantity
2047001	Curb, Gutter, and Curb and Gutter, Any Type, Rem	Ft	190.000
2057011	Grading, Sidewalk	Syd	17.000
2057011	Grading, Sidewalk Ramp	Syd	45.000
2057021	Subgrade Undercutting, Type IIA	Cyd	157.000
2087050	Erosion Control, Inlet Filter	Ea	9.000
4037050	Dr Structure, Adj, Case 1, Modified	Ea	3.000
4037050	Dr Structure, Point	Ea	1.000
5010003	Cold Milling HMA Surface	Ton	826.000
5010005	HMA Surface, Rem	Syd	22.000
5010057	HMA, 5E3	Ton	798.000
5010061	HMA, Approach	Ton	28.000
5017050	HMA Surface, Around Structure Cover, Rem	Ea	19.000
6027021	Flowable Fill	Cyd	7.037
8027001	Curb and Gutter, Conc	Ft	196.000
8037001	Detectable Warning Surface, Modified	Ft	40.000
8037010	Sidewalk Ramp, Conc, 6 inch, Modified	Sft	400.000
8037010	Sidewalk, Conc, 4 inch, Modified	Sft	150.000
8110049	Pav Mrkg, Only Cold Plastic, Direction Arrow Sym, Bike	Ea	4.000
8110058	Pav Mrkg, Only Cold Plastic, Bike, Small Sym	Ea	4.000
8110154	Pav Mrkg, Sprayable Thermopl, 4 inch, Yellow	Ft	5,454.000
8110155	Pav Mrkg, Sprayable Thermopl, 6 inch, White	Ft	4,697.000
8110197	Pav Mrkg, Thermopl, 6 inch, Crosswalk	Ft	152.000
8110218	Pav Mrkg, Thermopl, 24 inch, Stop Bar	Ft	64.000
8117001	Pav Mrkg, Thermopl, 24 inch, Crosswalk	Ft	104.000
8117050	Pav Mrkg, Thermopl, Railroad Sym	Ea	1.000
8120012	Barricade, Type III, High Intensity, Double Sided, Lighted, Furn	Ea	8.000
8120013	Barricade, Type III, High Intensity, Double Sided, Lighted, Oper	Ea	8.000
8120140	Lighted Arrow, Type C, Furn	Ea	1.000
8120141	Lighted Arrow, Type C, Oper	Ea	1.000
8120260	Plastic Drum, High Intensity, Lighted, Furn	Ea	105.000
8120261	Plastic Drum, High Intensity, Lighted, Oper	Ea	105.000
8120330	Sign, Portable, Changeable Message, Furn	Ea	1.000
8120331	Sign, Portable, Changeable Message, Oper	Ea	1.000
8120350	Sign, Type B, Temp, Prismatic, Furn	Sft	313.500
8120351	Sign, Type B, Temp, Prismatic, Oper	Sft	313.500
8127050	No Parking Sign	Ea	37.000
8167011	Slope Restoration	Syd	70.000

CONSTRUCTION KEY	
KEY	ASSOCIATED PAY ITEM(S)
AA	• Dr Structure, Adj, Case 1, Modified • Dr Structure, Adj, Case 2, Modified • Dr Structure, Temp Lowering, Modified
AB	• Dr Structure, Temp Lowering, Modified • Gate Box, Adj, Case 1 • Gate Box, Adj, Case 2 • Monument Box Adjust
ADST	• Dr Structure, Adj, Add Depth, Modified
AK	• Dr Structure, Adj, Case 1, Modified
C4	• Sidewalk, Sidewalk Ramp, and Driveway Approach, Any Thickness, Rem • Grading, Sidewalk • Sidewalk, Conc, 4 inch, Modified
C4HE	• Sidewalk, Sidewalk Ramp, and Driveway Approach, Any Thickness, Rem • Grading, Sidewalk • Cement • Sidewalk, Conc, 4 inch, Modified
C6	• Sidewalk, Sidewalk Ramp, and Driveway Approach, Any Thickness, Rem • Grading, Sidewalk • Grading, Sidewalk Ramp • Detectable Warning Surface, Modified • Sidewalk Ramp, Conc, 6 inch, Modified • Sidewalk, Conc, 6 inch, Modified
C8	• Grading, Driveway Approach • Driveway, Nonreinf Conc, 8 inch, Modified • Sidewalk, Sidewalk Ramp, and Driveway Approach, Any Thickness, Rem • Grading, Driveway Approach • Grading, Sidewalk • Grading, Sidewalk Ramp
CHE	• Cement • Driveway, Nonreinf Conc, 6 inch, Modified • Driveway, Nonreinf Conc, 8 inch, Modified • Detectable Warning Surface, Modified • Sidewalk Ramp, Conc, 6 inch, Modified • Sidewalk, Conc, 6 inch, Modified
C/G	• Curb, Gutter, and Curb and Gutter, Any Type, Rem • Curb and Gutter, Conc
C/GHE	• Curb, Gutter, and Curb and Gutter, Any Type, Rem • Cement • Driveway Opening, Conc, Det M, Modified
CP	• Grading, Sidewalk • Sidewalk, Conc, 4 inch, Modified
CR	• Sidewalk, Sidewalk Ramp, and Driveway Approach, Any Thickness, Rem • Dr Structure, Rem
DS	• Sewer, Rem, Less than 24 inch • Dr Structure, 24 inch dia • Dr Structure, Rem
DSDI	• Sewer, Rem, Less than 24 inch • Dr Structure, Double Inlet
PT	• Dr Structure, Point
RRA	• Dr Structure Cover, Type B • Dr Structure Cover, Type B, Special • Dr Structure, Adj, Case 1, Modified • Dr Structure, Temp Lowering, Modified
RRK	• Dr Structure Cover, Type K • Dr Structure, Adj, Case 1, Modified
RS	• Dr Structure, Reconstruct
TYPE I	• Plastic Drum, High Intensity, Lighted, Furn • Plastic Drum, High Intensity, Lighted, Oper
TYPE II	• Barricade, Type III, High Intensity, Double Sided, Lighted, Furn • Barricade, Type III, High Intensity, Double Sided, Lighted, Oper

LEGEND	
SYMBOL	DESCRIPTION
⊙	EXISTING SANITARY SEWER MANHOLE
⊕	EXISTING STORM SEWER MANHOLE
⊗	EXISTING WATER MAIN VALVE IN WELL
+	WATER MAIN GATE VALVE IN BOX
⊕	FIRE HYDRANT
⊙	MICHCON GAS CO. VALVE BOX/WELL
⊕	AMERITECH TELEPHONE VAULT
⊙	ELECTRIC MANHOLE
⊕	SOIL BORING
□	EXISTING STORM SEWER INLET
⊕	MONUMENT BOX
▬	REMOVE AND REPLACE CONC. SIDEWALK
▬	PLACE CONCRETE SIDEWALK
▬	REMOVE & REPLACE CONC. CURB & GUTTER
▬	CONSTRUCTION LIMITS
▬	6" WRAPPED UNDERDRAIN
▬	REMOVE CONCRETE SIDEWALK
▬	SUBGRADE UNDERCUT

QUANTITIES				
Sign, Type B, Temp, Prismatic				
Quantity	Sign Code	Description	Area (sft)	Total
15.0	D3-1	Street Name Sign	4.000	60.000
1.0	M4-10	Detour Arrow Sign	6.000	6.000
1.0	M4-8a	End Detour Sign	3.000	3.000
5.0	M4-9L	Detour Sign (w/Left Arrow)	5.000	25.000
0.0	M4-9R	Detour Sign (w/Right Arrow)	5.000	0.000
4.0	M4-9S	Detour Sign (w/Thru Arrow)	5.000	20.000
0.0	R11-2	Road Closed Sign ("Road Closed")	10.000	0.000
0.0	R11-4	Road Closed Sign ("Road Closed To Thru Traffic")	12.500	0.000
1.0	R3-8	Mandatory Movement Lane Control Sign (Left or Right Only)	7.500	7.500
4.0	R6-1 L	One Way (Left) Sign	3.000	12.000
4.0	R6-1R	One Way (Right) Sign	3.000	12.000
3.0	SP-1	Special Sign	20.000	60.000
7.0	W20-1	Road Work Ahead Sign	9.000	63.000
3.0	W20-2	Detour Ahead Sign	9.000	27.000
2.0	W20-3	Road Closed Ahead Sign	9.000	18.000
		TOTAL	313.500	

CONSTRUCTION METHOD AND SEQUENCING

WORK ON THIS STREET INCLUDES, BUT IS NOT LIMITED TO, THE FOLLOWING ITEMS. COMPLETE THE WORK IN ACCORDANCE WITH THE PLANS AND SPECIFICATIONS, AS DIRECTED BY THE ENGINEER, AND UTILIZING PART WIDTH TWO (2) PHASE CONSTRUCTION. PERFORM THE WORK IN THE ORDER INDICATED BELOW UNLESS OTHERWISE AUTHORIZED OR DIRECTED BY THE ENGINEER. COMPLETE ITEMS 6 THRU 12 UTILIZING THE M.O.T. PLAN CURRENTLY IN PLACE, LANE CLOSURES, AND FLAG CONTROL OPERATIONS AS DIRECTED BY THE ENGINEER.

PHASE I

- IMPLEMENT MAINTENANCE OF TRAFFIC (M.O.T.) PLAN, AND INSTALL SOIL EROSION AND SEDIMENTATION CONTROL MEASURES.
- CONDUCT REMOVAL WORK RELATED TO PAVEMENT, DRAINAGE, AND CONCRETE ITEMS WITH EXCEPTION TO COLDMILLING.
- INSTALL PROPOSED DRAINAGE STRUCTURES, STORM SEWER, AND UNDERDRAIN AS REQUIRED.
- PERFORM ALL CONCRETE WORK, INCLUDING RESTORATION.

PHASE II

- REPEAT ITEMS 1 THRU 4 IN THE ORDER SHOWN SHOWN ABOVE.
- REMOVE 1.5 INCHES OF EXISTING HMA SURFACE BY COLDMILLING. THIS MAY INCLUDE GRANULAR BASE MATERIAL. DEPTH TO BE DETERMINED BY THE ENGINEER. PROOF ROLL WITH FULLY LOADED TRUCK.
- PERFORM ALL JOINT AND CRACK CLEANOUT. HMA/HAND PATCHING, UNDERCUTS AND/OR BASE REPAIRS AS REQUIRED.
- GRADE, SHAPE, AND COMPACT THE EXISTING BASE MATERIAL AS REQUIRED.
- CLEAN PAVEMENT AND PLACE 1.5 INCH TOP COURSE HMA MIX (MAJOR STREETS) OVER ENTIRE STREET.
- CLEAN PAVEMENT AND PLACE HMA APPROACHES AS REQUIRED.
- CLEAN PAVEMENT AND COMPLETE ALL PAVEMENT MARKINGS.
- COMPLETE ALL MISCELLANEOUS CONSTRUCTION INCLUDING ALL CLEAN UP AND FINAL RESTORATION.
- REMOVE ALL TRAFFIC CONTROL DEVICES, AND MISS DIG FLAGS.

NOTES

FOR PROTECTION OF UNDERGROUND UTILITIES AND IN CONFORMANCE WITH PUBLIC ACT 174 OF 2013, THE CONTRACTOR SHALL CALL 811 OR 1-800-482-7171 A MINIMUM OF THREE FULL WORKING DAYS, EXCLUDING SATURDAYS, SUNDAYS, AND HOLIDAYS, PRIOR TO BEGINNING EACH EXCAVATION IN AREAS WHERE PUBLIC UTILITIES HAVE NOT BEEN PREVIOUSLY LOCATED. MEMBERS WILL THUS BE ROUTINELY NOTIFIED. THIS DOES NOT RELIEVE THE CONTRACTOR OF THE RESPONSIBILITY OF NOTIFYING UTILITY OWNERS WHO MAY NOT BE A PART OF THE "MISS DIG" ALERT SYSTEM.

THE UNDERGROUND LOCATIONS SHOWN FOR NATURAL GAS, TELEPHONE, ELECTRICAL POWER, CABLE TV AND FIBER OPTIC LINES ARE APPROXIMATE. THE CITY OF ANN ARBOR ASSUMES NO RESPONSIBILITY FOR THEIR ACCURATE REPRESENTATION IN THIS DRAWING. MISS DIG MUST BE CONTACTED PRIOR TO CONSTRUCTION TO LOCATE THESE UTILITIES.

THE IMPROVEMENTS COVERED BY THESE PLANS SHALL BE PERFORMED IN ACCORDANCE WITH MICHIGAN DEPARTMENT OF TRANSPORTATION (MDOT) 2012 STANDARD SPECIFICATIONS FOR CONSTRUCTION, INCLUDING REFERENCED MDOT PUBLICATIONS, AND THE PROJECT CONTRACT DOCUMENTS.



PROJECT MANAGEMENT SERVICES UNIT
CITY OF ANN ARBOR PUBLIC SERVICES
301 EAST HURON STREET, P.O. BOX 8647
ANN ARBOR, MICHIGAN 48107-8647
734-794-6410 www.a2gov.org

PROJECT MANAGEMENT - PUBLIC SERVICES - CITY OF ANN ARBOR

STREET RESURFACING - 2016

DHU VARREN ROAD

DRAWING No. 2016004-25

SHEET No. 25 OF 98

S:\Project Management\Drafting\autocad\2016004\Plan Production\2016004-DHU VARREN RD.dwg Dwg Created: 24-Nov-15 - _a2 standard bw.stb - Plot Date: 15-Mar-16

TRAFFIC CONTROL SIGN		
TAG	SIGN	NUM.
①		D3-1 M4-9S 30x24
②		D3-1 M4-9R 30x24
③		D3-1 M4-9L 30x24
⑥		D3-1 M4-8a 24x18
⑧		SPECIAL 48x60

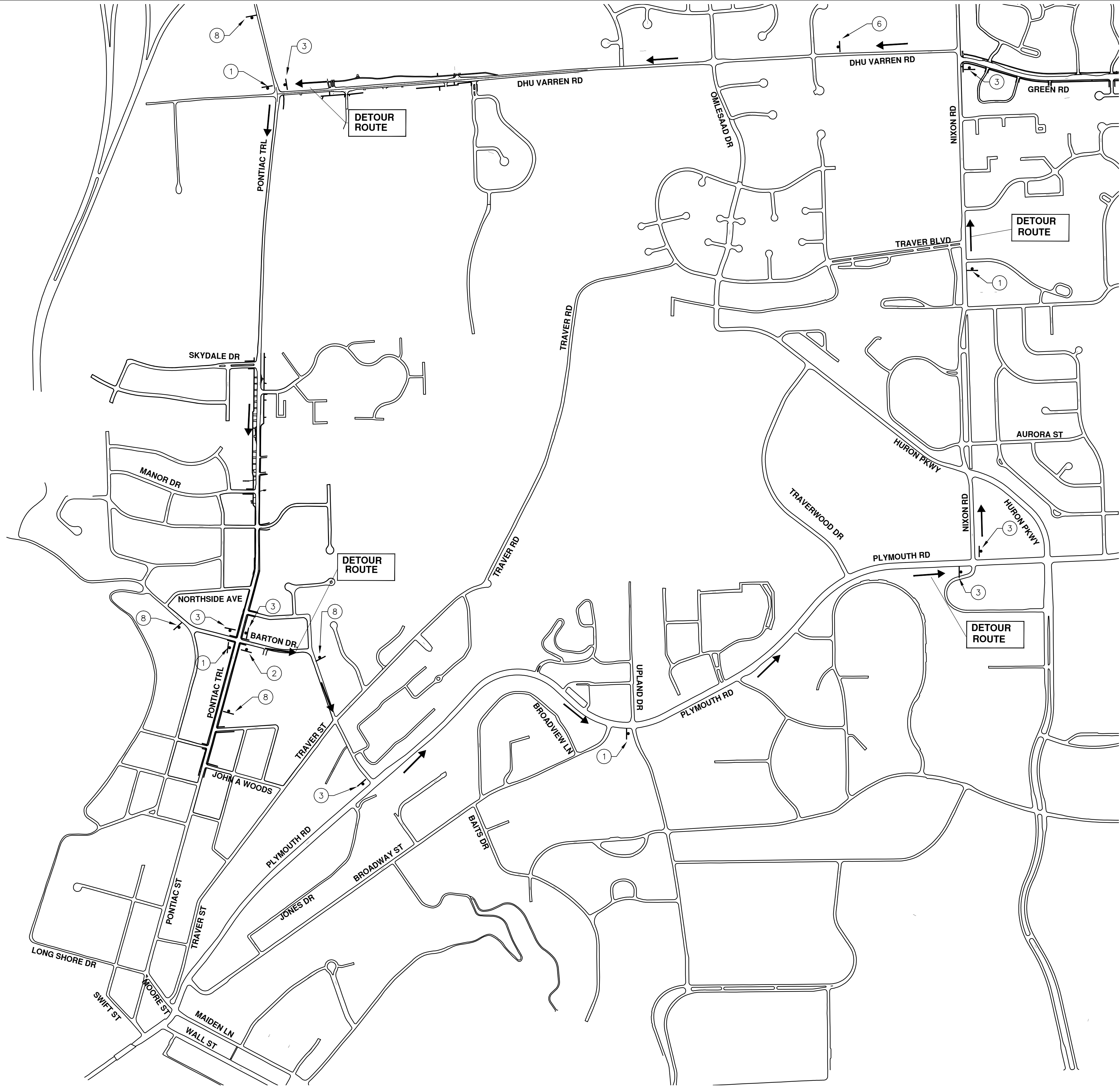

REV.	DATE	DESCRIPTION
02	3-15-2016	ADDENDUM #3
01	3-7-2016	ADDENDUM #1
00	2-22-2016	BID SET

CITY OF ANN ARBOR
PUBLIC SERVICES
301 EAST HURON STREET
ANN ARBOR MI 48106-8647
www.a2gov.org

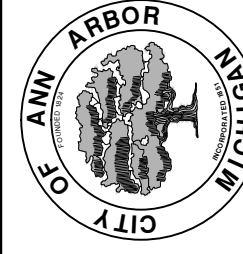

PROJECT MANAGEMENT - PUBLIC SERVICES - CITY OF ANN ARBOR
STREET RESURFACING - 2016
DHU VARREN ROAD
DETOUR

SCALE: N.T.S.
DRAWING No. 2016004-26

S:\Project Management\Drafting\autocad\2016004\Plan Production\2016004-DHU VARREN RD.dwg Dwg Created: 24-Nov-15 - _a2 standard bw.stb - Plot Date: 15-Mar-16

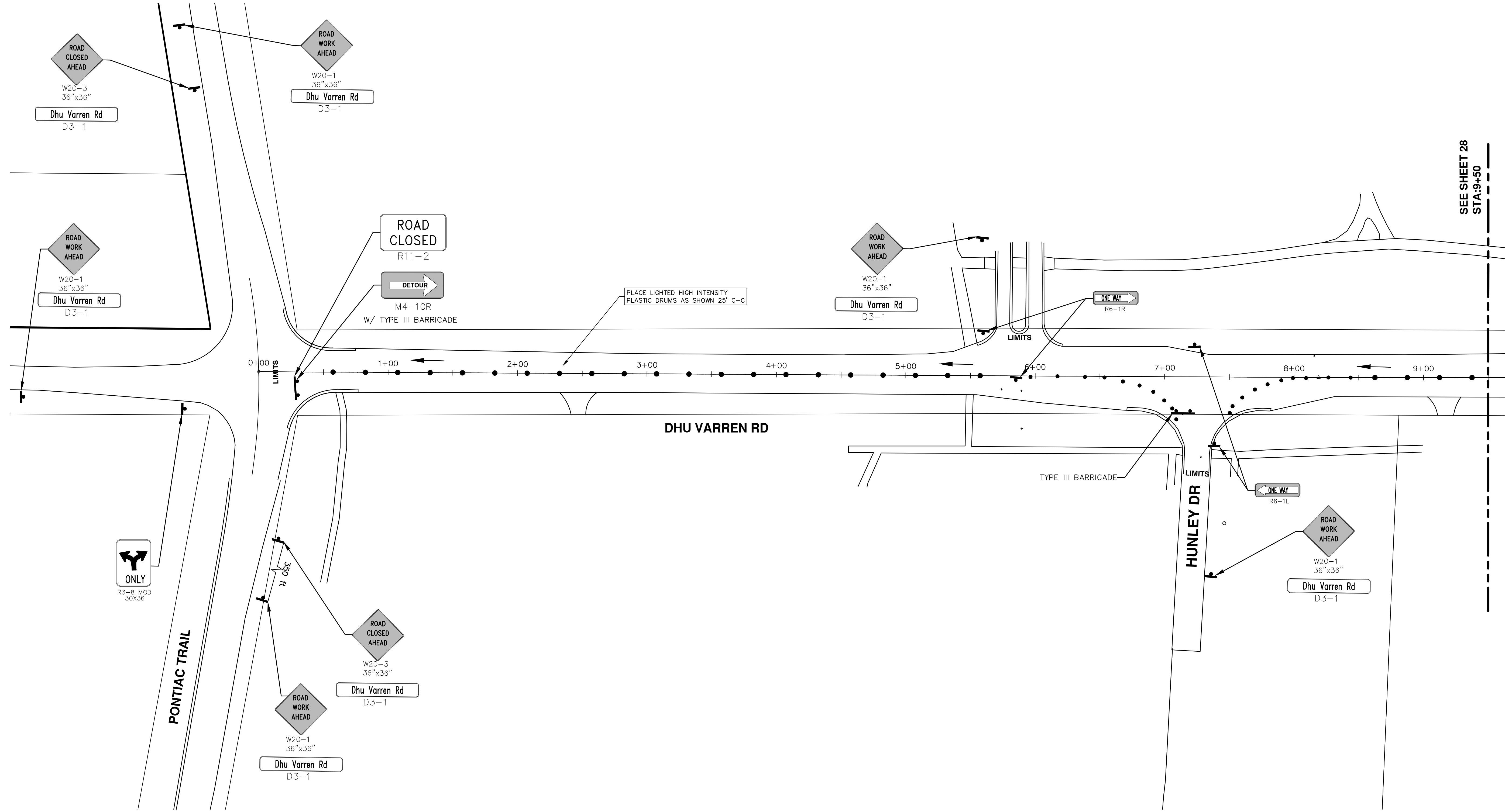

SEE SHEET 28
STA: 9+50



REV.	DATE	DESCRIPTION
02	3-15-2016	DAD
01	3-7-2016	DAD
00	2-22-2016	ISS AH UK
		DAD
		DAD
		DAD
		CHECKED

CITY OF ANN ARBOR
PUBLIC SERVICES
301 EAST HURON STREET
PO BOX 8667
ANN ARBOR MI 4810
www.a2gov.org



PROJECT MANAGEMENT - PUBLIC SERVICES - CITY OF ANN ARBOR
STREET RESURFACING - 2016
DHU VARREN ROAD
TRAFFIC CONTROL

SCALE PLAN: 1" = 40'
DRAWING No. 2016004-27

S:\Project Management\Drafting\autocad\2016004\Plan Production\2016004-DHU VARREN RD.dwg Dwg Created: 24-Nov-15 - _a2 standard bw.stb - Plot Date: 15-Mar-16

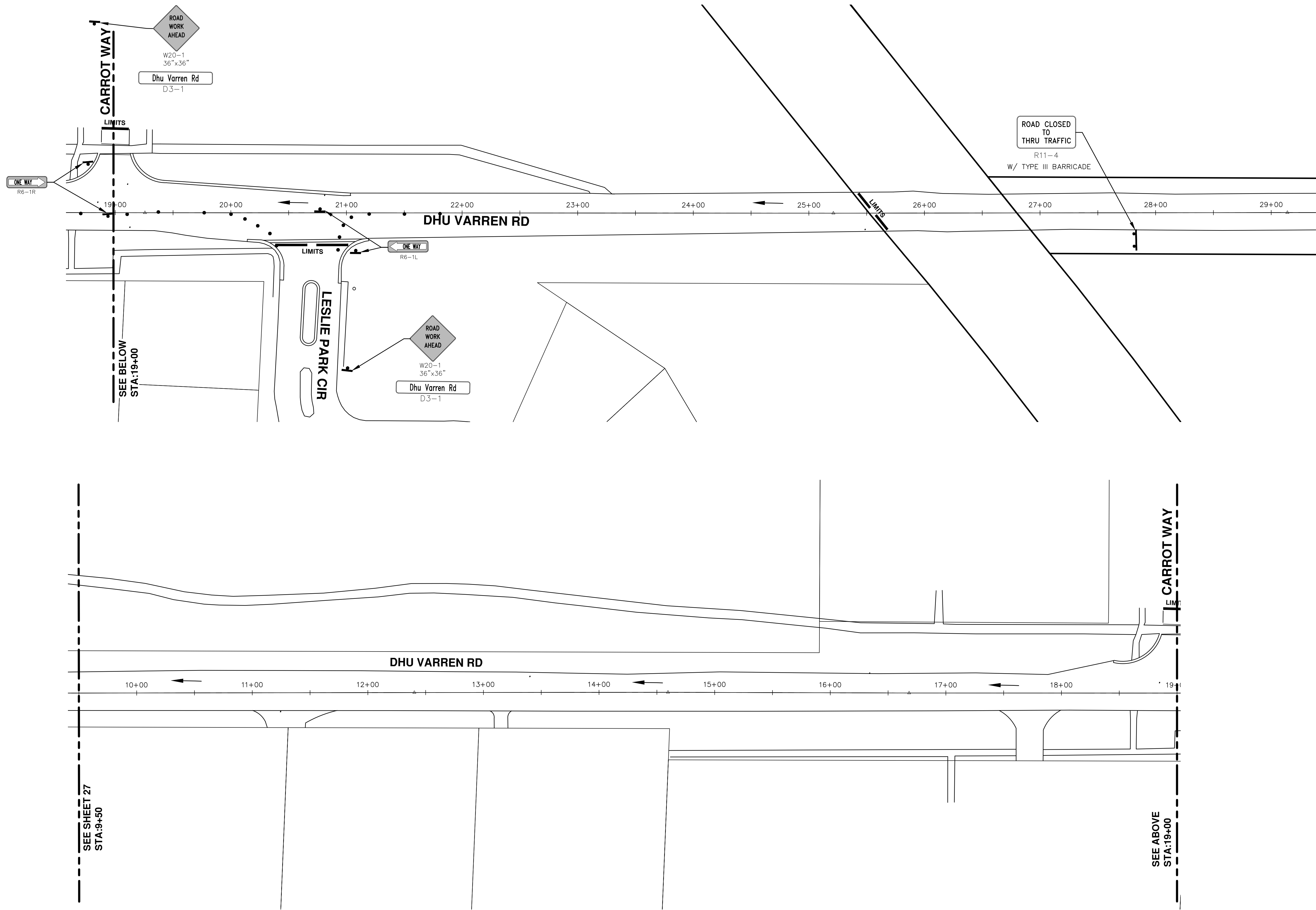

REV.	DESCRIPTION	DATE	DRAWN	CHECKED
02	ADDENDUM #3	3-15-2016	DAD	DAD
01	ADDENDUM #1	3-7-2016	DAD	DAD
00	BID SET	2-22-2016	GS AH JK	DAD

CITY OF ANN ARBOR
PUBLIC SERVICES
301 EAST HURON STREET
ANN ARBOR MI 48106-8647
www.a2gov.org



PROJECT MANAGEMENT - PUBLIC SERVICES - CITY OF ANN ARBOR
STREET RESURFACING - 2016
DHU VARREN ROAD
TRAFFIC CONTROL

SCALE PLAN: 1" = 40'
DRAWING No. 2016004-28

S:\Project Management\Drafting\autocad\2016004\Plan Production\2016004-DHU VARREN RD.dwg Dwg Created: 24-Nov-15 - _a2 standard bw.stb - Plot Date: 15-Mar-16

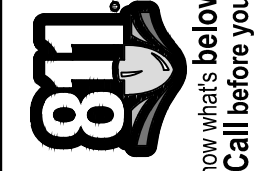
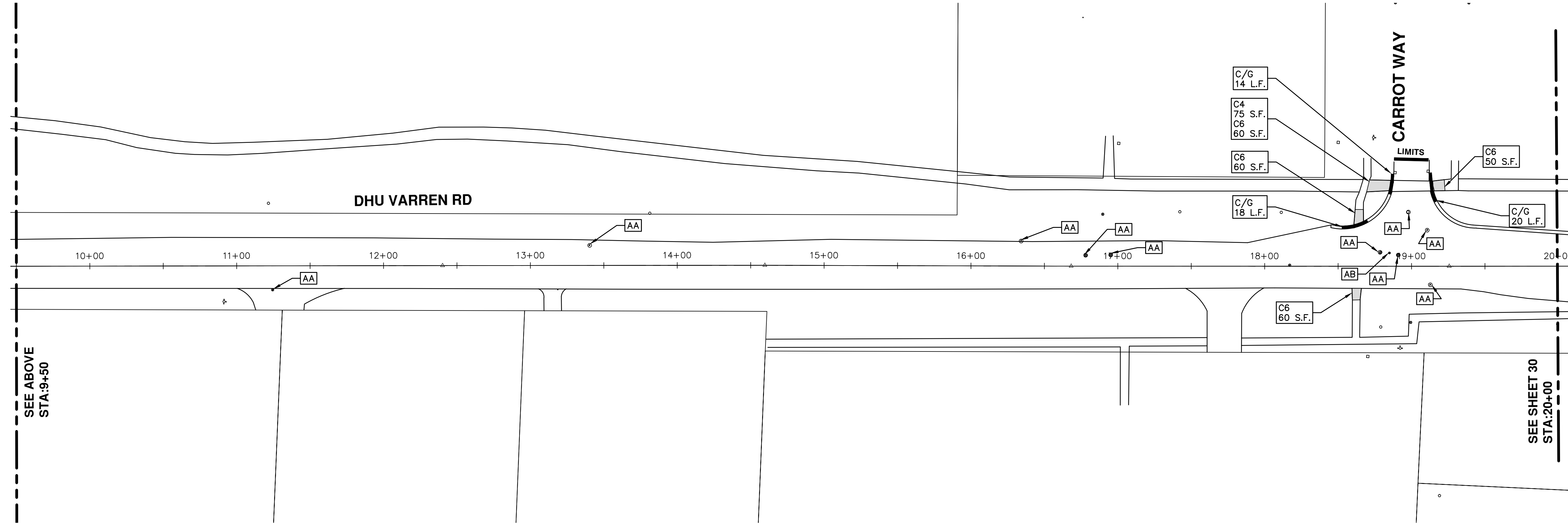
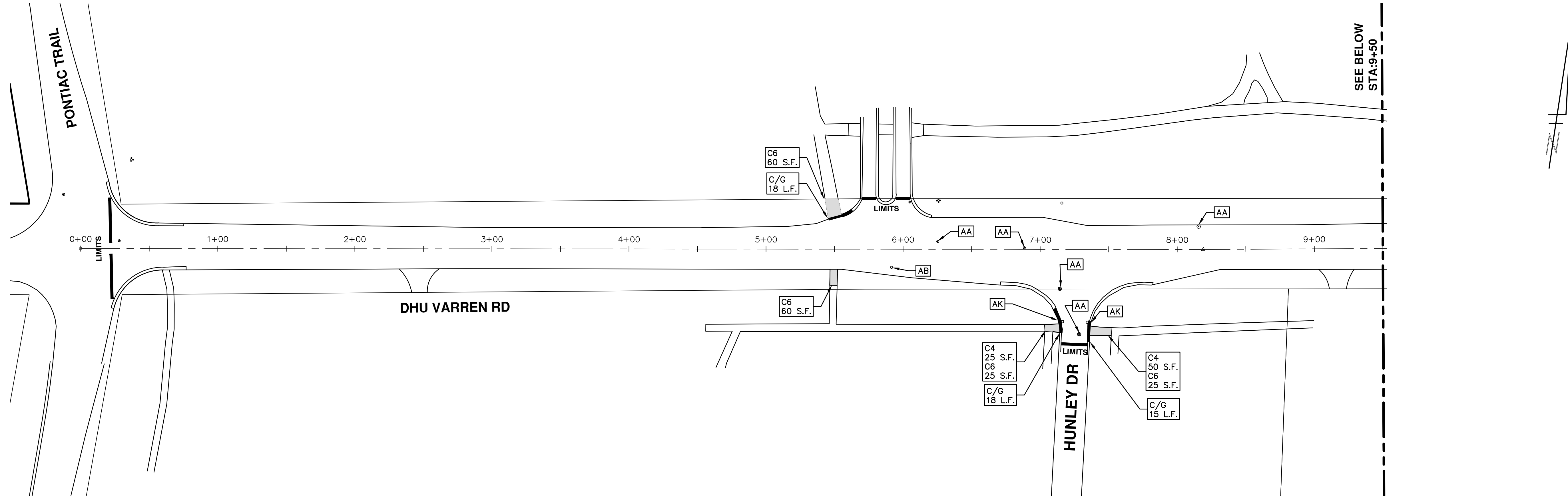

REV.	DESCRIPTION	DATE	DRAWN	CHECKED
02	ADDENDUM #3	3-15-2016	DAD	DAD
01	ADDENDUM #1	3-7-2016	DAD	DAD
00	BID SET	2-22-2016	GS AH JK	DAD

CITY OF ANN ARBOR
PUBLIC SERVICES
301 EAST HURON STREET
ANN ARBOR MI 48106-3647
www.a2gov.org



PROJECT MANAGEMENT - PUBLIC SERVICES - CITY OF ANN ARBOR
STREET RESURFACING - 2016
DHU VARREN ROAD
RESURFACING

SCALE PLAN: 1" = 40'
DRAWING No. 2016004-29

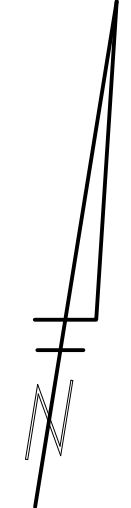
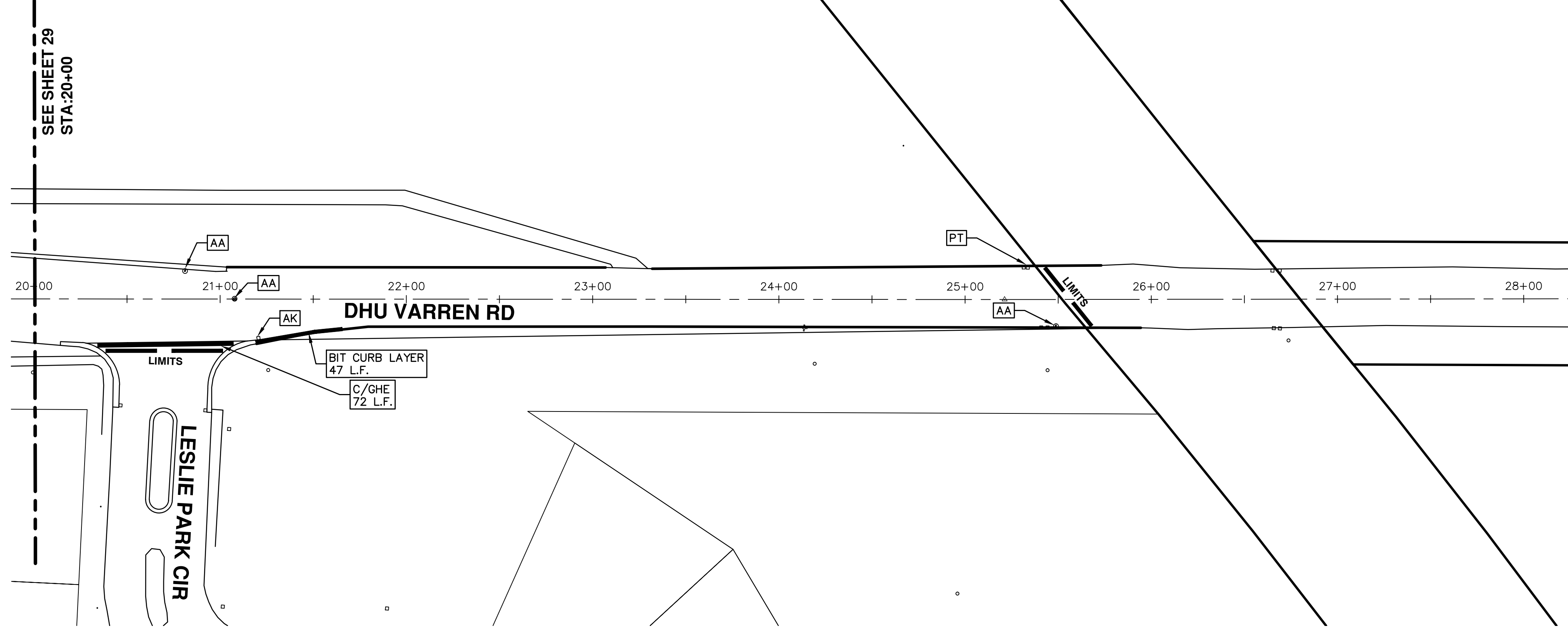

REV.	DESCRIPTION	DATE	DRAWN	CHECKED
02	ADDENDUM #3	3-15-2016	DAD	DAD
01	ADDENDUM #1	3-7-2016	DAD	DAD
00	BID SET	2-22-2016	GS AH JK	DAD

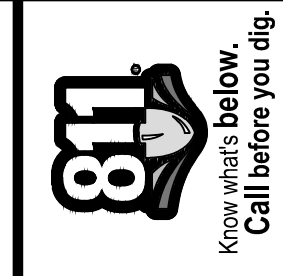

S:\Project Management\Drafting\autocad\2016004\Plan Production\2016004-DHU VARREN RD.dwg Dwg Created: 24-Nov-15 - _a2 standard bw.stb - Plot Date: 15-Mar-16

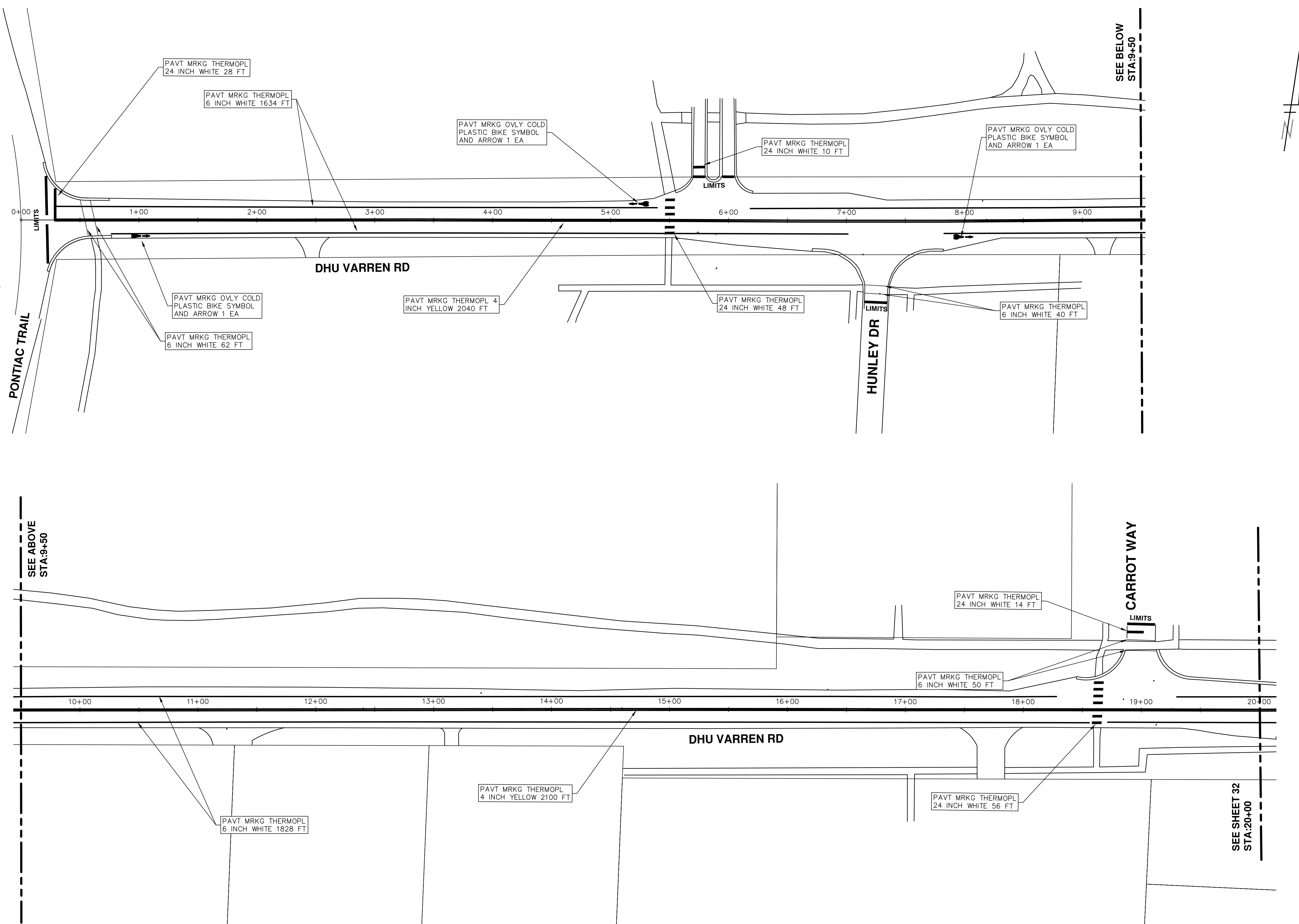

PROJECT MANAGEMENT - PUBLIC SERVICES - CITY OF ANN ARBOR
STREET RESURFACING - 2016
 DHU VARREN ROAD
 PAVEMENT MARKINGS

SCALE PLAN: 1" = 40'

DRAWING No. 2016004-31

811
 Know what's below.
 Call Before you dig.

REV.	DESCRIPTION	DATE	DRAWN	CHECKED
02	ADDENDUM #3	3-15-2016	DAD	DAD
01	ADDENDUM #1	3-7-2016	DAD	DAD
00	BID SET	2-22-2016	GS AH JK	DAD

CITY OF ANN ARBOR
 PUBLIC SERVICES
 301 EAST HURON STREET
 P.O. BOX 8647
 ANN ARBOR MI 48107-8647
 www.a2gov.org

CITY OF ANN ARBOR MICHIGAN

S:\Project Management\Drafting\autocad\2016004\Plan Production\2016004-DHU VARREN RD.dwg Dwg Created: 24-Nov-15 - _a2 standard bw.stb - Plot Date: 15-Mar-16

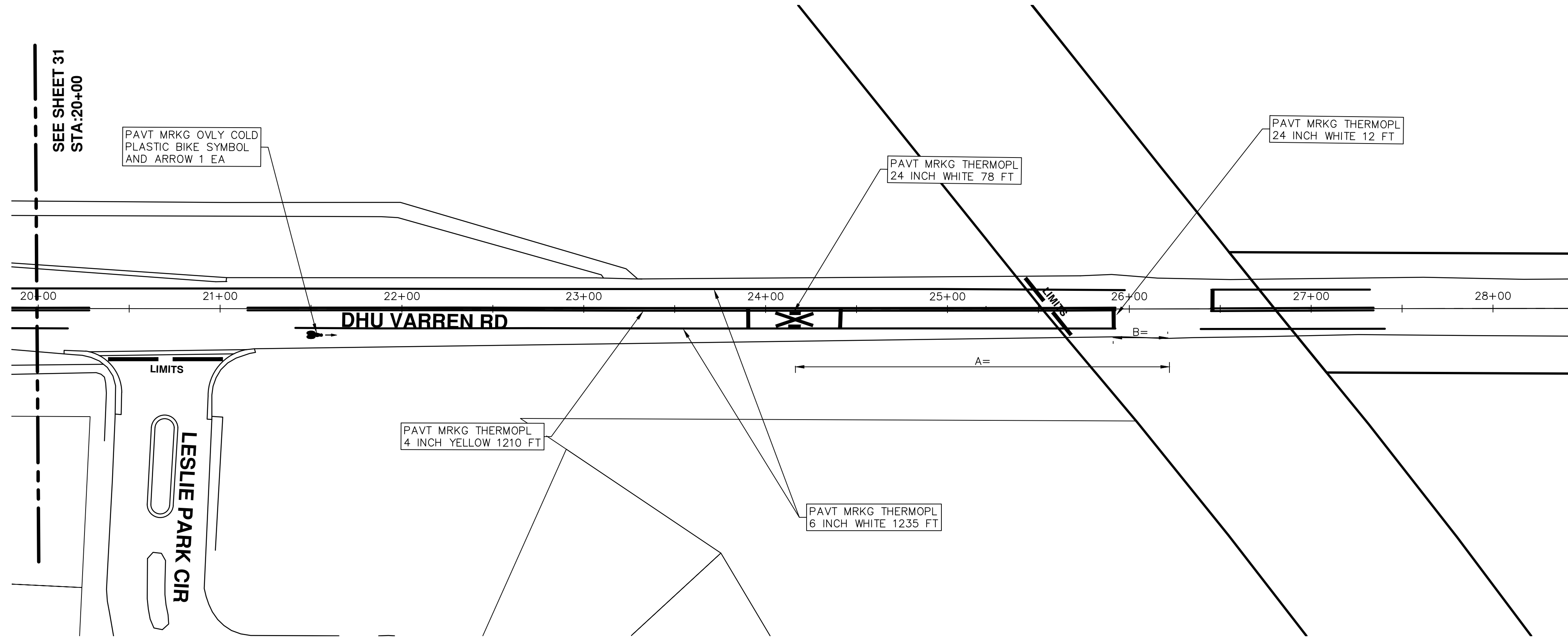

DESIGN SPEED

NOTES:

A= 125' @ 40MPH 175' @ 45MPH FOR R.R. SYMBOL/LEGEND
 B= 15' TYPICAL FOR STOP BAR

Measured from closest rail road track.

 <p>Know what's below. Call Before you dig.</p>	
<p>PROJECT MANAGEMENT - PUBLIC SERVICES - CITY OF ANN ARBOR</p> <p>STREET RESURFACING - 2016</p> <p>DHU VARREN ROAD</p> <p>PAVEMENT MARKINGS</p>	<p>SCALE PLAN: 1" = 40'</p> <p>DRAWING No. 2016004-32</p>
<p>CITY OF ANN ARBOR PUBLIC SERVICES 301 EAST HURON STREET ANN ARBOR, MI 48106-3667 www.a2gov.org</p>	<p>ADDENDUM #3 3-15-2016</p> <p>ADDENDUM #1 3-7-2016</p> <p>BID SET 2-22-2016</p>
<p>REV. DESCRIPTION</p>	<p>DATE DRAWN CHECKED</p>
<p>02</p>	<p>DAD</p>
<p>01</p>	<p>DAD</p>
<p>00</p>	<p>ISS AH JK</p>



CITY OF ANN ARBOR PROJECT MANAGEMENT STREET RESURFACING - 2016 LOCATION: GREEN ROAD

ITB No. 4422 FILE No. 2016004

CONSTRUCTION METHOD AND SEQUENCING

WORK ON THIS STREET INCLUDES, BUT IS NOT LIMITED TO, THE FOLLOWING ITEMS. COMPLETE THE WORK IN ACCORDANCE WITH THE PLANS AND SPECIFICATIONS, AS DIRECTED BY THE ENGINEER, AND UTILIZING PART WIDTH TWO (2) PHASE CONSTRUCTION. PERFORM THE WORK IN THE ORDER INDICATED BELOW UNLESS OTHERWISE AUTHORIZED OR DIRECTED BY THE ENGINEER. COMPLETE ITEMS 7 THRU 15 UTILIZING THE M.O.T. PLAN CURRENTLY IN PLACE, LANE CLOSURES, AND FLAG CONTROL OPERATIONS AS DIRECTED BY THE ENGINEER.

PHASE I

1. IMPLEMENT MAINTENANCE OF TRAFFIC (M.O.T.) PLAN, AND INSTALL SOIL EROSION AND SEDIMENTATION CONTROL MEASURES.
2. CONDUCT REMOVAL WORK RELATED TO PAVEMENT, DRAINAGE, AND CONCRETE ITEMS WITH EXCEPTION TO COLDMILLING.
3. INSTALL PROPOSED DRAINAGE STRUCTURES, STORM SEWER, AND UNDERDRAIN AS REQUIRED.
4. PERFORM ALL CONCRETE WORK, INCLUDING RESTORATION.
5. TEMPORARY LOWER ALL STRUCTURE COVERS LOCATED WITHIN THE EXISTING PAVEMENT AREA, INCLUDING GATE AND MONUMENT BOXES.

PHASE II

6. REPEAT ITEMS 1 THRU 5 IN THE ORDER SHOWN ABOVE.
7. REMOVE 3.5 INCHES OF EXISTING HMA SURFACE BY COLDMILLING. THIS MAY INCLUDE GRANULAR BASE MATERIAL. DEPTH TO BE DETERMINED BY THE ENGINEER. PROOF ROLL WITH FULLY LOADED TRUCK.
8. PERFORM ALL JOINT AND CRACK CLEANOUT. HMA/HAND PATCHING, UNDERCUTS AND/OR BASE REPAIRS AS REQUIRED.
9. GRADE, SHAPE, AND COMPACT THE EXISTING BASE MATERIAL AS REQUIRED.
10. ADJUST ALL STRUCTURE COVERS, INCLUDING GATE AND MONUMENT BOXES, TO THEIR FINISH ELEVATION.
11. CLEAN PAVEMENT AND PLACE 2.0 INCH LEVELING COURSE HMA MIX (MAJOR STREETS).
12. CLEAN PAVEMENT AND PLACE 1.5 INCH TOP COURSE HMA MIX (MAJOR STREETS).
13. CLEAN PAVEMENT AND PLACE HMA APPROACHES AS REQUIRED.
14. CLEAN PAVEMENT AND COMPLETE ALL PAVEMENT MARKINGS.
15. COMPLETE ALL MISCELLANEOUS CONSTRUCTION INCLUDING ALL CLEAN UP AND FINAL RESTORATION.
16. REMOVE ALL TRAFFIC CONTROL DEVICES, AND MISS DIG FLAGS.

NOTES:

FOR PROTECTION OF UNDERGROUND UTILITIES AND IN CONFORMANCE WITH PUBLIC ACT 174 OF 2013, THE CONTRACTOR SHALL CALL 811 OR 1-800-482-7171 A MINIMUM OF THREE FULL WORKING DAYS, EXCLUDING SATURDAYS, SUNDAYS, AND HOLIDAYS, PRIOR TO BEGINNING EACH EXCAVATION IN AREAS WHERE PUBLIC UTILITIES HAVE NOT BEEN PREVIOUSLY LOCATED. MEMBERS WILL THUS BE ROUTINELY NOTIFIED. THIS DOES NOT RELIEVE THE CONTRACTOR OF THE RESPONSIBILITY OF NOTIFYING UTILITY OWNERS WHO MAY NOT BE A PART OF THE "MISS DIG" ALERT SYSTEM.

THE UNDERGROUND LOCATIONS SHOWN FOR NATURAL GAS, TELEPHONE, ELECTRICAL POWER, CABLE TV AND FIBER OPTIC LINES ARE APPROXIMATE. THE CITY OF ANN ARBOR ASSUMES NO RESPONSIBILITY FOR THEIR ACCURATE REPRESENTATION IN THIS DRAWING. MISS DIG MUST BE CONTACTED PRIOR TO CONSTRUCTION TO LOCATE THESE UTILITIES.

THE IMPROVEMENTS COVERED BY THESE PLANS SHALL BE PERFORMED IN ACCORDANCE WITH MICHIGAN DEPARTMENT OF TRANSPORTATION (MDOT) 2012 STANDARD SPECIFICATIONS FOR CONSTRUCTION, INCLUDING REFERENCED MDOT PUBLICATIONS, AND THE PROJECT CONTRACT DOCUMENTS.

QUANTITIES			
Item Code	Item Description	Units	Quantity
2030011	Dr Structure, Rem	Ea	2.000
2030015	Sewer, Rem, Less than 24 inch	Ft	20.000
2047001	Curb, Gutter, and Curb and Gutter, Any Type, Rem	Ft	1,247.000
2047011	Sidewalk, Sidewalk Ramp, and Driveway Approach, Any Thickness, Rem	Syd	98.000
2057011	Grading, Sidewalk	Syd	56.000
2057011	Grading, Sidewalk Ramp	Syd	42.000
2057021	Subgrade Undercutting, Type IIA	Cyd	1,689.000
2087050	Erosion Control, Inlet Filter	Ea	23.000
4020987	Sewer, CI IV, 12 inch, Tr Det B	Ft	20.000
4030200	Dr Structure, 24 inch dia	Ea	2.000
4037050	Dr Structure Cover, Type B, Modified	Ea	3.000
4037050	Dr Structure Cover, Type K, Modified	Ea	6.000
4037050	Dr Structure, Adj, Case 1, Modified	Ea	21.000
4037050	Dr Structure, Point	Ea	4.000
4037050	Dr Structure, Temp Lowering, Modified	Ea	17.000
5010003	Cold Milling HMA Surface	Ton	3,692.000
5010005	HMA Surface, Rem	Syd	427.000
5010051	HMA, 4E3	Ton	1,909.000
5010057	HMA, 5E3	Ton	1,431.000
5010061	HMA, Approach	Ton	352.000
6027021	Flowable Fill	Cyd	46.185
8027001	Curb and Gutter, Conc	Ft	1,250.000
8037001	Detectable Warning Surface, Modified	Ft	35.000
8037010	Sidewalk Ramp, Conc, 6 inch, Modified	Sft	375.000
8037010	Sidewalk, Conc, 4 inch, Modified	Sft	500.000
8110049	Pav Mrkg, Ovy Cold Plastic, Direction Arrow Sym, Bike	Ea	8.000
8110058	Pav Mrkg, Ovy Cold Plastic, Bike, Small Sym	Ea	8.000
8110153	Pav Mrkg, Sprayable Thermopl, 4 inch, White	Ft	1,108.000
8110154	Pav Mrkg, Sprayable Thermopl, 4 inch, Yellow	Ft	10,421.000
8110155	Pav Mrkg, Sprayable Thermopl, 6 inch, White	Ft	4,259.000
8110197	Pav Mrkg, Thermopl, 6 inch, Crosswalk	Ft	235.000
8110212	Pav Mrkg, Thermopl, 12 inch, Cross Hatching, White	Ft	225.000
8110218	Pav Mrkg, Thermopl, 24 inch, Stop Bar	Ft	56.000
8117001	Pav Mrkg, Thermopl, 24 inch, Crosswalk	Ft	296.000
8117050	Pav Mrkg, Thermopl, Lt Turn Arrow Sym	Ea	3.000
8117050	Pav Mrkg, Thermopl, Only	Ea	3.000
8117050	Pav Mrkg, Thermopl, Rt Turn Arrow Sym	Ea	2.000
8120012	Barricade, Type III, High Intensity, Double Sided, Lighted, Furn	Ea	12.000
8120013	Barricade, Type III, High Intensity, Double Sided, Lighted, Oper	Ea	12.000
8120140	Lighted Arrow, Type C, Furn	Ea	1.000
8120141	Lighted Arrow, Type C, Oper	Ea	1.000
8120260	Plastic Drum, High Intensity, Lighted, Furn	Ea	160.000
8120261	Plastic Drum, High Intensity, Lighted, Oper	Ea	160.000
8120330	Sign, Portable, Changeable Message, Furn	Ea	2.000
8120331	Sign, Portable, Changeable Message, Oper	Ea	2.000
8120350	Sign, Type B, Temp, Prismatic, Furn	Sft	338.500
8120351	Sign, Type B, Temp, Prismatic, Oper	Sft	338.500
8167011	Slope Restoration	Syd	458.000

CONSTRUCTION KEY	
KEY	ASSOCIATED PAY ITEM(S)
AA	• Dr Structure, Adj, Case 1, Modified • Dr Structure, Adj, Case 2, Modified • Dr Structure, Temp Lowering, Modified
AB	• Dr Structure, Temp Lowering, Modified • Gate Box, Adj, Case 1 • Gate Box, Adj, Case 2 • Monument Box Adjust
ADST	• Dr Structure, Adj, Add Depth, Modified
AK	• Dr Structure, Adj, Case 1, Modified
C4	• Sidewalk, Sidewalk Ramp, and Driveway Approach, Any Thickness, Rem • Grading, Sidewalk • Sidewalk, Conc, 4 inch, Modified
C4HE	• Sidewalk, Sidewalk Ramp, and Driveway Approach, Any Thickness, Rem • Grading, Sidewalk • Cement • Sidewalk, Conc, 4 inch, Modified
C6	• Sidewalk, Sidewalk Ramp, and Driveway Approach, Any Thickness, Rem • Grading, Sidewalk • Sidewalk Ramp • Detectable Warning Surface, Modified • Sidewalk Ramp, Conc, 6 inch, Modified • Sidewalk, Conc, 6 inch, Modified
C8	• Grading, Driveway Approach • Driveway, Nonreinf Conc, 8 inch, Modified
CHE	• Sidewalk, Sidewalk Ramp, and Driveway Approach, Any Thickness, Rem • Grading, Driveway Approach • Grading, Sidewalk • Grading, Sidewalk Ramp • Cement • Driveway, Nonreinf Conc, 6 inch, Modified • Driveway, Nonreinf Conc, 8 inch, Modified • Detectable Warning Surface, Modified • Sidewalk Ramp, Conc, 6 inch, Modified • Sidewalk, Conc, 6 inch, Modified
C/G	• Curb, Gutter, and Curb and Gutter, Any Type, Rem • Curb and Gutter, Conc
C/GHE	• Curb, Gutter, and Curb and Gutter, Any Type, Rem • Cement • Driveway Opening, Conc, Det M, Modified
CP	• Grading, Sidewalk • Sidewalk, Conc, 4 inch, Modified
CR	• Sidewalk, Sidewalk Ramp, and Driveway Approach, Any Thickness, Rem • Dr Structure, Rem
DS	• Sewer, Rem, Less than 24 inch • Dr Structure, 24 inch dia
DSDI	• Dr Structure, Rem • Sewer, Rem, Less than 24 inch • Dr Structure, Double Inlet
PT	• Dr Structure, Point
RRA	• Dr Structure Cover, Type B • Dr Structure Cover, Type B, Special • Dr Structure, Adj, Case 1, Modified • Dr Structure, Temp Lowering, Modified
RRK	• Dr Structure Cover, Type K • Dr Structure, Adj, Case 1, Modified
RS	• Dr Structure, Reconstruct
TYPE I	• Plastic Drum, High Intensity, Lighted, Furn • Plastic Drum, High Intensity, Lighted, Oper
TYPE II	• Barricade, Type III, High Intensity, Double Sided, Lighted, Furn • Barricade, Type III, High Intensity, Double Sided, Lighted, Oper

LEGEND	
SYMBOL	DESCRIPTION
⊙	EXISTING SANITARY SEWER MANHOLE
⊕	EXISTING STORM SEWER MANHOLE
⊗	EXISTING WATER MAIN VALVE IN WELL
+	WATER MAIN GATE VALVE IN BOX
⊕	FIRE HYDRANT
⊙	MICHCON GAS CO. VALVE BOX/WELL
⊕	AMERITECH TELEPHONE VAULT
⊙	ELECTRIC MANHOLE
⊕	SOIL BORING
□	EXISTING STORM SEWER INLET
■	MONUMENT BOX
▬	REMOVE AND REPLACE CONC. SIDEWALK
▬	PLACE CONCRETE SIDEWALK
▬	REMOVE & REPLACE CONC. CURB & GUTTER
---	CONSTRUCTION LIMITS
---	6" WRAPPED UNDERDRAIN
▨	REMOVE CONCRETE SIDEWALK
▬	SUBGRADE UNDERCUT

QUANTITIES				
Sign, Type B, Temp, Prismatic				
Quantity	Sign Code	Description	Area (sft)	Total
30.0	D3-1	Street Name Sign	4.000	120.000
1.0	M4-10R	Detour Arrow (Right) Sign	6.000	6.000
1.0	M4-8a	End Detour Sign	3.000	3.000
4.0	M4-9L	Detour Sign (w/Left Arrow)	5.000	20.000
2.0	M4-9R	Detour Sign (w/Right Arrow)	5.000	10.000
5.0	M4-9S	Detour Sign (w/Thru Arrow)	5.000	25.000
0.0	R11-2	Road Closed Sign ("Road Closed")	10.000	0.000
0.0	R11-4	Road Closed Sign ("Road Closed To Thru Traffic")	12.500	0.000
1.0	R3-1	Movement Prohibition Sign ("No Right Turn")	4.000	4.000
1.0	R3-2	Movement Prohibition Sign ("No Left Turn")	4.000	4.000
1.0	R3-8	Advance Intersection Lane Control Sign (Left/Right Turn Only)	7.500	7.500
8.0	R6-1L	One Way (Left) Sign	3.000	24.000
8.0	R6-1R	One Way (Right) Sign	3.000	24.000
5.0	SP-1	Special Sign	20.000	100.000
13.0	W20-1	Road Work Ahead Sign	9.000	117.000
2.0	W20-2	Detour Ahead Sign	9.000	18.000
3.0	W20-3	Road Closed Ahead Sign	9.000	27.000
1.0	W20-4	One Lane Road Sign ("One Lane Road Ahead")	9.000	9.000
		TOTAL		398.500

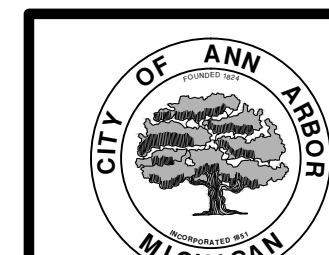

PROJECT MANAGEMENT SERVICES UNIT
CITY OF ANN ARBOR PUBLIC SERVICES
301 EAST HURON STREET, P.O. BOX 8647
ANN ARBOR, MICHIGAN 48107-8647
734-794-6410 www.a2gov.org

S:\Project Management\Drafting\autocad\2016004\Plan Production\2016004-GREEN RD.dwg Dwg Created: 24-Nov-15 - a2 standard bw.stb - Plot Date: 15-Mar-16

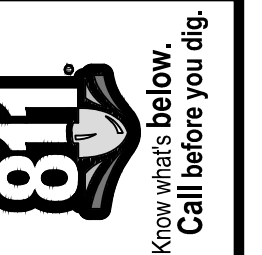

PROJECT MANAGEMENT - PUBLIC SERVICES - CITY OF ANN ARBOR
STREET RESURFACING - 2016
GREEN ROAD
DRAWING No. 2016004-33

TRAFFIC CONTROL SIGN		
TAG	SIGN	NUM.
①		D3-1 M4-9S 30x24
②		D3-1 M4-9R 30x24
③		D3-1 M4-9L 30x24
⑥		D3-1 M4-8a 24x18
⑧		SPECIAL 48x60

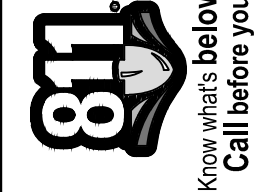
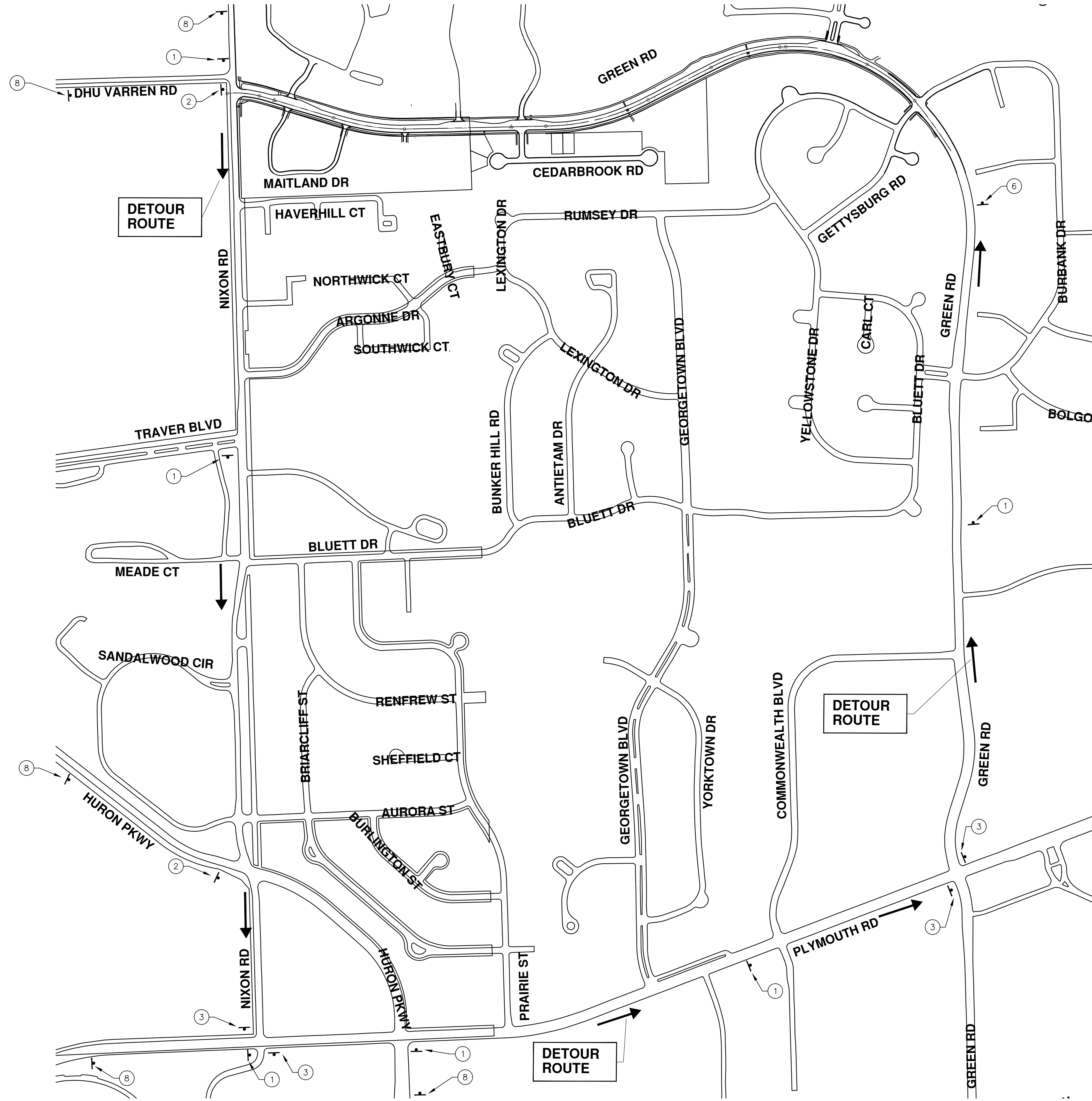

REV.	DESCRIPTION	DATE	DRAWN	CHECKED
02	ADDENDUM #3	3-15-2016	DAD	DAD
01	ADDENDUM #1	3-7-2016	DAD	DAD
00	BID SET	2-22-2016	SS AH JK	DAD

CITY OF ANN ARBOR
PUBLIC SERVICES
301 EAST HURON STREET
ANN ARBOR MI 48106-8647
www.a2gov.org



PROJECT MANAGEMENT - PUBLIC SERVICES - CITY OF ANN ARBOR
STREET RESURFACING - 2016
GREEN ROAD
DETOUR

SCALE PLAN: Custom
DRAWING No. 2016004-34

S:\Project Management\Drafting\autocad\2016004\Plan Production\2016004-GREEN RD.dwg Dwg Created: 24-Nov-15 - _a2 standard bw.stb - Plot Date: 15-Mar-16

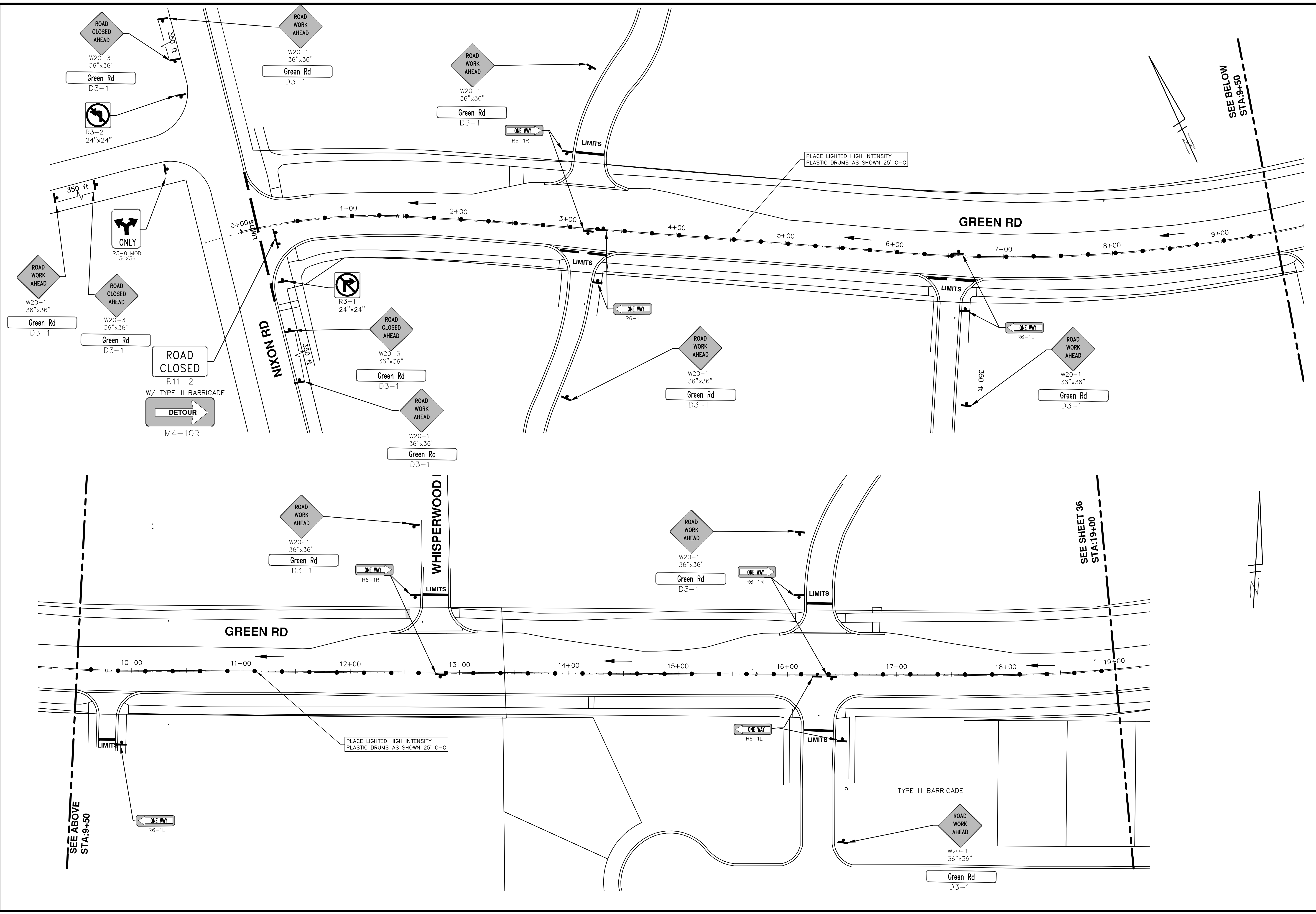

PROJECT MANAGEMENT - PUBLIC SERVICES - CITY OF ANN ARBOR
STREET RESURFACING - 2016
 GREEN ROAD
 TRAFFIC CONTROL

SCALE PLAN: 1" = 40'
 DRAWING No. 2016004-35

811
 Know what's below.
 Call Before you dig.

REV.	DATE	DESCRIPTION	DRAWN	CHECKED
02	3-15-2016	ADDENDUM #3	DAD	DAD
01	3-7-2016	ADDENDUM #1	DAD	DAD
00	2-22-2016	BID SET	GS AH UK	DAD

CITY OF ANN ARBOR
 PUBLIC SERVICES
 301 EAST HURON STREET
 ANN ARBOR, MI 48106-0647
 www.a2gov.org

S:\Project Management\Drafting\autocad\2016004\Plan Production\2016004-GREEN RD.dwg Dwg Created: 24-Nov-15 - _a2 standard bw.stb - Plot Date: 15-Mar-16

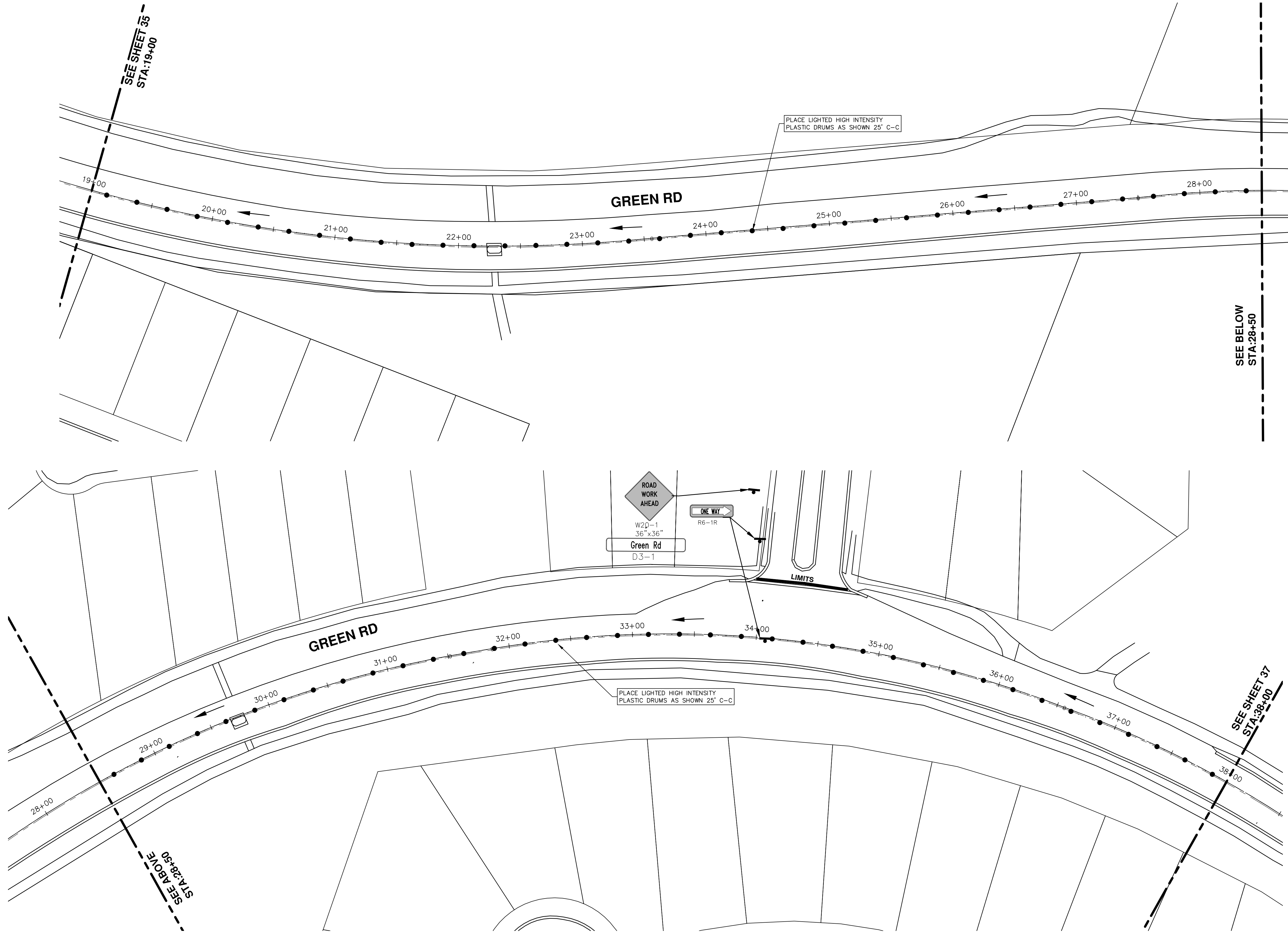

REV.	DESCRIPTION	DATE	DRAWN	CHECKED
02	ADDENDUM #3	3-15-2016	DAD	DAD
01	ADDENDUM #1	3-7-2016	DAD	DAD
00	BID SET	2-22-2016	GS AH JK	DAD

CITY OF ANN ARBOR
 PUBLIC SERVICES
 301 EAST HURON STREET
 P.O. BOX 8647
 ANN ARBOR MI 48108-8647
 www.a2gov.org

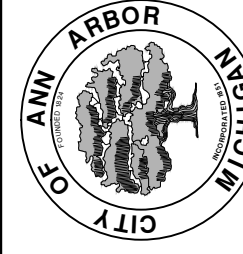

PROJECT MANAGEMENT - PUBLIC SERVICES - CITY OF ANN ARBOR
STREET RESURFACING - 2016
 GREEN ROAD
 TRAFFIC CONTROL

SCALE PLAN: 1" = 40'
 DRAWING No. 2016004-36

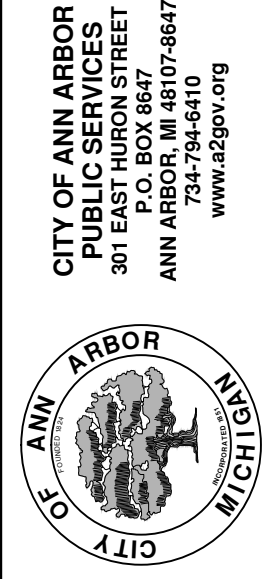
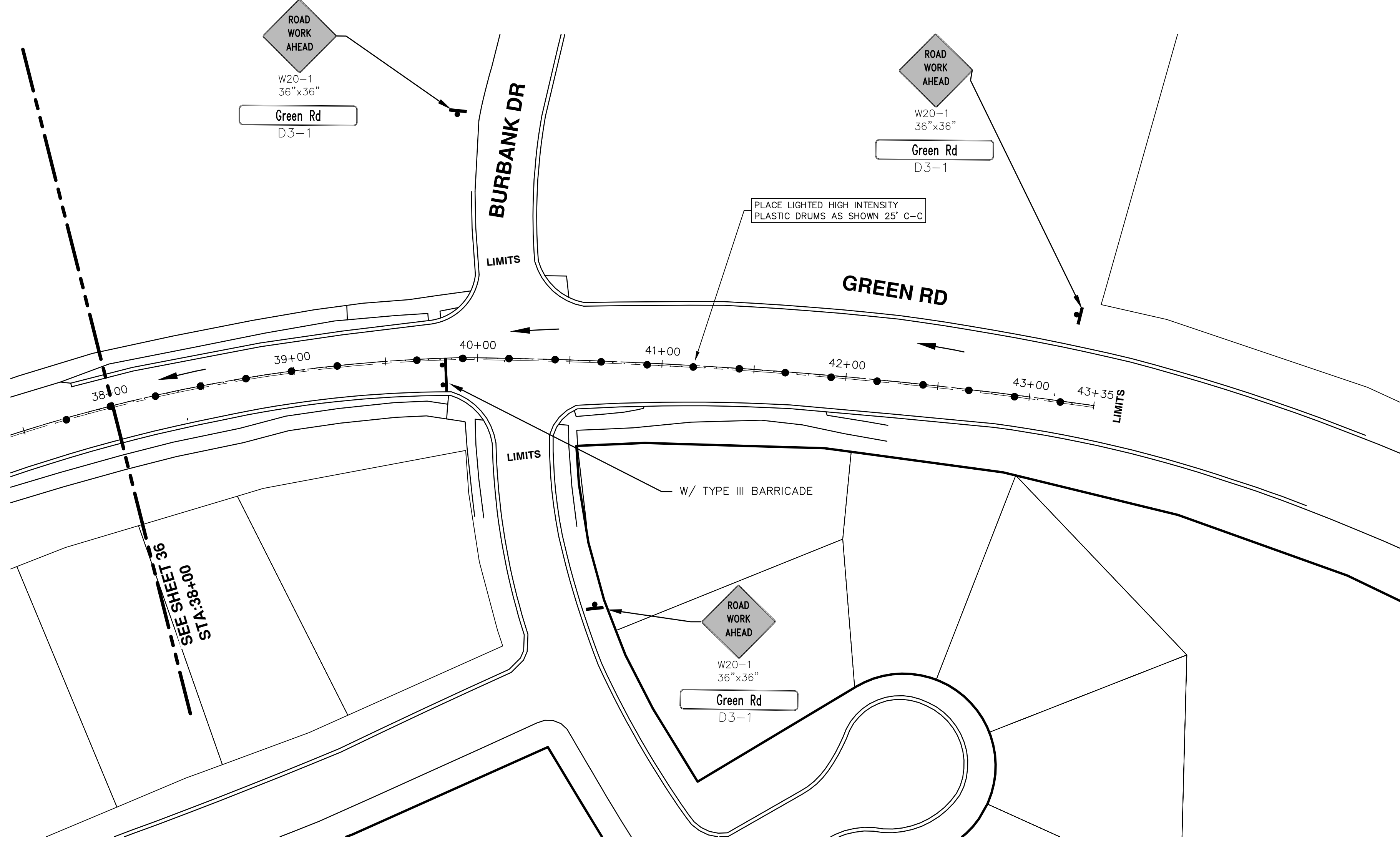

REV.	DESCRIPTION	DATE	DRAWN	CHECKED
02	ADDENDUM #3	3-15-2016	DAD	DAD
01	ADDENDUM #1	3-7-2016	DAD	DAD
00	BID SET	2-22-2016	GSS AH JK	DAD



S:\Project Management\Drafting\autocad\2016004\Plan Production\2016004-GREEN RD.dwg Dwg Created: 24-Nov-15 - _a2 standard bw.stb - Plot Date: 15-Mar-16

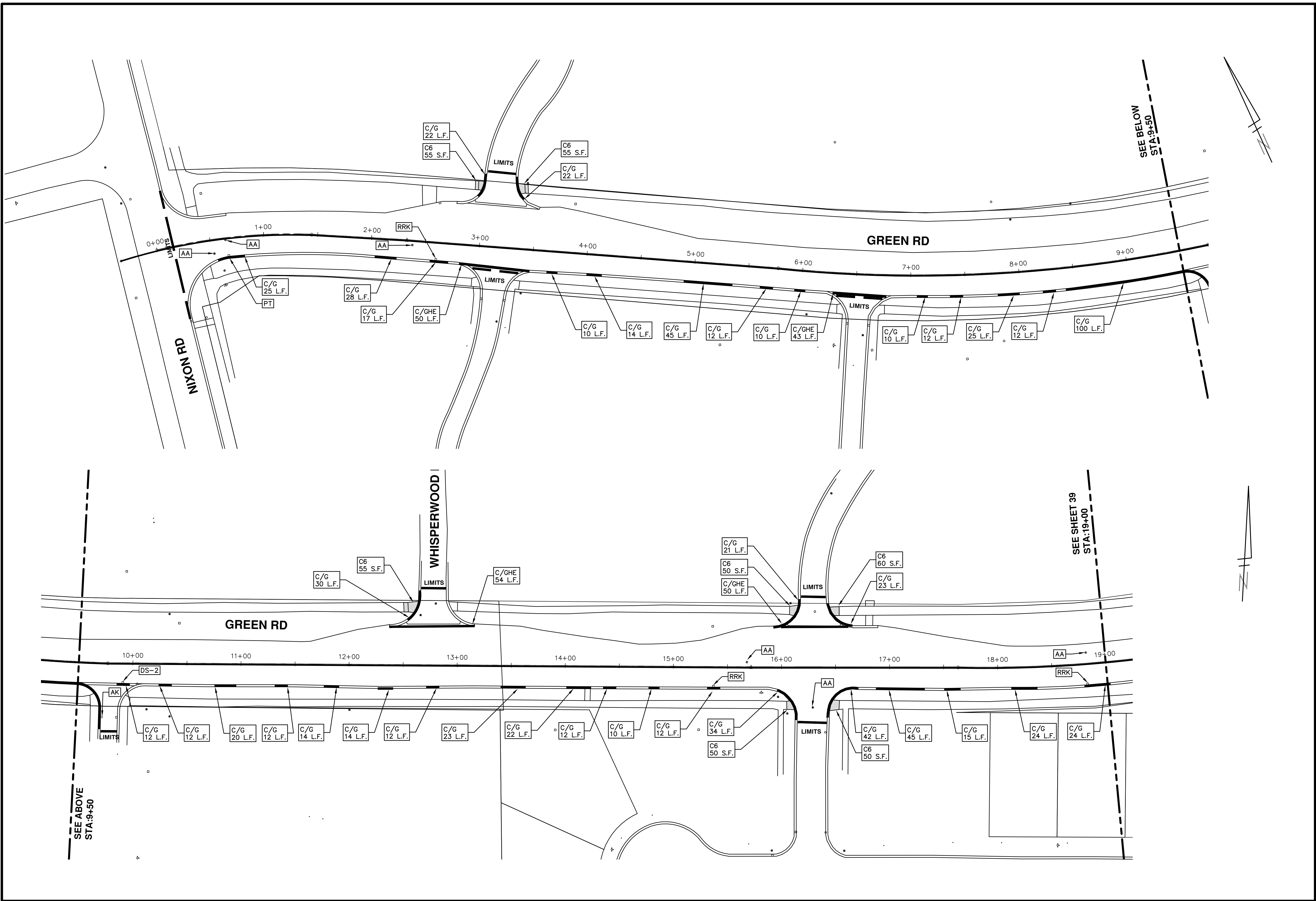

PROJECT MANAGEMENT - PUBLIC SERVICES - CITY OF ANN ARBOR
STREET RESURFACING - 2016
 GREEN ROAD
 RESURFACING

SCALE PLAN: 1" = 40'
 DRAWING No. 2016004-38

811
 Know what's below.
 Call Before you dig.

REV.	DESCRIPTION	DATE	DRAWN	CHECKED
02	ADDENDUM #3	3-15-2016	DAD	DAD
01	ADDENDUM #1	3-7-2016	DAD	DAD
00	BID SET	2-22-2016	GS AH JK	DAD

CITY OF ANN ARBOR
 PUBLIC SERVICES
 301 EAST HURON STREET
 ANN ARBOR, MI 48106-8647
 www.a2gov.org

S:\Project Management\Drafting\autocad\2016004\Plan Production\2016004-GREEN RD.dwg Dwg Created: 24-Nov-15 - _a2 standard bw.stb - Plot Date: 15-Mar-16

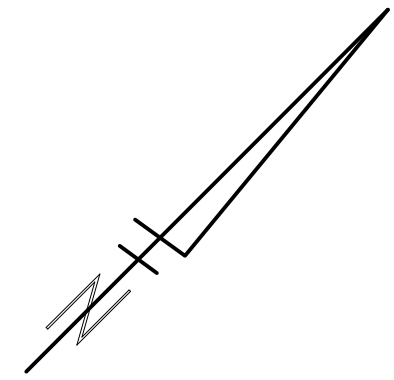
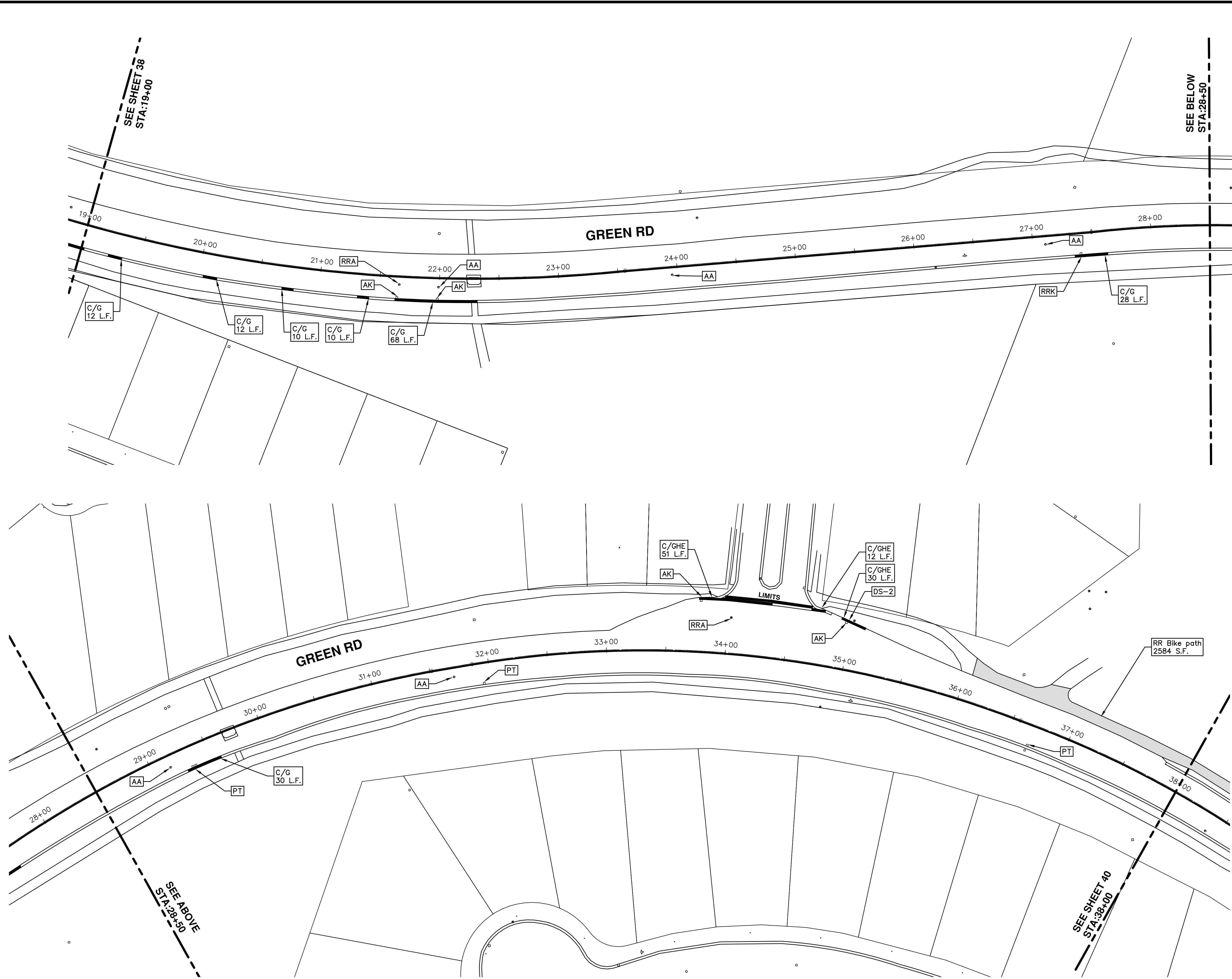

REV.	DESCRIPTION	DATE	DRAWN	CHECKED
02	ADDENDUM #3	3-15-2016	DAD	DAD
01	ADDENDUM #1	3-7-2016	DAD	DAD
00	BID SET	2-22-2016	GS AH JK	DAD

CITY OF ANN ARBOR
PUBLIC SERVICES
301 EAST HURON STREET
ANN ARBOR MI 48106-8647
www.a2gov.org

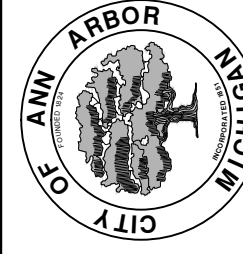

PROJECT MANAGEMENT - PUBLIC SERVICES - CITY OF ANN ARBOR
STREET RESURFACING - 2016
GREEN ROAD
RESURFACING

SCALE PLAN: 1" = 40'
DRAWING No. 2016004-39

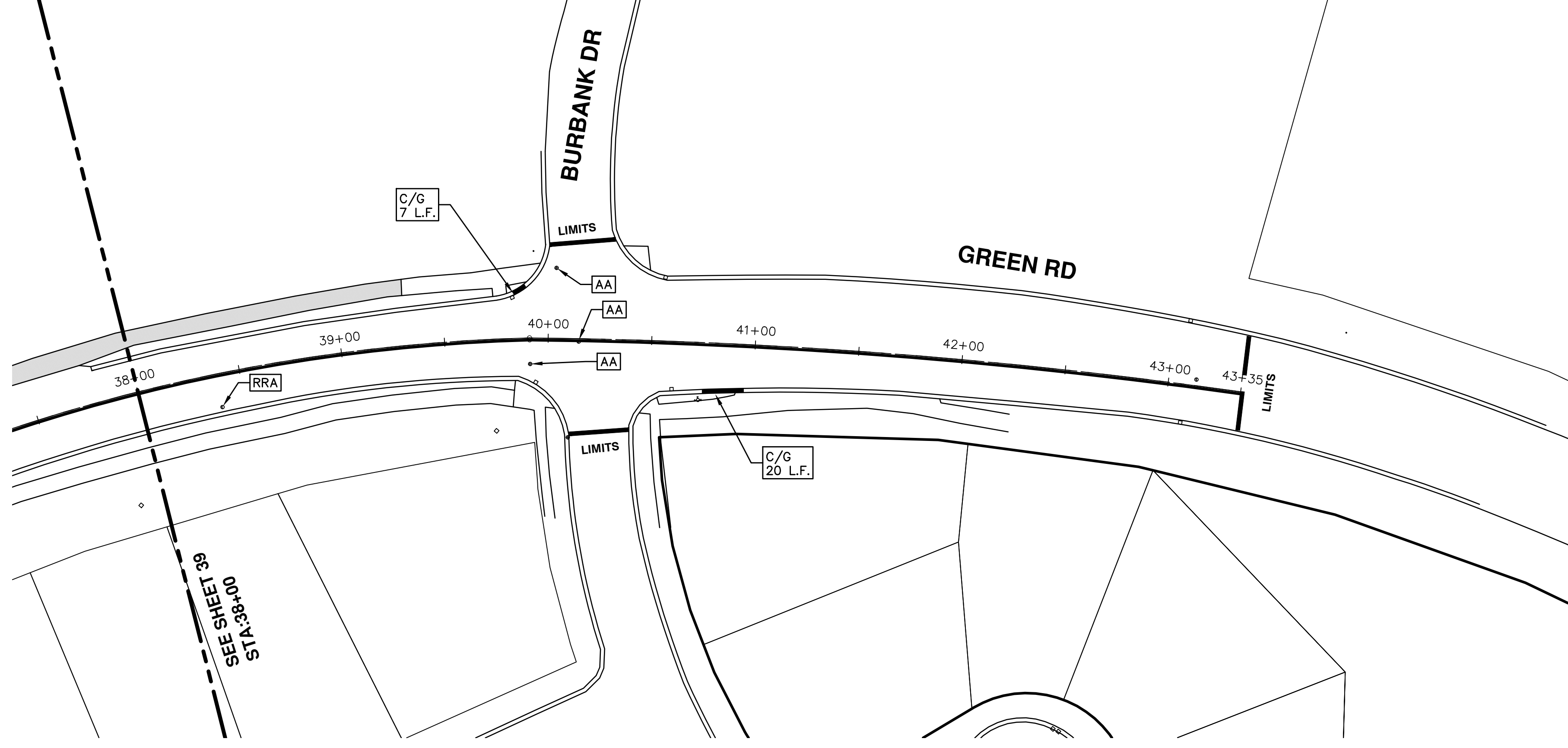

SEE SHEET 39
STA: 38+00.00



CITY OF ANN ARBOR
PUBLIC SERVICES
301 EAST HURON STREET
ANN ARBOR, MI 48106-1667
www.a2gov.org

REV.	DESCRIPTION	DATE	DRAWN	CHECKED
02	ADDENDUM #3	3-15-2016	DAD	DAD
01	ADDENDUM #1	3-7-2016	DAD	DAD
00	BID SET	2-22-2016	ISS AH JK	DAD



S:\Project Management\Drafting\autocad\2016004\Plan Production\2016004-GREEN RD.dwg Dwg Created: 24-Nov-15 - _a2 standard bw.stb - Plot Date: 15-Mar-16

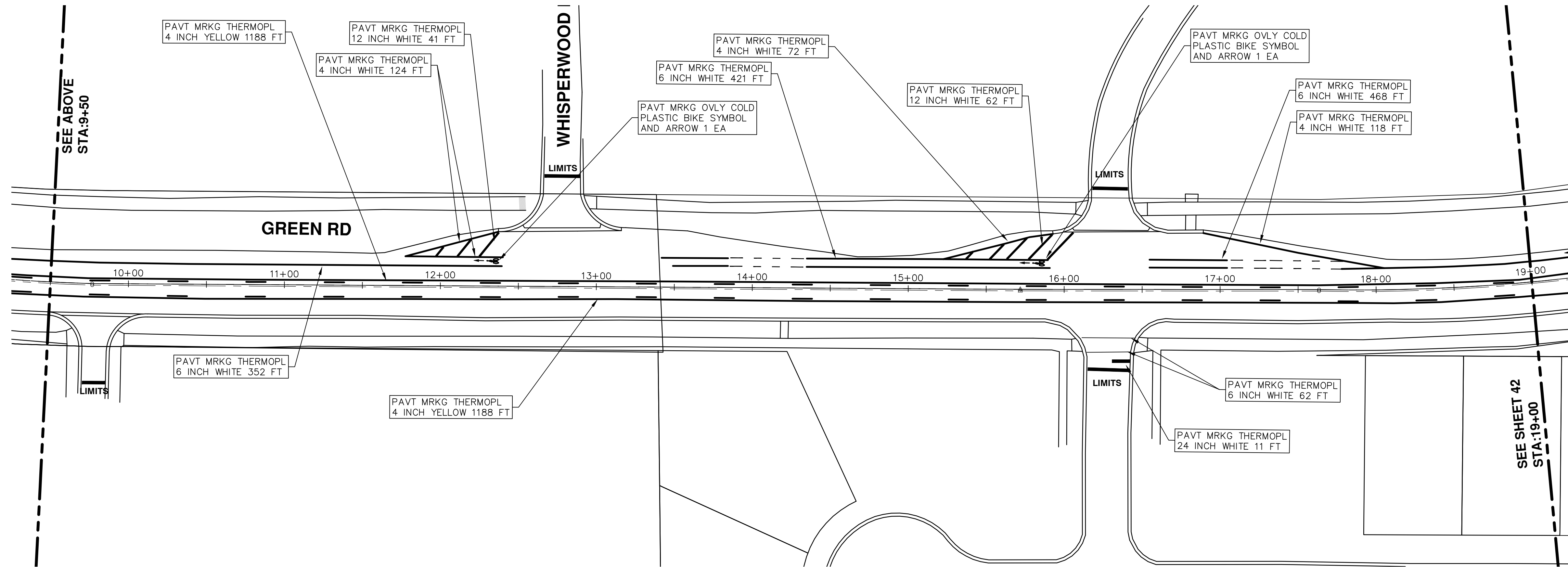
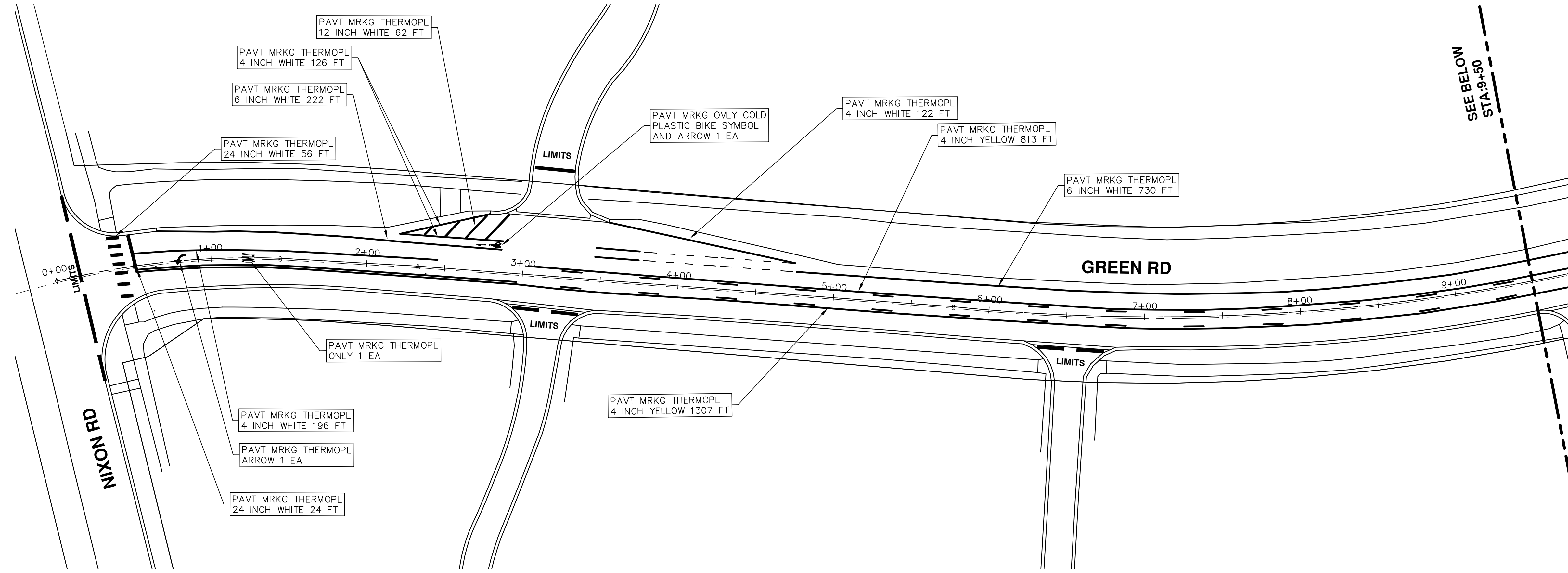

REV.	DESCRIPTION	DATE	DRAWN	CHECKED
02	ADDENDUM #3	3-15-2016	DAD	DAD
01	ADDENDUM #1	3-7-2016	DAD	DAD
00	BID SET	2-22-2016	GS AH JK	DAD

CITY OF ANN ARBOR
PUBLIC SERVICES
301 EAST HURON STREET
ANN ARBOR MI 48106-8647
www.a2gov.org

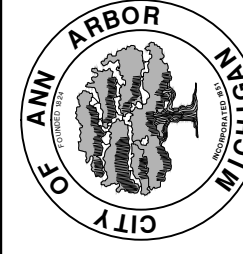

PROJECT MANAGEMENT - PUBLIC SERVICES - CITY OF ANN ARBOR
STREET RESURFACING - 2016
GREEN ROAD
PAVEMENT MARKINGS

SCALE PLAN: 1" = 40'
DRAWING No. 2016004-41

S:\Project Management\Drafting\autocad\2016004\Plan Production\2016004-GREEN RD.dwg Dwg Created: 24-Nov-15 - _a2 standard bw.stb - Plot Date: 15-Mar-16

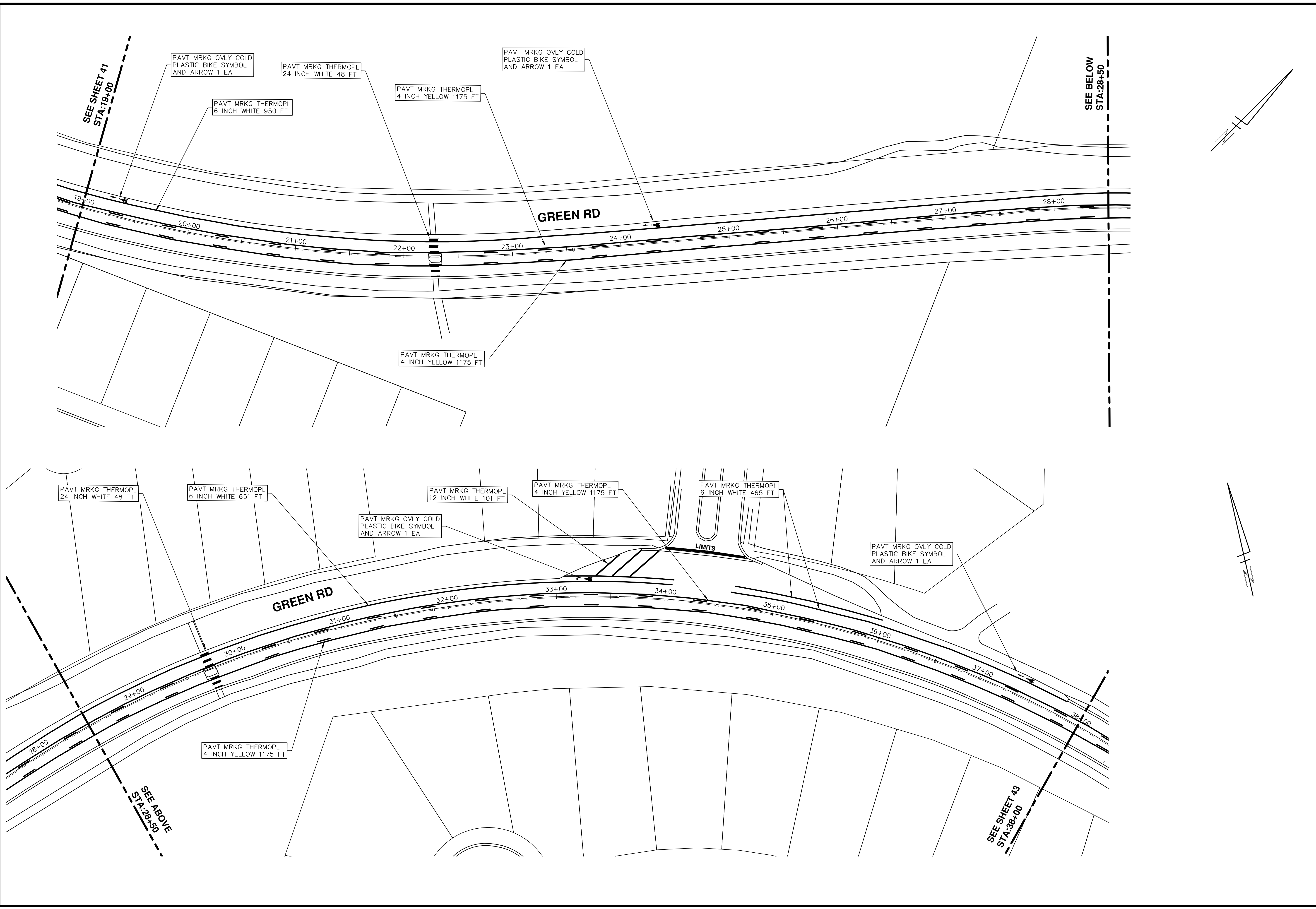

PROJECT MANAGEMENT - PUBLIC SERVICES - CITY OF ANN ARBOR
STREET RESURFACING - 2016
 GREEN ROAD
 PAVEMENT MARKINGS

SCALE PLAN: 1" = 40'

DRAWING No. 2016004-42

SHEET No. 42 OF 98

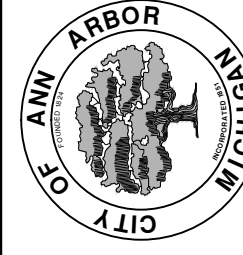

CITY OF ANN ARBOR
 PUBLIC SERVICES
 301 EAST HURON STREET
 ANN ARBOR, MI 48106-3667
 www.a2gov.org

REV.	DESCRIPTION	DATE	DRAWN	CHECKED
02	ADDENDUM #3	3-15-2016	DAD	DAD
01	ADDENDUM #1	3-7-2016	DAD	DAD
00	BID SET	2-22-2016	GS AH JK	DAD

811
 Know what's below.
 Call Before you dig.

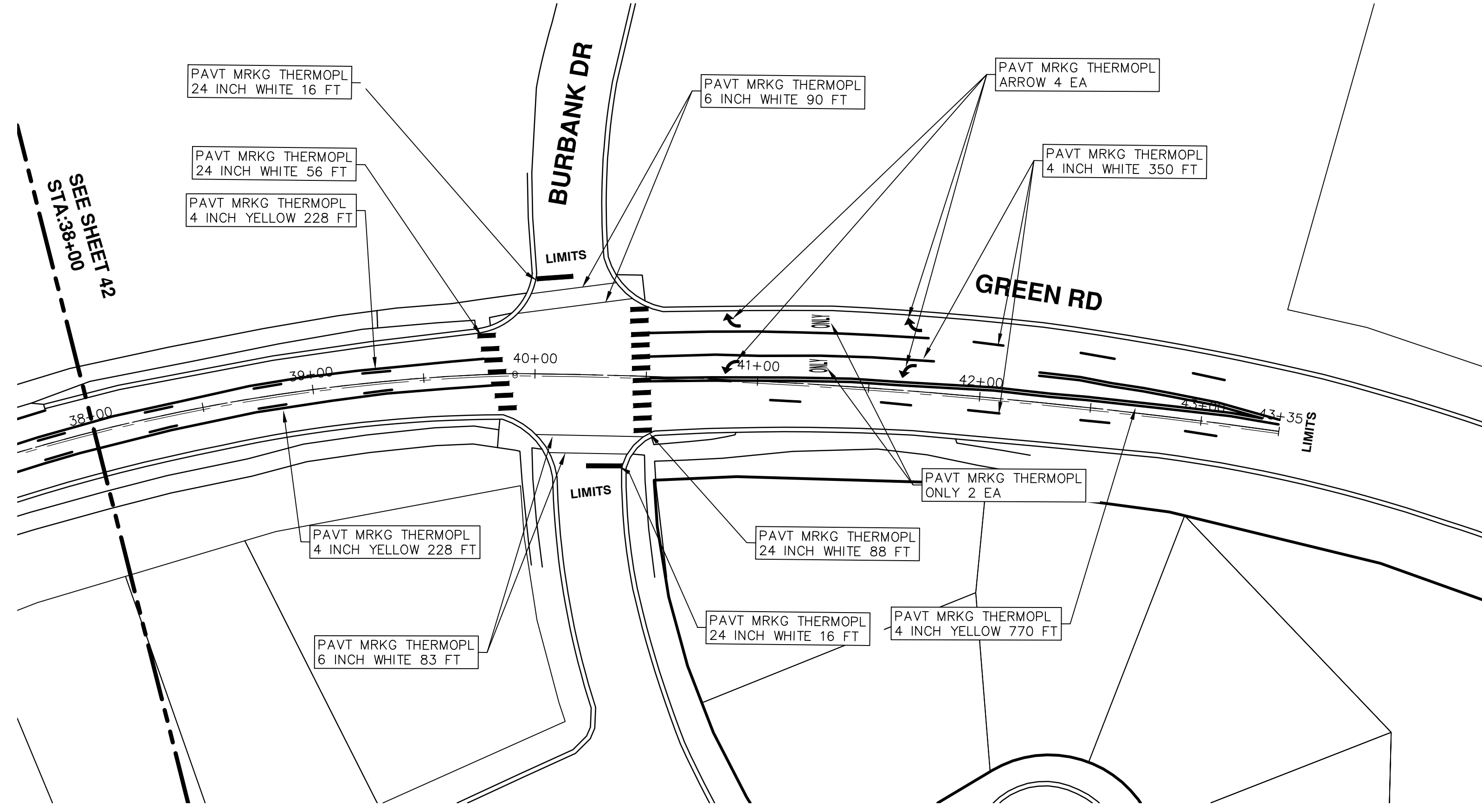

PROJECT MANAGEMENT - PUBLIC SERVICES - CITY OF ANN ARBOR
 STREET RESURFACING - 2016
 GREEN ROAD
 PAVEMENT MARKINGS

SCALE PLAN: 1" = 40'
 DRAWING No.
 2016004-43

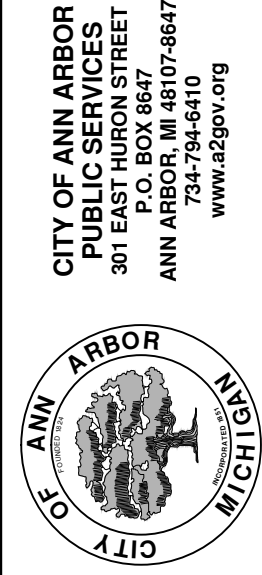

CITY OF ANN ARBOR
 PUBLIC SERVICES
 301 EAST HURON STREET
 ANN ARBOR, MI 48106-8647
 www.a2gov.org

REV.	DESCRIPTION	DATE	DRAWN	CHECKED
02	ADDENDUM #3	3-15-2016	DAD	DAD
01	ADDENDUM #1	3-7-2016	DAD	DAD
00	BID SET	2-22-2016	ISS AH UK	DAD

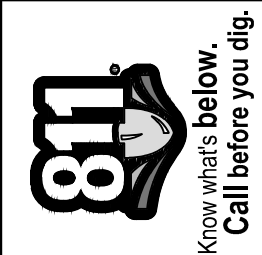



CITY OF ANN ARBOR PROJECT MANAGEMENT STREET RESURFACING - 2016 LOCATION: PONTIAC TRAIL

ITB No. 4422 FILE No. 2016004

CONSTRUCTION METHOD AND SEQUENCING

WORK ON THIS STREET INCLUDES, BUT IS NOT LIMITED TO, THE FOLLOWING ITEMS. COMPLETE THE WORK IN ACCORDANCE WITH THE PLANS AND SPECIFICATIONS, AS DIRECTED BY THE ENGINEER, AND UTILIZING PART WIDTH TWO (2) PHASE CONSTRUCTION. PERFORM THE WORK IN THE ORDER INDICATED BELOW UNLESS OTHERWISE AUTHORIZED OR DIRECTED BY THE ENGINEER. COMPLETE ITEMS 7 THRU 14 UTILIZING THE M.O.T. PLAN CURRENTLY IN PLACE, LANE CLOSURES, AND FLAG CONTROL OPERATIONS AS DIRECTED BY THE ENGINEER.

PHASE I

- IMPLEMENT MAINTENANCE OF TRAFFIC (M.O.T.) PLAN, AND INSTALL SOIL EROSION AND SEDIMENTATION CONTROL MEASURES.
- CONDUCT REMOVAL WORK RELATED TO PAVEMENT, DRAINAGE, AND CONCRETE ITEMS WITH EXCEPTION TO COLDMILLING.
- INSTALL PROPOSED DRAINAGE STRUCTURES, STORM SEWER, AND UNDERDRAIN AS REQUIRED.
- PERFORM ALL CONCRETE WORK, INCLUDING RESTORATION.
- TEMPORARY LOWER ALL STRUCTURE COVERS LOCATED WITHIN THE EXISTING PAVEMENT AREA, INCLUDING GATE AND MONUMENT BOXES.

PHASE II

- REPEAT ITEMS 1 THRU 5 IN THE ORDER SHOWN ABOVE.
- REMOVE 1.5 INCHES OF EXISTING HMA SURFACE BY COLDMILLING. THIS MAY INCLUDE GRANULAR BASE MATERIAL. DEPTH TO BE DETERMINED BY THE ENGINEER. PROOF ROLL WITH FULLY LOADED TRUCK.
- PERFORM ALL JOINT AND CRACK CLEANOUT. HMA/HAND PATCHING, UNDERCUTS AND/OR BASE REPAIRS AS REQUIRED.
- GRADE, SHAPE, AND COMPACT THE EXISTING BASE MATERIAL AS REQUIRED.
- ADJUST ALL STRUCTURE COVERS, INCLUDING GATE AND MONUMENT BOXES, TO THEIR FINISH ELEVATION.
- CLEAN PAVEMENT AND PLACE 1.5 INCH TOP COURSE HMA MIX (MAJOR STREETS) OVER ENTIRE STREET.
- CLEAN PAVEMENT AND PLACE HMA APPROACHES AS REQUIRED.
- CLEAN PAVEMENT AND COMPLETE ALL PAVEMENT MARKINGS.
- COMPLETE ALL MISCELLANEOUS CONSTRUCTION INCLUDING ALL CLEAN UP AND FINAL RESTORATION.
- REMOVE ALL TRAFFIC CONTROL DEVICES, AND MISS DIG FLAGS.

QUANTITIES			
Item Code	Item Description	Units	Quantity
2030011	Dr Structure, Rem	Ea	12.000
2030015	Sewer, Rem, Less than 24 inch	Ft	120.000
2047001	Curb, Gutter, and Curb and Gutter, Any Type, Rem	Ft	486.000
2047011	Sidewalk, Sidewalk Ramp, and Driveway Approach, Any Thickness, Rem	Syd	281.000
2057011	Grading, Sidewalk	Syd	164.000
2057011	Grading, Sidewalk Ramp	Syd	117.000
2057021	Subgrade Undercutting, Type IIA	Cyd	311.000
2087050	Erosion Control, Inlet Filter	Ea	24.000
4020987	Sewer, CI IV, 12 inch, Tr Det B	Ft	120.000
4030200	Dr Structure, 24 inch dia	Ea	12.000
4037001	Dr Structure Cover, Special	Ea	2.000
4037050	Dr Structure Cover, Type B, Modified	Ea	5.000
4037050	Dr Structure Cover, Type K, Modified	Ea	13.000
4037050	Dr Structure, Adj, Case 1, Modified	Ea	14.000
4037050	Dr Structure, Temp Lowering, Modified	Ea	11.000
5010003	Cold Milling HMA Surface	Ton	1,636.000
5010005	HMA Surface, Rem	Syd	54.000
5010057	HMA, 5E3	Ton	1,579.000
5010061	HMA, Approach	Ton	57.000
5017031	HMA, Wedging, 36A	Ton	8.000
6027021	Flowable Fill	Cyd	18.000
8037001	Detectable Warning Surface, Modified	Ft	90.000
8037010	Sidewalk Ramp, Conc, 6 inch, Modified	Sft	1050.000
8037010	Sidewalk with Integral Retaining Wall, 6 inch to 18 inch Height	Sft	20.000
8037010	Sidewalk, Conc, 4 inch, Modified	Sft	1475.000
8110049	Pav Mrkg, Ovy Cold Plastic, Direction Arrow Sym, Bike	Ea	10.000
8110058	Pav Mrkg, Ovy Cold Plastic, Bike, Small Sym	Ea	10.000
8110153	Pav Mrkg, Sprayable Thermopl, 4 inch, White	Ft	206.000
8110154	Pav Mrkg, Sprayable Thermopl, 4 inch, Yellow	Ft	7,708.000
8110155	Pav Mrkg, Sprayable Thermopl, 6 inch, White	Ft	9,246.000
8110197	Pav Mrkg, Thermopl, 6 inch, Crosswalk	Ft	725.000
8110218	Pav Mrkg, Thermopl, 24 inch, Stop Bar	Ft	233.000
8117001	Pav Mrkg, Thermopl, 24 inch, Crosswalk	Ft	184.000
8117050	Pav Mrkg, Thermopl, Lt Turn Arrow Sym	Ea	3.000
8117050	Pav Mrkg, Thermopl, Only	Ea	2.000
8120012	Barricade, Type III, High Intensity, Double Sided, Lighted, Fum	Ea	16.000
8120013	Barricade, Type III, High Intensity, Double Sided, Lighted, Oper	Ea	16.000
8120140	Lighted Arrow, Type C, Fum	Ea	1.000
8120141	Lighted Arrow, Type C, Oper	Ea	1.000
8120260	Plastic Drum, High Intensity, Lighted, Fum	Ea	172.000
8120261	Plastic Drum, High Intensity, Lighted, Oper	Ea	172.000
8120330	Sign, Portable, Changeable Message, Fum	Ea	3.000
8120331	Sign, Portable, Changeable Message, Oper	Ea	3.000
8120350	Sign, Type B, Temp, Prismatic, Fum	Sft	735.000
8120351	Sign, Type B, Temp, Prismatic, Oper	Sft	735.000
8127050	No Parking Sign	Ea	61.000
8167011	Slope Restoration	Syd	179.000

CONSTRUCTION KEY	
KEY	ASSOCIATED PAY ITEM(S)
AA	• Dr Structure, Adj, Case 1, Modified • Dr Structure, Adj, Case 2, Modified • Dr Structure, Temp Lowering, Modified
AB	• Dr Structure, Temp Lowering, Modified • Gate Box, Adj, Case 1 • Gate Box, Adj, Case 2 • Monument Box Adjust
ADST	• Dr Structure, Adj, Add Depth, Modified
AK	• Dr Structure, Adj, Case 1, Modified
C4	• Sidewalk, Sidewalk Ramp, and Driveway Approach, Any Thickness, Rem • Grading, Sidewalk • Sidewalk, Conc, 4 inch, Modified
C4HE	• Sidewalk, Sidewalk Ramp, and Driveway Approach, Any Thickness, Rem • Grading, Sidewalk • Cement • Sidewalk, Conc, 4 inch, Modified
C6	• Sidewalk, Sidewalk Ramp, and Driveway Approach, Any Thickness, Rem • Grading, Sidewalk • Grading, Sidewalk Ramp • Detectable Warning Surface, Modified • Sidewalk Ramp, Conc, 6 inch, Modified • Sidewalk, Conc, 6 inch, Modified
C8	• Grading, Driveway Approach • Driveway, Nonreinf Conc, 8 inch, Modified
CHE	• Sidewalk, Sidewalk Ramp, and Driveway Approach, Any Thickness, Rem • Grading, Driveway Approach • Grading, Sidewalk • Grading, Sidewalk Ramp • Cement • Driveway, Nonreinf Conc, 6 inch, Modified • Driveway, Nonreinf Conc, 8 inch, Modified • Detectable Warning Surface, Modified • Sidewalk Ramp, Conc, 6 inch, Modified • Sidewalk, Conc, 6 inch, Modified
C/G	• Curb, Gutter, and Curb and Gutter, Any Type, Rem • Curb and Gutter, Conc
C/GHE	• Curb, Gutter, and Curb and Gutter, Any Type, Rem • Cement • Driveway Opening, Conc, Det M, Modified
CP	• Grading, Sidewalk • Sidewalk, Conc, 4 inch, Modified
CR	• Sidewalk, Sidewalk Ramp, and Driveway Approach, Any Thickness, Rem • Dr Structure, Rem
DS	• Sewer, Rem, Less than 24 inch • Dr Structure, 24 inch dia
DSDI	• Dr Structure, Rem • Sewer, Rem, Less than 24 inch • Dr Structure, Double Inlet
PT	• Dr Structure, Point • Dr Structure Cover, Type B • Dr Structure Cover, Type B, Special
RRA	• Dr Structure, Adj, Case 1, Modified • Dr Structure, Temp Lowering, Modified
RRK	• Dr Structure Cover, Type K • Dr Structure, Adj, Case 1, Modified
RS	• Dr Structure, Reconstruct
TYPE II	• Plastic Drum, High Intensity, Lighted, Fum • Plastic Drum, High Intensity, Lighted, Oper
TYPE III	• Barricade, Type III, High Intensity, Double Sided, Lighted, Fum • Barricade, Type III, High Intensity, Double Sided, Lighted, Oper

LEGEND	
SYMBOL	DESCRIPTION
⊙	EXISTING SANITARY SEWER MANHOLE
⊕	EXISTING STORM SEWER MANHOLE
⊗	EXISTING WATER MAIN VALVE IN WELL
+	WATER MAIN GATE VALVE IN BOX
⊕	FIRE HYDRANT
⊙	MICHCON GAS CO. VALVE BOX/WELL
⊕	AMERITECH TELEPHONE VAULT
⊙	ELECTRIC MANHOLE
⊕	SOIL BORING
□	EXISTING STORM SEWER INLET
⊕	MONUMENT BOX
▬	REMOVE AND REPLACE CONC. SIDEWALK
▬	PLACE CONCRETE SIDEWALK
▬	REMOVE & REPLACE CONC. CURB & GUTTER
▬	CONSTRUCTION LIMITS
▬	6" WRAPPED UNDERDRAIN
▬	REMOVE CONCRETE SIDEWALK
▬	SUBGRADE UNDERCUT

QUANTITIES				
Sign, Type B, Temp, Prismatic				
Quantity	Sign Code	Description	Area (sft)	Total
40.0	D3-1	Street Name Sign	4.000	160.000
1.0	M4-10L	Detour Arrow (Left) Sign	6.000	6.000
1.0	M4-10R	Detour Arrow (Right) Sign	6.000	6.000
1.0	M4-8a	End Detour Sign	3.000	3.000
5.0	M4-9L	Detour Sign (w/Left Arrow)	5.000	25.000
2.0	M4-9R	Detour Sign (w/Right Arrow)	5.000	10.000
7.0	M4-9S	Detour Sign (w/Thru Arrow)	5.000	35.000
4.0	R11-4	Road Closed Sign ("Road Closed To Thru Traffic")	12.500	50.000
11.0	R6-1L	One Way (Left) Sign	3.000	33.000
11.0	R6-1R	One Way (Right) Sign	3.000	33.000
4.0	SP-1	Special Sign	20.000	80.000
14.0	W20-1	Road Work Ahead Sign	9.000	126.000
1.0	W20-2	Detour Ahead Sign	9.000	9.000
6.0	W20-3	Road Closed Ahead Sign	9.000	54.000
1.0	W20-4	One Lane Road Sign ("One Lane Road Ahead")	9.000	9.000
		TOTAL		639.000

NOTES:

FOR PROTECTION OF UNDERGROUND UTILITIES AND IN CONFORMANCE WITH PUBLIC ACT 174 OF 2013, THE CONTRACTOR SHALL CALL 811 OR 1-800-482-7171 A MINIMUM OF THREE FULL WORKING DAYS, EXCLUDING SATURDAYS, SUNDAYS, AND HOLIDAYS, PRIOR TO BEGINNING EACH EXCAVATION IN AREAS WHERE PUBLIC UTILITIES HAVE NOT BEEN PREVIOUSLY LOCATED. MEMBERS WILL THUS BE ROUTINELY NOTIFIED. THIS DOES NOT RELIEVE THE CONTRACTOR OF THE RESPONSIBILITY OF NOTIFYING UTILITY OWNERS WHO MAY NOT BE A PART OF THE "MISS DIG" ALERT SYSTEM.

THE UNDERGROUND LOCATIONS SHOWN FOR NATURAL GAS, TELEPHONE, ELECTRICAL POWER, CABLE TV AND FIBER OPTIC LINES ARE APPROXIMATE. THE CITY OF ANN ARBOR ASSUMES NO RESPONSIBILITY FOR THEIR ACCURATE REPRESENTATION IN THIS DRAWING. MISS DIG MUST BE CONTACTED PRIOR TO CONSTRUCTION TO LOCATE THESE UTILITIES.

THE IMPROVEMENTS COVERED BY THESE PLANS SHALL BE PERFORMED IN ACCORDANCE WITH MICHIGAN DEPARTMENT OF TRANSPORTATION (MDOT) 2012 STANDARD SPECIFICATIONS FOR CONSTRUCTION, INCLUDING REFERENCED MDOT PUBLICATIONS, AND THE PROJECT CONTRACT DOCUMENTS.



PROJECT MANAGEMENT SERVICES UNIT
CITY OF ANN ARBOR PUBLIC SERVICES
301 EAST HURON STREET, P.O. BOX 8647
ANN ARBOR, MICHIGAN 48107-8647
734-794-6410 www.a2gov.org

S:\Project Management\Drafting\autocad\2016004\Plan Production\2016004-PONTIAC TR.dwg Dwg Created: 24-Nov-15 15:02 standard bw.stb - Plot Date: 15-Mar-16

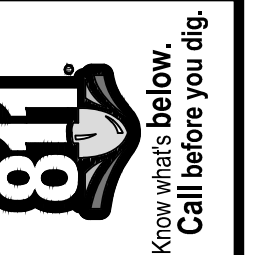

PROJECT MANAGEMENT - PUBLIC SERVICES - CITY OF ANN ARBOR
STREET RESURFACING - 2016
PONTIAC TRAIL
DRAWING No. 2016004-44

TRAFFIC CONTROL SIGN		
TAG	SIGN	NUM.
①		D3-1 M4-9S 30x24
②		D3-1 M4-9R 30x24
③		D3-1 M4-9L 30x24
⑥		D3-1 M4-8a 24x18
⑧		SPECIAL 48x60
⑩		W20-2 48x48
⑫		SPECIAL 48x60

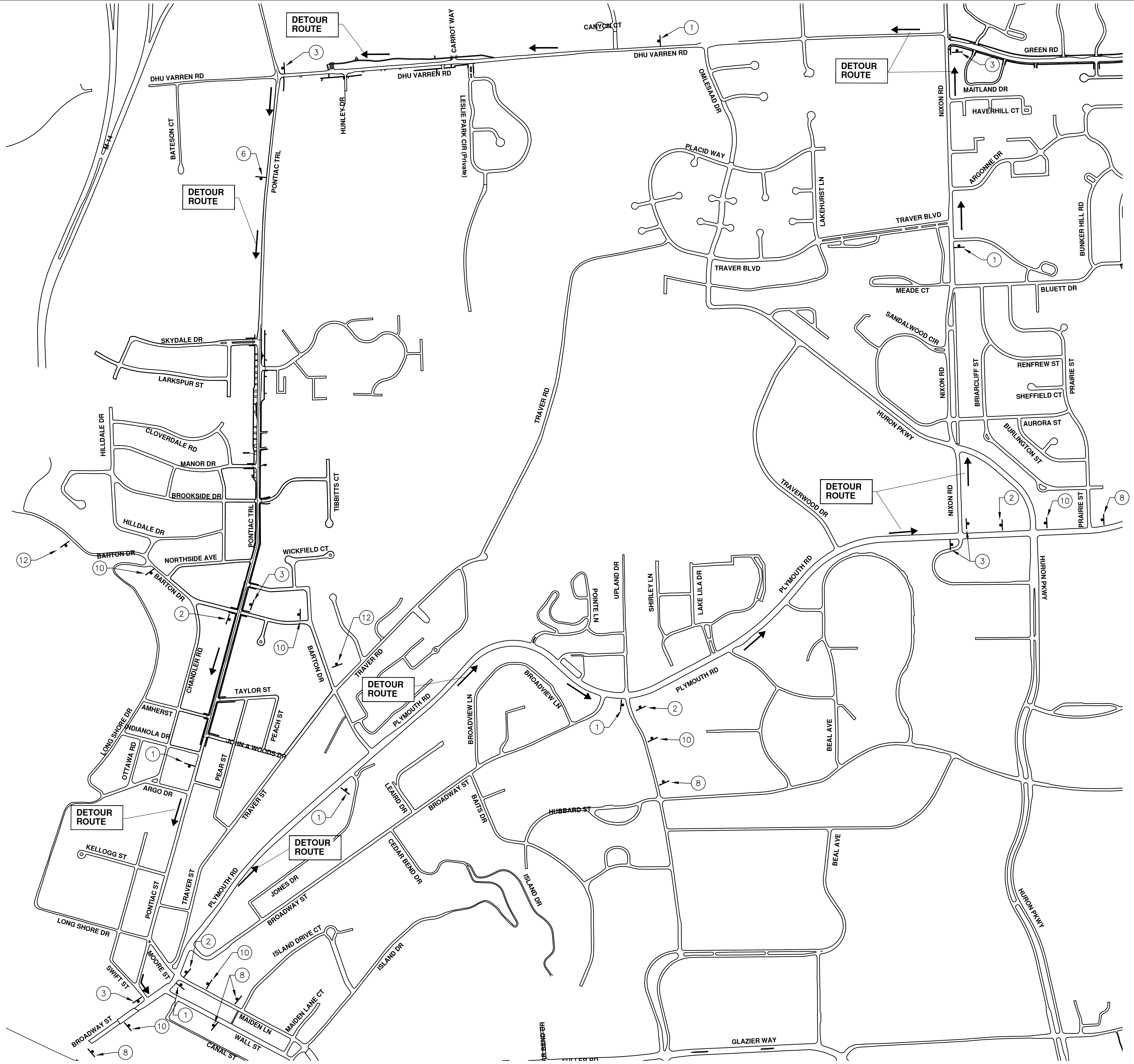

REV.	DATE	DESCRIPTION
02	3-15-2016	ADDENDUM #3
01	3-7-2016	ADDENDUM #1
00	2-22-2016	BID SET

CITY OF ANN ARBOR
PUBLIC SERVICES
301 EAST HURON STREET
ANN ARBOR, MI 48106-6647
www.a2gov.org

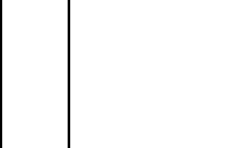

PROJECT MANAGEMENT - PUBLIC SERVICES - CITY OF ANN ARBOR
STREET RESURFACING - 2016
PONTIAC TRAIL
DETOUR

S:\Project Management\Drafting\autocad\2016004\Plan Production\2016004-PONTIAC TR.dwg Dwg Created: 24-Nov-15 - _a2 standard bw.stb - Plot Date: 15-Mar-16

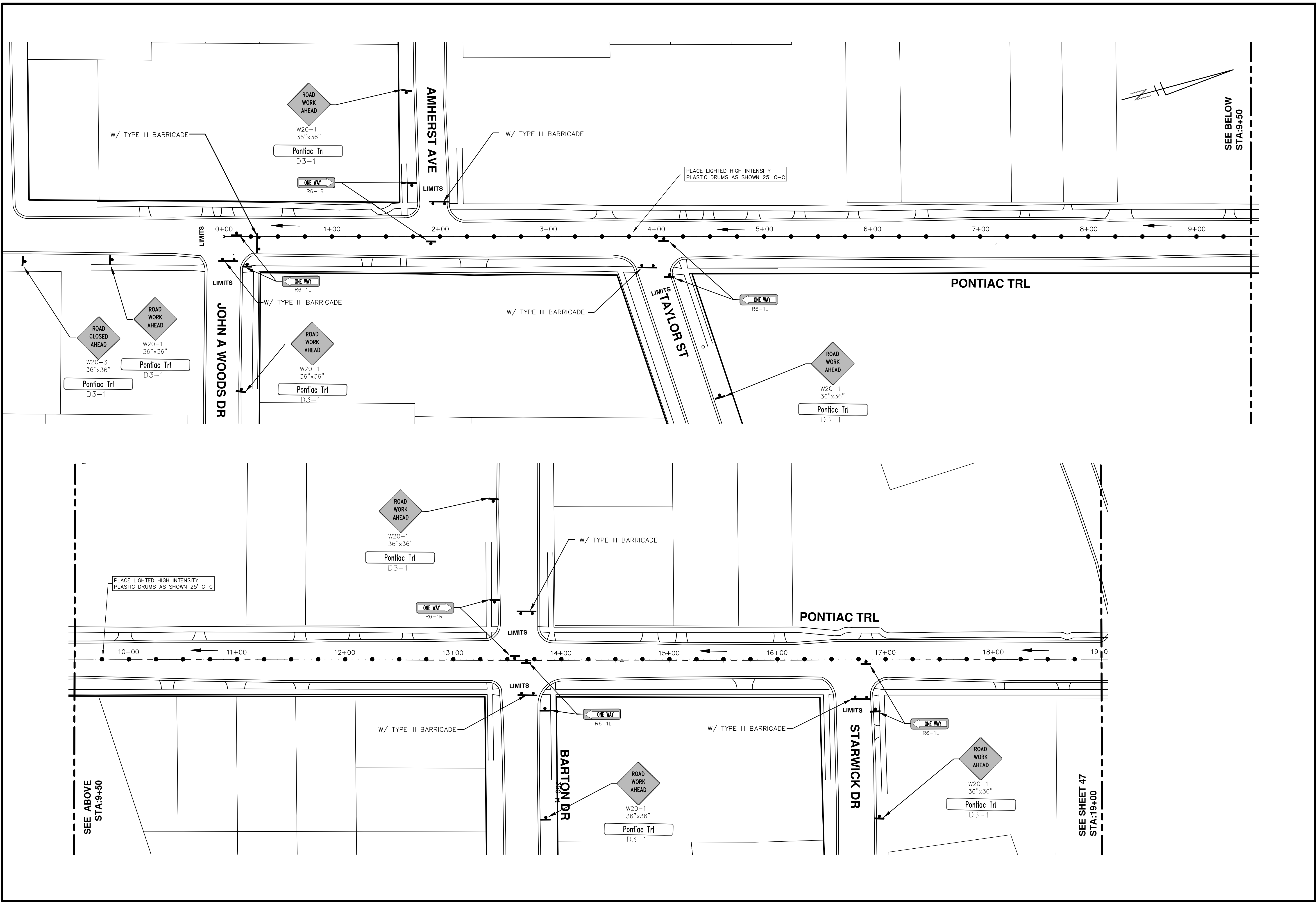

PROJECT MANAGEMENT - PUBLIC SERVICES - CITY OF ANN ARBOR
STREET RESURFACING - 2016
 PONTIAC TRAIL
 TRAFFIC CONTROL

SCALE PLAN: 1" = 40'
 DRAWING No. 2016004-46

811
 Know what's below.
 Call Before you dig.

REV.	DESCRIPTION	DATE	DRAWN	CHECKED
02	ADDENDUM #3	3-15-2016	DAD	DAD
01	ADDENDUM #1	3-7-2016	DAD	DAD
00	BID SET	2-22-2016	GS AH JK	DAD

CITY OF ANN ARBOR
 PUBLIC SERVICES
 301 EAST HURON STREET
 P.O. BOX 8647
 ANN ARBOR MI 48107-8647
 www.a2gov.org

CITY OF ANN ARBOR MICHIGAN

S:\Project Management\Drafting\autocad\2016004\Plan Production\2016004-PONTIAC TR.dwg Dwg Created: 24-Nov-15 - _a2 standard bw.stb - Plot Date: 15-Mar-16

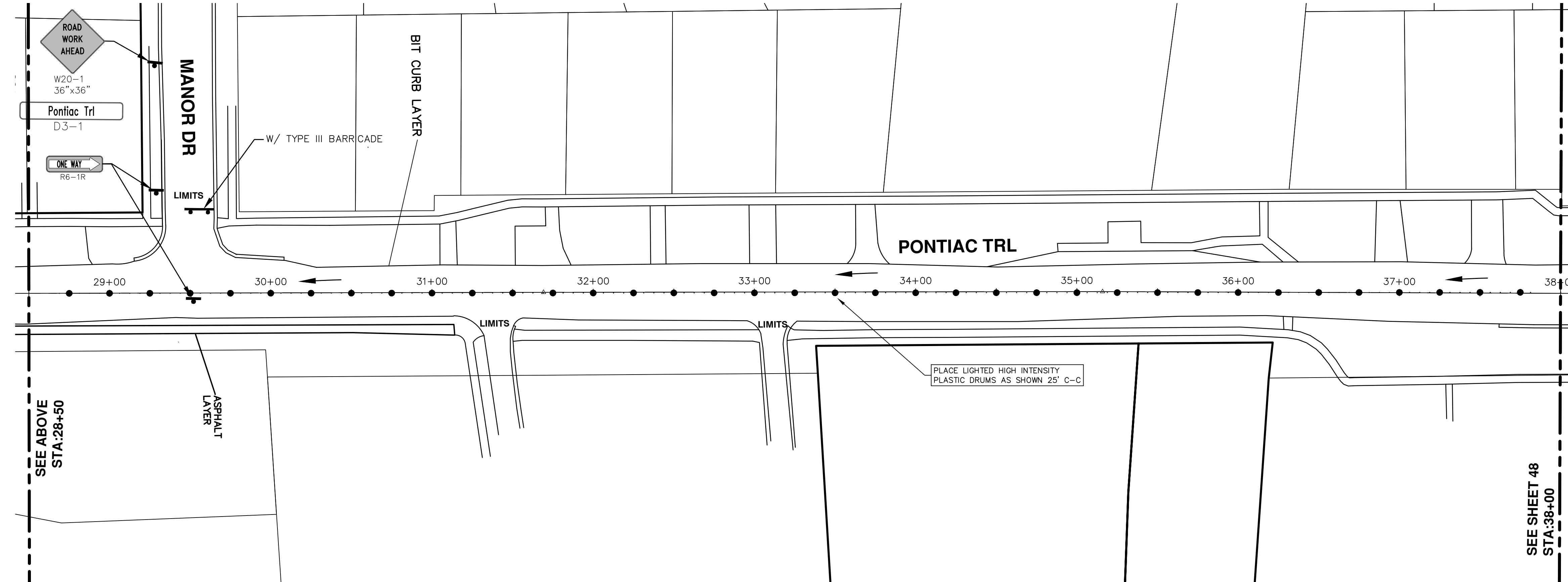
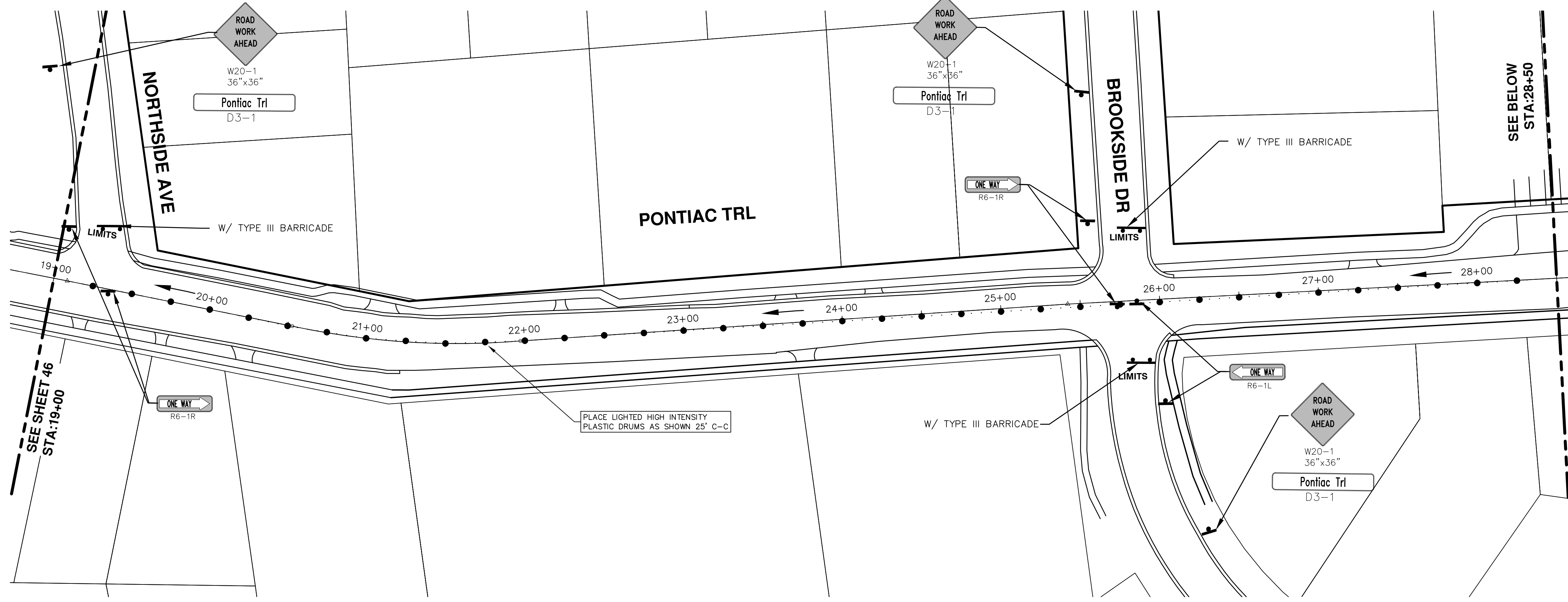

REV.	DESCRIPTION	DATE	DRAWN	CHECKED
02	ADDENDUM #3	3-15-2016	DAD	DAD
01	ADDENDUM #1	3-7-2016	DAD	DAD
00	BID SET	2-22-2016	GS AH UK	DAD

CITY OF ANN ARBOR
PUBLIC SERVICES
301 EAST HURON STREET
ANN ARBOR MI 48106-8647
www.a3gov.org



PROJECT MANAGEMENT - PUBLIC SERVICES - CITY OF ANN ARBOR
STREET RESURFACING - 2016
PONTIAC TRAIL
TRAFFIC CONTROL

SCALE PLAN: 1" = 40'
DRAWING No. 2016004-47

S:\Project Management\Drafting\autocad\2016004\Plan Production\2016004-PONTIAC TR.dwg Dwg Created: 24-Nov-15 - Plot Date: 15-Mar-16

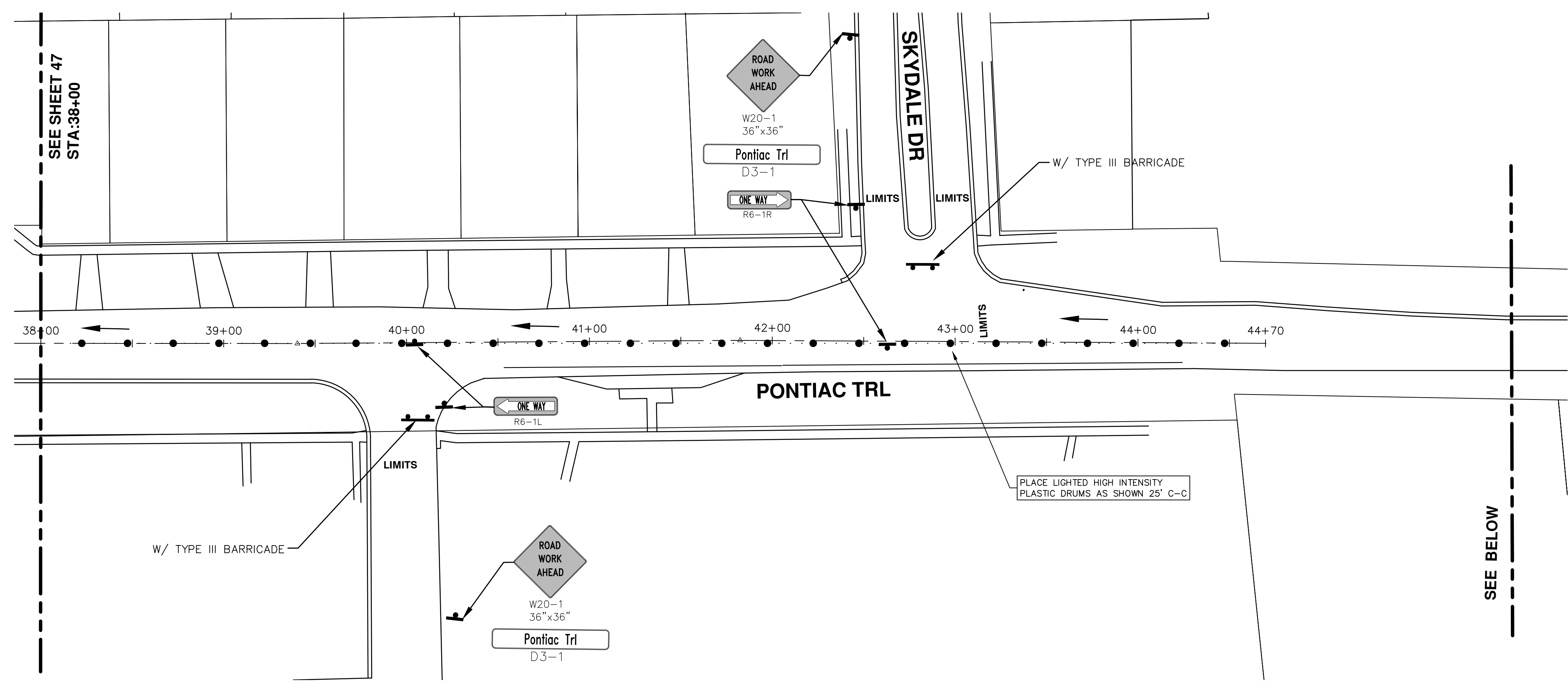
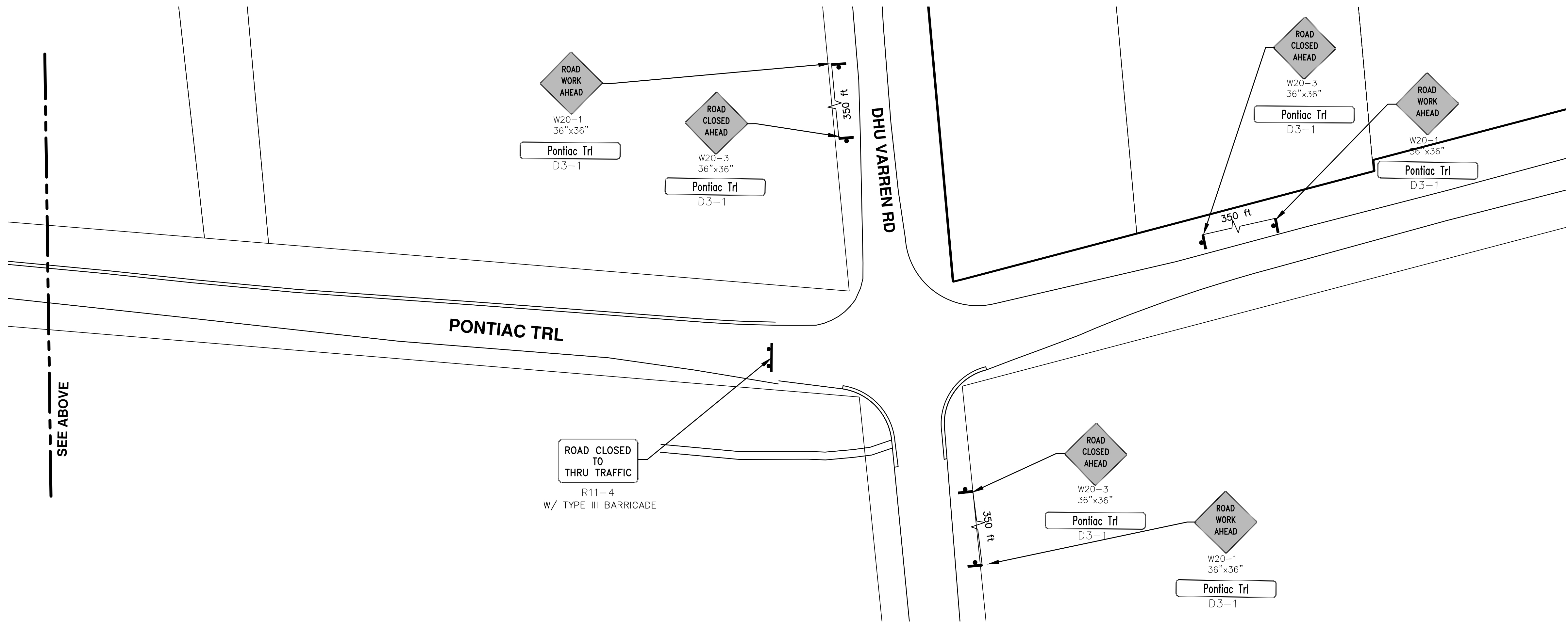

PROJECT MANAGEMENT - PUBLIC SERVICES - CITY OF ANN ARBOR
STREET RESURFACING - 2016
PONTIAC TRAIL
TRAFFIC CONTROL

SCALE PLAN: 1" = 40'
 DRAWING No. 2016004-48
 SHEET No. 48 OF 98

CITY OF ANN ARBOR
PUBLIC SERVICES
 301 EAST HURON STREET
 P.O. BOX 8647
 ANN ARBOR, MI 48108-8647
 www.a2gov.org

REV.	DESCRIPTION	DATE	DRAWN	CHECKED
02	ADDENDUM #3	3-15-2016	DAD	DAD
01	ADDENDUM #1	3-7-2016	DAD	DAD
00	BID SET	2-22-2016	SS AH JK	DAD



S:\Project Management\Drafting\autocad\2016004\Plan Production\2016004-PONTIAC TR.dwg Dwg Created: 24-Nov-15 - _a2 standard bw.stb - Plot Date: 15-Mar-16

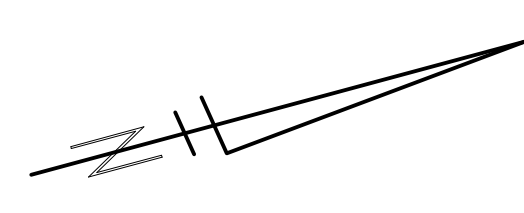
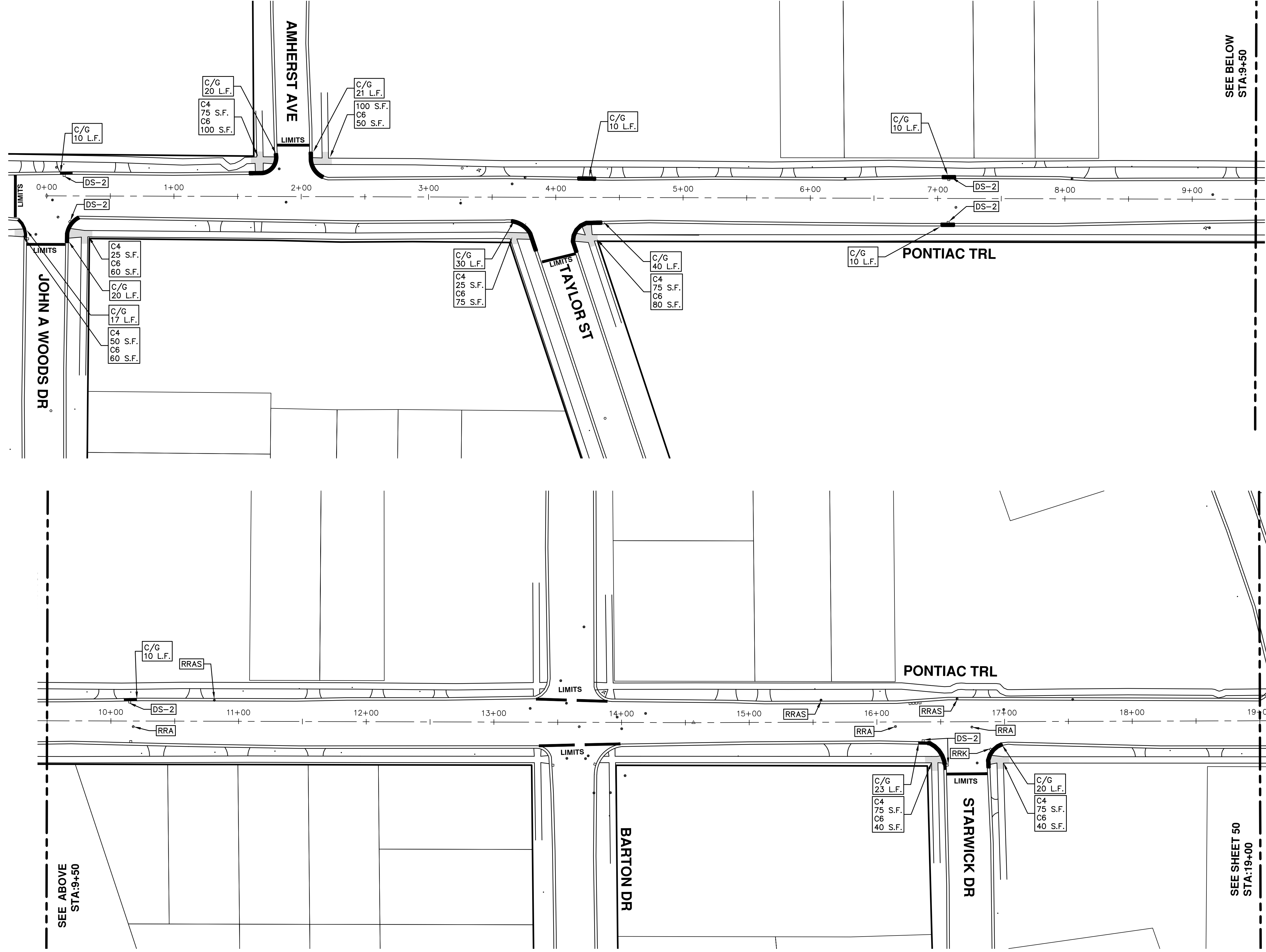

CITY OF ANN ARBOR
 PUBLIC SERVICES
 301 EAST HURON STREET
 P.O. BOX 8647
 ANN ARBOR MI 48106-8647
 www.a2gov.org

REV.	DESCRIPTION	DATE	DRAWN	CHECKED
02	ADDENDUM #3	3-15-2016	DAD	DAD
01	ADDENDUM #1	3-7-2016	DAD	DAD
00	BID SET	2-22-2016	SS AH JK	DAD

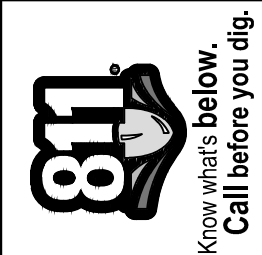

S:\Project Management\Drafting\autocad\2016004\Plan Production\2016004-PONTIAC TR.dwg Dwg Created: 24-Nov-15 - _a2 standard bw.stb - Plot Date: 15-Mar-16

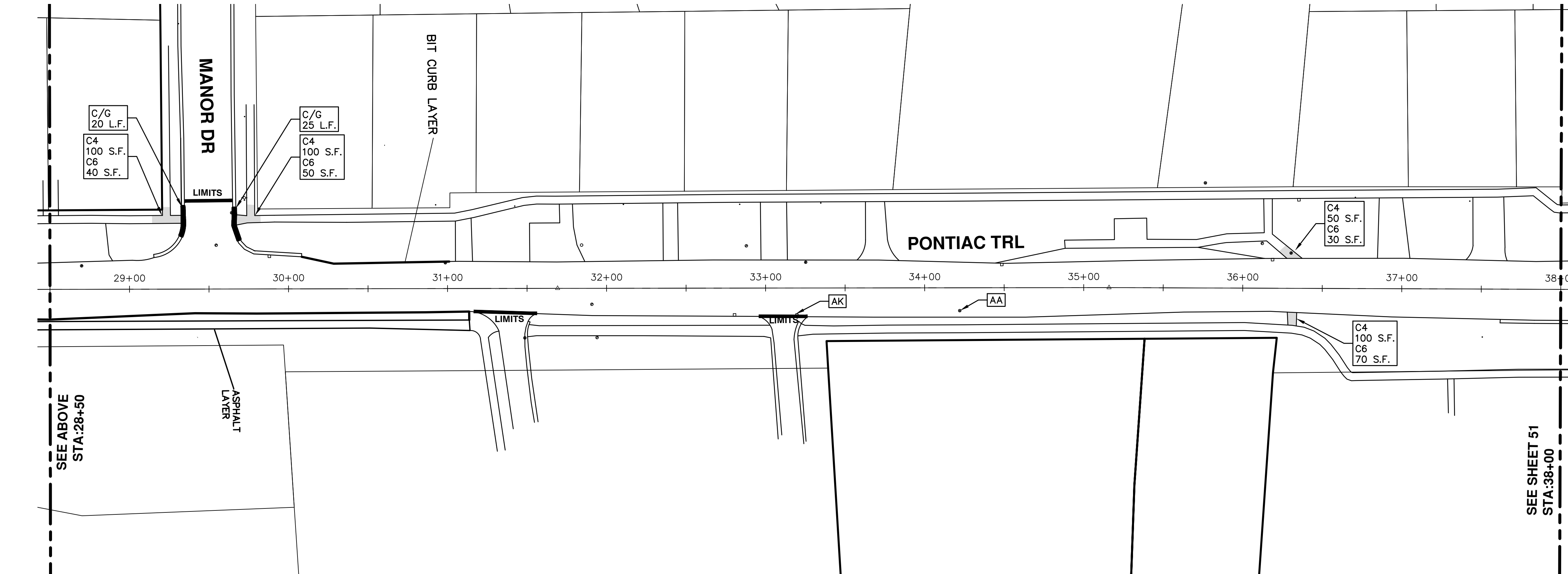
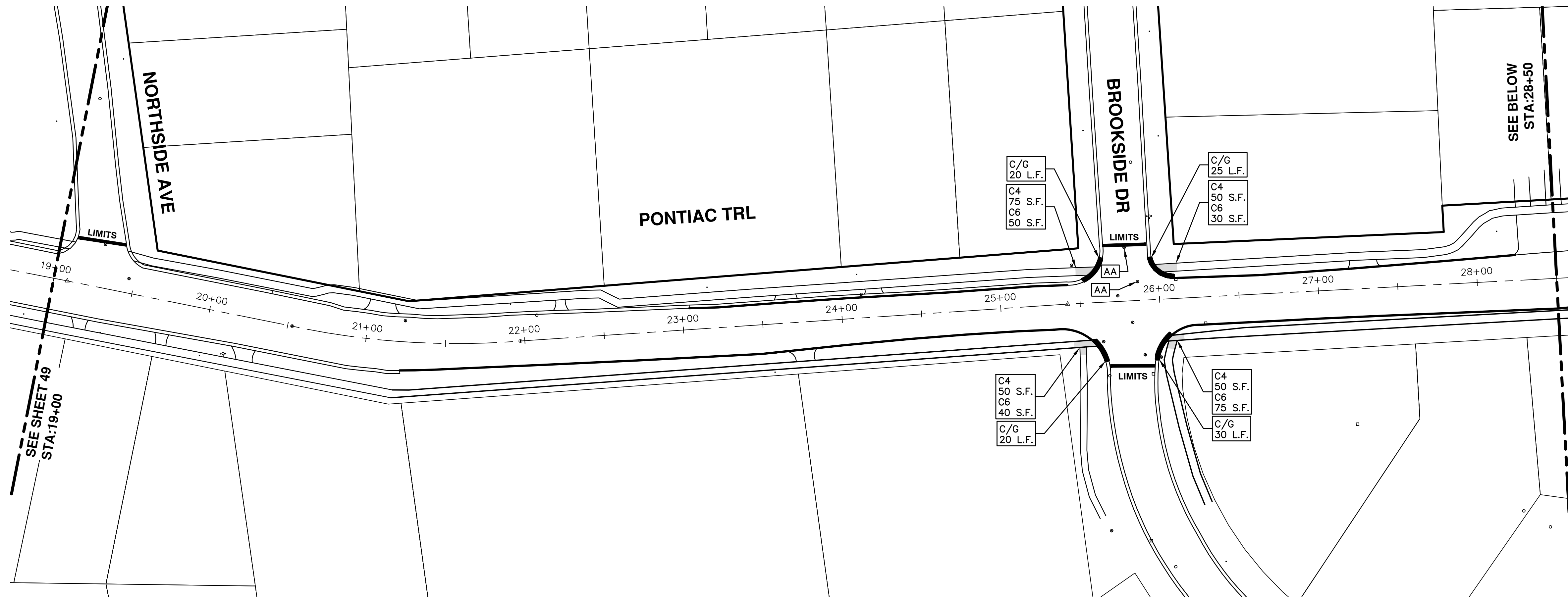

REV.	DESCRIPTION	DATE	DRAWN	CHECKED
02	ADDENDUM #3	3-15-2016	DAD	DAD
01	ADDENDUM #1	3-7-2016	DAD	DAD
00	BID SET	2-22-2016	GS AH JK	DAD

CITY OF ANN ARBOR
 PUBLIC SERVICES
 301 EAST HURON STREET
 ANN ARBOR, MI 48106-0667
 www.a2gov.org



PROJECT MANAGEMENT - PUBLIC SERVICES - CITY OF ANN ARBOR
STREET RESURFACING - 2016
 PONTIAC TRAIL
 RESURFACING

SCALE PLAN: 1" = 40'
 DRAWING No. 2016004-50

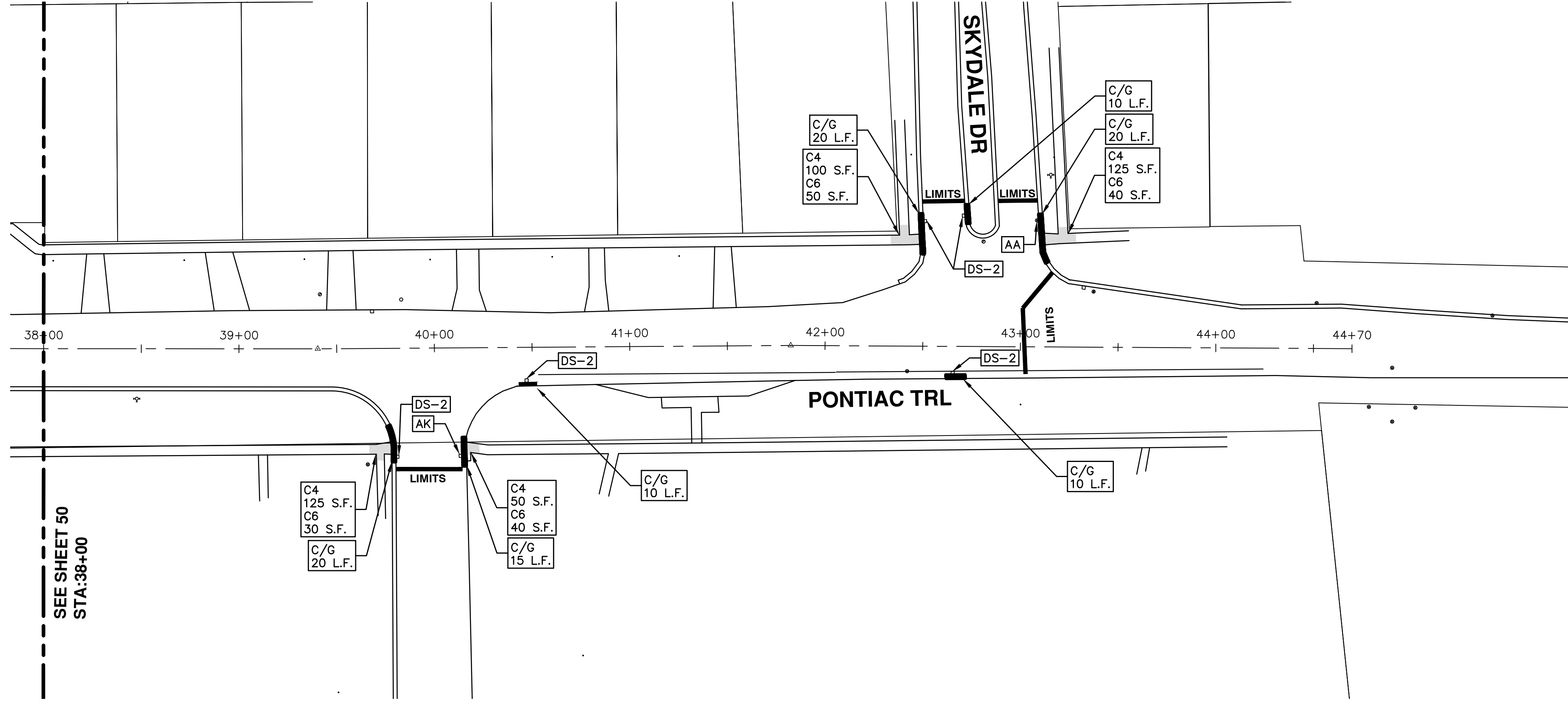

PROJECT MANAGEMENT - PUBLIC SERVICES - CITY OF ANN ARBOR
STREET RESURFACING - 2016
PONTIAC TRAIL
RESURFACING

SCALE PLAN: 1" = 40'
 DRAWING No. 2016004-51

CITY OF ANN ARBOR
 PUBLIC SERVICES
 301 EAST HURON STREET
 ANN ARBOR, MI 48106-3667
 www.a2gov.org

REV.	DESCRIPTION	DATE	DRAWN	CHECKED
02	ADDENDUM #3	3-15-2016	DAD	DAD
01	ADDENDUM #1	3-7-2016	DAD	DAD
00	BID SET	2-22-2016	GS AH JK	DAD

811
 Know what's below.
 Call before you dig.

S:\Project Management\Drafting\autocad\2016004\Plan Production\2016004-PONTIAC TR.dwg Dwg Created: 24-Nov-15 - Plot Date: 15-Mar-16

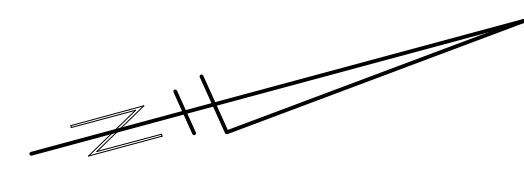
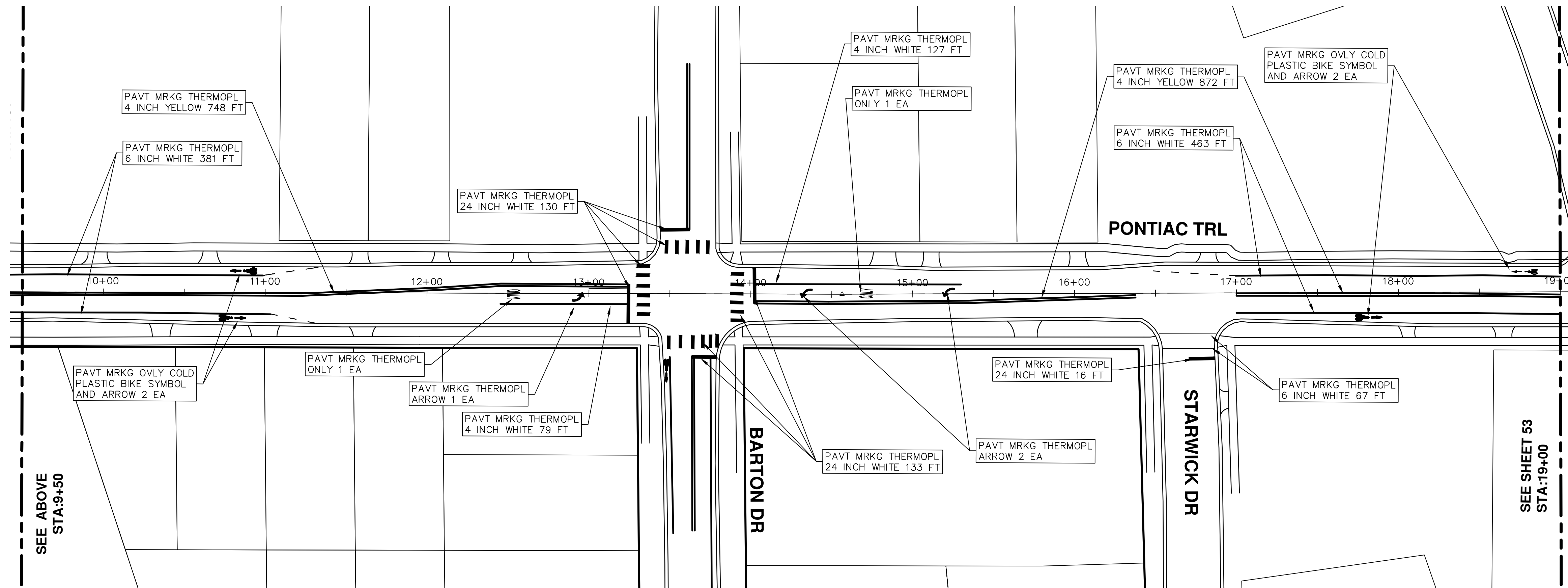
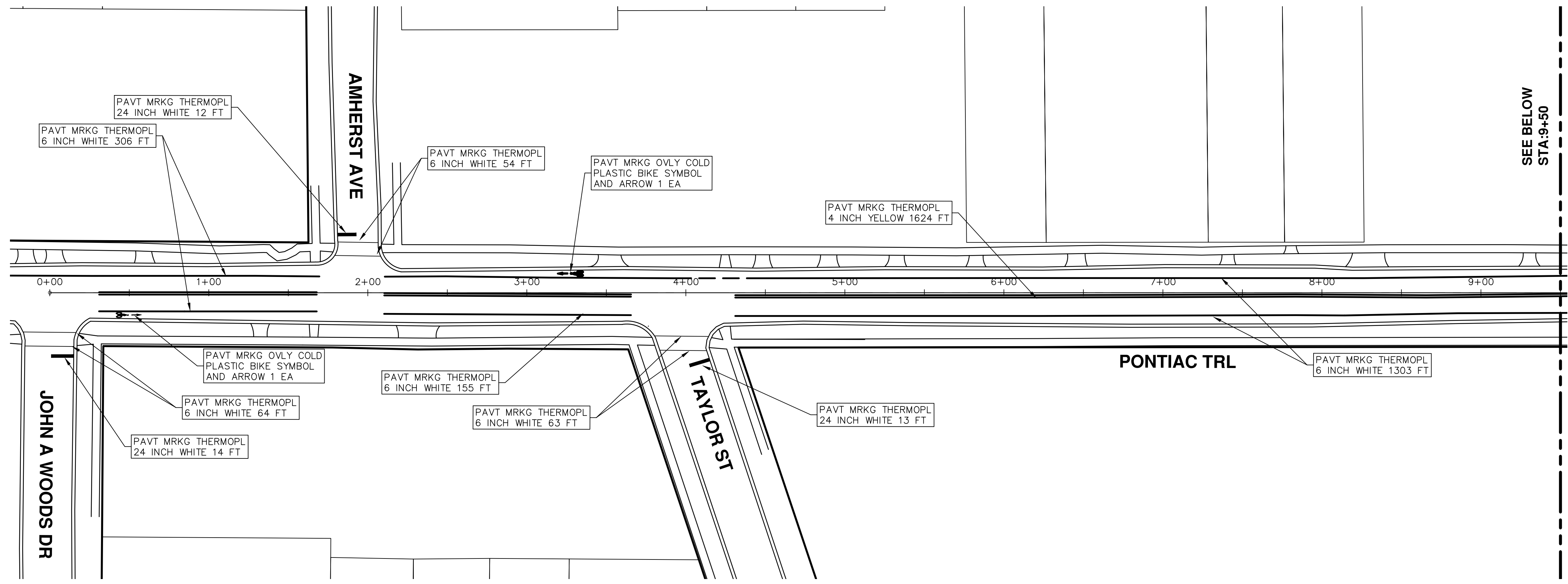

REV.	DESCRIPTION	DATE	DRAWN	CHECKED
02	ADDENDUM #3	3-15-2016	DAD	DAD
01	ADDENDUM #1	3-7-2016	DAD	DAD
00	BID SET	2-22-2016	GS AH JK	DAD

CITY OF ANN ARBOR
PUBLIC SERVICES
301 EAST HURON STREET
ANN ARBOR MI 48106-8647
www.a2gov.org



PROJECT MANAGEMENT - PUBLIC SERVICES - CITY OF ANN ARBOR
STREET RESURFACING - 2016
PONTIAC TRAIL
PAVEMENT MARKINGS

SCALE PLAN: 1" = 40'
DRAWING No. 2016004-52

S:\Project Management\Drafting\autocad\2016004\Plan Production\2016004-PONTIAC TR.dwg Dwg Created: 24-Nov-15 - _a2 standard bw.stb - Plot Date: 15-Mar-16

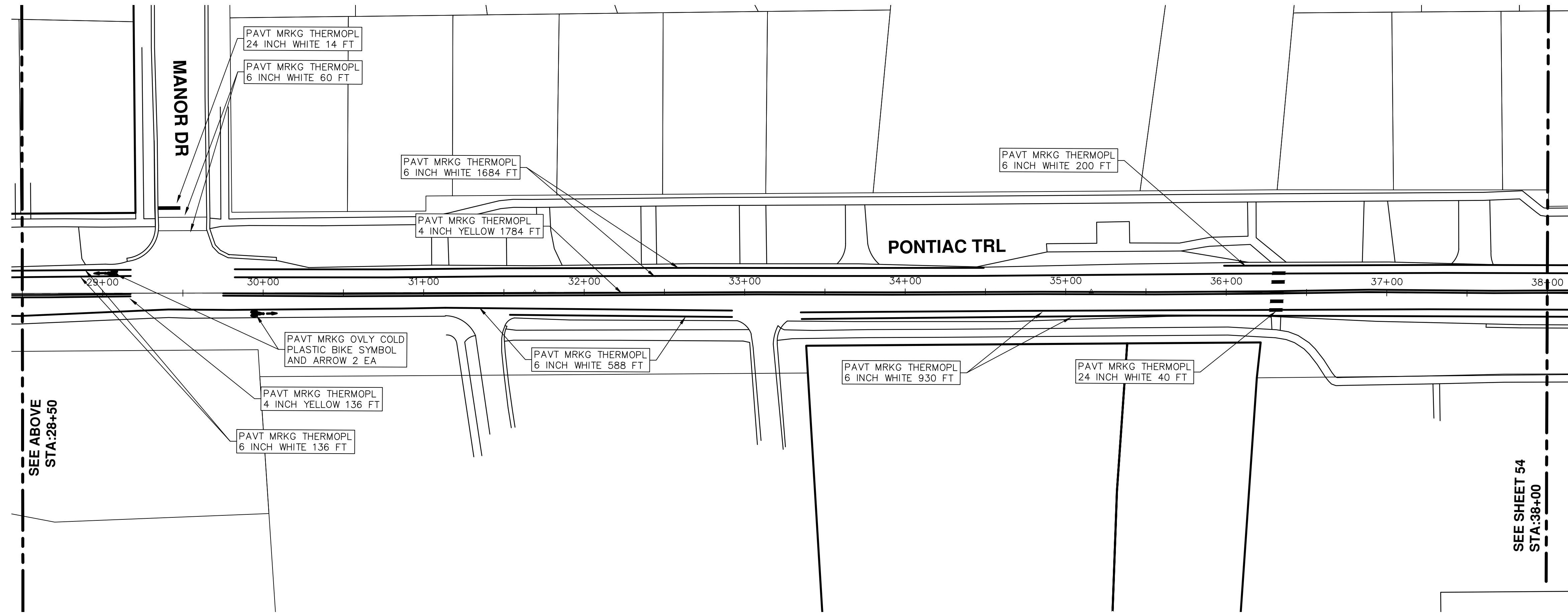
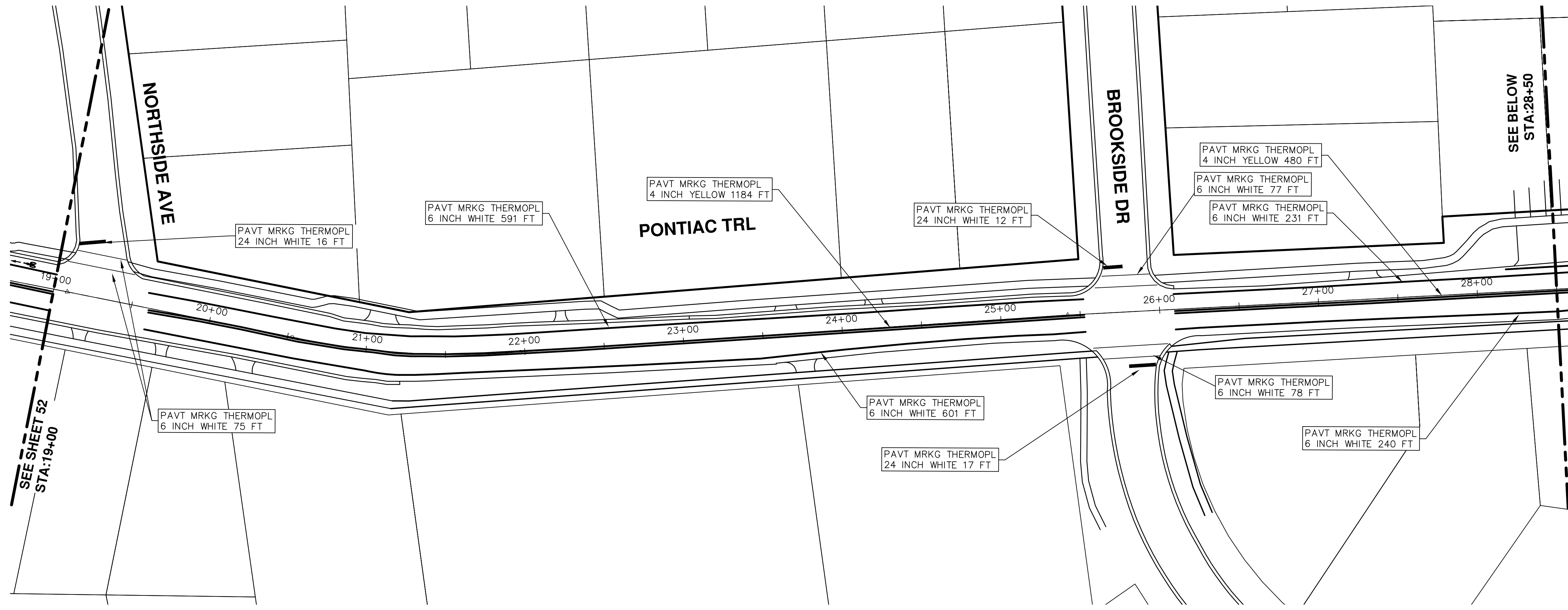

REV.	DESCRIPTION	DATE	DRAWN	CHECKED
02	ADDENDUM #3	3-15-2016	DAD	DAD
01	ADDENDUM #1	3-7-2016	DAD	DAD
00	BID SET	2-22-2016	SS AH JK	DAD

CITY OF ANN ARBOR
PUBLIC SERVICES
301 EAST HURON STREET
ANN ARBOR MI 48106-8647
www.a2gov.org



PROJECT MANAGEMENT - PUBLIC SERVICES - CITY OF ANN ARBOR
STREET RESURFACING - 2016
PONTIAC TRAIL
PAVEMENT MARKINGS

SCALE PLAN: 1" = 40'
DRAWING No. 2016004-53

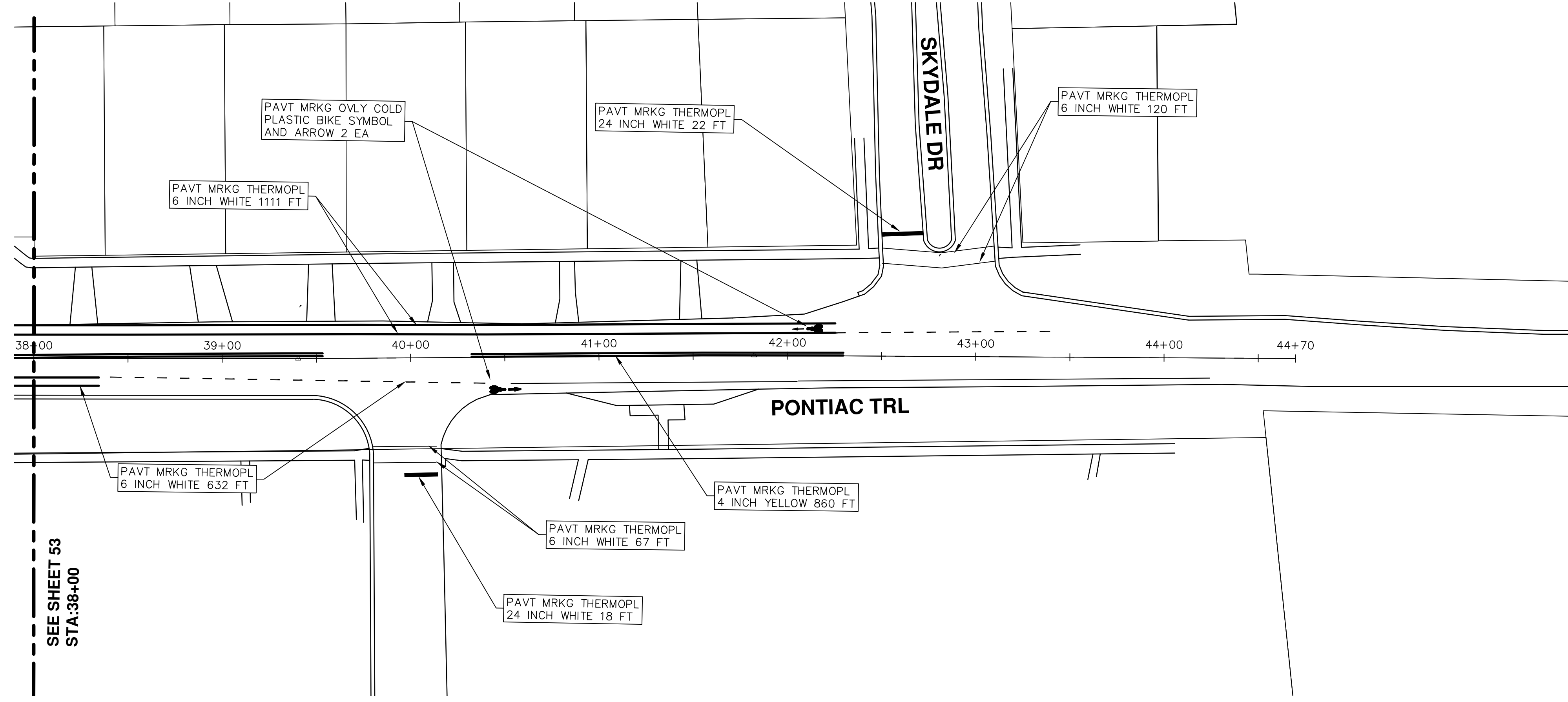

SEE SHEET 53
STA: 38+00



REV.	DESCRIPTION	DATE	DRAWN	CHECKED
02	ADDENDUM #3	3-15-2016	DAD	DAD
01	ADDENDUM #1	3-7-2016	DAD	DAD
00	BID SET	2-22-2016	SS AH JK	DAD

CITY OF ANN ARBOR
PUBLIC SERVICES
301 EAST HURON STREET
ANN ARBOR MI 48106-8647
www.a2gov.org

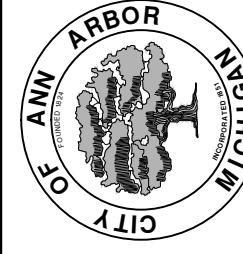

PROJECT MANAGEMENT - PUBLIC SERVICES - CITY OF ANN ARBOR
STREET RESURFACING - 2016
PONTIAC TRAIL
PAVEMENT MARKINGS

SCALE PLAN: 1" = 40'
DRAWING No.
2016004-54



CITY OF ANN ARBOR PROJECT MANAGEMENT STREET RESURFACING - 2016 LOCATION: HURON RIVER DRIVE

ITB No. 4422 FILE No. 2016004



S:\Project Management\Drafting\autocad\2016004\Plan Production\2016004-HURON RIVER DR.dwg Dwg Created: 24-Nov-15 - a2 standard bw.stb - Plot Date: 15-Mar-16

QUANTITIES			
Item Code	Item Description	Units	Quantity
2057021	Subgrade Undercutting, Type IIA	Cyd	2,535.000
4037050	Dr Structure Cover, Type B, Modified	Ea	1.000
4037050	Dr Structure, Adj, Case 1, Modified	Ea	1.000
4037050	Dr Structure, Temp Lowering, Modified	Ea	1.000
5010003	Cold Milling HMA Surface	Ton	1,355.000
5010005	HMA Surface, Rem	Syd	253.000
5010025	Hand Patching	Ton	21.000
5010057	HMA, 5E3	Ton	1,338.000
5010061	HMA, Approach	Ton	17.000
5017050	HMA Surface, Around Structure Cover, Rem	Ea	5.000
8110154	Pavt Mrkg, Sprayable Thermopl, 4 inch, Yellow	Ft	12,354.000
8110155	Pavt Mrkg, Sprayable Thermopl, 6 inch, White	Ft	9,751.000
8110218	Pavt Mrkg, Thermopl, 24 inch, Stop Bar	Ft	14.000
8120012	Barricade, Type III, High Intensity, Double Sided, Lighted, Fum	Ea	4.000
8120013	Barricade, Type III, High Intensity, Double Sided, Lighted, Oper	Ea	4.000
8120140	Lighted Arrow, Type C, Furn	Ea	1.000
8120141	Lighted Arrow, Type C, Oper	Ea	1.000
8120260	Plastic Drum, High Intensity, Lighted, Fum	Ea	100.000
8120261	Plastic Drum, High Intensity, Lighted, Oper	Ea	100.000
8120330	Sign, Portable, Changeable Message, Fum	Ea	3.000
8120331	Sign, Portable, Changeable Message, Oper	Ea	3.000
8120350	Sign, Type B, Temp, Prismatic, Fum	Sft	471.000
8120351	Sign, Type B, Temp, Prismatic, Oper	Sft	471.000
8127050	No Parking Sign	Ea	88.000

CONSTRUCTION KEY	
KEY	ASSOCIATED PAY ITEM(S)
AA	• Dr Structure, Adj, Case 1, Modified • Dr Structure, Adj, Case 2, Modified • Dr Structure, Temp Lowering, Modified
AB	• Dr Structure, Temp Lowering, Modified • Gate Box, Adj, Case 1 • Gate Box, Adj, Case 2 • Monument Box Adjust
ADST	• Dr Structure, Adj, Add Depth, Modified
AK	• Dr Structure, Adj, Case 1, Modified
C4	• Sidewalk, Sidewalk Ramp, and Driveway Approach, Any Thickness, Rem • Grading, Sidewalk • Sidewalk, Conc, 4 inch, Modified
C4HE	• Sidewalk, Sidewalk Ramp, and Driveway Approach, Any Thickness, Rem • Grading, Sidewalk • Cement • Sidewalk, Conc, 4 inch, Modified
C6	• Sidewalk, Sidewalk Ramp, and Driveway Approach, Any Thickness, Rem • Grading, Sidewalk • Grading, Sidewalk Ramp • Detectable Warning Surface, Modified • Sidewalk Ramp, Conc, 6 inch, Modified • Sidewalk, Conc, 6 inch, Modified
C8	• Grading, Driveway Approach • Driveway, Nonreinf Conc, 8 inch, Modified • Sidewalk, Sidewalk Ramp, and Driveway Approach, Any Thickness, Rem • Grading, Driveway Approach • Grading, Sidewalk • Grading, Sidewalk Ramp • Cement • Driveway, Nonreinf Conc, 6 inch, Modified • Driveway, Nonreinf Conc, 8 inch, Modified • Detectable Warning Surface, Modified • Sidewalk Ramp, Conc, 6 inch, Modified • Sidewalk, Conc, 6 inch, Modified
C/G	• Curb, Gutter, and Curb and Gutter, Any Type, Rem • Curb and Gutter, Conc
C/GHE	• Curb, Gutter, and Curb and Gutter, Any Type, Rem • Cement • Driveway Opening, Conc, Det M, Modified
CP	• Grading, Sidewalk • Sidewalk, Conc, 4 inch, Modified
CR	• Sidewalk, Sidewalk Ramp, and Driveway Approach, Any Thickness, Rem • Dr Structure, Rem
DS	• Sewer, Rem, Less than 24 inch • Dr Structure, 24 inch dia • Dr Structure, Rem
DSDI	• Sewer, Rem, Less than 24 inch • Dr Structure, Double Inlet
PT	• Dr Structure, Point • Dr Structure Cover, Type B • Dr Structure Cover, Type B, Special • Dr Structure, Adj, Case 1, Modified • Dr Structure, Temp Lowering, Modified
RRK	• Dr Structure Cover, Type K • Dr Structure, Adj, Case 1, Modified
RS	• Dr Structure, Reconstruct
TYPE II	• Plastic Drum, High Intensity, Lighted, Fum • Plastic Drum, High Intensity, Lighted, Oper
TYPE III	• Barricade, Type III, High Intensity, Double Sided, Lighted, Fum • Barricade, Type III, High Intensity, Double Sided, Lighted, Oper

LEGEND	
SYMBOL	DESCRIPTION
⊙	EXISTING SANITARY SEWER MANHOLE
⊕	EXISTING STORM SEWER MANHOLE
⊗	EXISTING WATER MAIN VALVE IN WELL
+	WATER MAIN GATE VALVE IN BOX
⊕	FIRE HYDRANT
⊙	MICHCON GAS CO. VALVE BOX/WELL
Ⓢ	AMERITECH TELEPHONE VAULT
⊙	ELECTRIC MANHOLE
⊙	SOIL BORING
□	EXISTING STORM SEWER INLET
⊠	MONUMENT BOX
▬	REMOVE AND REPLACE CONC. SIDEWALK
▬	PLACE CONCRETE SIDEWALK
▬	REMOVE & REPLACE CONC. CURB & GUTTER
---	CONSTRUCTION LIMITS
---	6" WRAPPED UNDERDRAIN
▨	REMOVE CONCRETE SIDEWALK
▬	SUBGRADE UNDERCUT

CONSTRUCTION METHOD AND SEQUENCING

WORK ON THIS STREET INCLUDES, BUT IS NOT LIMITED TO, THE FOLLOWING ITEMS. COMPLETE THE WORK IN ACCORDANCE WITH THE PLANS AND SPECIFICATIONS, AND AS DIRECTED BY THE ENGINEER. PERFORM THE WORK IN THE ORDER INDICATED BELOW UNLESS OTHERWISE AUTHORIZED OR DIRECTED BY THE ENGINEER.

- IMPLEMENT MAINTENANCE OF TRAFFIC (M.O.T.) PLAN, AND INSTALL SOIL EROSION AND SEDIMENTATION CONTROL MEASURES.
- CONDUCT REMOVAL WORK RELATED TO PAVEMENT, DRAINAGE, AND CONCRETE ITEMS WITH EXCEPTION TO COLDMILLING.
- INSTALL PROPOSED DRAINAGE STRUCTURES, STORM SEWER, AND UNDERDRAIN AS REQUIRED.
- PERFORM ALL CONCRETE WORK, INCLUDING RESTORATION, AS REQUIRED.
- TEMPORARY LOWER ALL STRUCTURE COVERS LOCATED WITHIN THE EXISTING PAVEMENT AREA, INCLUDING GATE AND MONUMENT BOXES AS REQUIRED.
- REMOVE 1.5 INCHES OF EXISTING HMA SURFACE BY COLDMILLING. THIS MAY INCLUDE GRANULAR BASE MATERIAL. DEPTH TO BE DETERMINED BY THE ENGINEER. PROOF ROLL WITH FULLY LOADED TRUCK.
- PERFORM ALL JOINT AND CRACK CLEANOUT, HMA/HAND PATCHING, UNDERCUTS AND/OR BASE REPAIRS AS REQUIRED.
- GRADE, SHAPE, AND COMPACT THE EXISTING BASE MATERIAL AS REQUIRED.
- ADJUST ALL STRUCTURE COVERS, INCLUDING GATE AND MONUMENT BOXES, TO THEIR FINISH ELEVATION AS REQUIRED.
- CLEAN PAVEMENT AND PLACE 1.5 INCH TOP COURSE HMA MIX (MAJOR STREETS).
- CLEAN PAVEMENT AND PLACE HMA APPROACHES AS REQUIRED.
- CLEAN PAVEMENT AND COMPLETE ALL PAVEMENT MARKINGS.
- COMPLETE ALL MISCELLANEOUS CONSTRUCTION INCLUDING ALL CLEAN UP AND FINAL RESTORATION.
- REMOVE ALL TRAFFIC CONTROL DEVICES, AND MISS DIG FLAGS.

QUANTITIES				
Sign, Type B, Temp, Prismatic				
Quantity	Sign Code	Description	Area (sqft)	Total
27.0	D3-1	Street Name Sign	4.000	108.000
0.0	M4-8a	End Detour Sign	3.000	0.000
14.0	M4-9S	Detour Sign (w/Thru Arrow)	5.000	70.000
4.0	M4-9R	Detour Sign (w/Right Arrow)	5.000	20.000
5.0	M4-9L	Detour Sign (w/Left Arrow)	5.000	25.000
2.0	SP-1	Special Sign	20.000	40.000
0.0	R11-2	Road Closed Sign ("Road Closed")	10.000	0.000
2.0	R11-4	Road Closed Sign ("Road Closed To Thru Traffic")	12.500	25.000
4.0	W20-1	Road Work Ahead Sign	9.000	36.000
7.0	W20-2	Detour Ahead Sign	9.000	63.000
4.0	W20-3	Road Closed Ahead Sign	9.000	36.000
		TOTAL		423.000

NOTES

FOR PROTECTION OF UNDERGROUND UTILITIES AND IN CONFORMANCE WITH PUBLIC ACT 174 OF 2013, THE CONTRACTOR SHALL CALL 811 OR 1-800-482-7171 A MINIMUM OF THREE FULL WORKING DAYS, EXCLUDING SATURDAYS, SUNDAYS, AND HOLIDAYS, PRIOR TO BEGINNING EACH EXCAVATION IN AREAS WHERE PUBLIC UTILITIES HAVE NOT BEEN PREVIOUSLY LOCATED. MEMBERS WILL THUS BE ROUTINELY NOTIFIED. THIS DOES NOT RELIEVE THE CONTRACTOR OF THE RESPONSIBILITY OF NOTIFYING UTILITY OWNERS WHO MAY NOT BE A PART OF THE "MISS DIG" ALERT SYSTEM.

THE UNDERGROUND LOCATIONS SHOWN FOR NATURAL GAS, TELEPHONE, ELECTRICAL POWER, CABLE TV AND FIBER OPTIC LINES ARE APPROXIMATE. THE CITY OF ANN ARBOR ASSUMES NO RESPONSIBILITY FOR THEIR ACCURATE REPRESENTATION IN THIS DRAWING. MISS DIG MUST BE CONTACTED PRIOR TO CONSTRUCTION TO LOCATE THESE UTILITIES.

THE IMPROVEMENTS COVERED BY THESE PLANS SHALL BE PERFORMED IN ACCORDANCE WITH MICHIGAN DEPARTMENT OF TRANSPORTATION (MDOT) 2012 STANDARD SPECIFICATIONS FOR CONSTRUCTION, INCLUDING REFERENCED MDOT PUBLICATIONS, AND THE PROJECT CONTRACT DOCUMENTS.



PROJECT MANAGEMENT SERVICES UNIT
CITY OF ANN ARBOR PUBLIC SERVICES
301 EAST HURON STREET, P.O. BOX 8647
ANN ARBOR, MICHIGAN 48107-8647
734-794-6410 www.a2gov.org

PROJECT MANAGEMENT - PUBLIC SERVICES - CITY OF ANN ARBOR
STREET RESURFACING - 2016
HURON RIVER DRIVE
DRAWING No. 2016004-55

TRAFFIC CONTROL SIGN		
TAG	SIGN	NUM.
①		D3-1 M4-9S 30x24
②		D3-1 M4-9R 30x24
③		D3-1 M4-9L 30x24
⑥		D3-1 M4-8a 24x18
⑧		SPECIAL 48x60
⑩		W20-2 48x48 D3-1
⑫		SPECIAL 48x60

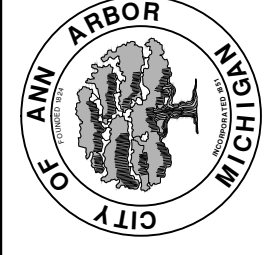

CITY OF ANN ARBOR
 PUBLIC SERVICES
 301 EAST HURON STREET
 P.O. BOX 8647
 ANN ARBOR MI 4810-8647
 www.a2gov.org

REV.	DESCRIPTION	DATE	DRAWN	CHECKED
02	ADDENDUM #3	3-15-2016	DAD	DAD
01	ADDENDUM #1	3-7-2016	DAD	DAD
00	BID SET	2-22-2016	SS AH JK	DAD



S:\Project Management\Drafting\autocad\2016004\Plan Production\2016004-HURON RIVER DR.dwg Dwg Created: 24-Nov-15 - _a2_standard.bw.stb - Plot Date: 15-Mar-16

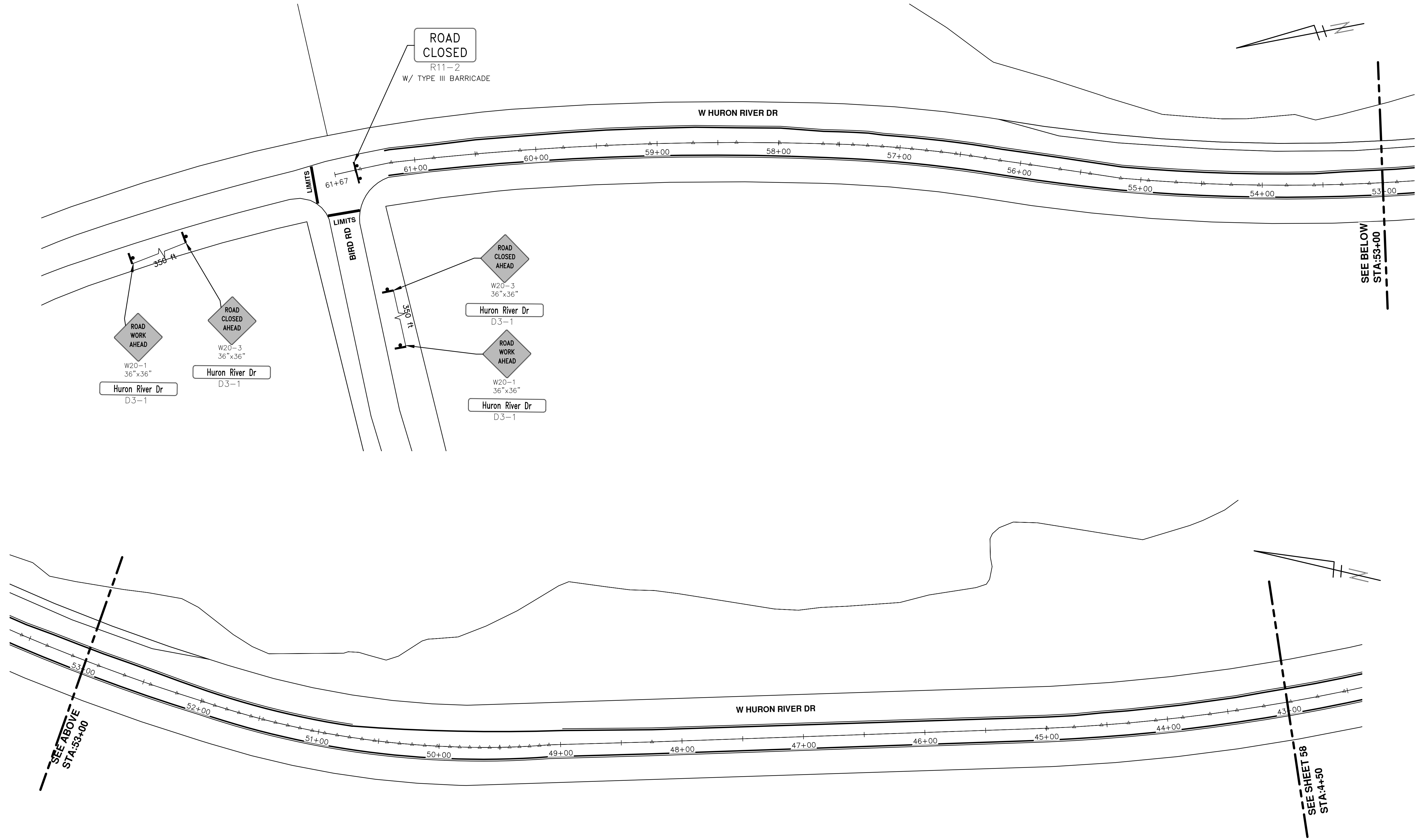

PROJECT MANAGEMENT - PUBLIC SERVICES - CITY OF ANN ARBOR
STREET RESURFACING - 2016
 HURON RIVER DRIVE
 TRAFFIC CONTROL

SCALE PLAN: 1" = 40'
 DRAWING No. 2016004-57

811
 Know what's below.
 Call Before you dig.

CITY OF ANN ARBOR
 PUBLIC SERVICES
 301 EAST HURON STREET
 ANN ARBOR, MI 48106-8647
 www.a2gov.org

REV.	DESCRIPTION	DATE	DRAWN	CHECKED
02	ADDENDUM #3	3-15-2016	DAD	DAD
01	ADDENDUM #1	3-7-2016	DAD	DAD
00	BID SET	2-22-2016	GS AH JK	DAD

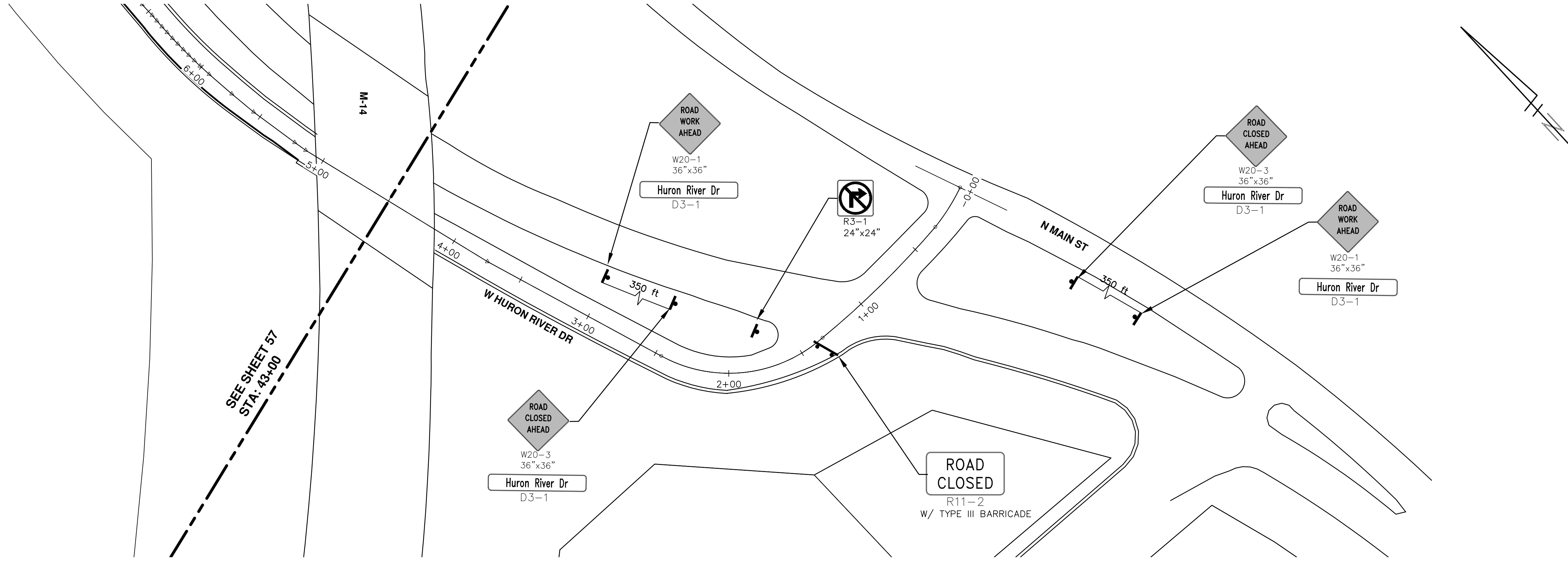

REV.	DESCRIPTION	DATE	DRAWN	CHECKED
02	ADDENDUM #3	3-15-2016	DAD	DAD
01	ADDENDUM #1	3-7-2016	DAD	DAD
00	BID SET	2-22-2016	SS AH JK	DAD

S:\Project Management\Drafting\autocad\2016004\Plan Production\2016004-HURON RIVER DR.dwg Dwg Created: 24-Nov-15 --_a2_standard.bw.stb -- Plot Date: 15-Mar-16

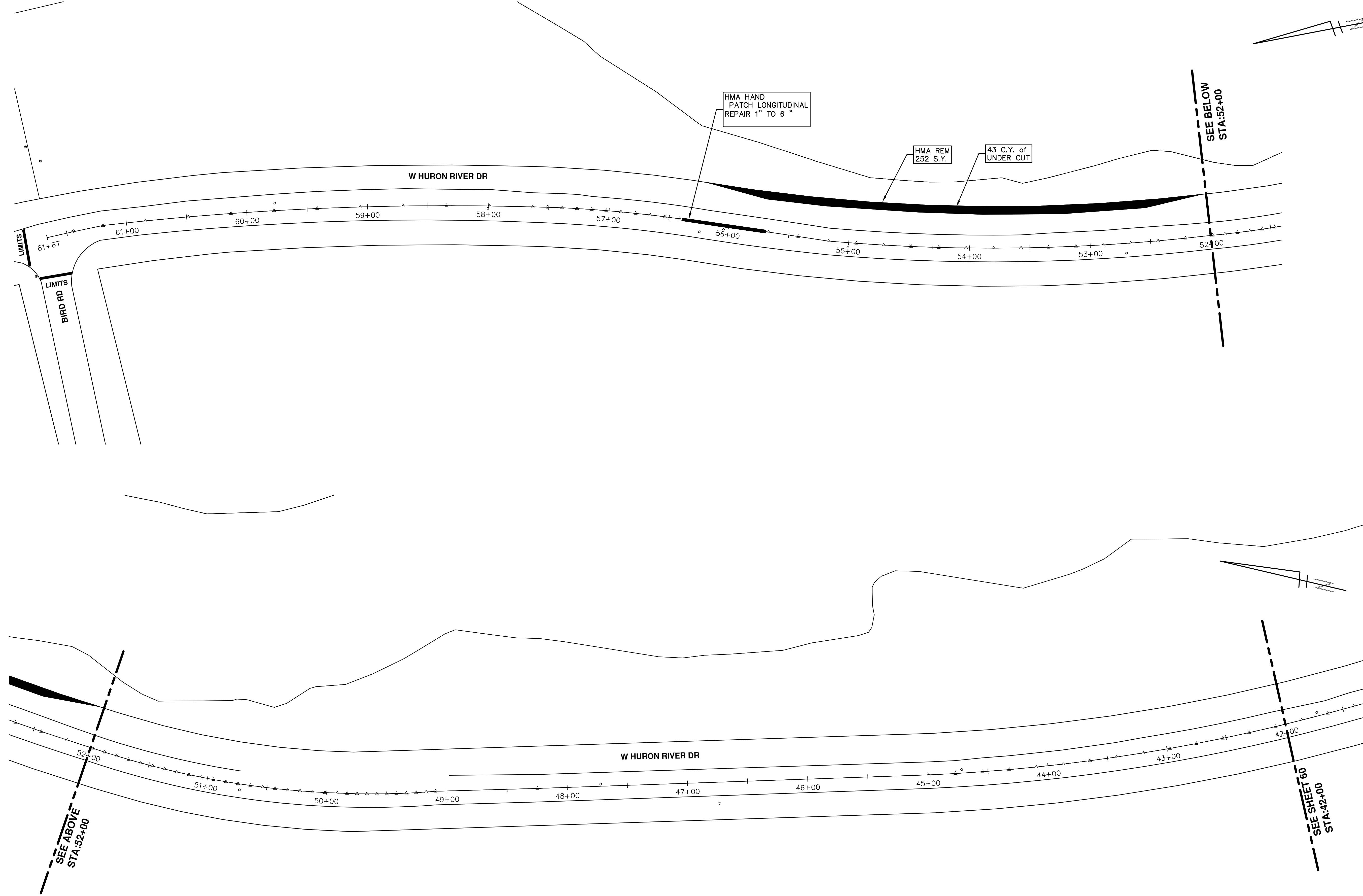

CITY OF ANN ARBOR
PUBLIC SERVICES
301 EAST HURON STREET
ANN ARBOR MI 48106-8647
www.a2gov.org

REV.	DESCRIPTION	DATE	DRAWN	CHECKED
02	ADDENDUM #3	3-15-2016	DAD	DAD
01	ADDENDUM #1	3-7-2016	DAD	DAD
00	BID SET	2-22-2016	GS AH JK	DAD

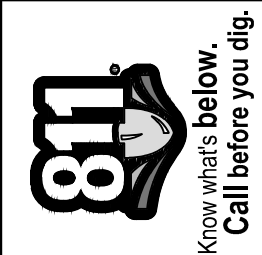

S:\Project Management\Drafting\autocad\2016004\Plan Production\2016004-HURON RIVER DR.dwg Dwg Created: 24-Nov-15 - _a2_standard bw.stb - Plot Date: 15-Mar-16

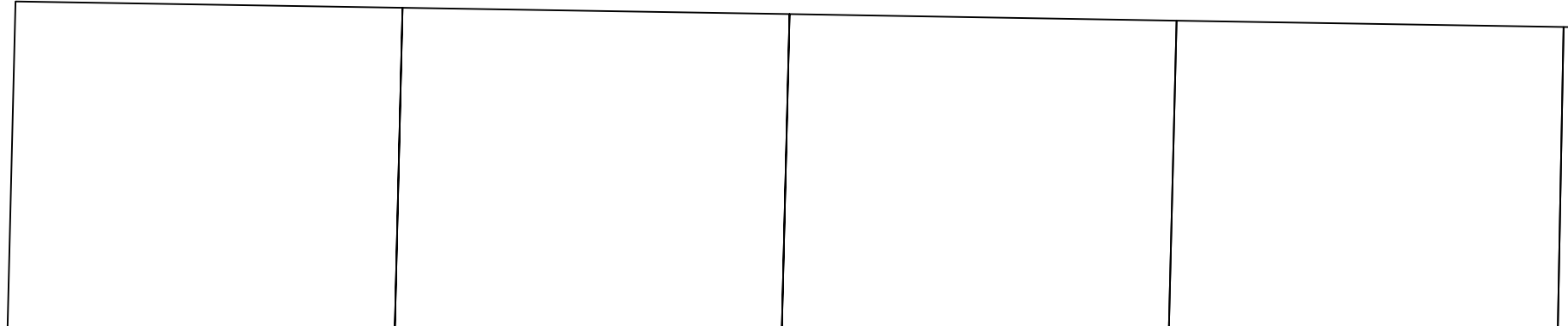
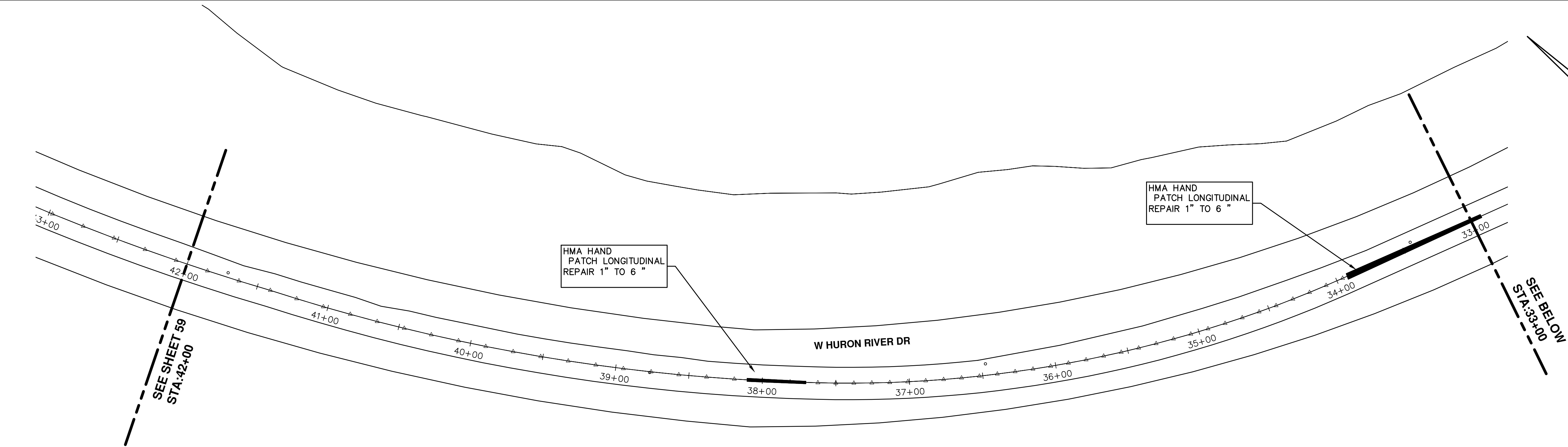
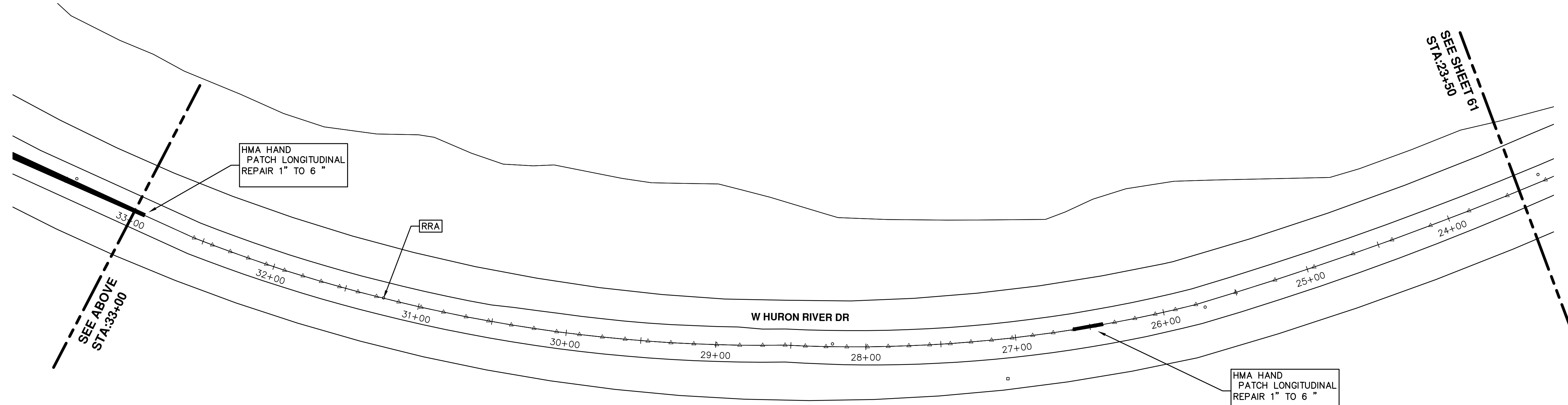

PROJECT MANAGEMENT - PUBLIC SERVICES - CITY OF ANN ARBOR
STREET RESURFACING - 2016
 HURON RIVER DRIVE
 RESURFACING

SCALE PLAN: 1" = 40'
 DRAWING No. 2016004-60

811
 Know what's below.
 Call Before you dig.

REV.	DATE	DESCRIPTION
02	3-15-2016	ADDENDUM #3
01	3-7-2016	ADDENDUM #1
00	2-22-2016	BID SET

CITY OF ANN ARBOR
 PUBLIC SERVICES
 301 EAST HURON STREET
 ANN ARBOR, MI 48106-8647
 www.a2gov.org

S:\Project Management\Drafting\autocad\2016004\Plan Production\2016004-HURON RIVER DR.dwg Dwg Created: 24-Nov-15 - _a2_standard bw.stb - Plot Date: 15-Mar-16

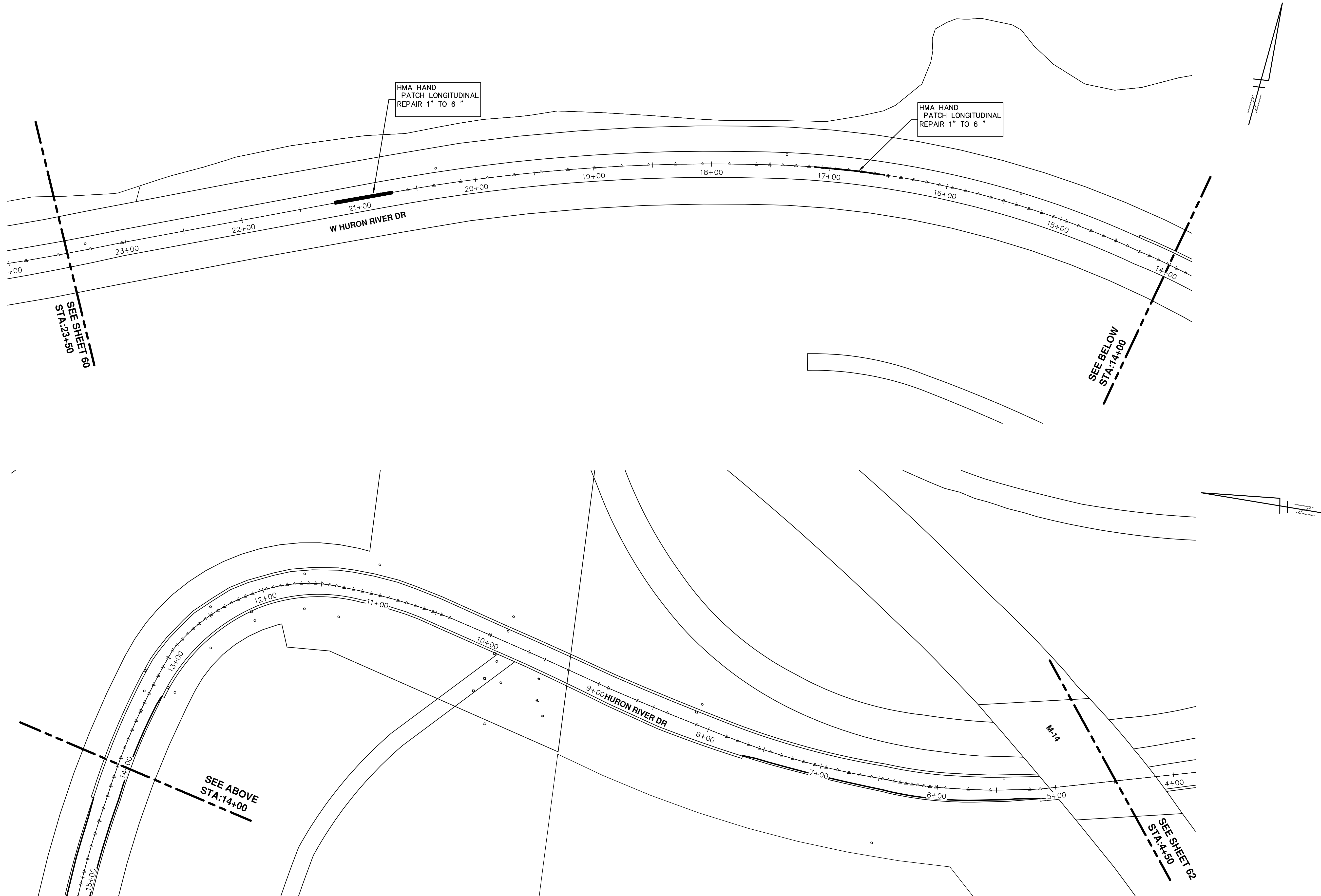

SEE SHEET 60
STA: 23+50

SEE ABOVE
STA: 14+00

SEE BELOW
STA: 14+00

SEE SHEET 62
STA: 4+50

PROJECT MANAGEMENT - PUBLIC SERVICES - CITY OF ANN ARBOR
STREET RESURFACING - 2016
 HURON RIVER DRIVE
 RESURFACING

SCALE PLAN: 1" = 40'
 DRAWING No. 2016004-61

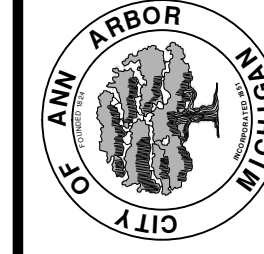

CITY OF ANN ARBOR
 PUBLIC SERVICES
 301 EAST HURON STREET
 ANN ARBOR, MI 48106-8647
 www.a2gov.org

REV.	BID SET	DATE	DESCRIPTION
02	ADDENDUM #3	3-15-2016	
01	ADDENDUM #1	3-7-2016	
00		2-22-2016	

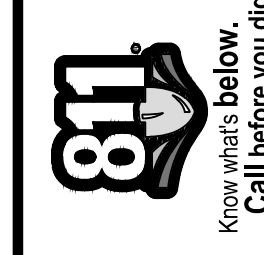

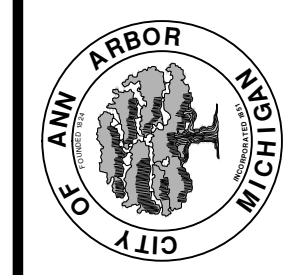
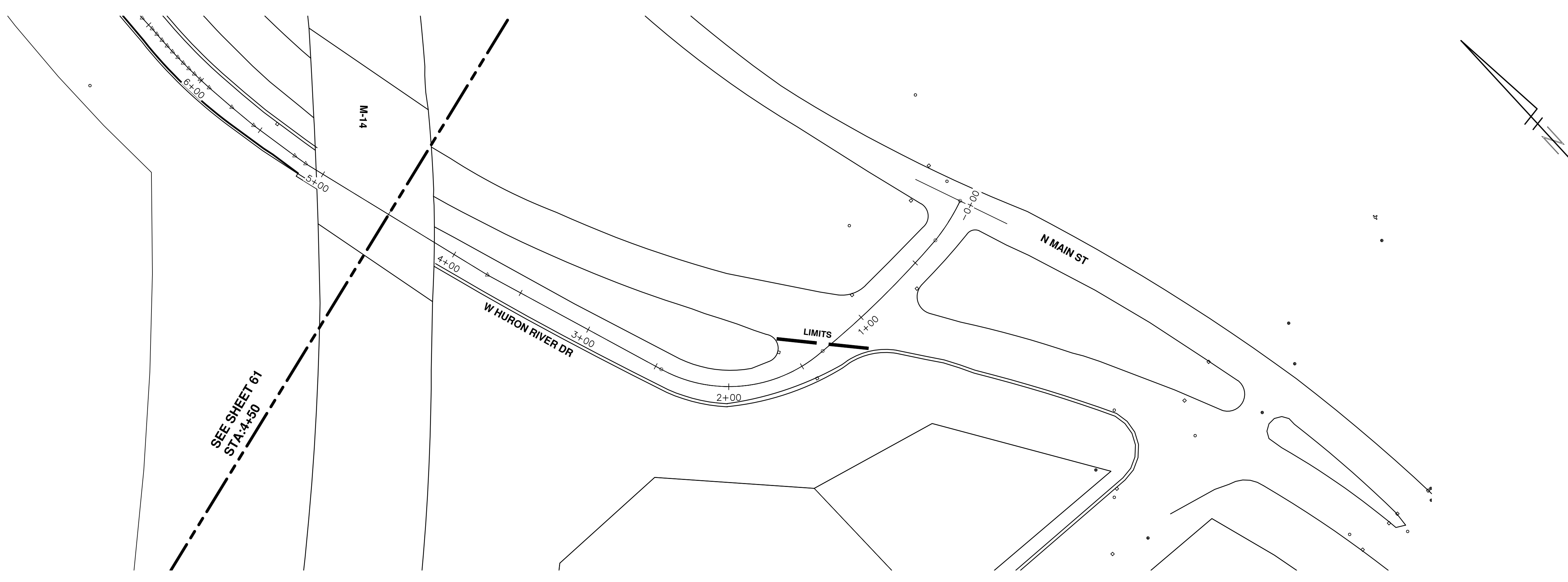



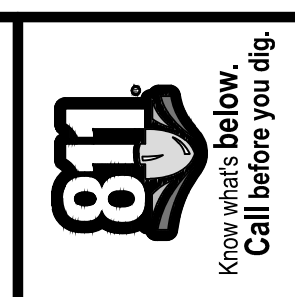

CITY OF ANN ARBOR
 PUBLIC SERVICES
 301 EAST HURON STREET
 P.O. BOX 8647
 ANN ARBOR, MI 48106-8647
 www.a2gov.org

REV.	DESCRIPTION	DATE	DRAWN	CHECKED
02	ADDENDUM #3	3-15-2016	DAD	DAD
01	ADDENDUM #1	3-7-2016	DAD	DAD
00	BID SET	2-22-2016	SS AH UK	DAD

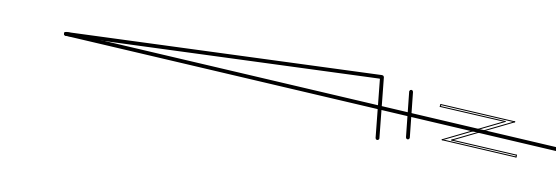
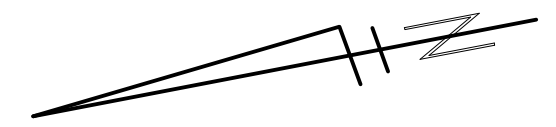
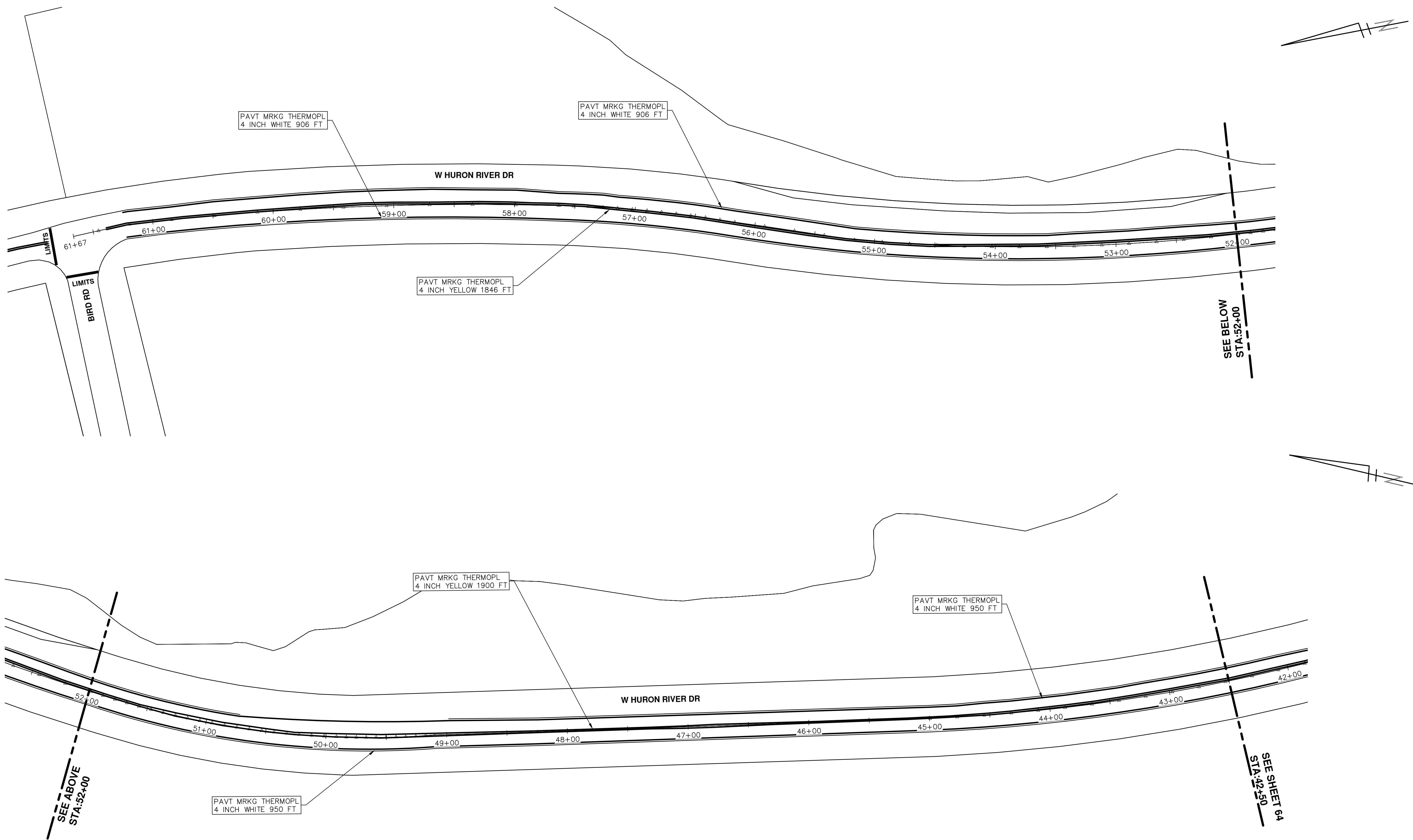

S:\Project Management\Drafting\autocad\2016004\Plan Production\2016004-HURON RIVER DR.dwg Dwg Created: 24-Nov-15 - _a2_standard.bw.stb - Plot Date: 15-Mar-16



 Know what's below. Call Before you dig.	
02 ADDENDUM #3 3-15-2016	DAD DAD
01 ADDENDUM #1 3-7-2016	DAD DAD
00 BID SET 2-22-2016	ISS AH JK DAD DATE
CITY OF ANN ARBOR PUBLIC SERVICES 301 EAST HURON STREET P.O. BOX 8647 ANN ARBOR MI 48106-8647 www.a2gov.org	DESCRIPTION DRAWN CHECKED
	
PROJECT MANAGEMENT - PUBLIC SERVICES - CITY OF ANN ARBOR STREET RESURFACING - 2016 HURON RIVER DRIVE PAVEMENT MARKINGS	
SCALE PLAN: 1" = 40' 	DRAWING No. 2016004-63
SHEET No. 63 OF 98	

S:\Project Management\Drafting\autocad\2016004\Plan Production\2016004-HURON RIVER DR.dwg Dwg Created: 24-Nov-15 - _a2_standard.bw.stb - Plot Date: 15-Mar-16

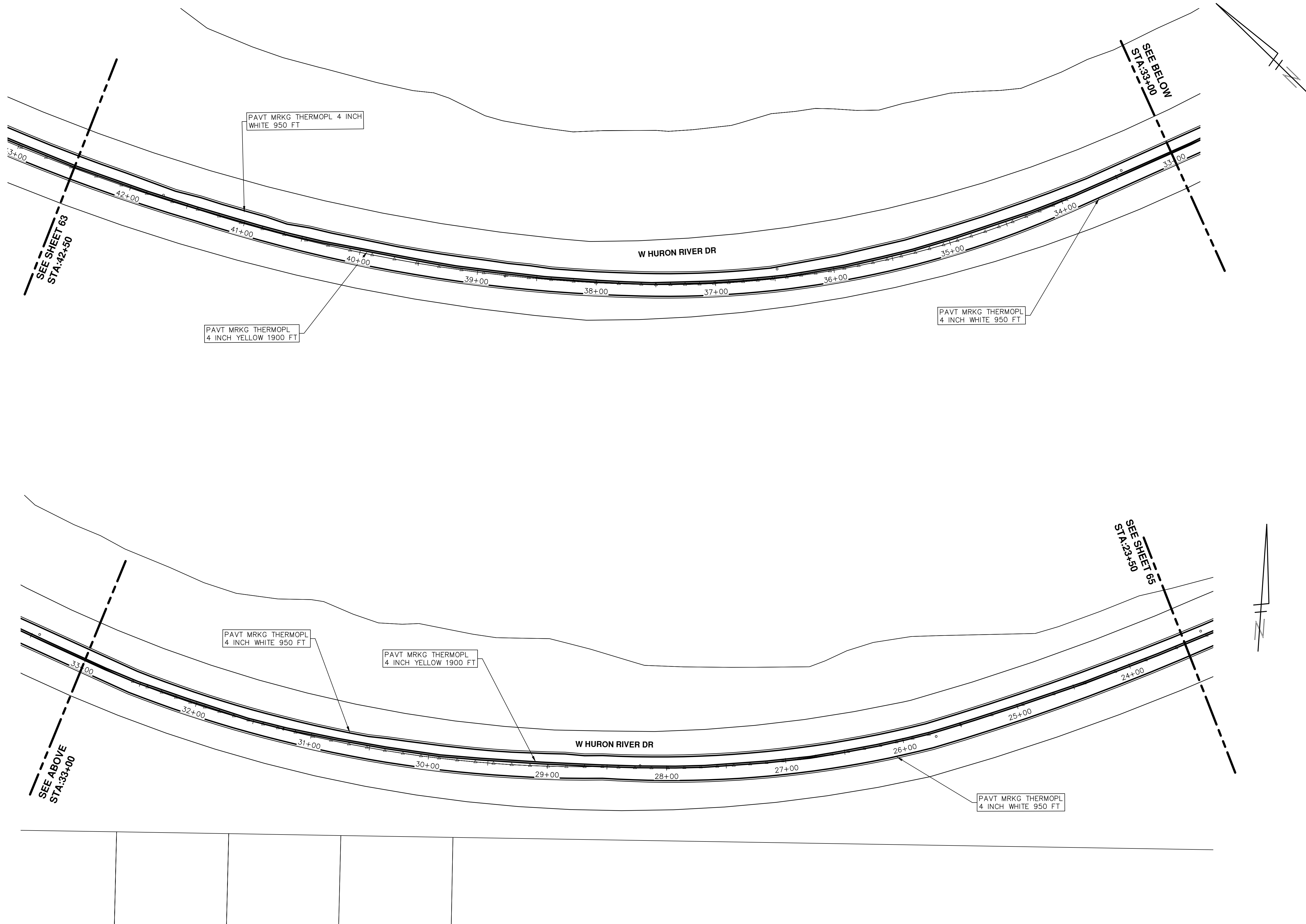

PROJECT MANAGEMENT - PUBLIC SERVICES - CITY OF ANN ARBOR
STREET RESURFACING - 2016
 HURON RIVER DRIVE
 PAVEMENT MARKINGS

SCALE PLAN: 1" = 40'

DRAWING No. 2016004-64



CITY OF ANN ARBOR
 PUBLIC SERVICES
 301 EAST HURON STREET
 ANN ARBOR, MI 48106-8647
 www.a2gov.org

REV.	DESCRIPTION	DATE	DRAWN	CHECKED
02	ADDENDUM #3	3-15-2016	DAD	DAD
01	ADDENDUM #1	3-7-2016	DAD	DAD
00	BID SET	2-22-2016	GS AH JK	DAD



Know what's below.
Call Before you dig.

S:\Project Management\Drafting\autocad\2016004\Plan Production\2016004-HURON RIVER DR.dwg Dwg Created: 24-Nov-15 - _a2_standard bw.stb - Plot Date: 15-Mar-16

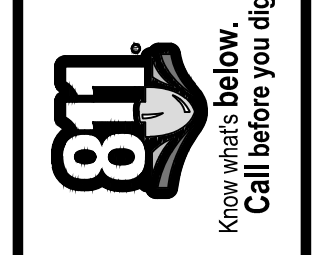
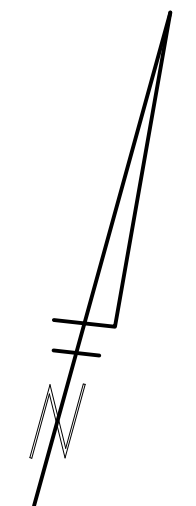
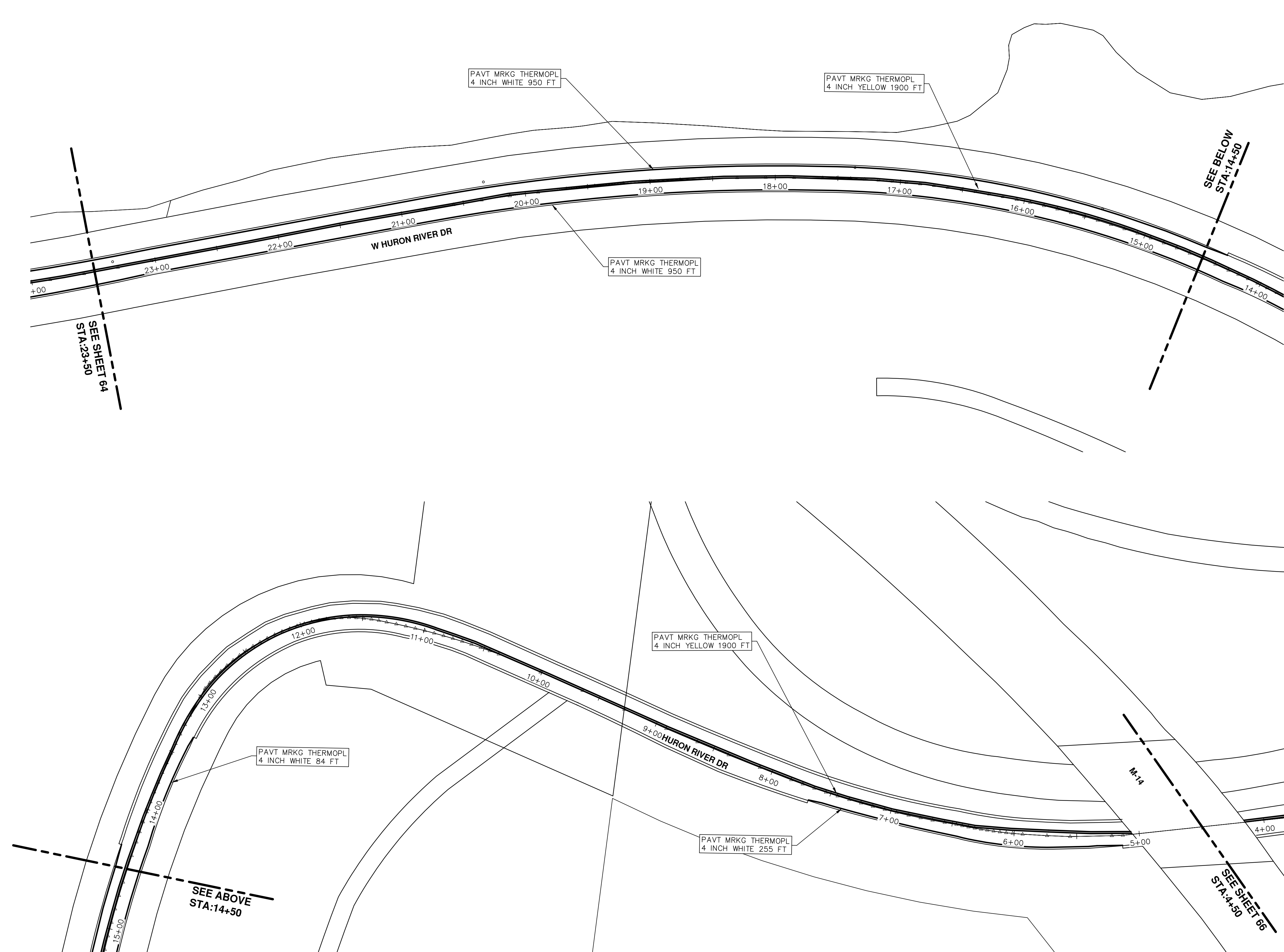

REV.	DESCRIPTION	DATE	DRAWN	CHECKED
02	ADDENDUM #3	3-15-2016	DAD	DAD
01	ADDENDUM #1	3-7-2016	DAD	DAD
00	BID SET	2-22-2016	GS AH JK	DAD

CITY OF ANN ARBOR
 PUBLIC SERVICES
 301 EAST HURON STREET
 ANN ARBOR, MI 48106-8647
 www.a2gov.org

PROJECT MANAGEMENT - PUBLIC SERVICES - CITY OF ANN ARBOR
STREET RESURFACING - 2016
 HURON RIVER DRIVE
 PAVEMENT MARKINGS

SCALE PLAN: 1" = 40'
 DRAWING No. 2016004-65

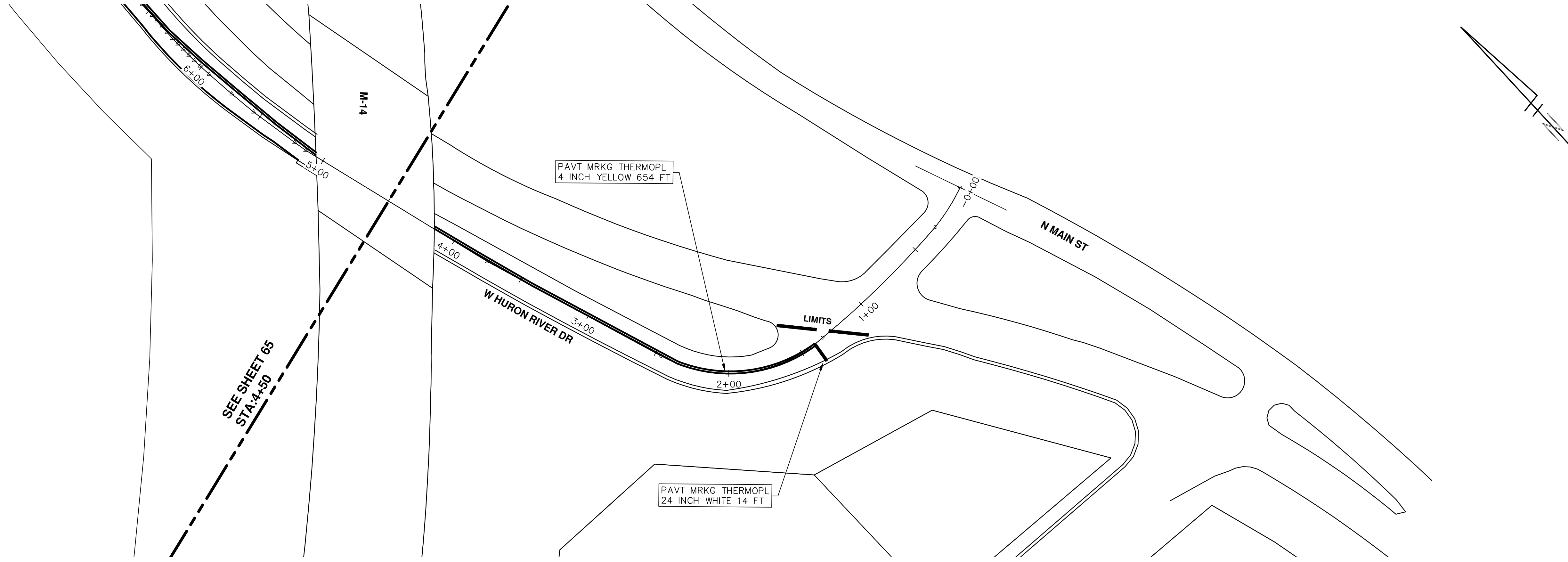

PROJECT MANAGEMENT - PUBLIC SERVICES - CITY OF ANN ARBOR
STREET RESURFACING - 2016
 HURON RIVER DRIVE
 PAVEMENT MARKINGS

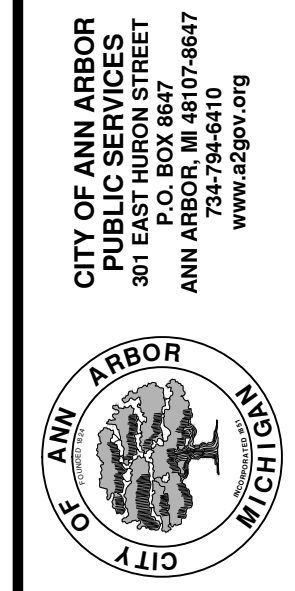

REV.	DESCRIPTION	DATE	DRAWN	CHECKED
02	ADDENDUM #3	3-15-2016	DAD	DAD
01	ADDENDUM #1	3-7-2016	DAD	DAD
00	BID SET	2-22-2016	SS AH JK	DAD





CITY OF ANN ARBOR PROJECT MANAGEMENT STREET RESURFACING - 2016 LOCATION: MAIDEN LANE

ITB No. 4422 FILE No. 2016004

CONSTRUCTION METHOD AND SEQUENCING

WORK ON THIS STREET INCLUDES, BUT IS NOT LIMITED TO, THE FOLLOWING ITEMS. COMPLETE THE WORK IN ACCORDANCE WITH THE PLANS AND SPECIFICATIONS, AS DIRECTED BY THE ENGINEER, AND UTILIZING PART WITH TWO (2) PHASE CONSTRUCTION. PERFORM THE WORK IN THE ORDER INDICATED BELOW UNLESS OTHERWISE AUTHORIZED OR DIRECTED BY THE ENGINEER. COMPLETE ITEMS 7 THRU 15 UTILIZING THE M.O.T. PLAN CURRENTLY IN PLACE, LANE CLOSURES, AND FLAG CONTROL OPERATIONS AS DIRECTED BY THE ENGINEER.

PHASE I

1. IMPLEMENT MAINTENANCE OF TRAFFIC (M.O.T.) PLAN, AND INSTALL SOIL EROSION AND SEDIMENTATION CONTROL MEASURES.
2. CONDUCT REMOVAL WORK RELATED TO PAVEMENT, DRAINAGE, AND CONCRETE ITEMS WITH EXCEPTION TO COLDMILLING.
3. INSTALL PROPOSED DRAINAGE STRUCTURES, STORM SEWER, AND UNDERDRAIN AS REQUIRED.
4. PERFORM ALL CONCRETE WORK, INCLUDING RESTORATION.
5. TEMPORARY LOWER ALL STRUCTURE COVERS LOCATED WITHIN THE EXISTING PAVEMENT AREA, INCLUDING GATE AND MONUMENT BOXES.

PHASE II

6. REPEAT ITEMS 1 THRU 5 IN THE ORDER SHOWN SHOWN ABOVE.
7. REMOVE 3.5 INCHES OF EXISTING HMA SURFACE BY COLDMILLING. THIS MAY INCLUDE GRANULAR BASE MATERIAL. DEPTH TO BE DETERMINED BY THE ENGINEER. PROOF ROLL WITH FULLY LOADED TRUCK.
8. PERFORM ALL JOINT AND CRACK CLEANOUT. HMA/HAND PATCHING, UNDERCUTS AND/OR BASE REPAIRS AS REQUIRED.
9. GRADE, SHAPE, AND COMPACT THE EXISTING BASE MATERIAL AS REQUIRED.
10. ADJUST ALL STRUCTURE COVERS, INCLUDING GATE AND MONUMENT BOXES, TO THEIR FINISH ELEVATION.
11. CLEAN PAVEMENT AND PLACE 2.0 INCH LEVELING COURSE HMA MIX (MAJOR STREETS).
12. CLEAN PAVEMENT AND PLACE 1.5 INCH TOP COURSE HMA MIX (MAJOR STREETS).
13. CLEAN PAVEMENT AND PLACE HMA APPROACHES AS REQUIRED.
14. CLEAN PAVEMENT AND COMPLETE ALL PAVEMENT MARKINGS.
15. COMPLETE ALL MISCELLANEOUS CONSTRUCTION INCLUDING ALL CLEAN UP AND FINAL RESTORATION.
16. REMOVE ALL TRAFFIC CONTROL DEVICES, AND MISS DIG FLAGS.

NOTES

FOR PROTECTION OF UNDERGROUND UTILITIES AND IN CONFORMANCE WITH PUBLIC ACT 174 OF 2013, THE CONTRACTOR SHALL CALL 811 OR 1-800-482-7171 A MINIMUM OF THREE FULL WORKING DAYS, EXCLUDING SATURDAYS, SUNDAYS, AND HOLIDAYS, PRIOR TO BEGINNING EACH EXCAVATION IN AREAS WHERE PUBLIC UTILITIES HAVE NOT BEEN PREVIOUSLY LOCATED. MEMBERS WILL THUS BE ROUTINELY NOTIFIED. THIS DOES NOT RELIEVE THE CONTRACTOR OF THE RESPONSIBILITY OF NOTIFYING UTILITY OWNERS WHO MAY NOT BE A PART OF THE "MISS DIG" ALERT SYSTEM.

THE UNDERGROUND LOCATIONS SHOWN FOR NATURAL GAS, TELEPHONE, ELECTRICAL POWER, CABLE TV AND FIBER OPTIC LINES ARE APPROXIMATE. THE CITY OF ANN ARBOR ASSUMES NO RESPONSIBILITY FOR THEIR ACCURATE REPRESENTATION IN THIS DRAWING. MISS DIG MUST BE CONTACTED PRIOR TO CONSTRUCTION TO LOCATE THESE UTILITIES.

THE IMPROVEMENTS COVERED BY THESE PLANS SHALL BE PERFORMED IN ACCORDANCE WITH MICHIGAN DEPARTMENT OF TRANSPORTATION (MDOT) 2012 STANDARD SPECIFICATIONS FOR CONSTRUCTION, INCLUDING REFERENCED MDOT PUBLICATIONS, AND THE PROJECT CONTRACT DOCUMENTS.

QUANTITIES			
Item Code	Item Description	Units	Quantity
2047001	_Curb, Gutter, and Curb and Gutter, Any Type, Rem	Ft	366.000
2047011	_Sidewalk, Sidewalk Ramp, and Driveway Approach, Any Thickness, Rem	Syd	1,905.000
2050023	Granular Material, CI II	Cyd	10.000
2057011	_Grading, Sidewalk	Syd	113.000
2057011	_Grading, Sidewalk Ramp	Syd	89.000
2057021	_Subgrade Undercutting, Type IIA	Cyd	32.000
2087050	_Erosion Control, Inlet Filter	Ea	6.000
3020001	Aggregate Base	Ton	10.000
4037050	_Dr Structure Cover, Type B, Modified	Ea	2.000
4037050	_Dr Structure, Adj, Case 1, Modified	Ea	9.000
4037050	_Dr Structure, Temp Lowering, Modified	Ea	8.000
5010003	Cold Milling HMA Surface	Ton	291.000
5010005	HMA Surface, Rem	Syd	32.000
5010051	HMA, 4E3	Ton	107.000
5010057	HMA, 5E3	Ton	80.000
5010061	HMA, Approach	Ton	105.000
6027021	Flowable Fill	Cyd	13.556
8027001	_Curb and Gutter, Conc	Ft	366.000
8037001	_Detectable Warning Surface, Modified	Ft	40.000
8037010	_Sidewalk Ramp, Conc, 6 inch, Modified	Sft	801.000
8037010	_Sidewalk, Conc, 4 inch, Modified	Sft	1,015.000
8110154	Pav Mrkg, Sprayable Thermopl, 4 inch, Yellow	Ft	1,293.000
8110197	Pav Mrkg, Thermopl, 6 inch, Crosswalk	Ft	260.000
8110218	Pav Mrkg, Thermopl, 24 inch, Stop Bar	Ft	54.000
8117001	Pav Mrkg, Thermopl, 24 inch, Crosswalk	Ft	216.000
8117050	Pav Mrkg, Thermopl, Lt Turn Arrow Sym	Ea	1.000
8117050	Pav Mrkg, Thermopl, Rt Turn Arrow Sym	Ea	1.000
8120012	Barricade, Type III, High Intensity, Double Sided, Lighted, Furn	Ea	4.000
8120013	Barricade, Type III, High Intensity, Double Sided, Lighted, Oper	Ea	4.000
8120140	Lighted Arrow, Type C, Furn	Ea	1.000
8120141	Lighted Arrow, Type C, Oper	Ea	1.000
8120260	Plastic Drum, High Intensity, Lighted, Furn	Ea	75.000
8120261	Plastic Drum, High Intensity, Lighted, Oper	Ea	75.000
8120330	Sign, Portable, Changeable Message, Furn	Ea	2.000
8120331	Sign, Portable, Changeable Message, Oper	Ea	2.000
8120350	Sign, Type B, Temp, Prismatic, Furn	Sft	356.250
8120351	Sign, Type B, Temp, Prismatic, Oper	Sft	356.250
8127050	_No Parking Sign	Ea	7.000
8167011	_Slope Restoration	Syd	135.000
8230431	Gate Box, Adj, Case 1	Ea	1.000

CONSTRUCTION KEY	
KEY	ASSOCIATED PAY ITEM(S)
AA	•_Dr Structure, Adj, Case 1, Modified •_Dr Structure, Adj, Case 2, Modified •_Dr Structure, Temp Lowering, Modified
AB	•_Dr Structure, Temp Lowering, Modified •_Gate Box, Adj, Case 1 •_Gate Box, Adj, Case 2 •_Monument Box Adjust
ADST	•_Dr Structure, Adj, Add Depth, Modified
AK	•_Dr Structure, Adj, Case 1, Modified
C4	•_Sidewalk, Sidewalk Ramp, and Driveway Approach, Any Thickness, Rem •_Grading, Sidewalk •_Sidewalk, Conc, 4 inch, Modified
C4HE	•_Sidewalk, Sidewalk Ramp, and Driveway Approach, Any Thickness, Rem •_Grading, Sidewalk •_Sidewalk, Conc, 4 inch, Modified
C6	•_Sidewalk, Sidewalk Ramp, and Driveway Approach, Any Thickness, Rem •_Grading, Sidewalk •_Sidewalk Ramp •_Detectable Warning Surface, Modified •_Sidewalk Ramp, Conc, 6 inch, Modified •_Sidewalk, Conc, 6 inch, Modified
C8	•_Grading, Driveway Approach •_Driveway, Nonreinf Conc, 8 inch, Modified •_Sidewalk, Sidewalk Ramp, and Driveway Approach, Any Thickness, Rem •_Grading, Driveway Approach •_Grading, Sidewalk •_Grading, Sidewalk Ramp
CHE	•_Cement •_Driveway, Nonreinf Conc, 6 inch, Modified •_Driveway, Nonreinf Conc, 8 inch, Modified •_Detectable Warning Surface, Modified •_Sidewalk Ramp, Conc, 6 inch, Modified •_Sidewalk, Conc, 6 inch, Modified
C/G	•_Curb, Gutter, and Curb and Gutter, Any Type, Rem •_Curb and Gutter, Conc
C/GHE	•_Curb, Gutter, and Curb and Gutter, Any Type, Rem •_Cement •_Driveway Opening, Conc, Det M, Modified
CP	•_Grading, Sidewalk •_Sidewalk, Conc, 4 inch, Modified
CR	•_Sidewalk, Sidewalk Ramp, and Driveway Approach, Any Thickness, Rem •_Dr Structure, Rem
DS	•_Sewer, Rem, Less than 24 inch •_Dr Structure, 24 inch dia •_Dr Structure, Rem
DSDI	•_Sewer, Rem, Less than 24 inch •_Dr Structure, Double Inlet
PT	•_Dr Structure, Point •_Dr Structure Cover, Type B •_Dr Structure Cover, Type B, Special •_Dr Structure, Adj, Case 1, Modified •_Dr Structure, Temp Lowering, Modified
RRK	•_Dr Structure Cover, Type K •_Dr Structure, Adj, Case 1, Modified
RS	•_Dr Structure, Reconstruct
TYPE I	•_Plastic Drum, High Intensity, Lighted, Furn •_Plastic Drum, High Intensity, Lighted, Oper
TYPE II	•_Barricade, Type III, High Intensity, Double Sided, Lighted, Furn •_Barricade, Type III, High Intensity, Double Sided, Lighted, Oper

LEGEND	
SYMBOL	DESCRIPTION
⊙	EXISTING SANITARY SEWER MANHOLE
⊕	EXISTING STORM SEWER MANHOLE
⊗	EXISTING WATER MAIN VALVE IN WELL
+	WATER MAIN GATE VALVE IN BOX
⊕	FIRE HYDRANT
⊙	MICHCON GAS CO. VALVE BOX/WELL
⊕	AMERITECH TELEPHONE VAULT
⊙	ELECTRIC MANHOLE
⊕	SOIL BORING
□	EXISTING STORM SEWER INLET
⊕	MONUMENT BOX
▬	REMOVE AND REPLACE CONC. SIDEWALK
▬	PLACE CONCRETE SIDEWALK
▬	REMOVE & REPLACE CONC. CURB & GUTTER
▬	CONSTRUCTION LIMITS
▬	6" WRAPPED UNDERDRAIN
▬	REMOVE CONCRETE SIDEWALK
▬	SUBGRADE UNDERCUT

QUANTITIES				
Sign, Type B, Temp, Prismatic				
Quantity	Sign Code	Description	Area (sft)	Total
19.0	D3-1	Street Name Sign	4.000	76.000
1.0	M4-10L	Detour Arrow Sign	6.000	6.000
1.0	M4-8a	End Detour Sign	3.000	3.000
2.0	M4-9L	Detour Sign (w/Left Arrow)	5.000	10.000
2.0	M4-9R	Detour Sign (w/Right Arrow)	5.000	10.000
8.0	M4-9S	Detour Sign (w/Thru Arrow)	5.000	40.000
1.0	R11-2	Road Closed Sign ("Road Closed")	10.000	10.000
1.0	R5-1	"Do Not Enter"	6.250	6.250
1.0	R5-18cLA	Work Zone Sign ("Work Zone Begins / Traffic Fines Doubled")	17.500	17.500
1.0	R2-1	Speed Limit (25 MPH)	5.000	5.000
1.0	R2-5B	Reduce Speed Ahead (25 MPH)	5.000	5.000
3.0	R3-1	Movement Prohibition Sign ("No Right Turn Symbol")	4.000	12.000
1.0	R3-2b	Movement Prohibition Sign ("No Left Turn")	4.000	4.000
2.0	R3-2	Movement Prohibition Sign ("No Left Turn Symbol")	4.000	8.000
1.0	R3-8	Advance Intersection Lane Control Sign (Left Turn On;y or Right Turn Only)	7.500	7.500
1.0	R6-1 L	One Way (Left) Sign	3.000	3.000
1.0	R6-1R	One Way (Right) Sign	3.000	3.000
2.0	SP-1	Special Sign	20.000	40.000
6.0	W20-1	Road Work Ahead Sign	9.000	54.000
1.0	W20-2	Detour Ahead Sign	9.000	9.000
3.0	W20-3	Road Closed Ahead Sign	9.000	27.000
		TOTAL		356.250



PROJECT MANAGEMENT SERVICES UNIT
CITY OF ANN ARBOR PUBLIC SERVICES
301 EAST HURON STREET, P.O. BOX 8647
ANN ARBOR, MICHIGAN 48107-8647
734-794-6410 www.a2gov.org



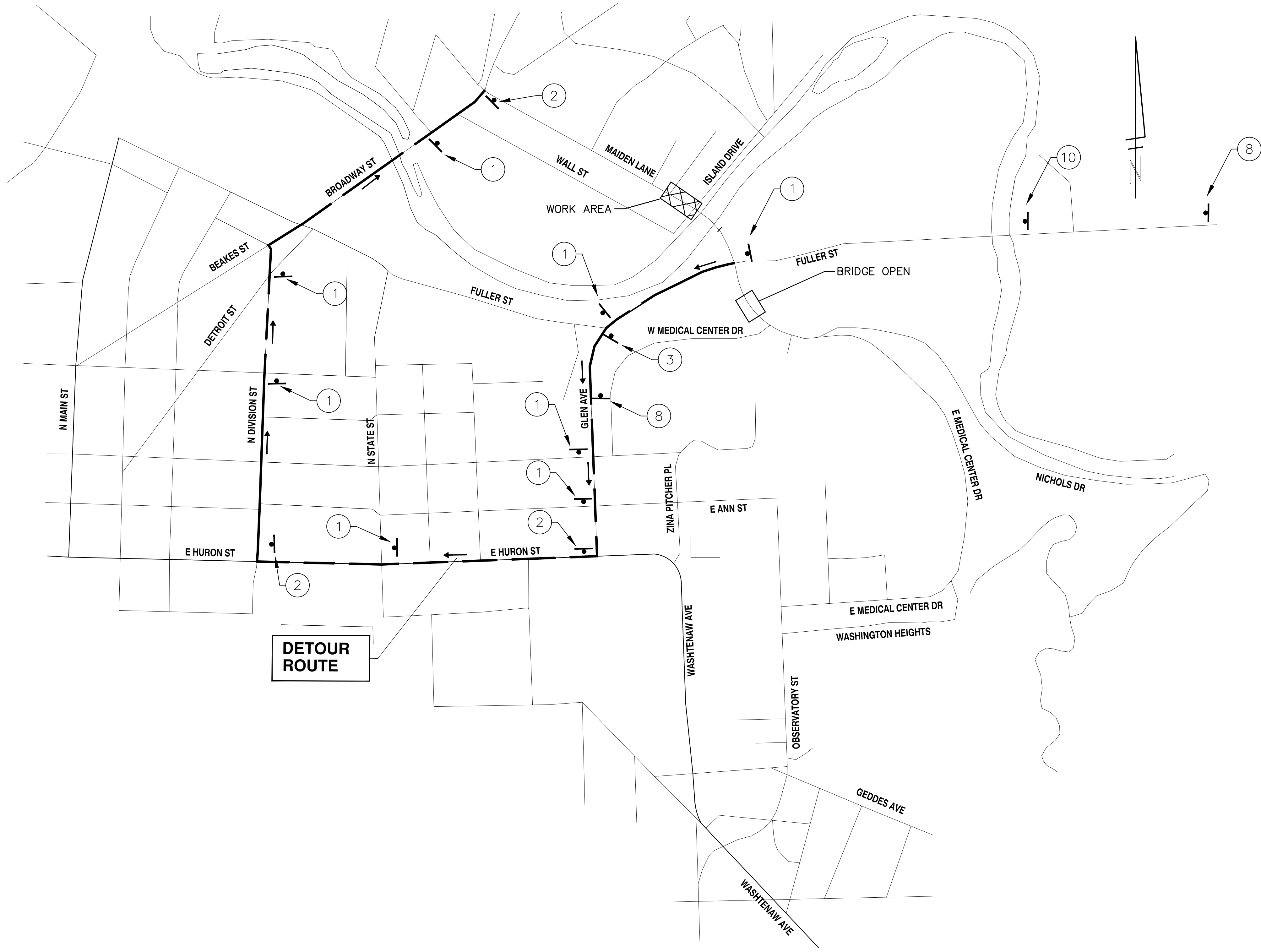

TRAFFIC CONTROL SIGN		
TAG	SIGN	NUM.
①		D3-1 M4-9S 30x24
②		D3-1 M4-9R 30x24
③		D3-1 M4-9L 30x24
⑥		D3-1 M4-8a 24X18
⑧		SPECIAL 48x60
⑩		W20-2 36"x36"

S:\Project Management\Drafting\autocad\2016004\Plan Production\2015021MTRF.dwg Dwg Created: 8-Mar-16 - _a2 standard bw.stb - Plot Date: 15-Mar-16

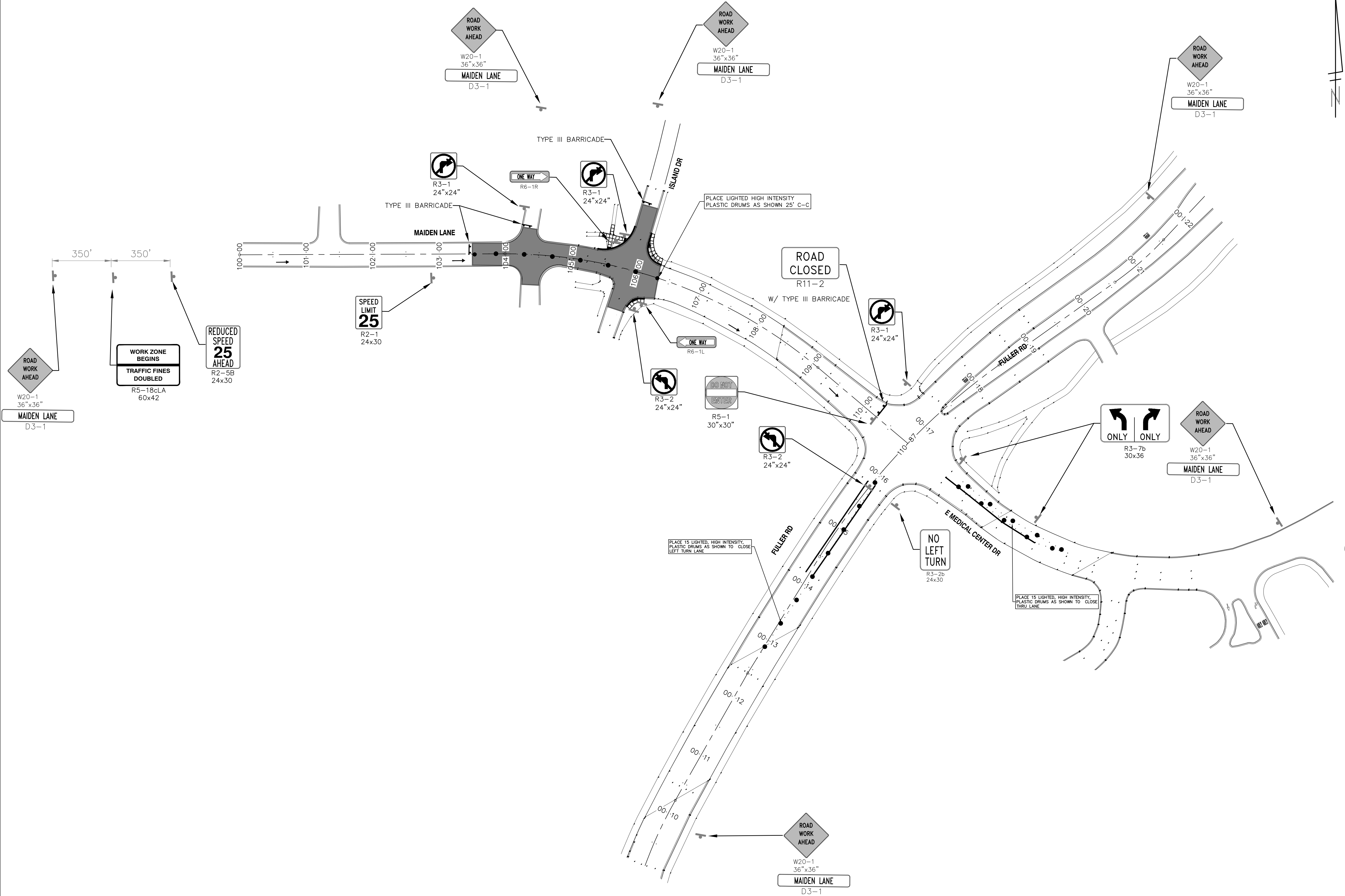

REV.	DATE	DESCRIPTION
00	3-15-2016	DRAWN
		CHECKED

CITY OF ANN ARBOR
PUBLIC SERVICES
301 EAST HURON STREET
ANN ARBOR MI 48106-8647
www.a2gov.org

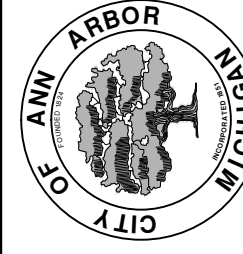

PROJECT MANAGEMENT - PUBLIC SERVICES - CITY OF ANN ARBOR
STREET RESURFACING - 2016
MAIDEN LANE
TRAFFIC CONTROL

SCALE PLAN: Custom
DRAWING No. 2016004-69

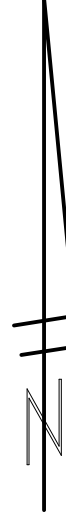
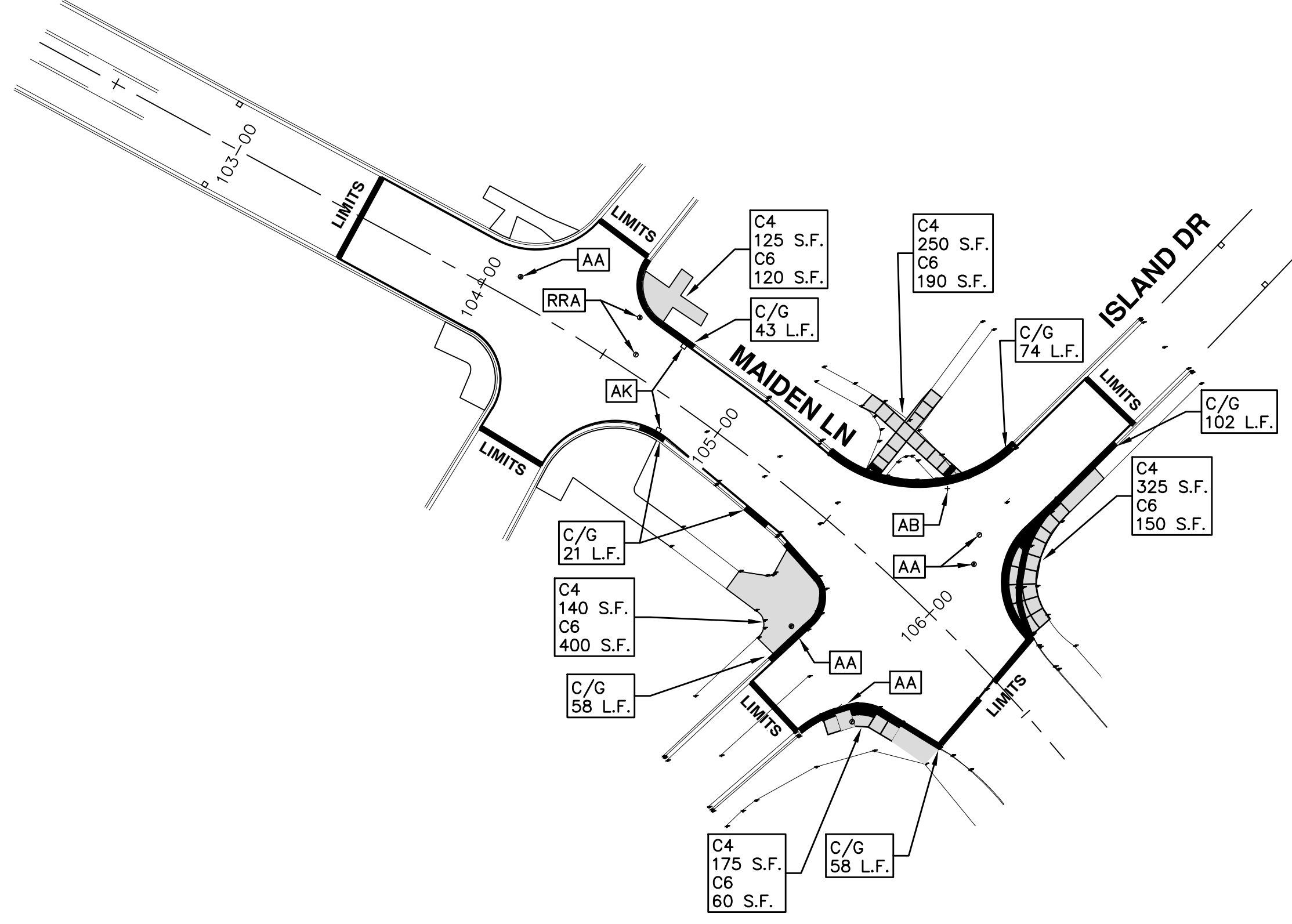

PROJECT MANAGEMENT - PUBLIC SERVICES - CITY OF ANN ARBOR
STREET RESURFACING - 2016
 MAIDEN LANE
 RESURFACING

SCALE PLAN: 1" = 40'
 DRAWING No. 2016004-70

SHEET No. 70 OF 98

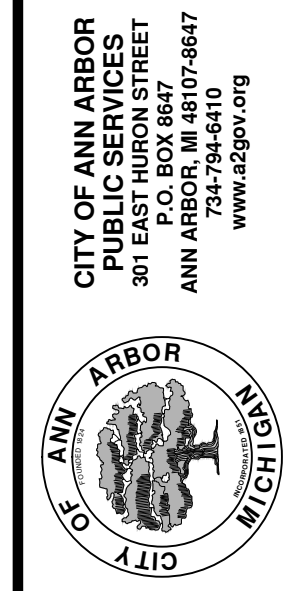

REV.	DESCRIPTION	DATE	DRAWN	CHECKED
02	ADDENDUM #3	3-15-2016	DAD	DAD



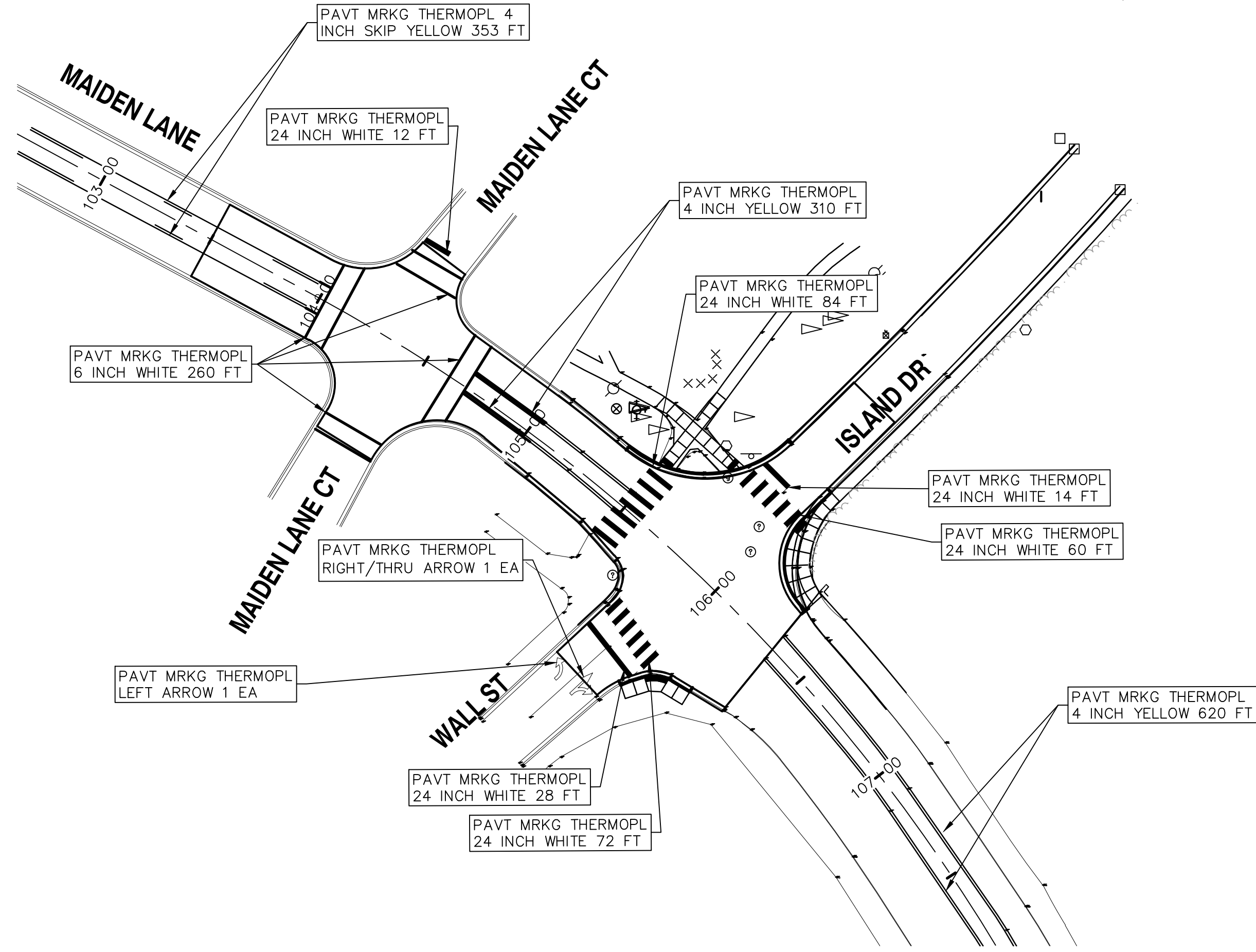

PROJECT MANAGEMENT - PUBLIC SERVICES - CITY OF ANN ARBOR
 STREET RESURFACING - 2016
 MAIDEN LANE
 PAVEMENT MARKINGS

SCALE PLAN: 1" = 40'
 PROFILE: 1" = 4'
 DRAWING No.
 2016004-71

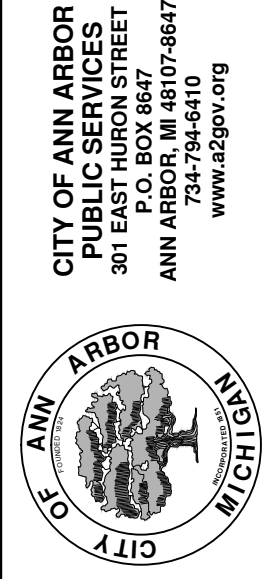

02	ADDENDUM #3	3-15-2016	DAD	DAD
REV.	DESCRIPTION	DATE	DRAWN	CHECKED





CITY OF ANN ARBOR PROJECT MANAGEMENT STREET RESURFACING - 2016

LOCATION: PACKARD ROAD & EISENHOWER PARKWAY

ITB No. 4422 FILE No. 2016004

CONSTRUCTION METHOD AND SEQUENCING

WORK ON THIS STREET INCLUDES, BUT IS NOT LIMITED TO, THE FOLLOWING ITEMS. COMPLETE THE WORK IN ACCORDANCE WITH THE PLANS AND SPECIFICATIONS, AS DIRECTED BY THE ENGINEER, AND UTILIZING PART WIDTH TWO (2) PHASE CONSTRUCTION. PERFORM THE WORK IN THE ORDER INDICATED BELOW UNLESS OTHERWISE AUTHORIZED OR DIRECTED BY THE ENGINEER. COMPLETE ITEMS 13 THRU 14 UTILIZING THE M.O.T. PLAN CURRENTLY IN PLACE, LANE CLOSURES, AND FLAG CONTROL OPERATIONS AS DIRECTED BY THE ENGINEER.

STAGE I

- IMPLEMENT MAINTENANCE OF TRAFFIC (M.O.T.) PLAN, AND INSTALL SOIL EROSION AND SEDIMENTATION CONTROL MEASURES.
- CONDUCT REMOVAL WORK RELATED TO PAVEMENT, DRAINAGE, AND CONCRETE ITEMS WITH EXCEPTION TO COLDMILLING.
- INSTALL PROPOSED DRAINAGE STRUCTURES, STORM SEWER, AND UNDERDRAIN AS REQUIRED.
- PERFORM ALL CONCRETE WORK, INCLUDING RESTORATION.
- TEMPORARY LOWER ALL STRUCTURE COVERS LOCATED WITHIN THE EXISTING PAVEMENT AREA, INCLUDING GATE AND MONUMENT BOXES.
- REMOVE 1.5 INCHES OF EXISTING HMA SURFACE BY COLDMILLING. THIS MAY INCLUDE GRANULAR BASE MATERIAL. DEPTH TO BE DETERMINED BY THE ENGINEER. PROOF ROLL WITH FULLY LOADED TRUCK.
- PERFORM ALL JOINT AND CRACK CLEANOUT. HMA/HAND PATCHING, UNDERCUTS AND/OR BASE REPAIRS AS REQUIRED.
- GRADE, SHAPE, AND COMPACT THE EXISTING BASE MATERIAL AS REQUIRED.
- ADJUST ALL STRUCTURE COVERS, INCLUDING GATE AND MONUMENT BOXES, TO THEIR FINISH ELEVATION.
- CLEAN PAVEMENT AND PLACE 1.5 INCH TOP COURSE HMA MIX (MAJOR STREETS) OVER ENTIRE STREET.
- CLEAN PAVEMENT AND PLACE HMA APPROACHES AS REQUIRED.

STAGE II

- REPEAT ITEMS 1 THRU 11 IN THE ORDER SHOWN ABOVE.
- CLEAN PAVEMENT AND COMPLETE ALL PAVEMENT MARKINGS.
- COMPLETE ALL MISCELLANEOUS CONSTRUCTION INCLUDING ALL CLEAN UP AND FINAL RESTORATION.
- REMOVE ALL TRAFFIC CONTROL DEVICES, AND MISS DIG FLAGS.

NOTES

FOR PROTECTION OF UNDERGROUND UTILITIES AND IN CONFORMANCE WITH PUBLIC ACT 174 OF 2013, THE CONTRACTOR SHALL CALL 811 OR 1-800-482-7171 A MINIMUM OF THREE FULL WORKING DAYS, EXCLUDING SATURDAYS, SUNDAYS, AND HOLIDAYS, PRIOR TO BEGINNING EACH EXCAVATION IN AREAS WHERE PUBLIC UTILITIES HAVE NOT BEEN PREVIOUSLY LOCATED. MEMBERS WILL THUS BE ROUTINELY NOTIFIED. THIS DOES NOT RELIEVE THE CONTRACTOR OF THE RESPONSIBILITY OF NOTIFYING UTILITY OWNERS WHO MAY NOT BE A PART OF THE "MISS DIG" ALERT SYSTEM.

THE UNDERGROUND LOCATIONS SHOWN FOR NATURAL GAS, TELEPHONE, ELECTRICAL POWER, CABLE TV AND FIBER OPTIC LINES ARE APPROXIMATE. THE CITY OF ANN ARBOR ASSUMES NO RESPONSIBILITY FOR THEIR ACCURATE REPRESENTATION IN THIS DRAWING. MISS DIG MUST BE CONTACTED PRIOR TO CONSTRUCTION TO LOCATE THESE UTILITIES.

THE IMPROVEMENTS COVERED BY THESE PLANS SHALL BE PERFORMED IN ACCORDANCE WITH MICHIGAN DEPARTMENT OF TRANSPORTATION (MDOT) 2012 STANDARD SPECIFICATIONS FOR CONSTRUCTION, INCLUDING REFERENCED MDOT PUBLICATIONS, AND THE PROJECT CONTRACT DOCUMENTS.

QUANTITIES			
Item Code	Item Description	Units	Quantity
2030011	Dr Structure, Rem	Ea	7.000
2030015	Sewer, Rem, Less than 24 inch	Ft	70.000
2047001	Curb, Gutter, and Curb and Gutter, Any Type, Rem	Ft	1,300.000
2047011	Sidewalk, Sidewalk Ramp, and Driveway Approach, Any Thickness, Rem	Syd	69.000
2057011	Grading, Driveway Approach	Syd	48.000
2057011	Grading, Sidewalk	Syd	12.000
2057011	Grading, Sidewalk Ramp	Syd	9.000
2057011	Machine Grading, Special	Syd	147.000
2057021	Subgrade Undercutting, Type IIA	Cyd	212.000
2087050	Erosion Control, Inlet Filter	Ea	24.000
4020987	Sewer, CI IV, 12 inch, Tr Det B	Ft	70.000
4030200	Dr Structure, 24 inch dia	Ea	6.000
4037050	Dr Structure Cover, Type B, Modified	Ea	7.000
4037050	Dr Structure Cover, Type K, Modified	Ea	11.000
4037050	Dr Structure, Adj, Case 1, Modified	Ea	9.000
4037050	Dr Structure, Double Inlet	Ea	1.000
4037050	Dr Structure, Point	Ea	1.000
4037050	Dr Structure, Temp Lowering, Modified	Ea	9.000
5010003	Cold Milling HMA Surface	Ton	1,078.000
5010005	HMA Surface, Rem	Syd	414.000
5010057	HMA, 5E3	Ton	1,078.000
6027021	Flowable Fill	Cyd	48.148
6030005	Cement	Ton	3.000
8017011	Driveway, Nonreinf Conc, 8 inch, Modified	Syd	48.000
8027001	Curb and Gutter, Conc	Ft	1,188.000
8027001	Driveway Opening, Conc, Det M, Modified	Ft	132.000
8037001	Detectable Warning Surface, Modified	Ft	10.000
8037010	Sidewalk Ramp, Conc, 6 inch, Modified	Sft	80.000
8037010	Sidewalk, Conc, 4 inch, Modified	Sft	60.000
8037010	Sidewalk, Conc, 6 inch, Modified	Sft	47.500
8110049	Pav Mrkg, Oly Cold Plastic, Direction Arrow Sym, Bike	Ea	1.000
8110058	Pav Mrkg, Oly Cold Plastic, Bike, Small Sym	Ea	1.000
8110153	Pav Mrkg, Sprayable Thermopl, 4 inch, White	Ft	1,961.000
8110154	Pav Mrkg, Sprayable Thermopl, 4 inch, Yellow	Ft	1,690.000
8110155	Pav Mrkg, Sprayable Thermopl, 6 inch, White	Ft	670.000
8110218	Pav Mrkg, Thermopl, 24 inch, Stop Bar	Ft	167.000
8117001	Pav Mrkg, Thermopl, 24 inch, Crosswalk	Ft	264.000
8117050	Pav Mrkg, Thermopl, Only	Ea	3.000
8117050	Pav Mrkg, Thermopl, School	Ea	3.000
8120012	Barricade, Type III, High Intensity, Double Sided, Lighted, Furn	Ea	8.000
8120013	Barricade, Type III, High Intensity, Double Sided, Lighted, Oper	Ea	8.000
8120140	Lighted Arrow, Type C, Furn	Ea	2.000
8120141	Lighted Arrow, Type C, Oper	Ea	2.000
8120210	Pav Mrkg, Longit, 6 inch or Less Width, Rem	Ft	40.000
8120260	Plastic Drum, High Intensity, Lighted, Furn	Ea	185.000
8120261	Plastic Drum, High Intensity, Lighted, Oper	Ea	185.000
8120330	Sign, Portable, Changeable Message, Furn	Ea	4.000
8120331	Sign, Portable, Changeable Message, Oper	Ea	4.000
8120350	Sign, Type B, Temp, Prismatic, Furn	Sft	419.000
8120351	Sign, Type B, Temp, Prismatic, Oper	Sft	419.000
8167011	Slope Restoration	Syd	477.000

CONSTRUCTION KEY	
KEY	ASSOCIATED PAY ITEM(S)
AA	• Dr Structure, Adj, Case 1, Modified • Dr Structure, Adj, Case 2, Modified • Dr Structure, Temp Lowering, Modified
AB	• Dr Structure, Temp Lowering, Modified • Gate Box, Adj, Case 1 • Gate Box, Adj, Case 2 • Monument Box Adjust
ADST	• Dr Structure, Adj, Add Depth, Modified
AK	• Dr Structure, Adj, Case 1, Modified
C4	• Sidewalk, Sidewalk Ramp, and Driveway Approach, Any Thickness, Rem • Grading, Sidewalk • Sidewalk, Conc, 4 inch, Modified
C4HE	• Sidewalk, Sidewalk Ramp, and Driveway Approach, Any Thickness, Rem • Grading, Sidewalk • Cement • Sidewalk, Conc, 4 inch, Modified
C6	• Sidewalk, Sidewalk Ramp, and Driveway Approach, Any Thickness, Rem • Grading, Sidewalk • Detectable Warning Surface, Modified • Sidewalk Ramp, Conc, 6 inch, Modified • Sidewalk, Conc, 6 inch, Modified
C8	• Grading, Driveway Approach • Driveway, Nonreinf Conc, 8 inch, Modified • Sidewalk, Sidewalk Ramp, and Driveway Approach, Any Thickness, Rem • Grading, Driveway Approach • Grading, Sidewalk • Grading, Sidewalk Ramp
CHE	• Cement • Driveway, Nonreinf Conc, 6 inch, Modified • Driveway, Nonreinf Conc, 8 inch, Modified • Detectable Warning Surface, Modified • Sidewalk Ramp, Conc, 6 inch, Modified • Sidewalk, Conc, 6 inch, Modified
C/G	• Curb, Gutter, and Curb and Gutter, Any Type, Rem • Curb and Gutter, Conc
C/GHE	• Curb, Gutter, and Curb and Gutter, Any Type, Rem • Cement • Driveway Opening, Conc, Det M, Modified
CP	• Grading, Sidewalk • Sidewalk, Conc, 4 inch, Modified
CR	• Sidewalk, Sidewalk Ramp, and Driveway Approach, Any Thickness, Rem • Dr Structure, Rem
DS	• Sewer, Rem, Less than 24 inch • Dr Structure, 24 inch dia • Dr Structure, Rem
DSDI	• Sewer, Rem, Less than 24 inch • Dr Structure, Double Inlet
PT	• Dr Structure, Point
RRA	• Dr Structure Cover, Type B • Dr Structure Cover, Type B, Special • Dr Structure, Adj, Case 1, Modified • Dr Structure, Temp Lowering, Modified
RRK	• Dr Structure Cover, Type K • Dr Structure, Adj, Case 1, Modified
RS	• Dr Structure, Reconstruct
TYPE I	• Plastic Drum, High Intensity, Lighted, Furn • Plastic Drum, High Intensity, Lighted, Oper
TYPE II	• Barricade, Type III, High Intensity, Double Sided, Lighted, Furn • Barricade, Type III, High Intensity, Double Sided, Lighted, Oper

LEGEND	
SYMBOL	DESCRIPTION
⊙	EXISTING SANITARY SEWER MANHOLE
⊕	EXISTING STORM SEWER MANHOLE
⊗	EXISTING WATER MAIN VALVE IN WELL
+	WATER MAIN GATE VALVE IN BOX
⊕	FIRE HYDRANT
⊙	MICHCON GAS CO. VALVE BOX/WELL
⊕	AMERITECH TELEPHONE VAULT
⊙	ELECTRIC MANHOLE
⊕	SOIL BORING
□	EXISTING STORM SEWER INLET
⊕	MONUMENT BOX
▬	REMOVE AND REPLACE CONC. SIDEWALK
▬	PLACE CONCRETE SIDEWALK
▬	REMOVE & REPLACE CONC. CURB & GUTTER
---	CONSTRUCTION LIMITS
---	6" WRAPPED UNDERDRAIN
▬	REMOVE CONCRETE SIDEWALK
▬	SUBGRADE UNDERCUT

QUANTITIES				
Sign, Type B, Temp, Prismatic				
Quantity	Sign Code	Description	Area (sft)	Total
17.0	D3-1	Street Name Sign	4.000	68.000
1.0	M4-10R	Detour Arrow (Right) Sign	6.000	6.000
1.0	M4-8a	End Detour Sign	3.000	3.000
6.0	M4-9L	Detour Sign (w/Left Arrow)	5.000	30.000
1.0	M4-9R	Detour Sign (w/Right Arrow)	5.000	5.000
1.0	M4-9S	Detour Sign (w/Thru Arrow)	5.000	5.000
6.0	R11-2	Road Closed Sign ("Road Closed")	8.000	48.000
1.0	R11-3a	Road Closed Sign ("Road Closed Local Traffic Only")	12.500	12.500
0.0	R11-4	Road Closed Sign ("Road Closed To Thru Traffic")	12.500	0.000
2.0	R2-1	Speed Limit (25 MPH)	5.000	10.000
2.0	R2-5B	Reduce Speed Ahead (25 MPH)	5.000	10.000
4.0	R3-1	Movement Prohibition Sign ("No Right Turn")	4.000	16.000
1.0	R3-2	Movement Prohibition Sign ("No Left Turn")	5.000	5.000
3.0	R3-8	Advance Intersection Lane Control Sign (Left Turn On y or Right Turn Only)	7.500	22.500
2.0	R5-18cLa	Work Zone Sign ("Work Zone Begins / Traffic Fines Doubled")	17.500	35.000
3.0	R6-1L	One Way (Left) Sign	3.000	9.000
5.0	R6-1R	One Way (Right) Sign	3.000	15.000
0.0	R6-2R	One Way	3.000	0.000
4.0	SP-1	Special Sign	20.000	80.000
1.0	W1-6R	One-Direction (Right) Large Arrow	3.000	3.000
0.0	W20-1	Road Work Ahead Sign	9.000	0.000
1.0	W20-3	Road Closed Ahead	9.000	9.000
1.0	W20-5	Lane Closed Sign ("Center Lane Closed Ahead")	9.000	9.000
1.0	W20-5	Lane Closed Sign ("Right Lane Closed Ahead")	9.000	9.000
1.0	W9-3L	Left Lane Closed Ahead	9.000	9.000
		TOTAL		419.000



PROJECT MANAGEMENT SERVICES UNIT
CITY OF ANN ARBOR PUBLIC SERVICES
301 EAST HURON STREET, P.O. BOX 8647
ANN ARBOR, MICHIGAN 48107-8647
734-794-6410 www.a2gov.org

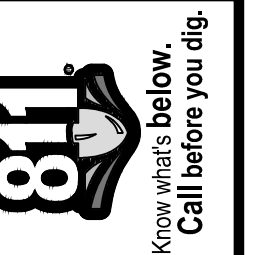

TAG	SIGN	NUM.
①		D3-1 M4-9S 30x24
②		D3-1 M4-9R 30x24
③		D3-1 M4-9L 30x24
⑥		D3-1 M4-8a 24X18
⑦		R11-4 60x30
⑧		SPECIAL 48x60
⑨		SPECIAL 48x60
⑫		SPECIAL 48x60

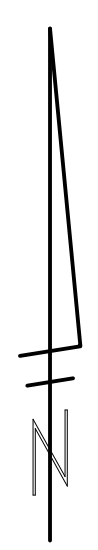
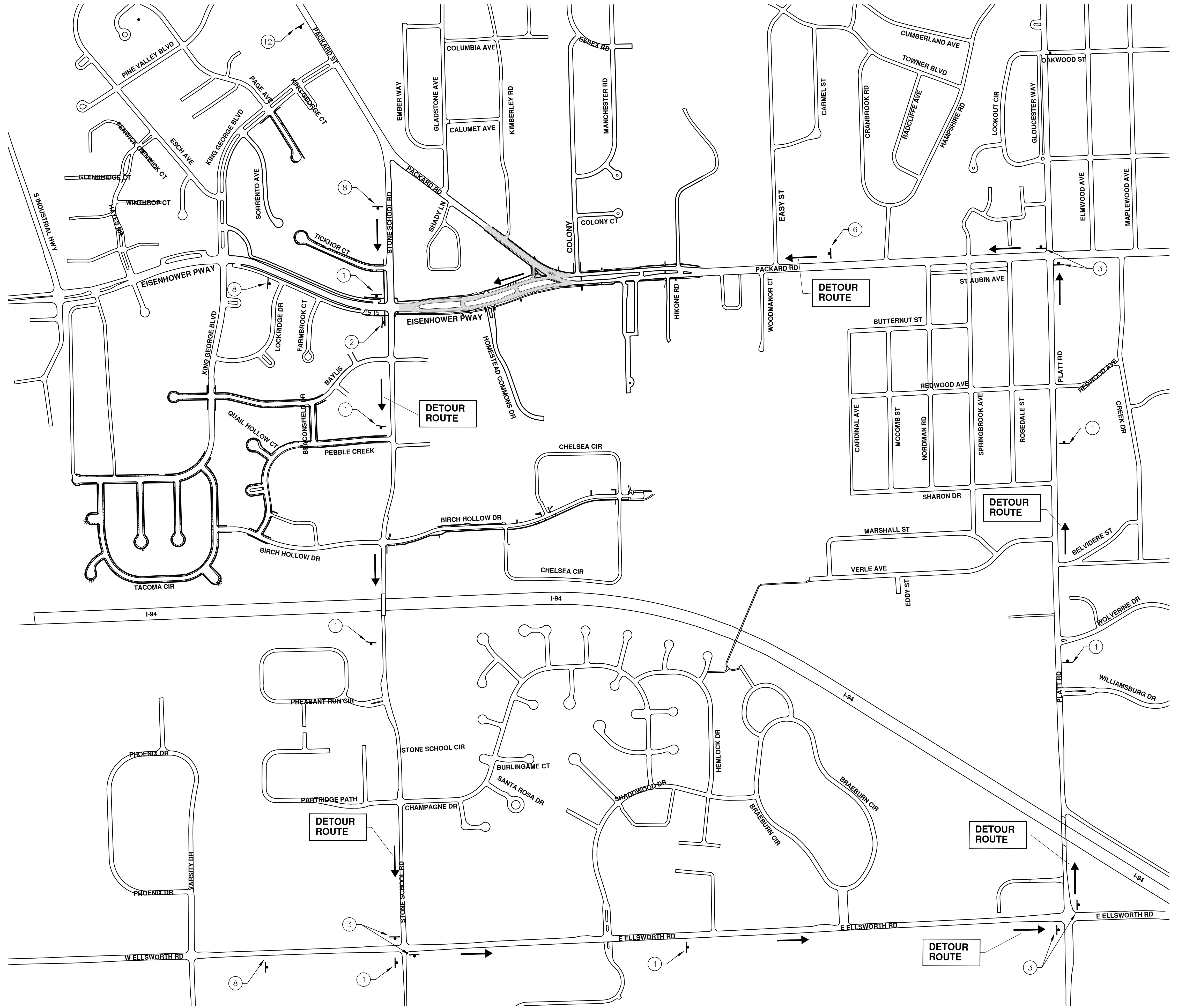

811
Know what's below. Call before you dig.

REV.	DESCRIPTION	DATE	DRAWN	CHECKED
02	ADDENDUM #3	3-15-2016	DAD	DAD
01	ADDENDUM #1	3-7-2016	DAD	DAD
00	BID SET	2-22-2016	GS AH UK	DAD

CITY OF ANN ARBOR
PUBLIC SERVICES
301 EAST HURON STREET
ANN ARBOR MI 48106-8647
www.a2gov.org

PROJECT MANAGEMENT - PUBLIC SERVICES - CITY OF ANN ARBOR
STREET RESURFACING - 2016
PACKARD ROAD & EISENHOWER PARKWAY

DETOUR

SCALE PLAN: Custom
DRAWING No. 2016004-73

SHEET No. 73 OF 98

S:\Project Management\Drafting\autocad\2016004\Plan Production\2016004-PACK.ARD.dwg Dwg Created: 18-Dec-15 - _02 standard bw.stb - Plot Date: 15-Mar-16

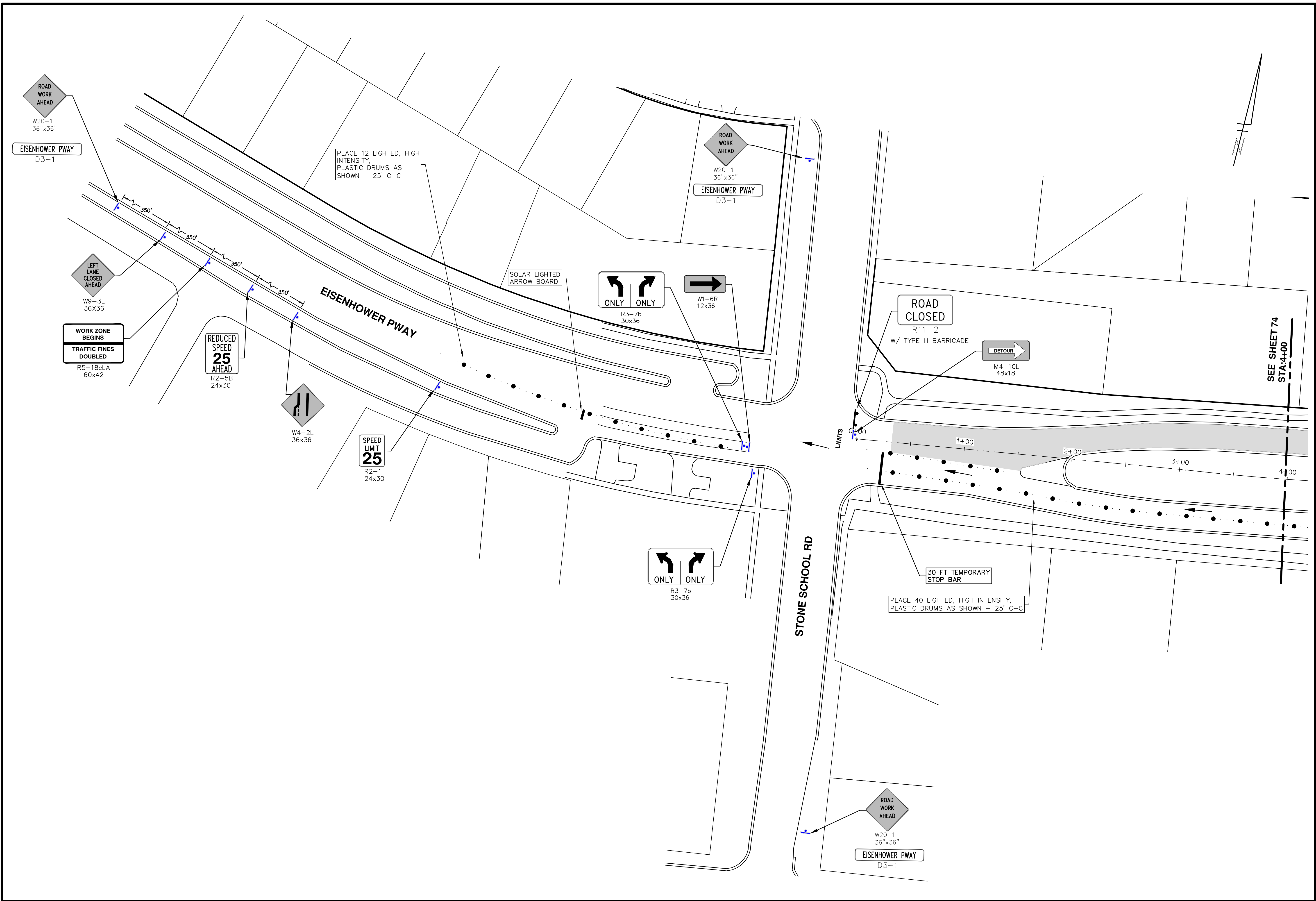

PROJECT MANAGEMENT - PUBLIC SERVICES - CITY OF ANN ARBOR
STREET RESURFACING - 2016
 PACKARD ROAD & EISENHOWER PARKWAY
 TRAFFIC CONTROL STAGE 1

811
 Know what's below.
 Call Before you dig.

REV.	DATE	DRAWN	CHECKED	DESCRIPTION
00	2-22-2016	SS AH UK	DAD	BID SET
01	3-7-2016	DAD	DAD	ADDENDUM #1
02	3-15-2016	DAD	DAD	ADDENDUM #3

CITY OF ANN ARBOR
 PUBLIC SERVICES
 301 EAST HURON STREET
 ANN ARBOR, MI 48106-0667
 ANN ARBOR: 734.794.4410
 WWW.A2GPOV.ORG

SCALE PLAN: 1" = 40'
 DRAWING No. 2016004-74

SHEET No. 74 OF 98

S:\Project Management\Drafting\autocad\2016004\Plan Production\2016004-PACK-ARD.dwg Dwg Created: 18-Dec-15 - _g2 standard bw.stb - Plot Date: 15-Mar-16

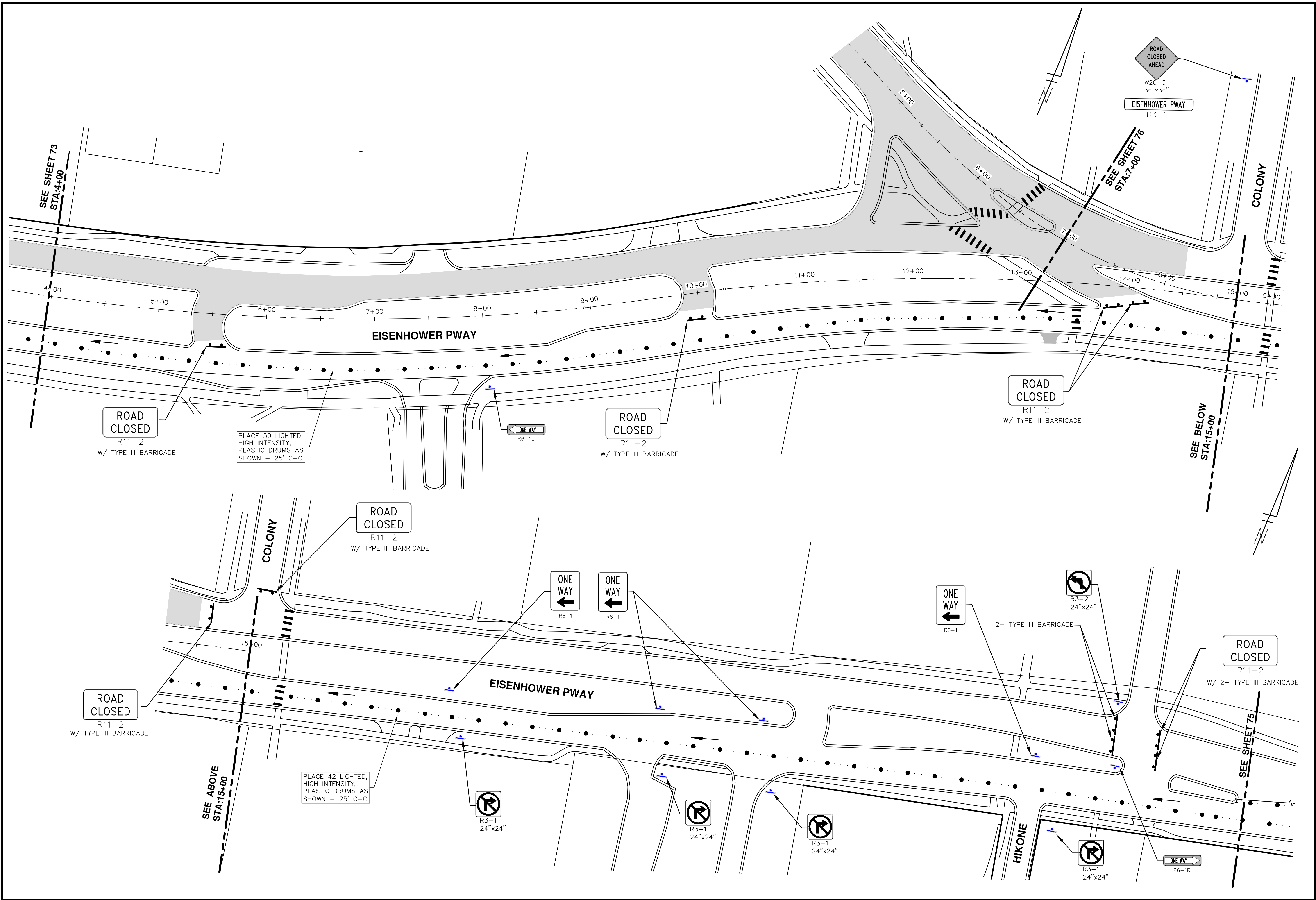

PROJECT MANAGEMENT - PUBLIC SERVICES - CITY OF ANN ARBOR
STREET RESURFACING - 2016
 PACKARD ROAD & EISENHOWER PARKWAY

TRAFFIC CONTROL STAGE 1

SCALE PLAN: 1" = 40'

DRAWING No. 2016004-75

SHEET No. 75 OF 98

811
 Know what's below.
 Call Before you dig.

REV.	DATE	DESCRIPTION	DRAWN	CHECKED
02	3-15-2016	ADDENDUM #3	DAD	DAD
01	3-7-2016	ADDENDUM #1	DAD	DAD
00	2-22-2016	BID SET	GS AH UK	DAD

CITY OF ANN ARBOR
 PUBLIC SERVICES
 301 EAST HURON STREET
 ANN ARBOR, MI 48106-6647
 ANN ARBOR, MI 48106-6647
 www.a2gov.org

CITY OF ANN ARBOR
 PUBLIC SERVICES
 301 EAST HURON STREET
 ANN ARBOR, MI 48106-6647
 ANN ARBOR, MI 48106-6647
 www.a2gov.org

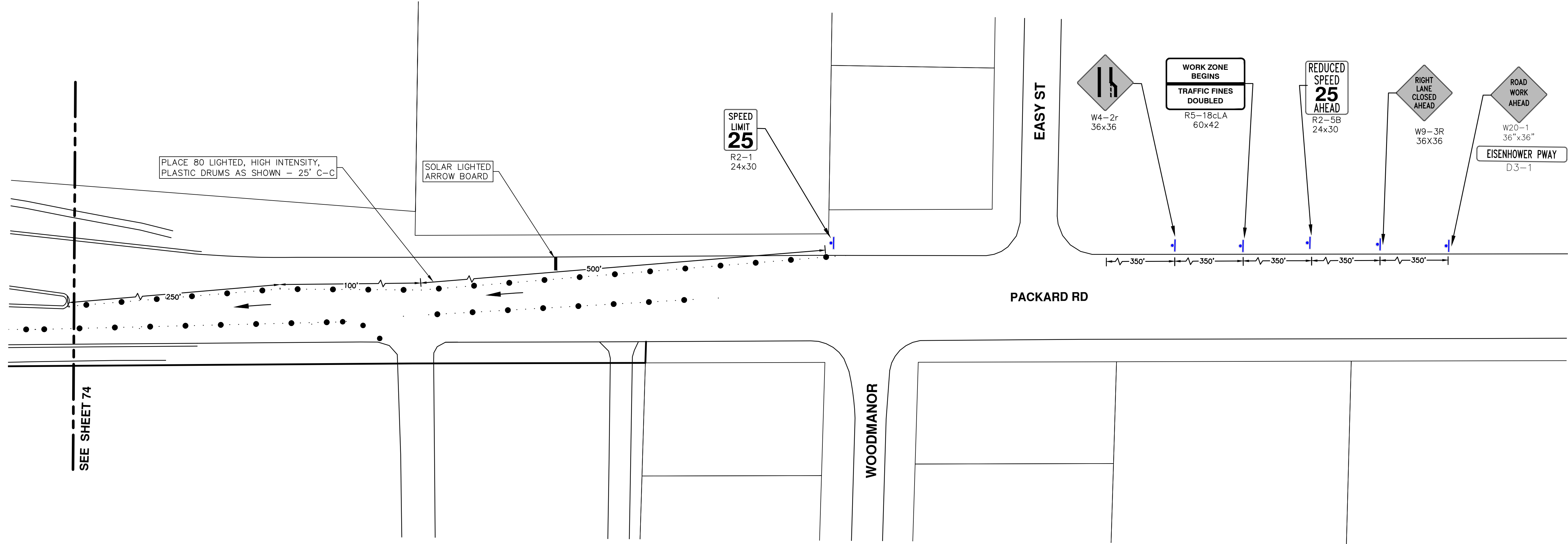

REV.	DESCRIPTION	DATE	DRAWN	CHECKED
02	ADDENDUM #3	3-15-2016	DAD	DAD
01	ADDENDUM #1	3-7-2016	DAD	DAD
00	BID SET	2-22-2016	SS AH JK	DAD

S:\Project Management\Drafting\autocad\2016004\Plan Production\2016004-PACKARD.dwg Dwg Created: 18-Dec-15 - _g2 standard bw.stb - Plot Date: 15-Mar-16

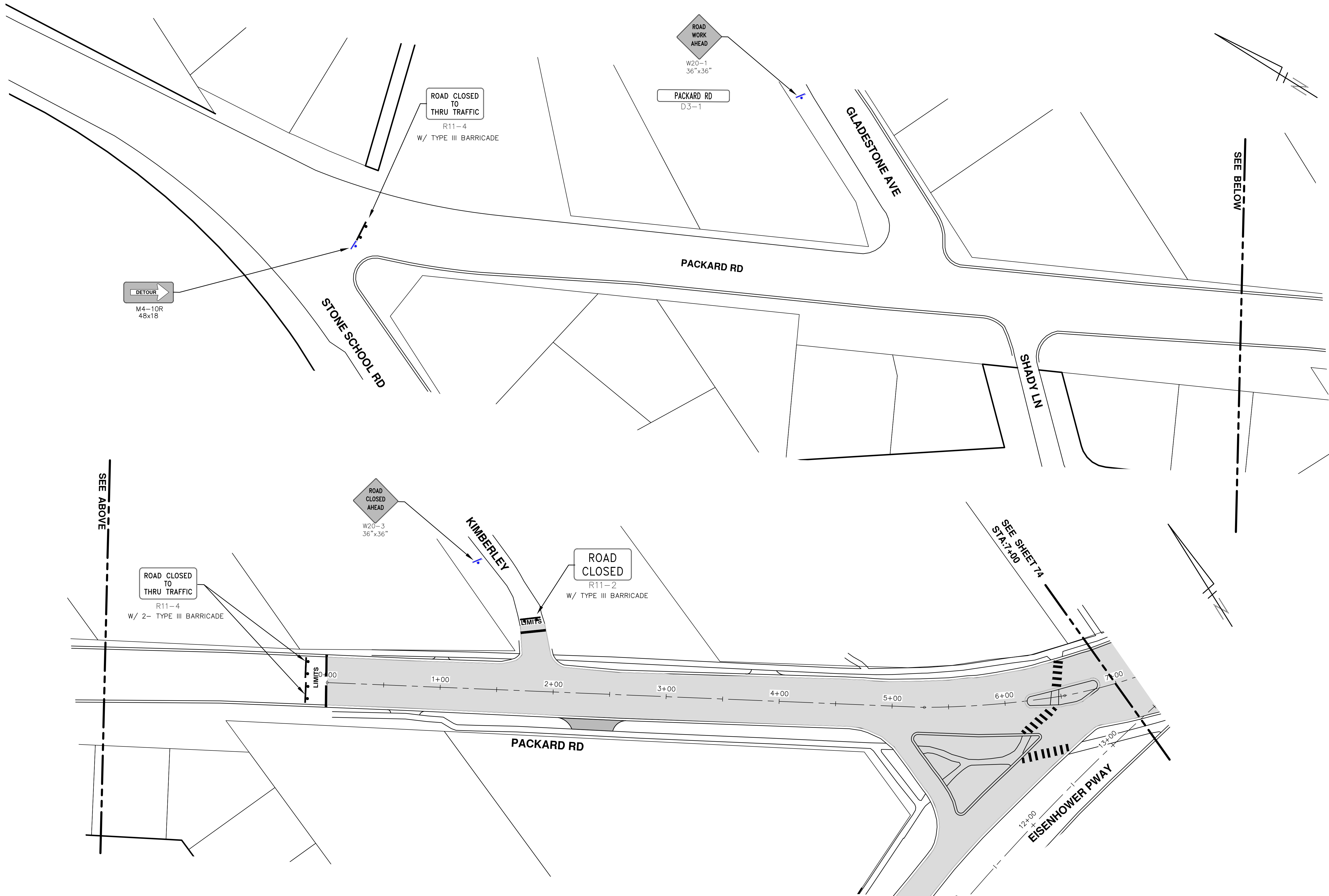

 CITY OF ANN ARBOR PUBLIC SERVICES 301 EAST HURON STREET ANN ARBOR, MI 48106-1667 www.a2gov.org		ADDENDUM #3 3-15-2016 DAD
ADDENDUM #1 3-7-2016 DAD		DAD
BID SET 2-22-2016 DATE		DAD
DESCRIPTION TRAFFIC CONTROL STAGE 1		DRAWN CHECKED

PROJECT MANAGEMENT - PUBLIC SERVICES - CITY OF ANN ARBOR
STREET RESURFACING - 2016
 PACKARD ROAD & EISENHOWER PARKWAY
 TRAFFIC CONTROL STAGE 1

SCALE PLAN: 1" = 40'
 DRAWING No. 2016004-77

SHEET No. 77 OF 98

S:\Project Management\Drafting\autocad\2016004\Plan Production\2016004-PACK.ARD.dwg Dwg Created: 18-Dec-15 - _g2 standard bw.stb - Plot Date: 15-Mar-16

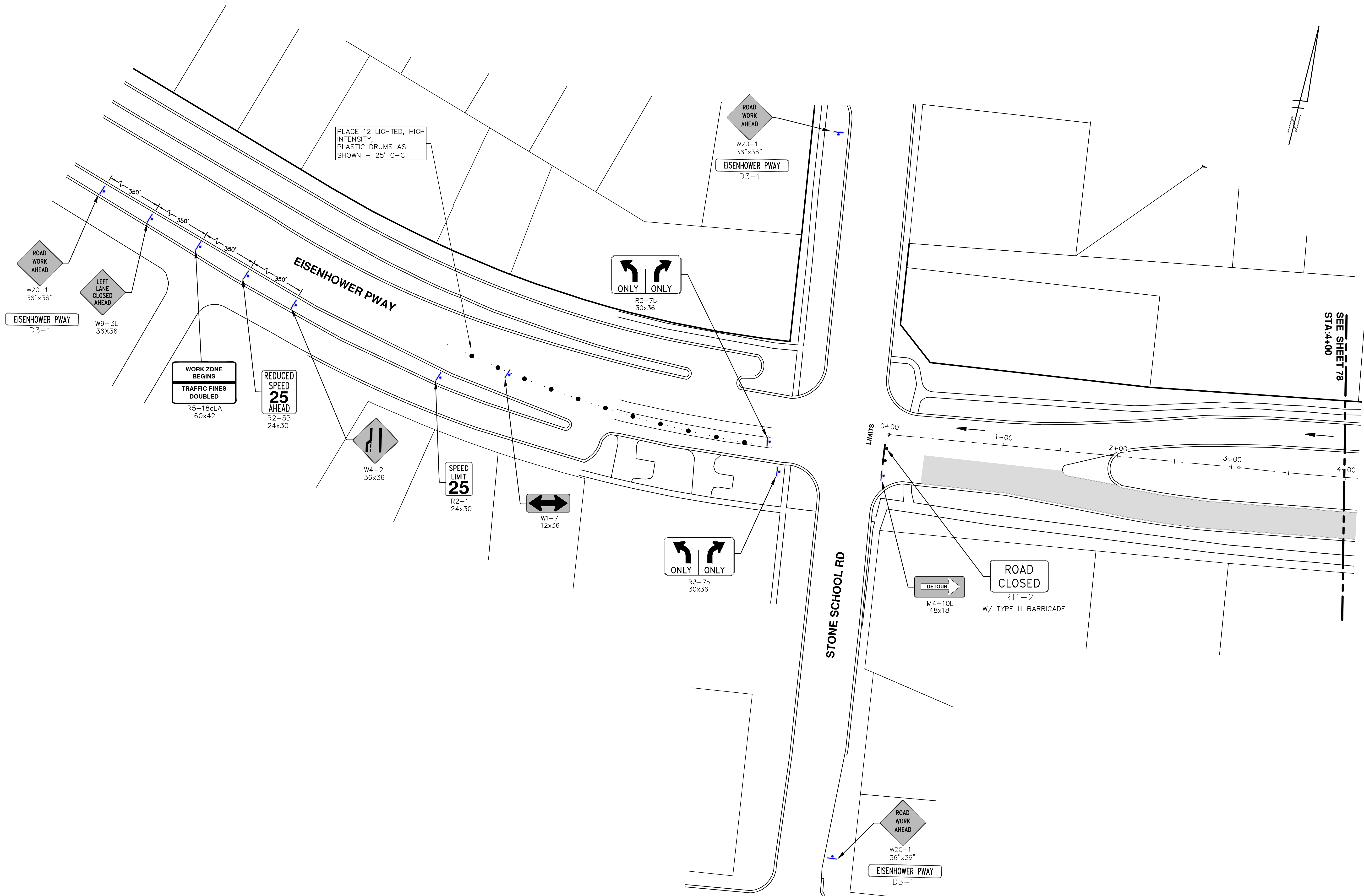

 Know what's below. Call before you dig.				
REV.	DESCRIPTION	DATE	DRAWN	CHECKED
02	ADDENDUM #3	3-15-2016	DAD	DAD
01	ADDENDUM #1	3-7-2016	DAD	DAD
00	BID SET	2-22-2016	GS AH JK	DAD

CITY OF ANN ARBOR
 PUBLIC SERVICES
 301 EAST HURON STREET
 P.O. BOX 8647
 ANN ARBOR, MI 48108-8647
 www.a2gov.org

PROJECT MANAGEMENT - PUBLIC SERVICES - CITY OF ANN ARBOR
STREET RESURFACING - 2016
 PACKARD ROAD & EISENHOWER PARKWAY
 TRAFFIC CONTROL STAGE II

SCALE PLAN: 1" = 40'
 DRAWING No. 2016004-78
 SHEET No. 78 OF 98

S:\Project Management\Drafting\autocad\2016004\Plan Production\2016004-PACKARD.dwg Dwg Created: 18-Dec-15 - _g2 standard bw.stb - Plot Date: 15-Mar-16

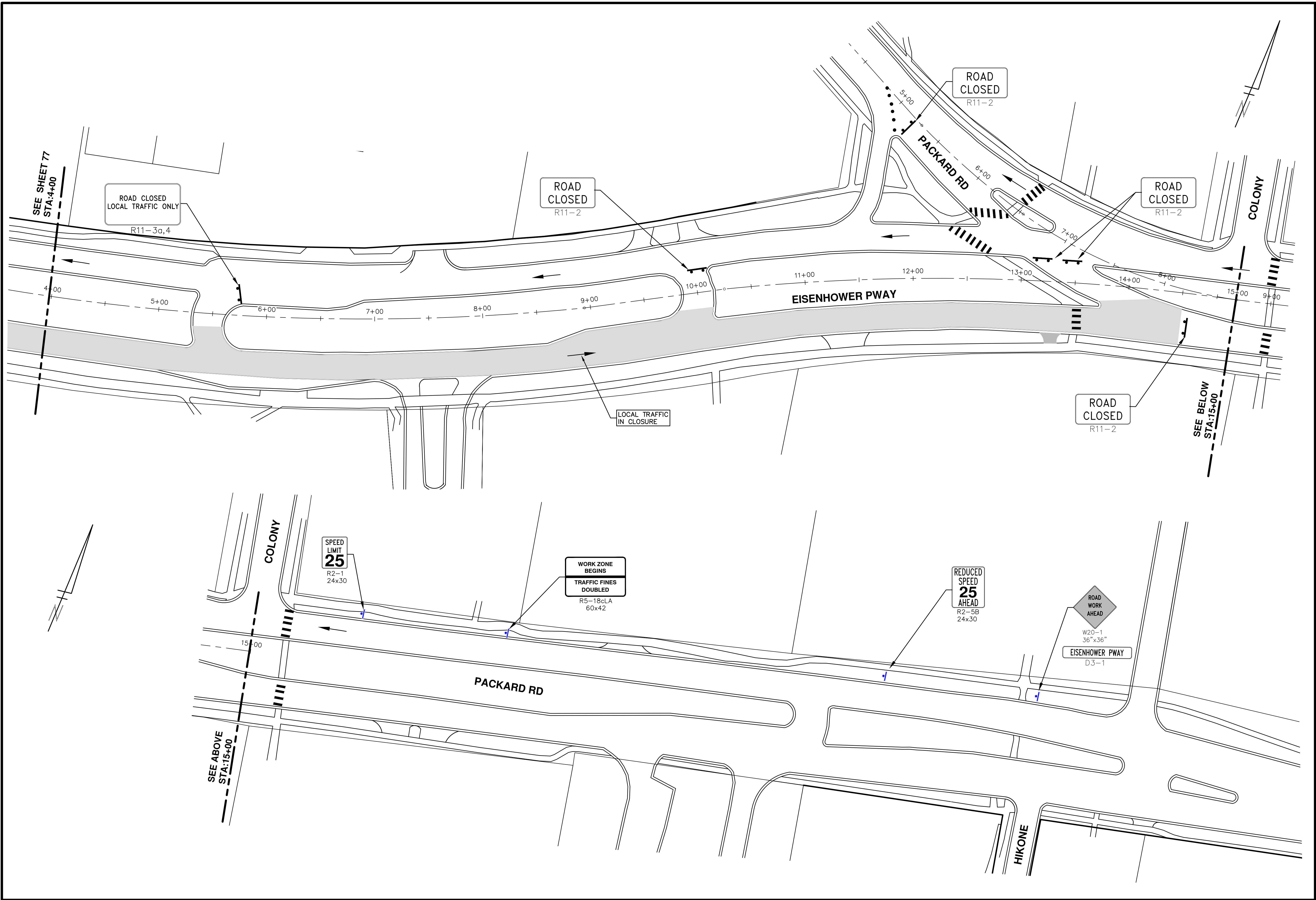

PROJECT MANAGEMENT - PUBLIC SERVICES - CITY OF ANN ARBOR
STREET RESURFACING - 2016
 PACKARD ROAD & EISENHOWER PARKWAY
 TRAFFIC CONTROL STAGE II

SCALE PLAN: 1" = 40'
 DRAWING No. 2016004-79

811
 Know what's below.
 Call Before you dig.

REV.	DESCRIPTION	DATE	DRAWN	CHECKED
02	ADDENDUM #3	3-15-2016	DAD	DAD
01	ADDENDUM #1	3-7-2016	DAD	DAD
00	BID SET	2-22-2016	GS AH JK	DAD

CITY OF ANN ARBOR
 PUBLIC SERVICES
 301 EAST HURON STREET
 P.O. BOX 86400
 ANN ARBOR MI 48108-6647
 www.a2gov.org

CITY OF ANN ARBOR MICHIGAN

S:\Project Management\Drafting\autocad\2016004\Plan Production\2016004-PACKARD.dwg Dwg Created: 18-Dec-15 - _g2 standard bw.stb - Plot Date: 15-Mar-16

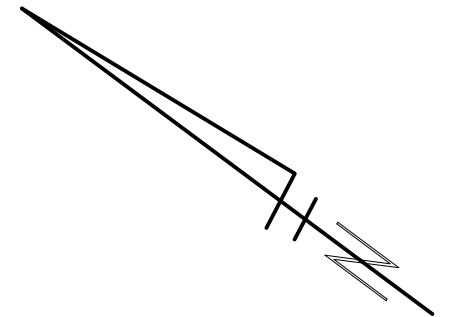
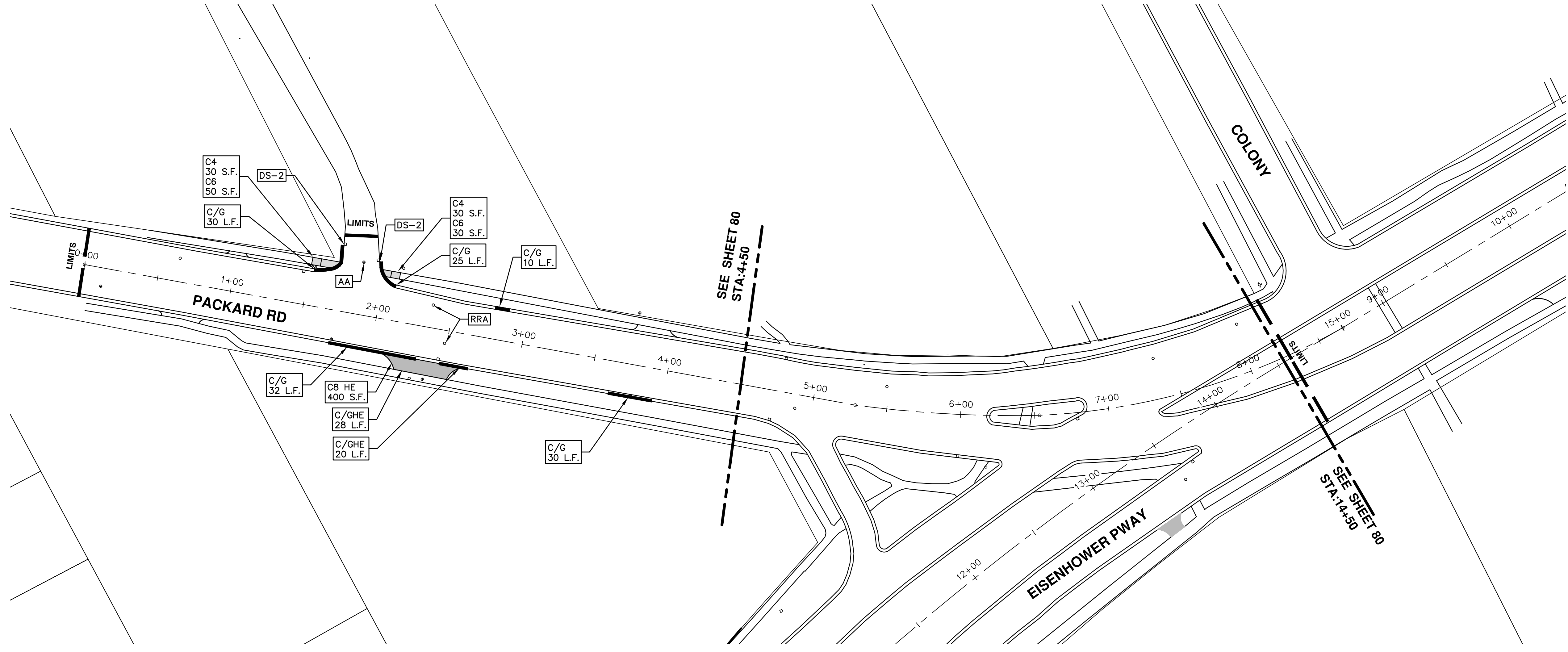

PROJECT MANAGEMENT - PUBLIC SERVICES - CITY OF ANN ARBOR
 STREET RESURFACING - 2016
 PACKARD ROAD & EISENHOWER PARKWAY
 SCALE PLAN: 1" = 40'
 DRAWING No. 2016004-80

CITY OF ANN ARBOR
 PUBLIC SERVICES
 301 EAST HURON STREET
 ANN ARBOR, MI 48106-0667
 www.a2gov.org



REV. DESCRIPTION DATE DRAWN CHECKED

REV.	DESCRIPTION	DATE	DRAWN	CHECKED
02	ADDENDUM #3	3-15-2016	DAD	DAD
01	ADDENDUM #1	3-7-2016	DAD	DAD
00	BID SET	2-22-2016	GSS AH JK	DAD

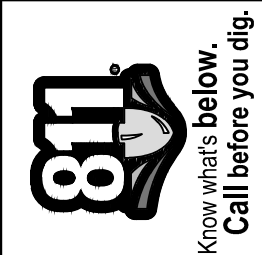

S:\Project Management\Drafting\autocad\2016004\Plan Production\2016004-PACKARD.dwg Dwg Created: 18-Dec-15 - _g2 standard bw.stb - Plot Date: 15-Mar-16

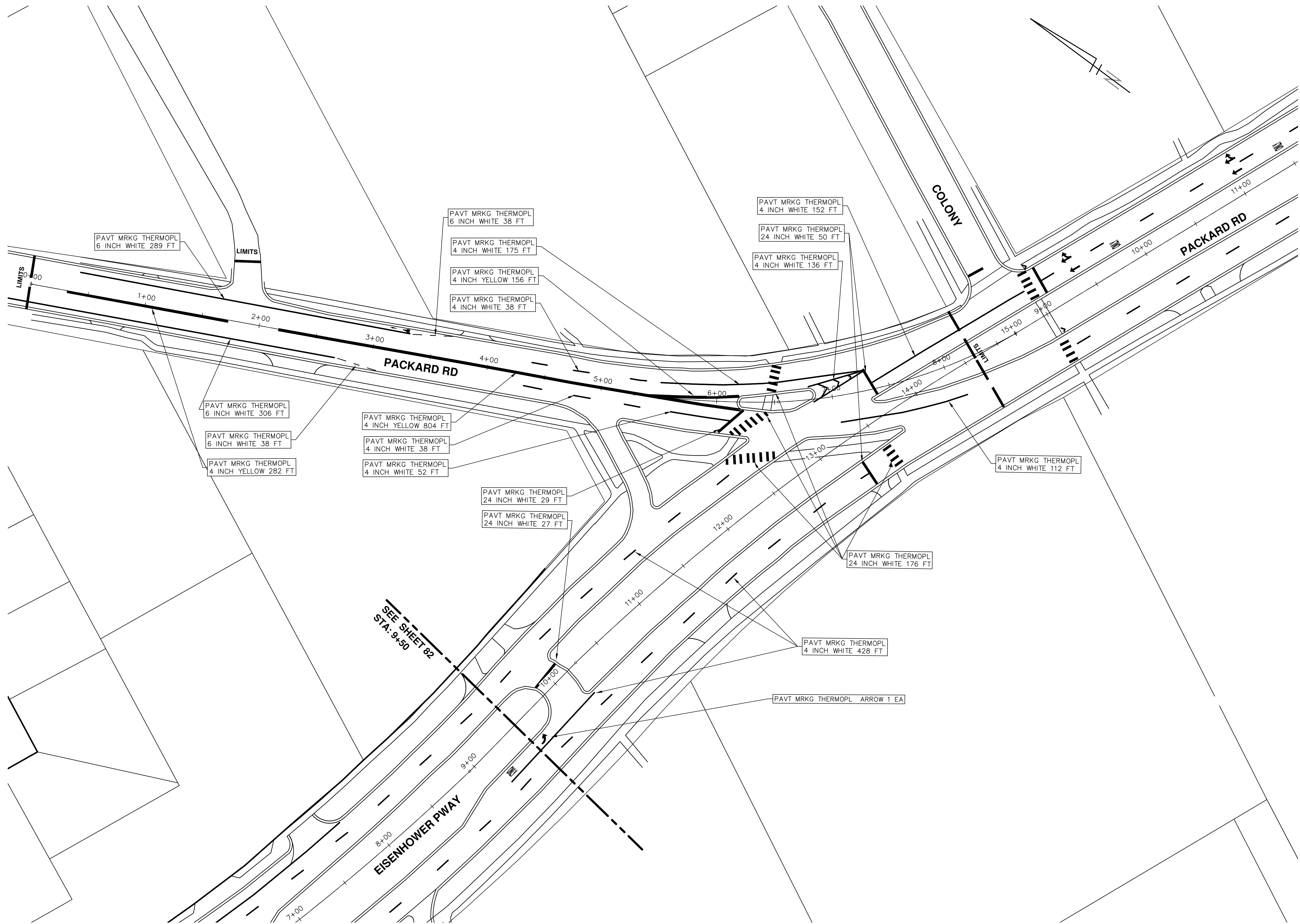

REV.	DESCRIPTION	DATE	DRAWN	CHECKED
02	ADDENDUM #3	3-15-2016	DAD	DAD
01	ADDENDUM #1	3-7-2016	DAD	DAD
00	BID SET	2-22-2016	SS AH JK	DAD

CITY OF ANN ARBOR
 PUBLIC SERVICES
 301 EAST HURON STREET
 ANN ARBOR MI 48106-8647
 www.a2gov.org



PROJECT MANAGEMENT - PUBLIC SERVICES - CITY OF ANN ARBOR
STREET RESURFACING - 2016
 PACKARD ROAD & EISENHOWER PARKWAY
 PAVEMENT MARKINGS

SCALE PLAN: 1" = 40'
 DRAWING No. 2016004-82

S:\Project Management\Drafting\autocad\2016004\Plan Production\2016004-PACK.ARD.dwg Dwg Created: 18-Dec-15 - _g2 standard bw.stb - Plot Date: 15-Mar-16

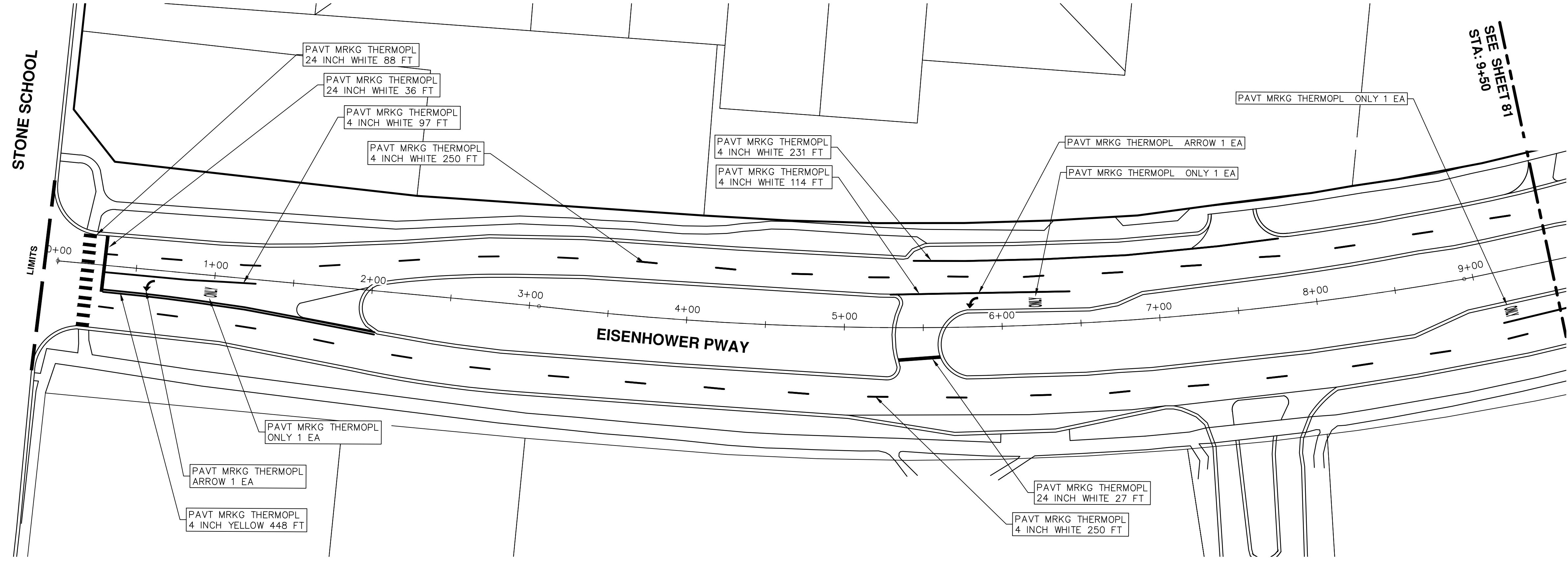

SEE SHEET 81
STA: 9+50

CITY OF ANN ARBOR
 PUBLIC SERVICES
 301 EAST HURON STREET
 ANN ARBOR, MI 48106-8647
 www.a2gov.org



REV.	DESCRIPTION	DATE	DRAWN	CHECKED
02	ADDENDUM #3	3-15-2016	DAD	DAD
01	ADDENDUM #1	3-7-2016	DAD	DAD
00	BID SET	2-22-2016	SS AH JK	DAD

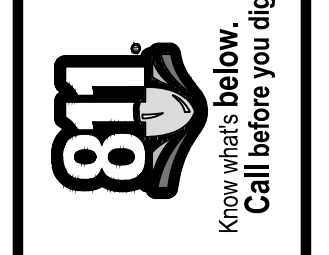



CITY OF ANN ARBOR

PROJECT MANAGEMENT

STREET RESURFACING - 2016

LOCATION: TACOMA CIRCLE

ITB No. 4422 FILE No. 2016004

QUANTITIES			
Item Code	Item Description	Units	Quantity
2030011	Dr Structure, Rem	Ea	6.000
2030015	Sewer, Rem, Less than 24 inch	Ft	60.000
2047001	Curb, Gutter, and Curb and Gutter, Any Type, Rem	Ft	1,741.000
2047011	Sidewalk, Sidewalk Ramp, and Driveway Approach, Any Thickness, Rem	Syd	67.000
2057011	Grading, Driveway Approach	Syd	72.000
2057011	Grading, Sidewalk	Syd	29.000
2057011	Grading, Sidewalk Ramp	Syd	42.000
2057011	Machine Grading, Special	Syd	9,344.000
2057021	Subgrade Undercutting, Type IIA	Cyd	785.000
4029987	Sewer, CI IV, 12 inch, Tr Det B	Ft	60.000
4030200	Dr Structure, 24 inch dia	Ea	6.000
4037050	Dr Structure Cover, Type B, Modified	Ea	7.000
4037050	Dr Structure Cover, Type K, Modified	Ea	8.000
4037050	Dr Structure, Adj, Case 1, Modified	Ea	24.000
4037050	Dr Structure, Temp Lowering, Modified	Ea	9.000
5010003	Cold Milling HMA Surface	Ton	2,112.000
5010005	HMA Surface, Rem	Syd	194.000
5010703	HMA, LVSP	Ton	2,112.000
6027021	Flowable Fill	Cyd	64.481
6030005	Cement	Ton	5.000
8017011	Driveway, Nonreinf Conc, 6 inch, Modified	Syd	72.000
8027001	Curb and Gutter, Conc	Ft	1,700.000
8027001	Driveway Opening, Conc, Det M, Modified	Ft	50.000
8037001	Detectable Warning Surface, Modified	Ft	30.000
8037010	Sidewalk Ramp, Conc, 6 inch, Modified	Sft	374.000
8037010	Sidewalk, Conc, 4 inch, Modified	Sft	185.000
8037010	Sidewalk, Conc, 6 inch, Modified	Sft	71.500
8110197	Pavt Mrkg, Thermopl, 6 inch, Crosswalk	Ft	135.000
8110218	Pavt Mrkg, Thermopl, 24 inch, Stop Bar	Ft	32.000
8120012	Barricade, Type III, High Intensity, Double Sided, Lighted, Furn	Ea	4.000
8120013	Barricade, Type III, High Intensity, Double Sided, Lighted, Oper	Ea	4.000
8120260	Plastic Drum, High Intensity, Lighted, Furn	Ea	110.000
8120261	Plastic Drum, High Intensity, Lighted, Oper	Ea	110.000
8120350	Sign, Type B, Temp, Prismatic, Furn	Sft	167.500
8120351	Sign, Type B, Temp, Prismatic, Oper	Sft	167.500
8127050	No Parking Sign	Ea	66.000
8167011	Slope Restoration	Syd	639.000

CONSTRUCTION KEY	
KEY	ASSOCIATED PAY ITEM(S)
AA	• Dr Structure, Adj, Case 1, Modified • Dr Structure, Adj, Case 2, Modified • Dr Structure, Temp Lowering, Modified
AB	• Dr Structure, Temp Lowering, Modified • Gate Box, Adj, Case 1 • Gate Box, Adj, Case 2 • Monument Box Adjust
ADST	• Dr Structure, Adj, Add Depth, Modified
AK	• Dr Structure, Adj, Case 1, Modified
C4	• Sidewalk, Sidewalk Ramp, and Driveway Approach, Any Thickness, Rem • Grading, Sidewalk • Sidewalk, Conc, 4 inch, Modified
C4HE	• Sidewalk, Sidewalk Ramp, and Driveway Approach, Any Thickness, Rem • Grading, Sidewalk • Cement • Sidewalk, Conc, 4 inch, Modified
C6	• Sidewalk, Sidewalk Ramp, and Driveway Approach, Any Thickness, Rem • Grading, Sidewalk • Sidewalk Ramp • Detectable Warning Surface, Modified • Sidewalk Ramp, Conc, 6 inch, Modified • Sidewalk, Conc, 6 inch, Modified
C8	• Grading, Driveway Approach • Driveway, Nonreinf Conc, 8 inch, Modified • Sidewalk, Sidewalk Ramp, and Driveway Approach, Any Thickness, Rem • Grading, Driveway Approach • Grading, Sidewalk • Grading, Sidewalk Ramp
CHE	• Cement • Driveway, Nonreinf Conc, 6 inch, Modified • Driveway, Nonreinf Conc, 8 inch, Modified • Detectable Warning Surface, Modified • Sidewalk Ramp, Conc, 6 inch, Modified • Sidewalk, Conc, 6 inch, Modified
C/G	• Curb, Gutter, and Curb and Gutter, Any Type, Rem • Curb and Gutter, Conc
C/GHE	• Curb, Gutter, and Curb and Gutter, Any Type, Rem • Cement • Driveway Opening, Conc, Det M, Modified
CP	• Grading, Sidewalk • Sidewalk, Conc, 4 inch, Modified
CR	• Sidewalk, Sidewalk Ramp, and Driveway Approach, Any Thickness, Rem • Dr Structure, Rem
DS	• Sewer, Rem, Less than 24 inch • Dr Structure, 24 inch dia • Dr Structure, Rem
DSDI	• Sewer, Rem, Less than 24 inch • Dr Structure, Double Inlet
PT	• Dr Structure, Point • Dr Structure Cover, Type B • Dr Structure Cover, Type B, Special • Dr Structure, Adj, Case 1, Modified • Dr Structure, Temp Lowering, Modified
RRK	• Dr Structure Cover, Type K • Dr Structure, Adj, Case 1, Modified
RS	• Dr Structure, Reconstruct
TYPE II	• Plastic Drum, High Intensity, Lighted, Furn • Plastic Drum, High Intensity, Lighted, Oper
TYPE III	• Barricade, Type III, High Intensity, Double Sided, Lighted, Furn • Barricade, Type III, High Intensity, Double Sided, Lighted, Oper

LEGEND	
SYMBOL	DESCRIPTION
⊙	EXISTING SANITARY SEWER MANHOLE
⊕	EXISTING STORM SEWER MANHOLE
⊗	EXISTING WATER MAIN VALVE IN WELL
+	WATER MAIN GATE VALVE IN BOX
⊕	FIRE HYDRANT
⊙	MICHCON GAS CO. VALVE BOX/WELL
⊕	AMERITECH TELEPHONE VAULT
⊙	ELECTRIC MANHOLE
⊕	SOIL BORING
□	EXISTING STORM SEWER INLET
⊕	MONUMENT BOX
▬	REMOVE AND REPLACE CONC. SIDEWALK
▬	PLACE CONCRETE SIDEWALK
▬	REMOVE & REPLACE CONC. CURB & GUTTER
▬	CONSTRUCTION LIMITS
▬	6" WRAPPED UNDERDRAIN
▬	REMOVE CONCRETE SIDEWALK
▬	SUBGRADE UNDERCUT

QUANTITIES				
Sign, Type B, Temp, Prismatic				
Quantity	Sign Code	Description	Area (sft)	Total
10.0	D3-1	Street Name Sign	4.000	40.000
3.0	R11-4	Road Closed Sign ("Road Closed To Thru Traffic")	12.500	37.500
5.0	W20-1	Road Work Ahead Sign	9.000	45.000
5.0	W20-3	Road Closed Ahead Sign	9.000	45.000
		TOTAL		167.500

CONSTRUCTION METHOD AND SEQUENCING

WORK ON THIS STREET INCLUDES, BUT IS NOT LIMITED TO, THE FOLLOWING ITEMS. COMPLETE THE WORK IN ACCORDANCE WITH THE PLANS AND SPECIFICATIONS, AND AS DIRECTED BY THE ENGINEER. PERFORM THE WORK IN THE ORDER INDICATED BELOW UNLESS OTHERWISE AUTHORIZED OR DIRECTED BY THE ENGINEER.

- IMPLEMENT MAINTENANCE OF TRAFFIC (M.O.T.) PLAN, AND INSTALL SOIL EROSION AND SEDIMENTATION CONTROL MEASURES.
- CONDUCT REMOVAL WORK RELATED TO PAVEMENT, DRAINAGE, AND CONCRETE ITEMS WITH EXCEPTION TO COLDMILLING.
- INSTALL PROPOSED DRAINAGE STRUCTURES, STORM SEWER, AND UNDERDRAIN AS REQUIRED.
- PERFORM ALL CONCRETE WORK, INCLUDING RESTORATION, AS REQUIRED.
- TEMPORARY LOWER ALL STRUCTURE COVERS LOCATED WITHIN THE EXISTING PAVEMENT, INCLUDING GATE AND MONUMENT BOXES AS REQUIRED.
- REMOVE 4.0 INCHES OF EXISTING HMA SURFACE BY COLDMILLING. THIS MAY INCLUDE GRANULAR BASE MATERIAL. DEPTH TO BE DETERMINED BY THE ENGINEER. PROOF ROLL WITH FULLY LOADED TRUCK.
- PERFORM ALL JOINT AND CRACK CLEANOUT, HMA/HAND PATCHING, UNDERCUTS AND/OR BASE REPAIRS AS REQUIRED.
- GRADE, SHAPE, AND COMPACT THE EXISTING BASE MATERIAL AS REQUIRED.
- CLEAN PAVEMENT AS REQUIRED, AND PLACE 2.0 INCH LEVELING COURSE HMA MIX (LOCAL STREETS).
- ADJUST ALL STRUCTURE COVERS, INCLUDING GATE AND MONUMENT BOXES, TO THEIR FINISHED ELEVATIONS AS REQUIRED.
- CLEAN PAVEMENT AND PLACE 2.0 INCH TOP COURSE HMA MIX (LOCAL STREETS).
- CLEAN PAVEMENT AND COMPLETE ALL PAVEMENT MARKINGS.
- COMPLETE ALL MISCELLANEOUS CONSTRUCTION INCLUDING ALL CLEAN UP AND FINAL RESTORATION.
- REMOVE ALL TRAFFIC CONTROL DEVICES, AND MISS DIG FLAGS.

NOTES

FOR PROTECTION OF UNDERGROUND UTILITIES AND IN CONFORMANCE WITH PUBLIC ACT 174 OF 2013, THE CONTRACTOR SHALL CALL 811 OR 1-800-482-7171 A MINIMUM OF THREE FULL WORKING DAYS, EXCLUDING SATURDAYS, SUNDAYS, AND HOLIDAYS, PRIOR TO BEGINNING EACH EXCAVATION IN AREAS WHERE PUBLIC UTILITIES HAVE NOT BEEN PREVIOUSLY LOCATED. MEMBERS WILL THUS BE ROUTINELY NOTIFIED. THIS DOES NOT RELIEVE THE CONTRACTOR OF THE RESPONSIBILITY OF NOTIFYING UTILITY OWNERS WHO MAY NOT BE A PART OF THE "MISS DIG" ALERT SYSTEM.

THE UNDERGROUND LOCATIONS SHOWN FOR NATURAL GAS, TELEPHONE, ELECTRICAL POWER, CABLE TV AND FIBER OPTIC LINES ARE APPROXIMATE. THE CITY OF ANN ARBOR ASSUMES NO RESPONSIBILITY FOR THEIR ACCURATE REPRESENTATION IN THIS DRAWING. MISS DIG MUST BE CONTACTED PRIOR TO CONSTRUCTION TO LOCATE THESE UTILITIES.

THE IMPROVEMENTS COVERED BY THESE PLANS SHALL BE PERFORMED IN ACCORDANCE WITH MICHIGAN DEPARTMENT OF TRANSPORTATION (MDOT) 2012 STANDARD SPECIFICATIONS FOR CONSTRUCTION, INCLUDING REFERENCED MDOT PUBLICATIONS, AND THE PROJECT CONTRACT DOCUMENTS.



PROJECT MANAGEMENT SERVICES UNIT
 CITY OF ANN ARBOR PUBLIC SERVICES
 301 EAST HURON STREET, P.O. BOX 8647
 ANN ARBOR, MICHIGAN 48107-8647
 734-794-6410 www.a2gov.org

S:\Project Management\Drafting\autocad\2016004\Plan Production\2016004-TACOMA CIR.dwg Dwg Created: 30-Nov-15 - _a2 standard bw.stb - Plot Date: 15-Mar-16

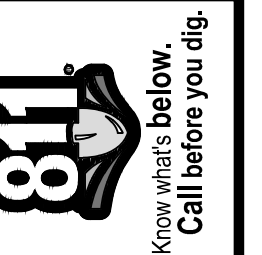

PROJECT MANAGEMENT - PUBLIC SERVICES - CITY OF ANN ARBOR
 STREET RESURFACING - 2016
 TACOMA CIRCLE
 PROJECT DESCRIPTION
 DRAWING No. 2016004-84

S:\Project Management\Drafting\autocad\2016004\Plan Production\2016004-TACOMA CIR.dwg Dwg Created: 30-Nov-15 - _a2 standard bw.stb - Plot Date: 15-Mar-16

TRAFFIC CONTROL SIGN		
	SIGN	NUMBER
①		R11-4 60x30
②		R11-2 60x30
③		W20-3 36"x36" D3-1
④		W20-1 36"x36" D3-1
⑤	W/ TYPE III BARRICADE	

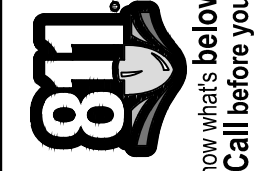
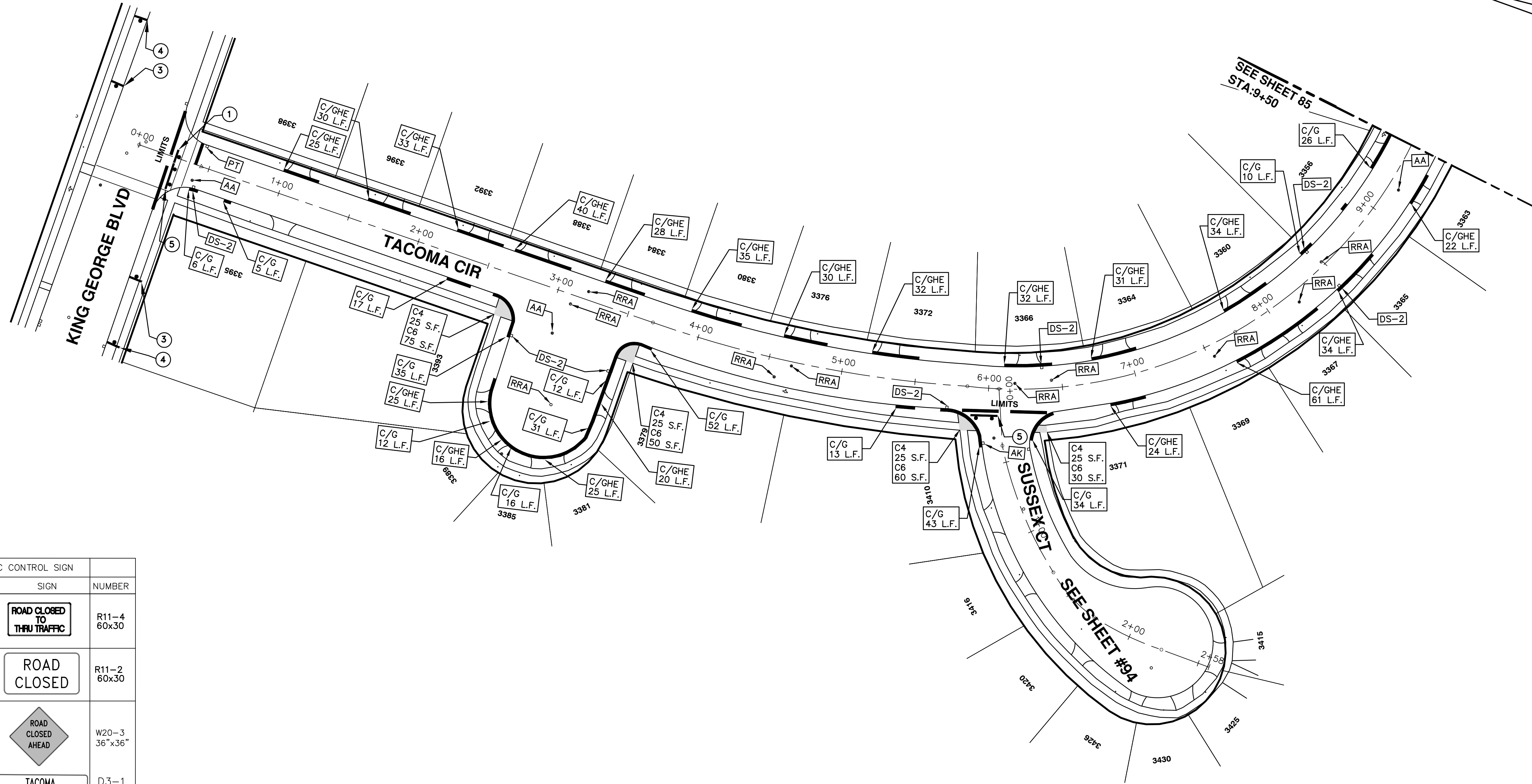

Know what's below.
Call Before you dig.

REV.	DESCRIPTION	DATE	DRAWN	CHECKED
02	ADDENDUM #3	3-15-2016	DAD	DAD
01	ADDENDUM #1	3-7-2016	DAD	DAD
00	BID SET	2-22-2016	GS AH JK	DAD

CITY OF ANN ARBOR
PUBLIC SERVICES
301 EAST HURON STREET
PO BOX 8647
ANN ARBOR MI 48108-8647
www.a2gov.org



PROJECT MANAGEMENT - PUBLIC SERVICES - CITY OF ANN ARBOR
STREET RESURFACING - 2016
TACOMA CIRCLE
RESURFACING

SCALE PLAN: 1" = 40'
DRAWING No. 2016004-85

S:\Project Management\Drafting\autocad\2016004\Plan Production\2016004-TACOMA CIR.dwg Dwg Created: 30-Nov-15 - _a2 standard bw.stb - Plot Date: 15-Mar-16

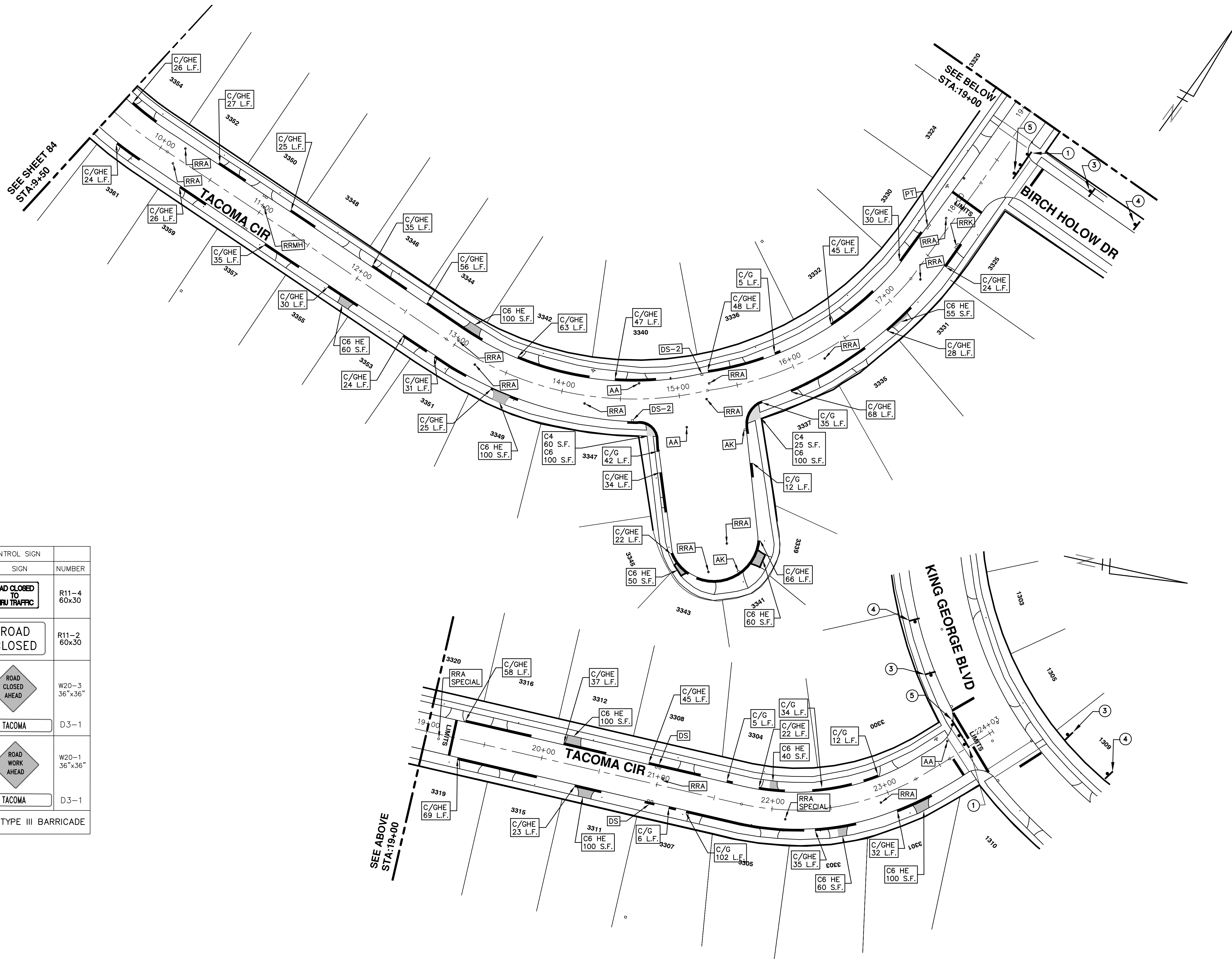

TRAFFIC CONTROL SIGN		
	SIGN	NUMBER
①		R11-4 60x30
②		R11-2 60x30
③		W20-3 36"x36" TACOMA D3-1
④		W20-1 36"x36" TACOMA D3-1
⑤	W/ TYPE III BARRICADE	



Know what's below.
Call Before you dig.

REV.	DATE	DESCRIPTION	DRAWN	CHECKED
02	3-15-2016	ADDENDUM #3	DAD	DAD
01	3-7-2016	ADDENDUM #1	DAD	DAD
00	2-22-2016	BID SET	SS AH JK	DAD

CITY OF ANN ARBOR
PUBLIC SERVICES
301 EAST HURON STREET
PO BOX 8647
ANN ARBOR MI 48108-8647
www.a2gov.org



PROJECT MANAGEMENT - PUBLIC SERVICES - CITY OF ANN ARBOR
STREET RESURFACING - 2016
TACOMA CIRCLE
RESURFACING

SCALE PLAN: 1" = 40'
DRAWING No. 2016004-86



CITY OF ANN ARBOR PROJECT MANAGEMENT STREET RESURFACING - 2016 LOCATION: BIRCH HOLLOW DRIVE

ITB No. 4422 FILE No. 2016004

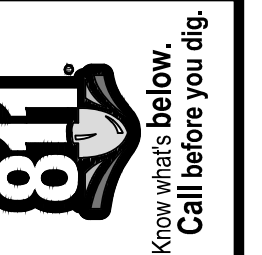

S:\Project Management\Drafting\autocad\2016004\Plan Production\2016004-Birch Hollow.dwg Dwg Created: 30-Nov-15 - _a2 standard bw.stb - Plot Date: 15-Mar-16

QUANTITIES			
Item Code	Item Description	Units	Quantity
2030011	Dr Structure, Rem	Ea	5.000
2030015	Sewer, Rem, Less than 24 inch	Ft	50.000
2047001	Curb, Gutter, and Curb and Gutter, Any Type, Rem	Ft	855.000
2047011	Sidewalk, Sidewalk Ramp, and Driveway Approach, Any Thickness, Rem	Syd	199.000
2057011	Grading, Driveway Approach	Syd	20.000
2057011	Grading, Sidewalk	Syd	52.000
2057011	Grading, Sidewalk Ramp	Syd	114.000
2057011	Machine Grading, Special	Syd	5,568.000
2057021	Subgrade Undercutting, Type IIA	Cyd	548.000
2087050	Erosion Control, Inlet Filter	Ea	11.000
4020987	Sewer, CI IV, 12 inch, Tr Det B	Ft	50.000
4032000	Dr Structure, 24 inch dia	Ea	5.000
4037050	Dr Structure Cover, Type D, Modified	Ea	1.000
4037050	Dr Structure Cover, Type K, Modified	Ea	9.000
4037050	Dr Structure, Adj, Case 1, Modified	Ea	13.000
4037050	Dr Structure, Point	Ea	1.000
4037050	Dr Structure, Temp Lowering, Modified	Ea	11.000
5010003	Cold Milling HMA Surface	Ton	1,259.000
5010005	HMA Surface, Rem	Syd	97.000
5010061	HMA, Approach	Ton	22.000
5010703	HMA, LVSP	Ton	1,237.000
6027021	Flowable Fill	Cyd	31.667
6030005	Cement	Ton	2.000
8017011	Driveway, Nonreinf Conc, 6 inch, Modified	Syd	20.000
8027001	Curb and Gutter, Conc	Ft	671.000
8027001	Driveway Opening, Conc, Det M, Modified	Ft	199.000
8037001	Detectable Warning Surface, Modified	Ft	30.000
8037010	Sidewalk Ramp, Conc, 6 inch, Modified	Sft	1,026.000
8037010	Sidewalk, Conc, 4 inch, Modified	Sft	445.000
8037010	Sidewalk, Conc, 6 inch, Modified	Sft	19.900
8110197	Pav Mrkg, Thermopl, 6 inch, Crosswalk	Ft	170.000
8110218	Pav Mrkg, Thermopl, 24 inch, Stop Bar	Ft	20.000
8120012	Barricade, Type III, High Intensity, Double Sided, Lighted, Furn	Ea	2.000
8120013	Barricade, Type III, High Intensity, Double Sided, Lighted, Oper	Ea	2.000
8120260	Plastic Drum, High Intensity, Lighted, Furn	Ea	40.000
8120261	Plastic Drum, High Intensity, Lighted, Oper	Ea	40.000
8120350	Sign, Type B, Temp, Prismatic, Furn	Sft	64.500
8120351	Sign, Type B, Temp, Prismatic, Oper	Sft	64.500
8127050	No Parking Sign	Ea	56.000
8167011	Slope Restoration	Syd	314.000
8230431	Gate Box, Adj, Case 1	Ea	3.000

CONSTRUCTION KEY	
KEY	ASSOCIATED PAY ITEM(S)
AA	• Dr Structure, Adj, Case 1, Modified • Dr Structure, Adj, Case 2, Modified • Dr Structure, Temp Lowering, Modified
AB	• Dr Structure, Temp Lowering, Modified • Gate Box, Adj, Case 1 • Gate Box, Adj, Case 2 • Monument Box Adjust
ADST	• Dr Structure, Adj, Add Depth, Modified
AK	• Dr Structure, Adj, Case 1, Modified
C4	• Sidewalk, Sidewalk Ramp, and Driveway Approach, Any Thickness, Rem • Grading, Sidewalk • Sidewalk, Conc, 4 inch, Modified
C4HE	• Sidewalk, Sidewalk Ramp, and Driveway Approach, Any Thickness, Rem • Grading, Sidewalk • Sidewalk, Conc, 4 inch, Modified
C6	• Sidewalk, Sidewalk Ramp, and Driveway Approach, Any Thickness, Rem • Grading, Sidewalk • Sidewalk Ramp • Detectable Warning Surface, Modified • Sidewalk Ramp, Conc, 6 inch, Modified • Sidewalk, Conc, 6 inch, Modified
C8	• Grading, Driveway Approach • Driveway, Nonreinf Conc, 8 inch, Modified • Sidewalk, Sidewalk Ramp, and Driveway Approach, Any Thickness, Rem • Grading, Driveway Approach • Grading, Sidewalk • Grading, Sidewalk Ramp
CHE	• Cement • Driveway, Nonreinf Conc, 6 inch, Modified • Driveway, Nonreinf Conc, 8 inch, Modified • Detectable Warning Surface, Modified • Sidewalk Ramp, Conc, 6 inch, Modified • Sidewalk, Conc, 6 inch, Modified
C/G	• Curb, Gutter, and Curb and Gutter, Any Type, Rem • Curb and Gutter, Conc
C/GHE	• Curb, Gutter, and Curb and Gutter, Any Type, Rem • Cement • Driveway Opening, Conc, Det M, Modified
CP	• Grading, Sidewalk • Sidewalk, Conc, 4 inch, Modified
CR	• Sidewalk, Sidewalk Ramp, and Driveway Approach, Any Thickness, Rem • Dr Structure, Rem
DS	• Sewer, Rem, Less than 24 inch • Dr Structure, 24 inch dia • Dr Structure, Rem
DSDI	• Sewer, Rem, Less than 24 inch • Dr Structure, Double Inlet
PT	• Dr Structure, Point • Dr Structure Cover, Type B • Dr Structure Cover, Type B, Special • Dr Structure, Adj, Case 1, Modified • Dr Structure, Temp Lowering, Modified
RRK	• Dr Structure Cover, Type K • Dr Structure, Adj, Case 1, Modified
RS	• Dr Structure, Reconstruct
TYPE I	• Plastic Drum, High Intensity, Lighted, Furn • Plastic Drum, High Intensity, Lighted, Oper
TYPE II	• Barricade, Type III, High Intensity, Double Sided, Lighted, Furn • Barricade, Type III, High Intensity, Double Sided, Lighted, Oper

LEGEND	
SYMBOL	DESCRIPTION
⊙	EXISTING SANITARY SEWER MANHOLE
⊕	EXISTING STORM SEWER MANHOLE
⊗	EXISTING WATER MAIN VALVE IN WELL
+	WATER MAIN GATE VALVE IN BOX
⊕	FIRE HYDRANT
⊙	MICHCON GAS CO. VALVE BOX/WELL
⊕	AMERITECH TELEPHONE VAULT
⊙	ELECTRIC MANHOLE
⊕	SOIL BORING
□	EXISTING STORM SEWER INLET
⊕	MONUMENT BOX
▬	REMOVE AND REPLACE CONC. SIDEWALK
▬	PLACE CONCRETE SIDEWALK
▬	REMOVE & REPLACE CONC. CURB & GUTTER
---	CONSTRUCTION LIMITS
- - -	6" WRAPPED UNDERDRAIN
▨	REMOVE CONCRETE SIDEWALK
▬	SUBGRADE UNDERCUT

QUANTITIES				
Sign, Type B, Temp, Prismatic				
Quantity	Sign Code	Description	Area (sft)	Total
4.0	D3-1	Street Name Sign	4.000	16.000
1.0	R11-4	Road Closed Sign ("Road Closed To Thru Traffic")	12.500	12.500
2.0	W20-1	Road Work Ahead Sign	9.000	18.000
2.0	W20-3	Road Closed Ahead Sign	9.000	18.000
		TOTAL		64.500

CONSTRUCTION METHOD AND SEQUENCING

WORK ON THIS STREET INCLUDES, BUT IS NOT LIMITED TO, THE FOLLOWING ITEMS. COMPLETE THE WORK IN ACCORDANCE WITH THE PLANS AND SPECIFICATIONS, AND AS DIRECTED BY THE ENGINEER. PERFORM THE WORK IN THE ORDER INDICATED BELOW UNLESS OTHERWISE AUTHORIZED OR DIRECTED BY THE ENGINEER.

- IMPLEMENT MAINTENANCE OF TRAFFIC (M.O.T.) PLAN, AND INSTALL SOIL EROSION AND SEDIMENTATION CONTROL MEASURES.
- CONDUCT REMOVAL WORK RELATED TO PAVEMENT, DRAINAGE, AND CONCRETE ITEMS WITH EXCEPTION TO COLDMILLING.
- INSTALL PROPOSED DRAINAGE STRUCTURES, STORM SEWER, AND UNDERDRAIN AS REQUIRED.
- PERFORM ALL CONCRETE WORK, INCLUDING RESTORATION, AS REQUIRED.
- TEMPORARY LOWER ALL STRUCTURE COVERS LOCATED WITHIN THE EXISTING PAVEMENT, INCLUDING GATE AND MONUMENT BOXES AS REQUIRED.
- REMOVE 4.0 INCHES OF EXISTING HMA SURFACE BY COLDMILLING. THIS MAY INCLUDE GRANULAR BASE MATERIAL. DEPTH TO BE DETERMINED BY THE ENGINEER. PROOF ROLL WITH FULLY LOADED TRUCK.
- PERFORM ALL JOINT AND CRACK CLEANOUT, HMA/HAND PATCHING, UNDERCUTS AND/OR BASE REPAIRS AS REQUIRED.
- GRADE, SHAPE, AND COMPACT THE EXISTING BASE MATERIAL AS REQUIRED.
- CLEAN PAVEMENT AS REQUIRED, AND PLACE 2.0 INCH LEVELING COURSE HMA MIX (LOCAL STREETS).
- ADJUST ALL STRUCTURE COVERS, INCLUDING GATE AND MONUMENT BOXES, TO THEIR FINISHED ELEVATIONS AS REQUIRED.
- CLEAN PAVEMENT AND PLACE 2.0 INCH TOP COURSE HMA MIX (LOCAL STREETS).
- CLEAN PAVEMENT AND COMPLETE ALL PAVEMENT MARKINGS.
- COMPLETE ALL MISCELLANEOUS CONSTRUCTION INCLUDING ALL CLEAN UP AND FINAL RESTORATION.
- REMOVE ALL TRAFFIC CONTROL DEVICES, AND MISS DIG FLAGS.

NOTES

FOR PROTECTION OF UNDERGROUND UTILITIES AND IN CONFORMANCE WITH PUBLIC ACT 174 OF 2013, THE CONTRACTOR SHALL CALL 811 OR 1-800-482-7171 A MINIMUM OF THREE FULL WORKING DAYS, EXCLUDING SATURDAYS, SUNDAYS, AND HOLIDAYS, PRIOR TO BEGINNING EACH EXCAVATION IN AREAS WHERE PUBLIC UTILITIES HAVE NOT BEEN PREVIOUSLY LOCATED. MEMBERS WILL THUS BE ROUTINELY NOTIFIED. THIS DOES NOT RELIEVE THE CONTRACTOR OF THE RESPONSIBILITY OF NOTIFYING UTILITY OWNERS WHO MAY NOT BE A PART OF THE "MISS DIG" ALERT SYSTEM.

THE UNDERGROUND LOCATIONS SHOWN FOR NATURAL GAS, TELEPHONE, ELECTRICAL POWER, CABLE TV AND FIBER OPTIC LINES ARE APPROXIMATE. THE CITY OF ANN ARBOR ASSUMES NO RESPONSIBILITY FOR THEIR ACCURATE REPRESENTATION IN THIS DRAWING. MISS DIG MUST BE CONTACTED PRIOR TO CONSTRUCTION TO LOCATE THESE UTILITIES.

THE IMPROVEMENTS COVERED BY THESE PLANS SHALL BE PERFORMED IN ACCORDANCE WITH MICHIGAN DEPARTMENT OF TRANSPORTATION (MDOT) 2012 STANDARD SPECIFICATIONS FOR CONSTRUCTION, INCLUDING REFERENCED MDOT PUBLICATIONS, AND THE PROJECT CONTRACT DOCUMENTS.



PROJECT MANAGEMENT SERVICES UNIT
CITY OF ANN ARBOR PUBLIC SERVICES
301 EAST HURON STREET, P.O. BOX 8647
ANN ARBOR, MICHIGAN 48107-8647
734-794-6410 www.a2gov.org

PROJECT MANAGEMENT - PUBLIC SERVICES - CITY OF ANN ARBOR

STREET RESURFACING - 2016

BIRCH HOLLOW DRIVE

PROJECT DESCRIPTION

DRAWING No. 2016004-87

SHEET No. 87 OF 98

S:\Project Management\Drafting\autocad\2016004\Plan Production\2016004-Birch Hollow.dwg Dwg Created: 30-Nov-15 - _a2 standard bw.stb - Plot Date: 15-Mar-16

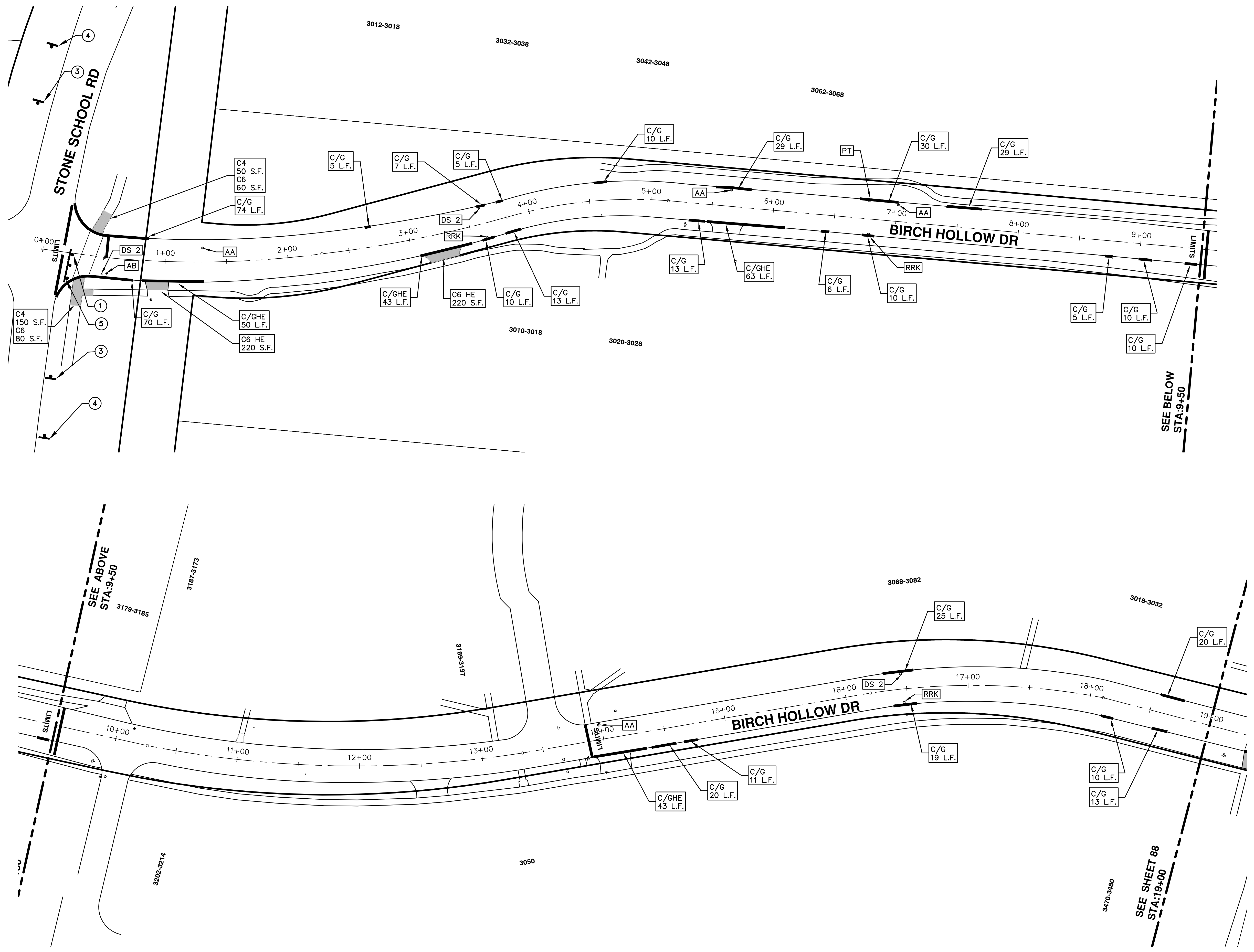

TRAFFIC CONTROL SIGN		
	SIGN	NUMBER
①	ROAD CLOSED TO THRU TRAFFIC	R11-4 60x30
②	ROAD CLOSED	R11-2 60x30
③	ROAD CLOSED AHEAD BIRCHHOLLOW	W20-3 36"x36" D3-1
④	ROAD WORK AHEAD BIRCHHOLLOW	W20-1 36"x36" D3-1
⑤	W/ TYPE III BARRICADE	

PROJECT MANAGEMENT - PUBLIC SERVICES - CITY OF ANN ARBOR
STREET RESURFACING - 2016
 BIRCH HOLLOW DRIVE
 RESURFACING

SCALE PLAN: 1" = 40'
 DRAWING No. 2016004-88
 SHEET No. 88 OF 98

811
 Know what's below.
 Call Before you dig.

CITY OF ANN ARBOR
 PUBLIC SERVICES
 301 EAST HURON STREET
 P.O. BOX 8647
 ANN ARBOR MI 48108-8647
 www.a2gov.org

CITY OF ANN ARBOR MICHIGAN

REV.	DESCRIPTION	DATE	DRAWN	CHECKED
02	ADDENDUM #3	3-15-2016	DAD	DAD
01	ADDENDUM #1	3-7-2016	DAD	DAD
00	BID SET	2-22-2016	GS AH JK	DAD

TRAFFIC CONTROL SIGN		
	SIGN	NUMBER
①		R11-4 60x30
②		R11-2 60x30
③		W20-3 36"x36"
		D3-1
④		W20-1 36"x36"
		D3-1
⑤	W/ TYPE III BARRICADE	

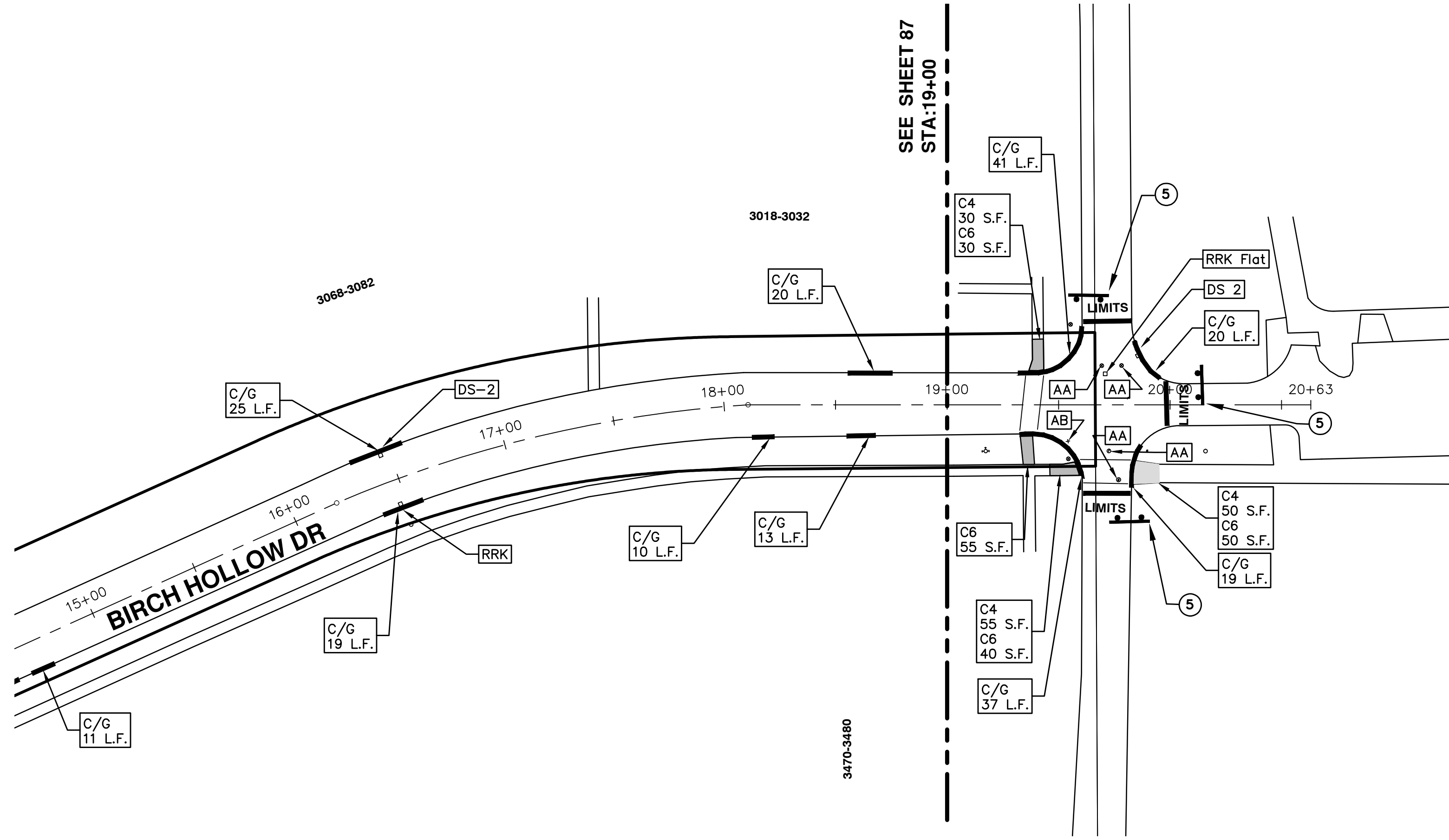



CITY OF ANN ARBOR PROJECT MANAGEMENT STREET RESURFACING - 2016 LOCATION: NORTH BAYLIS DRIVE

ITB No. 4422 FILE No. 2016004

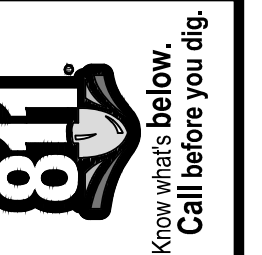

QUANTITIES			
Item Code	Item Description	Units	Quantity
2030011	Dr Structure, Rem	Ea	5.000
2030015	Sewer, Rem, Less than 24 inch	Ft	50.000
2047001	Curb, Gutter, and Curb and Gutter, Any Type, Rem	Ft	966.000
2047011	Sidewalk, Sidewalk Ramp, and Driveway Approach, Any Thickness, Rem	Syd	173.000
2057011	Grading, Driveway Approach	Syd	156.000
2057011	Grading, Sidewalk	Syd	18.000
2057011	Machine Grading, Special	Syd	3,945.000
2057021	Subgrade Undercutting, Type IIA	Cyd	351.000
2087050	Erosion Control, Inlet Filter	Ea	13.000
4020987	Sewer, CI IV, 12 inch, Tr Det B	Ft	50.000
4030200	Dr Structure, 24 inch dia	Ea	5.000
4037050	Dr Structure Cover, Type B, Modified	Ea	8.000
4037050	Dr Structure Cover, Type D, Modified	Ea	1.000
4030050	Dr Structure Cover, Type K, Modified	Ea	5.000
4037050	Dr Structure, Adj, Case 1, Modified	Ea	17.000
4037050	Dr Structure, Temp Lowering, Modified	Ea	12.000
5010003	Cold Milling HMA Surface	Ton	892.000
5010005	HMA Surface, Rem	Syd	110.000
5010703	HMA, LVSP	Ton	892.000
6027021	Flowable Fill	Cyd	35.778
6030005	Cement	Ton	10.000
8017011	Driveway, Nonreinf Conc, 6 inch, Modified	Syd	156.000
8027001	Curb and Gutter, Conc	Ft	450.000
8027001	Driveway Opening, Conc, Det M, Modified	Ft	540.000
8037010	Sidewalk, Conc, 6 inch, Modified	Sft	155.500
8110197	Pavt Mrkg, Thermopl, 6 inch, Crosswalk	Ft	290.000
8110218	Pavt Mrkg, Thermopl, 24 inch, Stop Bar	Ft	32.000
8120012	Barricade, Type III, High Intensity, Double Sided, Lighted, Furn	Ea	4.000
8120013	Barricade, Type III, High Intensity, Double Sided, Lighted, Oper	Ea	4.000
8120260	Plastic Drum, High Intensity, Lighted, Furn	Ea	50.000
8120261	Plastic Drum, High Intensity, Lighted, Oper	Ea	50.000
8120350	Sign, Type B, Temp, Prismatic, Furn	Sft	154.000
8120351	Sign, Type B, Temp, Prismatic, Oper	Sft	154.000
8127050	No Parking Sign	Ea	30.000
8167011	Slope Restoration	Syd	355.000
8230431	Gate Box, Adj, Case 1	Ea	1.000

CONSTRUCTION KEY	
KEY	ASSOCIATED PAY ITEM(S)
AA	• Dr Structure, Adj, Case 1, Modified • Dr Structure, Adj, Case 2, Modified • Dr Structure, Temp Lowering, Modified
AB	• Dr Structure, Temp Lowering, Modified • Gate Box, Adj, Case 1 • Gate Box, Adj, Case 2 • Monument Box Adjust
ADST	• Dr Structure, Adj, Add Depth, Modified
AK	• Dr Structure, Adj, Case 1, Modified
C4	• Sidewalk, Sidewalk Ramp, and Driveway Approach, Any Thickness, Rem • Grading, Sidewalk • Sidewalk, Conc, 4 inch, Modified
C4HE	• Sidewalk, Sidewalk Ramp, and Driveway Approach, Any Thickness, Rem • Grading, Sidewalk • Cement • Sidewalk, Conc, 4 inch, Modified
C6	• Sidewalk, Sidewalk Ramp, and Driveway Approach, Any Thickness, Rem • Grading, Sidewalk • Sidewalk Ramp • Detectable Warning Surface, Modified • Sidewalk Ramp, Conc, 6 inch, Modified • Sidewalk, Conc, 6 inch, Modified
C8	• Grading, Driveway Approach • Driveway, Nonreinf Conc, 8 inch, Modified • Sidewalk, Sidewalk Ramp, and Driveway Approach, Any Thickness, Rem • Grading, Driveway Approach • Grading, Sidewalk • Grading, Sidewalk Ramp
CHE	• Cement • Driveway, Nonreinf Conc, 6 inch, Modified • Driveway, Nonreinf Conc, 8 inch, Modified • Detectable Warning Surface, Modified • Sidewalk Ramp, Conc, 6 inch, Modified • Sidewalk, Conc, 6 inch, Modified
C/G	• Curb, Gutter, and Curb and Gutter, Any Type, Rem • Curb and Gutter, Conc
C/GHE	• Curb, Gutter, and Curb and Gutter, Any Type, Rem • Cement • Driveway Opening, Conc, Det M, Modified
CP	• Grading, Sidewalk • Sidewalk, Conc, 4 inch, Modified
CR	• Sidewalk, Sidewalk Ramp, and Driveway Approach, Any Thickness, Rem • Dr Structure, Rem
DS	• Sewer, Rem, Less than 24 inch • Dr Structure, 24 inch dia • Dr Structure, Rem
DSDI	• Sewer, Rem, Less than 24 inch • Dr Structure, Double Inlet
PT	• Dr Structure, Point • Dr Structure Cover, Type B • Dr Structure Cover, Type B, Special • Dr Structure, Adj, Case 1, Modified • Dr Structure, Temp Lowering, Modified
RRK	• Dr Structure Cover, Type K • Dr Structure, Adj, Case 1, Modified
RS	• Dr Structure, Reconstruct
TYPE II	• Plastic Drum, High Intensity, Lighted, Furn • Plastic Drum, High Intensity, Lighted, Oper
TYPE III	• Barricade, Type III, High Intensity, Double Sided, Lighted, Furn • Barricade, Type III, High Intensity, Double Sided, Lighted, Oper

LEGEND	
SYMBOL	DESCRIPTION
⊙	EXISTING SANITARY SEWER MANHOLE
⊕	EXISTING STORM SEWER MANHOLE
⊗	EXISTING WATER MAIN VALVE IN WELL
+	WATER MAIN GATE VALVE IN BOX
⊕+	FIRE HYDRANT
⊙	MICHCON GAS CO. VALVE BOX/WELL
Ⓢ	AMERITECH TELEPHONE VAULT
⊙	ELECTRIC MANHOLE
⊕	SOIL BORING
□	EXISTING STORM SEWER INLET
⊞	MONUMENT BOX
▬	REMOVE AND REPLACE CONC. SIDEWALK
▬	PLACE CONCRETE SIDEWALK
▬	REMOVE & REPLACE CONC. CURB & GUTTER
---	CONSTRUCTION LIMITS
---	6" WRAPPED UNDERDRAIN
▨	REMOVE CONCRETE SIDEWALK
▬	SUBGRADE UNDERCUT

CONSTRUCTION METHOD AND SEQUENCING

WORK ON THIS STREET INCLUDES, BUT IS NOT LIMITED TO, THE FOLLOWING ITEMS. COMPLETE THE WORK IN ACCORDANCE WITH THE PLANS AND SPECIFICATIONS, AND AS DIRECTED BY THE ENGINEER. PERFORM THE WORK IN THE ORDER INDICATED BELOW UNLESS OTHERWISE AUTHORIZED OR DIRECTED BY THE ENGINEER.

- IMPLEMENT MAINTENANCE OF TRAFFIC (M.O.T.) PLAN, AND INSTALL SOIL EROSION AND SEDIMENTATION CONTROL MEASURES.
- CONDUCT REMOVAL WORK RELATED TO PAVEMENT, DRAINAGE, AND CONCRETE ITEMS WITH EXCEPTION TO COLDMILLING.
- INSTALL PROPOSED DRAINAGE STRUCTURES, STORM SEWER, AND UNDERDRAIN AS REQUIRED.
- PERFORM ALL CONCRETE WORK, INCLUDING RESTORATION, AS REQUIRED.
- TEMPORARY LOWER ALL STRUCTURE COVERS LOCATED WITHIN THE EXISTING PAVEMENT, INCLUDING GATE AND MONUMENT BOXES AS REQUIRED.
- REMOVE 4.0 INCHES OF EXISTING HMA SURFACE BY COLDMILLING. THIS MAY INCLUDE GRANULAR BASE MATERIAL. DEPTH TO BE DETERMINED BY THE ENGINEER. PROOF ROLL WITH FULLY LOADED TRUCK.
- PERFORM ALL JOINT AND CRACK CLEANOUT, HMA/HAND PATCHING, UNDERCUTS AND/OR BASE REPAIRS AS REQUIRED.
- GRADE, SHAPE, AND COMPACT THE EXISTING BASE MATERIAL AS REQUIRED.
- CLEAN PAVEMENT AS REQUIRED, AND PLACE 2.0 INCH LEVELING COURSE HMA MIX (LOCAL STREETS).
- ADJUST ALL STRUCTURE COVERS, INCLUDING GATE AND MONUMENT BOXES, TO THEIR FINISHED ELEVATIONS AS REQUIRED.
- CLEAN PAVEMENT AND PLACE 2.0 INCH TOP COURSE HMA MIX (LOCAL STREETS).
- CLEAN PAVEMENT AND COMPLETE ALL PAVEMENT MARKINGS.
- COMPLETE ALL MISCELLANEOUS CONSTRUCTION INCLUDING ALL CLEAN UP AND FINAL RESTORATION.
- REMOVE ALL TRAFFIC CONTROL DEVICES, AND MISS DIG FLAGS.

QUANTITIES				
Sign, Type B, Temp, Prismatic				
Quantity	Sign Code	Description	Area (sft)	Total
8.0	D3-1	Street Name Sign	4.000	32.000
4.0	R11-4	Road Closed Sign ("Road Closed To Thru Traffic")	12.500	50.000
4.0	W20-1	Road Work Ahead Sign	9.000	36.000
4.0	W20-3	Road Closed Ahead Sign	9.000	36.000
		TOTAL		154.000

NOTES

FOR PROTECTION OF UNDERGROUND UTILITIES AND IN CONFORMANCE WITH PUBLIC ACT 174 OF 2013, THE CONTRACTOR SHALL CALL 811 OR 1-800-482-7171 A MINIMUM OF THREE FULL WORKING DAYS, EXCLUDING SATURDAYS, SUNDAYS, AND HOLIDAYS, PRIOR TO BEGINNING EACH EXCAVATION IN AREAS WHERE PUBLIC UTILITIES HAVE NOT BEEN PREVIOUSLY LOCATED. MEMBERS WILL THUS BE ROUTINELY NOTIFIED. THIS DOES NOT RELIEVE THE CONTRACTOR OF THE RESPONSIBILITY OF NOTIFYING UTILITY OWNERS WHO MAY NOT BE A PART OF THE "MISS DIG" ALERT SYSTEM.

THE UNDERGROUND LOCATIONS SHOWN FOR NATURAL GAS, TELEPHONE, ELECTRICAL POWER, CABLE TV AND FIBER OPTIC LINES ARE APPROXIMATE. THE CITY OF ANN ARBOR ASSUMES NO RESPONSIBILITY FOR THEIR ACCURATE REPRESENTATION IN THIS DRAWING. MISS DIG MUST BE CONTACTED PRIOR TO CONSTRUCTION TO LOCATE THESE UTILITIES.

THE IMPROVEMENTS COVERED BY THESE PLANS SHALL BE PERFORMED IN ACCORDANCE WITH MICHIGAN DEPARTMENT OF TRANSPORTATION (MDOT) 2012 STANDARD SPECIFICATIONS FOR CONSTRUCTION, INCLUDING REFERENCED MDOT PUBLICATIONS, AND THE PROJECT CONTRACT DOCUMENTS.



PROJECT MANAGEMENT SERVICES UNIT

CITY OF ANN ARBOR PUBLIC SERVICES
301 EAST HURON STREET, P.O. BOX 8647
ANN ARBOR, MICHIGAN 48107-8647
734-794-6410 www.a2gov.org

S:\Project Management\Drafting\autocad\2016004\Plan Production\2016004-N Baylis.dwg Dwg Created: 30-Nov-15 - a2 standard b.w.stb - Plot Date: 15-Mar-16

PROJECT MANAGEMENT - PUBLIC SERVICES - CITY OF ANN ARBOR

STREET RESURFACING - 2016

NORTH BAYLIS DRIVE

PROJECT DESCRIPTION

DRAWING No. 2016004-90

SHEET No.

90 OF 98



CITY OF ANN ARBOR PROJECT MANAGEMENT STREET RESURFACING - 2016

LOCATION: PEBBLE CREEK ROAD & CATALPA CIRCLE

ITB No. 4422 FILE No. 2016004

CONSTRUCTION METHOD AND SEQUENCING

WORK ON THIS STREET INCLUDES, BUT IS NOT LIMITED TO, THE FOLLOWING ITEMS. COMPLETE THE WORK IN ACCORDANCE WITH THE PLANS AND SPECIFICATIONS, AND AS DIRECTED BY THE ENGINEER. PERFORM THE WORK IN THE ORDER INDICATED BELOW UNLESS OTHERWISE AUTHORIZED OR DIRECTED BY THE ENGINEER.

1. IMPLEMENT MAINTENANCE OF TRAFFIC (M.O.T.) PLAN, AND INSTALL SOIL EROSION AND SEDIMENTATION CONTROL MEASURES.
2. CONDUCT REMOVAL WORK RELATED TO PAVEMENT, DRAINAGE, AND CONCRETE ITEMS WITH EXCEPTION TO COLDMILLING.
3. INSTALL PROPOSED DRAINAGE STRUCTURES, STORM SEWER, AND UNDERDRAIN AS REQUIRED.
4. PERFORM ALL CONCRETE WORK, INCLUDING RESTORATION, AS REQUIRED.
5. TEMPORARY LOWER ALL STRUCTURE COVERS LOCATED WITHIN THE EXISTING PAVEMENT, INCLUDING GATE AND MONUMENT BOXES AS REQUIRED.
6. REMOVE 4.0 INCHES OF EXISTING HMA SURFACE BY COLDMILLING. THIS MAY INCLUDE GRANULAR BASE MATERIAL. DEPTH TO BE DETERMINED BY THE ENGINEER. PROOF ROLL WITH FULLY LOADED TRUCK.
7. PERFORM ALL JOINT AND CRACK CLEANOUT, HMA/HAND PATCHING, UNDERCUTS AND/OR BASE REPAIRS AS REQUIRED.
8. GRADE, SHAPE, AND COMPACT THE EXISTING BASE MATERIAL AS REQUIRED.
9. CLEAN PAVEMENT AS REQUIRED, AND PLACE 2.0 INCH LEVELING COURSE HMA MIX (LOCAL STREETS).
10. ADJUST ALL STRUCTURE COVERS, INCLUDING GATE AND MONUMENT BOXES, TO THEIR FINISHED ELEVATIONS AS REQUIRED.
11. CLEAN PAVEMENT AND PLACE 2.0 INCH TOP COURSE HMA MIX (LOCAL STREETS).
12. CLEAN PAVEMENT AND COMPLETE ALL PAVEMENT MARKINGS.
13. COMPLETE ALL MISCELLANEOUS CONSTRUCTION INCLUDING ALL CLEAN UP AND FINAL RESTORATION.
14. REMOVE ALL TRAFFIC CONTROL DEVICES, AND MISS DIG FLAGS.

QUANTITIES			
Item Code	Item Description	Units	Quantity
2030011	Dr Structure, Rem	Ea	4.000
2030015	Sewer, Rem, Less than 24 inch	Ft	40.000
2047001	Curb, Gutter, and Curb and Gutter, Any Type, Rem	Ft	1,907.000
2047011	Sidewalk, Sidewalk Ramp, and Driveway Approach, Any Thickness, Rem	Syd	190.000
2057011	Grading, Driveway Approach	Syd	135.000
2057011	Grading, Sidewalk	Syd	33.000
2057011	Grading, Sidewalk Ramp	Syd	20.000
2057011	Machine Grading, Special	Syd	5,394.000
2057021	Subgrade Undercutting, Type IIA	Cyd	540.000
2087050	Erosion Control, Inlet Filter	Ea	17.000
4020987	Sewer, CI IV, 12 inch, Tr Det B	Ft	40.000
4030200	Dr Structure, 24 inch dia	Ea	4.000
4037050	Dr Structure Cover, Type B, Modified	Ea	21.000
4037050	Dr Structure Cover, Type D, Modified	Ea	1.000
4030050	Dr Structure Cover, Type K, Modified	Ea	6.000
4037050	Dr Structure, Adj, Case 1, Modified	Ea	24.000
4037050	Dr Structure, Temp Lowering, Modified	Ea	22.000
5010003	Cold Milling HMA Surface	Ton	1,219.000
5010005	HMA Surface, Rem	Syd	214.000
5010703	HMA, LVSP	Ton	1,219.000
6027021	Flowable Fill	Cyd	70.630
6030005	Cement	Ton	9.000
8017011	Driveway, Nonreinf Conc, 6 inch, Modified	Syd	135.000
8027001	Curb and Gutter, Conc	Ft	1,347.000
8027001	Driveway Opening, Conc, Det M, Modified	Ft	583.000
8037001	Detectable Warning Surface, Modified	Ft	40.000
8037010	Sidewalk Ramp, Conc, 6 inch, Modified	Sft	180.000
8037010	Sidewalk, Conc, 4 inch, Modified	Sft	160.000
8037010	Sidewalk, Conc, 6 inch, Modified	Sft	135.000
8110197	Pavt Mirkg, Thermopl, 6 inch, Crosswalk	Ft	302.000
8110218	Pavt Mirkg, Thermopl, 24 inch, Stop Bar	Ft	32.000
8120012	Barricade, Type III, High Intensity, Double Sided, Lighted, Furn	Ea	3.000
8120013	Barricade, Type III, High Intensity, Double Sided, Lighted, Oper	Ea	3.000
8120260	Plastic Drum, High Intensity, Lighted, Furn	Ea	68.000
8120261	Plastic Drum, High Intensity, Lighted, Oper	Ea	68.000
8120350	Sign, Type B, Temp, Prismatic, Furn	Sft	149.500
8120351	Sign, Type B, Temp, Prismatic, Oper	Sft	149.500
8127050	No Parking Sign	Ea	46.000
8167011	Slope Restoration	Syd	700.000

CONSTRUCTION KEY	
KEY	ASSOCIATED PAY ITEM(S)
AA	• Dr Structure, Adj, Case 1, Modified • Dr Structure, Adj, Case 2, Modified • Dr Structure, Temp Lowering, Modified
AB	• Dr Structure, Temp Lowering, Modified • Gate Box, Adj, Case 1 • Gate Box, Adj, Case 2 • Monument Box Adjust
ADST	• Dr Structure, Adj, Add Depth, Modified
AK	• Dr Structure, Adj, Case 1, Modified
C4	• Sidewalk, Sidewalk Ramp, and Driveway Approach, Any Thickness, Rem • Grading, Sidewalk • Sidewalk, Conc, 4 inch, Modified
C4HE	• Sidewalk, Sidewalk Ramp, and Driveway Approach, Any Thickness, Rem • Grading, Sidewalk • Cement • Sidewalk, Conc, 4 inch, Modified
C6	• Sidewalk, Sidewalk Ramp, and Driveway Approach, Any Thickness, Rem • Grading, Sidewalk • Detectable Warning Surface, Modified • Sidewalk Ramp, Conc, 6 inch, Modified • Sidewalk, Conc, 6 inch, Modified
C8	• Grading, Driveway Approach • Driveway, Nonreinf Conc, 8 inch, Modified • Sidewalk, Sidewalk Ramp, and Driveway Approach, Any Thickness, Rem • Grading, Driveway Approach • Grading, Sidewalk • Grading, Sidewalk Ramp • Cement • Driveway, Nonreinf Conc, 6 inch, Modified • Driveway, Nonreinf Conc, 8 inch, Modified • Detectable Warning Surface, Modified • Sidewalk Ramp, Conc, 6 inch, Modified • Sidewalk, Conc, 6 inch, Modified
C HE	• Grading, Driveway Approach • Curb, Gutter, and Curb and Gutter, Any Type, Rem • Curb and Gutter, Conc
C/G	• Curb, Gutter, and Curb and Gutter, Any Type, Rem • Curb and Gutter, Conc
C/GHE	• Cement • Driveway Opening, Conc, Det M, Modified
CP	• Grading, Sidewalk • Sidewalk, Conc, 4 inch, Modified
CR	• Sidewalk, Sidewalk Ramp, and Driveway Approach, Any Thickness, Rem • Dr Structure, Rem
DS	• Sewer, Rem, Less than 24 inch • Dr Structure, 24 inch dia • Dr Structure, Rem
DSDI	• Sewer, Rem, Less than 24 inch • Dr Structure, Double Inlet
PT	• Dr Structure, Point
RRA	• Dr Structure Cover, Type B • Dr Structure Cover, Type B, Special • Dr Structure, Adj, Case 1, Modified • Dr Structure, Temp Lowering, Modified
RRK	• Dr Structure Cover, Type K • Dr Structure, Adj, Case 1, Modified
RS	• Dr Structure, Reconstruct
TYPE II	• Plastic Drum, High Intensity, Lighted, Furn • Plastic Drum, High Intensity, Lighted, Oper
TYPE III	• Barricade, Type III, High Intensity, Double Sided, Lighted, Furn • Barricade, Type III, High Intensity, Double Sided, Lighted, Oper

LEGEND	
SYMBOL	DESCRIPTION
⊙	EXISTING SANITARY SEWER MANHOLE
⊙	EXISTING STORM SEWER MANHOLE
⊗	EXISTING WATER MAIN VALVE IN WELL
+	WATER MAIN GATE VALVE IN BOX
⊕	FIRE HYDRANT
⊙	MICHCON GAS CO. VALVE BOX/WELL
⊙	AMERITECH TELEPHONE VAULT
⊙	ELECTRIC MANHOLE
⊙	SOIL BORING
□	EXISTING STORM SEWER INLET
▣	MONUMENT BOX
▨	REMOVE AND REPLACE CONC. SIDEWALK
▨	PLACE CONCRETE SIDEWALK
▨	REMOVE & REPLACE CONC. CURB & GUTTER
---	CONSTRUCTION LIMITS
---	6" WRAPPED UNDERDRAIN
▨	REMOVE CONCRETE SIDEWALK
▨	SUBGRADE UNDERCUT

QUANTITIES				
Sign, Type B, Temp, Prismatic				
Quantity	Sign Code	Description	Area (sft)	Total
10.0	D3-1	Street Name Sign	4.000	40.000
3.0	R11-4	Road Closed Sign ("Road Closed To Thru Traffic")	12.500	37.500
4.0	W20-1	Road Work Ahead Sign	9.000	36.000
4.0	W20-3	Road Closed Ahead Sign	9.000	36.000
		TOTAL		149.500

NOTES:

FOR PROTECTION OF UNDERGROUND UTILITIES AND IN CONFORMANCE WITH PUBLIC ACT 174 OF 2013, THE CONTRACTOR SHALL CALL 811 OR 1-800-482-7171 A MINIMUM OF THREE FULL WORKING DAYS, EXCLUDING SATURDAYS, SUNDAYS, AND HOLIDAYS, PRIOR TO BEGINNING EACH EXCAVATION IN AREAS WHERE PUBLIC UTILITIES HAVE NOT BEEN PREVIOUSLY LOCATED. MEMBERS WILL THUS BE ROUTINELY NOTIFIED. THIS DOES NOT RELIEVE THE CONTRACTOR OF THE RESPONSIBILITY OF NOTIFYING UTILITY OWNERS WHO MAY NOT BE A PART OF THE "MISS DIG" ALERT SYSTEM.

THE UNDERGROUND LOCATIONS SHOWN FOR NATURAL GAS, TELEPHONE, ELECTRICAL POWER, CABLE TV AND FIBER OPTIC LINES ARE APPROXIMATE. THE CITY OF ANN ARBOR ASSUMES NO RESPONSIBILITY FOR THEIR ACCURATE REPRESENTATION IN THIS DRAWING. MISS DIG MUST BE CONTACTED PRIOR TO CONSTRUCTION TO LOCATE THESE UTILITIES.

THE IMPROVEMENTS COVERED BY THESE PLANS SHALL BE PERFORMED IN ACCORDANCE WITH MICHIGAN DEPARTMENT OF TRANSPORTATION (MDOT) 2012 STANDARD SPECIFICATIONS FOR CONSTRUCTION, INCLUDING REFERENCED MDOT PUBLICATIONS, AND THE PROJECT CONTRACT DOCUMENTS.



PROJECT MANAGEMENT SERVICES UNIT

CITY OF ANN ARBOR PUBLIC SERVICES
301 EAST HURON STREET, P.O. BOX 8647
ANN ARBOR, MICHIGAN 48107-8647
734-794-6410 www.a2gov.org



S:\Project Management\Drafting\autocad\2016004\Plan Production\2016004-PEBBLE CREEK RD.dwg Dwg Created: 30-Nov-15 - _a2 standard bw.stb - Plot Date: 15-Mar-16

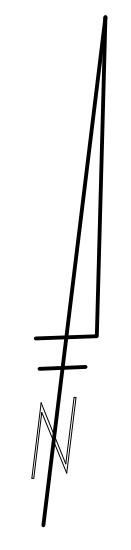
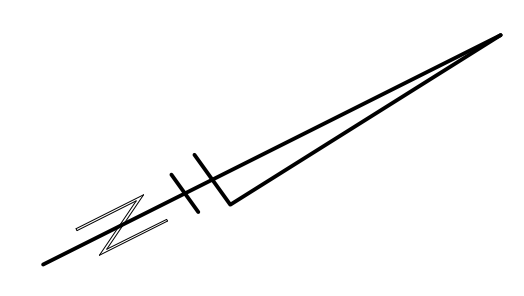
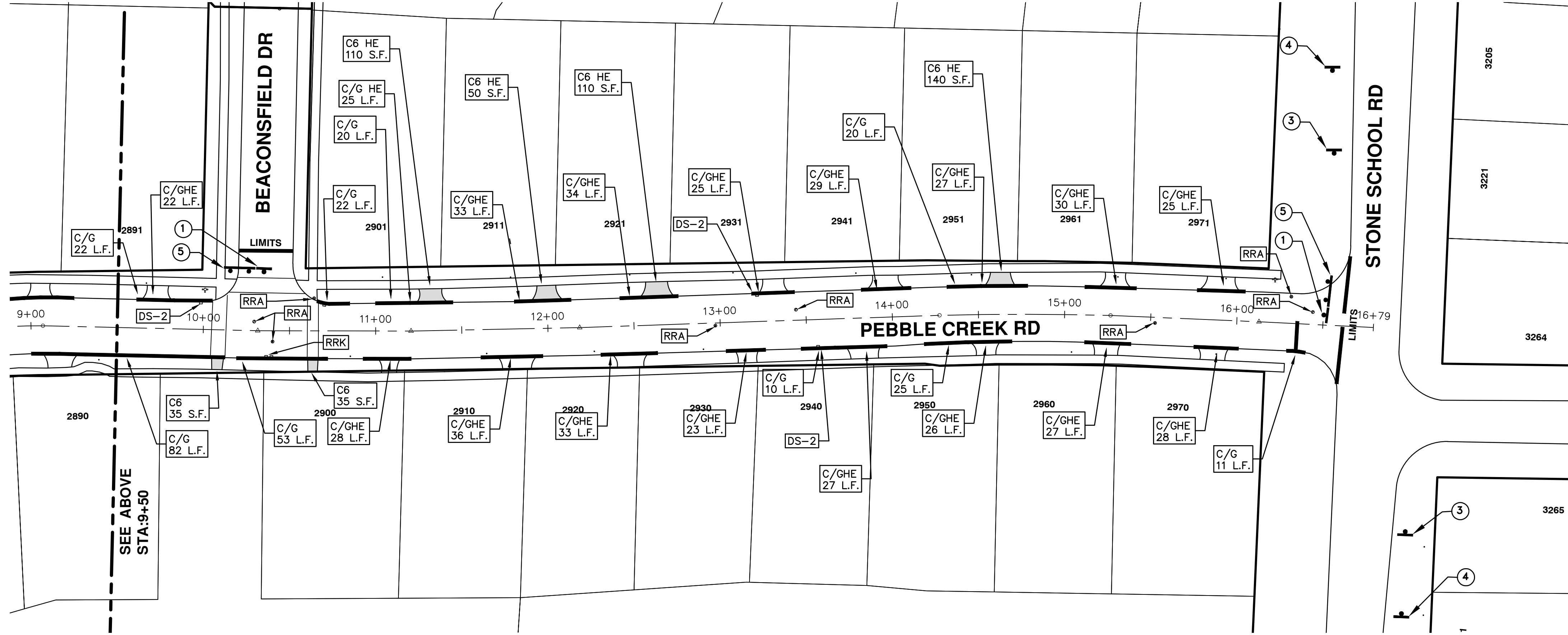
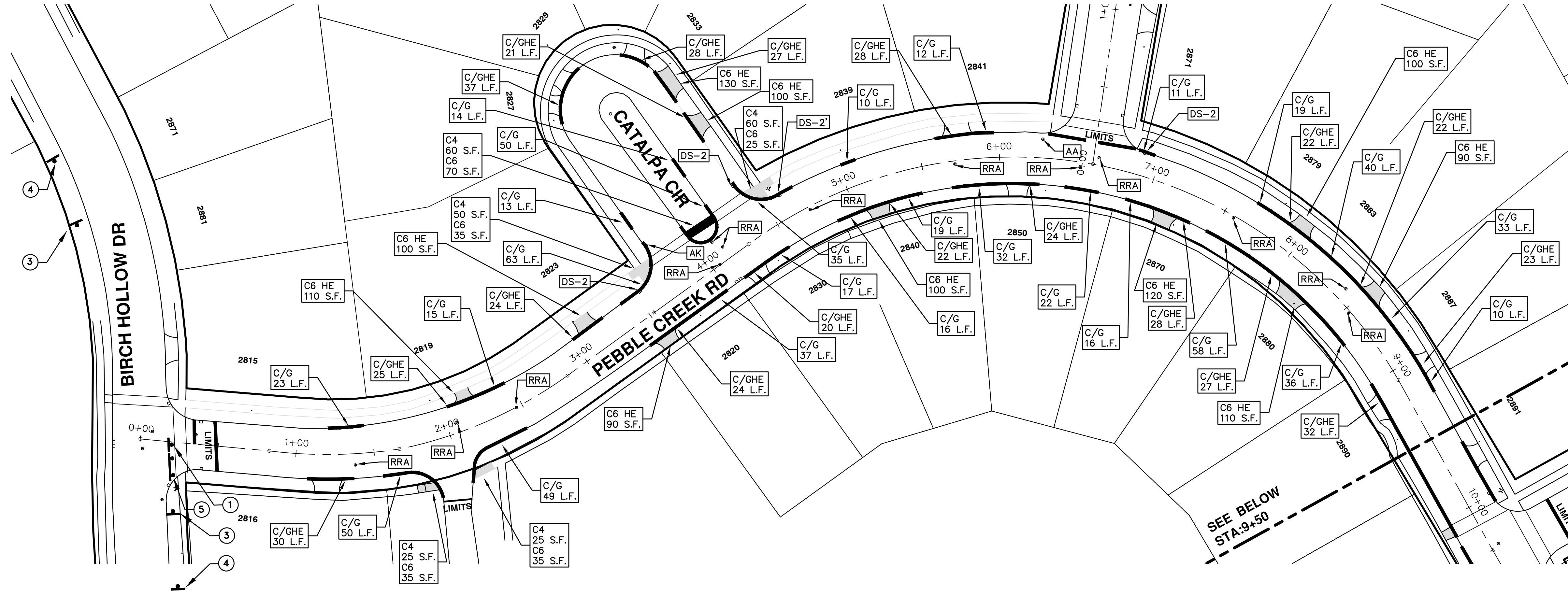

REV.	DATE	DESCRIPTION	DRAWN	CHECKED
02	3-15-2016	ADDENDUM #3	DAD	DAD
01	3-7-2016	ADDENDUM #1	DAD	DAD
00	2-22-2016	BID SET	GS AH UK	DAD

CITY OF ANN ARBOR
PUBLIC SERVICES
301 EAST HURON STREET
PO BOX 8647
ANN ARBOR MI 4810-8647
www.a2gov.org

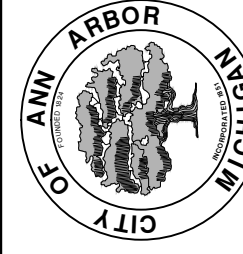

PROJECT MANAGEMENT - PUBLIC SERVICES - CITY OF ANN ARBOR
STREET RESURFACING - 2016
PEBBLE CREEK ROAD & CATALPA CIRCLE
RESURFACING

SCALE PLAN: 1" = 40'
DRAWING No. 2016004-93



CITY OF ANN ARBOR PROJECT MANAGEMENT STREET RESURFACING - 2016

LOCATION: BRENTWOOD & QUAIL HOLLOW & SUSSEX & WEXFORD COURTS

ITB No. 4422 FILE No. 2016004

QUANTITIES			
Item Code	Item Description	Units	Quantity
SUSSEX COURT			
2047001	_Curb, Gutter, and Curb and Gutter, Any Type, Rem	Ft	210.000
2057011	_Machine Grading, Special	Syd	1,122.000
2057021	_Subgrade Undercutting, Type IIA	Cyd	59.000
2087050	Erosion Control, Inlet Filter	Ea	4.000
4037050	_Dr Structure Cover, Type B, Modified	Ea	4.000
4037050	_Dr Structure Cover, Type K, Modified	Ea	2.000
4037050	_Dr Structure, Adj, Case 1, Modified	Ea	6.000
4037050	_Dr Structure, Temp Lowering, Modified	Ea	4.000
5010003	Cold Milling HMA Surface	Ton	254.000
5010005	HMA Surface, Rem	Syd	24.000
5010703	HMA, LVSP	Ton	254.000
6027021	Flowable Fill	Cyd	7.778
6030005	Cement	Ton	1.000
8027001	_Curb and Gutter, Conc	Ft	80.000
8027001	_Driveway Opening, Conc, Det M, Modified	Ft	134.000
8110197	Pav Mrg, Thermopl, 6 inch, Crosswalk	Ft	80.000
8120012	Barricade, Type III, High Intensity, Double Sided, Lighted, Furn	Ea	1.000
8120013	Barricade, Type III, High Intensity, Double Sided, Lighted, Oper	Ea	1.000
8120260	Plastic Drum, High Intensity, Lighted, Furn	Ea	10.000
8120261	Plastic Drum, High Intensity, Lighted, Oper	Ea	10.000
8127050	_No Parking Sign	Ea	5.000
8167011	_Slope Restoration	Syd	77.000
WEXFORD COURT			
2030011	Dr Structure, Rem	Ea	2.000
2030015	Sewer, Rem, Less than 24 inch	Ft	20.000
2047001	_Curb, Gutter, and Curb and Gutter, Any Type, Rem	Ft	654.000
2047011	_Sidewalk, Sidewalk Ramp, and Driveway Approach, Any Thickness, Rem	Syd	35.000
2057011	_Grading, Driveway Approach	Syd	31.000
2057011	_Grading, Sidewalk	Syd	4.000
2057011	_Machine Grading, Special	Syd	2,181.000
2057021	_Subgrade Undercutting, Type IIA	Cyd	148.000
2087050	Erosion Control, Inlet Filter	Ea	6.000
4020987	Sewer, CI IV, 12 inch, Tr Det B	Ft	20.000
4037050	_Dr Structure Cover, Special	Ea	1.000
4037050	_Dr Structure Cover, Type B, Modified	Ea	2.000
4037050	_Dr Structure Cover, Type K, Modified	Ea	4.000
4037050	_Dr Structure, Adj, Case 1, Modified	Ea	4.000
4037050	_Dr Structure, Double Inlet	Ea	2.000
4037050	_Dr Structure, Temp Lowering, Modified	Ea	5.000
5010003	Cold Milling HMA Surface	Ton	493.000
5010005	HMA Surface, Rem	Syd	75.000
5010703	HMA, LVSP	Ton	493.000
6027021	Flowable Fill	Cyd	24.222
6030005	Cement	Ton	3.000
8017011	_Driveway, Nonreinf Conc, 6 inch, Modified	Syd	31.000
8027001	_Curb and Gutter, Conc	Ft	375.000
8027001	_Driveway Opening, Conc, Det M, Modified	Ft	293.000
8037010	_Sidewalk, Conc, 6 inch, Modified	Sft	31.000
8110197	Pav Mrg, Thermopl, 6 inch, Crosswalk	Ft	73.000
8110218	Pav Mrg, Thermopl, 24 inch, Stop Bar	Ft	15.000
8120012	Barricade, Type III, High Intensity, Double Sided, Lighted, Furn	Ea	1.000
8120013	Barricade, Type III, High Intensity, Double Sided, Lighted, Oper	Ea	1.000
8120260	Plastic Drum, High Intensity, Lighted, Furn	Ea	20.000
8120261	Plastic Drum, High Intensity, Lighted, Oper	Ea	20.000
8120350	Sign, Type B, Temp, Prismatic, Furn	Sft	52.000
8120351	Sign, Type B, Temp, Prismatic, Oper	Sft	52.000
8127050	_No Parking Sign	Ea	13.000
8167011	_Slope Restoration	Syd	240.000
8230431	Gate Box, Adj, Case 1	Ea	1.000

QUANTITIES			
Item Code	Item Description	Units	Quantity
BRENTWOOD COURT			
2047001	_Curb, Gutter, and Curb and Gutter, Any Type, Rem	Ft	684.000
2047011	_Sidewalk, Sidewalk Ramp, and Driveway Approach, Any Thickness, Rem	Syd	79.000
2057011	_Grading, Driveway Approach	Syd	71.000
2057011	_Grading, Sidewalk	Syd	8.000
2057011	_Machine Grading, Special	Syd	2,444.000
2057021	_Subgrade Undercutting, Type IIA	Cyd	176.000
2087050	Erosion Control, Inlet Filter	Ea	7.000
4037050	_Dr Structure Cover, Type B, Modified	Ea	4.000
4037050	_Dr Structure Cover, Type K, Modified	Ea	4.000
4037050	_Dr Structure, Adj, Case 1, Modified	Ea	10.000
4037050	_Dr Structure, Temp Lowering, Modified	Ea	5.000
5010003	Cold Milling HMA Surface	Ton	553.000
5010005	HMA Surface, Rem	Syd	77.000
5010703	HMA, LVSP	Ton	553.000
6027021	Flowable Fill	Cyd	25.333
6030005	Cement	Ton	5.000
8017011	_Driveway, Nonreinf Conc, 6 inch, Modified	Syd	71.000
8027001	_Curb and Gutter, Conc	Ft	418.000
8027001	_Driveway Opening, Conc, Det M, Modified	Ft	272.000
8037010	_Sidewalk, Conc, 6 inch, Modified	Sft	70.500
8110197	Pav Mrg, Thermopl, 6 inch, Crosswalk	Ft	73.000
8110218	Pav Mrg, Thermopl, 24 inch, Stop Bar	Ft	15.000
8120012	Barricade, Type III, High Intensity, Double Sided, Lighted, Furn	Ea	1.000
8120013	Barricade, Type III, High Intensity, Double Sided, Lighted, Oper	Ea	1.000
8120260	Plastic Drum, High Intensity, Lighted, Furn	Ea	22.000
8120261	Plastic Drum, High Intensity, Lighted, Oper	Ea	22.000
8120350	Sign, Type B, Temp, Prismatic, Furn	Sft	52.000
8120351	Sign, Type B, Temp, Prismatic, Oper	Sft	52.000
8127050	_No Parking Sign	Ea	15.000
8167011	_Slope Restoration	Syd	251.000
QUAIL HOLLOW COURT			
2030011	Dr Structure, Rem	Ea	2.000
2030015	Sewer, Rem, Less than 24 inch	Ft	20.000
2047001	_Curb, Gutter, and Curb and Gutter, Any Type, Rem	Ft	225.000
2057011	_Machine Grading, Special	Syd	1,544.000
2057021	_Subgrade Undercutting, Type IIA	Cyd	73.000
2087050	Erosion Control, Inlet Filter	Ea	3.000
4020987	Sewer, CI IV, 12 inch, Tr Det B	Ft	20.000
4030200	Dr Structure, 24 inch dia	Ea	2.000
4037050	_Dr Structure Cover, Type B, Modified	Ea	1.000
4037050	_Dr Structure Cover, Type K, Modified	Ea	2.000
4037050	_Dr Structure, Adj, Case 1, Modified	Ea	4.000
4037050	_Dr Structure, Temp Lowering, Modified	Ea	2.000
5010003	Cold Milling HMA Surface	Ton	349.000
5010005	HMA Surface, Rem	Syd	27.000
5010703	HMA, LVSP	Ton	349.000
6027021	Flowable Fill	Cyd	8.333
6030005	Cement	Ton	1.000
8027001	_Curb and Gutter, Conc	Ft	134.000
8027001	_Driveway Opening, Conc, Det M, Modified	Ft	106.000
8120260	Plastic Drum, High Intensity, Lighted, Furn	Ea	10.000
8120261	Plastic Drum, High Intensity, Lighted, Oper	Ea	10.000
8127050	_No Parking Sign	Ea	6.000
8167011	_Slope Restoration	Syd	83.000

CONSTRUCTION KEY	
KEY	ASSOCIATED PAY ITEM(S)
AA	• _Dr Structure, Adj, Case 1, Modified • _Dr Structure, Adj, Case 2, Modified • _Dr Structure, Temp Lowering, Modified
AB	• _Dr Structure, Temp Lowering, Modified • _Gate Box, Adj, Case 1 • _Gate Box, Adj, Case 2 • _Monument Box Adjust
ADST	• _Dr Structure, Adj, Add Depth, Modified
AK	• _Dr Structure, Adj, Case 1, Modified
C4	• _Sidewalk, Sidewalk Ramp, and Driveway Approach, Any Thickness, Rem • _Grading, Sidewalk • _Sidewalk, Conc, 4 inch, Modified
C4HE	• _Sidewalk, Sidewalk Ramp, and Driveway Approach, Any Thickness, Rem • _Grading, Sidewalk • Cement • _Sidewalk, Conc, 4 inch, Modified
C6	• _Sidewalk, Sidewalk Ramp, and Driveway Approach, Any Thickness, Rem • _Grading, Sidewalk • _Detectable Warning Surface, Modified • _Sidewalk Ramp, Conc, 6 inch, Modified • _Sidewalk, Conc, 6 inch, Modified
C8	• _Grading, Driveway Approach • _Driveway, Nonreinf Conc, 8 inch, Modified • _Sidewalk, Sidewalk Ramp, and Driveway Approach, Any Thickness, Rem • _Grading, Driveway Approach • _Grading, Sidewalk • _Grading, Sidewalk Ramp • Cement
CHE	• _Driveway, Nonreinf Conc, 6 inch, Modified • _Driveway, Nonreinf Conc, 8 inch, Modified • _Detectable Warning Surface, Modified • _Sidewalk Ramp, Conc, 6 inch, Modified • _Sidewalk, Conc, 6 inch, Modified
C/G	• _Curb, Gutter, and Curb and Gutter, Any Type, Rem • _Curb and Gutter, Conc
C/GHE	• _Curb, Gutter, and Curb and Gutter, Any Type, Rem • Cement • _Driveway Opening, Conc, Det M, Modified
CP	• _Grading, Sidewalk • _Sidewalk, Conc, 4 inch, Modified
CR	• _Sidewalk, Sidewalk Ramp, and Driveway Approach, Any Thickness, Rem • _Dr Structure, Rem
DS	• Sewer, Rem, Less than 24 inch • Dr Structure, 24 inch dia • Dr Structure, Rem
DSDI	• Sewer, Rem, Less than 24 inch • _Dr Structure, Double Inlet • _Dr Structure, Point
PT	• _Dr Structure Cover, Type B • _Dr Structure Cover, Type B, Special • _Dr Structure, Adj, Case 1, Modified • _Dr Structure, Temp Lowering, Modified
RRA	• _Dr Structure Cover, Type K • _Dr Structure, Adj, Case 1, Modified
RRK	• _Dr Structure Cover, Type K • _Dr Structure, Adj, Case 1, Modified
RS	• _Dr Structure, Reconstruct
TYPE II	• Plastic Drum, High Intensity, Lighted, Furn • Plastic Drum, High Intensity, Lighted, Oper
TYPE III	• Barricade, Type III, High Intensity, Double Sided, Lighted, Furn • Barricade, Type III, High Intensity, Double Sided, Lighted, Oper

CONSTRUCTION METHOD AND SEQUENCING

WORK ON THESE STREETS INCLUDES, BUT IS NOT LIMITED TO, THE FOLLOWING ITEMS. COMPLETE THE WORK IN ACCORDANCE WITH THE PLANS AND SPECIFICATIONS, AND AS DIRECTED BY THE ENGINEER. PERFORM THE WORK IN THE ORDER INDICATED BELOW UNLESS OTHERWISE AUTHORIZED OR DIRECTED BY THE ENGINEER.

- IMPLEMENT MAINTENANCE OF TRAFFIC (M.O.T.) PLAN, AND INSTALL SOIL EROSION AND SEDIMENTATION CONTROL MEASURES.
- CONDUCT REMOVAL WORK RELATED TO PAVEMENT, DRAINAGE, AND CONCRETE ITEMS WITH EXCEPTION TO COLDMILLING.
- INSTALL PROPOSED DRAINAGE STRUCTURES, STORM SEWER, AND UNDERDRAIN AS REQUIRED.
- PERFORM ALL CONCRETE WORK, INCLUDING RESTORATION, AS REQUIRED.
- TEMPORARY LOWER ALL STRUCTURE COVERS LOCATED WITHIN THE EXISTING PAVEMENT, INCLUDING GATE AND MONUMENT BOXES AS REQUIRED.
- REMOVE 4.0 INCHES OF EXISTING HMA SURFACE BY COLDMILLING. THIS MAY INCLUDE GRANULAR BASE MATERIAL. DEPTH TO BE DETERMINED BY THE ENGINEER. PROOF ROLL WITH FULLY LOADED TRUCK.
- PERFORM ALL JOINT AND CRACK CLEANOUT, HMA/HAND PATCHING, UNDERCUTS AND/OR BASE REPAIRS AS REQUIRED.
- GRADE, SHAPE, AND COMPACT THE EXISTING BASE MATERIAL AS REQUIRED.
- CLEAN PAVEMENT AS REQUIRED, AND PLACE 2.0 INCH LEVELING COURSE HMA MIX (LOCAL STREETS).
- ADJUST ALL STRUCTURE COVERS, INCLUDING GATE AND MONUMENT BOXES, TO THEIR FINISHED ELEVATIONS AS REQUIRED.
- CLEAN PAVEMENT AND PLACE 2.0 INCH TOP COURSE HMA MIX (LOCAL STREETS).
- CLEAN PAVEMENT AND COMPLETE ALL PAVEMENT MARKINGS.
- COMPLETE ALL MISCELLANEOUS CONSTRUCTION INCLUDING ALL CLEAN UP AND FINAL RESTORATION.
- REMOVE ALL TRAFFIC CONTROL DEVICES, AND MISS DIG FLAGS.

NOTES

FOR PROTECTION OF UNDERGROUND UTILITIES AND IN CONFORMANCE WITH PUBLIC ACT 174 OF 2013, THE CONTRACTOR SHALL CALL 811 OR 1-800-482-7171 A MINIMUM OF THREE FULL WORKING DAYS, EXCLUDING SATURDAYS, SUNDAYS, AND HOLIDAYS, PRIOR TO BEGINNING EACH EXCAVATION IN AREAS WHERE PUBLIC UTILITIES HAVE NOT BEEN PREVIOUSLY LOCATED. MEMBERS WILL THUS BE ROUTINELY NOTIFIED. THIS DOES NOT RELIEVE THE CONTRACTOR OF THE RESPONSIBILITY OF NOTIFYING UTILITY OWNERS WHO MAY NOT BE A PART OF THE "MISS DIG" ALERT SYSTEM.

THE UNDERGROUND LOCATIONS SHOWN FOR NATURAL GAS, TELEPHONE, ELECTRICAL POWER, CABLE TV AND FIBER OPTIC LINES ARE APPROXIMATE. THE CITY OF ANN ARBOR ASSUMES NO RESPONSIBILITY FOR THEIR ACCURATE REPRESENTATION IN THIS DRAWING. MISS DIG MUST BE CONTACTED PRIOR TO CONSTRUCTION TO LOCATE THESE UTILITIES.

THE IMPROVEMENTS COVERED BY THESE PLANS SHALL BE PERFORMED IN ACCORDANCE WITH MICHIGAN DEPARTMENT OF TRANSPORTATION (MDOT) 2012 STANDARD SPECIFICATIONS FOR CONSTRUCTION, INCLUDING REFERENCED MDOT PUBLICATIONS, AND THE PROJECT CONTRACT DOCUMENTS.

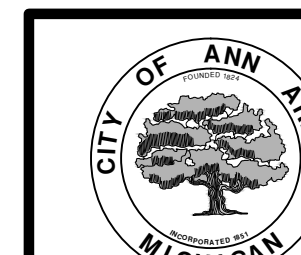

PROJECT MANAGEMENT SERVICES UNIT

CITY OF ANN ARBOR PUBLIC SERVICES
301 EAST HURON STREET, P.O. BOX 8647
ANN ARBOR, MICHIGAN 48107-8647
734-794-6410 www.a2gov.org

PROJECT MANAGEMENT - PUBLIC SERVICES - CITY OF ANN ARBOR
STREET RESURFACING - 2016

BRENTWOOD & QUAIL HOLLOW & SUSSEX &
WEXFORD COURTS

DRAWING No.
2016004-94

SHEET No.
94 OF 98



S:\Project Management\Drafting\autocad\2016004\Plan Production\2016004-Misc Courts.dwg Dwg Created: 30-Nov-15 - a2_standard bw.stb - Plot Date: 15-Mar-16

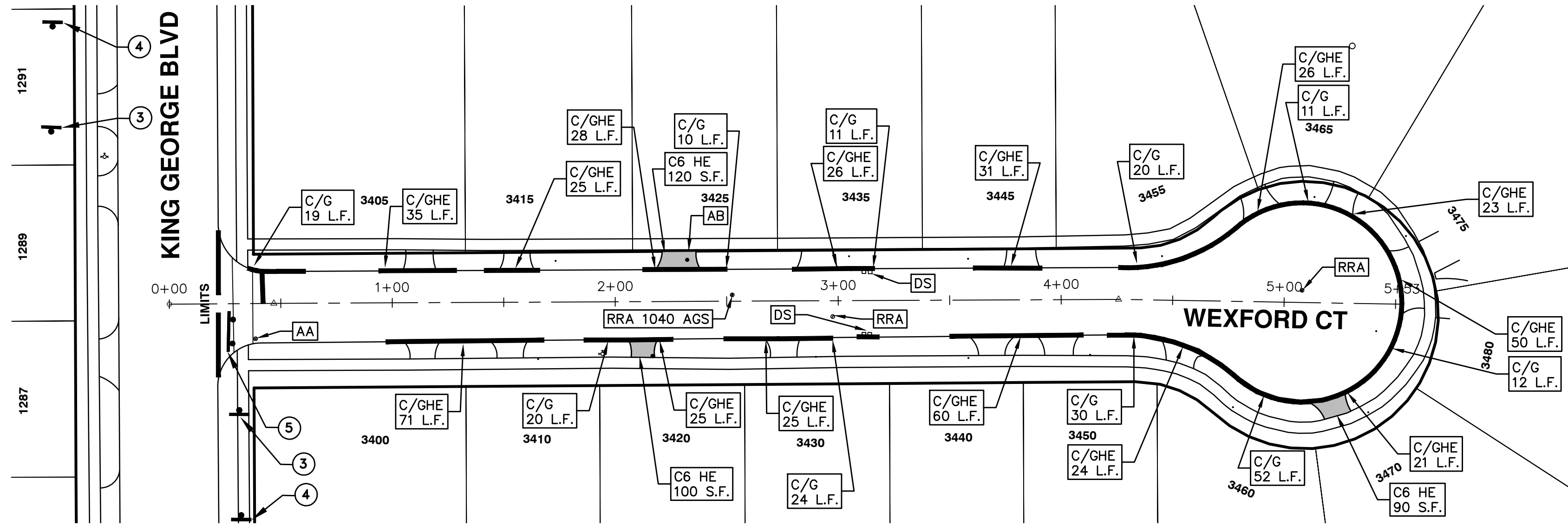
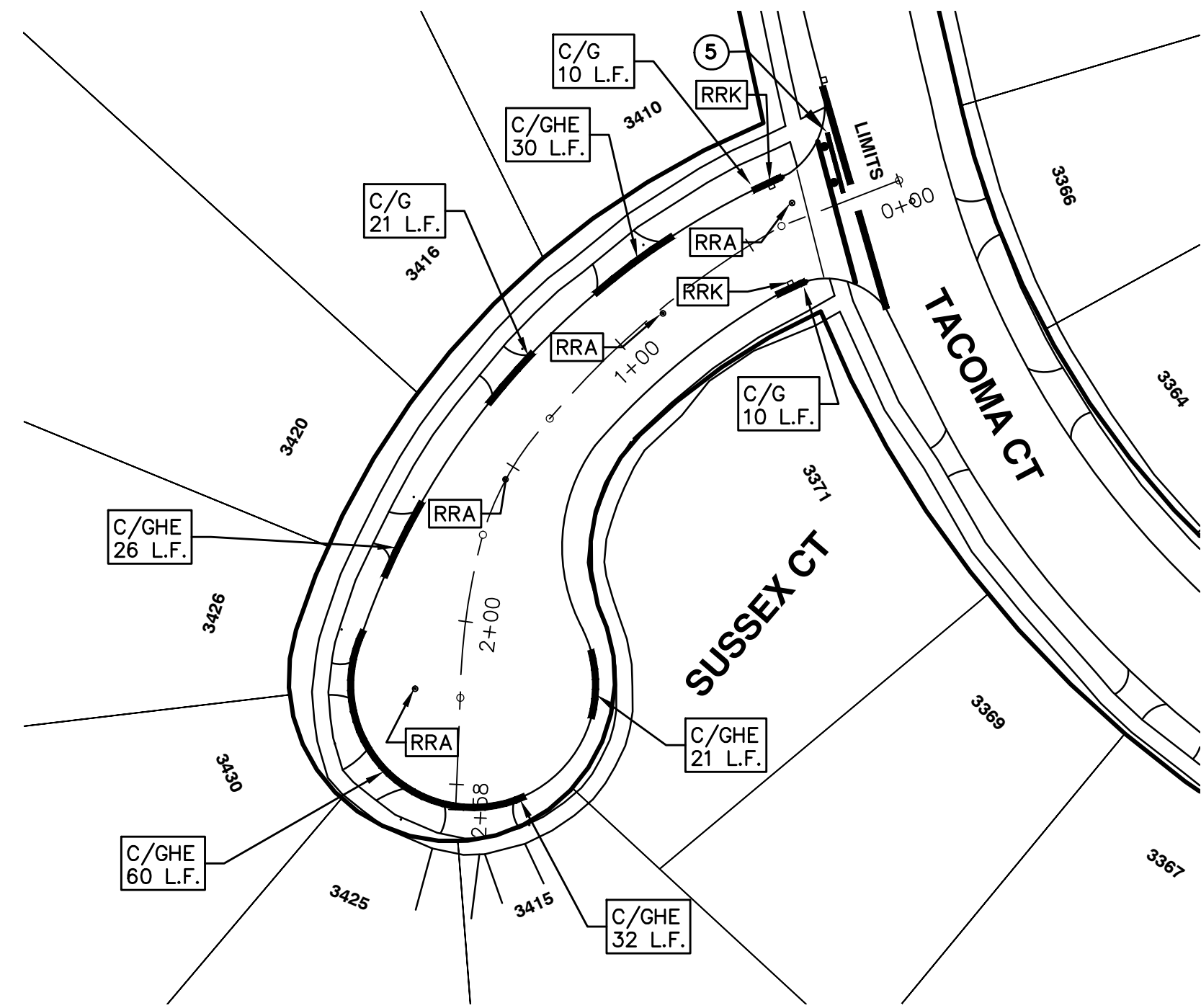

BRENTWOOD & WEXFORD COURTS

QUANTITIES				
Sign, Type B, Temp. Prismatic				
Quantity	Sign Code	Description	Area (sqft)	Total
4.0	D3-1	Street Name Sign	4,000	16,000
2.0	W20-1	Road Work Ahead Sign	9,000	18,000
2.0	W20-3	Road Closed Ahead Sign	9,000	18,000
		TOTAL		52,000

TRAFFIC CONTROL SIGN		
	SIGN	NUMBER
①	ROAD CLOSED TO THRU TRAFFIC	R11-4 60x30
③	ROAD CLOSED AHEAD	W20-3 36"x36"
	STREET	D3-1
④	ROAD WORK AHEAD	W20-1 36"x36"
	STREET	D3-1
⑤	W/ TYPE III BARRICADE	

LEGEND	
SYMBOL	DESCRIPTION
⊕	EXISTING SANITARY SEWER MANHOLE
⊕	EXISTING STORM SEWER MANHOLE
⊕	EXISTING WATER MAIN VALVE IN WELL
+	WATER MAIN GATE VALVE IN BOX
⊕	FIRE HYDRANT
⊕	MICHCON GAS CO. VALVE BOX/WELL
⊕	AMERITECH TELEPHONE VAULT
⊕	ELECTRIC MANHOLE
⊕	SOIL BORING
⊕	EXISTING STORM SEWER INLET
⊕	MONUMENT BOX
⊕	REMOVE AND REPLACE CONC. SIDEWALK
⊕	PLACE CONCRETE SIDEWALK
⊕	REMOVE & REPLACE CONC. CURB & GUTTER
⊕	CONSTRUCTION LIMITS
⊕	6" WRAPPED UNDERDRAIN
⊕	REMOVE CONCRETE SIDEWALK
⊕	SUBGRADE UNDERCUT

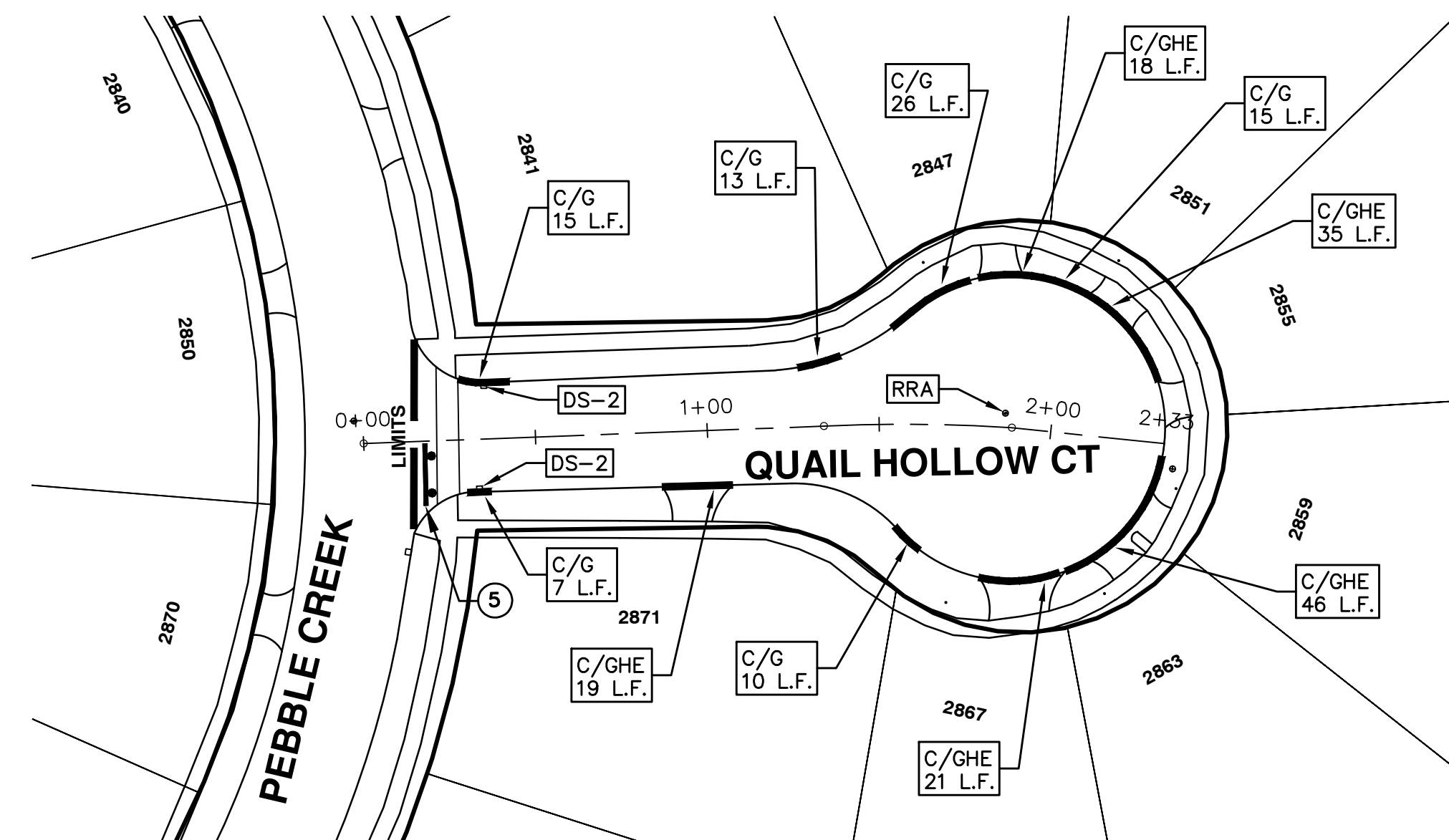
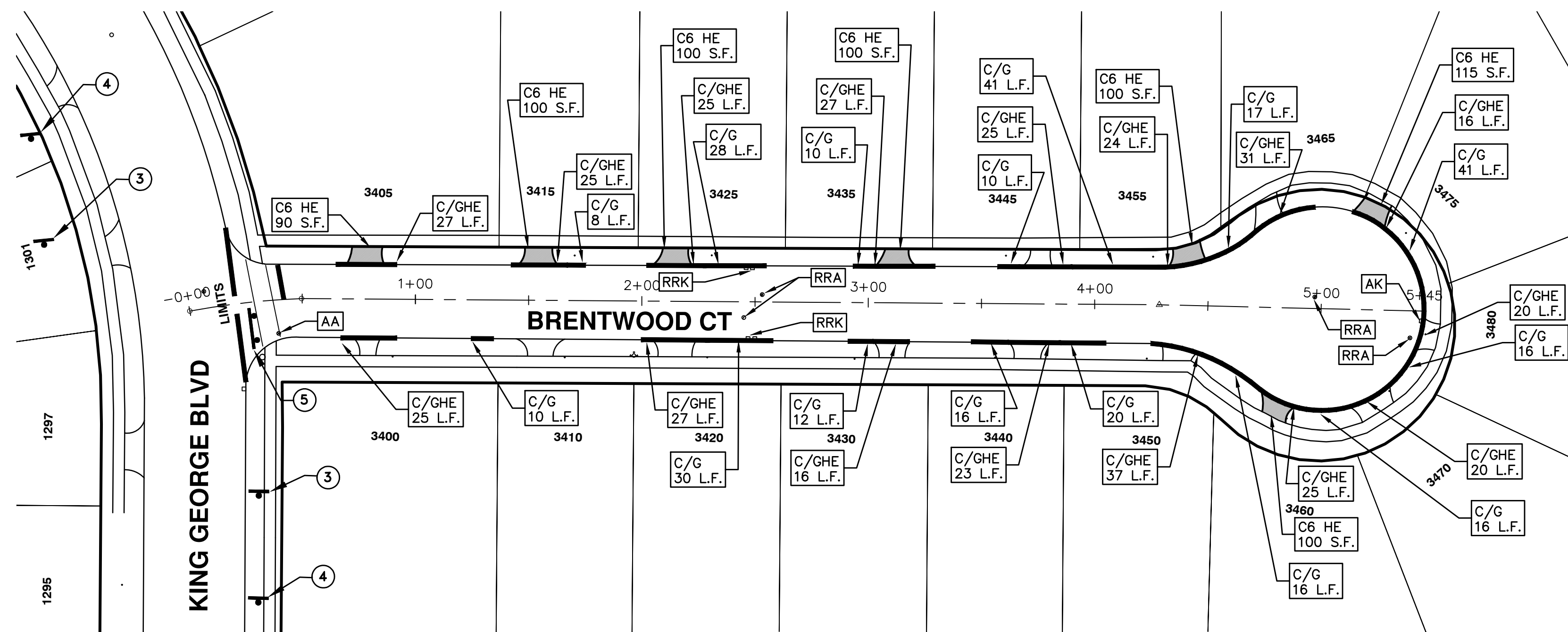

811
Know what's below.
Call before you dig.

02 ADDENDUM #3 3-15-2016
01 ADDENDUM #1 3-7-2016
00 BID SET 2-22-2016

REV. DATE DRAWN CHECKED

CITY OF ANN ARBOR
PUBLIC SERVICES
301 EAST HURON STREET
PO BOX 8640
ANN ARBOR MI 48108-8647
www.a2gov.org

PROJECT MANAGEMENT - PUBLIC SERVICES - CITY OF ANN ARBOR
STREET RESURFACING - 2016
BRENTWOOD & QUAIL HOLLOW & SUSSEX & WEXFORD COURTS
RESURFACING

SCALE 1" = 40'
DRAWING No. 2016004-95
SHEET No. 95 OF 98



CITY OF ANN ARBOR PROJECT MANAGEMENT STREET RESURFACING - 2016

LOCATION: BEACONSFIELD DRIVE & PAGE AVENUE &

TICKNOR COURT

ITB No. 4422 FILE No. 2016004

QUANTITIES			
Item Code	Item Description	Units	Quantity
BEACONSFIELD DRIVE			
2030011	Dr Structure, Rem	Ea	1.000
2030015	Sewer, Rem, Less than 24 inch	Ft	10.000
2047001	Curb, Gutter, and Curb and Gutter, Any Type, Rem	Ft	130.000
2047011	Sidewalk, Sidewalk Ramp, and Driveway Approach, Any Thickness, Rem	Syd	12.000
2057011	Grading, Driveway Approach	Syd	10.000
2057011	Grading, Sidewalk	Syd	2.000
2057011	Machine Grading, Special	Syd	1,051.000
2057021	Subgrade Undercutting, Type IIA	Cyd	106.000
2087050	Erosion Control, Inlet Filter	Ea	4.000
4020987	Sewer, CI IV, 12 inch, Tr Det B	Ft	10.000
4030200	Dr Structure, 24 inch dia	Ea	1.000
4037050	Dr Structure Cover, Type B, Modified	Ea	1.000
4037050	Dr Structure Cover, Type K, Modified	Ea	1.000
4037050	Dr Structure, Adj, Case 1, Modified	Ea	3.000
4037050	Dr Structure, Temp Lowering, Modified	Ea	2.000
5010003	Cold Milling HMA Surface	Ton	238.000
5010005	HMA Surface, Rem	Syd	15.000
5010703	HMA, LVSP	Ton	238.000
6027021	Flowable Fill	Cyd	4.815
6030005	Cement	Ton	1.000
8017011	Driveway, Nonreinf Conc, 6 inch, Modified	Syd	10.000
8027001	Curb and Gutter, Conc	Ft	113.000
8027001	Driveway Opening, Conc, Det M, Modified	Ft	19.000
8037010	Sidewalk, Conc, 6 inch, Modified	Sft	10.000
8110197	Pav Mrkg, Thermopl, 6 inch, Crosswalk	Ft	150.000
8120012	Barricade, Type III, High Intensity, Double Sided, Lighted, Fum	Ea	2.000
8120013	Barricade, Type III, High Intensity, Double Sided, Lighted, Oper	Ea	2.000
8120260	Plastic Drum, High Intensity, Lighted, Fum	Ea	13.000
8120261	Plastic Drum, High Intensity, Lighted, Oper	Ea	13.000
8120350	Sign, Type B, Temp, Prismatic, Fum	Sft	129.000
8120351	Sign, Type B, Temp, Prismatic, Oper	Sft	129.000
8127050	No Parking Sign	Ea	9.000
8167011	Slope Restoration	Syd	48.000
PAGE AVENUE			
2030011	Dr Structure, Rem	Ea	1.000
2030015	Sewer, Rem, Less than 24 inch	Ft	10.000
2047001	Curb, Gutter, and Curb and Gutter, Any Type, Rem	Ft	430.000
2047011	Sidewalk, Sidewalk Ramp, and Driveway Approach, Any Thickness, Rem	Syd	29.000
2057011	Grading, Driveway Approach	Syd	26.000
2057011	Grading, Sidewalk	Syd	3.000
2057011	Machine Grading, Special	Syd	1,808.000
2057021	Subgrade Undercutting, Type IIA	Cyd	149.000
2087050	Erosion Control, Inlet Filter	Ea	5.000
4020987	Sewer, CI IV, 12 inch, Tr Det B	Ft	10.000
4030200	Dr Structure, 24 inch dia	Ea	1.000
4037050	Dr Structure Cover, Type B, Modified	Ea	5.000
4037050	Dr Structure Cover, Type D, Modified	Ea	1.000
4030050	Dr Structure Cover, Type K, Modified	Ea	2.000
4037050	Dr Structure, Adj, Case 1, Modified	Ea	9.000
4037050	Dr Structure, Temp Lowering, Modified	Ea	6.000
5010003	Cold Milling HMA Surface	Ton	409.000
5010005	HMA Surface, Rem	Syd	46.000
5010703	HMA, LVSP	Ton	409.000
6027021	Flowable Fill	Cyd	15.926
6030005	Cement	Ton	2.000
8017011	Driveway, Nonreinf Conc, 6 inch, Modified	Syd	26.000
8027001	Curb and Gutter, Conc	Ft	197.000
8027001	Driveway Opening, Conc, Det M, Modified	Ft	224.000
8037010	Sidewalk, Conc, 6 inch, Modified	Sft	26.000
8110197	Pav Mrkg, Thermopl, 6 inch, Crosswalk	Ft	72.000
8110218	Pav Mrkg, Thermopl, 24 inch, Stop Bar	Ft	15.000
8120012	Barricade, Type III, High Intensity, Double Sided, Lighted, Fum	Ea	1.000
8120013	Barricade, Type III, High Intensity, Double Sided, Lighted, Oper	Ea	1.000
8120260	Plastic Drum, High Intensity, Lighted, Fum	Ea	20.000
8120261	Plastic Drum, High Intensity, Lighted, Oper	Ea	20.000
8120350	Sign, Type B, Temp, Prismatic, Fum	Sft	52.000
8120351	Sign, Type B, Temp, Prismatic, Oper	Sft	52.000
8127050	No Parking Sign	Ea	13.000
8167011	Slope Restoration	Syd	158.000

QUANTITIES			
Item Code	Item Description	Units	Quantity
TICKNOR COURT			
2030011	Dr Structure, Rem	Ea	4.000
2030015	Sewer, Rem, Less than 24 inch	Ft	40.000
2047001	Curb, Gutter, and Curb and Gutter, Any Type, Rem	Ft	988.000
2047011	Sidewalk, Sidewalk Ramp, and Driveway Approach, Any Thickness, Rem	Syd	230.000
2057011	Grading, Driveway Approach	Syd	175.000
2057011	Grading, Sidewalk	Syd	42.000
2057011	Grading, Sidewalk Ramp	Syd	187.000
2057011	Machine Grading, Special	Syd	2,794.000
2057021	Subgrade Undercutting, Type IIA	Cyd	209.000
2087050	Erosion Control, Inlet Filter	Ea	8.000
4020987	Sewer, CI IV, 12 inch, Tr Det B	Ft	40.000
4037050	Dr Structure Cover, Type B, Modified	Ea	7.000
4037050	Dr Structure Cover, Type K, Modified	Ea	8.000
4037050	Dr Structure, Adj, Case 1, Modified	Ea	7.000
4037050	Dr Structure, Double Inlet	Ea	4.000
4037050	Dr Structure, Temp Lowering, Modified	Ea	8.000
5010003	Cold Milling HMA Surface	Ton	632.000
5010005	HMA Surface, Rem	Syd	112.000
5010703	HMA, LVSP	Ton	632.000
6027021	Flowable Fill	Cyd	36.593
6030005	Cement	Ton	11.000
8017011	Driveway, Nonreinf Conc, 6 inch, Modified	Syd	175.000
8027001	Curb and Gutter, Conc	Ft	558.000
8027001	Driveway Opening, Conc, Det M, Modified	Ft	452.000
8037001	Detectable Warning Surface, Modified	Ft	10.000
8037010	Sidewalk Ramp, Conc, 6 inch, Modified	Sft	1,679.000
8037010	Sidewalk, Conc, 4 inch, Modified	Sft	200.000
8037010	Sidewalk, Conc, 6 inch, Modified	Sft	175.000
8110197	Pav Mrkg, Thermopl, 6 inch, Crosswalk	Ft	61.000
8110218	Pav Mrkg, Thermopl, 24 inch, Stop Bar	Ft	15.000
8120012	Barricade, Type III, High Intensity, Double Sided, Lighted, Fum	Ea	1.000
8120013	Barricade, Type III, High Intensity, Double Sided, Lighted, Oper	Ea	1.000
8120260	Plastic Drum, High Intensity, Lighted, Fum	Ea	32.000
8120261	Plastic Drum, High Intensity, Lighted, Oper	Ea	32.000
8120350	Sign, Type B, Temp, Prismatic, Fum	Sft	52.000
8120351	Sign, Type B, Temp, Prismatic, Oper	Sft	52.000
8127050	No Parking Sign	Ea	19.000
8167011	Slope Restoration	Syd	363.000
8230431	Gate Box, Adj, Case 1	Ea	1.000

QUANTITIES			
Sign, Type B, Temp, Prismatic			
BEACONSFIELD DRIVE			
8.0	D3-1	Street Name Sign	4.000
2.0	R11-4	Road Closed Sign ("Road Closed To Thru Traffic")	12.500
4.0	W20-1	Road Work Ahead Sign	9.000
4.0	W20-3	Road Closed Ahead Sign	9.000
TOTAL			129.000
PAGE AVENUE & TICKNOR COURT			
4.0	D3-1	Street Name Sign	4.000
2.0	W20-1	Road Work Ahead Sign	9.000
2.0	W20-3	Road Closed Ahead Sign	9.000
TOTAL			52.000

CONSTRUCTION KEY	
KEY	ASSOCIATED PAY ITEM(S)
AA	• Dr Structure, Adj, Case 1, Modified • Dr Structure, Adj, Case 2, Modified • Dr Structure, Temp Lowering, Modified
AB	• Dr Structure, Temp Lowering, Modified • Gate Box, Adj, Case 1 • Gate Box, Adj, Case 2 • Monument Box Adjust
ADST	• Dr Structure, Adj, Add Depth, Modified
AK	• Dr Structure, Adj, Case 1, Modified
C4	• Sidewalk, Sidewalk Ramp, and Driveway Approach, Any Thickness, Rem • Grading, Sidewalk • Sidewalk, Conc, 4 inch, Modified
C4HE	• Sidewalk, Sidewalk Ramp, and Driveway Approach, Any Thickness, Rem • Grading, Sidewalk • Cement • Sidewalk, Conc, 4 inch, Modified
C6	• Sidewalk, Sidewalk Ramp, and Driveway Approach, Any Thickness, Rem • Grading, Sidewalk • Grading, Sidewalk Ramp • Detectable Warning Surface, Modified • Sidewalk Ramp, Conc, 6 inch, Modified • Sidewalk, Conc, 6 inch, Modified
C8	• Grading, Driveway Approach • Driveway, Nonreinf Conc, 8 inch, Modified • Sidewalk, Sidewalk Ramp, and Driveway Approach, Any Thickness, Rem • Grading, Driveway Approach • Grading, Sidewalk • Grading, Sidewalk Ramp
CHE	• Cement • Driveway, Nonreinf Conc, 6 inch, Modified • Driveway, Nonreinf Conc, 8 inch, Modified • Detectable Warning Surface, Modified • Sidewalk Ramp, Conc, 6 inch, Modified • Sidewalk, Conc, 6 inch, Modified
C/G	• Curb, Gutter, and Curb and Gutter, Any Type, Rem • Curb and Gutter, Conc
C/GHE	• Curb, Gutter, and Curb and Gutter, Any Type, Rem • Cement • Driveway Opening, Conc, Det M, Modified
CP	• Grading, Sidewalk • Sidewalk, Conc, 4 inch, Modified
CR	• Sidewalk, Sidewalk Ramp, and Driveway Approach, Any Thickness, Rem
DS	• Dr Structure, Rem • Sewer, Rem, Less than 24 inch • Dr Structure, 24 inch dia
DSDI	• Dr Structure, Rem • Sewer, Rem, Less than 24 inch • Dr Structure, Double Inlet
PT	• Dr Structure, Point
RRA	• Dr Structure Cover, Type B • Dr Structure Cover, Type B, Special • Dr Structure, Adj, Case 1, Modified • Dr Structure, Temp Lowering, Modified
RRK	• Dr Structure Cover, Type K • Dr Structure, Adj, Case 1, Modified
RS	• Dr Structure, Reconstruct
TYPE II	• Plastic Drum, High Intensity, Lighted, Fum • Plastic Drum, High Intensity, Lighted, Oper
TYPE III	• Barricade, Type III, High Intensity, Double Sided, Lighted, Fum • Barricade, Type III, High Intensity, Double Sided, Lighted, Oper

CONSTRUCTION METHOD AND SEQUENCING

WORK ON THESE STREETS INCLUDES, BUT IS NOT LIMITED TO, THE FOLLOWING ITEMS. COMPLETE THE WORK IN ACCORDANCE WITH THE PLANS AND SPECIFICATIONS, AND AS DIRECTED BY THE ENGINEER. PERFORM THE WORK IN THE ORDER INDICATED BELOW UNLESS OTHERWISE AUTHORIZED OR DIRECTED BY THE ENGINEER.

- IMPLEMENT MAINTENANCE OF TRAFFIC (M.O.T.) PLAN, AND INSTALL SOIL EROSION AND SEDIMENTATION CONTROL MEASURES.
- CONDUCT REMOVAL WORK RELATED TO PAVEMENT, DRAINAGE, AND CONCRETE ITEMS WITH EXCEPTION TO COLDMILLING.
- INSTALL PROPOSED DRAINAGE STRUCTURES, STORM SEWER, AND UNDERDRAIN AS REQUIRED.
- PERFORM ALL CONCRETE WORK, INCLUDING RESTORATION, AS REQUIRED.
- TEMPORARY LOWER ALL STRUCTURE COVERS LOCATED WITHIN THE EXISTING PAVEMENT, INCLUDING GATE AND MONUMENT BOXES AS REQUIRED.
- REMOVE 4.0 INCHES OF EXISTING HMA SURFACE BY COLDMILLING. THIS MAY INCLUDE GRANULAR BASE MATERIAL. DEPTH TO BE DETERMINED BY THE ENGINEER. PROOF ROLL WITH FULLY LOADED TRUCK.
- PERFORM ALL JOINT AND CRACK CLEANOUT, HMA/HAND PATCHING, UNDERCUTS AND/OR BASE REPAIRS AS REQUIRED.
- GRADE, SHAPE, AND COMPACT THE EXISTING BASE MATERIAL AS REQUIRED.
- CLEAN PAVEMENT AS REQUIRED, AND PLACE 2.0 INCH LEVELING COURSE HMA MIX (LOCAL STREETS).
- ADJUST ALL STRUCTURE COVERS, INCLUDING GATE AND MONUMENT BOXES, TO THEIR FINISHED ELEVATIONS AS REQUIRED.
- CLEAN PAVEMENT AND PLACE 2.0 INCH TOP COURSE HMA MIX (LOCAL STREETS).
- CLEAN PAVEMENT AND COMPLETE ALL PAVEMENT MARKINGS.
- COMPLETE ALL MISCELLANEOUS CONSTRUCTION INCLUDING ALL CLEAN UP AND FINAL RESTORATION.
- REMOVE ALL TRAFFIC CONTROL DEVICES, AND MISS DIG FLAGS.

NOTES

FOR PROTECTION OF UNDERGROUND UTILITIES AND IN CONFORMANCE WITH PUBLIC ACT 174 OF 2013, THE CONTRACTOR SHALL CALL 811 OR 1-800-482-7171 A MINIMUM OF THREE FULL WORKING DAYS, EXCLUDING SATURDAYS, SUNDAYS, AND HOLIDAYS, PRIOR TO BEGINNING EACH EXCAVATION IN AREAS WHERE PUBLIC UTILITIES HAVE NOT BEEN PREVIOUSLY LOCATED. MEMBERS WILL THUS BE ROUTINELY NOTIFIED. THIS DOES NOT RELIEVE THE CONTRACTOR OF THE RESPONSIBILITY OF NOTIFYING UTILITY OWNERS WHO MAY NOT BE A PART OF THE "MISS DIG" ALERT SYSTEM.

THE UNDERGROUND LOCATIONS SHOWN FOR NATURAL GAS, TELEPHONE, ELECTRICAL POWER, CABLE TV AND FIBER OPTIC LINES ARE APPROXIMATE. THE CITY OF ANN ARBOR ASSUMES NO RESPONSIBILITY FOR THEIR ACCURATE REPRESENTATION IN THIS DRAWING. MISS DIG MUST BE CONTACTED PRIOR TO CONSTRUCTION TO LOCATE THESE UTILITIES.

THE IMPROVEMENTS COVERED BY THESE PLANS SHALL BE PERFORMED IN ACCORDANCE WITH MICHIGAN DEPARTMENT OF TRANSPORTATION (MDOT) 2012 STANDARD SPECIFICATIONS FOR CONSTRUCTION, INCLUDING REFERENCED MDOT PUBLICATIONS, AND THE PROJECT CONTRACT DOCUMENTS.

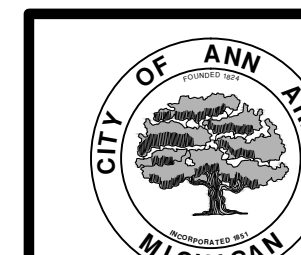

PROJECT MANAGEMENT SERVICES UNIT
CITY OF ANN ARBOR PUBLIC SERVICES
301 EAST HURON STREET, P.O. BOX 8647
ANN ARBOR, MICHIGAN 48107-8647
734-794-6410 www.a2gov.org

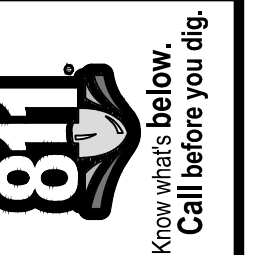

PROJECT MANAGEMENT - PUBLIC SERVICES - CITY OF ANN ARBOR
STREET RESURFACING - 2016
BEACONSFIELD DRIVE & PAGE AVENUE & TICKNOR COURT
DRAWING No. 2016004-96
SHEET No. 96 OF 98

S:\Project Management\Drafting\autocad\2016004\Plan Production\2016004-Misc Courts2.dwg Dwg Created: 30-Nov-15 - 02 standard bw.stb - Plot Date: 15-Mar-16

S:\Project Management\Drafting\autocad\2016004\Plan Production\2016004-Misc Courts2.dwg Dwg Created: 30-Nov-15 - _o2 standard bw.stb - Plot Date: 15-Mar-16



TRAFFIC CONTROL SIGN		
	SIGN	NUMBER
①		R11-4 60x30
③		W20-3 36"x36"
	STREET	D3-1
④		W20-1 36"x36"
	STREET	D3-1
⑤	W/ TYPE III BARRICADE	

LEGEND	
SYMBOL	DESCRIPTION
⊙	EXISTING SANITARY SEWER MANHOLE
⊕	EXISTING STORM SEWER MANHOLE
+	EXISTING WATER MAIN VALVE IN WELL
+	WATER MAIN GATE VALVE IN BOX
+	FIRE HYDRANT
+	MICHCON GAS CO. VALVE BOX/WELL
+	AMERITECH TELEPHONE VAULT
+	ELECTRIC MANHOLE
+	SOIL BORING
+	EXISTING STORM SEWER INLET
+	MONUMENT BOX
	REMOVE AND REPLACE CONC. SIDEWALK
	PLACE CONCRETE SIDEWALK
	REMOVE & REPLACE CONC. CURB & GUTTER
	CONSTRUCTION LIMITS
	6" WRAPPED UNDERDRAIN
	REMOVE CONCRETE SIDEWALK
	SUBGRADE UNDERCUT

PROJECT MANAGEMENT - PUBLIC SERVICES - CITY OF ANN ARBOR
STREET RESURFACING - 2016
 BEACONSFIELD DRIVE & PAGE AVENUE & TICKNOR COURT
 RESURFACING

SCALE PLAN: 1" = 40'
 DRAWING No. 2016004-97
 SHEET No. 97 OF 98

811
 Know what's below.
 Call Before you dig.

CITY OF ANN ARBOR
 PUBLIC SERVICES
 301 EAST HURON STREET
 P.O. BOX 8667
 ANN ARBOR, MI 48108-8667
 www.aagov.org

CITY OF ANN ARBOR

REV.	DATE	DESCRIPTION
02	3-15-2016	ADDENDUM #3
01	3-7-2016	ADDENDUM #1
00	2-22-2016	BID SET

S:\Project Management\Design\2015004_Resurfacing\Plan Production\TRAFFIC CALMING DET..dwg Dwg Created: 17-Feb-16 - _o2 standard bw.stb - Plot Date: 15-Mar-16

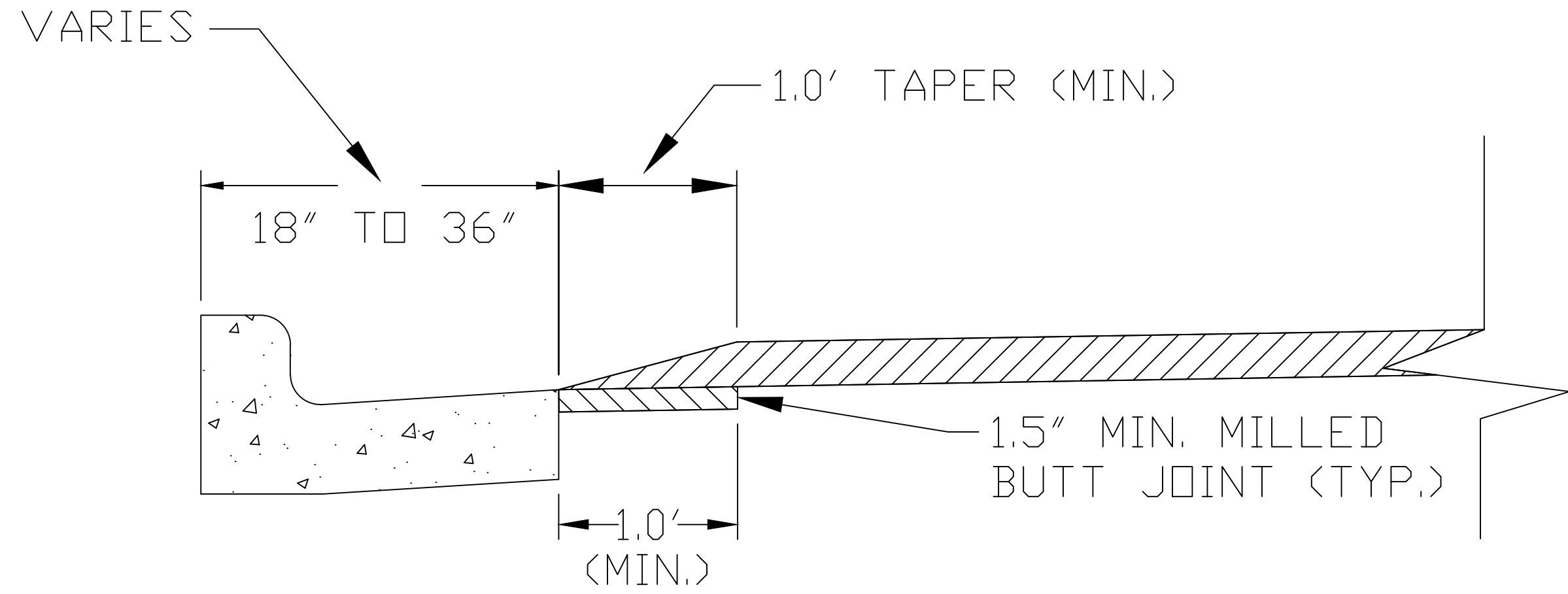

SPEED HUMP CROSS SECTION

SECTION B-B

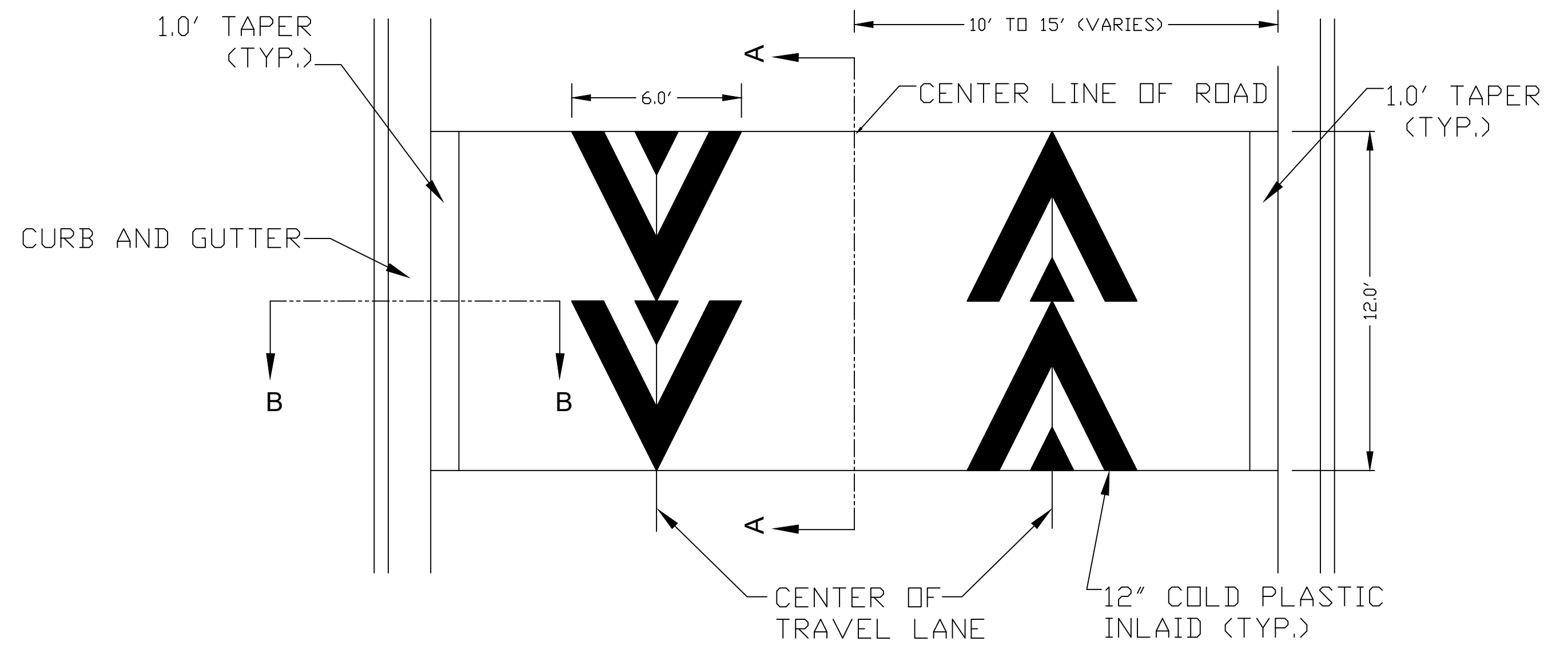

PAVEMENT MARKING DETAIL

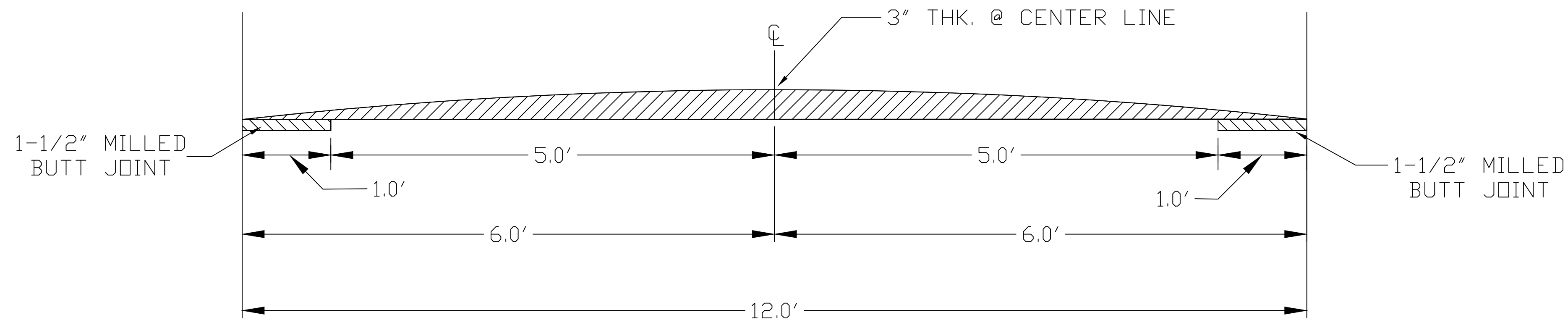

SPEED HUMP CROSS SECTION

SECTION A-A

GENERAL NOTES

1. RAISED INTERSECTIONS SHALL FOLLOW THE SAME TAPER REQUIREMENT AS THE SPEED HUMPS DETAILED HEREIN.
2. PAYMENT FOR PAVEMENT MARKINGS FOR SPEED HUMPS AND RAISED INTERSECTIONS SHALL BE INCLUDED IN THE RESPECTIVE BID ITEMS AND SHALL NOT BE PAID FOR SEPARATELY.



REV.	DATE	DESCRIPTION	DRAWN	CHECKED
02	3-15-2016	ADDENDUM #3	DAD	DAD
01	3-7-2016	ADDENDUM #1	DAD	DAD
00	2-22-2016	BID SET	SS AH JK	DAD

CITY OF ANN ARBOR
PUBLIC SERVICES
301 EAST HURON STREET
ANN ARBOR MI 48106-0667
www.a2gov.org

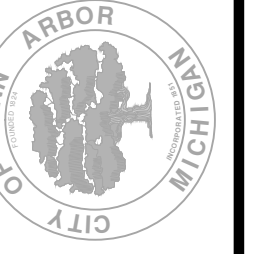

PROJECT MANAGEMENT - PUBLIC SERVICES - CITY OF ANN ARBOR
STREET RESURFACING - 2016
TRAFFIC CALMING DETAILS

SCALE: NTS
DRAWING No.
2016004-98