

ADDENDUM No. 1

RFP No. 24-03

Barton Dam Right Embankment Remediation

Due: February 29, 2024 at 3:00 PM (local time)

The following changes, additions, and/or deletions shall be made to the Request for Proposal for Barton Dam Right Embankment Remediation, RFP No. 24-03 on which proposals will be received on/or before the date and time listed above. The bid opening will be at Larcom City Hall (301 E Huron Street, Ann Arbor, MI 48104).

The information contained herein shall take precedence over the original documents and all previous addenda (if any) and is appended thereto. **This Addendum consists of seventy-six (76) pages.**

Bidder is to acknowledge receipt of this Addendum No. 1, including all attachments (if any) in its Bid by so indicating on page B-1 of the Invitation to Bid Form. Bids submitted without acknowledgment of receipt of this addendum will be considered nonconforming.

The following forms should be submitted in the proposal:

- **Attachment B – General Declarations**
- **Attachment C – Legal Status of Bidder**
- **Attachment D – City of Ann Arbor Prevailing Wage Declaration of Compliance**
- **Attachment E – City of Ann Arbor Living Wage Ordinance Declaration of Compliance**
- **Attachment G – Vendor Conflict of Interest Disclosure Form**
- **Attachment H – City of Ann Arbor Non-Discrimination Ordinance Declaration of Compliance**
- ~~**Attachment K – Federal DBE Participation – NOT USED**~~
- **Attachment L – Federal Debarment Certification**
- **Attachment Y – City of Ann Arbor Corps Water Infrastructure Financing Program (CWIFP) – Contract Addendum, Applicable Federal Requirements for CWIFP Projects November 2023 (excerpt). Submittable forms:**
 - Attachment 1 (City of Ann Arbor document). Certification Regarding Lobbying**
 - Attachment 2 (City of Ann Arbor document). Certification Regarding Debarment, Suspension and other Responsibility Matters**
 - Attachment 3 (City of Ann Arbor document). SAM Record Search**

Bids that fail to provide the completed forms listed above upon bid opening may be rejected as non-responsive and may not be considered for award.

I. CORRECTIONS/ADDITIONS/DELETIONS

Changes to the Bid document which are outlined below are referenced to a page or Section in which they appear conspicuously. The Bidder is to take note in its review of the documents and include these changes as they may affect work or details in other areas not specifically referenced here.

SECTION 1 GENERAL INFORMATION

Revise Item G

Each respondent should submit in a sealed envelope:

- One (1) original proposal
- ~~Three (3)~~ **Two (2)** additional proposal copies
- One (1) digital copy of the proposal preferably on a USB/flash drive as one file in PDF format.

BID FORM MODIFICATIONS

The following changes are being made to the Bid Form. The Bid Form is being reissued in its entirety for use in submitting the proposal:

- *Deleted Chemical and Cementitious Grouting*
- *Updated filter material quantity*
- *Updated topsoil quantity*
- *Deleted Bid Item 29*
- *Updated Class II quantity*
- *Added Alternate Bid Item A2*
- *Added Alternate Bid Item A3*

E. SCHEDULE OF PRICING/COST – 20 POINTS

Barton Dam Right Embankment Remediation

Base Bid Form

The City of Ann Arbor is issuing this request for Proposals to qualified contractors to perform earth work and other improvements associated with the Barton Dam Right Embankment Remediation project. The work area is located between Barton Pond and the Barton Nature Area Parking Area. The proposed project will entail the construction of an earthen buttress on the right embankment as well as other site improvements including widening of the existing underpass access path, replacement of the existing underpass canopy, adding a trail along the toe of the dam’s right embankment, replacement of the existing stairway to the dam crest, removal of the existing reverse filter at the site, filling of the existing toe drain pond, and **potentially** excavation of earth near the canoe launch. This compensatory cut, **near the canoe launch may be** needed to offset the fill placed within the floodplain. Any items required for a complete project that are not included in the following table shall be assumed to be incidental.

Name of Bidder: _____

Item No.	Description	Units	Quantity	Unit Cost	Total Cost
1	General Conditions, Bonds, Insurance.	LS	1		
2	Mobilization and Demobilization	LS	1		
3	Install, Maintain, and Remove SESC	LS	1		
4	Chemical Grouting at TD-23 and TD-43 Subcontractor: _____ (Estimated Quantity for Bidding Purposes) Item Removed	GAL	50 0		
5	Install Cementitious Grout Holes at TD-23 and TD-43 Subcontractor: _____ (Estimated Quantity for Bidding Purposes) Item Removed	EA	80 0		
6	Cementitious Grouting at TD-23 and TD-43 Subcontractor: _____ (Estimated Quantity for Bidding Purposes) Item Removed	CF	120 0		

Item No.	Description	Units	Quantity	Unit Cost	Total Cost
7	Site Preparation: Signage and Traffic Control, Clearing and Grubbing, Install, Maintain, and Remove Temporary Haul Route, Relocation of Emergency Stockpiles of Sand and Gravel. Demolish: Wooden Fence along Huron River, Remnant Collector Ditch Weir Posts, Steel C-Channel Toe Drain ID Posts, Block Wall and Geosynthetic Reinforcing Near TD-39, and Aggregate Ballast Upslope of TD-39, etc.	LS	1		
8	Underpass Widening: Remove Existing Pavement, Canopy, Railing, and Gabions, Prepare Subgrade, Install Modular Block Wall, Place Backfill and Temporary Surface Course on Underpass.	LS	1		
9	Remove and Replace Existing Retaining Wall North of Underpass	LS	1		
10	Strip Topsoil and Raise Grade of the Right Embankment Crest to Elevation 802.0 feet.	CY	630		
11	Reverse Filter Dewatering	LS	1		
12	Remove Reverse Filter and Backfill. Excavation shall be closed on same day it is opened.	TON	1300		
13	Topsoil Stripping at the Stabilization Berm	ACRES	2.1		
14	Excavation to Reach Subgrade of Granular Filter and Removal and Replacement of Unsuitable Soils at the Stabilization Berm, including required cuts to achieve the proposed subgrade elevation at the Stabilization Berm (Estimated Quantity for Bidding Purposes). Excavation shall be closed on same day it is opened.	TON	2000		
15	Dewater the Collector Ditch Pond and Surrounding Ground	LS	1		
16	Remove and Replace Unsuitable Soils from the Collector Ditch Pond (Estimated Quantity for Bidding Purposes)	TON	3200		
17	Fill the Collector Ditch Pond with Engineered Fill	LS	1		

Item No.	Description	Units	Quantity	Unit Cost	Total Cost
18	Realign and Construct the Collector Ditch. Remove, Relocate, and Replace the Existing Culvert. Abandon the existing headwall and construct headwalls for the relocated culvert.	LS	1		
19	Provide dewatering for collector ditch abandonment and general dewatering as necessary	LS	1		
20	Inspect and Abandon Toe Drains TD-12 through TD-59.	LS	1		
21	Place and Compact MDOT 2NS Fine Aggregate for the Stabilization Berm and Granular Filter Above and Below the Mineral Drain	CY	4900 5400		
22	Place and Compact MDOT 17A Coarse Aggregate for the Mineral Drain	CY	4000		
23	Place and Compact MDOT Class II Granular Fill for the Stabilization Berm	CY	6300 6000		
24	Place Topsoil on the Stabilization Berm	CY	1400 2500		
25	Demolish Existing Piezometer Surface Monuments. Raise Existing Piezometers and Install Locking Monuments. Install Overland Discharge of Artesian Flow at PZ-3. Install Underdrain (Perforated and Solid-Wall), Including Cleanouts, T Inspections, and Surface Monuments	LS	1		
26	Construct the Permanent Access Path and Improve Existing Path Areas South of the Underpass and North of the Underpass	LS	1		
27	Remove and Replace Stairway and Guard Railing atop the Adjacent Spillway Retaining Wall	LS	1		
28	Remove Temporary Surface Course and Construct Final Pavement at Underpass. Replace Access Path Canopy and Railing	LS	1		
29	Excavate and dispose of soils for compensatory cut — Moved to Additional Optional Bid Items	LS	1		

Item No.	Description	Units	Quantity	Unit Cost	Total Cost
30	Revegetation of the Work Area and Final Site Restoration, including repairs to Border-to-Border Path. Fill Ruts in the Existing Site Access Road and the Barton Nature Area Parking Lot.	LS	1		
31	Miscellaneous Allowance (to be used at the Owner's discretion)	LS	1	\$ 75,000.00	\$ 75,000.00
32	Permitting and Associated Requirements Allowance (permit fees and other charges paid directly to permitting agencies)	LS	1	\$ 95,000.00	\$ 95,000.00
33	Allowance for Additional FERC Requirements	LS	1	\$ 100,000.00	\$ 100,000.00
34	Allowance for Purchase of Wetland Credits per EGLE	LS	1	\$ 225,000.00	\$ 225,000.00
35	Project Closeout	LS	1		
36	Administrative Compliance with CWIFP, AIS, Davis Bacon, Certified Payroll and Other Regulatory Reporting.	LS	1		

ADDITIONAL OPTIONAL BID ITEMS ¹

Optional Item No.	Description	Units	Quantity	Unit Cost	Total Cost
A1	Between Underpass and Spillway: Remove Existing Gabions, Prepare Subgrade, Install Modular Block Wall, and Place Backfill	FEET	142		
A2	In lieu of A1, between Underpass and Spillway: Remove Existing Gabions, Prepare Subgrade, Install new gabion baskets and Place Backfill	FEET	142		
A3	<i>Excavate and dispose of soils for compensatory cut</i>	LS	1		
A4²	<i>Provide an alternate cost for Bid Item No. 8 if the modular block wall elements along the Huron River beneath the railroad underpass are replaced with gabion baskets²</i>	LS	1		

¹ To be executed at the direction of the Owner.

² **Provide a complete cost, not a deduct or add cost.**

The bid items identified above include the major items of work anticipated for the project. Detailed requirements for each element of the project are presented on the contract drawings.

Total Base Bid (Items 1 through 36) \$_____

Total Base Bid (Written)

Proposed Work Start Date _____

Total bid amount shall be shown in both words and numbers. In case of discrepancies, the amount shown in words shall govern.

Signature of Bidder _____ Date _____

Notice to Bidders:

1. Bids must be for all work elements and must have each blank space of the bid form completed.
2. The Owner reserves the right to waive any informality in any Bid, to reject any Bid, to reject all bids and to delete any part of the above items.
3. The bidder acknowledges that quantities provided are estimates and are not guaranteed and are solely for the purpose of bid comparison. Final payment for all unit price items will be based on the actual quantities. No minimum or maximum quantities are guaranteed by the Owner.
4. The Contractor is responsible for verification of all Bid quantities and to report to the Owner's Representative any discrepancies found prior to ordering materials or equipment for construction.
5. The bidder hereby certifies it has carefully examined the contract documents (including geotechnical data) provided by the Owner for bidding purposes and finds them compatible with the work requirements.
6. The bidder declares it has familiarized itself with the location of the proposed work and site conditions.
7. The foregoing unit prices shall include all applicable Federal, State and Local Taxes.
8. ***The bidder acknowledges the interim completion date for completion of the underpass widening work elements by March 31, 2025.***

Bidder must sign below that he/she has read and understood all addendums related to this project. Failure to acknowledge any addendum issued may disqualify the Bidder.

Addendum No.	Addendum Date	Signature of Bidder

F. AUTHORIZED NEGOTIATOR / NEGOTIATIBLE ELEMENTS (ALTERNATES)

Include the name, phone number, and e-mail address of persons(s) in your organization authorized to negotiate the agreement with the City.

Authorized Negotiator

Name: _____

Title: _____

Phone Number: _____

Email Address: _____

CONTRACT SPECIFICATION REVISIONS

SECTION I GENERAL INFORMATION

Add W

W. FEDERAL REQUIREMENTS

The City has applied for loan assistance through the Federal program, Corps Water Infrastructure Financing Program (CWIFP). The Contractor shall adhere to Federal requirements as specified in the November 2023 manual Applicable Federal Requirements for CWIFP Projects. Required contract language and excerpts from the CWIFP manual are included in Section VI - Attachments of these Specifications. The complete manual is available at the following website: <https://www.usace.army.mil/Missions/Civil-Works/Infrastructure/revolutionize/CWIFP/>.

Where CWIFP Federal requirements may conflict with other requirements of these Specifications, the CWIFP Federal requirements shall be followed.

SECTION 01 10 00 SUMMARY OF WORK

Revise 1.1.B. as follows:

- B. Principal items of work for the Barton Dam, Right Embankment Remediation include the following:
 - 1. ~~Grouting of Toe Drains (TDs) TD-23 and TD-43. **Not Used**~~
 - 2. Site clearing and grubbing.
 - 3. Installation, maintenance, and removal of erosion protection and stormwater management.
 - 4. Installation, maintenance, and removal of temporary construction fencing, haul roads, and signage...
 - 5. ...

Revise 1.2 Revise Drawing 39 as follows:

Toe Drain ~~Grouting and~~ Abandonment

39

SECTION 01 14 00 WORK RESTRICTIONS

Revise 1.4.A as follows:

- A. The Contractor shall schedule the work for the following tasks based on the constraints given in such a manner as to maintain the pump station operation. At a minimum, the Construction Schedule shall indicate a proposed start date and duration for each of the items listed in this section. No construction shall begin on any of the items listed in this section until the proposed schedule has been approved. Tasks to be included are:
 - 1. Install SESC measures.
 - 2. ~~Perform grouting of TD-23 and TD-43.~~
 - 3. Perform site preparation and prepare laydown area including fencing, crossing, signage, temporary haul road as well as necessary clearing and grubbing.
 - 4. Remove underpass canopy, railing, pavement, and gabions. Install modular block wall system for underpass widening, place backfill, place temporary working surface course.
 - 5. ...

Remove 1.4.B

- ~~B. Unless otherwise approved by the Engineer, the Contractor shall complete the grouting program at Toe Drains (TDs) 23 and 43 (as shown on Sheet 39 of the Drawings) within 60 days of receiving notice to proceed from the Owner or be subject to the liquidated damages specified in the contract.~~

SECTION 01 20 00 MEASUREMENT AND PAYMENT

Revise 1.2.Item No. 1.1

Item No. 1 – General Conditions, Bonds, Insurance & FERC Potential Failure Mode Analysis (PFMA) Workshop

1. Payment for this lump sum item will be ***allocated on a monthly basis per the Contractor's proposed schedule.*** ~~paid in full after proof of bonds and insurance is provided to the Engineer.~~

SECTION 01 31 00 PROJECT MANAGEMENT AND COORDINATION

Revise 1.4.A as follows:

- A. Protect survey control and reference points. Promptly notify Engineer of any discrepancies ***or damage*** discovered.

Add Section 1.11 as follows:

1.11 POTENTIAL FAILURE MODE ANALYSIS (PFMA) WORKSHOP WITH FERC

A. The Federal Energy Regulatory Commission (FERC), which licenses Barton Dam, has previously conducted a PFMA workshop with the City and the Design Team. Prior to construction commencing, FERC requires that a supplemental PFMA workshop be conducted with project staff from FERC, the City of Ann Arbor, the Design Team, and the selected contractor to review potential failure modes during construction and requirements to manage the associated risks.

B. The PFMA workshop will be conducted over a three-day period (up to 8 hours per day) The Contractor shall have the following project individuals in attendance for each PFMA session: Contractor's Project Manager and Superintendent, as well as the Dewatering Subcontractor's Superintendent and Design Engineer.

SECTION 01 35 13 GENERAL PROVISIONS

Revise 3.15.A and Add 3.15.B as follows:

- ~~A. The substantial completion date for construction is expected to be September 15, 2025, with final completion being November 30, 2025. ***The Substantial completion date is July 31, 2026 and the final completion date is October 30, 2026.***~~

- B. The Contract requires an Interim Milestone date for completion of the railroad underpass widening of no later than March 31, 2025.***

SECTION 31 23 00 EXCAVATION, BACKFILL AND COMPACTION

Add 2.1.H as follows:

2.1 MATERIALS

H. MDOT Open Graded Aggregate 34G

Material used to backfill existing toe drains shall conform to MDOT 34G open graded aggregate.

Add 3.1.H as follows:

3.1 Excavaton

H. The Contractor shall monitor weather conditions frequently such that all daily excavation and backfill requirements can be met prior to anticipated heavy rain events.

SECTION 31 23 19 DEWATERING

Updated Specification is attached in its entirety.

SECTION 31 32 23 GROUTING

Delete entire specification.

SECTION 31 36 00 GABIONS

Added Specification is attached in its entirety.

SECTION 32 93 00 VEGETATION

Add 2.2.A.1 as follows:

1. Furnish turf seed that meets specifications of an ~~80/20 Turf Type Tall Fescue Mix with perennial rye~~ **a no-mow, drought-resistant mix as given below:**
 - **15% Celestial Creeping Red Fescue**
 - **15% Big Horn Hard Fescue**
 - **15% Jetty Hard Fescue**
 - **15% Compass II Chewings Fescue**
 - **15% Sheep Fescue, Blue Hornet**
 - **15% Creeping Red Fescue**
 - **10% Annual Ryegrass**

Revise 2.3.B as follows:

- B. Erosion control blanket: Uniform open weave jute matting; excelsior matting; erosion control mulching fabric consisting of knitted construction of yarn interwoven with strips of biodegradable paper; or organic fiber protective fiber mat consisting of half-inch layer of chopped straw, knitted into mat with thin netting of biodegradable polypropylene. Shall be environmentally sensitive and certified weed ~~see~~ free. Performance capabilities shall have a shear stress rating of 84 Pa (1.75 lb/ft²) for slopes that are 2H:1V and flatter.

Revise 3.1.A as follows:

- A. The Contractor shall not begin work in this section until the final grading has been approved by the ~~Resident Project Representative~~ **Engineer**.

Revise 3.2.A as follows:

- A. Test the soil for the appropriate pH and submit test results to the ~~Resident Project Representative~~ **Engineer**.

Revise 3.3.B.C.D as follows:

- B. The seeding shall be completed within three days after completion of final grading or as soon thereafter as conditions are favorable. Seeding shall occur between ~~March 15th and September 15th~~ **April 1st until June 1st, and September 1st until October 1st**.
- C. Provide minimum ~~6~~**12** inches of topsoil (according to AASHTO T267) in areas where vegetation is to be established. The seedbed shall be prepared by pulverizing and breaking up the soil to a minimum depth of two inches with a disk harrow, drag harrow, spike tooth harrow or similar tool. All rocks over two inches in diameter, clods and undesirable material that would interfere with seeding operations shall be removed. Immediately after seedbed preparation, the Contractor shall apply the fertilizer uniformly over the area at a rate of 155 pounds per acre (3.5 pounds per 1,000 square feet). Apply fertilizers by mechanical drop or rotary distributor, thoroughly and evenly incorporated with soil to a depth of 3 inches by disking or other approved method. Fertilize areas inaccessible to power equipment with hand tools and incorporate into soil.
- D. The seed shall be drilled or broadcast uniformly over the seedbed at a rate of ~~220-450~~ pounds per acre (**510.5** pounds per 1,000 square feet) using methods and equipment acceptable to the ~~Resident Project Representative~~ **Engineer**. The seeded area shall be passed over with a cultipacker or similar tool to help cover more seed and improve seeding establishment. Application of grass seed and fertilizer at the same time, in the same machine is not permitted.

ATTACHMENT A SAMPLE STANDARD CONTRACT

Revise Article III – Time of Completion B and C as follows:

- (B) The entire work for this Contract shall be completed within ~~Seventeen (17)~~ **Twenty-Eight (28)** consecutive calendar months.
- (C) The substantial completion date is ~~September 30, 2025~~ **July 31, 2026**, and the final completion date is ~~November 15, 2025~~ **October 30, 2026**. ***The Contract requires an Interim Milestone date for completion of the railroad underpass widening of no later than March 31, 2025.***

Add ATTACHMENT Y CITY OF ANN ARBOR CORPS WATER INFRASTRUCTURE FINANCING PROGRAM (CWIFP) – CONTRACT ADDENDUM, APPLICABLE FEDERAL REQUIREMENTS FOR CWIFP PROJECTS NOVEMBER 2023 (excerpt).

Contract Drawings

Issued for Construction Contract drawings will be provided to the successful bidder upon approval of plans and specifications by the Federal Energy Regulatory Commission.

Revise

- Sheet 2 – Remove Item B from the Proposed Construction Sequence.
- Sheet 2 – Add General Note 20; All excavations associated with the project must conform to all MIOSHA requirements.
- Sheet 5 – Sheet number label should be 5 of 48.
- Sheet 7 – Note 1 tree protection detail is on Sheet 11
- Sheet 10 – Update SESC Sequence Note C “Sweeping at least three times per week” or more if required based on road conditions during active construction.
- Sheet 12 - Revise the location of the access gate to northeast of the pump station (next to creek crossing). A new lockable gate will be required to be placed at the location indicated in the sketch below.

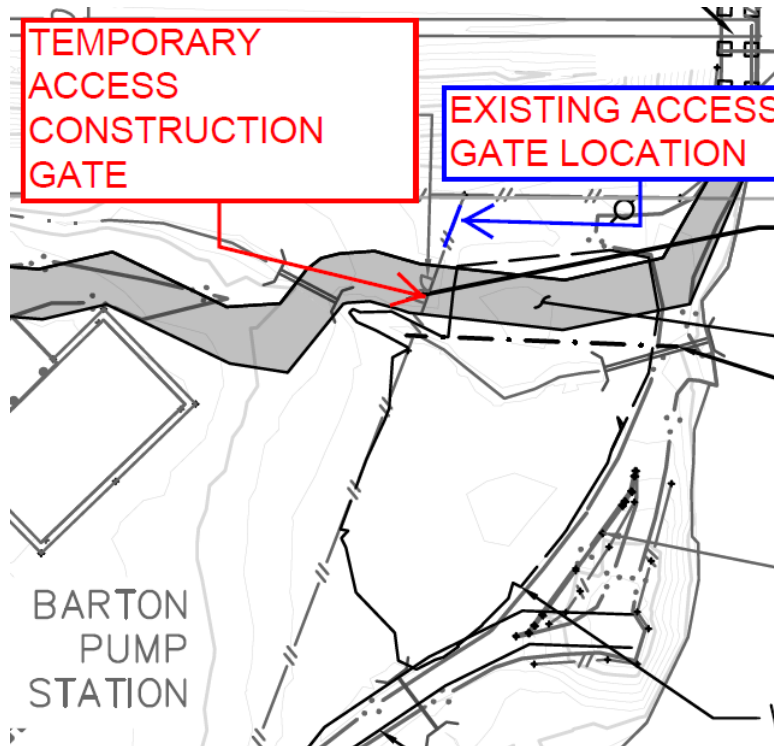

- Sheet 12 – Extend the thickened section of the access road to the construction entrance on Huron River Drive for the protection of existing watermains extending from the pump station. See sketch below:

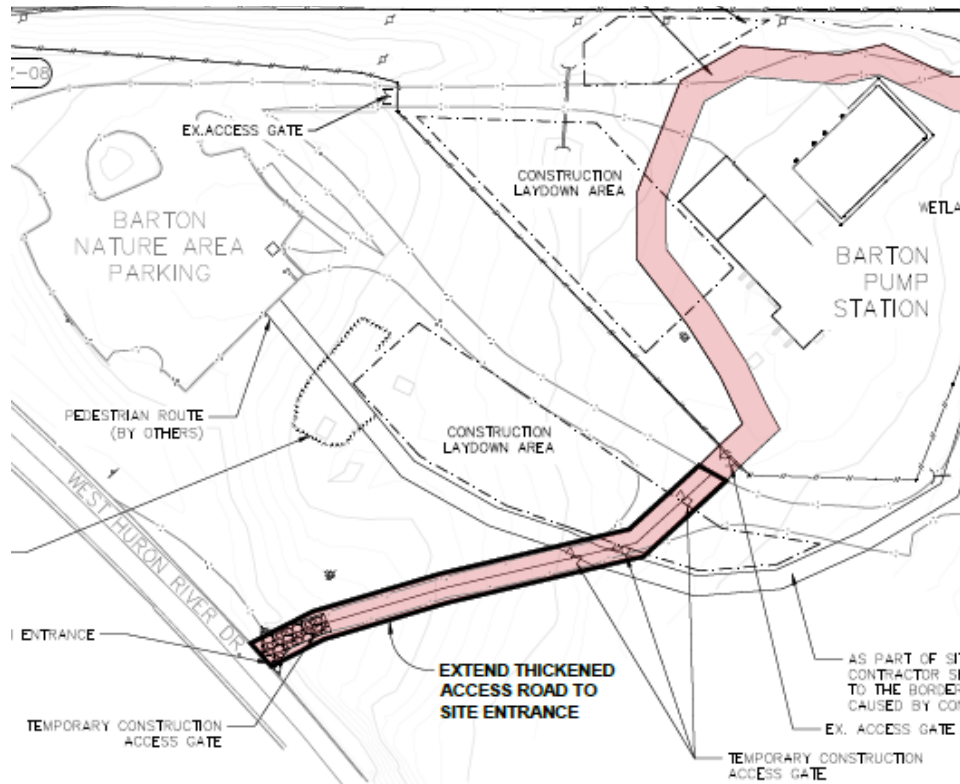

- Sheet 13 – For Note 2, unsuitable soils are those materials that when exposed contain more than 5% organic matter or those which as determined by the Engineer are unstable and will impede the placement and compaction of engineered materials associated with the stabilization berm.
- Sheet 16 - The weir posts extraction note, should be revised to say, “Cut off weir posts 6” below bottom of filter layer and leave remainder in place.
- Sheet 16 – Delete Note 5.
- Sheet 17 - Dewatering at the reverse filter must continue until the area is filled to surrounding grade and as needed to prevent soil instability caused by upward water gradients and can be discontinued upon approval of the Engineer.
- Sheet 19 – Add Note 8: “Hydraulic placement of pea gravel in the toe drains will not be permitted.”
- Sheet 19 – Under Tree Removal Sequence, Revise Note 2 to say “Stumps in the embankment shall be ground out. Stump holes and other holes from which obstructions are removed shall be backfilled as noted in Note 4”.
- Sheet 19 – Under Tree Removal Sequence, Revise Note 4 to say “Backfill the excavation with compacted MDOT 2NS Fine Aggregate to 1 foot below ground surface and finish to grade with MDOT 21AA”.
- Sheet 22 – Note 4 should be revised to say “See General Note 11. (Sheet 2) for construction equipment loading restrictions”.
- Sheet 25 – Update Note 4 to also include installing overland discharge to the proposed collector ditch with a 6” flexible HDPE pipe at PZ-6.

- Sheet 26 - Note 4 incorrectly references "Sheet XX." It should reference Sheet 39.
- Sheet 30 - The maximum cut slope for berm construction at the dam crest is 2-horizontal to 1-vertical, see Section 2. If the Engineer visually observes any indication of instability, the slope must be backfilled immediately, and the excavation resumed with more limited horizontal extent.
- Sheet 30 – Revised stabilization berm with thickened Topsoil layer to 12 inches for the entire stabilization berm and MDOT 2NS granular filter layer increased to 18 inches above the existing collector ditch for the reaches of the collector ditch that extend from TD-22 to TD-24 and from TD-42 to TD-44.

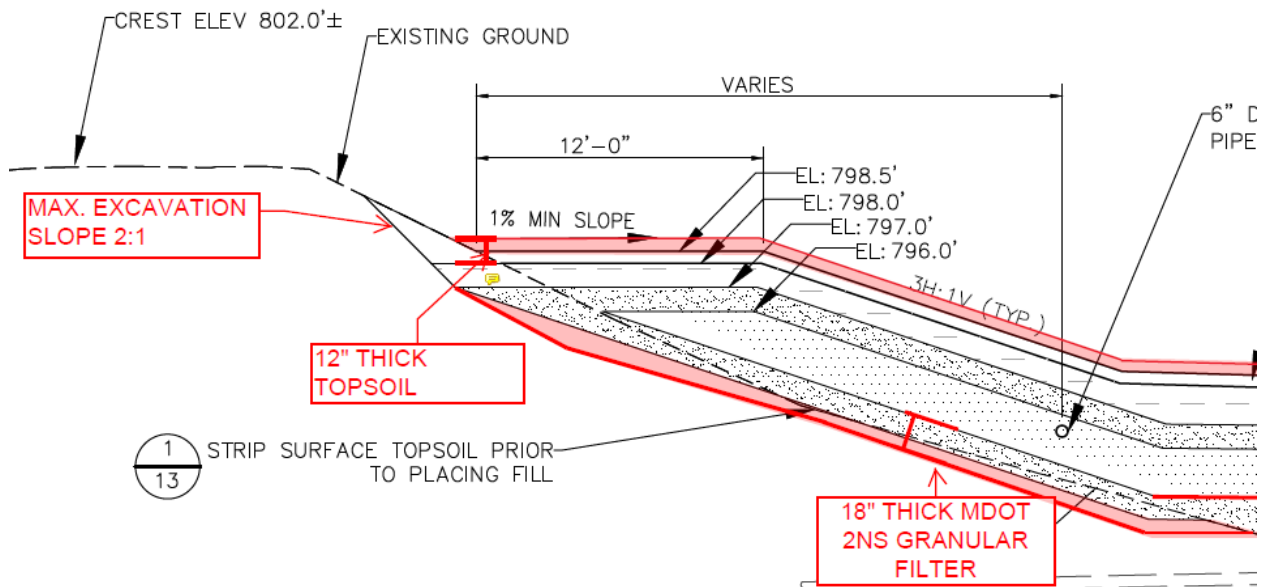

- Sheet 30 – The blanket portion of mineral drain (17A aggregate) must be constructed to the level indicated below, before discontinuing dewatering:

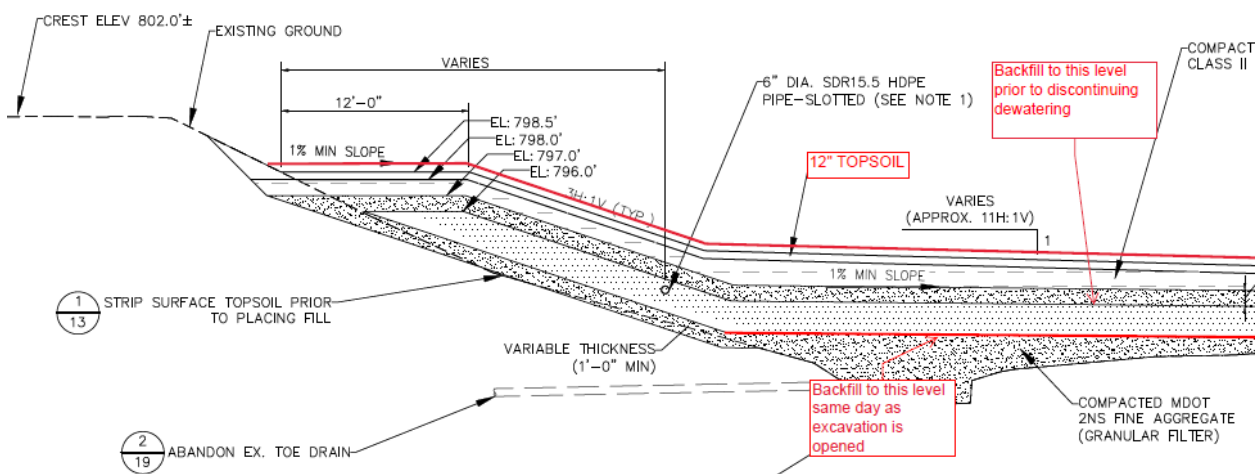

- Sheets 30 / 46 – The proposed collector ditch must be constructed to the top of the 17A aggregate before cessation of dewatering. Add note 7: Dewatering other project elements including the existing collector toe ditch abandonment must continue until the 24-inches of MDOT 17A mineral drain material is placed.

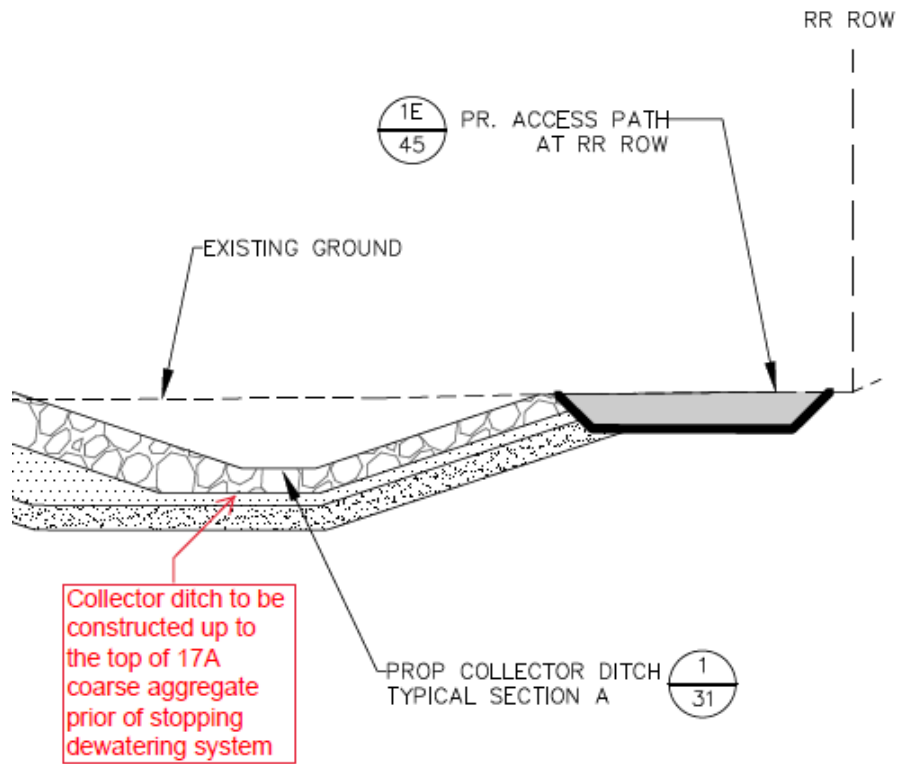

- Sheet 46 – For removal of unsuitable soils, subgrade preparation, and backfilling of the collector ditch pond, contractor shall draw ground water down to 24 inches below the lowest level of excavation and maintain it at that level for the duration of this portion of the work, The contractor may discontinue dewatering upon placement of 17A aggregate for its full depth and approval by the Engineer.
- Sheet 39 – Revise title to “Toe Drain Abandonment”. Delete Grout Hole Plan view and Grout Hole Section Detail.
- Sheet 47 - Add Note: “Permanent access path alignment will be adjusted to follow existing access path and to protect the kayak/canoe slide”.
- Sheet 48 – “Quantity for Replace Underpass Canopy” changed to 400 SF.

SECTION VI – ATTACHMENTS

Reissue in its entirety as follows:

SECTION VI – ATTACHMENTS

Attachment A – Sample Standard Contract

Attachment B – General Declarations

Attachment C - Legal Status of Bidder

Attachment D – Prevailing Wage Declaration of Compliance Form

Attachment E – Living Wage Declaration of Compliance Form

Attachment F – Living Wage Ordinance Poster

Attachment G – Vendor Conflict of Interest Disclosure Form

Attachment H – Non-Discrimination Ordinance Declaration of Compliance Form

Attachment I – Non-Discrimination Ordinance Poster

Attachment J – Davis-Bacon Wage Requirements

~~Attachment K – Federal DBE Participation~~ - **Federal CWIFP Program does not require DBE Participation. This requirement is therefore deleted from this project.**

Attachment L – Federal Debarment Certification

~~Attachment M – Federal Good Faith Efforts~~ - **Federal CWIFP Program does not require Good Faith efforts. This requirement is therefore deleted from this project.**

Attachment N – Sample Certified Payroll Report Template

Attachment O – Historic Drawings (original Record Drawings)

Attachment P – Existing Geotechnical Data

Attachment Q – Barton Dam Temporary Construction Emergency Action Plan (TCEAP)

Attachment R – Railroad Permit

Attachment S – Joint Permit Attachment T – Drilling Program Plan

Attachment U – Piezometric Monitoring Data

Attachment V – Memorandum on High Flow Mitigation at Toe Drain 23

Attachment W – Construction Dam Safety Surveillance and Monitoring Plan (CDSSMP)

Attachment X - Quality Control Inspection Program (QCIP)

Attachment Y – City of Ann Arbor Corps Water Infrastructure Financing Program (CWIFP) – Contract Addendum, Applicable Federal Requirements for CWIFP Projects November 2023 (excerpt).

II. QUESTIONS AND ANSWERS

Questions are summarized below, with answers. Respondents are directed to take note in its review of the documents of the following questions and City responses as they affect work or details in other areas not specifically referenced here.

Question 1: On the soil boring list, it indicates PZ-UR is boring TB-2202 and PZ-LR is boring 2203. The discrepancy is that borings 2202 and 2203 are shown in different locations, 150-200 feet away, from the piezometer locations. Soil boring list is on sheet 3/48 and boring locations are on page 6/48. Please advise.

Answer 1: The list provided in Sheet 3 could be misleading and has been misunderstood. This is just a list of borings separated in two separate columns. A corrected version of the table is provided below.

Soil Boring List
PZ-UR
PZ-LR
PZ-01
PZ-02
PZ-03
PZ-04
PZ-05
PZ-06
PZ-07
PZ-08
PZ-09
PZ-10
PZ-11
PZ-12
PZ-13
PZ-14
PZ-15
TB-2202
TB-2203
TB-2204
TB-2205
TB-2206
HAB-2201
HAB-2202
HAB-2203
HAB-2204
HAB-2205
HAB-2206

Question 2: During the Prebid meeting the request for additional information on the collector ditch flow was asked. Can you provide?

Answer 2: Collector ditch flows have generally been monitored on a quarterly basis over the period from 2009 until June 2023. Over this period, collector ditch flows have varied from 47 gallons per minute (gpm) in June 2023 to 220 gpm in June 2022.

Question 3: For the alternative bid item associated with removal and replacement of the existing gabions, please provide water depth information.

- Answer 3: Water depths associated with the replacement of the gabion baskets is historically in the range of 2 to 4 feet although levels can change under different flow conditions.
- Question 4: Is E – Section 01-10-00 Summary of Work B.1 – Omit?
Answer 4: Correct.
- Question 5: Schedule of Pricing Costs – Will owner issue new without Chemical Grouting Tasks?
Answer 5: An updated Bid Form with Chemical grouting struck out and other miscellaneous revisions are included with this addendum.
- Question 6: Revise Schedule of Pricing Costs to reflect “tons” for units of measure for purchased aggregates & sand.
Answer 6: The bid item is for measured quantities of aggregate placed.
- Question 7: The bid does indicate embankment crest re-grading to elevation 802.0, but elsewhere require “concrete benches” on crest to be protected. – Please clarify.
Answer 7: There are several areas within the west and east portions of the embankment that require raising the surface grade to Elevation 802.0 as noted on Sheets 24 and 26, respectively. There are concrete benches near the crest, these existing features shall be protected in accordance General Note 11 in Sheet 2.
- Question 8: Please provide details & specs for raising piezometers.
Answer 8: Details are provided on Sheet 45.
- Question 9: Are there 11 piezometers to be raised?
Answer 9: Yes, Sheet 21 includes a table with the required piezometers to be raised.
- Question 10: Please specify the anticipated award date.
Answer 10: The anticipated award date for the contract is May / June 2024 and a notice to proceed is anticipated to be issued July 1, 2024. To allow the project to fit into proposed bidders workload planning, the substantial completion date has been changed to July 31, 2026. In addition, an interim milestone date of March 31, 2025 has been established for completion of all work associated with the widening of the underpass beneath the existing railroad bridge.
- Question 11: Bid does require manifests for off-site disposal of materials. Please provide analytical data for all material anticipated to be disposed. If not available, is it contractors responsibility to analyze & characterize materials for disposal?
Answer 11: There are no known contaminants at the dam and as such, there is no analytical data available. If testing is required for disposal, the contractor should carry those costs in their bid.
- Question 12: Please confirm that bid items 4,5, and 6 will be omitted from Bid Form.
Answer 12: Confirmed. See updated Bid Form contained within this addendum.
- Question 13: Please provide any available Geotech borings & soils classification for soils beneath the gabions at railroad underpass. If soils data are not available will owner (or his engineer) provide a design for the block wall footing? If not is contractor responsible?
Answer 13: The contract specifications require the Contractor to retain a licensed engineer to design the modular block wall system and submit the design for review by the Engineer. The available geotechnical information is provided as Attachment P. TB-2202 is closest to the proposed retaining wall and underpass. Additionally, a

Mussel Survey was performed near the underpass by ASTI for project permitting purposes. This document will be included in the Issued for Construction documentation. Excerpt from the photo log table from the Mussel Survey Report is presented below:



Photo 10. Most of the substrate was cobble, with gravel, sand and silt.



Photo 11. View of boulder just under the railroad bridge.

Question 14: Please clarify bid items for which you anticipate a Pre-Installation Meeting.

Answer 14: Items of work envisioned for Pre-Installation Meetings include:

- Dewatering System
- Power Generation
- Modular Element Concrete Placement
- Modular Retaining Wall Installation
- Excavation and Backfill Sequencing and proposed equipment
- Haul Road Construction

Question 15: Clarify warranty applicability and Period of Performance.

Answer 15: Refer to Attachment A Section 25 – Responsibility for Work and Warranties.

Question 16: Are we required to power sweep Huron River Drive 3x per week?

Answer 16: Confirmed, see Specification 01 57 23 – 3 3.3 D.3

Question 17: Please clarify which method of stump removal will be required, that in Section 31-10-00-2 3.2.A.3 or per details on sheet 19 of 48?

Answer 17: Stumps shall be ground out per Section 31-10-00-2 3.2.A.3. Notes on Sheet 19 have been revised per this Addendum.

Question 18: Is the correct tolerance of Optimum Moisture +/- 2%?

Answer 18: Correct. Reference Specification Section 31 23 00 3.2 A.

Question 19: Please provide a copy of the FERC-approved Drilling Program Plan.

Answer 19: Drilling requirements are included in the plans and specifications. Bid according to the drawings and the updated Dewatering Specification.

- Question 20: Is sheet piling not permitted even if the design is sealed by a PE? With Vibration Monitoring Plan?
- Answer 20: Due to headroom limitations beneath the railroad underpass and vibration safety considerations associated with the stabilizing berm construction, the use of driven sheet piles will not be permitted for underpass widening or berm construction. However, the use of sheeting piling for other elements of the work may be considered by the Engineer and alternate pricing for gabion baskets is requested in the Bid Form.
- Question 21: Will the owner or engineer retain the Retaining Wall Design Engineer (RWDE) or does Contractor?
- Answer 21: The specifications require the contractor to retain the Retaining Wall Design Engineer for the modular wall system selected.
- Question 22: The bid documents state that a precast modular block wall shall be installed on a leveling pad and constructed in the wet. Has the engineer considered the erosive forces at the river and potential subsequent failure of the modular wall system?
- Answer 22: The design engineer retained by the contractor for the modular block wall system being proposed should evaluate the appropriate base material for the wall considering flows within the Huron River at the wall location. Based on hydraulic modeling of the Huron River in the area of the proposed modular block wall a water velocity of 6 feet per second should be considered for design of the wall base and modular wall elements.
- Question 23: Section 32-32-16, page 8 specifies Verification of Soil Compaction. Please clarify how verification of compaction is to be conducted while modular wall system is constructed in the wet.
- Answer 23: The backfill material behind the modular block wall beneath the underpass will consist of MDOT 6A aggregate. This material may require some compactive effort during placement but will not require compaction verification due to its predominately stone nature. For other materials associated with the project, verification testing will be provided by the Owner.
- Question 24: Section 32-32-16, page 11, footer 1 states "Exposure class should be specified by city/purchaser prior to order placement." Please clarify if the intent is to specify exposure class prior to design.
- Answer 24: The exposure class for the concrete mix is considered as "severe" as noted in Concrete Mix Properties table under 2.1C.
- Question 25: Seed placement says topsoil to be decompacted 12" deep (ref. Specification 32 93 00 Vegetation). Is the intention to mix topsoil with backfill prior to seeding?
- Answer 25: The intention is for any topsoil that has been compacted in the embankment due to construction activity prior to seeding to be sufficiently decompacted to facilitate seed germination and growth.
- Question 26: Please provide details and specifications for stormwater culverts.
- Answer 26: Refer to Sheet 42 for proposed Culver Outlet Headwall, proposed culvert profile and pipe requirements. Refer to Specification 33 42 13 Section 2.1 for HDPE Culvert
- Question 27: What Type of temporary wearing course is needed at 2' thick at underpass. (Sheet 44, note 4)
- Answer 27: Wearing course material shall consist of 21AA. The bidder/contractor may suggest an alternative for approval.

Question 28: What is the length of the new Canopy?

Answer 28: Approximately 32 feet long.

Question 29: How many tee's and wye's are there for the new underdrain system?

Answer 29: Sheet 48 provides the quantities for underdrain Cleanouts and T inspection Lines.

END OF ADDENDUM

Section 31 23 19 Dewatering

**SECTION 31 23 19
DEWATERING**

PART 1 GENERAL

1.1 GENERAL DESCRIPTION

- A. For the following project elements, positive dewatering using wellpoints or dewatering wells will be required for:
 - a. Reverse Filter Removal
 - b. Collector Ditch Pond dewatering, removal of sediments and backfilling
 - c. Existing Collector Toe Ditch Abandonment

- B. Dewatering may also be required to maintain dam stability if unsuitable soils or soils that exhibit instability are identified, during topsoil removal from the existing dam embankment or other excavation and require removal below the phreatic water surface within the dam.

- C. At all locations where proposed construction work requires dewatering, the dewatering system shall be designed and constructed by the Contractor. The locations and designs of the dewatering systems shall be the responsibility of the Contractor and presented in a plan submitted to the City for approval. For work elements requiring dewatering, including the reverse filter removal, backfilling the existing collector ditch and collector ditch pond, relocation of the existing collector ditch and where required for removal of any unsuitable soils, ground water shall be drawn down to 24 inches below the lowest level of excavation for any project element and maintained at that level for the duration of the construction effort required for each element.

- D. The Contractor shall not perform excavations for any dewatering efforts outside of the limits indicated explicitly on the Contract Documents. Any dewatering efforts shall comply with all regulatory permit restrictions imposed on the project including the EGLE/USACE Joint Permit Application (JPA), or other applicable permits.

- E. At any point during the work, should excavation instability be identified as a result of ineffective groundwater control, the resident engineer shall have the authority to stop work and direct excavations to be backfilled until groundwater has been successfully drawn down and the threat of instability removed.

- F. The Contractor designing, constructing, or operating dewatering systems shall have a minimum of 5 years of experience in performing the type of work on similar type projects. The Contractors' site superintendent / foreman shall have a minimum of 5 years of experience on similar type projects.

- G. Soil boring logs and laboratory test results from soil borings performed at the site are available in ATTACHMENT P.

The Contractor shall submit Dewatering Plans to the City at least 30 days prior to the start of construction for removal of the existing reverse filter, the cleanout and backfilling of the existing toe ditch pond, as well as abandonment and backfilling of the existing collector

ditch. The plan shall be sealed by a Professional Engineer, licensed in the State of Michigan. The plan submitted will require approval by the Engineer and must comply with the requirement of the FERC-approved Drilling Program Plan (DPP). The dewatering plans shall present, at a minimum, the following information:

1. Locations and details regarding the dewatering system including, but not limited to, well points, dewatering wells, piping, electrical sources, and discharge points. Sheet piling shall not be permitted as part of any coffering or temporary shoring system.
 2. Critical dewatering areas include the reverse filter, the existing collector ditch pond, and the existing collector toe ditch. If dewatering efforts in these areas are interrupted, it may result in damage to the constructed work, or instability to the existing features of the dam. As such, redundant systems (such as power) shall be incorporated into the dewatering plans.
 3. The means for monitoring and testing of discharge water to ensure that piping or removal of embankment or foundation materials during dewatering operations is not occurring will be the use of a weir box. For the project the use of sediment bags will not be permitted. The contractor provided a weir box shall allow for visual observation for the presence of fines being pumped during the dewatering process. If sediments are noted in the discharge at any time, the contractor shall take immediate action to eliminate the discharge of any soil fines.
 4. Any Erosion and Sediment Control structures required in accordance with Section 01 57 13.
- H. The Contractor shall verify that geotechnical instrumentation baseline readings were obtained prior to initiating the dewatering system.
- I. Cofferdams will not be allowed as part of this construction unless approved by the Engineer in writing.
- J. Hours of operation for power-operated construction-type devices shall be limited to those listed in Section 01 35 13, General Provisions, as well as City of Ann Arbor regulations regarding operation of engines within the city limits. An exception to this restriction is allowed for the case where electrical service to operate a dewatering system becomes unavailable and backup power generating devices (e.g. diesel generators) are required.
- K. During critical dewatering operations (if any) the Contractor shall maintain, on-site, backup power generating devices (e.g. diesel generators) as required to operate dewatering pumps in the event that electrical service becomes unavailable (e.g. during power outages). The Contractor shall also have in-place the means, methods, and procedures necessary to switch over to the backup power generating devices in a timely manner as required to prevent damage to the embankment in the event that the dewatering system should fail to operate.
- L. Upon initiation of any dewatering system, or significant change thereto, as determined by the Engineer, the contractor shall have continuous on-site presence for the initial three days of dewatering. After this period of time, when dewatering systems are active, the contractor shall have an alarm system in place to remotely alert the Contractor's designated responsible person if the dewatering system is not operating as intended. In

the event of an alarm, the Contractor must restore service within a period no greater than 4 hours.

- M. Effluent from the dewatering system(s) must be discharged through a weir box with white floor and sides to facilitate inspection and sampling of the effluent by the Resident Engineer. Discharge to a filter bag is not permitted.
- N. The Resident Engineer will observe the dewatering discharge several times each day for the presence of soil particles. If the volume of soil in the effluent is noted to increase for three subsequent observations, the Contractor shall immediately investigate the cause of the soil piping and correct the issue to the Engineer's satisfaction.
- O. For each project element for which dewatering is required, the Contractor may not shut down the element specific dewatering system until the shutdown is approved by the Resident Engineer.
- P. Existing monitoring wells and piezometers shall not be used for dewatering purposes.
- Q. Following the completion of dewatering, any wells or well points used for dewatering purposes will be cut-off a minimum of 6-inches below grade and filled with cement slurry. Extraction of wellpoints or screens will not be permitted.
- R. Submittals
 - 1. Submit, for Engineer's record, a copy of all discharge permits.
 - 2. Submit plans and specific component documentation for the proposed dewatering system, including sediment monitoring method, standby equipment and power supply, groundwater disposal plan, supervisor resume.
 - 3. Submit a quality control/quality assurance plan for the dewatering plan.

PART 2 MATERIALS

- A. Provide materials and equipment suitable to meet the design requirements.

PART 3 EXECUTION

(Not Used)

END OF SECTION

SECTION 31 36 00 GABIONS

**SECTION 31 36 00
GABIONS**

PART 1 GENERAL

1.1 SUMMARY

- A. This section includes requirements for furnishing, assembling, filling, and tying double twist woven wire mesh gabion baskets for use beneath the railroad underpass as well as along the Barton Dam tailrace shoreline.
- B. Furnish all labor, materials, equipment, and incidentals needed to complete the Work.

1.2 REFERENCES

United Facilities Guide Specifications (UFGS) Section 31 36 00 Gabions

- A. MDOT, 2020 Standard Specifications for Construction (SSC), Section 902 Aggregates
- B. ASTM A90/A90M, Standard Test Method for Weight of Coating on Iron and Steel Articles with Zinc or Zinc-Alloy Coatings
- C. ASTM A370, Test Methods and Definitions for Mechanical Testing of Steel Products
- D. ASTM A428/A428M, Standard Test Method for Weight (Mass) of Coating on Aluminum-Coated Iron or Steel Articles
- E. ASTM A641/A641M, Specification for Zinc-Coated (Galvanized) Carbon Steel Wire
- F. ASTM A764, Specification for Metallic Coated Carbon Steel Wire, Coated at Size and Drawn to Size for Mechanical Springs
- G. ASTM A856, Standard Specification for Zinc-5% Aluminum-Mischmetal Alloy-Coated Carbon Steel Wire
- H. ASTM A902, Terminology Relating to Metallic Coated Steel Products
- I. ASTM A975, Standard Specification for Double-Twisted Hexagonal Mesh Gabions and Revet Mattresses (Metallic-Coated Steel Wire or Metallic-Coated Steel Wire with Poly Vinyl Chloride (PVC) Coating)
- J. ASTM C33, Standard Specification for Concrete Aggregates
- K. ASTM C136, Standard Test Method for Sieve Analysis of Fine and Coarse Aggregates

- L. ASTM C974, Standard Practice for Preparing Test Specimens from Basic Refractory Castable Products by Casting
- M. ASTM C975, Standard Practice for Preparing Test Specimens from Basic Refractory Ramming Products by Pressing
- N. ASTM D5312, Evaluation of Durability of Rock for Erosion Control Under Freezing and Thawing Conditions
- O. D6711, Standard Practice for Specifying Rock to Fill Gabions, Revet Mattresses, and Gabion Mattresses
- P. AASHTO M288, Standard Specification for Geosynthetic Specification for Highway Applications
- Q. EN 10245-1, Steel wire and wire products - Organic coatings on steel wire – Part 1: General Rules

1.3 DEFINITIONS

- A. Gabion: double-twisted wire mesh cages, uniformly partitioned into cells, connected with other similar units, and filled with stone at the project site to form flexible, permeable, monolithic structures.
- B. Reno mattress: a double-twisted wire mesh container uniformly partitioned into internal cells with relatively small height in relation to other dimensions, having smaller mesh openings than the mesh used for gabions; interconnected with other similar units and filled with stone at the project site to form flexible, permeable, monolithic channel linings, revetments, scour protections and other erosion control structures.
- C. Stone Fill: rock filling the gabion baskets.

1.4 SUBMITTALS

- A. Gabion Plan: submit a plan from an engineer licensed in the State of Michigan that outlines the requirements for the gabion baskets and stone fill that meet the criteria outlined in Paragraph 2.01(A) and meet required factors of safety for failure modes associated with a gravity retaining wall system.
- B. Test Reports:
 - 1. Stone Fill: test reports summarizing the results of the testing procedures of ASTM C33 and ASTM C136.
- C. Certificates:
 - 1. Stone Fill: submit proof that the stone fill used in the Gabion Baskets meets

the requirements outlined in the approved Gabion Plan.

2. Gabion Baskets: certification that the wire baskets comply to the specifications in ASTM C974 or ASTM C975.
- D. Qualifications: submit proof that the contractor has prior experience installing Gabion baskets at a similar scale and under similar conditions to those shown on the drawings.
- E. Shop Drawings: submit shop drawings of the gabion baskets from the chosen manufacturer that meet the requirements of the approved Gabion Plan.
- F. Manufacturer Specifications: submit product specifications of the gabion baskets from the chosen manufacturer that meet the requirements of the approved Gabion Plan.
- G. Assembly Procedure: submit a summary of the proposed assembly and placement procedure of the gabion baskets to the Engineer for review and approval.

1.5 DELIVERY, STORAGE, AND HANDLING

- A. Manufacture gabions with all components mechanically connected at the production facility. All gabions are supplied in the collapsed form, either folded or bundled for shipping. Bundles are banded together at the factory for ease of shipping and handling. Deliver gabions to the jobsite labeled in bundles. Labels show the dimensions of the gabions included the number of pieces. Lacing wire shall be shipped in coils, fasteners in boxes and preformed stiffeners in bundles. The supply to the jobsite of unassembled individual wire mesh components (panels) forming gabions will not be permitted.

PART 2 PRODUCTS

2.1 MATERIALS

- A. High Abrasion Resistant (HAR) Polymer Coated Gabions baskets (including wire type, mesh size, wire diameter, metallic coating, and rock fill) shall be designed by an engineer licensed in the State of Michigan to meet the following criteria:
 1. Adequate for permanent placement.
 2. Adequate rock fill size to allow the system to be globally and internally stable.
 3. Adequate basket size to allow the system to be globally and internally stable based on the proposed placement, fastening methods, and existing conditions.
 4. Adequate weight to support the proposed canopy frame and walkway.

5. Ability to withstand wave velocities up to 6 ft/s from the Huron River.
 6. Resistant to deterioration from periodic to constant submersion in fresh water.
 7. Resistant to deterioration from freeze/thaw cycles.
 8. Combatable with the existing gabion baskets and mattress to provide a widened gabion basket retaining wall and shore protection.
 9. The basket mesh shall be either:
 - a. Welded wire mesh in compliance with ASTM A974 with a uniform square or rectangular pattern and a resistance weld at each intersection. The welded wire connections shall conform to the requirements of ASTM A185, including wire smaller than W1.2 (0.124 in.). The wire mesh shall be galvanized before forming into mesh. Spiral binders, lacing wire, and stiffeners shall be produced from zinc-5 percent aluminum-mischmetal alloy (Zn-5Al-MM) coated wire.
 - b. Double twisted wire mesh which is zinc coated in compliance with ASTM A975. Fasteners, lacing wire, and stiffeners shall be produced from zinc-coated wire.
 10. Gabion Baskets shall have a height of 12 inches or greater.
 11. Gabion Baskets shall be fabricated within a dimension tolerance of plus or minus 5%.
 12. Ensure metallic coating weights conform to the requirements of ASTM A90, ASTM A428, or ASTM A856 as applicable.
- B. High Abrasion Resistant (HAR) Polymer Coated Reno Mattress is a double-twisted wire mesh mattress manufactured with a non-raveling mesh made by twisting continuous pairs of wires through three half turns (commonly called double-twisted) to form a hexagonal-shaped opening. Reno mattress sizes, wire diameters, mesh opening size, and tolerances shall comply with the requirements of ASTM A975. Reno mattresses are classified according to the wire coating, which is applied prior to manufacturing the mesh. HAR polymer coated Reno mattresses are manufactured from a heavily zinc coated soft or medium temper steel and overcoated with high abrasion resistant polymer as per ASTM A975.
- C. Mattress and Gabion baskets shall be fabricated, assembled, and installed in accordance with the nominal wire sizes and dimensions found in the approved Gabion shop drawings.
- D. Stone Fill must adhere to the aggregate requirements outlined in 2020 MDOT SSC, Section 902 Aggregates.

PART 3 EXECUTION

3.1 MATRESS FOUNDATION PREPARATION

- A. Site conditions are to be field verified prior to placing gabions to confirm the stability of the existing gabions and gabion mattress. Gabions and bedding or specified geotextiles shall not be placed until the foundation preparation is completed, and the subgrade surfaces have been inspected and approved by the Engineer.
- B. Surface irregularities, loose material, vegetation, and all foreign matter shall be removed from the proposed gabion wall extension foundation surface area.
- C. The surface of the finished material shall be to grade and free of mounds, dips, or windrows. Extra care should be taken with foundation preparations to ensure a level and smooth surface.

3.2 ASSEMBLY AND PLACEMENT

- A. The assembly and placement of gabions shall be per the approved assembly procedure.
- B. Stone fill shall be placed in the baskets by hand, No dumping of stone into the baskets will be allowed.
- C. Any damage to the wire or coatings during assembly, placement and filling shall be repaired promptly per the manufacturer's recommendations or replaced with undamaged gabion baskets.

END OF SECTION

**Attachment Y – City of Ann Arbor Corps Water Infrastructure
Financing Program (CWIFP) – Contract Addendum,
Applicable Federal Requirements for CWIFP Projects
November 2023 (excerpt)**

CITY OF ANN ARBOR
CORPS WATER INFRASTRUCTURE FINANCING PROGRAM (CWIFP)
CONTRACT ADDENDUM

Notice: The contract or purchase order related to the City of Ann Arbor Barton Dam Right Embankment Remediation Project to which this addendum is attached may be funded, entirely or in part, through the City's participation in the Corps Water Infrastructure Financing Program (CWIFP). In the event such funding is approved and used, the City and its contractor for the Project must comply with the terms of CWIFP, including applicable federal requirements.

Additional information and a copy of the Applicable Federal Requirements for CWIFP Projects is available at the following webpage, and see Documents – Applicable Federal Requirements for CWIFP Projects:

<https://www.usace.army.mil/Missions/Civil-Works/Infrastructure/revolutionize/CWIFP/>

The following CWIFP terms and conditions apply to you, the contractor or vendor, as a contractor of the City of Ann Arbor:

1. **Debarment and Suspension.** Contractor certifies that it will not knowingly enter into a contract with anyone who is ineligible under the 2 CFR part 180 and part 1532 (per Executive Order 12549, 51 FR 6370, February 21, 1986) or who is prohibited under Section 306 of the Clean Air Act or Section 508 of the Clean Water Act to participate in the Project. Suspension and debarment information can be accessed at <http://www.sam.gov>. Contractor represents and warrants that it has or will include a term or conditions requiring compliance with this provision in all of its subcontracts under this Agreement. See, Attachments 2 and 3.
2. **Federal Lobbying Restrictions (31 U.S.C 1352).** Recipients of federal financial assistance may not pay any person for influencing or attempting to influence any officer or employee of a federal agency, a member of Congress, an officer or employee of Congress, or an employee of a member of Congress with respect to the award, continuation, renewal, amendment, or modification of a federal grant, loan, or contract. Upon award of this contract, Contractor shall complete and submit to the City the Certification Regarding Lobbying (Attachment 1) and Disclosure of Lobbying Activities (SF-LLL) form. Contractor shall also require all subcontractors and suppliers of any tier awarded a subcontract over \$100,000 to similarly complete and submit the Certification Regarding Lobbying and Disclosure of Lobbying Activities form.
3. **Civil Rights and Non-Discrimination Obligations.** Contractor shall comply with the following federal non-discrimination requirements:
 - A. Title VI of the Civil Rights Act of 1964, which prohibits discrimination based on race, color, and national origin, including limited English proficiency (LEP). (42 U.S.C 2000D, et. seq)
 - B. Section 504 of the Rehabilitation Act of 1973, which prohibits discrimination against persons with disabilities. (29 U.S.C. 794, supplemented by EO 11914, 41 FR 17871, April 29, 1976 and EO 11250, 30 FR 13003, October 13, 1965)
 - C. The Age Discrimination Act of 1975, which prohibits age discrimination. (42 U.S.C 6101 et. seq)

4. Equal Employment Opportunity (EEO).

- A. The Contractor shall comply with Executive Order 11246, entitled 'Equal Employment Opportunity,' as amended by Executive Order 11375, and as supplemented in Department of Labor regulations (41 CFR Part 60). (EO 11246, 30 FR 12319, September 28, 1965)
- B. Contractor's compliance with Executive order 11246 shall be based on implementation of the Equal Opportunity Clause, and specific affirmative active obligations required by the Standard Federal Equal Employment Opportunity Construction Contract Specifications, as set forth in 41 CFR Part 60-4.
- C. During the performance of this contract, the contractor agrees as follows:

The contractor will not discriminate against any employee or applicant for employment because of race, color, religion, sex, sexual orientation, gender identity, or national origin. The contractor will take affirmative action to ensure that applicants are employed, and that employees are treated during employment, without regard to their race, color, religion, sex, sexual orientation, gender identity, or national origin. Such action shall include, but not be limited to the following: employment, upgrading, demotion, or transfer; recruitment or recruitment advertising; layoff or termination; rates of pay or other forms of compensation; and selection for training, including apprenticeship. The contractor agrees to post in conspicuous places, available to employees and applicants for employment, notices to be provided by the contracting officer setting forth the provisions of this nondiscrimination clause.

- D. The contractor will, in all solicitations or advancements for employees placed by or on behalf of the contractor, state that all qualified applicants will receive consideration for employment without regard to race, color, religion, sex, sexual orientation, gender identity, or national origin.
- E. The contractor will not discharge or in any other manner discriminate against any employee or applicant for employment because such employee or applicant has inquired about, discussed, or disclosed the compensation of the employee or applicant or another employee or applicant. This provision shall not apply to instances in which an employee who has access to the compensation information of other employees or applicants as a part of such employee's essential job functions discloses the compensation of such other employees or applicants to individuals who do not otherwise have access to such information, unless such disclosure is in response to a formal complaint or charge, in furtherance of an investigation, proceeding, hearing, or action, including an investigation conducted by the employer, or is consistent with the contractor's legal duty to furnish information.
- F. The contractor will send to each labor union or representative of workers with which he has a collective bargaining agreement or other contract or understanding, a notice, to be provided by the agency contracting officer, advising the labor union or workers' representative of the contractor's commitments under Section 202 of Executive Order No. 11246 of September 24, 1965, and shall post copies of the notice in conspicuous places available to employees and applicants for employment.

- G. The contractor will comply with all provisions of Executive Order No. 11246 of Sept. 24, 1965, and of the rules, regulations, and relevant orders of the Secretary of Labor.
- H. The contractor will furnish all information and reports required by Executive Order No. 11246 of September 24, 1965, and by the rules, regulations, and orders of the Secretary of Labor, or pursuant thereto, and will permit access to his books, records, and accounts by the contracting agency and the Secretary of Labor for purposes of investigation to ascertain compliance with such rules, regulations, and orders.
- I. In the event of the contractor's noncompliance with the nondiscrimination clauses of this contract or with any of such rules, regulations, or orders, this contract may be cancelled, terminated, or suspended in whole or in part and the contractor may be declared ineligible for further Government contracts in accordance with procedures authorized in Executive Order No. 11246 of Sept. 24, 1965, and such other sanctions may be imposed and remedies invoked as provided in Executive Order No. 11246 of September 24, 1965, or by rule, regulation, or order of the Secretary of Labor, or as otherwise provided by law.
- J. The contractor will include the provisions of paragraphs 5(A) through (H) below in every subcontract or purchase order unless exempted by rules, regulations, or orders of the Secretary of Labor issued pursuant to Section 204 of Executive Order No. 11246 of September 24, 1965, so that such provisions will be binding upon each subcontractor or vendor. The contractor will take such action with respect to any subcontract or purchase order as may be directed by the Secretary of Labor as a means of enforcing such provisions including sanctions for noncompliance: Provided, however, that in the event the contractor becomes involved in, or is threatened with, litigation with a subcontractor or vendor as a result of such direction, the contractor may request the United States to enter into such litigation to protect the interests of the United States. (Sec. 202 amended by EO 11375 of Oct. 13, 1967, 32 FR 14303, 3 CFR, 1966–1970 Comp., p. 684, EO 12086 of Oct. 5, 1978, 43 FR 46501, 3 CFR, 1978 Comp., p. 230, EO 13665 of April 8, 2014, 79 FR 20749, EO 13672 of July 21, 2014, 79 FR 42971)

5. Standard Federal Equal Employment Opportunity Construction Contract Specifications. (41 CFR 60-4.3)

- A. As used in these specifications:
 - i. "Covered area" means the geographical area described in the solicitation from which this contract resulted;
 - ii. "Director" means Director, Office of Federal Contract Compliance Programs, United States Department of Labor, or any person to whom the Director delegates authority;
 - iii. "Employer identification number" means the Federal Social Security number used on the Employer's Quarterly Federal Tax Return, U.S. Treasury Department Form 941.
 - iv. "Minority" includes:

- a. Black (all persons having origins in any of the Black African racial groups not of Hispanic origin);
- b. Hispanic (all persons of Mexican, Puerto Rican, Cuban, Central or South American or other Spanish Culture or origin, regardless of race);
- c. Asian and Pacific Islander (all persons having origins in any of the original peoples of the Far East, Southeast Asia, the Indian Subcontinent, or the Pacific Islands); and
- d. American Indian or Alaskan Native (all persons having origins in any of the original peoples of North America and maintaining identifiable tribal affiliations through membership and participation or community identification).

If the Contractor is participating (pursuant to 41 CFR 60-4.5) in a Hometown Plan approved by the U.S. Department of Labor in the covered area either individually or through an association, its affirmative action obligations on all work in the Plan area (including goals and timetables) shall be in accordance with that Plan for those trades which have unions participating in the Plan. Contractors must be able to demonstrate their participation in and compliance with the provisions of any such Hometown Plan. Each Contractor or Subcontractor participating in an approved Plan is individually required to comply with its obligations under the EEO clause, and to make a good faith effort to achieve each goal under the Plan in each trade in which it has employees. The overall good faith performance by other Contractors or Subcontractors toward a goal in an approved Plan does not excuse any covered Contractor's or Subcontractor's failure to take good faith efforts to achieve the Plan goals and timetables.

- B. The Contractor shall implement the specific affirmative action standards provided in paragraphs 6 a through n of these specifications. The goals set forth in the solicitation from which this contract resulted are expressed as percentages of the total hours of employment and training of minority and female utilization the Contractor should reasonably be able to achieve in each construction trade in which it has employees in the covered area. Covered Construction contractors performing construction work in geographical areas where they do not have a Federal or federally assisted construction contract shall apply the minority and female goals established for the geographical area where the work is being performed. Goals are published periodically in the Federal Register in notice form, and such notices may be obtained from any Office of Federal Contract Compliance Programs office or from Federal procurement contracting officers. The Contractor is expected to make substantially uniform progress in meeting its goals in each craft during the period specified.
- C. Neither the provisions of any collective bargaining agreement, nor the failure by a union with whom the Contractor has a collective bargaining agreement, to refer either minorities or women shall excuse the Contractor's obligations under these specifications, Executive Order 11246, or the regulations promulgated pursuant thereto.
- D. In order for the nonworking training hours of apprentices and trainees to be counted in meeting the goals, such apprentices and trainees must be employed by the Contractor

during the training period, and the Contractor must have made a commitment to employ the apprentices and trainees at the completion of their training, subject to the availability of employment opportunities. Trainees must be trained pursuant to training programs approved by the U.S. Department of Labor.

- E. The Contractor shall take specific affirmative actions to ensure equal employment opportunity. The evaluation of the Contractor's compliance with these specifications shall be based upon its effort to achieve maximum results from its actions. The Contractor shall document these efforts fully, and shall implement affirmative action steps at least as extensive as the following:
- i. Ensure and maintain a working environment free of harassment, intimidation, and coercion at all sites, and in all facilities at which the Contractor's employees are assigned to work. The Contractor, where possible, will assign two or more women to each construction project. The Contractor shall specifically ensure that all foremen, superintendents, and other on-site supervisory personnel are aware of and carry out the Contractor's obligation to maintain such a working environment, with specific attention to minority or female individuals working at such sites or in such facilities.
 - ii. Establish and maintain a current list of minority and female recruitment sources, provide written notification to minority and female recruitment sources and to community organizations when the Contractor or its unions have employment opportunities available, and maintain a record of the organizations' responses.
 - iii. Maintain a current file of the names, addresses and telephone numbers of each minority and female off-the-street applicant and minority or female referral from a union, a recruitment source or community organization and of what action was taken with respect to each such individual. If such individual was sent to the union hiring hall for referral and was not referred back to the Contractor by the union or, if referred, not employed by the Contractor, this shall be documented in the file with the reason therefor, along with whatever additional actions the Contractor may have taken.
 - iv. Provide immediate written notification to the Director when the union or unions with which the Contractor has a collective bargaining agreement has not referred to the Contractor a minority person or woman sent by the Contractor, or when the Contractor has other information that the union referral process has impeded the Contractor's efforts to meet its obligations.
 - v. Develop on-the-job training opportunities and/or participate in training programs for the area which expressly include minorities and women, including upgrading programs and apprenticeship and trainee programs relevant to the Contractor's employment needs, especially those programs funded or approved by the Department of Labor. The Contractor shall provide notice of these programs to the sources compiled under F(ii) above.
 - vi. Disseminate the Contractor's EEO policy by providing notice of the policy to unions and training programs and requesting their cooperation in assisting the Contractor in meeting its EEO obligations; by including it in any policy manual and collective

bargaining agreement; by publicizing it in the company newspaper, annual report, etc.; by specific review of the policy with all management personnel and with all minority and female employees at least once a year; and by posting the company EEO policy on bulletin boards accessible to all employees at each location where construction work is performed.

- vii. Review, at least annually, the company's EEO policy and affirmative action obligations under these specifications with all employees having any responsibility for hiring, assignment, layoff, termination or other employment decisions including specific review of these items with onsite supervisory personnel such as Superintendents, General Foremen, etc., prior to the initiation of construction work at any job site. A written record shall be made and maintained identifying the time and place of these meetings, persons attending, subject matter discussed, and disposition of the subject matter.
- viii. Disseminate the Contractor's EEO policy externally by including it in any advertising in the news media, specifically including minority and female news media, and providing written notification to and discussing the Contractor's EEO policy with other Contractors and Subcontractors with whom the Contractor does or anticipates doing business.
- ix. Direct its recruitment efforts, both oral and written, to minority, female and community organizations, to schools with minority and female students and to minority and female recruitment and training organizations serving the Contractor's recruitment area and employment needs. Not later than one month prior to the date for the acceptance of applications for apprenticeship or other training by any recruitment source, the Contractor shall send written notification to organizations such as the above, describing the openings, screening procedures, and tests to be used in the selection process.
- x. Encourage present minority and female employees to recruit other minority persons and women and, where reasonable, provide after school, summer and vacation employment to minority and female youth both on the site and in other areas of a Contractor's work force.
- xi. Validate all tests and other selection requirements where there is an obligation to do so under 41 CFR part 60-3.
- xii. Conduct, at least annually, an inventory and evaluation at least of all minority and female personnel for promotional opportunities and encourage these employees to seek or to prepare for, through appropriate training, etc., such opportunities.
- xiii. Ensure that seniority practices, job classifications, work assignments and other personnel practices, do not have a discriminatory effect by continually monitoring all personnel and employment related activities to ensure that the EEO policy and the Contractor's obligations under these specifications are being carried out.
- xiv. Ensure that all facilities and company activities are non-segregated except that separate or single- user toilet and necessary changing facilities shall be provided to assure privacy between the sexes.

- xv. Document and maintain a record of all solicitations of offers for subcontracts from minority and female construction contractors and suppliers, including circulation of solicitations to minority and female contractor associations and other business associations.
 - xvi. Conduct a review, at least annually, of all supervisors' adherence to and performance under the Contractor's EEO policies and affirmative action obligations.
- F. Contractors are encouraged to participate in voluntary associations which assist in fulfilling one or more of their affirmative action obligations (5a through n). The efforts of a contractor association, joint contractor-union, contractor-community, or other similar group of which the contractor is a member and participant, may be asserted as fulfilling any one or more of its obligations under 5a through n of these Specifications provided that the contractor actively participates in the group, makes every effort to assure that the group has a positive impact on the employment of minorities and women in the industry, ensures that the concrete benefits of the program are reflected in the Contractor's minority and female workforce participation and can provide access to documentation which demonstrates the effectiveness of actions taken on behalf of the Contractor. The obligation to comply, however, is the Contractor's and failure of such a group to fulfill an obligation shall not be a defense for the Contractor's noncompliance.
- G. The Contractor is required to provide equal employment opportunity and to take affirmative action for all minority groups, both male and female, and all women, both minority and non-minority. Consequently, the Contractor may be in violation of the Executive Order if a particular group is employed in a substantially disparate manner.
- H. The Contractor shall not use the goals and timetables or affirmative action standards to discriminate against any person because of race, color, religion, sex, sexual orientation, gender identity, or national origin.
- I. The Contractor shall not enter into any Subcontract with any person or firm debarred from Government contracts pursuant to Executive Order 11246.
- J. The Contractor shall carry out such sanctions and penalties for violation of these specifications and of the Equal Opportunity Clause, including suspension, termination and cancellation of existing subcontracts as may be imposed or ordered pursuant to Executive Order 11246, as amended, and its implementing regulations, by the Office of Federal Contract Compliance Programs. Any Contractor who fails to carry out such sanctions and penalties shall be in violation of these specifications and Executive Order 11246, as amended.
- K. The Contractor, in fulfilling its obligations under these specifications, shall implement specific affirmative action steps, at least as extensive as those standards prescribed in paragraph 7 of these specifications, so as to achieve maximum results from its efforts to ensure equal employment opportunity. If the Contractor fails to comply with the requirements of the Executive Order, the implementing regulations, or these specifications, the Director shall proceed in accordance with 41 CFR 60-4.8.

- L. The Contractor shall designate a responsible official to monitor all employment related activity to ensure that the company EEO policy is being carried out, to submit reports relating to the provisions hereof as may be required by the Government and to keep records. Records shall at least include for each employee the name, address, telephone numbers, construction trade, union affiliation if any, employee identification number when assigned, social security number, race, sex, status (e.g., mechanic, apprentice trainee, helper, or laborer), dates of changes in status, hours worked per week in the indicated trade, rate of pay, and locations at which the work was performed. Records shall be maintained in an easily understandable and retrievable form; however, to the degree that existing records satisfy this requirement, contractors shall not be required to maintain separate records.
- M. Nothing herein provided shall be construed as a limitation upon the application of other laws which establish different standards of compliance or upon the application of requirements for the hiring of local or other area residents (e.g., those under the Public Works Employment Act of 1977 and the Community Development Block Grant Program).

6. Segregated Facilities. (41 CFR 60-1.8).

- A. The contractor must ensure that facilities provided for employees are provided in such a manner that segregation on the basis of race, color, religion, sex, sexual orientation, gender identity, or national origin cannot result. The contractor may neither require such segregated use by written or oral policies nor tolerate such use by employee custom. The contractor's obligation extends further to ensuring that its employees are not assigned to perform their services at any location, under the contractor's control, where the facilities are segregated. This obligation extends to all contracts containing the equal opportunity clause regardless of the amount of the contract. The term "facilities," as used in this section, means waiting rooms, work areas, restaurants and other eating areas, time clocks, restrooms, wash rooms, locker rooms, and other storage or dressing areas, parking lots, drinking fountains, recreation or entertainment areas, transportation, and housing provided for employees; Provided, that separate or single-user restrooms and necessary dressing or sleeping areas shall be provided to assure privacy between the sexes.
- B. Goals can be found at: <https://www.dol.gov/agencies/ofcccp/construction>
- C. Nationwide goal for all covered areas

- 7. AMERICAN IRON AND STEEL (AIS) REQUIREMENT.** The Contractor acknowledges to and for the benefit of the City ("Purchaser") and the United States Army Corps of Engineers ("the Corps") that it understands the goods and services under this Agreement are being funded with monies made available by the Water Infrastructure Finance and Innovation Act program of the Corps that has statutory requirements commonly known as "American Iron and Steel" that requires all of the iron and steel products used in the project to be produced in the United States ("American Iron and Steel Requirement") including iron and steel products provided by the Contractor pursuant to this Agreement. The Contractor hereby represents, warrants and covenants to and for the benefit of the Purchaser and the Corps that (a) the Contractor has reviewed and understands the American Iron and Steel Requirement, (b) all of the iron and steel products used in the project will be and/or have been produced in the United States in a

manner that complies with the American Iron and Steel Requirement, unless a waiver of the requirement is approved, and (c) the Contractor will provide any further verified information, certification or assurance of compliance with this paragraph, or information necessary to support a waiver of the American Iron and Steel Requirement, as may be requested by the Purchaser or the Corps. Notwithstanding any other provision of this Agreement, any failure to comply with this paragraph by the Contractor shall permit the Purchaser or the Corps to recover as damages against the Contractor any loss, expense, or cost (including without limitation attorney's fees) incurred by the Purchaser or the Corps resulting from any such failure (including without limitation any impairment or loss of funding, whether in whole or in part, from the Corps or any damages owed to the Corps by the Purchaser). While the Contractor has no direct contractual privity with the Corps, as a lender to the Purchaser for the funding of its project, the Purchaser and the Contractor agree that the Corps is a third-party beneficiary and neither this paragraph (nor any other provision of this Agreement necessary to give this paragraph force or effect) shall be amended or waived without the prior written consent of the Corps.

8. Compliance with Davis-Bacon and Related Acts.

A. In any contract in excess of \$2,000 which is entered into for the actual construction, alteration and/ or repair, including painting and decorating, of a public building or public work, or building or work financed in whole or in part from Federal funds or in accordance with guarantees of a Federal agency or financed from funds obtained by pledge of any contract of a Federal agency to make a loan, grant or annual contribution (except where a different meaning is expressly indicated), and which is subject to the labor standards provisions of any of the acts listed in 29 C.F.R. § 5.1, the following clauses (or any modifications thereof to meet the particular needs of the agency, provided that such modifications are first approved by the Department of Labor):

i. Minimum wages.

a. All laborers and mechanics employed or working upon the site of the work (or under the United States Housing Act of 1937 or under the Housing Act of 1949 in the construction or development of the project), will be paid unconditionally and not less often than once a week, and without subsequent deduction or rebate on any account (except such payroll deductions as are permitted by regulations issued by the Secretary of Labor under the Copeland Act (29 CFR part 3)), the full amount of wages and bona fide fringe benefits (or cash equivalents thereof) due at time of payment computed at rates not less than those contained in the wage determination of the Secretary of Labor which is attached hereto and made a part hereof, regardless of any contractual relationship which may be alleged to exist between the contractor and such laborers and mechanics. Contributions made or costs reasonably anticipated for bona fide fringe benefits under section 1(b)(2) of the Davis-Bacon Act on behalf of laborers or mechanics are considered wages paid to such laborers or mechanics, subject to the provisions of paragraph (a)(1)(iv) of this section; also, regular contributions made or costs incurred for more than a weekly period (but not less often than quarterly) under plans, funds, or programs which cover the particular weekly period, are deemed to be constructively made or incurred during such weekly period. Such laborers and mechanics shall be paid

the appropriate wage rate and fringe benefits on the wage determination for the classification of work actually performed, without regard to skill, except as provided in §5.5(a)(4). Laborers or mechanics performing work in more than one classification may be compensated at the rate specified for each classification for the time actually worked therein: Provided that the employer's payroll records accurately set forth the time spent in each classification in which work is performed. The wage determination (including any additional classification and wage rates conformed under paragraph (a)(1)(ii) of this section) and the Davis-Bacon poster (WH-1321) shall be posted at all times by the contractor and its subcontractors at the site of the work in a prominent and accessible place where it can be easily seen by the workers.

- b. The CWIFP assistance recipient, City of Ann Arbor, on behalf of the U.S. Army Corps of Engineers (Corps), shall require that any class of laborers or mechanics, including helpers, which is not listed in the wage determination and which is to be employed under the contract shall be classified in conformance with the wage determination. The CWIFP assistance recipient shall approve an additional classification and wage rate and fringe benefits therefore only when the following criteria have been met:
 - 1) The work to be performed by the classification requested is not performed by a classification in the wage determination; and
 - 2) The classification is utilized in the area by the construction industry; and
 - 3) The proposed wage rate, including any bona fide fringe benefits, bears a reasonable relationship to the wage rates contained in the wage determination.
- c. The CWIFP assistance recipient, City of Ann Arbor, on behalf of the U.S. Army Corps of Engineers (Corps), shall require that any class of laborers or mechanics, including helpers, which is not listed in the wage determination and which is to be employed under the contract shall be classified in conformance with the wage determination. The
- d. If the contractor and the laborers and mechanics to be employed in the classification (if known), or their representatives, and the CWIFP assistance recipient agree on the classification and wage rate (including the amount designated for fringe benefits where appropriate), a report of the action taken shall be sent to the Administrator of the Wage and Hour Division (WHD Administrator), U.S. Department of Labor, Washington, DC 20210. The WHD Administrator, or an authorized representative, will approve, modify, or disapprove every additional classification action within 30 days of receipt and so advise the CWIFP assistance recipient or will notify the CWIFP assistance recipient within the 30- day period that additional time is necessary.
- e. In the event the contractor, the laborers or mechanics to be employed in the classification or their representatives, and the CWIFP assistance recipient do not agree on the proposed classification and wage rate (including the amount

designated for fringe benefits, where appropriate), the CWIFP assistance recipient shall refer the questions, including the views of all interested parties and the recommendation of the CWIFP assistance recipient, to the WHD Administrator for determination. The WHD Administrator, or an authorized representative, will issue a determination within 30 days of receipt and so advise the CWIFP assistance recipient or will notify the CWIFP assistance recipient within the 30-day period that additional time is necessary.

- f. The wage rate (including fringe benefits where appropriate) determined pursuant to paragraphs (a)(1)(ii) (B) or (C) of this section, shall be paid to all workers performing work in the classification under this contract from the first day on which work is performed in the classification.
 - ii. Whenever the minimum wage rate prescribed in the contract for a class of laborers or mechanics includes a fringe benefit which is not expressed as an hourly rate, the contractor shall either pay the benefit as stated in the wage determination or shall pay another bona fide fringe benefit or an hourly cash equivalent thereof. If the contractor does not make payments to a trustee or other third person, the contractor may consider part of the wages of any laborer or mechanic the amount of any costs reasonably anticipated in providing bona fide fringe benefits under a plan or program, Provided, That the Secretary of Labor has found, upon the written request of the contractor, that the applicable standards of the Davis-Bacon Act have been met. The Secretary of Labor may require the contractor to set aside in a separate account assets for the meeting of obligations under the plan or program.
- B. Withholding. The City, shall upon written request of the CWIFP Director or an authorized representative of the Department of Labor withhold or cause to be withheld from the contractor under this contract or any other Federal contract with the same prime contractor, or any other federally-assisted contract subject to Davis-Bacon prevailing wage requirements, which is held by the same prime contractor, so much of the accrued payments or advances as may be considered necessary to pay laborers and mechanics, including apprentices, trainees, and helpers, employed by the contractor or any subcontractor the full amount of wages required by the contract. In the event of failure to pay any laborer or mechanic, including any apprentice, trainee, or helper, employed or working on the site of the work (or under the United States Housing Act of 1937 or under the Housing Act of 1949 in the construction or development of the project), all or part of the wages required by the contract, the CWIFP Director may, after written notice to the contractor, sponsor, applicant, or owner, take such action as may be necessary to cause the suspension of any further payment, advance, or guarantee of funds until such violations have ceased.
- C. Payrolls and basic records.
- i. Payrolls and basic records relating thereto shall be maintained by the contractor during the course of the work and preserved for a period of three years thereafter for all laborers and mechanics working at the site of the work (or under the United States Housing Act of 1937, or under the Housing Act of 1949, in the construction or development of the project). Such records shall contain the name, address, and

social security number of each such worker, his or her correct classification, hourly rates of wages paid (including rates of contributions or costs anticipated for bona fide fringe benefits or cash equivalents thereof of the types described in section 1(b)(2)(B) of the Davis-Bacon Act), daily and weekly number of hours worked, deductions made, and actual wages paid. Whenever the Secretary of Labor has found under 29 CFR 5.5(a)(1)(iv) that the wages of any laborer or mechanic include the amount of any costs reasonably anticipated in providing benefits under a plan or program described in section 1(b)(2)(B) of the Davis-Bacon Act, the contractor shall maintain records which show that the commitment to provide such benefits is enforceable, that the plan or program is financially responsible, and that the plan or program has been communicated in writing to the laborers or mechanics affected, and records which show the costs anticipated or the actual cost incurred in providing such benefits. Contractors employing apprentices or trainees under approved programs shall maintain written evidence of the registration of apprenticeship programs and certification of trainee programs, the registration of the apprentices and trainees, and the ratios and wage rates prescribed in the applicable programs.

- ii. The contractor shall submit weekly for each week in which any contract work is performed a copy of all payrolls to the City. The payrolls submitted shall set out accurately and completely all of the information required to be maintained under 29 CFR 5.5(a)(3) (i), except that full social security numbers and home addresses shall not be included on weekly transmittals. Instead the payrolls shall only need to include an individually identifying number for each employee (e.g., the last four digits of the employee's social security number). The required weekly payroll information may be submitted in any form desired. Optional Form WH-347 is available for this purpose from the Wage and Hour Division Website at <https://www.dol.gov/agencies/whd/forms/wh347> or its successor site. The prime contractor is responsible for the submission of copies of payrolls by all subcontractors. Contractors and subcontractors shall maintain the full social security number and current address of each covered worker, and shall provide them upon request to the City, for transmission to the Corps, the contractor, or the Wage and Hour Division of the Department of Labor for purposes of an investigation or audit of compliance with prevailing wage requirements. It is not a violation of this section for a prime contractor to require a subcontractor to provide addresses and social security numbers to the prime contractor for its own records, without weekly submission to the City.
- iii. Each payroll submitted shall be accompanied by a "Statement of Compliance," signed by the contractor or subcontractor or his or her agent who pays or supervises the payment of the persons employed under the contract and shall certify the following:
 - a. That the payroll for the payroll period contains the information required to be provided under §5.5(a)(3)(ii) of Regulations, 29 CFR part 5, the appropriate information is being maintained under §5.5(a)(3)(i) of Regulations, 29 CFR part 5, and that such information is correct and complete;
 - b. That each laborer or mechanic (including each helper, apprentice, and trainee) employed on the contract during the payroll period has been paid the full weekly wages earned, without rebate, either directly or indirectly, and that no deductions

have been made either directly or indirectly from the full wages earned, other than permissible deductions as set forth in Regulations, 29 CFR part 3;

- c. That each laborer or mechanic has been paid not less than the applicable wage rates and fringe benefits or cash equivalents for the classification of work performed, as specified in the applicable wage determination incorporated into the contract.
 - iv. The weekly submission of a properly executed certification set forth on the reverse side of Optional Form WH-347 shall satisfy the requirement for submission of the "Statement of Compliance" required by paragraph (a)(3)(ii)(B) of this section.
 - v. The falsification of any of the above certifications may subject the contractor or subcontractor to civil or criminal prosecution under section 1001 of title 18 and section 231 of title 31 of the United States Code.
- D. The contractor or subcontractor shall make the records required under paragraph (a) (3)(i) of this section available for inspection, copying, or transcription by authorized representatives of [name of the borrower, Corps, or the Department of Labor, and shall permit such representatives to interview employees during working hours on the job. If the contractor or subcontractor fails to submit the required records or to make them available, the Corps may, after written notice to the City of Ann Arbor, take such action as may be necessary to cause the suspension of any further payment, advance, or guarantee of funds. Furthermore, failure to submit the required records upon request or to make such records available may be grounds for debarment action pursuant to 29 CFR 5.12.
- E. Apprentices and trainees
- i. Apprentices. Apprentices will be permitted to work at less than the predetermined rate for the work they performed when they are employed pursuant to and individually registered in a bona fide apprenticeship program registered with the U.S. Department of Labor, Employment and Training Administration, Office of Apprenticeship Training, Employer and Labor Services, or with a State Apprenticeship Agency recognized by the Office, or if a person is employed in his or her first 90 days of probationary employment as an apprentice in such an apprenticeship program, who is not individually registered in the program, but who has been certified by the Office of Apprenticeship Training, Employer and Labor Services or a State Apprenticeship Agency (where appropriate) to be eligible for probationary employment as an apprentice. The allowable ratio of apprentices to journeymen on the job site in any craft classification shall not be greater than the ratio permitted to the contractor as to the entire work force under the registered program. Any worker listed on a payroll at an apprentice wage rate, who is not registered or otherwise employed as stated above, shall be paid not less than the applicable wage rate on the wage determination for the classification of work actually performed. In addition, any apprentice performing work on the job site in excess of the ratio permitted under the registered program shall be paid not less than the applicable wage rate on the wage determination for the work actually performed. Where a contractor is performing construction on a project in a locality other than that in which its program is registered, the ratios and wage rates (expressed in percentages of the journeyman's hourly rate) specified in the contractor's or

subcontractor's registered program shall be observed. Every apprentice must be paid at not less than the rate specified in the registered program for the apprentice's level of progress, expressed as a percentage of the journeymen hourly rate specified in the applicable wage determination. Apprentices shall be paid fringe benefits in accordance with the provisions of the apprenticeship program. If the apprenticeship program does not specify fringe benefits, apprentices must be paid the full amount of fringe benefits listed on the wage determination for the applicable classification. If the WHD Administrator determines that a different practice prevails for the applicable apprentice classification, fringes shall be paid in accordance with that determination. In the event the Office of Apprenticeship Training, Employer and Labor Services, or a State Apprenticeship Agency recognized by the Office, withdraws approval of an apprenticeship program, the contractor will no longer be permitted to utilize apprentices at less than the applicable predetermined rate for the work performed until an acceptable program is approved.

- ii. Trainees. Except as provided in 29 CFR 5.16, trainees will not be permitted to work at less than the predetermined rate for the work performed unless they are employed pursuant to and individually registered in a program which has received prior approval, evidenced by formal certification by the U.S. Department of Labor, Employment and Training Administration. The ratio of trainees to journeymen on the job site shall not be greater than permitted under the plan approved by the Employment and Training Administration. Every trainee must be paid at not less than the rate specified in the approved program for the trainee's level of progress, expressed as a percentage of the journeyman hourly rate specified in the applicable wage determination. Trainees shall be paid fringe benefits in accordance with the provisions of the trainee program. If the trainee program does not mention fringe benefits, trainees shall be paid the full amount of fringe benefits listed on the wage determination unless the WHD Administrator determines that there is an apprenticeship program associated with the corresponding journeyman wage rate on the wage determination which provides for less than full fringe benefits for apprentices. Any employee listed on the payroll at a trainee rate who is not registered and participating in a training plan approved by the Employment and Training Administration shall be paid not less than the applicable wage rate on the wage determination for the classification of work actually performed. In addition, any trainee performing work on the job site in excess of the ratio permitted under the registered program shall be paid not less than the applicable wage rate on the wage determination for the work actually performed. In the event the Employment and Training Administration withdraws approval of a training program, the contractor will no longer be permitted to utilize trainees at less than the applicable predetermined rate for the work performed until an acceptable program is approved.
- iii. Equal employment opportunity. The utilization of apprentices, trainees and journeymen under this part shall be in conformity with the equal employment opportunity requirements of Executive Order 11246, as amended, and 29 CFR part 30.

F. Compliance with Copeland Act requirements. The contractor shall comply with the requirements of 29 CFR part which are incorporated by reference in this contract.

G. Subcontracts. The contractor or subcontractor shall insert in any subcontracts the clauses contained in 29 CFR 5.5(a)(1) through (10) and such other clauses as the EPA may by appropriate instructions require, and also a clause requiring the subcontractors to include

these clauses in any lower tier subcontracts. The prime contractor shall be responsible for the compliance by any subcontractor or lower tier subcontractor with all the contract clauses in 29 CFR 5.5.

- H. Contract termination: debarment. A breach of the contract clauses in 29 CFR 5.5 may be grounds for termination of the contract, and for debarment as a contractor and a subcontractor as provided in 29 CFR 5.12.
- I. Compliance with Davis-Bacon and Related Act requirements. All rulings and interpretations of the Davis-Bacon and Related Acts contained in 29 CFR parts 1, 3, and 5 are herein incorporated by reference in this contract.
- J. Disputes concerning labor standards. Disputes arising out of the labor standards provisions of this contract shall not be subject to the general disputes clause of this contract. Such disputes shall be resolved in accordance with the procedures of the Department of Labor set forth in 29 CFR parts 5, 6, and 7. Disputes within the meaning of this clause include disputes between the contractor (or any of its subcontractors) and City of Ann Arbor, Corps, the U.S. Department of Labor, or the employees or their representatives.
- K. Certification of eligibility.
 - i. By entering into this contract, the contractor certifies that neither it (nor he or she) nor any person or firm who has an interest in the contractor's firm is a person or firm ineligible to be awarded Government contracts by virtue of section 3(a) of the Davis-Bacon Act or 29 CFR 5.12(a)(1).
 - ii. No part of this contract shall be subcontracted to any person or firm ineligible for award of a Government contract by virtue of section 3(a) of the Davis-Bacon Act or 29 CFR 5.12(a)(1).
 - iii. The penalty for making false statements is prescribed in the U.S. Criminal Code, 18 U.S.C. 1001.

9. **Contract Work Hours and Safety Standards Act.** The following clauses set forth in paragraphs (b)(1), (2), (3), and (4) of this section shall be inserted in full in any contract in an amount in excess of \$100,000 and subject to the overtime provisions of the Contract Work Hours and Safety Standards Act. These clauses shall be inserted in addition to the clauses required by § 5.5(a) or § 4.6 of part 4 of this title. As used in this paragraph, the terms laborers and mechanics include watchmen and guards.

- A. Overtime requirements. No contractor or subcontractor contracting for any part of the contract work which may require or involve the employment of laborers or mechanics shall require or permit any such laborer or mechanic in any workweek in which he or she is employed on such work to work in excess of forty hours in such workweek unless such laborer or mechanic receives compensation at a rate not less than one and one-half times the basic rate of pay for all hours worked in excess of forty hours in such workweek.

- B. Violation; liability for unpaid wages; liquidated damages. In the event of any violation of the clause set forth in paragraph (b)(1) of this section the contractor and any subcontractor responsible therefor shall be liable for the unpaid wages. In addition, such contractor and subcontractor shall be liable to the United States (in the case of work done under contract for the District of Columbia or a territory, to such District or to such territory), for liquidated damages. Such liquidated damages shall be computed with respect to each individual laborer or mechanic, including watchmen and guards, employed in violation of the clause set forth in paragraph (b)(1) of this section, in the sum of \$25 for each calendar day on which such individual was required or permitted to work in excess of the standard workweek of forty hours without payment of the overtime wages required by the clause set forth in paragraph (b)(1) of this section.
- C. Withholding for unpaid wages and liquidated damages. The City shall upon its own action or upon written request of an authorized representative of the Department of Labor, or the Corps, withhold or cause to be withheld, from any moneys payable on account of work performed by the contractor or subcontractor under any such contract or any other Federal contract with the same prime contractor, or any other federally-assisted contract subject to the Contract Work Hours and Safety Standards Act, which is held by the same prime contractor, such sums as may be determined to be necessary to satisfy any liabilities of such contractor or subcontractor for unpaid wages and liquidated damages as provided in the clause set forth in paragraph (b)(2) of this section.
- D. Subcontracts. The contractor or subcontractor shall insert in any subcontracts the clauses set forth in paragraph (b)(1) through (4) of this section and also a clause requiring the subcontractors to include these clauses in any lower tier subcontracts. The prime contractor shall be responsible for compliance by any subcontractor or lower tier subcontractor with the clauses set forth in paragraphs (b)(1) through (4) of this section.
- E. In addition to the clauses contained in paragraph (b), in any contract subject only to the Contract Work Hours and Safety Standards Act and not to any of the other statutes cited in § 5.1, the contractor or subcontractor shall maintain payrolls and basic payroll records during the course of the work and shall preserve them for a period of three years from the completion of the contract for all laborers and mechanics, including guards and watchmen, working on the contract. Such records shall contain the name and address of each such employee, social security number, correct classifications, hourly rates of wages paid, daily and weekly number of hours worked, deductions made, and actual wages paid. Further, the EPA shall cause or require the City of Ann Arbor to insert in any such contract a clause providing that the records to be maintained under this paragraph shall be made available by the contractor or subcontractor for inspection, copying, or transcription by authorized representatives of the City, Corps and the Department of Labor, and the contractor or subcontractor will permit such representatives to interview employees during working hours on the job.

10. Build America, Buy America.

- A. The Contractor acknowledges to and for the benefit of (“Purchaser”) and the United States Army Corps of Engineers (“Corps”) that it understands the goods and services under this Agreement are being funded with federal monies made available by the Corps Water

Infrastructure Financing Program that have statutory requirements commonly known as “Build America, Buy America;” that requires all of the iron and steel, manufactured products, and construction materials used in the project to be produced in the United States (“Build America, Buy America Requirements”) including iron and steel, manufactured products, and construction materials provided by the Contactor pursuant to this Agreement. The Contractor hereby represents and warrants to and for the benefit of the Purchaser and Funding Authority:

- i. The Contractor has reviewed and understands the Build America, Buy America Requirements,
- ii. All of the iron and steel, manufactured products, and construction materials used in the project will be and/or have been produced in the United States in a manner that complies with the Build America, Buy America Requirements, unless a waiver of the requirements is approved, and
- iii. The Contractor will provide any further verified information, certification or assurance of compliance with this paragraph, or information necessary to support a waiver of the Build America, Buy America Requirements, as may be requested by the Purchaser or the Funding Authority. Notwithstanding any other provision of this Agreement, any failure to comply with this paragraph by the Contractor shall permit the Purchaser or Funding Authority to recover as damages against the Contractor any loss, expense, or cost (including without limitation attorney’s fees) incurred by the Purchaser or Funding Authority resulting from any such failure (including without limitation any impairment or loss of funding, whether in whole or in part, from the Funding Authority or any damages owed to the Funding Authority by the Owner). If the Contractor has no direct contractual privity with the Funding Authority, as a lender or awardee to the Purchaser for the funding of its project, the Purchaser and the Contractor agree that the Funding Authority is a third-party beneficiary and neither this paragraph (nor any other provision of this Agreement necessary to give this paragraph force or effect) shall be amended or waived without the prior written consent of the Funding Authority.

11. Prohibition on Certain Telecommunications and Video Surveillance Services or Equipment.

- A. The John S. McCain National Defense Authorization Act for Fiscal Year 2019 (P.L. 115-232), at Section 889, prohibits the Corps financial assistance recipients, including CWIFP borrowers, from expending loan funds to procure or obtain; extend or renew a contract to procure or obtain; or enter into a contract (or extend or renew a contract) to procure or obtain equipment, services, or systems that use covered telecommunications equipment or services as a substantial or essential component of any system, or as critical technology as part of any system. As described in the Act, “covered telecommunications equipment or services” means:
 - i. Telecommunications equipment produced by Huawei Technologies Company or ZTE Corporation (or any subsidiary or affiliate of such entities).
 - ii. For the purpose of public safety, security of government facilities, physical security surveillance of critical infrastructure, and other national security purposes, video

surveillance and telecommunications equipment produced by Hytera Communications Corporation, Hangzhou Hikvision Digital Technology Company, or Dahua Technology Company (or any subsidiary or affiliate of such entities).

- iii. Telecommunications or video surveillance services provided by such entities or using such equipment.
- iv. Telecommunications or video surveillance equipment or services produced or provided by an entity that the Secretary of Defense, in consultation with the Director of the National Intelligence or the Director of the Federal Bureau of Investigation, reasonably believes to be an entity owned or controlled by, or otherwise connected to, the government of a covered foreign country.

B. The Act does not prohibit:

- i. Procuring with an entity to provide a service that connects to the facilities of a third-party, such as backhaul, roaming, or interconnection arrangements.
- ii. Telecommunications equipment that cannot route or redirect user data traffic or permit visibility into any user data or packets that such equipment transmits or otherwise handles.

ATTACHMENT 1

**CITY OF ANN ARBOR
CORPS WATER INFRASTRUCTURE FINANCING PROGRAM (CWIFP)**

CERTIFICATION REGARDING LOBBYING

The undersigned certifies, to the best of the undersigned's knowledge and belief, that:

1. No Federal appropriated funds have been paid or will be paid, by or on behalf of the undersigned, to any person for influencing or attempting to influence an officer or employee of an agency, a Member of Congress, an officer or employee of Congress, or an employee of a Member of Congress in connection with the awarding of any Federal contract, the making of any Federal grant, the making of any Federal loan, the entering into of any cooperative agreement, or the extension, continuation, renewal, amendment, or modification of any Federal contract, grant, loan, or cooperative agreement.
2. If any funds other than Federal appropriated funds have been paid or will be paid to any person for influencing or attempting to influence an officer or employee of any agency, a Member of Congress, an officer or employee of Congress, or an employee of a Member of Congress in connection with this Federal contract, grant, loan, or cooperative agreement, the undersigned shall complete and submit Standard Form-LLL, "Disclosure Form to Report Lobbying," in accordance with its instructions.
3. The undersigned shall require that the language of this certification be included in the award documents for all subawards at all tiers (including subcontracts, subgrants, and contracts under grants, loans, and cooperative agreements) and that all subrecipients shall certify and disclose accordingly.

This certification is a material representation of fact upon which reliance was placed when this transaction was made or entered into. Submission of this certification is a prerequisite for making or entering into this transaction imposed by Section 1352, Title 31 of the U.S. Code. Any person who fails to file the required certification shall be subject to a civil penalty of not less than \$10,000 and not more than \$100,000 for each such failure.

The Contractor, _____, certifies and affirms the truthfulness and accuracy of each statement of its certification and disclosure, if any. In addition, the Contractor understands and agrees that the provisions of 31 U.S.C. Chapter 38, Administrative Remedies for False Claims and Statements, apply to this certification and disclosure, if any.

Signature of Contractor's Authorized Official

Name and Title of Contractor's Authorized Official

Date

ATTACHMENT 2

**CITY OF ANN ARBOR
CORPS WATER INFRASTRUCTURE FINANCING PROGRAM (CWIFP)**

**CERTIFICATION REGARDING DEBARMENT,
SUSPENSION AND OTHER RESPONSIBILITY MATTERS**

The undersigned bidder, proposer, contractor, or subcontractor, as appropriate, certifies to the best of its knowledge and belief that neither it nor any of its officers, directors, or managers who will be working under the Contract, or persons or entities holding a greater than 10% equity interest in it (collectively "Principals"):

1. Are presently debarred, suspended, proposed for debarment, declared ineligible, or voluntarily excluded from covered transactions by any federal or state department or agency in the United States;
2. Have within a three-year period preceding this proposal, bid, or agreement been convicted of or had a civil judgment rendered against them for commission of fraud or a criminal offense in connection with obtaining, attempting to obtain, or performing a public (federal, state or local) transaction or contract under a public transaction; violation of federal or state anti-trust or procurement statutes or commission of embezzlement, theft, forgery, bribery, falsification or destruction of records, making false statements, or receiving stolen property;
3. Are presently indicted for or otherwise criminally or civilly charged by a government entity, (federal, state or local) with commission of any of the offenses enumerated in paragraph 2 of this certification; and
4. Have within a three-year period preceding this application/proposal had one or more public transactions (federal, state or local) terminated for cause or default.

The undersigned bidder, proposer, contractor, or subcontractor, as appropriate, certifies that they are "Actively" registered with SAM (System for Award Management) and have been assigned the following Unique Entity Identifier (UEI): _____. The undersigned further certifies that it shall not knowingly enter any transaction with any subcontractor, material supplier, or vendor who is debarred, suspended, declared ineligible, or voluntarily excluded from covered transactions by any federal or state department/agency.

I understand that a false statement on this certification may be grounds for rejection of this proposal or bid, or termination of the award or, in some instances, criminal prosecution.

The Contractor, _____, certifies as stated above:

Signature

Date

Print Title and Name of authorized representative

I am unable to certify to one or more the above statements. Attached is my explanation.

Signature

Date

Print Title and Name of authorized representative

ATTACHMENT 3

**CITY OF ANN ARBOR
CORPS WATER INFRASTRUCTURE FINANCING PROGRAM (CWIFP)**

System for Award Management (SAM) record search for Contractor / Subcontractor business name and business principal – (*Printout or Screenshot of Results SAM.gov entity search results*)



U.S. Army Corps of Engineers

Corps Water Infrastructure
Financing Program (CWIFP)

**APPLICABLE
FEDERAL REQUIREMENTS
FOR CWIFP PROJECTS**

NOVEMBER 2023



U.S. ARMY



US Army Corps
of Engineers®



APPENDIX A: CERTIFICATION REGARDING LOBBYING

CERTIFICATION REGARDING LOBBYING

The undersigned certifies, to the best of his or her knowledge and belief that:

(1) No Federal appropriated funds have been paid or will be paid, by or on behalf of the undersigned, to any person for influencing or attempting to influence an officer or employee of any agency, a Member of Congress, an officer or employee of Congress, or an employee of a Member of Congress in connection with the awarding of any Federal contract, the making of any Federal grant, the making of any Federal loan, the entering into of any cooperative agreement, and the extension, continuation, renewal, amendment, or modification of any Federal contract, grant, loan, or cooperative agreement.

(2) If any funds other than Federal appropriated funds have been paid or will be paid to any person for influencing or attempting to influence an officer or employee of any agency, a Member of Congress, an officer or employee of Congress, or an employee of a Member of Congress in connection with this Federal contract, grant, loan, or cooperative agreement, the undersigned shall complete and submit Standard Form LLL, "Disclosure Form to Report Lobbying," in accordance with its instructions.

(3) The undersigned shall require that the language of this certification be included in the award documents for all subawards at all tiers (including subcontracts, subgrants, and contracts under grants, loans, and cooperative agreements) and that all subrecipients shall certify and disclose accordingly.

This certification is a material representation of fact upon which reliance was placed when this transaction was made or entered into. Submission of this certification is a prerequisite for making or entering into this transaction imposed by 31 U.S.C. 1352. Any person who fails to file the required certification shall be subject to a civil penalty of not less than \$10,000 and not more than \$100,000 for each such failure.

[SIGNATURE OF BORROWER'S AUTHORIZED REPRESENTATIVE]

[TYPED NAME]

[TITLE IN FULL]

DATE: _____





APPENDIX B: CWIFP SPECIFICATION PACKAGE AND BID CONTRACT LANGUAGE

Last Updated: April 2023

This is a reference document that provides all necessary contract language for CWIFP funded projects. Please note that some of the contract language in this package is required and must be included verbatim and some is suggested. For Suggested Contract Language, you may use your own language so long as it still ensures that provisions are included to guarantee compliance with the federal requirements.

USACE MAKES NO CLAIMS REGARDING THE LEGALITY OF THE FEDERAL LANGUAGE PROVISIONS WITH RESPECT TO STATE OR LOCAL LAW.

ECONOMIC AND MISCELLANEOUS AUTHORITIES

DEBARMENT AND SUSPENSION AND PROHIBITIONS RELATING TO VIOLATIONS OF CWA AND CAA WITH RESPECT TO FEDERAL CONTRACTS, GRANTS, OR LOANS

Suggested Contract Language:

Debarment and Suspension. Contractor certifies that it will not knowingly enter into a contract with anyone who is ineligible under the 2 CFR part 180 and part 1532 (per Executive Order 12549, 51 FR 6370, February 21, 1986) or who is prohibited under Section 306 of the Clean Air Act or Section 508 of the Clean Water Act to participate in the [Project]. Suspension and debarment information can be accessed at <http://www.sam.gov>. Contractor represents and warrants that it has or will include a term or conditions requiring compliance with this provision in all of its subcontracts under this Agreement.

NEW RESTRICTIONS ON LOBBYING

Suggested Contract Language:

Federal Lobbying Restrictions (31 U.S.C 1352). Recipients of federal financial assistance may not pay any person for influencing or attempting to influence any officer or employee of a federal agency, a member of Congress, an officer or employee of Congress, or an employee of a member of Congress with respect to the award, continuation, renewal, amendment, or modification of a federal grant, loan, or contract. Upon award of this contract, Contractor shall complete and submit to the [Insert Borrower label (i.e. City, County, State)] the Certification Regarding Lobbying (Appendix A) and Disclosure of Lobbying Activities (SF-LLL) form. Contractor shall also require all subcontractors and suppliers of any tier awarded a subcontract over \$100,000 to similarly complete and submit the Certification Regarding Lobbying and Disclosure of Lobbying Activities form.

CIVIL RIGHTS, NONDISCRIMINATION, AND EQUAL EMPLOYMENT OPPORTUNITY AUTHORITIES AGE DISCRIMINATION ACT, SECTION 504 OF THE REHABILITATION ACT, AND TITLE VI OF THE CIVIL RIGHTS ACT OF 1964

Suggested Contract Language:

CIVIL RIGHTS OBLIGATIONS. Contractor shall comply with the following federal non-discrimination requirements:

- a. Title VI of the Civil Rights Act of 1964, which prohibits discrimination based on race, color, and national origin, including limited English proficiency (LEP). (42 U.S.C 2000D, et. seq)
- b. Section 504 of the Rehabilitation Act of 1973, which prohibits discrimination against persons with disabili-





APPENDIX B: CWIFP SPECIFICATION PACKAGE AND BID CONTRACT LANGUAGE

ities. (29 U.S.C. 794, supplemented by EO 11914, 41 FR 17871, April 29, 1976 and EO 11250, 30 FR 13003, October 13, 1965)

- c. The Age Discrimination Act of 1975, which prohibits age discrimination. (42 U.S.C 6101 *et. seq*)

EQUAL EMPLOYMENT OPPORTUNITY

Required Contract Language. Note the requirements include three separate sections to include in contracts: EEO, Standard Federal Equal Employment Opportunity Construction Contract Specifications, and Segregated Facilities. This language must be included verbatim:

Equal Employment Opportunity (EEO). The Contractor shall comply with Executive Order 11246, entitled 'Equal Employment Opportunity,' as amended by Executive Order 11375, and as supplemented in Department of Labor regulations (41 CFR Part 60). (EO 11246, 30 FR 12319, September 28, 1965)

Contractor's compliance with Executive order 11246 shall be based on implementation of the Equal Opportunity Clause, and specific affirmative active obligations required by the Standard Federal Equal Employment Opportunity Construction Contract Specifications, as set forth in 41 CFR Part 60-4.

During the performance of this contract, the contractor agrees as follows:

The contractor will not discriminate against any employee or applicant for employment because of race, color, religion, sex, sexual orientation, gender identity, or national origin. The contractor will take affirmative action to ensure that applicants are employed, and that employees are treated during employment, without regard to their race, color,

religion, sex, sexual orientation, gender identity, or national origin. Such action shall include, but not be limited to the following: employment, upgrading, demotion, or transfer; recruitment or recruitment advertising; layoff or termination; rates of pay or other forms of compensation; and selection for training, including apprenticeship. The contractor agrees to post in conspicuous places, available to employees and applicants for employment, notices to be provided by the contracting officer setting forth the provisions of this nondiscrimination clause.

4. The contractor will, in all solicitations or advancements for employees placed by or on behalf of the contractor, state that all qualified applicants will receive consideration for employment without regard to race, color, religion, sex, sexual orientation, gender identity, or national origin.
5. The contractor will not discharge or in any other manner discriminate against any employee or applicant for employment because such employee or applicant has inquired about, discussed, or disclosed the compensation of the employee or applicant or another employee or applicant. This provision shall not apply to instances in which an employee who has access to the compensation information of other employees or applicants as a part of such employee's essential job functions discloses the compensation of such other employees or applicants to individuals who do not otherwise have access to such information, unless such disclosure is in response to a formal complaint or charge, in furtherance of an investigation, proceeding, hearing, or action, including an investigation conducted by the employer, or is consistent with the contractor's legal duty to furnish information.





APPENDIX B: CWIFP SPECIFICATION PACKAGE AND BID CONTRACT LANGUAGE

6. The contractor will send to each labor union or representative of workers with which he has a collective bargaining agreement or other contract or understanding, a notice, to be provided by the agency contracting officer, advising the labor union or workers' representative of the contractor's commitments under Section 202 of Executive Order No. 11246 of September 24, 1965, and shall post copies of the notice in conspicuous places available to employees and applicants for employment.
7. The contractor will comply with all provisions of Executive Order No. 11246 of Sept. 24, 1965, and of the rules, regulations, and relevant orders of the Secretary of Labor.
8. The contractor will furnish all information and reports required by Executive Order No. 11246 of September 24, 1965, and by the rules, regulations, and orders of the Secretary of Labor, or pursuant thereto, and will permit access to his books, records, and accounts by the contracting agency and the Secretary of Labor for purposes of investigation to ascertain compliance with such rules, regulations, and orders.
9. In the event of the contractor's noncompliance with the nondiscrimination clauses of this contract or with any of such rules, regulations, or orders, this contract may be cancelled, terminated, or suspended in whole or in part and the contractor may be declared ineligible for further Government contracts in accordance with procedures authorized in Executive Order No. 11246 of Sept. 24, 1965, and such other sanctions may be imposed and remedies invoked as provided in Executive Order No. 11246 of September 24, 1965, or by rule, regulation, or order of the Secretary of Labor, or as otherwise provided by law.
10. The contractor will include the provisions of paragraphs (1) through (8) in every subcontract or purchase order unless exempted by rules, regulations, or orders of the Secretary of Labor issued pursuant to Section 204 of Executive Order No. 11246 of September 24, 1965, so that such provisions will be binding upon each subcontractor or vendor. The contractor will take such action with respect to any subcontract or purchase order as may be directed by the Secretary of Labor as a means of enforcing such provisions including sanctions for noncompliance: Provided, however, that in the event the contractor becomes involved in, or is threatened with, litigation with a subcontractor or vendor as a result of such direction, the contractor may request the United States to enter into such litigation to protect the interests of the United States. [Sec. 202 amended by EO 11375 of Oct. 13, 1967, 32 FR 14303, 3 CFR, 1966-1970 Comp., p. 684, EO 12086 of Oct. 5, 1978, 43 FR 46501, 3 CFR, 1978 Comp., p. 230, EO 13665 of April 8, 2014, 79 FR 20749, EO 13672 of July 21, 2014, 79 FR 42971]

Standard Federal Equal Employment Opportunity Construction Contract Specifications. (41 CFR 60-4.3)

1. As used in these specifications:
 - a. "Covered area" means the geographical area described in the solicitation from which this contract resulted;
 - b. "Director" means Director, Office of Federal Contract Compliance Programs, United States Department of Labor, or any person to whom the Director delegates authority;





APPENDIX B: CWIFP SPECIFICATION PACKAGE AND BID CONTRACT LANGUAGE

- c. "Employer identification number" means the Federal Social Security number used on the Employer's Quarterly Federal Tax Return, U.S. Treasury Department Form 941.
 - d. "Minority" includes:
 - i. Black (all persons having origins in any of the Black African racial groups not of Hispanic origin);
 - ii. Hispanic (all persons of Mexican, Puerto Rican, Cuban, Central or South American or other Spanish Culture or origin, regardless of race);
 - iii. Asian and Pacific Islander (all persons having origins in any of the original peoples of the Far East, Southeast Asia, the Indian Subcontinent, or the Pacific Islands); and
 - iv. American Indian or Alaskan Native (all persons having origins in any of the original peoples of North America and maintaining identifiable tribal affiliations through membership and participation or community identification).
2. If the Contractor is participating (pursuant to 41 CFR 60-4.5) in a Hometown Plan approved by the U.S. Department of Labor in the covered area either individually or through an association, its affirmative action obligations on all work in the Plan area (including goals and timetables) shall be in accordance with that Plan for those trades which have unions participating in the Plan. Contractors must be able to demonstrate their participation in and compliance with the provisions of any such Hometown Plan. Each Contractor or Subcontractor participating in an approved Plan is individually required to

comply with its obligations under the EEO clause, and to make a good faith effort to achieve each goal under the Plan in each trade in which it has employees. The overall good faith performance by other Contractors or Subcontractors toward a goal in an approved Plan does not excuse any covered Contractor's or Subcontractor's failure to take good faith efforts to achieve the Plan goals and timetables.

The Contractor shall implement the specific affirmative action standards provided in paragraphs 6 a through n of these specifications. The goals set forth in the solicitation from which this contract resulted are expressed as percentages of the total hours of employment and training of minority and female utilization the Contractor should reasonably be able to achieve in each construction trade in which it has employees in the covered area. Covered Construction contractors performing construction work in geographical areas where they do not have a Federal or federally assisted construction contract shall apply the minority and female goals established for the geographical area where the work is being performed. Goals are published periodically in the Federal Register in notice form, and such notices may be obtained from any Office of Federal Contract Compliance Programs office or from Federal procurement contracting officers. The Contractor is expected to make substantially uniform progress in meeting its goals in each craft during the period specified.

3. Neither the provisions of any collective bargaining agreement, nor the failure by a union with whom the Contractor has a collective bargaining agreement, to refer either minorities or women shall excuse the





APPENDIX B: CWIFP SPECIFICATION PACKAGE AND BID CONTRACT LANGUAGE

Contractor's obligations under these specifications, Executive Order 11246, or the regulations promulgated pursuant thereto.

4. In order for the nonworking training hours of apprentices and trainees to be counted in meeting the goals, such apprentices and trainees must be employed by the Contractor during the training period, and the Contractor must have made a commitment to employ the apprentices and trainees at the completion of their training, subject to the availability of employment opportunities. Trainees must be trained pursuant to training programs approved by the U.S. Department of Labor.
5. The Contractor shall take specific affirmative actions to ensure equal employment opportunity. The evaluation of the Contractor's compliance with these specifications shall be based upon its effort to achieve maximum results from its actions. The Contractor shall document these efforts fully, and shall implement affirmative action steps at least as extensive as the following:
 - a. Ensure and maintain a working environment free of harassment, intimidation, and coercion at all sites, and in all facilities at which the Contractor's employees are assigned to work. The Contractor, where possible, will assign two or more women to each construction project. The Contractor shall specifically ensure that all foremen, superintendents, and other on-site supervisory personnel are aware of and carry out the Contractor's obligation to maintain such a working environment, with specific attention to minority or female individuals working at such sites or in such facilities.
 - b. Establish and maintain a current list of minority and female recruitment sources, provide written notification to minority and female recruitment sources and to community organizations when the Contractor or its unions have employment opportunities available, and maintain a record of the organizations' responses.
 - c. Maintain a current file of the names, addresses and telephone numbers of each minority and female off-the-street applicant and minority or female referral from a union, a recruitment source or community organization and of what action was taken with respect to each such individual. If such individual was sent to the union hiring hall for referral and was not referred back to the Contractor by the union or, if referred, not employed by the Contractor, this shall be documented in the file with the reason therefor, along with whatever additional actions the Contractor may have taken.

Provide immediate written notification to the Director when the union or unions with which the Contractor has a collective bargaining agreement has not referred to the Contractor a minority person or woman sent by the Contractor, or when the Contractor has other information that the union referral process has impeded the Contractor's efforts to meet its obligations.
 - d. Develop on-the-job training opportunities and/or participate in training programs for the area which expressly include minorities and women, including upgrading programs and apprenticeship and trainee programs relevant to the Contractor's employment needs, especially those programs funded or approved by the Department of Labor. The Contractor shall





APPENDIX B: CWIFP SPECIFICATION PACKAGE AND BID CONTRACT LANGUAGE

provide notice of these programs to the sources compiled under 5b above.

- e. Disseminate the Contractor's EEO policy by providing notice of the policy to unions and training programs and requesting their cooperation in assisting the Contractor in meeting its EEO obligations; by including it in any policy manual and collective bargaining agreement; by publicizing it in the company newspaper, annual report, etc.; by specific review of the policy with all management personnel and with all minority and female employees at least once a year; and by posting the company EEO policy on bulletin boards accessible to all employees at each location where construction work is performed.
- f. Review, at least annually, the company's EEO policy and affirmative action obligations under these specifications with all employees having any responsibility for hiring, assignment, layoff, termination or other employment decisions including specific review of these items with onsite supervisory personnel such as Superintendents, General Foremen, etc., prior to the initiation of construction work at any job site. A written record shall be made and maintained identifying the time and place of these meetings, persons attending, subject matter discussed, and disposition of the subject matter.
- g. Disseminate the Contractor's EEO policy externally by including it in any advertising in the news media, specifically including minority and female news media, and providing written notification to and discussing the Contractor's EEO policy with other Contractors and Subcontractors with whom the Contractor does or anticipates doing business.
- h. Direct its recruitment efforts, both oral and written, to minority, female and community organizations, to schools with minority and female students and to minority and female recruitment and training organizations serving the Contractor's recruitment area and employment needs. Not later than one month prior to the date for the acceptance of applications for apprenticeship or other training by any recruitment source, the Contractor shall send written notification to organizations such as the above, describing the openings, screening procedures, and tests to be used in the selection process.
- i. Encourage present minority and female employees to recruit other minority persons and women and, where reasonable, provide after school, summer and vacation employment to minority and female youth both on the site and in other areas of a Contractor's work force.
- j. Validate all tests and other selection requirements where there is an obligation to do so under 41 CFR part 60-3.
- k. Conduct, at least annually, an inventory and evaluation at least of all minority and female personnel for promotional opportunities and encourage these employees to seek or to prepare for, through appropriate training, etc., such opportunities.

Ensure that seniority practices, job classifications, work assignments and other personnel practices, do not have a discriminatory effect by continually monitoring all personnel and employment related activities to ensure that the EEO policy and the Contractor's obligations under these specifications are being carried out.





APPENDIX B: CWIFP SPECIFICATION PACKAGE AND BID CONTRACT LANGUAGE

- l.** Ensure that all facilities and company activities are non-segregated except that separate or single-user toilet and necessary changing facilities shall be provided to assure privacy between the sexes.
 - m.** Document and maintain a record of all solicitations of offers for subcontracts from minority and female construction contractors and suppliers, including circulation of solicitations to minority and female contractor associations and other business associations.
 - n.** Conduct a review, at least annually, of all supervisors' adherence to and performance under the Contractor's EEO policies and affirmative action obligations.
- 6.** Contractors are encouraged to participate in voluntary associations which assist in fulfilling one or more of their affirmative action obligations (5a through n). The efforts of a contractor association, joint contractor-union, contractor-community, or other similar group of which the contractor is a member and participant, may be asserted as fulfilling any one or more of its obligations under 5a through n of these Specifications provided that the contractor actively participates in the group, makes every effort to assure that the group has a positive impact on the employment of minorities and women in the industry, ensures that the concrete benefits of the program are reflected in the Contractor's minority and female workforce participation and can provide access to documentation which demonstrates the effectiveness of actions taken on behalf of the Contractor. The obligation to comply, however, is the Contractor's and failure of such a group to fulfill an obligation shall not be a defense for the Contractor's noncompliance.
- 7.** The Contractor is required to provide equal employment opportunity and to take affirmative action for all minority groups, both male and female, and all women, both minority and non-minority. Consequently, the Contractor may be in violation of the Executive Order if a particular group is employed in a substantially disparate manner.
- 8.** The Contractor shall not use the goals and timetables or affirmative action standards to discriminate against any person because of race, color, religion, sex, sexual orientation, gender identity, or national origin.
- 9.** The Contractor shall not enter into any Subcontract with any person or firm debarred from Government contracts pursuant to Executive Order 11246.
- 10.** The Contractor shall carry out such sanctions and penalties for violation of these specifications and of the Equal Opportunity Clause, including suspension, termination and cancellation of existing subcontracts as may be imposed or ordered pursuant to Executive Order 11246, as amended, and its implementing regulations, by the Office of Federal Contract Compliance Programs. Any Contractor who fails to carry out such sanctions and penalties shall be in violation of these specifications and Executive Order 11246, as amended.
- The Contractor, in fulfilling its obligations under these specifications, shall implement specific affirmative action steps, at least as extensive as those standards prescribed in paragraph 7 of these specifications, so as to achieve maximum results from its efforts to ensure equal employment opportunity. If the Contractor fails to comply with the requirements



APPENDIX B: CWIFP SPECIFICATION PACKAGE AND BID CONTRACT LANGUAGE

of the Executive Order, the implementing regulations, or these specifications, the Director shall proceed in accordance with 41 CFR 60-4.8.

11. The Contractor shall designate a responsible official to monitor all employment related activity to ensure that the company EEO policy is being carried out, to submit reports relating to the provisions hereof as may be required by the Government and to keep records. Records shall at least include for each employee the name, address, telephone numbers, construction trade, union affiliation if any, employee identification number when assigned, social security number, race, sex, status (e.g., mechanic, apprentice trainee, helper, or laborer), dates of changes in status, hours worked per week in the indicated trade, rate of pay, and locations at which the work was performed. Records shall be maintained in an easily understandable and retrievable form; however, to the degree that existing records satisfy this requirement, contractors shall not be required to maintain separate records.
12. Nothing herein provided shall be construed as a limitation upon the application of other laws which establish different standards of compliance or upon the application of requirements for the hiring of local or other area residents (e.g., those under the Public Works Employment Act of 1977 and the Community Development Block Grant Program).

Segregated Facilities. (41 CFR 60-1.8) The contractor must ensure that facilities provided for employees are provided in such a manner that segregation on the basis of race, color, religion, sex, sexual orientation, gender identity, or national origin cannot result. The contractor may neither require such segregated use by written or oral policies nor tolerate such use by employee custom. The contractor's obligation extends further to ensuring

that its employees are not assigned to perform their services at any location, under the contractor's control, where the facilities are segregated. This obligation extends to all contracts containing the equal opportunity clause regardless of the amount of the contract. The term "facilities," as used in this section, means waiting rooms, work areas, restaurants and other eating areas, time clocks, restrooms, wash rooms, locker rooms, and other storage or dressing areas, parking lots, drinking fountains, recreation or entertainment areas, transportation, and housing provided for employees; Provided, That separate or single-user restrooms and necessary dressing or sleeping areas shall be provided to assure privacy between the sexes.

2 Goals can be found at: <https://www.dol.gov/agencies/ofccp/construction>

3 Nationwide goal for all covered areas

AMERICAN IRON AND STEEL (AIS) REQUIREMENT

Suggested Contract Language:

The Contractor acknowledges to and for the benefit of [Insert CWIFP Borrower Name] ("Purchaser") and the United States Army Corps of Engineers ("the Corps") that it understands the goods and services under this Agreement are being funded with monies made available by the Water Infrastructure Finance and Innovation Act program of the Corps that has statutory requirements commonly known as "American Iron and Steel" that requires all of the iron and steel products used in the project to be produced in the United States ("American Iron and Steel Requirement") including iron and steel products provided by the Contractor pursuant to this Agreement. The Contractor hereby represents,





APPENDIX B: CWIFP SPECIFICATION PACKAGE AND BID CONTRACT LANGUAGE

warrants and covenants to and for the benefit of the Purchaser and the Corps that (a) the Contractor has reviewed and understands the American Iron and Steel Requirement, (b) all of the iron and steel products used in the project will be and/or have been produced in the United States in a manner that complies with the American Iron and Steel Requirement, unless a waiver of the requirement is approved, and (c) the Contractor will provide any further verified information, certification or assurance of compliance with this paragraph, or information necessary to support a waiver of the American Iron and Steel Requirement, as may be requested by the Purchaser or the Corps. Notwithstanding any other provision of this Agreement, any failure to comply with this paragraph by the Contractor shall permit the Purchaser or the Corps to recover as damages against the Contractor any loss, expense, or cost (including without limitation attorney's fees) incurred by the Purchaser or the Corps resulting from any such failure (including without limitation any impairment or loss of funding, whether in whole or in part, from the Corps or any damages owed to the Corps by the Purchaser). While the Contractor has no direct contractual privity with the Corps, as a lender to the Purchaser for the funding of its project, the Purchaser and the Contractor agree that the Corps is a third-party beneficiary and neither this paragraph (nor any other provision of this Agreement necessary to give this paragraph force or effect) shall be amended or waived without the prior written consent of the Corps.

LABOR LAWS AND STANDARDS

Note that the language below addresses Davis Bacon and Related Acts and incorporates the CWIFP borrower as an authorized representative, in accordance with the CWIFP loan agreement, to ensure compliance with this federal requirement.

Required Contract Language.

Compliance with Davis-Bacon and Related Acts.

a. In any contract in excess of \$2,000 which is entered into for the actual construction, alteration and/or repair, including painting and decorating, of a public building or public work, or building or work financed in whole or in part from Federal funds or in accordance with guarantees of a Federal agency or financed from funds obtained by pledge of any contract of a Federal agency to make a loan, grant or annual contribution (except where a different meaning is expressly indicated), and which is subject to the labor standards provisions of any of the acts listed in 29 C.F.R. § 5.1, the following clauses (or any modifications thereof to meet the particular needs of the agency, provided that such modifications are first approved by the Department of Labor):

1. Minimum wages.

I. All laborers and mechanics employed or working upon the site of the work (or under the United States Housing Act of 1937 or under the Housing Act of 1949 in the construction or development of the project), will be paid unconditionally and not less often than once a week, and without subsequent deduction or rebate on any account (except such payroll deductions as are permitted by regulations issued by the Secretary of Labor under the Copeland Act (29 CFR part 3)), the full amount of wages and bona fide fringe benefits (or cash equivalents thereof) due at time of payment computed at rates not less than those contained in the wage determination of the Secretary of Labor which is attached hereto and made





APPENDIX B: CWIFP SPECIFICATION PACKAGE AND BID CONTRACT LANGUAGE

a part hereof, regardless of any contractual relationship which may be alleged to exist between the contractor and such laborers and mechanics. Contributions made or costs reasonably anticipated for bona fide fringe benefits under section 1(b)(2) of the Davis-Bacon Act on behalf of laborers or mechanics are considered wages paid to such laborers or mechanics, subject to the provisions of paragraph (a)(1)(iv) of this section; also, regular contributions made or costs incurred for more than a weekly period (but not less often than quarterly) under plans, funds, or programs which cover the particular weekly period, are deemed to be constructively made or incurred during such weekly period. Such laborers and mechanics shall be paid the appropriate wage rate and fringe benefits on the wage determination for the classification of work actually performed, without regard to skill, except as provided in § 5.5(a)(4). Laborers or mechanics performing work in more than one classification may be compensated at the rate specified for each classification for the time actually worked therein: Provided that the employer's payroll records accurately set forth the time spent in each classification in which work is performed. The wage determination (including any additional classification and wage rates conformed under paragraph (a)(1)(ii) of this section) and the Davis-Bacon poster (WH-1321) shall be posted at all times by the contractor and its subcontractors at the site of the work in a prominent and accessible place where it can be easily seen by the workers.

II.

- A.** The CWIFP assistance recipient, [name of CWIFP borrower], on behalf of the U.S. Army Corps of Engineers (Corps), shall require that any class of laborers or mechanics, including helpers, which is not listed in the wage determination and which is to be employed under the contract shall be classified in conformance with the wage determination. The CWIFP assistance recipient shall approve an additional classification and wage rate and fringe benefits therefore only when the following criteria have been met:
- i.** The work to be performed by the classification requested is not performed by a classification in the wage determination; and
 - ii.** The classification is utilized in the area by the construction industry; and
 - iii.** The proposed wage rate, including any bona fide fringe benefits, bears a reasonable relationship to the wage rates contained in the wage determination.
- B.** If the contractor and the laborers and mechanics to be employed in the classification (if known), or their representatives, and the CWIFP assistance recipient agree on the classification and wage rate (including the amount designated for fringe benefits where appropriate), a





APPENDIX B: CWIFP SPECIFICATION PACKAGE AND BID CONTRACT LANGUAGE

report of the action taken shall be sent to the Administrator of the Wage and Hour Division (WHD Administrator), U.S. Department of Labor, Washington, DC 20210. The WHD Administrator, or an authorized representative, will approve, modify, or disapprove every additional classification action within 30 days of receipt and so advise the CWIFP assistance recipient or will notify the CWIFP assistance recipient within the 30-day period that additional time is necessary.

- C. In the event the contractor, the laborers or mechanics to be employed in the classification or their representatives, and the CWIFP assistance recipient do not agree on the proposed classification and wage rate (including the amount designated for fringe benefits, where appropriate), the CWIFP assistance recipient shall refer the questions, including the views of all interested parties and the recommendation of the CWIFP assistance recipient, to the WHD Administrator for determination. The WHD Administrator, or an authorized representative, will issue a determination within 30 days of receipt and so advise the CWIFP assistance recipient or will notify the CWIFP assistance recipient within the 30-day period that additional time is necessary.
- D. The wage rate (including fringe benefits where appropriate) determined pursuant to paragraphs (a)(1)(ii) (B) or (C) of this section, shall be paid to all workers per-

forming work in the classification under this contract from the first day on which work is performed in the classification.

- III. Whenever the minimum wage rate prescribed in the contract for a class of laborers or mechanics includes a fringe benefit which is not expressed as an hourly rate, the contractor shall either pay the benefit as stated in the wage determination or shall pay another bona fide fringe benefit or an hourly cash equivalent thereof. If the contractor does not make payments to a trustee or other third person, the contractor may consider part of the wages of any laborer or mechanic the amount of any costs reasonably anticipated in providing bona fide fringe benefits under a plan or program, Provided, That the Secretary of Labor has found, upon the written request of the contractor, that the applicable standards of the Davis-Bacon Act have been met. The Secretary of Labor may require the contractor to set aside in a separate account assets for the meeting of obligations under the plan or program.
- 2. Withholding. [name of CWIFP borrower], shall upon written request of the CWIFP Director or an authorized representative of the Department of Labor withhold or cause to be withheld from the contractor under this contract or any other Federal contract with the same prime contractor, or any other federally-assisted contract subject to Davis-Bacon prevailing wage requirements, which is held by the same prime contractor, so much of the accrued payments or advances as may be considered necessary to pay laborers and mechanics, including apprentices, trainees,



APPENDIX B: CWIFP SPECIFICATION PACKAGE AND BID CONTRACT LANGUAGE

and helpers, employed by the contractor or any subcontractor the full amount of wages required by the contract. In the event of failure to pay any laborer or mechanic, including any apprentice, trainee, or helper, employed or working on the site of the work (or under the United States Housing Act of 1937 or under the Housing Act of 1949 in the construction or development of the project), all or part of the wages required by the contract, the CWIFP Director may, after written notice to the contractor, sponsor, applicant, or owner, take such action as may be necessary to cause the suspension of any further payment, advance, or guarantee of funds until such violations have ceased.

3. Payrolls and basic records.

I. Payrolls and basic records relating thereto shall be maintained by the contractor during the course of the work and preserved for a period of three years thereafter for all laborers and mechanics working at the site of the work (or under the United States Housing Act of 1937, or under the Housing Act of 1949, in the construction or development of the project). Such records shall contain the name, address, and social security number of each such worker, his or her correct classification, hourly rates of wages paid (including rates of contributions or costs anticipated for bona fide fringe benefits or cash equivalents thereof of the types described in section 1(b)(2)(B) of the Davis-Bacon Act), daily and weekly number of hours worked, deductions made and actual wages paid. Whenever the Secretary of Labor has found under 29 CFR 5.5(a)(1)(iv) that the wages of any laborer or

mechanic include the amount of any costs reasonably anticipated in providing benefits under a plan or program described in section 1(b)(2)(B) of the Davis-Bacon Act, the contractor shall maintain records which show that the commitment to provide such benefits is enforceable, that the plan or program is financially responsible, and that the plan or program has been communicated in writing to the laborers or mechanics affected, and records which show the costs anticipated or the actual cost incurred in providing such benefits. Contractors employing apprentices or trainees under approved programs shall maintain written evidence of the registration of apprenticeship programs and certification of trainee programs, the registration of the apprentices and trainees, and the ratios and wage rates prescribed in the applicable programs.

II.

A. The contractor shall submit weekly for each week in which any contract work is performed a copy of all payrolls to [name of CWIFP borrower]. The payrolls submitted shall set out accurately and completely all of the information required to be maintained under 29 CFR 5.5(a)(3) (i), except that full social security numbers and home addresses shall not be included on weekly transmittals. Instead the payrolls shall only need to include an individually identifying number for each employee (e.g., the last four digits of the employee's social security number). The required weekly payroll information





APPENDIX B: CWIFP SPECIFICATION PACKAGE AND BID CONTRACT LANGUAGE

may be submitted in any form desired. Optional Form WH-347 is available for this purpose from the Wage and Hour Division Website at <https://www.dol.gov/agencies/whd/forms/wh347> or its successor site. The prime contractor is responsible for the submission of copies of payrolls by all subcontractors. Contractors and subcontractors shall maintain the full social security number and current address of each covered worker, and shall provide them upon request to [name of CWIFP borrower], for transmission to the Corps, the contractor, or the Wage and Hour Division of the Department of Labor for purposes of an investigation or audit of compliance with prevailing wage requirements. It is not a violation of this section for a prime contractor to require a subcontractor to provide addresses and social security numbers to the prime contractor for its own records, without weekly submission to [name of CWIFP borrower].

B. Each payroll submitted shall be accompanied by a “Statement of Compliance,” signed by the contractor or subcontractor or his or her agent who pays or supervises the payment of the persons employed under the contract and shall certify the following:

i. That the payroll for the payroll period contains the information required to be provided under § 5.5 (a)(3)(ii) of Regulations, 29 CFR part 5, the appropriate information is being

maintained under § 5.5 (a)(3)(i) of Regulations, 29 CFR part 5, and that such information is correct and complete;

ii. That each laborer or mechanic (including each helper, apprentice, and trainee) employed on the contract during the payroll period has been paid the full weekly wages earned, without rebate, either directly or indirectly, and that no deductions have been made either directly or indirectly from the full wages earned, other than permissible deductions as set forth in Regulations, 29 CFR part 3;

iii. That each laborer or mechanic has been paid not less than the applicable wage rates and fringe benefits or cash equivalents for the classification of work performed, as specified in the applicable wage determination incorporated into the contract.

C. The weekly submission of a properly executed certification set forth on the reverse side of Optional Form WH-347 shall satisfy the requirement for submission of the “Statement of Compliance” required by paragraph (a)(3)(ii)(B) of this section.

D. The falsification of any of the above certifications may subject the contractor or subcontractor to civil or criminal prosecution under section 1001 of title 18 and section 231 of title 31 of the United States Code.





APPENDIX B: CWIFP SPECIFICATION PACKAGE AND BID CONTRACT LANGUAGE

III. The contractor or subcontractor shall make the records required under paragraph (a) (3)(i) of this section available for inspection, copying, or transcription by authorized representatives of [name of the borrower, Corps, or the Department of Labor, and shall permit such representatives to interview employees during working hours on the job. If the contractor or subcontractor fails to submit the required records or to make them available, the Corps may, after written notice to the [name of CWIFP borrower], take such action as may be necessary to cause the suspension of any further payment, advance, or guarantee of funds. Furthermore, failure to submit the required records upon request or to make such records available may be grounds for debarment action pursuant to 29 CFR 5.12.

4. Apprentices and trainees –

I. Apprentices. Apprentices will be permitted to work at less than the predetermined rate for the work they performed when they are employed pursuant to and individually registered in a bona fide apprenticeship program registered with the U.S. Department of Labor, Employment and Training Administration, Office of Apprenticeship Training, Employer and Labor Services, or with a State Apprenticeship Agency recognized by the Office, or if a person is employed in his or her first 90 days of probationary employment as an apprentice in such an apprenticeship program, who is not individually registered in the program, but who has been certified by the Office of Apprenticeship Training, Employer

and Labor Services or a State Apprenticeship Agency (where appropriate) to be eligible for probationary employment as an apprentice. The allowable ratio of apprentices to journeymen on the job site in any craft classification shall not be greater than the ratio permitted to the contractor as to the entire work force under the registered program. Any worker listed on a payroll at an apprentice wage rate, who is not registered or otherwise employed as stated above, shall be paid not less than the applicable wage rate on the wage determination for the classification of work actually performed. In addition, any apprentice performing work on the job site in excess of the ratio permitted under the registered program shall be paid not less than the applicable wage rate on the wage determination for the work actually performed. Where a contractor is performing construction on a project in a locality other than that in which its program is registered, the ratios and wage rates (expressed in percentages of the journeyman's hourly rate) specified in the contractor's or subcontractor's registered program shall be observed. Every apprentice must be paid at not less than the rate specified in the registered program for the apprentice's level of progress, expressed as a percentage of the journeymen hourly rate specified in the applicable wage determination. Apprentices shall be paid fringe benefits in accordance with the provisions of the apprenticeship program. If the apprenticeship program does not specify fringe benefits, apprentices must be paid the full amount of fringe benefits listed on the wage determination for the applicable





APPENDIX B: CWIFP SPECIFICATION PACKAGE AND BID CONTRACT LANGUAGE

classification. If the WHD Administrator determines that a different practice prevails for the applicable apprentice classification, fringes shall be paid in accordance with that determination. In the event the Office of Apprenticeship Training, Employer and Labor Services, or a State Apprenticeship Agency recognized by the Office, withdraws approval of an apprenticeship program, the contractor will no longer be permitted to utilize apprentices at less than the applicable predetermined rate for the work performed until an acceptable program is approved.

- II. Trainees. Except as provided in 29 CFR 5.16, trainees will not be permitted to work at less than the predetermined rate for the work performed unless they are employed pursuant to and individually registered in a program which has received prior approval, evidenced by formal certification by the U.S. Department of Labor, Employment and Training Administration. The ratio of trainees to journeymen on the job site shall not be greater than permitted under the plan approved by the Employment and Training Administration. Every trainee must be paid at not less than the rate specified in the approved program for the trainee's level of progress, expressed as a percentage of the journeyman hourly rate specified in the applicable wage determination. Trainees shall be paid fringe benefits in accordance with the provisions of the trainee program. If the trainee program does not mention fringe benefits, trainees shall be paid the full amount of fringe benefits listed on the wage determination unless the WHD

Administrator determines that there is an apprenticeship program associated with the corresponding journeyman wage rate on the wage determination which provides for less than full fringe benefits for apprentices. Any employee listed on the payroll at a trainee rate who is not registered and participating in a training plan approved by the Employment and Training Administration shall be paid not less than the applicable wage rate on the wage determination for the classification of work actually performed. In addition, any trainee performing work on the job site in excess of the ratio permitted under the registered program shall be paid not less than the applicable wage rate on the wage determination for the work actually performed. In the event the Employment and Training Administration withdraws approval of a training program, the contractor will no longer be permitted to utilize trainees at less than the applicable predetermined rate for the work performed until an acceptable program is approved.

- III. Equal employment opportunity. The utilization of apprentices, trainees and journeymen under this part shall be in conformity with the equal employment opportunity requirements of Executive Order 11246, as amended, and 29 CFR part 30.
5. Compliance with Copeland Act requirements. The contractor shall comply with the requirements of 29 CFR part 3, which are incorporated by reference in this contract.
6. Subcontracts. The contractor or subcontractor shall insert in any subcontracts the clauses con-





APPENDIX B: CWIFP SPECIFICATION PACKAGE AND BID CONTRACT LANGUAGE

tained in 29 CFR 5.5(a)(1) through (10) and such other clauses as the EPA may by appropriate instructions require, and also a clause requiring the subcontractors to include these clauses in any lower tier subcontracts. The prime contractor shall be responsible for the compliance by any subcontractor or lower tier subcontractor with all the contract clauses in 29 CFR 5.5.

7. Contract termination: debarment. A breach of the contract clauses in 29 CFR 5.5 may be grounds for termination of the contract, and for debarment as a contractor and a subcontractor as provided in 29 CFR 5.12.
8. Compliance with Davis-Bacon and Related Act requirements. All rulings and interpretations of the Davis-Bacon and Related Acts contained in 29 CFR parts 1, 3, and 5 are herein incorporated by reference in this contract.
9. Disputes concerning labor standards. Disputes arising out of the labor standards provisions of this contract shall not be subject to the general disputes clause of this contract. Such disputes shall be resolved in accordance with the procedures of the Department of Labor set forth in 29 CFR parts 5, 6, and 7. Disputes within the meaning of this clause include disputes between the contractor (or any of its subcontractors) and [name of CWIFP borrower], Corps, the U.S. Department of Labor, or the employees or their representatives.
10. Certification of eligibility.
 - I. By entering into this contract, the contractor certifies that neither it (nor he or she) nor any person or firm who has an interest in the

contractor's firm is a person or firm ineligible to be awarded Government contracts by virtue of section 3(a) of the Davis-Bacon Act or 29 CFR 5.12(a)(1).

- II. No part of this contract shall be subcontracted to any person or firm ineligible for award of a Government contract by virtue of section 3(a) of the Davis-Bacon Act or 29 CFR 5.12(a)(1).
 - III. The penalty for making false statements is prescribed in the U.S. Criminal Code, 18 U.S.C. 1001.
- b. Contract Work Hours and Safety Standards Act. The following clauses set forth in paragraphs (b)(1), (2), (3), and (4) of this section shall be inserted in full in any contract in an amount in excess of \$100,000 and subject to the overtime provisions of the Contract Work Hours and Safety Standards Act. These clauses shall be inserted in addition to the clauses required by § 5.5(a) or § 4.6 of part 4 of this title. As used in this paragraph, the terms laborers and mechanics include watchmen and guards.
 1. Overtime requirements. No contractor or subcontractor contracting for any part of the contract work which may require or involve the employment of laborers or mechanics shall require or permit any such laborer or mechanic in any workweek in which he or she is employed on such work to work in excess of forty hours in such workweek unless such laborer or mechanic receives compensation at a rate not less than one and one-half times the basic rate of pay for all hours worked in excess of forty hours in such workweek.



APPENDIX B: CWIFP SPECIFICATION PACKAGE AND BID CONTRACT LANGUAGE

2. Violation; liability for unpaid wages; liquidated damages. In the event of any violation of the clause set forth in paragraph (b)(1) of this section the contractor and any subcontractor responsible therefor shall be liable for the unpaid wages. In addition, such contractor and subcontractor shall be liable to the United States (in the case of work done under contract for the District of Columbia or a territory, to such District or to such territory), for liquidated damages. Such liquidated damages shall be computed with respect to each individual laborer or mechanic, including watchmen and guards, employed in violation of the clause set forth in paragraph (b)(1) of this section, in the sum of \$25 for each calendar day on which such individual was required or permitted to work in excess of the standard workweek of forty hours without payment of the overtime wages required by the clause set forth in paragraph (b)(1) of this section.
3. Withholding for unpaid wages and liquidated damages. The [name of CWIFP borrower] shall upon its own action or upon written request of an authorized representative of the Department of Labor, or the Corps, withhold or cause to be withheld, from any moneys payable on account of work performed by the contractor or subcontractor under any such contract or any other Federal contract with the same prime contractor, or any other federally-assisted contract subject to the Contract Work Hours and Safety Standards Act, which is held by the same prime contractor, such sums as may be determined to be necessary to satisfy any liabilities of such contractor or subcontractor for unpaid wages and liquidated damages as provided in the clause set forth in paragraph (b)(2) of this section.
4. Subcontracts. The contractor or subcontractor shall insert in any subcontracts the clauses set forth in paragraph (b)(1) through (4) of this section and also a clause requiring the subcontractors to include these clauses in any lower tier subcontracts. The prime contractor shall be responsible for compliance by any subcontractor or lower tier subcontractor with the clauses set forth in paragraphs (b)(1) through (4) of this section.
 - c. In addition to the clauses contained in paragraph (b), in any contract subject only to the Contract Work Hours and Safety Standards Act and not to any of the other statutes cited in § 5.1, the contractor or subcontractor shall maintain payrolls and basic payroll records during the course of the work and shall preserve them for a period of three years from the completion of the contract for all laborers and mechanics, including guards and watchmen, working on the contract. Such records shall contain the name and address of each such employee, social security number, correct classifications, hourly rates of wages paid, daily and weekly number of hours worked, deductions made, and actual wages paid. Further, the EPA shall cause or require the [name of CWIFP borrower] to insert in any such contract a clause providing that the records to be maintained under this paragraph shall be made available by the contractor or subcontractor for inspection, copying, or transcription by authorized representatives of the [name of CWIFP borrower], Corps and the Department of Labor, and the contractor or subcontractor will permit such representatives to interview employees during working hours on the job.





APPENDIX B: CWIFP SPECIFICATION PACKAGE AND BID CONTRACT LANGUAGE

BUILD AMERICA, BUY AMERICA ACT

Other language may be included on contracts for clarity on this federal requirement if an applicable waiver applies. For example, if CWIFP has determined that the project is covered under the pending program waiver, indicate in contract documents, “This Project is covered under the CWIFP Waiver (date TBD), which waives BABA requirements.”

Suggested Contract Language:

Build America, Buy America (Effective May 14, 2022)
The Contractor acknowledges to and for the benefit of (“Purchaser”) and the United States Army Corps of Engineers (“Corps”) that it understands the goods and services under this Agreement are being funded with federal monies made available by the Corps Water Infrastructure Financing Program that have statutory requirements commonly known as “Build America, Buy America;” that requires all of the iron and steel, manufactured products, and construction materials used in the project to be produced in the United States (“Build America, Buy America Requirements”) including iron and steel, manufactured products, and construction materials provided by the Contractor pursuant to this Agreement. The Contractor hereby represents and warrants to and for the benefit of the Purchaser and Funding Authority (a) the Contractor has reviewed and understands the Build America, Buy America Requirements, (b) all of the iron and steel, manufactured products, and construction materials used in the project will be and/or have been produced in the United States in a manner that complies with the Build America, Buy America Requirements, unless a waiver of the requirements is approved, and

(c) the Contractor will provide any further verified information, certification or assurance of compliance with

this paragraph, or information necessary to support a waiver of the Build America, Buy America Requirements, as may be requested by the Purchaser or the Funding Authority. Notwithstanding any other provision of this Agreement, any failure to comply with this paragraph by the Contractor shall permit the Purchaser or Funding Authority to recover as damages against the Contractor any loss, expense, or cost (including without limitation attorney’s fees) incurred by the Purchaser or Funding Authority resulting from any such failure (including without limitation any impairment or loss of funding, whether in whole or in part, from the Funding Authority or any damages owed to the Funding Authority by the Owner). If the Contractor has no direct contractual privity with the Funding Authority, as a lender or awardee to the Purchaser for the funding of its project, the Purchaser and the Contractor agree that the Funding Authority is a third-party beneficiary and neither this paragraph (nor any other provision of this Agreement necessary to give this paragraph force or effect) shall be amended or waived without the prior written consent of the Funding Authority.

PROHIBITION ON CERTAIN TELECOMMUNICATIONS AND VIDEO SURVEILLANCE SERVICES OR EQUIPMENT

Suggested Contract Language:

Prohibition on Certain Telecommunications and Video Surveillance Services or Equipment (Effective August 13, 2020). The John S. McCain National Defense Authorization Act for Fiscal Year 2019 (P.L. 115- 232), at Section 889, prohibits the Corps financial assistance recipients, including CWIFP borrowers, from expending loan funds to procure or obtain; extend or renew a contract to procure or obtain; or enter into a contract (or extend or renew a contract) to procure or obtain equipment, ser-





APPENDIX B: CWIFP SPECIFICATION PACKAGE AND BID CONTRACT LANGUAGE

vices, or systems that use covered telecommunications equipment or services as a substantial or essential component of any system, or as critical technology as part of any system. As described in the Act, “covered telecommunications equipment or services” means:

- d.** Telecommunications equipment produced by Huawei Technologies Company or ZTE Corporation (or any subsidiary or affiliate of such entities).
- e.** For the purpose of public safety, security of government facilities, physical security surveillance of critical infrastructure, and other national security purposes, video surveillance and telecommunications equipment produced by Hytera Communications Corporation, Hangzhou Hikvision Digital Technology Company, or Dahua Technology Company (or any subsidiary or affiliate of such entities).
- f.** Telecommunications or video surveillance services provided by such entities or using such equipment.
- g.** Telecommunications or video surveillance equipment or services produced or provided by an entity that the Secretary of Defense, in consultation with the Director of the National Intelligence or the Director of the Federal Bureau of Investigation, reasonably believes to be an entity owned or controlled by, or otherwise connected to, the government of a covered foreign country.

The Act does not prohibit:

- a.** Procuring with an entity to provide a service that connects to the facilities of a third-party, such as backhaul, roaming, or interconnection arrangements.
- b.** Telecommunications equipment that cannot route or redirect user data traffic or permit visibility into any user data or packets that such equipment transmits or otherwise handles.



APPENDIX D: SAMPLE AIS CERTIFICATION LETTER

The following information is provided as a sample letter of step certification for AIS compliance. Documentation must be provided on company letterhead.

Date

Company Name

Company Address

City, State Zip

Subject: American Iron and Steel Step Certification for Project (XXXXXXXXXX) I, (company representative), certify that the (melting, bending, coating, galvanizing, cutting, etc.) process for (manufacturing or fabricating) the following products and/or materials shipped or provided for the subject project is in full compliance with the American Iron and Steel requirement as mandated in the US Army Corps of Engineers' Corps Water Infrastructure Financing Program.

Item, Products and/or Materials:

1. Xxx
2. Xxx
3. Xxx

Such process took place at the following location: _____

If any of the above compliance statements change while providing material to this project, we will immediately notify the prime contractor and the engineer.

Signed by company representative