

ADDENDUM No. 1

ITB No. 4496

West Liberty Reconstruction

Bids Due: May 11, 2017 at 2:00 P.M. (local time)

The following changes, additions, and/or deletions shall be made to the Invitation to Bid for West Liberty Reconstruction, ITB No. 4496, on which proposals will be received on/or before May 11, 2017, at 2:00 P.M. (local time).

The information contained herein shall take precedence over the original documents and all previous addenda (if any), and is appended thereto. **This Addendum includes 119 pages.**

Bidder is to acknowledge receipt of this Addendum No. 1, including all attachments (if any) in its Bid by so indicating on page ITB-1 of the Invitation to Bid Form. Bids submitted without acknowledgment of receipt of this addendum will be considered nonconforming.

The following forms provided within the ITB Document must be included in submitted bids at bid opening.

- City of Ann Arbor Prevailing Wage Declaration of Compliance
- City of Ann Arbor Living Wage Ordinance Declaration of Compliance
- Vendor Conflict of Interest Disclosure Form
- City of Ann Arbor Non-Discrimination Ordinance Declaration of Compliance

Bids that fail to provide these completed forms listed above upon bid opening will be rejected as non-responsive and will not be considered for award.

I. CORRECTIONS/ADDITIONS/DELETIONS/CLARIFICATIONS

Changes to the Bid documents outlined below are referenced to a page or Section in which they appear conspicuously. The Bidder is to take note in its review of the documents and include these changes as they may affect work or details in other areas not specifically referenced here.

Item #1: Pre-Bid Meeting Minutes and Sign-In Sheets pages ADD1-6 - 10

Item #2: Bid Forms, pages BF-1 thru BF-7; replace these pages with attached pages ADD1-11 - 17

Item #3: Insert Special Provision for Vertical Exploratory Investigation ADD1-18 - 19

Item #4: Insert Special Provision for Soil Erosion Control Inlet Filter ADD1-20

Item #5: Insert Special Provision for Reconstruct Structure ADD1-21 - 23

- Item #6: Insert Special Provision for Additional Depth Structure Adjust ADD1-24
- Item #7: Insert Special Provision for HMA Application Estimate ADD1-25
- Item #8: Insert Special Provision for Acceptance of Hot Mix Asphalt Mixture on Local Agency Projects ADD1-26 - 32
- Item #9: Insert Detailed Specification for Bike Hoops ADD1-33
- Item #10: Insert Detailed Specification for Removing and Salvaging Signs ADD1-34
- Item #11: Insert Detailed Specification for Trees and Plantings ADD1-35 - 36
- Item #12: Insert Detailed Specification for Tree Grate ADD1-37 - 38
- Item #13 Insert Detailed Specification for Street Light Foundation ADD1-39
- Item #14 Insert Detailed Specification for Street Light Assembly ADD1-40 - 42
- Item #15 Insert MDOT's Supplemental Specification for Errata to the 2012 Standard Specifications ADD1-43 - 72
- Item #16 Insert Wage Rate Decisions for Highway Construction ADD1-73 - 99
- Item #17 Insert Wage Rate Decisions for Heavy Construction ADD1-100 – 105
- Item #18 Replace Detailed Specification for Storm Sewer ADD1-106 - 107
- Item #19 Replace Special Provision for Drainage Structures ADD1-108 - 110
- Item #20 Replace Detailed Specification for Storm Water Treatment Structure ADD1-111 - 112
- Item #21 Replace Detailed Specification for Concrete Sidewalks, Sidewalk Ramps, and Driveway Approaches ADD1-113 - 114
- Item #22 Replace Special Provision for Temporary Water Main Line Stop ADD1- 115 - 119

II. REQUEST FOR INFORMATION

1. What is the max value of General Conditions?
 - Response: \$150,000 which is now noted in the revised Bid Form
2. What is the max value of Project Supervision?
 - Response: \$40,000 which is now noted in the revised Bid Form
3. Please verify the unit of measure for Pay Item 2057002. I assume this should be SY, not STA.
 - Response: The pay item is Syd, which is now in the revised Bid Form
4. How did you arrive at the quantity for Pay Item 2057021? Based on our review of the bid documents it appears that the majority of the excavated material will be “granular” and considered non-hazardous contaminated material. The Special Provision applies to ALL

excavated material on the project, regardless of association with other pay items. Based on the project staging and the assumed quantities of excavation detailed in the Machine Grading pay item, it appears that this quantity is going to be far greater than the 450 CY listed on the bid form. Please clarify why this quantity is so small.

- Response: The quantity has been revised to include utility and machine grading construction.
- i. Is there any possibility of revising the unit measure for this pay item to be in “tons” in lieu of loose volumetric measure? All of the landfilled material will be scaled prior to disposal and we will be invoiced by weight. Switching to a weight based unit of measure will eliminate several variables and make the process much easier to keep track of.
- Response: The unit will be tracked and paid per the special provision.
5. Please clarify the description of Pay Item 8237001 “Polyethylene wrap, 12 inch Directional Drilled”. I believe there is some missing language.
- Response: The pay item has been revised in the Bid Form to reflect the specification.
6. Will railroad flaggers be required for work around the Ann Arbor Railroad line? If so, how will they be paid for?
- Response: Flagging will likely be required. Permits have been applied for, but have not been received at this time. This item will be handled via a change order if necessary.
7. Please identify how the water main should be connected / stubbed at the end of Stage 1 construction. The plans do not indicate any temporary interconnections at the end of the Stage.
- Response: A 12” GV&W will be installed at 5+75, and 2 – 90deg bends will be utilized to make the temporary connection. A plan sheet will be issued Monday, 5/8/17 detailing this.
8. Please clarify Pay Item 8037010 “Brick, Rem and Salvage”. Does this pay item include the reconstruction of the brick paving area quantity as detailed, or is this just a removal / salvage pay item? The Special Provision is not clear.
- Response: Yes, payment includes reconstruction.
9. Please clarify the intent of Pay Item 2047011 “Pavement, Rem”. Is the intent that this pay item will cover the removal of composite pavement, if encountered, without additional compensation for the underlying surface (concrete base courses, as encountered)?
- Response: Yes, payment will cover full-depth pavement removal without additional compensation for composite pavements.
10. Do the proposed storm sewers need to be televised after installation / prior to acceptance?
- Response: Yes as noted in revised specification.
11. The Special Provision for “Concrete Sidewalks, Sidewalk Ramps and Driveway Approaches” details the requirement for 8” of Granular Material Class II under all sidewalk and ramps in the downtown area. The plans call for 6” of sand under the sidewalks / ramps. Please clarify which is correct.
- Response: Please see the revised specification for clarification. 6” is required under sidewalk, and 8” will be required under the extended sidewalk in the bumpouts. 8” is required under the ramps.
12. The Special Provision for “Water Main And Appurtenances” calls for ALL restrained joint pipe to be TR Flex or equal. This would apply to the open cut areas as well as the railroad crossing (see page BF-79, 1st paragraph). Shouldn’t the open cut pipe be push joint with field lok gaskets? Fittings aren’t required to be TR Flex, why would the pipe need to be?

- Response: Restrained joints will be required in some areas of open cut, and should be TR Flex or equal.
13. The Special Provision for “Water Main And Appurtenances” calls for the use of NITRILE gaskets for push-on joints (see page BF-82, 4th paragraph). All other gaskets are normal. Should ALL of the gaskets / field loks be nitrile? Please clarify which should be used.
 - Response: Due to the presence of contaminants, all gaskets are to be nitrile.
 14. Please clarify if pavement replacement (as necessary) is incidental to the “Temporary Water Main Line Stop” pay item(s).
 - Response: The specification has been changed to include pavement replacement with the installation of the line stop.
 15. If dewatering is required to install the underground utilities, what environmental controls will be required?
 - Response: This will be addressed in another addendum.
 16. Where is the granular material Class II under the sidewalks, sidewalk ramps, and driveway approaches per the detailed specifications on BF-57 and shown on the typical sections paid?
 - Response: Payment is included in the item 3017021 Granular Material Class II Sand
 17. Per the detailed specifications on BF-57, the concrete is supposed to be high early. Per the detailed specification the extra concrete will be paid for separately. There is no pay item for the extra concrete.
 - Response: The specification has been revised to include the additional cement.
 18. How are the tree pit sections shown on plan sheets 8, 9, &10 paid? Is this the infiltration trench pay item? If so the quantity of 111 cyds. is way short.
 - Response: The tree pit is included in the payment for the tree as detailed in the attached specification for Trees and Plantings.
 19. Please provide a Special Provision or detail w/ application rate for the “Temporary Pavement” pay item.
 - Response: Application rate is included in the attached HMA Application Estimate
 20. Please clarify if the aggregate base replacement in the utility trenches will be incidental to the utility installation, or will it be paid for separately. (See trench details on sheet 11 of the plans.)
 - Response: No, it will be paid separately.
 21. Please clarify if CLII sand for utility backfill will need to meet City of Ann Arbor specifications or if MDOT CLII sand is acceptable. (See trench details on sheet 11 of the plans.)
 - Response: MDOT CI II sand is acceptable for trench backfill.
 22. Please clarify if the Pay Item 2050041 “Subgrade Undercutting, Type II” includes the aggregate refill. There is no special provision for this item. Typically, on City Projects, the refill material (sand / aggregate) is paid for separately.
 - Response: In accordance with section 205 of the 2012 Standard Specifications for Construction, backfill material is included in the undercut pay item.
 23. Will the Pay Item 4047001 “Infiltration Trench” include payment for volumes of excavated material / backfill as necessary to install OSHA approve excavations? For example, the detail as shown on sheet 8 of the plans is not realistic. Based on the soil borings and insitu soils there is no possibility of vertical trench walls for this application. This may also increase the sidewalk removal and replacement limits.

- Response: The trench wall will be revised to be allow for safe construction, while preserving adjacent sidewalk. The revised plan sheet will be issued Monday 5/8/17.
24. The Special Provision for Drainage Structures requires that all drainage structures should be designed to accommodate HL-93 Modified Live Load requirements. This is a bridge specification and is not standard for road projects. As such, this specification will increase the cost of drainage structures significantly and require project specific engineering to certify the structures. Please verify that you want to use this specification in lieu of the typical Orange Book standards (ASTM C478).
- Response: This note has been deleted from the attached specification. It was in reference to the Storm Water Control Structure and is noted in the revised specification.
25. Please review the Trench Detail 1A. Based on the specified pipe spacing there will not be enough room between the parallel runs to properly compact the bedding aggregate for pipe support. Please consider an increase in the pipe spacing.
- Response: The detail has an incorrect dimension of 5'; it should be 8'.
26. Can you please specify which tree grate insert (not frame) will be required for the project?
- Response: It has been noted in the attached specification.

Bidders are responsible for any conclusions that they may draw from the information contained in the Addendum.

West Liberty Reconstruction (ITB No. 4496)

Pre-Bid Meeting Minutes April 27, 2017, 10:30 a.m., 4th Floor Conference Room, City Hall

I. Introductions

II. General

a. Project Overview

West Liberty Street Reconstruction: the reconstruction of West Liberty from a point west of the railroad tracks west of First Street to Main Street. Includes the installation of a new 12" water main, a portion of which is bored under the rail road, storm water improvements including storage in oversized pipe and infiltration trenches, replacement of street lights, complete road reconstruction including edge drain, sand and aggregate base, curb and gutter, and full depth asphalt, and minor street scape improvements. Project to span two construction seasons.

Bid Opening – May 11, 2017, 2:00 p.m.

Sealed bids to be delivered to the Customer Service Desk (first floor City Hall) before this time.

b. Standard Specifications and Detailed Specifications

i. Construction Specifications (MDOT 2012 Standard Specifications for Construction)

ii. Project Schedule

- Starting Date – July 24, 2017
- Completion Date – June 30, 2018
- Project Phasing
 - Phase I – July 24, 2017 – October 27, 2017
 - Phase II – April 16, 2018 – June 30, 2018
- Hours of Work: 7:00 am – 8:00 pm Monday thru Saturday (Sundays w/approval)

iii. General Conditions

- Solid waste and recycling – Solid waste and recycling happens 6 days a week in the early mornings. Access across Liberty at both alleys must be restored to permit collection.
- Sweeping – Since work is occurring in the downtown area, frequent sweeping will be required, potentially multiple times a day if directed by the engineer.

iv. Project Supervision – required full time during the duration of the project.

v. NEW PAY ITEM – Certified Payroll Compliance and Reporting – the City will be enforcing compliance via review of payrolls to be submitted on a weekly basis for the Prime contractor and first tier subcontractors. This pay item will address the administrative costs incurred by the Contractor and any subcontractors to compile, review, and submit payrolls for City review.

vi. Brick Pavers – Wheeler Center has a stockpile and the approximate quantity available will be noted on the addendum.

West Liberty Reconstruction (ITB No. 4496)

- vii. Street Light Assembly
 - Lead time
 - City will supply luminaires

III. Construction

- a. Construction and Sequencing
- b. Maintenance of Traffic
- c. Special Concerns (local traffic access, pedestrian access, tree protection...) Temporary ramps will be used. Pedestrians will not be detoured around the construction site due to business in the construction area who are being heavily affected.

IV. Addendum Items

- a. Addendum 1 issued soon
 - i. Street light specification
 - ii. Tree Grate specification
 - iii. Bike hoop info
 - iv. Temporary Ramps
 - v. Wage Rate Decision (Highway and Heavy)

V. Other Items

- a. Railroad permit is in the process of being obtained. If any additional flagging is required, it will be stated in the addendum.

VI. Questions

- a. What is the engineers estimate for this project?
 - 1. The projected cost of this project from the engineers estimate is roughly 2.4 Million.

Contact Information:

Jennifer Nelson
Project Manager
Phone: (734) 794-6410 ext. 43672
E-mail: jnelson@a2gov.org

PREBID MEETING MEETING SIGN-IN SHEET

PROJECT: W Liberty Street Reconstruction

File No. 2015-034

Date: 4/27/17

PLEASE PRINT

NAME	REPRESENTING	MAILING ADDRESS	TELEPHONE	EMAIL
<i>JN</i> Jennifer Nelson Project Engineer	City of Ann Arbor - Project Management	Address: <u>301 East Huron St, P.O. Box 8647</u> City, State: <u>Ann Arbor, MI</u> Zip: <u>48107-8647</u>	Office: (734) <u>794-6410 x43672</u> Fax: (734) 994-1744	jnelson@a2gov.org
Dave Clemons CES Supervisor	City of Ann Arbor - Project Management	Address: <u>301 East Huron St, P.O. Box 8647</u> City, State: <u>Ann Arbor, MI</u> Zip: <u>48107-8647</u>	Office: (734) <u>794-6410 x43612</u> Fax: (734) 994-1744	dclemons@a2gov.org
<i>CC</i> Chris Carson Design Engineer	City of Ann Arbor - Project Management	Address: <u>301 East Huron St, P.O. Box 8647</u> City, State: <u>Ann Arbor, MI</u> Zip: <u>48107-8647</u>	Office: (734) <u>794-6410 x43631</u> Fax: (734) 996-3293	ccarson@a2gov.org
Andrea Ratliff Engineering Analyst <i>AMR</i>	City of Ann Arbor - Project Management	Address: <u>301 East Huron St, P.O. Box 8647</u> City, State: <u>Ann Arbor, MI</u> Zip: <u>48107-8647</u>	Office: (734) <u>794-6410 x43648</u> Fax: (734) 996-3293	aratliff@a2gov.org
Brendan Fons <i>Fons</i>	Fonson Company, Inc.	Address: <u>7644 Whitmore Lake Rd.</u> City, State: <u>Brighton, MI</u> Zip: <u>48116</u>	Office: (810) <u>-231-5188</u> Mobile: (810) <u>-397-3065</u>	bfons@fonsoninc.com
		Address: _____ City, State: _____ Zip: _____	Office: () _____ Mobile: () _____	
		Address: _____ City, State: _____ Zip: _____	Office: () _____ Mobile: () _____	
		Address: _____ City, State: _____ Zip: _____	Office: () _____ Mobile: () _____	

PREBID MEETING MEETING SIGN-IN SHEET

PROJECT: W Liberty Street Reconstruction

File No. 2015-034

Date: 4/27/17

MEETING SIGN-IN SHEET PLEASE PRINT

NAME	REPRESENTING	MAILING ADDRESS	TELEPHONE	EMAIL
DUSTON KIPKE	E.T. MACKENZIE COMPANY	Address: <u>6400 JACKSON RD</u> City, State: <u>ANN ARBOR, MI</u> Zip: <u>48103</u>	Office: (<u>734</u>) <u>761-5050</u> Mobile: () _____	<u>dkipke@mackenzie</u> <u>co.com</u>
DAVID WILKIE	DOUGLAS N. HIGGINS, INC.	Address: <u>3390 TRAVIS POINTE RO.</u> <u>STE A</u> City, State: <u>ANN ARBOR, MI</u> Zip: <u>48108</u>	Office: (<u>734</u>) <u>996-9500</u> Mobile: () _____	<u>dwilkie@</u> <u>dnhiggins.com</u>
JOHN NIEMIEC	E.T. MACKENZIE COMPANY	Address: <u>6400 JACKSON ROAD</u> City, State: <u>ANN ARBOR, MI</u> Zip: <u>48103</u>	Office: (<u>734</u>) <u>761.5050</u> Mobile: (<u>734</u>) <u>216.0995</u>	<u>jniemiec@</u> <u>mackenzereco.com</u>
		Address: _____ City, State: _____ Zip: _____	Office: () _____ Mobile: () _____	
		Address: _____ City, State: _____ Zip: _____	Office: () _____ Mobile: () _____	
		Address: _____ City, State: _____ Zip: _____	Office: () _____ Mobile: () _____	
		Address: _____ City, State: _____ Zip: _____	Office: () _____ Mobile: () _____	
		Address: _____ City, State: _____ Zip: _____	Office: () _____ Mobile: () _____	

PREBID MEETING MEETING SIGN-IN SHEET

PROJECT: W Liberty Street Reconstruction

File No. 2015-034

Date: 4/27/17

MEETING SIGN-IN SHEET

PLEASE PRINT

NAME	REPRESENTING	MAILING ADDRESS	TELEPHONE	EMAIL
Shelton Henige	J. Ranck Electric	Address: <u>1993 Gover Parkway</u> City, State: <u>Mount Pleasant, MI</u> Zip: <u>48858</u>	Office: (<u>989</u>) <u>775-7323</u> Mobile: () _____	<u>Nbatterbee@ranck.com</u>
Jacob Bailey	Bailey Excavating	Address: <u>1073 Toro Dr.</u> City, State: <u>Jackson, MI</u> Zip: <u>49201</u>	Office: (<u>517</u>) <u>750-3030</u> Mobile: (<u>517</u>) <u>740-0371</u>	<u>Jacob Bailey@Bailey-Excavating.com</u>
		Address: _____ City, State: _____ Zip: _____	Office: () _____ Mobile: () _____	
		Address: _____ City, State: _____ Zip: _____	Office: () _____ Mobile: () _____	
		Address: _____ City, State: _____ Zip: _____	Office: () _____ Mobile: () _____	
		Address: _____ City, State: _____ Zip: _____	Office: () _____ Mobile: () _____	
		Address: _____ City, State: _____ Zip: _____	Office: () _____ Mobile: () _____	
		Address: _____ City, State: _____ Zip: _____	Office: () _____ Mobile: () _____	

BID FORM
Section 1 - Schedule of Prices
Project: ITB 4496 - West Liberty Street Reconstruction

ITEM No.	DESCRIPTION	UNIT	ESTIMATED QUANTITY	UNIT PRICE	AMOUNT (\$)
1507051	Audiovisual Tape Coverage	LS	1	\$ _____	\$ _____
1507051	General Conditions, Max \$150,000	LS	1	\$ _____	\$ _____
1507051	Project Supervision, Max \$40,000	LS	1	\$ _____	\$ _____
1507051	Certified Payroll Compliance and Reporting	LS	1	\$ _____	\$ _____
2020004	Tree, Rem, 6 inch to 18 inch	Ea	9	\$ _____	\$ _____
2030011	Dr Structure, Rem	Ea	18	\$ _____	\$ _____
2037001	Sewer, Rem	Ft	355	\$ _____	\$ _____
2037001	Sewer, Abandon	Ft	46	\$ _____	\$ _____
2040020	Curb and Gutter, Rem	Ft	2477	\$ _____	\$ _____
2040055	Sidewalk, Rem	Syd	1438	\$ _____	\$ _____
2047011	Pavement, Rem	Syd	7806	\$ _____	\$ _____
2040080	Exploratory Investigation, Vertical	Ft	18	\$ _____	\$ _____
2050041	Subgrade Undercutting, Type II	Cyd	370	\$ _____	\$ _____
2057002	Machine Grading, Modified,	Sta	15.4	\$ _____	\$ _____
2057002	Sidewalk Grading	Syd	1515	\$ _____	\$ _____
2057021	Non-hazardous Contaminated Material Handling and Disposal (LM)	Cyd	7500	\$ _____	\$ _____
2087050	Erosion Control, Inlet Filter	Ea	24	\$ _____	\$ _____
3017021	Granular Material Class II Sand	Cyd	490	\$ _____	\$ _____
3017021	Subbase, CIP, Class II Granular Material	Cyd	1752	\$ _____	\$ _____
3020020	Aggregate Base, 8 inch	Syd	787	\$ _____	\$ _____
3027011	Aggregate Base, 8 inch, 21-AA, Modified	Syd	6307	\$ _____	\$ _____
4011120	Steel Casing Pipe, 12 inch, Jacked in Place	Ft	55	\$ _____	\$ _____
4021230	Sewer Bulkhead, 12 inch	Ea	5	\$ _____	\$ _____
4021260	Trench Undercut and Backfill (6A, Limestone)	Cyd	50	\$ _____	\$ _____

Total This Page \$ _____

BID FORM
Section 1 - Schedule of Prices
Project: ITB 4496 - West Liberty Street Reconstruction

ITEM No.	DESCRIPTION	UNIT	ESTIMATED QUANTITY	UNIT PRICE	AMOUNT (\$)
4027001	Sewer, CI C 76 IV, 12 inch, Tr Det I, Modified	Ft	544	\$ _____	\$ _____
4027001	Sewer, CI C 76 IV, 15 inch, Tr Det I, Modified	Ft	109	\$ _____	\$ _____
4027001	Sewer, CI C 76 IV, 18 inch, Tr Det I, Modified	Ft	52	\$ _____	\$ _____
4027001	Sewer, CI C 76 IV, 24 inch, Tr Det I, Modified	Ft	120	\$ _____	\$ _____
4027001	Sewer, CI C 76 IV, 48 inch, Tr Det I, Modified	Ft	205	\$ _____	\$ _____
4030005	Dr Structure Cover, Adj, Case 1	Ea	29	\$ _____	\$ _____
4030006	Dr Structure Cover, Adj, Case 2	Ea	2	\$ _____	\$ _____
4030010	Dr Structure Cover, Type B	Ea	30	\$ _____	\$ _____
4030050	Dr Structure Cover, Type K	Ea	22	\$ _____	\$ _____
4030390	Dr Structure, Temp Lowering	Ea	90	\$ _____	\$ _____
4037001	Additional Depth Structure Adjust	Ft	19	\$ _____	\$ _____
4037001	Dr Structure, 48 inch dia, Add Depth	Ft	3.86	\$ _____	\$ _____
4037001	Dr Structure, 72 inch dia, Add Depth	Ft	5.86	\$ _____	\$ _____
4037050	Dr Structure Cover, Water-tite	Ea	8	\$ _____	\$ _____
4037050	Dr Structure, Cleanout, 8 inch dia	Ea	8	\$ _____	\$ _____
4037050	Dr Structure, 48 inch dia	Ea	3	\$ _____	\$ _____
4037050	Dr Structure, 48 inch dia, Inlet Leaching	Ea	8	\$ _____	\$ _____
4037050	Dr Structure, Type III, 48 inch dia	Ea	2	\$ _____	\$ _____
4037050	Dr Structure, 72 inch dia	Ea	7	\$ _____	\$ _____
4037050	Dr Structure, 84 inch dia	Ea	2	\$ _____	\$ _____
4037050	Dr Structure, 24 inch dia	Ea	8	\$ _____	\$ _____
4037050	Dr Structure, 36 inch dia	Ea	5	\$ _____	\$ _____
4037050	Reconstruct Structure	Ea	3	\$ _____	\$ _____
4037050	Storm Water Control Structure 84 inch dia	Ea	1	\$ _____	\$ _____

Total This Page \$ _____

BID FORM
Section 1 - Schedule of Prices
Project: ITB 4496 - West Liberty Street Reconstruction

ITEM No.	DESCRIPTION	UNIT	ESTIMATED QUANTITY	UNIT PRICE	AMOUNT (\$)
4040063	Underdrain, Subbase, 6 inch	Ft	1393	\$ _____	\$ _____
4040075	Underdrain, Subgrade, 8 inch	Ft	250	\$ _____	\$ _____
4047001	Infiltration Trench	Cyd	111	\$ _____	\$ _____
5010045	HMA, 3E3	Ton	1085	\$ _____	\$ _____
5010051	HMA, 4E3	Ton	724	\$ _____	\$ _____
5010057	HMA, 5E3	Ton	545	\$ _____	\$ _____
5010703	HMA, LVSP Hand Patching	Ton	75	\$ _____	\$ _____
5017011	Temporary Pavement	Syd	111	\$ _____	\$ _____
8027001	Curb and Gutter, Concrete	Ft	2270	\$ _____	\$ _____
8027001	Driveway Opening, Conc, Detail M	Ft	414	\$ _____	\$ _____
8027001	Integral Sidewalk Retaining Wall, 6 inch to 18 inch	Ft	120	\$ _____	\$ _____
8037001	Detectable Warning Surface	Ft	130	\$ _____	\$ _____
8037010	Brick, Rem and Salvage	Sft	2821	\$ _____	\$ _____
8037010	Sidewalk, Concrete, 6 inch, Modified	Sft	7751	\$ _____	\$ _____
8037010	Sidewalk Ramp, Approach, Concrete, 8 inch, Modified	Sft	5441	\$ _____	\$ _____
8037010	Brick Pavers, New	Sft	3414	\$ _____	\$ _____
8037050	Bike Hoops, Rem	Ea	6	\$ _____	\$ _____
8037050	Bike Hoops, Surface Mount	Ea	8	\$ _____	\$ _____
8080007	Fence, Protective	Ft	2500	\$ _____	\$ _____
8107050	Remove and Replace Parking Meter Posts	Ea	12	\$ _____	\$ _____
8107050	Sign, Rem and Salvage	Ea	3	\$ _____	\$ _____
8110049	Pavt Mrkg, Ovly Cold Plastic, Bike Arrow Sym	Ea	4	\$ _____	\$ _____
8110058	Pavt Mrkg, Ovly Cold Plastic, Bike, Small Sym	Ea	4	\$ _____	\$ _____
8110063	Pavt Mrkg, Ovly Cold Plastic, Lt Turn Arrow Sym	Ea	1	\$ _____	\$ _____

Total This Page \$ _____

BID FORM
Section 1 - Schedule of Prices
Project: ITB 4496 - West Liberty Street Reconstruction

ITEM No.	DESCRIPTION	UNIT	ESTIMATED QUANTITY	UNIT PRICE	AMOUNT (\$)
8110068	Pavt Mrkg, Ovly Cold Plastic, Only	Ea	1	\$ _____	\$ _____
8110078	Pavt Mrkg, Ovly Cold Plastic, Thru Arrow Sym	Ea	1	\$ _____	\$ _____
8110079	Pavt Mrkg, Ovly Cold Plastic, Sharrow	Ea	4	\$ _____	\$ _____
8110092	Pavt Mrkg, Polyurea, 4 inch, Yellow	Ft	1738	\$ _____	\$ _____
8110094	Pavt Mrkg, Polyurea, 6 inch, White	Ft	245	\$ _____	\$ _____
8110110	Pavt Mrkg, Polyurea, 12 inch, Crosswalk	Ft	1119	\$ _____	\$ _____
8110114	Pavt Mrkg, Polyurea, 24 inch, Stop Bar	Ft	283	\$ _____	\$ _____
8110411	Pavt Mrkg Polyurea Railroad Symbol	Ea	4	\$ _____	\$ _____
8120012	Barricade, Type III, High Intensity, Double Sided, Lighted, Furn	Ea	25	\$ _____	\$ _____
8120013	Barricade, Type III, High Intensity, Double Sided, Lighted, Oper	Ea	25	\$ _____	\$ _____
8120030	Channelizing Device, 42 inch, Furn	Ea	20	\$ _____	\$ _____
8120031	Channelizing Device, 42 inch, Oper	Ea	20	\$ _____	\$ _____
8120130	Lighted Arrow, Type B, Furn	Ea	1	\$ _____	\$ _____
8120131	Lighted Arrow, Type B, Oper	Ea	1	\$ _____	\$ _____
8120170	Minor Traffic Control, Modified, Max \$6,000	LS	1	\$ _____	\$ _____
8120210	Pavt Mrkg, Longit, 6 inch or Less Width, Rem	Ft	150	\$ _____	\$ _____
8120220	Pavt Mrkg, Wet Reflective, Type NR, Paint, 4 inch, White, Temp	Ft	2569	\$ _____	\$ _____
8120250	Plastic Drum, High Intensity, Furn	Ea	200	\$ _____	\$ _____
8120251	Plastic Drum, High Intensity, Oper	Ea	200	\$ _____	\$ _____
8120310	Sign Cover	Ea	5	\$ _____	\$ _____
8120330	Sign, Portable, Changeable Message, Furn	Ea	2	\$ _____	\$ _____
8120331	Sign, Portable, Changeable Message, Oper	Ea	2	\$ _____	\$ _____
8120350	Sign, Type B, Temp, Prismatic, Furn	Sft	981	\$ _____	\$ _____
8120351	Sign, Type B, Temp, Prismatic, Oper	Sft	981	\$ _____	\$ _____

Total This Page \$ _____

BID FORM
Section 1 - Schedule of Prices
Project: ITB 4496 - West Liberty Street Reconstruction

ITEM No.	DESCRIPTION	UNIT	ESTIMATED QUANTITY	UNIT PRICE	AMOUNT (\$)
8120370	Traf Regulator Control	LS	1	\$ _____	\$ _____
8127001	Pavt Mrkg, Type NR, 24 inch, White, Temp	Ft	60	\$ _____	\$ _____
8127050	Pedestrian Type II Barricade, Temp	Ea	4	\$ _____	\$ _____
8127050	Temporary Curb Ramp Perpedicular to Curb	Ea	2	\$ _____	\$ _____
8127050	Temporary Curb Ramp Parallel to Curb	Ea	2	\$ _____	\$ _____
8157050	Nyssa Sylvatica (Blackgum) 2.5" B-B	Ea	13	\$ _____	\$ _____
8157050	Ulmus Americana New Marmony (American Elm)	Ea	13	\$ _____	\$ _____
8157050	Tree Grates	Ea	42	\$ _____	\$ _____
8167011	Slope Restoration	Syd	210	\$ _____	\$ _____
8190505	Wood Pole, Rem	Ea	1	\$ _____	\$ _____
8197001	Conduit, DB, 2, Schedule 80 PVC, 3 inch	Ft	3125	\$ _____	\$ _____
8197001	Electrical Cable, DB, 600V, 3C, 1-#6, 2-#4	Ft	6250	\$ _____	\$ _____
8197010	Street Light, Rem	Ea	28	\$ _____	\$ _____
8197010	Remove Street Light Foundation	Ea	28	\$ _____	\$ _____
8197050	Communication Handhole Assembly, Complete	Ea	20	\$ _____	\$ _____
8197050	Electrical Handhole Assembly, Complete	Ea	14	\$ _____	\$ _____
8197050	Street Light Foundations LTFX-1	Ea	18	\$ _____	\$ _____
8197050	Street Light Foundations LTFX-2	Ea	10	\$ _____	\$ _____
8197050	Street Light Assembly, Complete LTFX-1	Ea	18	\$ _____	\$ _____
8197050	Street Light Assembly, Complete LTFX-2	Ea	10	\$ _____	\$ _____
8197050	Street Light Disconnect Box, Complete	Ea	1	\$ _____	\$ _____
8207050	Remove Mast Arm Foundation	Ea	5	\$ _____	\$ _____
8207050	Remove Ped Foundation	Ea	4	\$ _____	\$ _____
8207050	Mast Arm Foundation	Ea	5	\$ _____	\$ _____

Total This Page \$ _____

BID FORM
Section 1 - Schedule of Prices
Project: ITB 4496 - West Liberty Street Reconstruction

ITEM No.	DESCRIPTION	UNIT	ESTIMATED QUANTITY	UNIT PRICE	AMOUNT (\$)
8237001	4 inch thru 8 inch Water Main, Abandon	Ft	625	\$ _____	\$ _____
8237001	10 inch and 12 inch Water Main, Abandon	Ft	175	\$ _____	\$ _____
8237001	D.I. Water Main, w/ Polyethylene Wrap, 4 inch, Tr Det I, Mod	Ft	100	\$ _____	\$ _____
8237001	D.I. Water Main, w/ Polyethylene Wrap, 6 inch, Tr Det I, Mod	Ft	40	\$ _____	\$ _____
8237001	D.I. Water Main, w/ Polyethylene Wrap, 8 inch, Tr Det I, Mod	Ft	20	\$ _____	\$ _____
8237001	D.I. Water Main, w/ Polyethylene Wrap, 10 inch, Tr Det I, Mod	Ft	20	\$ _____	\$ _____
8237001	D.I. Water Main, w/ Polyethylene Wrap, 12 inch, Tr Det I, Mod	Ft	916	\$ _____	\$ _____
8237001	D.I. W.M. TR-Flex w/ Double Polyethylene Wrap, 12 inch Directional Drilled	Ft	302	\$ _____	\$ _____
8237001	Excavate and Backfill Water Service Trench Tap and Lead	Ft	341	\$ _____	\$ _____
8237050	Gate Valve-in-Box, Rem	Ea	4	\$ _____	\$ _____
8237050	Gate Valve-in-Well, Rem	Ea	2	\$ _____	\$ _____
8237050	Fire Hydrant, Rem	Ea	3	\$ _____	\$ _____
8237050	90 deg Bend, 4 inch	Ea	1	\$ _____	\$ _____
8237050	45 deg Bend, 6 inch	Ea	1	\$ _____	\$ _____
8237050	90 deg Bend, 6 inch	Ea	1	\$ _____	\$ _____
8237050	11.25 deg Bend, 12 inch	Ea	6	\$ _____	\$ _____
8237050	22.5 deg Bend, 12 inch	Ea	1	\$ _____	\$ _____
8237050	45 deg Bend, 12 inch	Ea	6	\$ _____	\$ _____
8237050	Tee, 6 inch x 6 inch x 6 inch	Ea	1	\$ _____	\$ _____
8237050	Tee, 10 inch x 10 inch x 10 inch	Ea	1	\$ _____	\$ _____
8237050	Tee, 12 inch x 12 inch x 4 inch	Ea	1	\$ _____	\$ _____
8237050	Tee, 12 inch x 12 inch x 8 inch	Ea	3	\$ _____	\$ _____
8237050	Tee, 12 inch x 12 inch x 12 inch	Ea	6	\$ _____	\$ _____
8237050	Fire Hydrant Assembly, with Extensions, Complete	Ea	3	\$ _____	\$ _____

Total This Page \$ _____

BID FORM
 Section 1 - Schedule of Prices
 Project: ITB 4496 - West Liberty Street Reconstruction

ITEM No.	DESCRIPTION	UNIT	ESTIMATED QUANTITY	UNIT PRICE	AMOUNT (\$)
8237050	Gate Valve-in-Box, 4 inch	Ea	4	\$ _____	\$ _____
8237050	Gate Valve-in-Box, 12 inch	Ea	1	\$ _____	\$ _____
8237050	Gate Valve-in-Well, 12 inch	Ea	8	\$ _____	\$ _____
8237050	Water Main Line Stop 6 inch and 8 inch	Ea	6	\$ _____	\$ _____
8237050	Water Main Line Stop 10 inch and 12 inch	Ea	3	\$ _____	\$ _____
8237050	Reducer, 8 inch x 6 inch	Ea	2	\$ _____	\$ _____
8237050	Reducer, 10 inch x 12 inch	Ea	1	\$ _____	\$ _____
8237050	Reducer, 12 inch x 6 inch	Ea	2	\$ _____	\$ _____
8237050	Reducer, 12 inch x 4 inch	Ea	4	\$ _____	\$ _____
8507001	Sewer, SDR 35 PVC, Service Lead, 4 inch or 6 inch, Tr Det I Mod	Ft	50	\$ _____	\$ _____

Total This Page \$ _____

Total From BF-1 \$ _____

Total From BF-2 \$ _____

Total From BF-3 \$ _____

Total From BF-4 \$ _____

Total From BF-5 \$ _____

Total From BF-6 \$ _____

Contractor: _____

Total Base Bid \$ _____

MICHIGAN
DEPARTMENT OF TRANSPORTATION

SPECIAL PROVISION
FOR
VERTICAL EXPLORATORY INVESTIGATION

OPR:DJA

1 of 2

APPR:JAR:DBP:01-12-12
FHWA:APPR:01-12-12

a. Description. This work consists of conducting a vertical exploratory investigation to expose an existing culvert, sewer or utility in order to verify the location, condition, size, material and alignment; allowing the Engineer to document the necessary information; and backfilling the excavation. This work includes providing necessary lane, shoulder and/or sidewalk closures required to perform work.

b. Materials. Use Granular Material Class III in conformance with section 902 of the Standard Specifications for Construction for backfill. Use material removed during exploratory investigation for backfill only if approved by of the Engineer.

c. Construction. The owner of any sewer or utility to be exposed will not take the facilities out of service during the exploratory investigation. Contact utility owners in accordance with subsection 107.12 of the Standard Specifications for Construction.

Establish necessary lane, shoulder and/or sidewalk closures required to perform work.

Advance the exploratory excavation using vacuum boring excavation, hand digging, conventional machine excavation, or a combination thereof subject to approval of the Engineer. Allow the Engineer access to document the necessary information. If the technique used to advance the excavation is causing damage to the existing facilities, cease all work until an alternate method is approved by the Engineer.

Take care to protect the exposed culvert, sewer or utility from damage during construction. Repair or replace culvert, sewer or utility, damaged during exploratory excavation, in accordance with the standard specifications and as approved by the Engineer.

Obtain the Engineer's approval before backfilling the excavation. Complete backfilling no later than 24 hours after approval has been given. Backfill in accordance with subsection 204.03.C of the Standard Specifications for Construction. Dispose of excess material according to the standard specifications.

The Contractor is responsible for all costs associated with the repair work and out of service time of all broken or damaged existing culverts, sewers or utilities as a result of any action by the Contractor. If the exploratory investigation results in damage to private utilities, contact the owner of such utility to coordinate the repair.

d. Measurement and Payment. The completed work, as described, will be measured and paid for at the contract unit price using the following pay item:

Pay Item**Pay Unit**

Exploratory Investigation, VerticalFoot

Exploratory Investigation, Vertical will be measured by the foot from top of existing grade vertically to the bottom of the excavation for a 4-foot maximum diameter hole, or as approved by the Engineer. The excavated depth of each 4-foot maximum diameter hole will be measured separately for payment.

Exploratory Investigation, Vertical includes all labor, equipment and materials required to complete the work, including all costs associated with repair or replacement resulting from the contractor's activities.

CITY OF ANN ARBOR
SPECIAL PROVISION
FOR
SOIL EROSION CONTROL INLET FILTER

AA:JN

1 of 1

4/24/17

a. Description.- This work consists of installing and maintaining inlet filters in accordance with Section 208 of the 2012 Michigan Department of Transportation Standard Specifications for Construction and as shown on the plans. Filters shall be installed in existing and proposed inlets in order to minimize the erosion of soil and the sedimentation of water courses. The related work includes the installation, maintenance and removal of the filter cloth, cleaning as required during the performance of the project work, removing and disposing of accumulated sediment, and replacement of filters if required by the Engineer to provide a properly working inlet filter and a well-drained site.

b. Materials.- The inlet filters shall be in accordance with the REGULAR FLOW SILTSACK® manufactured by ACF Environmental (800) 448-3636; FLEXSTORM® Style FX manufactured by Advanced Drainage Systems, Inc. (800) 821-6710; CATCH-ALL® manufactured by Price & Company (866) 960-4300, or Engineer approved equal.

The Contractor shall submit product data sheets and a sample of the filter material for inlet filters for Engineer approval prior to ordering materials.

c. Methods of Construction.- The Contractor shall install, maintain, clean, and re-install and/or replace inlet filters in accordance with the manufacturer's specifications and as directed by the Engineer. The Contractor shall dispose of debris off-site.

d. Measurement and Payment.- The completed work of Soil Erosion Control Inlet Filter will be paid for at the contract unit price for the following contract items (pay items):

<u>Contract Item (Pay Item)</u>	<u>Pay Unit</u>
Erosion Control, Inlet Filter	Each

"Erosion Control, Inlet Filter" will be measured by the unit installed and will be paid for at the contract unit price per each, for which price shall be payment in full for all labor, equipment, and materials needed to furnish, install, maintain, clean and remove the inlet filter, and re-install and/or replace the inlet filter as needed.

CITY OF ANN ARBOR
SPECIAL PROVISION
FOR
RECONSTRUCT STRUCTURE

AA:JN

1 of 3

4/24/17

a. Description.- This work shall consist of reconstructing drainage structures in accordance with Section 403 of the Michigan Department of Transportation 2012 Standard Specifications for Construction, as shown on the plans, and as specified herein. This work shall also apply to water main gate valve wells.

b. Materials.- The materials used for this work shall conform to Subsection 403.02 of the Michigan Department of Transportation 2012 Standard Specifications for Construction except as specified herein.

Storm sewer drainage structures shall be constructed of precast or cast in place reinforced concrete sections, or concrete masonry units. All sanitary sewer manholes and gate wells (water main valve manholes) shall be constructed of precast reinforced concrete sections.

Precast reinforced concrete bases, bottom sections, manhole risers, grade adjustment rings, concentric cones, eccentric cones, and flat slab tops shall conform to the requirements of ASTM C 478. Joints on precast manholes used on all sanitary sewers shall meet ASTM C 443, rubber O-ring gasket.

Concrete masonry units shall conform to the requirements for concrete masonry units for catch basins and manholes, ASTM C 139.

Concrete brick shall conform to the requirements for concrete building brick, ASTM C 55, Grade N-1.

Plastic coated manhole steps shall be injection molded of copolymer, polypropylene, encapsulating a 1/2 inch grade 60 steel reinforcing bar. Plastic-coated manhole steps shall meet the performance test described in ASTM C-478, Paragraph II, and shall have an impact resistance of 300 ft.-lbs., with only minor deflection and no cracking or breaking. The steps shall resist pull out forces of 1500 lbs.

c. Methods of Construction.- The construction methods used for reconstructing drainage structures, where directed by the Engineer, shall conform to Section 403.03 of the Michigan Department of Transportation 2012 Standard Specifications for Construction except as specified herein.

Excavation shall be carried to the depth and width required to permit the construction of the required base. The excavation width shall be greater than the base. The bottom of the excavation shall be trimmed to a uniform horizontal bed and be completely dewatered before any concrete is placed therein. Precast manhole bases and precast bottom sections are allowed.

Concrete block construction shall only be allowed for storm sewer manholes and inlets and shall be built of the size and dimensions shown on the Plans. The block shall be clean, laid in a

CITY OF ANN ARBOR
SPECIAL PROVISION
FOR
RECONSTRUCT STRUCTURE

AA:JN

2 of 3

4/24/17

full bed of mortar, and thoroughly bonded by completely filling the vertical end grooves with mortar so as to interlock with the adjacent block. The mortar beds and joints shall not exceed 3/4 inch thickness. The vertical joints are to be completely filled with the joints on the inside face rubbed full of mortar and struck smooth as the manhole, inlet or structure is built up. The entire outside face of the structure shall receive a 1/2" thick mortar coat and struck smooth. All masonry materials, sand, and water shall be heated to over 50° F during freezing weather, and the completed work shall be covered and protected from damage by freezing.

Circular precast manhole sections shall be constructed in accordance with the details as shown on the plans. Manhole stack units shall be constructed on level poured-in-place bases, precast concrete bases, or precast concrete bottom sections.

Precast cone sections shall be constructed in accordance with the details as shown on the plans. These units shall be eccentric for all manholes, precast or block. All structures shall be topped with a minimum of one, and a maximum of three, 2" tall, brick or precast adjustment courses.

Manholes, inlets, gate wells and structures shall be constructed within 2-1/2 inches of plumb.

Frames and cover castings shall be set in full mortar beds and pointed on the structure interior to a smooth, brushed finish. The covers shall be set flush with sidewalk, roadway pavement, or ground surfaces. The Engineer shall be notified prior to the final paving so as to allow inspection of the final casting adjustments for all utility structures. In gravel streets, covers shall be set six to eight inches below finished gravel surface.

Sewer pipes shall extend into structures a minimum of 1/2 inch and a maximum of 3 inches.

Flow channels for sewer structures shall be finished in accordance with the details as shown on the plans. All flow channels shall be screeded and floated to a smooth, uniform surface and troweled to a hard surface finish.

Stubs for future sewer connections shall be furnished and placed by the Contractor as shown on the Plans and as directed by the Engineer. Connections shall be properly supported and braced when not resting on original ground so that any settlement will not disturb the connection. Stubs shall consist of one length of sewer pipe, of the size indicated on the Plans, with a watertight plug.

The excavation shall be kept in a dry condition. All necessary dewatering shall be paid for separately in accordance with the Special Provision entitled "Dewatering".

All necessary adjustments required to accommodate encountered field conditions for reconstructed structures shall be included in the cost of the structure and will not be paid for separately.

CITY OF ANN ARBOR
SPECIAL PROVISION
FOR
RECONSTRUCT STRUCTURE

AA:JN

3 of 3

4/24/17

Sealing Manhole Cone/Chimney Interface Area:

Place an epoxy or urethane sealing product at the junction of the drainage structure cone/chimney interface as detailed on the plans or as directed by the Engineer. All products used shall be approved by the Engineer and shall be manufactured by one of the suppliers listed below:

NPR-3501 Neopoxy (epoxy) , manufactured by NeoPoxy International, 27057 Industrial Boulevard, Hayward, CA 94545, Ph: 510.782.1290, Fax: 510.782.1292 (www.NeoPoxy.us)

EasySeal SG (urethane) manufactured by Cretex Specialty Products, N16 W23390 Stone Ridge Drive, Suite A, Waukesha WI 53188, Ph 800 345 3764, Fax 262 542 0301 (www.cretexseals.com)

Flex-Seal (urethane), manufactured by Sealing Systems, Inc., 9350 County Road 19, Loretto, MN 55357, Ph 800-478-2054, Fax 763-478-8868 (www.ssisealingsystems.com)

For the purposes of this work, the manhole chimney is defined as the masonry units sitting atop the pre-cast concrete or manhole block corbel or cone sections and extending up to the bottom of the drainage structure cover. Apply sealant to the entire drainage structure chimney section. Thoroughly clean the chimney section as detailed in the sealant manufacturer's installation instruction. All products shall be applied in strict accordance with the manufacturer's recommendations and installation requirements. Approval of the chosen sealing product shall be obtained from the Engineer prior to commencement of the work.

d. Measurement and Payment.- The completed work as measured shall be paid at the contract unit price for the following contract items (pay items):

<u>(Contract Item) Pay Item</u>	<u>Pay Unit</u>
Reconstruct Structure	Each

Payment for this item of work shall include all labor, materials and equipment needed to accomplish the work, regardless of depth or type of structure.

CITY OF ANN ARBOR
SPECIAL PROVISION
FOR
ADDITIONAL DEPTH STRUCTURE ADJUST

AA:JN

1 of 1

4/24/17

a. Description.- This work shall consist of removing and disposing of portions of existing brick or block masonry drainage structures, and rebuilding drainage structures of concrete block masonry in conformance with Section 403 of the Michigan Department of Transportation 2012 Standard Specifications for Construction except as specified herein. Water main gate wells and gate box covers shall be considered to be included in this item of work.

This shall also cover the repair of manholes and structures where less than the substantial rebuilding of the structure, as determined by the Engineer, is required.

b. Materials.- The materials shall meet the requirements as specified in Section 403.02 of the Michigan Department of Transportation 2012 Standard Specifications except as specified herein.

Concrete masonry units shall conform to the requirements for concrete masonry units for catch basins and manholes, ASTM C 139.

Concrete brick shall conform to the requirements for concrete building brick, ASTM C 55, Grade N-1.

c. Construction Methods.- The Construction Methods shall meet the requirements of Section 403.03, except that the provisions of Section 403.03.D shall not apply to the work covered by this special provision.

The Contractor shall furnish and install pre-cast manhole tops (flat-tops) for the structures where needed. The flat-tops shall be included in this item of work and will not be paid for separately.

d. Measurement and Payment.- The completed work as measured for "Structure, Additional Depth Adjust" shall be paid for at the contract unit price for the following contract item (pay item):

<u>Contract Item (Pay Item)</u>	<u>Pay Unit</u>
Additional Depth Structure Adjust	Foot

"Additional Depth Structure Adjust" will be measured by depth in feet from a point 15 inches below finish grade of the structure down to the grade of the remaining structure, and will be paid for at the contract unit price per foot, which price shall be payment in full for all labor, equipment and materials needed to accomplish this work.

SPECIAL PROVISION
FOR
HMA APPLICATION ESTIMATE

AA: JAN

1 of 1

4/30/17

a. Description. This work shall consist of furnishing and placing (HMA) hot mix asphalt on the prepared aggregate or milled surfaces in accordance with the details shown on the plans and as specified in Section 501 of the Michigan Department of Transportation Standard Specifications for Construction, 2012 Edition with the exceptions and additions specified herein.

b. Materials.

Mainline Paving:

The HMA, 5E3 used for top course shall be 1.5 inches thick and have a yield of 170 pounds per square yard with a PG 64-28 binder. The HMA, 5E3 used for top course shall have an AWI = 260 minimum. The use of RAS is prohibited.

The HMA, 4E3 used for leveling course shall be 2 inches thick and have a yield of 226 pounds per square yard with a PG 64-28 binder.

The HMA, 3E3 used for base course shall be 3 inches thick and have a yield of 339 pounds per square yard with a PG 58-22 binder.

Temporary Pavement:

The HMA, 3E3 used for temporary pavement shall be 5 inches thick and placed in two lifts of 2.5 inches and shall have a yield of 275 pounds per square yard with a PG 58-22 binder.

HMA Hand Patching:

The LVSP used for hand patching shall have a variable yield, with an average of 220 pounds per square yard with a PG 58-28 binder.

c. Construction. Construction shall be in accordance with Section 501 of the 2012 MDOT Standard Specifications for Construction, and the Detailed Specifications for HMA Paving and HMA Acceptance contained within the contract documents.

A bond coat shall be applied before each lift of HMA mixture is placed. The rate of application shall be 0.10 gallons per square yard.

d. Measurement and Payment. Measurement shall be based on load weight tickets from a certified scale and accepted at the job site by a City of Ann Arbor agent.

Payment for HMA 5E3, 4E3, 3E3, and HMA LVSP Hand Patching shall include all labor, equipment and materials to complete this work.

Payment for Temporary Pavement shall include all labor, equipment and materials to complete this work, in addition to removing the pavement.

MICHIGAN
DEPARTMENT OF TRANSPORTATION

SPECIAL PROVISION
FOR
ACCEPTANCE OF HOT MIX ASPHALT MIXTURE ON LOCAL AGENCY PROJECTS

CFS:KPK

1 of 7

APPR:CJB:JWB:07-05-16
FHWA:APPR:07-05-16

a. Description. This special provision provides sampling and testing requirements for local agency projects using the roller method and the nuclear density gauge testing. Provide the hot mix asphalt (HMA) mixture in accordance with the requirements of the standard specifications, except where modified herein.

b. Materials. Provide aggregates, mineral filler (if required), and asphalt binder to produce a mixture proportioned within the master gradation limits shown in the contract, and meeting the uniformity tolerance limits in Table 1.

Table 1: Uniformity Tolerance Limits for HMA Mixtures

Parameter		Top and Leveling Course		Base Course		
Number	Description	Range 1 (a)	Range 2	Range 1 (a)	Range 2	
1	% Binder Content	-0.30 to +0.40	±0.50	-0.30 to +0.40	±0.50	
2	% Passing	# 8 and Larger Sieves	±5.0	±8.0	±7.0	±9.0
		# 30 Sieve	±4.0	±6.0	±6.0	±9.0
		# 200 Sieve	±1.0	±2.0	±2.0	±3.0
3	Crushed Particle Content (b)	Below 10%	Below 15%	Below 10%	Below 15%	
a. This range allows for normal mixture and testing variations. The mixture must be proportioned to test as closely as possible to the Job-Mix-Formula (JMF). b. Deviation from JMF.						

Parameter number 2 as shown in Table 1 is aggregate gradation. Each sieve will be evaluated on one of the three gradation tolerance categories. If more than one sieve is exceeding Range 1 or Range 2 tolerances, only the one with the largest exceedance will be counted as the gradation parameter.

The master gradation should be maintained throughout production; however, price adjustments will be based on Table 1. Aggregates which are to be used in plant-mixed HMA mixtures must not contain topsoil, clay, or loam.

c. Construction. Submit a Mix Design and a JMF to the Engineer. Do not begin production and placement of the HMA until receipt of the Engineer's approval of the JMF. Maintain the binder content, aggregate gradation, and the crushed particle content of the HMA mixture within the Range 1 uniformity tolerance limits in Table 1. For mixtures meeting the definition of top or leveling course, field regress air void content to 3.5 percent with liquid asphalt cement unless

specified otherwise on HMA application estimate. For mixtures meeting the definition of base course, field regress air void content to 3.0 percent with liquid asphalt cement unless specified otherwise on HMA application estimate.

Ensure all persons performing Quality Control (QC) and Quality Assurance (QA) HMA field sampling are "Local Agency HMA Sampling Qualified" samplers. At the Pre-Production or Pre-Construction meeting, the Engineer will determine the method of sampling to be used. Ensure all sampling is done in accordance with *MTM 313 (Sampling HMA Paving Mixtures)* or *MTM 324 (Sampling HMA Paving Mixtures Behind the Paver)*. Samples are to be taken from separate hauling loads.

For production/mainline type paving, obtain a minimum of two samples, each being 20,000 grams, each day of production, for each mix type. The Engineer will sample and maintain possession of the sample. Sampling from the paver hopper is prohibited. Each sample will be divided into two 10,000 gram parts with one part being for initial testing and the other part being held for possible dispute resolution testing. Obtain a minimum of three samples for each mix type regardless of the number of days of production.

Obtain samples that are representative of the day's paving. Sample collection is to be spaced throughout the planned tonnage. One sample will be obtained in the first half of the tonnage and the second sample will be obtained in the second half of the tonnage. If planned paving is reduced or suspended, when paving resumes, the remaining sampling must be representative of the original intended sampling timing.

Ensure all persons performing testing are Bit Level One certified or Bit QA/QC Technician certified.

Ensure daily test samples are obtained, except, if the first test results show that the HMA mixture is in specification, the Engineer has the option of not testing additional samples from that day.

At the Pre-Production or Pre-Construction meeting, the Engineer and Contractor will collectively determine the test method for measuring asphalt content (AC) using *MTM 319 (Determination of Asphalt Content from Asphalt Paving Mixtures by the Ignition Method)* or *MTM 325 (Quantitative Extraction of Bitumen from HMA Paving Mixtures)*. Back calculation will not be allowed for determining asphalt content.

Ensure all labs performing local agency acceptance testing are qualified labs per the *HMA Production Manual* and participate in the MDOT round robin process, or they must be *AASHTO Materials Reference Laboratory (AMRL)* accredited for *AASHTO T 30* or *T 27*, and *AASHTO T 164* or *T 308*. Ensure on non-National Highway System (NHS) routes, Contractor labs are made available, and may be used, but they must be qualified labs as previously stated. Contractor labs may not be used on NHS routes. Material acceptance testing will be completed by the Engineer within 14 calendar days, except holidays and Sundays, for projects with less than 5,000 tons (plan quantity) of HMA and within 7 calendars days, except holidays and Sundays, for projects with 5,000 tons (plan quantity) or more of HMA, after the Engineer has obtained the samples. QA test results will be provided to the Contractor after the Engineer receives the QC test results. Failure on the part of the Engineer or the laboratory to provide Quality Assurance test results within the specified time frame does not relieve the Contractor of their responsibility to provide an asphalt mix within specifications.

The correlation procedure for ignition oven will be established as follows. Asphalt binder content based on ignition method from MTM 319. Gradation (*ASTM D 5444*) and Crushed particle content (*MTM 117*) based on aggregate from *MTM 319*. The incineration temperature will be established at the Pre-Production Meeting. The Contractor will provide a laboratory mixture sample to the acceptance laboratory to establish the correction factor for each mix. Ensure this sample is provided to the Engineer a minimum of 14 calendar days prior to production.

For production/mainline type paving, the mixture may be accepted by visual inspection up to a quantity of 500 tons per mixture type, per project (not per day). For non-production type paving defined as driveways, approaches, and patching, visual inspection may be allowed regardless of the tonnage.

The mixture will be considered out-of-specification, as determined by the acceptance tests, if for any one mixture, two consecutive tests per parameter, (for Parameter 2, two consecutive aggregate gradations on one sieve) are outside Range 1 or Range 2 tolerance limits. If a parameter is outside of Range 1 tolerance limits and the second consecutive test shows that the parameter is outside of Range 2, then it will be considered to be a Range 1 out-of-specification. Consecutive refers to the production order and not necessarily the testing order. Out-of-specification mixtures are subject to a price adjustment per the Measurement and Payment section of this special provision.

Contractor operations will be suspended when the mixture is determined to be out-of-specification, but contract time will continue to run. The Engineer may issue a Notice of Non-Compliance with Contract Requirements (Form 1165), if the Contractor has not suspended operations and taken corrective action. Submit a revised JMF or proposed alterations to the plant and/or materials to achieve the JMF to the Engineer. Effects on the Aggregate Wear Index (AWI) and mix design properties will be taken into consideration. Production and placement cannot resume until receipt of the Engineer's approval to proceed.

Pavement in-place density will be measured using one of two approved methods. The method used for measuring in-place density will be agreed upon at a pre-production or pre-construction meeting.

Pavement in-place density tests will be completed by the Engineer during paving operations and prior to traffic staging changes. Pavement in-place density acceptance testing will be completed by the Engineer prior to paving of subsequent lifts and being open to traffic.

Option 1 – Direct Density Method

Use of a nuclear density gauge requires measuring the pavement density using the Gmm from the JMF for the density control target. The required in-place density of the HMA mixture must be 92.0 to 98.0 percent of the density control target. Nuclear density testing and frequency will be in accordance with the *MDOT Density Testing and Inspection Manual*.

Option 2 – Roller Method

The Engineer may use the Roller Method with a nuclear or non-nuclear density gauge to document achieving optimal density as discussed below.

Use of the density gauge requires establishing a rolling pattern that will achieve the required in-place density. The Engineer will measure pavement density with a density gauge using the Gmm from the JMF for the density control target.

Use of the Roller Method requires developing and establishing density frequency curves, and meeting the requirements of Table 2. A density frequency curve is defined as the measurement and documentation of each pass of the finished roller until the in-place density results indicate a decrease in value. The previous recording will be deemed the optimal density. The Contractor is responsible for establishing and documenting an initial or QC rolling pattern that achieves the optimal in-place density. When the density frequency curve is used, the Engineer will run and document the density frequency curve for each half day of production to determine the number of passes to achieve the maximum density. Table 5, located at the end of this special provision, can be used as an aid in developing the density frequency curve. The Engineer will perform density tests using an approved nuclear or non-nuclear gauge per the manufacturer's recommended procedures.

Table 2: Minimum Number of Rollers Recommended Based on Placement Rate

Average Laydown Rate, Square Yards per Hour	Number of Rollers Required (a)	
	Compaction	Finish
Less than 600	1	1 (b)
601 - 1200	1	1
1201 - 2400	2	1
2401 - 3600	3	1
3601 and More	4	1

a. Number of rollers may increase based on density frequency curve.
b. The compaction roller may be used as the finish roller also.

After placement, roll the HMA mixture as soon after placement as the roller is able to bear without undue displacement or cracking. Start rolling longitudinally at the sides of the lanes and proceed toward the center of the pavement, overlapping on successive trips by at least half the width of the drum. Ensure each required roller is 8 tons minimum in weight unless otherwise approved by the Engineer.

Ensure the initial breakdown roller is capable of vibratory compaction and is a maximum of 500 feet behind the paving operations. The maximum allowable speed of each roller is 3 miles per hour (mph) or 4.5 feet per second. Ensure all compaction rollers complete a minimum of two complete rolling cycles prior to the mat temperature cooling to 180 degrees Fahrenheit (F). Continue finish rolling until all roller marks are eliminated and no further compaction is possible. The Engineer will verify and document that the roller pattern has been adhered to. The Engineer can stop production when the roller pattern is not adhered to.

d. Measurement and Payment. The completed work, as described, will be measured and paid for using applicable pay items as described in subsection 501.04 of the Standard Specifications for Construction, or the contract, except as modified below.

Base Price. Price established by the Department to be used in calculating incentives and adjustments to pay items and shown in the contract.

If acceptance tests, as described in section c. of this special provision, show that a Table 1 mixture parameter exceeds the Range 1, but not the Range 2, tolerance limits, that mixture parameter will be subject to a 10 percent penalty. The 10 percent penalty will be assessed based on the acceptance tests only unless the Contractor requests that the 10,000 gram sample part retained for possible dispute resolution testing be tested. The Contractor has 4 calendar days from receipt of the acceptance test results to notify the Engineer, in writing, that dispute resolution testing is requested. The Contractor's QC test results for the corresponding QA test results must result in an overall payment greater than QA test results otherwise the QA tests will not be allowed to be disputed. The Engineer has 4 calendar days to send the dispute resolution sample to the lab once dispute resolution testing is requested. The dispute resolution sample will be sent to an independent lab selected by the Local Agency, and the resultant dispute test results will be used to determine the penalty per parameter, if any. Ensure the independent lab is a MDOT QA/QC qualified lab or an AMRL HMA qualified lab. The independent lab must not have conflicts of interest with the Contractor or Local Agency. If the dispute testing results show that the mixture parameter is out-of-specification, the Contractor will pay for the cost of the dispute resolution testing and the contract base price for the material will be adjusted, based on all test result parameters from the dispute tests, as shown in Table 3 and Table 4. If the dispute test results do not confirm the mixture parameter is out-of-specification, then the Local Agency will pay for the cost of the dispute resolution testing and no price adjustment is required.

If acceptance tests, as described in section c. of this special provision, show that a Table 1 mixture parameter exceeds the Range 2 tolerance limits, the 10,000 gram sample part retained for possible dispute resolution testing will be sent, within 4 calendar days, to the MDOT Central Laboratory for further testing. The MDOT Central Laboratory's test results will be used to determine the penalty per mixture parameter, if any. If the MDOT Central Laboratory's results do not confirm the mixture parameter is out-of-specification, then no price adjustment is required. If the MDOT Central Laboratory's results show that the mixture is out-of-specification and the Engineer approves leaving the out-of-specification mixture in place, the contract base price for the material will be adjusted, based on all parameters, as shown in Table 3 and Table 4.

In the case that the Contractor disputes the results of the test of the second sample obtained for a particular day of production, the test turn-around time frames given would apply to the second test and there would be no time frame on the first test.

The laboratory (MDOT Central Laboratory or independent lab) will complete all Dispute Resolution testing and return test results to the Engineer, who will provide them to the Contractor, within 13 calendar days upon receiving the Dispute Resolution samples.

In all cases, when penalties are assessed, the penalty applies to each parameter, up to two parameters, that is out of specification.

Table 3: Penalty Per Parameter

Mixture Parameter out-of-Specification per Acceptance Tests	Mixture Parameter out-of-Specification per Dispute Resolution Test Lab	Price Adjustment per Parameter
NO	N/A	None
YES	NO	None
	YES	Outside Range 1 but not Range 2: decrease by 10%
		Outside Range 2: decrease by 25%

The quantity of material receiving a price adjustment is defined as the material produced from the time the first out-of-specification sample was taken until the time the sample leading to the first in-specification test was taken.

Each parameter of Table 1 is evaluated with the total price adjustment applied to the contract base price based on a sum of the two parameter penalties resulting in the highest total price adjustment as per Table 4. For example, if three parameters are out-of-specification, with two parameters outside Range 1 of Table 1 tolerance limits, but within Range 2 of Table 1 limits and one parameter outside of Range 2 of Table 1 tolerance limits and the Engineer approves leaving the mixture in place, the total price adjustment for that quantity of material is 35 percent.

Table 4: Calculating Total Price Adjustment

Cost Adjustment as a Sum of the Two Highest Parameter Penalties		
Number of Parameters Out-of-Specification	Range(s) Outside of Tolerance Limits of Table 1 per Parameter	Total Price Adjustment
One	Range 1	10%
	Range 2	25%
Two	Range 1 & Range 1	20%
	Range 1 & Range 2	35%
	Range 2 & Range 2	50%
Three	Range 1, Range 1 & Range 1	20%
	Range 1, Range 1 & Range 2	35%
	Range 1, Range 2 & Range 2	50%
	Range 2, Range 2 & Range 2	50%

Table 5: Density Frequency Curve Development

Tested by: _____ Date/Time: _____

Route/Location:		Air Temp:
Control Section/Job Number:		Weather:
Mix Type:	Tonnage:	Gauge:
Producer:	Depth:	Gmm:

Roller #1 Type: _____

Pass No.	Density	Temperature	Comments
1			
2			
3			
4			
5			
6			
7			
8			
Optimum			

Roller #2 Type: _____

Pass No.	Density	Temperature	Comments
1			
2			
3			
4			
5			
6			
7			
8			
Optimum			

Roller #3 Type: _____

Pass No.	Density	Temperature	Comments
1			
2			
3			
4			
5			
6			
7			
8			
Optimum			

Summary: _____

**DETAILED SPECIFICATION
FOR
BIKE HOOPS**

1 of 1

a. Description. This work consists of removing existing bike hoops, and placing new bike hoops in the areas shown on the plans.

b. Materials. Provide bike hoop materials as noted in the details. The materials will include the anchor bolts, nuts, washers, and all other hardware required for installation in accordance with the specifications herein, details included on the plans and per the manufacturer's recommendations.

Shop drawings from the manufacturer are to be submitted to the Engineer for approval prior to fabrication.

Furnish bike hoops with the following specifications:

1. All pipe and anchoring hardware materials are to be made of stainless steel.
2. Fabricate bike hoops as dimensioned on the plans
3. The bike hoop pipe is to be Schedule 40.
4. All anchoring bolts, nuts, washers, and all other hardware for installation to be stainless steel.

c. Construction Methods. Surface mounting is required in areas with poured concrete pavement. Install per manufacturers recommendations. Identify each part prior to assembly, only after final adjustment and leveling permanently tighten all bolt, nuts, and fasteners.

Evenly space bike hoops at the dimensions noted on plans. Bike hoops must be installed plumb and in line with each other, and shall be firmly connected to the foundation or pavement so as to prevent rocking.

Installation location to be verified and accepted by the engineer prior to installation.

d. Measurement and Payment. The completed work, as described, will be measured and paid for at the contract unit price using the following pay item:

<u>PAY ITEM</u>	<u>PAY UNIT</u>
Bike Hoops, Rem	Each
Bike Hoops, Surface Mount	Each

The unit price for this item of work shall include all labor, material, and equipment costs to perform all the work specified in this Detailed Specification.

Bike hoops noted for removal shall become the property of the Contractor. Bike Hoops, Rem shall also include properly disposing of bike hoops.

Bike Hoops, Surface Mount includes furnishing and installing the bike hoop and all associated hardware.

**DETAILED SPECIFICATION
FOR
REMOVING AND SALVAGING SIGNS**

1 of 1

a. Description. This work shall consist of removing, stockpiling and reinstalling historical information and wayfinding signage, as shown on the Plans, as shown in this Detailed Specification, and as directed by the Engineer.

b. Materials. Sand shall consist of Class II granular material in accordance with Section 902 of the 2012 MDOT Standard Specifications for Construction.

Concrete base shall be constructed of Grade P1 or PN-C concrete in accordance with Section 601 of the 2012 MDOT Standard Specifications for Construction.

Mounting hardware to match existing materials, or as specified.

c. Construction Methods. The Contractor shall carefully remove the existing signs, taking care not to damage or scratch the signs. Remove the existing bases and backfill the void with sand. Stockpile the signs in a safe location, as approved by the Engineer.

The contractor shall install new bases to match proposed finish grades, with proper mounting hardware. Prior to placing bases, verify final location with the Engineer.

The Contractor shall take any necessary precautions to prevent damage to signs during removal and replacement.

d. Measurement and Payment. Completed work as measured for this item of work will be paid for at Contract Unit Price for the following Contract Pay Item:

<u>PAY ITEM</u>	<u>PAY UNIT</u>
Sign, Rem and Salvage	Each

The unit price for this item of work shall include all labor, material, and equipment costs to perform all the work specified in the Standard Specifications and as modified by this Detailed Specification.

The pay item shall include the removal and disposal of concrete base; and furnishing and placing a new concrete base, and required sand.

Earthwork and placement of sand to be included in pay items included within the contract documents.

**DETAILED SPECIFICATION
FOR
TREES AND PLANTINGS**

AA:JN

1 of 2

4/30/17

DESCRIPTION

This work shall consist of planting deciduous trees in a planting medium, tree drip bags, and one season of watering and cultivating, at the locations shown on the plans and as directed by the Engineer.

MATERIALS

All planting methods and materials shall conform to Sections 815, 816 and 917 and the planting details shown on the plans. Tree types and sizes shall be as shown on the planting plans.

Planting medium shall be per City of Ann Arbor specifications.

Mulch shall consist of shredded hardwood clean of all debris and inorganic materials.

Tree drip irrigation bags are in addition to planting specifications 815, 816 and 917 of the 2003 Michigan Department of Transportation Standard Specifications.

Tree Drip Irrigation Bags shall be Treegator Original 20 gallon slow release watering bags available from John Deere Landscape @ Ann Arbor, 734-668-1020, Christensen's Plant Nursery, 734-454-1400, or approved substitution.

Fertilizer shall be slow release, at minimum 50% derived from a natural, organic source, 12-0-6 or approved substitution.

The contractor shall submit a minimum size sample of ½ gallon-sized container of structural soil and topsoil for approval prior to installation.

The CONTRACTOR shall submit to the ENGINEER sources for all plant material 30 (thirty) days after contract award and submit an invoice following purchase and delivery of the plants.

CONSTRUCTION METHODS

The construction methods shall be in accordance with the 2003 Michigan Department of Transportation Standard Specifications for Construction Section 815.03 and 816.03 unless otherwise stated in this special provision.

All open tree pits shall be excavated to the full extent of their dimensions as shown in the details. Place planting mix as directed, with minimal compaction.

Watering and Cultivating shall follow the schedule in the 2012 Michigan Department of Transportation Standard Specifications for construction section 815 with the adjustment of filling the tree drip irrigation bags with water and using the fertilizer as dictated in this special provision. For each watering and cultivating visit, verification in the form of a report of maintenance activities and certified payroll covering visits, shall be provided to the OWNER by the end of each month that the visits have taken place.

**DETAILED SPECIFICATION
FOR
TREES AND PLANTINGS**

AA:JN

2 of 2

4/30/17

MEASUREMENT AND PAYMENT

The completed work as measured shall be paid for at the contract unit price for the following contract items (pay items):

<u>Pay Item</u>	<u>Pay Unit</u>
Nyssa Sylvatica (Blackgum) 2.5 inch B-B	Each
Ulmus Americana New Marmomy (American Elm)	Each

Measurement and payment for the items shall include excavation, backfill, topsoil, shredded bark mulch, planting mix, tree drip irrigation bags, water, and all other equipment necessary, and as described herein, for a complete installation. Watering and Cultivating for one season shall also be included in this this item.

The final inspection of all planting work under the Contract will be made by the contractor and Engineer at the end of the maintenance and establishment periods. Before final acceptance is given, the terms of the establishment shall be met and the site shall be cleared of all debris, soil piles and containers.

**DETAILED SPECIFICATION
FOR
TREE GRATE**

1 of 2

a. Description. This work consists of furnishing and installing cast iron tree grates and their frames.

b. Materials. Concrete to conform to section 601 of the Standard Specifications for Construction.

Provide iron castings conforming to section 908 of the Standard Specifications for Construction.

Tree Grate Casting and frame to be model #8679 "Boardwalk", as manufactured by East Jordan Iron Works (EJ) of East Jordan, Michigan (phone is 800-874-4100). Contractor is to provide the specified tree grate casting and frame, or an equal product approved by the Engineer. Tree grates and frames are to be 48 inches by 96 inches with an 18-inch square tree opening, black asphaltic coated finish, with openings slots in a pattern that conforms to ADA guidelines.

Ensure all anchoring bolts, nuts, washers, and all other hardware for installation meet the manufacturer's recommendation.

Furnish certification regarding the compliance of materials incorporated in the work, for approval by Engineer prior to installation.

c. Construction Methods.

A. Fabrication

1. Ensure all tree grate castings are manufactured true to pattern and component parts must fit together in a uniform manner.
2. Ensure castings are free of all defects and cleaned by shot blasting.
3. Furnish tree grates and frames without paint or primer.

B. Installation

1. Square up the frame sections and bolt them together. Install the tree grate frame flush and on a plane with the proposed surrounding slope, prior to casting the concrete around it.
2. Pour concrete header to the dimensions required to accept frame.
3. Set the grates flush with the top of the frame and ensure that the grate does not rock in the frame. Securely bolt grate halves together on the underside. Clean any foreign matter from the grates prior to setting.
4. If the engineer believes that the product or the installation has resulted in either a poorly fitted grate and frame, an unsafe walking surface, or an unacceptable amount of rocking, they may reject the installed product, and require a new installation and/or a new tree grate.

**DETAILED SPECIFICATION
FOR
TREE GRATE**

2 of 2

d. Measurement and Payment. The completed work, as described, will be measured and paid for at the contract unit price using the following pay item:

PAY ITEM

PAY UNIT

Tree Grate

Each

The unit price for this item of work shall include all labor, material, and equipment costs to perform all the work specified in this Detailed Specification.

The work includes furnishing and installing the tree grates and all associated hardware, and furnishing and placing materials to complete the concrete header.

**DETAILED SPECIFICATION
FOR
STREET LIGHT FOUNDATION**

1 of 1

a. Description. This work shall include the light pole foundation, grounding, anchor bolts, steel reinforcement, conduit, excavation, backfill, and all related items of work as shown on the Plans, as detailed in the Specifications, and as directed by the Engineer, in accordance with Section 819 of the 2012 MDOT Standard Specifications for Construction, City of Ann Arbor Standard Specifications, except as specified herein, and as directed by the Engineer.

b. Materials. All materials shall comply with Section 819 of the 2012 MDOT Standard Specifications for Construction, City of Ann Arbor Standard Specifications, except as specified herein, and as directed by the Engineer.

c. Construction. Contractor shall provide all labor, equipment and materials to bore, remove and dispose of spoils, and install a complete pole foundation, including grounding, anchor bolts, leveling and plumbing of the sonnet tube. Provide 4000 PSI concrete foundations. Protect foundations. Grout and backfill along the foundations with suitable excavated material. Dispose of the materials not required. Protect the open hole during construction.

d. Measurement and Payment. The completed work as measured for these items of work will be paid for at the Contract Unit Price for the following Contract (Pay) Items:

<u>PAY ITEM</u>	<u>PAY UNIT</u>
Street Light Foundations LTFX-1	Each
Street Light Foundations LTFX-2	Each

The unit price for these items of work shall include all labor, material, and equipment costs to perform all the work specified in the Standard Specifications and as modified by this Detailed Specification.

All costs associated with shifting of the pole locations to accommodate adjacent finished surface elements and joint lines as indicated on the plans shall be included in the unit price cost.

All costs associated with the grouting, backfilling, and compaction along the foundations with suitable excavated material following foundation installation shall be included in the unit price cost.

**DETAILED SPECIFICATION
FOR
STREET LIGHT ASSEMBLY**

1 of 1

a. Description. This work shall include the installation of new single and twin light fixture poles and associated electrical. All items of work as shown on the Plans, as detailed in the Specifications, and as directed by the Engineer, in accordance with sections 819 and 918 of 2012 MDOT Standard Specifications for Construction, City of Ann Arbor Standard Specifications, except as specified herein, and as directed by the Engineer. Reference the City of Ann Arbor Specifications, DIVISION VI, STREETLIGHT INSTALLATION AND CONSTRUCTION.

b. Materials. Lamp posts to be manufactured by Spring City Electrical Manufacturing Co. as shown in the attached details. Posts shall support one and two luminaires. Luminaires are LED globes that are Owner Furnished Contractor Installed.

c. Construction. Contractor shall provide all labor, material and equipment necessary to provide all branch circuit wiring and conduit revisions for the new poles and appropriate number of luminaires. Provide and install the pole, pole handhole, weatherproof receptacle, ground and ground rod. Locate ground rod in the grade box (handhole). Orientate receptacles and pole handhole away from roadway. Twin luminaires shall be oriented parallel to the road. Make all electrical connections to the conductors and ground for the receptacle. Install and provide fusing in pole and make all wiring connections as necessary.

d. Measurement and Payment. The completed work as measured for this item of work will be paid for at the Contract Unit Price for the following Contract (Pay) Item:

<u>PAY ITEM</u>	<u>PAY UNIT</u>
Street Light Assembly, Complete LTFX-1	Each
Street Light Assembly, Complete LTFX-2	Each

The unit price for these items of work shall include all labor, material, and equipment costs to perform all the work specified in the Standard Specifications and as modified by this Detailed Specification.

The unit price for Street Light Assembly, Complete LTFX-1 shall include furnishing and installing a single luminaire lamp post, in addition to all materials to make complete, including a single owner furnished luminaire.

The unit price for Street Light Assembly, Complete LTFX-2 shall include furnishing and installing a twin luminaire lamp post, in addition to all materials to make complete, including two owner furnished luminaires.

This drawing is property of Spring City Elect. Mfg. and is issued to the recipient with the understanding that it shall not be copied, duplicated, passed on to unauthorized parties, nor used for any purpose other than that for which it is specifically furnished except with Spring City's written permission.

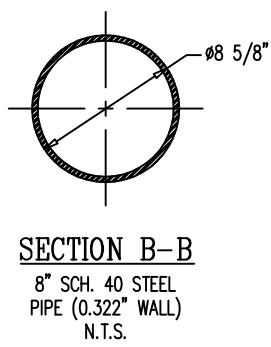
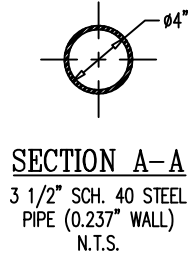

LAMP POST SPECIFICATIONS

STYLE: CENTER CITY WITH STEEL SHAFT ASSEMBLY
 HEIGHT: 11'-2"
 BASE: 18" DIAMETER
 MATERIAL:
 SHAFT: 8" SCH 40 STEEL PIPE PEDESTAL (8 5/8" O.D.)
 4" SCH 40 STEEL PIPE SHAFT (4" O.D.)
 ORNAMENTATION: (2) TWO PIECE WRAP AROUND CASTINGS, CAST DUCTILE IRON PER A.S.T.M. A536-84, GRADE 65-45-12
 FINISH: POWDER COATED - GLOSS BLACK
 ACCESS DOOR: SECURED WITH 1/4"-20 HEX HEAD BOLT (18-8)
 GROUND PROVISIONS: INSIDE WALL, OPPOSITE ACCESS DOOR, TO BE DRILLED AND TAPPED FOR 1/4"-20 GROUND PROVISION (GROUND LUG SUPPLIED BY SPRING CITY)
 ANCHOR BOLTS: (4) 1" DIA. X 30" + 4" HOOK (FULLY GALVANIZED WITH 2 GALVANIZED NUTS AND 2 GALVANIZED WASHERS PER BOLT)
 BOLT PROJECTION: 3" REQUIRED
 TENON: 2 7/8" DIA. X 3" HIGH (TO ACCEPT LUMINAIRE)
 COATING: FABRICATED STEEL STRUCTURE (AFTER ASSEMBLY), DUCTILE IRON AND ALUMINUM CASTINGS TO BE GALVANIZED

CATALOG NO.: SPSCCD-SC4-18-11.20-TN2.88/3.00-(4)BP-PP-GFWI-CU

WARRANTY INFORMATION

TWO PIECE CAST DUCTILE IRON CASTINGS PROTECTED BY SPRING CITY'S 25 YEAR WARRANTY.

SPRING CITY WARRANTS ITS DUCTILE IRON BASES TO BE FREE FROM DEFECTS IN MATERIALS AND WORKMANSHIP UNDER NORMAL USE AND OPERATION FOR 25 YEARS. NORMAL USE INCLUDES DAMAGE RESULTING FROM MOTOR VEHICLE COLLISIONS.

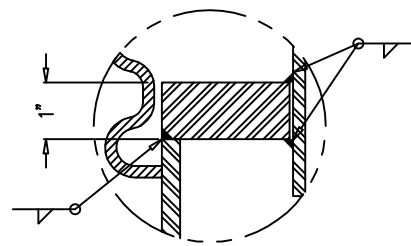
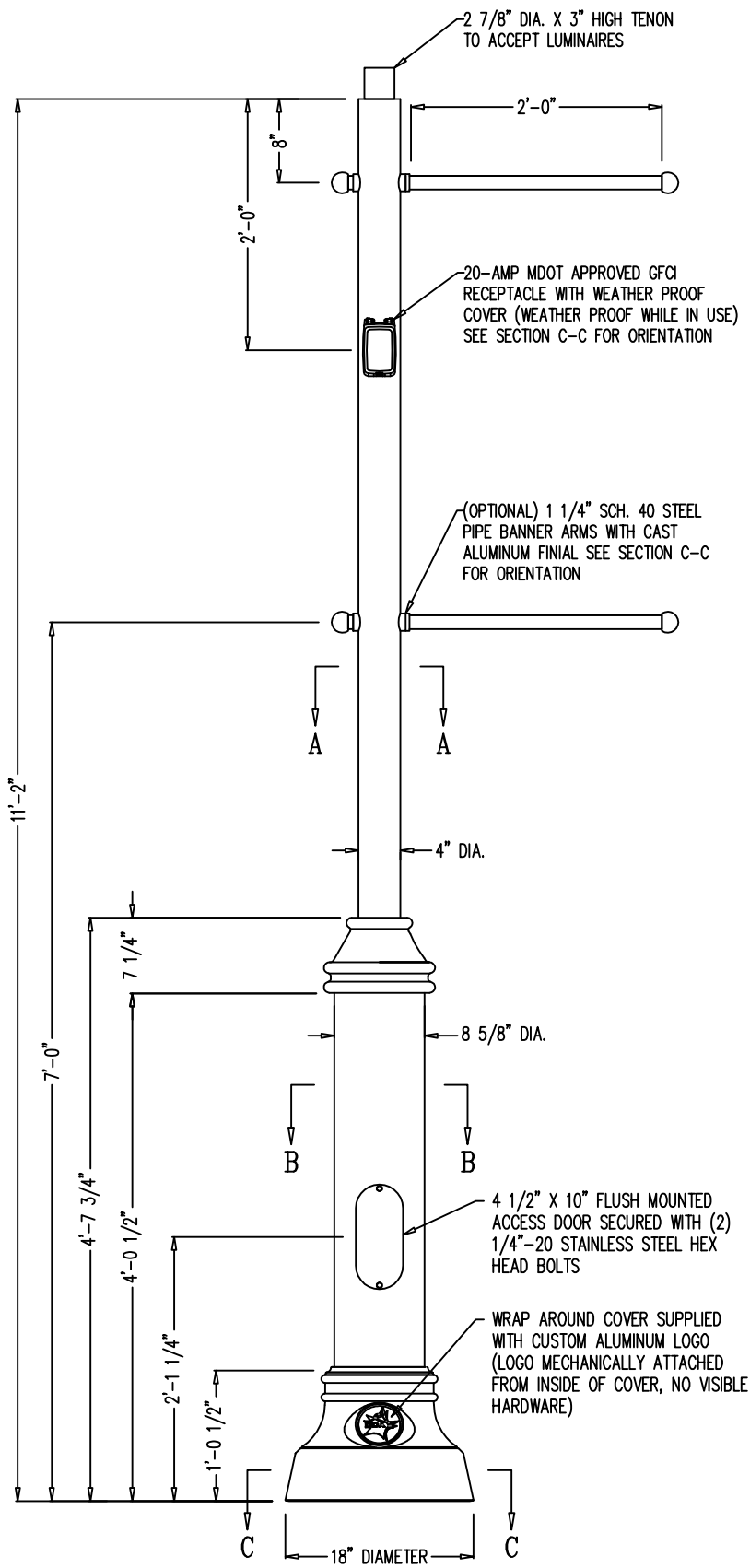

DETAIL A
STEEL ASSEMBLY DETAIL
N.T.S.

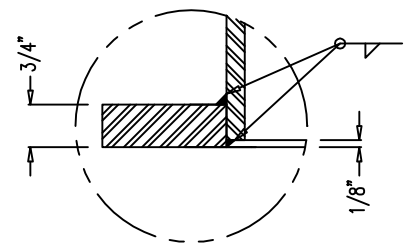

DETAIL B
STEEL ASSEMBLY DETAIL
N.T.S.

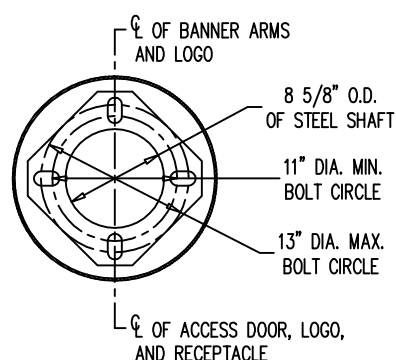
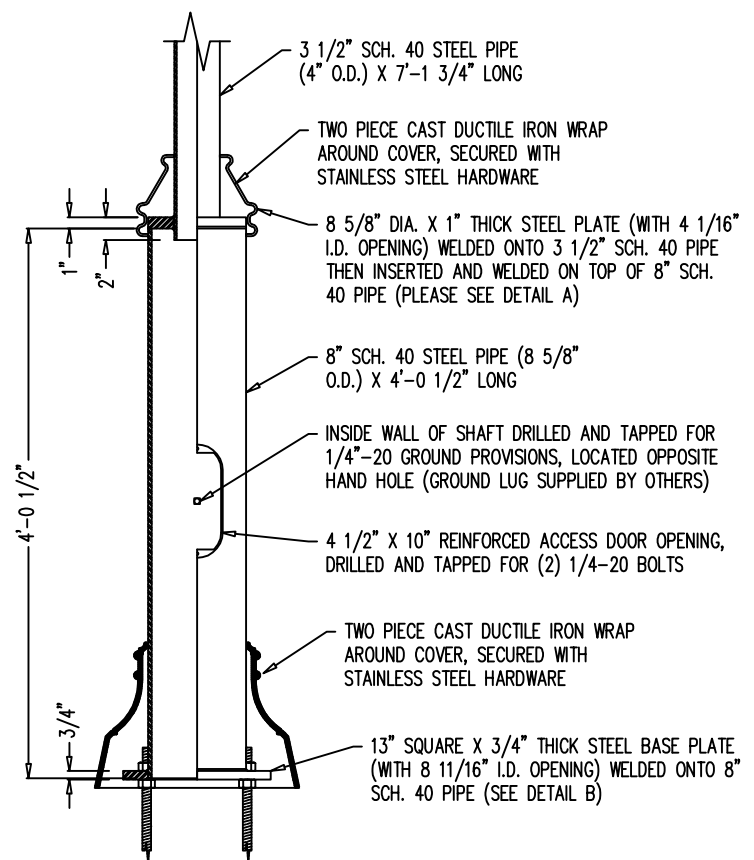

SECTION C-C
N.T.S.



Spring City Electrical Mfg. Co.

HALL AND MAIN STREETS - P.O. BOX 19 - SPRING CITY, PA. 19475
 PHONE (610) 948-4000 - FAX (610) 948-5577 - WWW.SPRINGCITY.COM

DESCRIPTION	THE 11'-2" CENTER CITY STYLE LAMP POST WITH WELDED STEEL ASSEMBLY AND CAST DUCTILE IRON ORNAMENTATION		
CUSTOMER	LIBERTY (ANN ARBOR, MI)		
JOB	LIBERTY (ANN ARBOR, MI)		
SCALE	DRAWN BY:	DATE	DRAWING NO.
N.T.S.	D.A.K.	03-31-2017	S103376

This drawing is property of Spring City Elect. Mfg. and is issued to the recipient with the understanding that it shall not be copied, duplicated, passed on to unauthorized parties, nor used for any purpose other than that for which it is specifically furnished except with Spring City's written permission.

LAMP POST SPECIFICATIONS

STYLE: CENTER CITY WITH STEEL SHAFT ASSEMBLY
 HEIGHT: 13'-0"
 BASE: 18" DIAMETER
 MATERIAL:
 SHAFT: 8" SCH 40 STEEL PIPE PEDESTAL (8 5/8" O.D.)
 4" SCH 40 STEEL PIPE SHAFT (4" O.D.)
 ORNAMENTATION: (2) TWO PIECE WRAP AROUND CASTINGS, CAST DUCTILE IRON PER A.S.T.M. A536-84, GRADE 65-45-12
 FINISH: POWDER COATED - GLOSS BLACK
 ACCESS DOOR: SECURED WITH 1/4"-20 HEX HEAD BOLT (18-8)
 GROUND PROVISIONS: INSIDE WALL, OPPOSITE ACCESS DOOR, TO BE DRILLED AND TAPPED FOR 1/4"-20 GROUND PROVISION (GROUND LUG SUPPLIED BY SPRING CITY)
 ANCHOR BOLTS: (4) 1" DIA. X 30" + 4" HOOK (FULLY GALVANIZED WITH 2 GALVANIZED NUTS AND 2 GALVANIZED WASHERS PER BOLT)
 BOLT PROJECTION: 3" REQUIRED
 TENON: 3 1/2" DIA. X 6" HIGH (TO ACCEPT CROSS ARM)
 COATING: FABRICATED STEEL STRUCTURE (AFTER ASSEMBLY), DUCTILE IRON AND ALUMINUM CASTINGS TO BE GALVANIZED
 CATALOG NO.: SPSCCD-SC4-18-13.00-TN3.50/6.00-PP-GFWI-CU

CROSS ARM SPECIFICATIONS

STYLE: ANN ARBOR TWIN
 HEIGHT: 10"
 WIDTH: 22" FROM ϕ TO ϕ
 MATERIAL: FABRICATED ALUMINUM
 FINISH: POWDER COAT - GLOSS BLACK
 TENON: 2 7/8" DIA. X 3" HIGH (TO ACCEPT LUMINAIRE)
 CATALOG NO.: AARANN-2S-22-TN2.88/3.00-CU

WARRANTY INFORMATION

TWO PIECE CAST DUCTILE IRON CASTINGS PROTECTED BY SPRING CITY'S 25 YEAR WARRANTY.

SPRING CITY WARRANTIES ITS DUCTILE IRON BASES TO BE FREE FROM DEFECTS IN MATERIALS AND WORKMANSHIP UNDER NORMAL USE AND OPERATION FOR 25 YEARS. NORMAL USE INCLUDES DAMAGE RESULTING FROM MOTOR VEHICLE COLLISIONS.

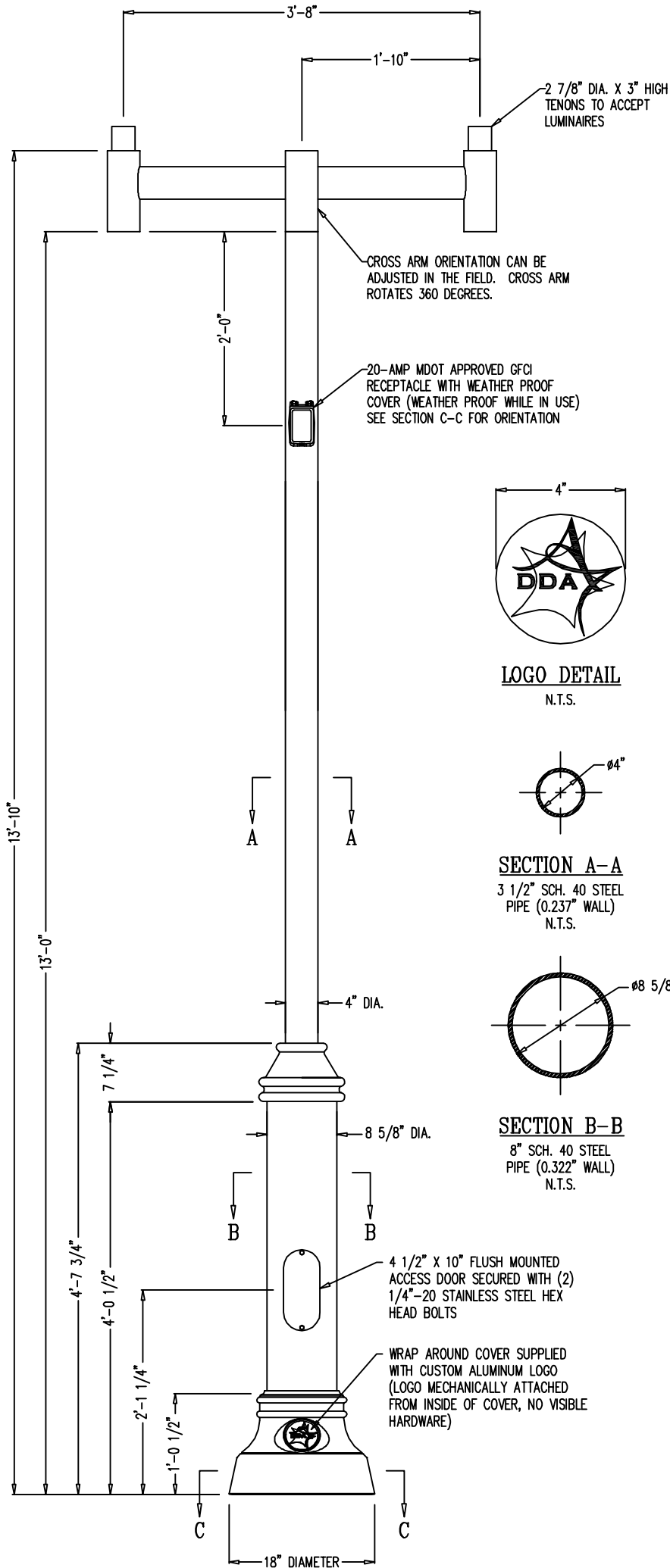

LOGO DETAIL
N.T.S.

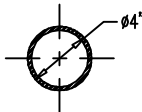

SECTION A-A
3 1/2" SCH. 40 STEEL PIPE (0.237" WALL)
N.T.S.

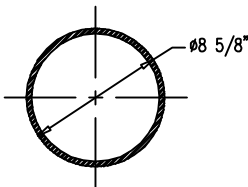

SECTION B-B
8" SCH. 40 STEEL PIPE (0.322" WALL)
N.T.S.

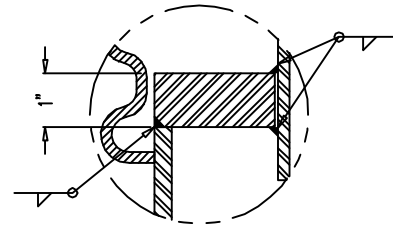

DETAIL A
STEEL ASSEMBLY DETAIL
N.T.S.

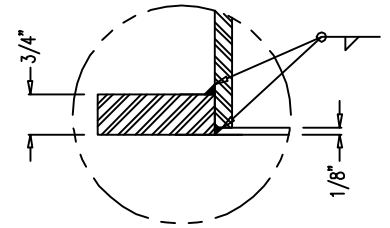

DETAIL B
STEEL ASSEMBLY DETAIL
N.T.S.

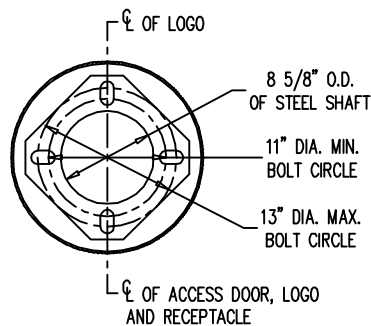
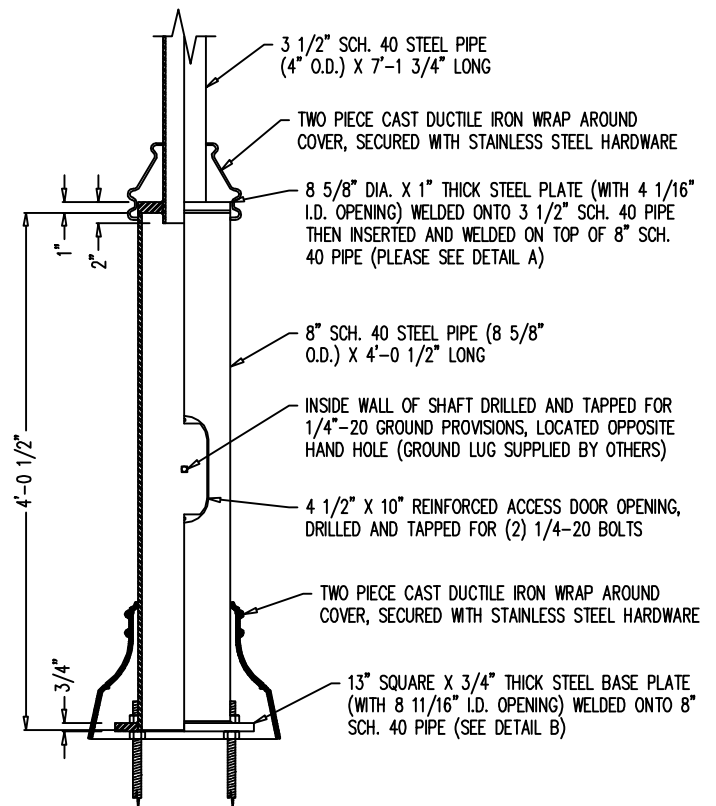

SECTION C-C
N.T.S.



Spring City Electrical Mfg. Co.

HALL AND MAIN STREETS - P.O. BOX 19 - SPRING CITY, PA. 19475
 PHONE (610) 948-4000 - FAX (610) 948-5577 - WWW.SPRINGCITY.COM

DESCRIPTION	THE 13'-0" CENTER CITY STYLE LAMP POST WITH WELDED STEEL ASSEMBLY AND CAST DUCTILE IRON ORNAMENTATION AND A TWIN ANN ARBOR CROSS ARM		
CUSTOMER	LIBERTY (ANN ARBOR, MI)		
JOB	LIBERTY (ANN ARBOR, MI)		
SCALE	DRAWN BY:	DATE	DRAWING NO.
N.T.S.	D.A.K.	03-31-201	S103375

MICHIGAN
DEPARTMENT OF TRANSPORTATION

SUPPLEMENTAL SPECIFICATION
FOR
ERRATA TO THE 2012 STANDARD SPECIFICATIONS

1 of 30

03-07-17

Page	Subsection	Errata
3	101.02	Modify the abbreviation reading "AIS" to read "AISI".
4	101.02	Delete the following abbreviations and the long forms MDELEG MDNRE Add the following abbreviations and the long forms MDNR Michigan Department of Natural Resources MDEQ Michigan Department of Environmental Quality MDLARA Michigan Department of Licensing and Regulatory Affairs NESC National Electrical Safety Code
27	103.02.B.2	Change the last sentence of the first paragraph to read "For decreases below 75 percent, the maximum allowable payment for work performed, including any adjustment, will not exceed an amount equal to 75 percent of the original contract quantity times the contract unit price."
34	104.05	The first sentence of this subsection should read "If the Contractor performs unauthorized work (work performed without the inspections required by the contract, extra work performed without Department approval, work performed contrary to the inspectors direction, or work performed while under suspension by the inspector), the Engineer may reject the unauthorized work."
46	104.12	Add the following to the end of the first paragraph "The use of right-of-way in wetlands and floodplains, or the crossing of water courses by construction equipment is prohibited."
53	105.09	Add the following to the end of the second paragraph "Any specifically produced material not purchased by the Department, will remain the Contractors and must be removed from the project prior to final acceptance."
56	107.02.B.2	This sentence should read "U.S.Army Corps of Engineers' Section 404, Dredge and Fill; and Section 10, Navigable Waterway."
56	107.02.B	Add the subsection reading as follows: "3. U.S. Coast Guard Section 9, Navigable Waterway." Change "MDNRE" to "MDEQ" in this subsection.

- 64 107.12 Change the first sentence of the first paragraph to read:
 “For protection of underground utilities and in accordance with 2013 PA 174, the Contractor must notify Miss Dig at least 3 work days, excluding Saturdays, Sundays and holidays, before beginning each excavation in areas where public utilities have not been previously located.”
- 65 107.15.A Change "MDNRE" to "MDEQ" in four instances in this subsection.
- 66 107.15.A.3 Add the following to the end of the paragraph "Note that a burn permit from the MDNR is required for any open burning whenever the ground is not snow covered. Any individuals that allow a fire to escape will be in violation of the Natural Resources and Environmental Protection Act and will be required to reimburse the costs of suppressing the wild fire."
- 67* 107.16 The third sentence should read "In State Forests, the Contractor must contact the local Unit Manager, Forest Management Division, MDNR, regarding the work to be performed within or adjacent to the forest land."

 Delete the last sentence of the first paragraph of this subsection.
- 80 108.08.F Delete the second paragraph in its entirety.
- 80 108.08.G Add the following new subsection:
 “G. The Contractor may propose and the Engineer may approve another equitable method, supported by an acceptable rationale to determine time extensions for any of the excusable delays listed in subsection 108.08.
- 83 108.10.C Change the last sentence of the first paragraph to read:
 “The liquidated damages may contain one or more components of damages added together.”
- 83 108.10.C.1 In Table 108-1 delete the last row of the table and replace it with the following:

≥50,000,000	4,500
-------------	-------
- 102 109.05.E.1 Change the second sentence of the third paragraph to read:
 “Provide the content specified in subsection 109.05.D.11 for the applicable items in this statement and as follows:”
- 107 150.04 Change the following pay item reading “Mobilization, Max ___” to read “Mobilization, Max (dollar)” at nine locations throughout the subsection.
- 112 201.03.A.3.b Change "MDNRE" to "MDNR" in three instances in this subsection.
- 150 208.01 Change "MDNRE" to "MDEQ" in this subsection.
- 180 308.03.A Change the first sentence of the second paragraph to read:

- “Do not operate equipment required to place backfill directly on geotextile products.”
- 185 401.03.A Change the first sentence of the second paragraph to read:
Where unstable soil conditions, or obstructions other than rock, require excavation of the trench below the elevation detailed on the plans; undercut, backfill, and compact the trench as directed by the Engineer.
- 188 401.03.H Change the second sentence of the paragraph to read “Jack steel pipes in place in accordance with subsection 401.03.G”.
- 189 401.03.N Add the following sentence to the end of the first paragraph "Where possible, maintain the stream flow thru a temporary channel or temporary culvert."

The second sentence of the second paragraph should read "Direct water from the dewatering operations through a filter bag before discharging to an existing drainage facility."
- 190 401.04 Change the fourth pay item from the end of the list to read as follows:
“Steel Casing Pipe, __ inch, Tr Det __.”
- 195 402.03.C Change the third sentence of the first paragraph to read as follows:
“Wrap pipe joints, with a diameter greater than 24 inches, using geotextile blanket.”
- 200 402.04 Change the third pay item from the top of the list to read as follows:
“Sewer, CI __, __ inch, Jacked in Place”
- 200 402.04.A Change the last sentence of the subsection to read as follows:
“The unit price for **Sewer** and **Sewer, Reinf Conc, Ellip** includes the cost of excavation, backfill, geotextile blanket and mandrel testing.”
- 201* 402.04.H Change the last sentence of the first paragraph to read "The Department will not make an adjustment in the pay items of **Minor Traf Devices** or **Traf Regulator Control**."
- 208 403.04.D.3 Change the sentence to read:
“Removing and replacing pavement adjacent to the adjusted cover per Standard Plan R-37 Series.”
- 218 406.03.A.2 Change the first sentence of the first paragraph to read:
“Design precast box culverts less than 10 feet in span length measured along the centerline of the roadway in accordance with current AASHTO LRFD Bridge Design Specifications and ASTM C 1577.”

Add the following sentence to the end of the first paragraph:
“Design precast box culverts greater than or equal to 10 feet in span length measured along the centerline of the roadway for HL-93 Modified live load.”

- 219 406.03.B Change the first sentence of the first paragraph to read:
 “Submit shop drawings for culverts greater than or equal to 10 feet in span length measured along the centerline of the roadway to the Engineer, for review and approval in accordance with subsection 104.02.”
- 219 406.03.C.1 Change the second sentence of the first paragraph to read:
 “Before manufacture, perform load ratings on precast three-sided, arch or box culverts greater than or equal to 10 feet in span length measured along the centerline of the roadway, in accordance with the AASHTO Manual of Bridge Evaluation, Section 6, Part A, the Michigan Bridge Analysis Guide current at the time load rating is performed, and the Michigan Structure Inventory and Appraisal Guide.”
- 223 406.03.G Add the following after the first sentence of the second paragraph:
 “Where possible, maintain the stream flow thru the existing channel, temporary channel, or temporary culvert.”
- 224 406.03.G Replace the fifth paragraph of this subsection with the following:
 “The Contractor may use cast-in-place wing walls, headwalls, and aprons, as alternatives to precast wing walls, headwalls, and aprons. Attach cast-in-place wing walls or headwalls as shown on the shop drawings.”
- 225 406.03.G.2 Change the third sentence of the first paragraph to read:
 “Before placing the open-graded aggregate 34R, compact the coarse aggregate 6A using at least three passes of a vibrating plate compactor.”
- 226 406.03.G.2 Change the first sentence of the second paragraph of this subsection to read:
 "Fill the space between the box culvert joints during placement of box sections with closed-cell rubber extrusion type gaskets in accordance with ASTM C 990."
- 226 406.04.A.9 Change the sentence to read:
 “Providing plan modifications including design, additional plan quantities and pay items to accommodate any changes to the precast units as shown on the plans.”
- 226* 406.04.A Add the following paragraph after the last paragraph of the subsection:
 “The substructure design is specific to the three-sided or arch culvert detailed on the plans. The Contractor must use approved MDOT service vendors qualified in Hydraulics, Geotechnical Engineering Services, and Short and Medium Span Bridges to perform the required design and plan modifications, as directed by the Engineer, if the Contractor selects a culvert shape different than shown on the plans.”
- 227 406.04.B Add the following new item in the list of items in this subsection:

2. Headwalls, wingwalls, aprons, and curtain walls, precast or cast-in-place;

Renumber the exist items 2 through 4 in this list to read 3 through 5.

Delete existing item numbered 5 and replace with the following:

6. Inserts for bars and connection hardware; and

Renumber the existing item 6 in this list to read 7.

- | | | |
|-----|------------|--|
| 227 | 406.04.B | Delete the first and second paragraphs following the list of items in this subsection and replace with the following:
"The Department will pay separately for cast-in-place concrete, other than for culvert segments, wing walls, and headwalls; excavation; protective coating; providing and placing backfill material; by plan quantity in accordance with subsection 109.01.A." |
| 239 | 501.03.C.6 | The first sentence of this subsection should read "Except as specified in subsection 501.03.C.4, removing HMA surface applies to removing HMA overlying a material designated for removal or that is required to remain in place." |
| 247 | 501.03.O | Change footnote e in Table 501-5 to read:
"Flushing severe enough to significantly affect surface friction (Friction Number <35)." |
| 249 | 501.04.H | The first sentence of this subsection should read "The Engineer will measure, and the Department will pay for removing HMA surface, no greater than 12 inches thick, overlying a material designated for removal or that is required to remain in place, as HMA Surface, Rem. "

The second paragraph of this subsection should read "The Engineer will measure, and the Department will pay for removing HMA surface, greater than 12 inches thick, overlying a material designated for removal or that is required to remain in place, as Pavt, Rem in accordance with subsection 204.04." |
| 257 | 503.03.E | Delete this subsection in its entirety. |
| 265 | 504.03.E.3 | Delete this subsection in its entirety. |
| 269 | 504.04.A | This subsection should read "The unit prices for Micro-Surface , regardless of the type required, include cleaning existing pavement; applying a bond coat; temporary pavement markings; stationing; corrective action; and traffic control to complete corrective action." |
| 299 | 601.04 | In table 601-2 delete the row for Grade P-NC concrete in its entirety. |
| 300 | 601.04 | In table 601-2, the first sentence of footnote b. should read:
"Use coarse aggregate 6A, 6AA or 6AAA for Grades P1, P2 and M." |

		countersunk screws with 3/4-inch or 1/2-inch diameter inserts for use in expansion joint cover plates."
389	706.03.D.4.b	Change the first sentence of the fourth paragraph to read "Design forms, form supports, and attachments to carry dead loads, and resultant horizontal loads due to forming of cantilever overhangs."
390	706.03.E.4	Change the fourth sentence of the first paragraph to read: "Use wire ties to secure all bar intersections for the top mat. Use wire ties to secure all bar intersections for other mats where the product of the length and width of bar intersection spacing exceeds 120 square inches."
391	706.03.E.8	Change the first sentence of the second paragraph of this subsection to read: "Patch sawed or sheared ends and visible defects in accordance with ASTM A 775."
392	706.03.E.8	Change the last sentence of the third paragraph of this subsection to read: "Coat mechanical splices after splice installation in accordance with ASTM A 775 for patching damaged epoxy coating."
394	706.03.H.1	Delete the last paragraph on page 394 and replace it with the following: "Do not cast sidewalk, curb, or barrier pours until the deck concrete attains at least the minimum specified 7-day flexural or compressive strength, and after completion of the 7-day continuous wet cure. The forming of succeeding portions may occur, provided the wet cure is maintained."
406*	706.03.N.1.b	Add the following to the end of the last paragraph of the subsection: "Do not discontinue wet cure nor cast succeeding portions onto the bridge deck prior to completion of the 7-day two-phase continuous wet cure. Ensure excess or ponding cure water is removed prior to casting of succeeding structure portions."
416	707.03.C.1	Change the title of the subsection from "Shop Plans to read "Shop Drawings". Change the second sentence of this subsection to read: "Do not use design drawings in lieu of shop drawings."
426	707.03.C.17	Change the second sentence in the first paragraph of this subsection to read: "Tap oversized galvanized nuts in accordance with ASTM A 563 or AASHTO M 292 and meet Supplementary Requirement S1 of ASTM A 563 or AASHTO M 292."
430	707.03.D.7.b	Delete the first sentence of the last paragraph of this subsection.

430*	707.03.D.7.b	Change the title of the Table 707-4 to read: "Minimum Bolt Tension for ASTM F 3125 Grade A 325"
430	707.03.D.7.b	Change "104,000" to "103,000" in the last row under the column titled Minimum Bolt Tension.
431	707.03.D.7.c	Add the following sentence to the end of the first paragraph of this subsection: "If using impact wrenches, provide wrenches sufficient to tighten each bolt in approximately 10 seconds."
431*	707.03.D.7.c	Change the first sentence of the second paragraph to read: "Do not reuse ASTM F 3125 Grade A 325 bolts and nuts.."
434	707.04.A	Change the first sentence of the first paragraph of this subsection to read: "The Engineer will measure structural steel by the calculated weight of metal in the finished structure, excluding filler metal in welding, as shown on the shop drawings or working drawings."
438	708.03.A.2	Change the title of the subsection from "Shop Plans to read "Shop Drawings". Change the first sentence to read: "Submit shop drawings in accordance with subsection 104.02." Change the fourth sentence to read: "Do not start production until the Engineer approves the shop drawings."
441*	708.03.A.11	Change the last sentence of the first paragraph to read "Cure concrete at temperatures from 70 °F to 150 °F until concrete attains the release strength shown on the shop drawings".
441	708.03.A.11	Change the fourth sentence of the fourth paragraph to read "Do not exceed a maximum concrete temperature of 150 °F during the curing cycle."
458	711.03.A	Change the first sentence in the first paragraph to read: "Shop drawings for structural steel and pipe railings are not required."
460	711.04.A	Change the second sentence of the first paragraph to read: "The unit price for Bridge Barrier Railing includes the cost of placing steel reinforcement, providing and placing concrete, constructing joints, and forming, finishing, curing and protecting the concrete."
461	711.04.F	The title of this subsection should read " Reflective Marker, Permanent Barrier. "
467	712.03.C	Add the following to the end of the third paragraph of the subsection:

“Notify the Engineer of any saw cuts in the top flange. Saw cuts equal to or less than 1/32 inch deep in steel beams must be repaired by grinding, to a surface roughness no greater than 125 micro-inches per inch rms, and tapering to the original surface using a 1:10 slope. Saw cuts in excess of 1/32 inch deep in steel beams require a welded repair to be submitted to the Engineer for approval. Weld in accordance with subsection 707.03.D.8 and provide adequate notice to allow the Engineer to witness the repair work. Inspect and test all saw cut repairs (including grinding repairs) using ultrasonic testing in accordance with 707.03.D.8.c at no additional cost to the Department.”

- | | | |
|------|------------|---|
| 471 | 712.03.J | Add the following to the end of the second paragraph of the subsection:
“Select adhesive anchor systems from the Qualified Products List.” |
| 471 | 712.03.J.1 | Delete the first paragraph in this subsection and replace it with the following: “Propose complete details of drilling, cleaning, and bonding systems for anchoring reinforcement and submit for the Engineer’s approval before use. The minimum embedment depth must be nine times the anchor diameter for threaded rod or bolt and twelve times the anchor diameter for reinforcing bar. Propose a drilling method that does not cut or damage existing reinforcing steel. Prepare at least three proof tests per anchor diameter and type in the same orientation in which they will be installed on the existing structure, on a separate concrete block, in the presence of the Engineer. The Engineer will proof test the proposed systems. The Engineer will base approval of the anchoring system on the following criteria:” |
| 471 | 712.03.J.2 | Change the third sentence of the first paragraph to read:
“Use a tension testing device for unconfined testing, in accordance with ASTM E 488.” |
| 473 | 712.03.L.2 | Change the first sentence in the second paragraph of this subsection to read:
"If using epoxy coated steel reinforcement, epoxy coat mechanical reinforcement splices in accordance with ASTM A 775." |
| 473 | 712.03.L.3 | Delete the existing first sentence in the first paragraph. |
| 473 | 712.03.L.3 | Change the third sentence of the first paragraph to read "Provide two test splices on the largest bar size." |
| 473* | 712.03.L.3 | Change the sentence beginning “Demonstrate to the.... to read:
“Demonstrate to the Engineer that splices have a tensile strength of 125 percent of the bar yield strength and high strength splices have a tensile strength of 150 percent of the bar yield strength.” |
| 488 | 713.02 | Add the following as subsection 713.02.C:
"C. Structural Steel for Retrofitting and Welded Repairs. Structural steel material used for retrofitting and welded repairs of primary |

members as defined in subsection 707.01.B must meet longitudinal Charpy V-Notch impact test requirements."

- 501 715.02 Add the following material reference above the two existing items:
"Sealant for Perimeter of Beam Plates.....713"
- 508 715.03.D.1 Add the following sentence after the second paragraph of the subsection:
"Apply sealant for perimeter of beam plates in accordance with subsection 713.03.F."
- 515 716.03.A Delete the second paragraph of this subsection in its entirety.

Change the last sentence of the last paragraph of this subsection to read:
"Provide a primer dry film thickness for the top flange between 4 mils and 10 mils."
- 519 716.04 Change the second sentence of the first paragraph of this subsection to read:
"The unit price for **Field Repair of Damaged Coating (Structure No.)** includes the costs of making field repairs to the shop applied coating system; prime coat surfaces and exposed surfaces of bolts, nuts, and washers; and repairing stenciling."
- 521 717.04.B This subsection should read "The unit price for **Drain Casting Assembly** includes the cost of providing and installing the downspout and, if necessary, the lower bracket to the drain casting."
- 522 718.02 Change the section number "906" in the third material in the list to read "919."
- 533 718.04 Delete the following pay item from the list:
Temp Casing.....Foot
- 533 718.04.B.2 Delete this subsection in its entirety.
- 533 718.04.B.3 Renummer this subsection as follows:
"2. **Permanent Casing.**"
- 540 802.04 Change "Non reinf" in the last pay item of the list with "Nonreinf".
- 545* 803.04.E Change the second sentence of the second paragraph to read:
"The unit price for **Railing for Steps** includes the cost of providing, fabricating, installing, and grouting the railing."
- 560 807.04 Delete the following pay item from the list:
Guardrail Buffered EndEach
- 560 807.04.B Change the fifth paragraph of this subsection to read:

- “The Engineer will measure **Guardrail Salv** and **Guardrail, Mult, Salv** along the face of the rail (one face for multiple beams), including terminals and end shoes.”
- 567 808.04.C Change the first paragraph of this subsection to read:
"The Department will not pay separately for protective fence required in accordance with subsection 104.07."
- 569 809.04.A Change the first sentence to read:
“The unit price for **Field Office, CI** ___ includes the cost of setup, providing access, grading, maintaining, plowing snow, and utility hook-up charges.”
- 570 809.04.B Delete the existing second and third sentences in the first paragraph and replace them with the following:
“The unit price for **Field Office, Utility Fees** includes the cost of monthly usage fees for electricity, gas, telephone service and charges, fuel for the stove, monthly water and sanitary service.”
- 570 809.04.B Change the existing fourth sentence in the first paragraph to read:
“The Department will reimburse the Contractor for monthly usage fees for electricity, gas, telephone, water and sanitary charges incurred by the Department.”
- 575 810.03.K Change the subsection to read
"K. **Drilled Piles for Cantilever and Truss Foundations.** Construct drilled piles for cantilever and truss foundations in accordance with section 718."
- 578 810.03.N.2 Add the following sentence after the first sentence of the second paragraph on this page:
"Mark each nut and bolt to reference the required rotation."
- 584 810.04 Delete the last pay item in the list:
Truss Fdn Anchor Bolts, Replace.....Each
- 585 810.04.B.1 Change the second paragraph to read:
“The unit prices for **Fdn, Truss Sign Structure Type** __, __ inch Dia, **Cased** and **Fdn, Cantilever Sign Structure Type** __, __ inch Dia, **Cased** include the cost of concrete, slurry, steel reinforcement, permanent casings, anchor bolts, excavation, and disposal of excavated material.”
- 585 810.04.B.2 Change the second sentence of the first paragraph to read:
“The unit prices for **Fdn, Truss Sign Structure Type** __, __ inch Dia, **Uncased** and **Fdn, Cantilever Sign Structure Type** __, __ inch Dia, **Uncased** include the cost of concrete, slurry, steel reinforcement, temporary casings, anchor bolts, excavation, and disposal of excavated material.”

- 596 811.03.G Delete this subsection in its entirety.
- 597* 811.03.H Rename this subsection as follows:
“G. Raised Pavement Marker (RPM) Removal.”
- 597* 811.04 Change "Crosshatching" in the last pay item of the list on this page to "Cross Hatching".
- 598* 811.04 Delete the following pay items from the list:
 Pavt Mrkg, (material), 4 inch, SRSM, (color).....Foot
 Pavt Mrkg, (material), 4 inch, SRSM, 2nd Application, (color).....Foot
- Add the following pay items to the list:
 “Pavt Mrkg, Polyurea, (legend).....Each
 Pavt Mrkg, Polyurea, (symbol).....Each”
- Change the sixth item down the list to read:
 “Pavt Mrkg, Polyurea, __ inch, Cross Hatching, (color)”
- Change the eleventh item down the list to read:
 “Rem Curing Compound, for Longit Mrkg, __ inch.....Foot”
- Change the last item in the list to read:
 “Witness, Log, Layout, \$1000.00”
- 599 811.04.B Delete this subsection in its entirety.
- 599 811.04 Rename the following subsections as follows:
B. Call Back.
C. Pavement Marking Removal.
D. Material Deficiency.”
- 602 812.03.D Change the first sentence to read "Provide and maintain traffic control devices meeting the requirements in the ATSSA Quality Guidelines for Work Zone Traffic Control Devices and Features."
- 603 812.03.D.1 The last sentence on this page should read "Lay the sign behind the guardrail, with the uprights pointing downstream from the traffic, and place the support stands and ballasts close to the guardrail."
- 604 812.03.D.2 The first sentence of the fourth paragraph should read "Do not use burlap or similar material to cover Department or Local Government owned signs."
- 604 812.03.D.5 The fifth sentence of the first paragraph should read "Do not mix drums and cones within a traffic channeling sequence."
- 605 812.03.D.6.b Change the first sentence of the first paragraph to read:
 “The Department will allow the nighttime use of 42-inch channelizing devices, in the tangent area only, on CPM and pavement marking of any

		duration where the use of plastic drums restricts proposed lane widths to less than 11 feet, including shy distance.”
605	812.03.D.7	Add the following sentence after the first sentence of the first paragraph: “Place a shoulder closure taper in advance of the lighted arrows placed on the shoulders.”
607	812.03.D.9	Delete the second paragraph of this subsection and replace with the following: “Link sections together to fully engage the connection between sections. Maintain the barrier with end-attachments engaged and within 2 inches of the alignment shown on the plans.”
608	812.03.D.10.b	Delete the second sentence of the second paragraph of this subsection beginning with "Install sand module attenuators..."
608	812.03.D.10.b	Add the following sentence after the second paragraph of this subsection: “Install impact attenuation devices as shown on the plans, as directed by the Engineer, or both.”
609	812.03.D.10.e	Delete the second paragraph of this subsection.
613	812.03.D.14.a.iii	Change the sentence in this subsection to read "Place an ET Type or SKT Type extruder guardrail ending on both blunt guardrail ends."
615	812.03.F	The second sentence of the second paragraph of this subsection should read: "The Contractor may use a Type R temporary pavement marking cover, per subsection 812.03.D.12 when authorized by the Engineer."
616	812.03.F.2	The last sentence of the first paragraph should read: "If the removal equipment cannot collect all removal debris, operate a self-propelled sweeper capable of continuously vacuuming up the removal debris immediately behind the removal equipment."
617	812.03.G.3	The first sentence of the second paragraph should read: "Sweep the shoulder and remove debris prior to placing traffic on the shoulder and throughout the time the shoulder is used to maintain traffic."
617	812.03.G.4.a	Delete "48 inch by 48 inch" from the first sentence of this subsection.
618*	812.03.G.7	The first sentence of the first paragraph should read: "Clean barrier reflectors, plastic drums, 42 inch channelizing devices, tubular markers, signs, barricades, and attached lights in operation on the project to ensure they meet required luminosity."
619	812.03.G.8	The second sentence of the third paragraph from the end of the subsection should read: "Illuminate traffic regulator stations at night per subsection 812.03.H."
621	812.03.I.6	Delete "48 inch by 48 inch" from the second sentence of this subsection.

- 622* 812.03.J The second paragraph should read "Apply one 2-inch wide horizontal stripe of red and white conspicuity tape along at least 50 percent of each side of, and across the full width of the rear of the vehicle or equipment."
- 622 812.04 Change the second item down the list to read:
"Traf Regulator Control"
- Change the sixth item down the list to read:
"Sign Cover, Type I"
- 626 812.04.I Change the reference "812.04.E" in the first sentence to "812.04.D".
- 628 812.04.M.4 Add the following as the first sentence of this subsection:
"The Engineer will not measure a temporary barrier ending move as **Conc Barrier Ending, Temp, Relocated** if it involves work defined in subsection 812.04.M.3."
- 629 812.04.N.1 Change the reference "811.04.D" in the second paragraph of this subsection to read "811.04.C".
- 630 812.04.S Change the first sentence to read: "The Department will not make additional payments for traffic regulating, signing, arrow boards, and lighting systems for traffic regulator stations operated at night due to a temporary PTS system failure."
- 634 813.03.C.3 Change the reference "903.07.A" in the paragraph of this subsection to read "907.07.B".
- 646 815.04 Change the first, third and fourth pay items in the list to read:
"Site Preparation, Max (dollar) Lump Sum
Watering and Cultivating, First Season, Min (dollar)..... Lump Sum
Watering and Cultivating, Second Season, Min (dollar) Lump Sum"
- 646 815.04.C.1 Change the following pay item reading: "Watering and Cultivating, First Season, Min. (dollar)" to read "Watering and Cultivating, First Season, Min (dollar)" at two locations throughout the subsection.
- 646 815.04.C.1.b Delete this subsection in its entirety.
- 646 815.04.C.1.c Rename this subsection to read:
"b. Removal and disposal of unacceptable plants."
- 646 815.04.C.2 Change the following pay item reading: "Watering and Cultivating, Second Season, Min. (dollar)" to read "Watering and Cultivating, Second Season, Min (dollar)" at three locations throughout the subsection.
- 647 815.04.C.2 Change the last paragraph of this subsection to read:

		<p>“For each unacceptable plant identified, the Engineer will calculate a 50 percent reduction in the unit price for the relevant (Botanical Name) pay item, and will process a negative assessment for each unacceptable plant for that amount.”</p>
650	816.03.B	<p>Delete the first paragraph of this subsection and replace with the following: "Conduct soil tests when called for in the contract or when directed by the Engineer. Provide soils tests results to the Engineer when testing is required. Provide and place fertilizer as indicated below and as indicated in the soils tests, if required."</p>
650	816.03.B.1	<p>Change the sentence to read: "For Class A fertilizer, evenly apply 176 pounds of chemical fertilizer nutrient per acre on a prepared seed bed."</p>
650	816.03.B.2	<p>Change the sentence to read: "For Class B fertilizer, evenly apply 120 pounds of chemical fertilizer nutrient per acre on a prepared seed bed."</p>
650*	816.03.B.3	<p>Change the sentence to read: "For Class C fertilizer, evenly apply 80 pounds of chemical fertilizer nutrient per acre on established turf."</p>
663*	819.01	<p>Delete the first paragraph in the subsection and replace it with the following: “This work consists of providing operating electrical and lighting units; removing, salvaging, or disposing of existing electrical and lighting components; excavating, backfilling, restoring the site in accordance with section 816; and disposing of waste excavated materials. Complete this work in accordance with this section, section 820, and the contract and to the requirements of the NEC, the National Electrical Safety Code, and the MDLARA for those items not identified in the contract.”</p> <p>Change the third sentence of the second paragraph in this subsection to read: “Contact the MDLARA for electrical service inspection and pay the applicable fees.”</p>
671	819.03.F.1	<p>Change the paragraph to read: “Install light standard foundations as shown on the plans and the standard plans, as applicable.”</p>
673	819.03.G.4.b	<p>Change the last sentence of the first paragraph to read: "Tighten the anchor bolts to a snug tight condition as described in the third paragraph of subsection 810.03.N.2 ensuring the lock washer is completely compressed."</p>
673	819.03.G.4.b	<p>Delete the first two sentences of the second paragraph and replace with the following: "Tighten bolts connecting the pole to the frangible base to a snug tight condition. Snug tight is the tightness attained by a few impacts of an</p>

impact wrench, or the full effort of a person using an ordinary spud wrench. The lock washers must be fully compressed."

- 678* 819.04 Delete the last item in the list on this page reading:
"DB Cable, in Conduit, 600 Volt, (number) 1/C# (size) Foot"
- 680 819.04 Change the first paragraph to read:
"Unless otherwise required, the unit prices for the pay items listed in this subsection include the cost of excavation, granular material, backfill, and disposal of waste excavated material. If the contract does not include pay items for restoring the site in kind in accordance with section 816, the Department will consider the cost of restoration included in the pay items listed in this subsection."
- 680 819.04.A Add the following paragraph after the first paragraph of the subsection.
"The unit prices for **Conduit, Rem** include the cost of removing the type, number, and size of conduit shown on the plans."

Change the third paragraph of the subsection to read:
"The unit prices for **Conduit, (type), __ inch** and **Conduit, DB, (number), __ inch** include the cost of installing the type, number, and size of conduit shown on the plans, and installing marking tape."
- 681 819.04.B Change the last paragraph of the subsection to read:
"The unit price for **DB Cable, in Conduit, Rem** includes the cost of removing all cables from the existing conduit measured per lineal foot of conduit."
- 681 819.04.C Change the first paragraph of the subsection to read:
"The unit prices for **Cable, Rem** and **Cable, (type), Rem** include the cost of dead ending, circuit cutting, installing guying, work required to leave circuits operable, and disposing of the removed cables, wire, hardware, and other appurtenances."
- 681 819.04.D Change the first paragraph of the subsection to read:
"The unit price for **Cable, Pole, (type), Disman** includes the cost of dismantling and off-site disposal of the following:"
- 685 820.01.D Change the sentence to read:
"Excavate, backfill, restore the site in kind in accordance with section 816, and dispose of excess or unsuitable material;"
- 688 820.03.C Change the seventh paragraph of this subsection to read:
"Tighten top anchor bolt nuts, snug, in accordance with the first four paragraphs of subsection 810.03.N.2, except beeswax will not be required."
- 696 820.04 Add the following pay items to the list:
"Pedestal, Pushbutton, Alum.....Each
Pedestal, Pushbutton, Rem.....Each"

- 697 820.04.A.2 Change the sentence to read:
 “If the contract does not include pay items for restoring the site in kind in accordance with section 816, the Department will consider the cost of restoration included in the pay items listed in this subsection.”
- 698 820.04.B Delete the second paragraph of this subsection found on this page.
- 698 820.04.C Change "**Fdns**" to read "**Fdn**" in four instances in this subsection.
- 701 820.04.J.3 Change the sentence to read: "Installing wires in the saw slots and to the handholes;"
- 701 820.04.J Add the following as a new subsection:
 “7. A 3/4 inch minimum flexible conduit (non-metallic and rated for underground use) from the pavement to the handhole.”
- 706 821.01.B Change the website address listed after the second paragraph on this page to read:
 “<http://www.ngs.noaa.gov/heightmod/GuidelinesPublications.shtml>”
- 711 822.03.B Change the second paragraph to read:
 “If corrugations are required on concrete shoulders and the method of installation is not shown on the plans or directed by the Engineer, construct corrugations by grinding, or cutting.”
- 720 823.04 Change the pay item seventh from the bottom of the list to read:
 “Water Shutoff, Adj, Temp, Case ___”
- 730 824.03.Q Change the third sentence of the fourth paragraph to read:
 “Ensure placement of monumentation in accordance with section 821.”
- 730 824.03.Q Change the first sentence of the last paragraph to read:
 “The Department will not pay for work dependent on lost or destroyed stakes until the Contractor replaces the stakes.”
- 732 824.04 Change the first sentence of the first paragraph following the list of pay items to read:
 “If the Engineer determines the Contractor will perform staking as extra work, the Department will pay for staking in accordance with section 103.”
- 733 824.04 Change the left column header in Table 824-2 to read:
 “**Percent of Original Contract Amount Earned**”
- 739 902.02 Change the last aggregate testing description to read:
 “Determining Specific Gravity and Absorption of
 Fine Aggregates.....MTM 321”
- 742 902.03.C.1.a Change the sentence to read:

		“Coarse aggregate includes all aggregate particles greater than or retained on the 3/4-inch sieve.”
742	902.03.C.2.a	Change the sentence to read: “Intermediate aggregate includes all aggregate particles passing the 3/4-inch sieve through those retained on the No. 4 sieve.”
742	902.03.C.2.b.iii	Change the sentence to read as follows: “Maximum Loss by Washing per MTM 108 of 3.0 percent”.
744	902.07	Delete the fourth paragraph of the subsection and replace it with the following: “The Engineer will only allow the use of granular material produced from crushed portland cement concrete for embankment and as trench backfill for non-metallic culvert and sewer pipes without associated underdrains. However, granular material produced from crushed portland cement concrete is not permitted as swamp backfill, nor within the top 3 feet below subgrade regardless of the application.
746*	902.11	Change the Item of Work by Section Number column in Table 902-1 for the 6AA row to read: "406, 601, 602, 706, 708, 806". Change the Item of Work by Section Number column in Table 902-1 for the 6A row to read: "206, 401, 402, 406, 601, 602, 603, 706, 806". Change the Item of Work by Section Number column in Table 902-1 for the 34R row to read: "401, 404, 406".
751*	902.11	Replace Table 902-6 with the Table 902-6 below.
751	Table 902-7	Under the Material column in the fourth row change the "FA2" to read "2FA".
751	Table 902-7	Under the Material column in the fifth row change the "FA3" to read "3FA".
752	Table 902-8	Under the Material column in the fourth row change the "FA2" to read "2FA".
752	Table 902-8	Under the Material column in the fifth row change the "FA3" to read "3FA".
761	Table 904-2	Delete the footnote f and any other reference to footnote f from the table.
767	905.03	Change the first sentence of the first paragraph to read: “Deformed bars, must meet the requirements of ASTM A 706, ASTM A 615, or ASTM A 996 (Type R or Type A only) for Grade 60 steel bars, unless otherwise required”.

767*	905.03	Change the first sentence of the second paragraph to read: “Unless otherwise specified, spiral reinforcement must meet the requirements of plain or deformed Grade 40 steel bars of ASTM A 615, ASTM A 996 (Type A), or the requirements of cold-drawn wire of ASTM A 1064”.
767	905.03	Change the first sentence of the third paragraph to read: “Bar reinforcement for prestressed concrete beams must meet the requirements of ASTM A 996 (Type R) for Grade 60 steel bars, except the Engineer will allow bar reinforcement that meets the requirements of ASTM A 615 or ASTM A 996 (Type A) for Grade 40 steel bars for stirrups in prestressed concrete beams”.
768	905.03.C	Change the first sentence in the subsection to read: "Epoxy coated steel reinforcement, if required, must be coated in accordance with ASTM A 775, with the following exceptions and additions."
768	905.03.C.3	Change the first sentence of this subsection to read: "Include written certification that the coated reinforcing bars were cleaned, coated, and tested in accordance with ASTM A 775 with the coating applicator."
768	905.05	Change the first sentence of the first paragraph to read: “Deformed steel bars must meet the requirements of ASTM A 706 or the requirements for Grade 40, Grade 50, or Grade 60 of ASTM A 615 or ASTM A 996 (Type R or Type A only)”.
768	905.06	Delete this subsection in its entirety and replace it with the following: "Deformed wire fabric for prestressed concrete and fabric for concrete pavement reinforcement must meet the requirements of ASTM A 1064 and fabricated as required."
772*	906.07	Change the first paragraph to read: "High-strength bolt fasteners for structural joints must meet the requirements of ASTM F 3125 Grade A 325 Type 1 bolts. High-strength nuts for structural joints must meet the requirements of ASTM A 563 Grade DH or AASHTO M 292 Grade 2H. High-strength washers for structural joints must meet the requirements of ASTM F 436 Type 1 for circular, beveled, clipped circular, and clipped beveled washers." Change the second sentence of the second paragraph of this subsection to read: "Galvanized nuts must be tapped oversize in accordance with ASTM A 563 and meet Supplementary Requirements S1, Lubricant and Rotational Capacity Test for Coated Nuts and S2, Lubricant Dye."
777*	907.03.D.2.a	Change the first sentence of the second paragraph to read: “Angle sections must be nominal 2½ inch by 2½ inch by ¼ inch.”
777*	907.03.D.2.b	Change the first sentence of the first paragraph to read:

- “Angle section braces must be nominal 1¾ inch by 1¾ inch by ¼ inch or nominal 2 inch by 2 inch 3/16 inch.”
- 782 908.04 Change the first sentence of the first paragraph of this subsection to read:
"Steel castings for steel construction must meet the requirements of ASTM A 148 for Grade 60/90 carbon steel castings, as shown on the plans, unless the Engineer approves an alternate in writing."
- 783* 908.09.A Change the title of this subsection and the first sentence to read
"A. **Base Plates, Angle, and Non-Tubular Post Elements.** Galvanized base plates, angle, rail splice elements, and non-tubular post elements must meet the requirements of ASTM A 36 and ASTM A 123".
- 783* 908.09.B Change the title of this subsection and the first sentence to read
"B. **Rail Elements and Tubular Post Elements.** Rail elements and tubular post elements must meet the requirements of ASTM A 500, for Grade B and subsection 908.09.B and be galvanized in accordance with ASTM A 123".
- 784* 908.09.C Change this subsection to read:
"C. **Hardware.** Railing anchor studs must meet the requirements of ASTM A 449 Type 1. Heavy hex nuts must meet the requirements of ASTM A 563. Bolts, used as rail fasteners, must meet the requirements of ASTM F 3125 Grade A 325, Type 1. Where called for, round head bolts must meet the requirements of ASTM A 449 Type 1. The material for the railing hand hole screws must meet the requirements of ASTM A 276, Type 304. All nuts must meet the requirements of ASTM A 563 Grade DH or AASHTO M 292 Grade 2H. All flat washers must meet the requirements of ASTM F 436. Lock washers must be steel, regular, helical spring washers meeting the requirements of ANSI B18.21.1 - 1972. Bolts, nuts, washers and other hardware must be hot-dip galvanized in accordance with AASHTO M 232. Galvanized nuts must be tapped oversize in accordance with ASTM A 563, and meet Supplementary Requirements S1, Lubricant and Rotational Capacity Test for Coated Nuts, and S2, Lubricant Dye."
- 785* 908.11.B Change the second paragraph to read:
"Bolts, nuts, and round washers for guardrail, other than at bridge barrier railings, must meet the requirements of ASTM A 307 (Grade A), ASTM A 563 (Grade A with Supplementary Requirements S1 of ASTM A 563), and ASTM F 436, respectively."

Change the third paragraph to read:
"Washers, other than round washers, for guardrail must meet the requirements for circular washers in ASTM F 436 except that the dimensions must be as shown on the plans."

Change the fifth paragraph to read:

		"Bolts, nuts, and washers for connections at bridge barrier railings must conform to ASTM F 3125 Grade A 325 Type 1 galvanized high-strength structural bolts with suitable nuts and hardened washers."
787	908.14.B	<p>Add the following sentence to the end of the third paragraph of this subsection: "Exposed threaded ends of anchor bolts must be galvanized a minimum of 20 inches."</p> <p>Change the sixth paragraph in this subsection to read: "Provide washers meeting the requirements of ASTM F 436 for circular washers."</p>
787	908.14.B	Change the second sentence of the fourth paragraph to read "After coating, the maximum limit of pitch and major diameter for bolts with a diameter no greater than 1 inch may exceed the Class 2A limit by no greater than 0.021 inch, and by no greater than 0.031 inch for bolts greater than 1 inch in diameter".
787*	908.14.C	Change the first paragraph to read "Provide either four or six high strength anchor bolts per the contract plans, meeting the mechanical requirements of ASTM F 1554, for Grade 105, with each standard. Anchor bolts for traffic signal strain poles must meet the requirements of subsection 908.14.B with the following exceptions and additions:"
789	909.03	<p>Change the second sentence of the second paragraph to read: "As an alternative to the AASHTO M 36 requirements for metal pipe, the Contractor may use gasket material meeting the low temperature flexibility and elevated temperature flow test requirements of ASTM C 990, excluding the requirements for softening point, flashpoint and fire point."</p>
793	909.06	<p>Change the first sentence of the second paragraph of this subsection to read: "Provide Corrugated Polyvinyl Chloride Pipe (CPV) and required fittings meeting the requirements of AASHTO M 304."</p>
793*	909.05.D	Change the second sentence of the paragraph to read "Provide a continuous welded joint to create a watertight casing that is capable of withstanding handling and installation stresses. Perform field welding by the SMAW process using E7018 electrodes."
794*	909.08.A	<p>Change the first sentence to read: "Provide bridge deck downspouts of PE pipe meeting the requirements of ASTM F 714, PE 4710, DR 26."</p>
804	Table 909-9	In the note area at the bottom of the table change the designation of the second note from "c." to "b."
811	910.04	Add the following sentence to the end of this subsection:

		"Fabricate silt fence according to subsection 916.02."
814	Table 911-1	In the 4 th row of the 5 rows in the table change the Property listed as "Total Organic Content (TOC)" to read "Total Organic Carbon (TOC)".
829*	912.08.K	Replace Table 912-10 with the Table 912-10 below.
833*	913.03.B	Change the first sentence of the first paragraph to read: "Clay brick, to construct manholes, catch basins, and similar structures, must meet the requirements of ASTM C 32, for Grade MS."
837*	914.04	Add the following as subsection 914.04.C: "C. Lubricant-Adhesive for Neoprene Joint Seals. The lubricant-adhesive must be a single-component moisture-curing polyurethane and aromatic hydrocarbon solvent mixture meeting ASTM D 2835, Type I. Ship in containers plainly marked with the lot or batch number of the material and date of manufacture. Store at temperatures between 58 and 80°F. Do not exceed 12 months shelf-life prior to use."
840	914.08	Change the first sentence of the second paragraph to read: "Straight tie bars for end-of-pour joints must consist of bars of the diameter and length shown on the plans meeting the requirements of ASTM A 615, ASTM A 706, or ASTM A 996 (Type R or Type A only)".
840*	914.09.A	Change the first sentence of the first paragraph to read: "Straight tie bars for longitudinal pavement joints must consist of bars of the diameter and length shown on the plans meeting the requirements of ASTM A 615, ASTM A 706, or ASTM A 996 (Type R or Type A only)".
840	914.09.B	Change the first sentence of the first paragraph to read: "Bent tie bars for bulkhead joints must consist of bars of the diameter and length shown on the plans."
841	914.12	In the first sentence of this subsection change "AASHTO Division II" to read "AASHTO LRFD Bridge Construction Specifications".
841*	914.13	In the first sentence of this subsection change "ASTM D 1248, for Type III, Class B" to read "ASTM D 4976, Group 2, Class 4, Grade 4".
844	916.01.A	Change the first sentence to read: "Cobblestone must consist of rounded or semi-rounded rock fragments with an average dimension from 3 inches to 10 inches."
845	916.01.D.1	Change the second sentence to read: "Checkdams for ditch grades 2 percent or greater must be constructed using cobblestone or broken concrete ranging from 3 inches to 10 inches in size."
851*	917.10.B.1	Delete the paragraph and replace it with the following: "1. Class A. Provide and apply Class A chemical nutrient fertilizer either according to MSU Soil Testing Lab Recommendations for

Phosphorus Applications to Turfgrass, except the maximum single application rate of nutrient will be 48 pounds per acre, when soil tests are required or as indicated in subsections 917.10.B.1.a and 917.10.B.1.b.”

- 851 917.10.B.1 Add the MSU Soil Testing Lab Recommendations for Phosphorus Applications to Turfgrass, found below, after the first paragraph of this subsection.
- 853 917.15.B.1 Change the second sentence of the subsection to read:
“The net must meet the requirements of subsection 917.15.D and be capable of reinforcing the blanket to prevent damage during shipping, handling, and installation.”
- 857 918.01 Add the following two paragraphs following the first paragraph of this subsection:
“Wall thickness and outside diameter dimensions must conform to ASTM D 1785 for smooth-wall schedule 40 and 80 PVC conduit material. The Department will allow no more than 3 percent deviation from the minimum wall thickness specified.

Wall thickness range must be within 12 percent in accordance with ASTM D 3035 for smooth-wall coilable schedule 40 and 80 PE conduit.”
- 858 918.01.E Delete the first three sentences of the second paragraph shown on page 858.
- 863 918.06.F.1 Delete the third paragraph in this subsection in its entirety and replace it with the following:
"Provide smooth or deformed welded wire fabric in accordance with ASTM A 1064."
- 864 918.07.C Change the first sentence of the first paragraph to read:
“Provide anchor bolts, nuts, and washers meeting the requirements of subsection 908.14.A and subsection 908.14.B.”
- 864 918.07.C Delete the second sentence of the second paragraph.
- 864 918.07.C Change the third sentence to read:
“Provide anchor bolts threaded 4 inches beyond the anchor bolt projection shown on the plans.”
- 867 918.08.C Change the last sentence of the first paragraph on this page to read:
“Galvanize bolts, nuts, washers, and lock washers as specified in subsection 908.14.B.”
- 867 918.08.C Change the last sentence of the subsection to read:
“Provide each frangible base with manufacturer access covers as shown on the plans.”

867*	918.08.D	Delete this subsection in its entirety and replace with the following: "Provide galvanized anchor bolts, studs, nuts, couplings, and washers in accordance with subsection 908.14."
879	918.10.J	Change the third sentence of the second paragraph of this subsection to read: "Provide anchor bolts and associated nuts, washers, and hardware meeting the requirements of subsection 908.14."
887	919.06	Change the second paragraph to read: "Shims must be fabricated from brass shim stock or brass strip meeting the requirements of ASTM B 36, for copper alloy UNS No. C26000, half-hard rolled temper, or fabricated from galvanized sheeting meeting the requirements of ASTM A 653, for Coating Designation G 90."
887	919.07.C	Change the sentence to read: "Galvanized high-strength steel bolts, nuts, and washers for connecting arm connection flanges must meet the requirements of subsection 906.07."
903	921.03.D	Delete the last three sentences of the first paragraph of this subsection.
914	921.05.D	Change the first sentence of this subsection to read: "Provide anchor bolts meeting the requirements of subsection 908.14.C, including elongation and reduction of area requirements."
916	921.07	Change the first sentence of the first paragraph to read: "Provide LED case signs internally illuminated by LEDs and changeable message case signs internally illuminated with LED light sources."
936	922.04.B	In the first sentence of the first paragraph change the "R-52" to "R-126".
936	922.04.B	Add the following to the end of the first paragraph: "Hardware used to connect the end section to the barrier must meet the requirements of NCHRP 350 or MASH (Test Level 3 or higher)."
936	922.04.B	In the first sentence of the second paragraph delete "R-52".
936	922.04.B	Change the fourth paragraph of this subsection to read as follows: For all endings requiring impact attenuators provide a NCHRP-350 Test Level 3 or MASH Test Level 3 approved impact attenuation system, unless otherwise approved by the Engineer.
953*	Pay Item Index	Delete the following pay item reading: "DB Cable, in Conduit, 600 Volt, (number) 1/C# (size)678 819"
957	Pay Item Index	Delete the following pay item from the list: Guardrail Buffered End560 807
960	Pay Item Index	Change the following pay item to read:

		"Mobilization, Max (dollar)	107	150"
961	Pay item Index	Delete the following pay items from the list: Pavt Mrkg, (material), 4 inch, SRSM, (color).....	598.....	811
		Pavt Mrkg, (material), 4 inch, SRSM, 2 nd Application, (color).....	598.....	811
961	Pay Item Index	Change the following pay items in the list to read: Pavt Mrkg, Ovly Cold Plastic, 12 inch, Cross Hatching, (color) Pavt Mrkg, Polyurea, __ inch, Cross Hatching, (color)		
		Add the following pay items to the list: "Pavt Mrkg, Polyurea, (legend).....	598.....	811
		Pavt Mrkg, Polyurea, (symbol).....	598.....	811
		Pedestal, Pushbutton, Alum.....	696.....	820
		Pedestal, Pushbutton, Rem.....	696.....	820"
962	Pay Item Index	Change the following pay items in the list to read: "Pile Driving Equipment, Furn (Structure No.) Pile, Galv (Structure No.)"		
963	Pay Item Index	Change the following pay item to read: "Rem Curing Compound, for Longit Mrkg, __ inch	598	811"
964	Pay Item Index	Change the following pay item to read: "Sewer, CI __, __ inch, Jacked in Place	200	402"
		"Sign Cover, Type I	622	812"
965*	Pay Item Index	Change the following pay item in the list to read: "Steel Casing Pipe, __ inch, Tr Det __ Site Preparation, Max (dollar)	646	815"
966	Pay Item Index	Delete the following pay item form the list; Temp Casing.....	533.....	718
967*	Pay Item Index	Delete the following pay item from the list; Truss Fdn Anchor Bolts, Replace.....	584.....	810
967	Pay Item Index	Change the following pay item in the list to read: "Traf Regulator Control"		
968*	Pay item Index	Change the following pay item in the list to read: "Water Shutoff, Adj, Temp, Case __ Watering and Cultivating, First Season, Min (dollar).....	646	815
		Watering and Cultivating, Second Season, Min (dollar)	646	815"
969	Pay item Index	Change the following pay item in the list to read: "Witness, Log, Layout, \$1000.00"		

993 General Index Change “Shop Plans (see Plans and Working Drawings)” to read “Shop Drawings (see Plans and Working Drawings)”.

**Table 701-1
Concrete Structure Mixtures**

Concrete Grade (e,h)	Section Number Reference (i)	Cement Content per cyd (b,c)		Type A, D or no Admixture	Slump (inches)			Minimum Strength of Concrete (f)					
		lb	sack		Type MR, F, or G Admixtures (g)			Flexural (psi)			Compressive (psi)		
					Before Admixture	After Admixture (Type MR)	After Admixture (Type F or G)	7 Day	14 Day	28 Day (Class Design Strength)	7 Day	14 Day	28 Day (Class Design Strength)
D (a)	706, 711, 712	658 (d)	7.0	0 - 3	0 - 3	0 - 6	0 - 7	625	700	725	3,200	4,000	4,500
S1	705	611	6.5	3 - 5	0 - 3	3 - 6	3 - 7	600	650	700	3,000	3,500	4,000
T	705, 706	611	6.5	3 - 7	0 - 4	3 - 7	3 - 8	550	600	650	2,600	3,000	3,500
S2 (a)	401, 705, 706, 712, 713, 801, 802, 803, 810	564	6.0	0 - 3	0 - 3	0 - 6	0 - 7	550	600	650	2,600	3,000	3,500
		526 (d)	5.6										
S3	402, 403, 803, 804, 806	517	5.5	0 - 3	0 - 3	0 - 6	0 - 7	500	550	600	2,200	2,600	3,000
		489 (d)	5.2										

- a. Unless otherwise required, use Coarse Aggregate 6AA or 17A for exposed structural concrete in bridges, retaining walls, and pump stations.
- b. Do not place concrete mixtures containing supplemental cementitious materials unless the local average minimum temperature for the next 10 consecutive days is forecast to be above 40 °F. Adjustments to the time required for opening to construction or vehicular traffic may be necessary. Cold weather protection may be required, as described in the quality control plan. The restriction does not apply to Grade S1 concrete in foundation piling below ground level or Grade T concrete in tremie construction.
- c. Type III cement is not permitted
- d. Use admixture quantities specified by the Qualified Products Lists to reduce mixing water. Admixture use is required for Grade D, Grade S2, and Grade S3, concrete with a reduced cement content. Use a water-reducing retarding admixture at the required dosage for Grade D concrete to provide the setting retardation required. When the maximum air temperature is not forecast to exceed 60 °F for the day, the Contractor may use a water-reducing admixture or a water-reducing retarding admixture. Ensure Grade D concrete in concrete diaphragms contains a water-reducing admixture, or a water-reducing retarding admixture. For night casting, the Contractor may use a water-reducing admixture in lieu of water-reducing retarding admixture, provided that the concrete can be placed and finished prior to initial set.
- e. The mix design basis for bulk volume (dry, loose) of coarse aggregate per unit volume of concrete is 68% for Grade S1, and 70% for Grade D, Grade S2, Grade T, and Grade S3.
- f. The Contractor may use flexural strength to determine form removal. Use compressive strength for acceptance in other situations.
- g. MR = Mid-range.
- h. The Engineer will allow the use of an optimized aggregate gradation as specified in section 604.
- i. Section Number Reference:
- | | | | | | |
|-----|----------------------------------|-----|------------------------------------|-----|--|
| 401 | Culverts | 711 | Bridge Railings | 803 | Concrete Sidewalk, Sidewalk Ramps, and Steps |
| 402 | Storm Sewers | 712 | Bridge Rehabilitation-Concrete | 804 | Concrete Barriers and Glare Screens |
| 403 | Drainage Structures | 713 | Bridge Rehabilitation-Steel | 806 | Bicycle Paths |
| 705 | Foundation Piling | 801 | Concrete Driveways | 810 | Permanent Traffic Signs and Supports |
| 706 | Structural Concrete Construction | 802 | Concrete Curb, Gutter and Dividers | | |

**Table 902-6
Superpave Final Aggregate Blend Physical Requirements**

Est. Traffic (million ESAL)	Mix Type	Percent Crushed Minimum Criteria		Fine Aggregate Angularity Minimum Criteria		% Sand Equivalent Minimum Criteria		Los Angeles Abrasion % Loss Maximum Criteria		% Soft Particles Maximum Criteria (b)		% Flat and Elongated Particles Maximum Criteria (c)	
		Top & Leveling Courses	Base Course	Top & Leveling Courses	Base Course	Top & Leveling Courses	Base Course	Top & Leveling Courses	Base Course	Top & Leveling Courses	Base Course	Top & Leveling Courses	Base Course
< 0.3	LVSP	55/—	—	—	—	40	40	45	45	10	10	—	—
< 0.3	E03	55/—	—	—	—	40	40	45	45	10	10	—	—
≥0.3 - <1.0	E1	65/—	—	40	—	40	40	40	45	10	10	—	—
≥1.0 - <3	E3	75/—	50/—	40(a)	40(a)	40	40	35	40	5	5	10	10
≥3 - <10	E10	85/80	60/—	45	40	45	45	35	40	5	5	10	10
≥10 - <30	E30	95/90	80/75	45	40	45	45	35	35	3	4.5	10	10
≥30 - <100	E50	100/10 0	95/90	45	45	50	50	35	35	3	4.5	10	10

(a) For an E3 mixture type that enters the restricted zone as defined in Table 902-5, the minimum is 43. If these criteria are satisfied, acceptance criteria and associated incentive/disincentive or pay adjustment tied to this gradation restricted zone requirement included in contract, do not apply. Otherwise, final gradation blend must be outside of the restricted zone.

(b) Soft particles maximum is the sum of the shale, siltstone, ochre, coal, clay-ironstone and particles that are structurally weak or are non-durable in service.

(c) Maximum by weight with a 1 to 5 aspect ratio.

Note: "85/80" denotes that 85 percent of the coarse aggregate has one fractured face and 80 percent has at least two fractured faces.

Table 912-10 Minimum Retention Requirements				
Preservative	Minimum Retention, (pcf)			AWPA Standard
	Guardrail Posts	Sign Posts	Blocks	
Pentachlorophenol	0.60	0.50	0.40	A6
CCA, ACZA	0.60	0.50	0.40	A11
ACQ (a)	0.60	Not Allowed	0.40	A11
CA-B (a)	0.31	Not Allowed	0.21	A11
CA-A (a)	0.31	Not Allowed	0.15	A11
Other Waterborne preservatives	AWPA Commodity Specification A, Table 3.0, Use Category 4B	Not Allowed	AWPA Commodity Specification A, Table 3.0, Use Category 4A	A11
a. Non-Metallic washers or spacers are required for timber and lumber treated with ACQ or CA placed in direct contact with aluminum. Do not use with sign posts.				

MSU Soil Testing Lab Recommendations for Phosphorus Applications to Turfgrass
3/8/2012

		Sand based rootzone establishment	Golf greens and tees est. or mature; Kentucky bluegrass or perennial ryegrass athletic fields est. or mature; sand based rootzone mature	Lawns, golf course fairways; establishment or mature	Establishment without soil test
Bray P1, Mehlich 3 Soil Test Value (ppm): pH<7.4	Olsen Soil Test Value (ppm) pH>7.4	Recommendation (lbs. P ₂ O ₅ /1000 ft. ²)	Recommendation (lbs. P ₂ O ₅ /1000 ft. ²)	Recommendation (lbs. P ₂ O ₅ /1000 ft. ²)	Recommendation (lbs. P ₂ O ₅ /1000 ft. ²)
0	0	4.4	3.4	2.5	2.5 lbs. year (Maximum single application of 1.5 lbs.)
2	1.3	4.1	3.1	2.2	
4	2.7	3.9	2.7	1.9	
6	4	3.6	2.4	1.6	
8	5.3	3.4	2.0	1.3	
10	6.7	3.1	1.7	1.0	
12	8	2.8	1.4	0.7	
14	9.3	2.6	1.0	0.4	
16	10.7	2.3	0.7	0.1	
18	12	2.1	0.3	0.0	
20	13.3	1.8	0.0		
22	14.7	1.5			
24	16	1.3			
26	17.3	1.0			
28	18.7	0.8			
30	20	0.5			
32	21.3	0.2			
34	22.7	0.0			

Web resources: www.turf.msu.edu or www.bephosphorusmart.msu.edu

General Decision Number: MI170001 02/17/2017 MI1

Superseded General Decision Number: MI20160001

State: Michigan

Construction Types: Highway (Highway, Airport & Bridge xxxxx and Sewer/Incid. to Hwy.)

Counties: Michigan Statewide.

Note: Under Executive Order (EO) 13658, an hourly minimum wage of \$10.20 for calendar year 2017 applies to all contracts subject to the Davis-Bacon Act for which the contract is awarded (and any solicitation was issued) on or after January 1, 2015. If this contract is covered by the EO, the contractor must pay all workers in any classification listed on this wage determination at least \$10.20 (or the applicable wage rate listed on this wage determination, if it is higher) for all hours spent performing on the contract in calendar year 2017. The EO minimum wage rate will be adjusted annually. Additional information on contractor requirements and worker protections under the EO is available at www.dol.gov/whd/govcontracts.

Modification Number	Publication Date
0	01/06/2017
1	02/03/2017
2	02/17/2017

CARP0004-004 06/01/2016

REMAINDER OF STATE

	Rates	Fringes
CARPENTER (Piledriver).....	\$ 26.33	19.18

CARP0004-005 06/01/2016

LIVINGSTON (Townships of Brighton, Deerfield, Genoa, Hartland, Oceola & Tyrone), MACOMB, MONROE, OAKLAND, SANILAC, ST. CLAIR AND WAYNE COUNTIES

	Rates	Fringes
CARPENTER (Piledriver).....	\$ 29.47	25.94

* ELEC0017-005 06/01/2016

STATEWIDE

	Rates	Fringes
Line Construction		
Groundman/Driver.....	\$ 27.63	13.48
Journeyman Signal Tech, Communications Tech, Tower		
Tech & Fiber Optic Splicers..	\$ 37.60	16.27
Journeyman Specialist.....	\$ 43.24	17.84
Operator A.....	\$ 31.81	14.63
Operator B.....	\$ 29.72	14.07

Classifications

Journeyman Specialist: Refers to a crew of only one person working alone.

Operator A: Shall be proficient in operating all power equipment including: Backhoe, Excavator, Directional Bore and Boom/Digger truck.

Operator B: Shall be proficient in operating any 2 of the above mentioned pieces of equipment listed under Operator A.

 ENGI0324-003 06/01/2016

ALCONA, ALPENA, ARENAC, BAY, CHEBOYGAN, CLARE, CLINTON, CRAWFORD, GENESEE, GLADWIN, GRATIOT, HURON, INGHAM, IOSCO, ISABELLA, JACKSON, LAPEER, LENAWEE, LIVINGSTON, MACOMB, MIDLAND, MONROE, MONTMORENCY, OAKLAND, OGEMAW, OSCODA, OTSEGO, PRESQUE ISLE, ROSCOMMON, SAGINAW, ST. CLAIR, SANILAC, SHIAWASSEE, TUSCOLA, WASHTENAW AND WAYNE COUNTIES:

	Rates	Fringes
OPERATOR: Power Equipment (Steel Erection)		
GROUP 1.....	\$ 44.07	22.55
GROUP 2.....	\$ 45.07	22.55
GROUP 3.....	\$ 42.57	22.55
GROUP 4.....	\$ 43.57	22.55
GROUP 5.....	\$ 41.07	22.55
GROUP 6.....	\$ 42.07	22.55
GROUP 7.....	\$ 40.80	22.55
GROUP 8.....	\$ 41.80	22.55
GROUP 9.....	\$ 40.35	22.55
GROUP 10.....	\$ 41.35	22.55
GROUP 11.....	\$ 39.62	22.55
GROUP 12.....	\$ 40.62	22.55
GROUP 13.....	\$ 39.26	22.55
GROUP 14.....	\$ 40.26	22.55
GROUP 15.....	\$ 38.62	22.55
GROUP 16.....	\$ 36.92	22.55
GROUP 17.....	\$ 31.81	22.55
GROUP 18.....	\$ 30.40	22.55

FOOTNOTE:

Paid Holidays: New Year's Day, Memorial Day, Fourth of July, Labor Day, Thanksgiving Day and Christmas Day.

POWER EQUIPMENT OPERATOR CLASSIFICATIONS

GROUP 1: Engineer when operating combination of boom and jib 400' or longer

GROUP 2: Engineer when operating combination of boom and jib 400' or longer on a crane that requires an oiler

GROUP 3: Engineer when operating combination of boom and jib 300' or longer

GROUP 4: Engineer when operating combination of boom and jib 300' or longer on a crane that requires an oiler

GROUP 5: Engineer when operating combination of boom and jib 220' or longer

GROUP 6: Engineer when operating combination of boom and jib 220' or longer on a crane that requires an oiler

GROUP 7: Engineer when operating combination of boom and jib 140' or longer

GROUP 8: Engineer when operating combination of boom and jib 140' or longer on a crane that requires an oiler

GROUP 9: Tower crane & derrick operator (where operator's work station is 50 ft. or more above first sub-level)

GROUP 10: Tower crane & derrick operator (where operator's work station is 50 ft. or more above first sub-level) on a crane that requires an oiler

GROUP 11: Engineer when operating combination of boom and jib 120' or longer

GROUP 12: Engineer when operating combination of boom and jib 120' or longer on a crane that requires an oiler

GROUP 13: Crane operator; job mechanic and 3 drum hoist and excavator

GROUP 14: Crane operator on a crane that requires an oiler

GROUP 15: Hoisting operator; 2 drum hoist and rubber tired backhoe

GROUP 16: Forklift and 1 drum hoist

GROUP 17: Compressor or welder operator

GROUP 18: Oiler

ENGI0324-004 06/01/2016

AREA 1: ALLEGAN, BARRY, BERRIEN, BRANCH, CALHOUN, CASS, EATON, HILLSDALE, IONIA, KALAMAZOO, KENT, LAKE, MANISTEE, MASON, MECOSTA, MONTCALM, MUSKEGON, NEWAYGO, OCEANA, OSCEOLA, OTTAWA, ST. JOSEPH, VAN BUREN

AREA 2: ANTRIM, BENZIE, CHARLEVOIX, EMMET, GRAND TRAVERSE, KALKASKA, LEELANAU, MISSAUKEE AND WEXFORD COUNTIES:

	Rates	Fringes
OPERATOR: Power Equipment (Steel Erection)		
AREA 1		
GROUP 1.....	\$ 44.07	22.55
GROUP 2.....	\$ 40.80	22.55
GROUP 3.....	\$ 39.62	22.55
GROUP 4.....	\$ 36.92	22.55
GROUP 5.....	\$ 31.81	22.55
GROUP 6.....	\$ 30.40	22.55
AREA 2		
GROUP 1.....	\$ 44.07	22.55
GROUP 2.....	\$ 40.80	22.55
GROUP 3.....	\$ 39.26	22.55
GROUP 4.....	\$ 36.92	22.55
GROUP 5.....	\$ 31.81	22.55

GROUP 6.....\$ 30.40

22.55

FOOTNOTES:

Crane operator with main boom and jib 300' or longer: \$1.50 additional to the group 1 rate. Crane operator with main boom and jib 400' or longer: \$3.00 additional to the group 1 rate.

PAID HOLIDAYS: New Year's Day, Memorial Day, Fourth of July, Labor Day, Thanksgiving Day and Christmas Day.

POWER EQUIPMENT OPERATOR CLASSIFICATIONS:

GROUP 1: Crane Operator with main boom & jib 400', 300', or 220' or longer.

GROUP 2: Crane Operator with main boom & jib 140' or longer, Tower Crane; Gantry Crane; Whirley Derrick.

GROUP 3: Regular Equipment Operator, Crane, Dozer, Loader, Hoist, Straddle Wagon, Mechanic, Grader and Hydro Excavator.

GROUP 4: Air Tugger (single drum), Material Hoist Pump 6" or over, Elevators, Brokk Concrete Breaker.

GROUP 5: Air Compressor, Welder, Generators, Conveyors

GROUP 6: Oiler and fire tender

ENGI0324-005 06/01/2016

AREA 1: GENESEE, LAPEER, LIVINGSTON, MACOMB, MONROE, OAKLAND, ST. CLAIR, WASHTENAW AND WAYNE COUNTIES

AREA 2: ALCONA, ALLEGAN, ALGER, ALPENA, ANTRIM, ARENAC, BARAGA, BARRY, BAY, BENZIE, BERRIEN, BRANCH, CALHOUN, CASS, CHARLEVOIX, CHEBOYGAN, CHIPPEWA, CLARE, CLINTON, CRAWFORD, DELTA, DICKINSON, EATON, EMMET, GLADWIN, GOGEBIC, GRAND TRAVERSE, GRATIOT, HILLSDALE, HOUGHTON, HURON, INGHAM, IONIA, IOSCO, IRON, ISABELLA, JACKSON, KALAMAZOO, KALKASKA, KENT, KWEENAW, LAKE, LEELANAU, LENAWEE, LUCE, MACKINAC, MANISTEE, MARQUETTE, MASON, MECOSTA, MENOMINEE, MIDLAND, MISSAUKEE, MONTCALM, MONTMORENCY, MUSKEGON, NEWAYGO, OCEANA, OGEMAW, ONTONAGON, OSCEOLA, OSCODA, OTSEGO, OTTAWA, PRESQUE ISLE, ROSCOMMON, SAGINAW, SANILAC, SCHOOLCRAFT, SHIAWASSEE, ST. JOSEPH, TUSCOLA, VAN BUREN AND WEXFORD COUNTIES

Rates

Fringes

OPERATOR: Power Equipment
(Underground construction
(including sewer))

AREA 1:

GROUP 1.....	\$ 31.58	22.85
GROUP 2.....	\$ 26.85	22.85
GROUP 3.....	\$ 26.12	22.85
GROUP 4.....	\$ 25.55	22.85

AREA 2:

GROUP 1.....	\$ 29.87	22.85
GROUP 2.....	\$ 24.98	22.85
GROUP 3.....	\$ 24.48	22.85
GROUP 4.....	\$ 24.20	22.85

POWER EQUIPMENT OPERATOR CLASSIFICATIONS

GROUP 1: Backfiller tamper; Backhoe; Batch plant operator (concrete); Clamshell; Concrete paver (2 drums or larger); Conveyor loader (Euclid type); Crane (crawler, truck type or pile driving); Dozer; Dragline; Elevating grader; Endloader; Gradall (and similar type machine); Grader; Mechanic; Power shovel; Roller (asphalt); Scraper (self-propelled or tractor drawn); Side boom tractor (type D-4 or equivalent and larger); Slip form paver; Slope paver; Trencher (over 8 ft. digging capacity); Well drilling rig; Concrete pump with boom operator; Hydro Excavator

GROUP 2: Boom truck (power swing type boom); Crusher; Hoist; Pump (1 or more - 6-in. discharge or larger - gas or diesel- powered or powered by generator of 300 amperes or more - inclusive of generator); Side boom tractor (smaller than type D-4 or equivalent); Tractor (pneu-tired, other than backhoe or front end loader); Trencher (8-ft. digging capacity and smaller); Vac Truck

GROUP 3: Air compressors (600 cfm or larger); Air compressors (2 or more-less than 600 cfm); Boom truck (non-swinging, non- powered type boom); Concrete breaker (self-propelled or truck mounted - includes compressor); Concrete paver (1 drum-1/2 yd. or larger); Elevator (other than passenger); Maintenance person; Pump (2 or more-4-in. up to 6-in. discharge-gas or diesel powered - excluding submersible pumps); Pumpcrete machine (and similar equipment); Wagon drill (multiple); Welding machine or generator (2 or more-300 amp. or larger - gas or diesel powered)

GROUP 4: Boiler; Concrete saw (40 hp or over); Curing machine (self-propelled); Farm tractor (with attachment); Finishing machine (concrete); Fire person; Hydraulic pipe pushing machine; Mulching equipment; Oiler; Pumps (2 or more up to 4-in. discharge, if used 3 hours or more a day, gas or diesel powered - excluding submersible pumps); Roller (other than asphalt); Stump remover; Trencher (service); Vibrating compaction equipment, self-propelled (6 ft. wide or over); End dump operator; Sweeper (Wayne type); Water wagon and Extend-a boom forklift

ENGI0324-006 06/01/2016

AREA 1: GENESEE, MACOMB, MONROE, OAKLAND, WASHTENAW AND WAYNE COUNTIES

AREA 2: ALCONA, ALGER, ALLEGAN, ALPENA, ANTRIM, ARENAC, BARAGA, BARRY, BAY, BENZIE, BERRIEN, BRANCH, CALHOUN, CASS, CHARLEVOIX, CHEBOYGAN, CHIPPEWA, CLARE, CLINTON, CRAWFORD, DELTA, DICKINSON, EATON, EMMET, GLADWIN, GOGEBIC, GRAND TRAVERSE, GRATIOT, HILLSDALE, HOUGHTON, HURON, INGHAM, IONIA, IOSCO, IRON, ISABELLA, JACKSON, KALAMAZOO, KALKASKA, KENT, KEWEENAW, LAKE, LAPEER, LEELANAU, LENAWEE, LIVINGSTON, LUCE, MACKINAC, MANISTEE, MARQUETTE, MASON, MECOSTA, MENOMINEE, MIDLAND, MISSAUKEE, MONTCALM, MONTMORENCY, MUSKEGON, NEWAYGO, OCEANA, OGEMAW, ONTONAGON, OSCEOLA, OSCODA, OTSEGO, OTTAWA, PRESQUE ISLE, ROSCOMMON, SAGINAW, ST. CLARE, ST. JOSEPH, SANILAC, SCHOOLCRAFT, SHIAWASSEE, TUSCOLA, VAN BUREN AND WEXFORD COUNTIES

Rates

Fringes

Power equipment operators:
(AIRPORT, BRIDGE & HIGHWAY

CONSTRUCTION)

AREA 1

GROUP 1.....	\$ 31.66	22.85
GROUP 2.....	\$ 24.93	22.85
GROUP 3.....	\$ 26.23	22.85
GROUP 4.....	\$ 24.37	22.85
GROUP 5.....	\$ 24.20	22.85

AREA 2

GROUP 1.....	\$ 31.66	22.85
GROUP 2.....	\$ 24.78	22.85
GROUP 3.....	\$ 26.08	22.85
GROUP 4.....	\$ 24.22	22.85
GROUP 5.....	\$ 23.90	22.85

POWER EQUIPMENT OPERATOR CLASSIFICATIONS

GROUP 1: Asphalt plant operator; Crane operator (does not include work on bridge construction projects when the crane operator is erecting structural components); Dragline operator; Shovel operator; Locomotive operator; Paver operator (5 bags or more); Elevating grader operator; Pile driving operator; Roller operator (asphalt); Blade grader operator; Trenching machine operator (ladder or wheel type); Auto-grader; Slip form paver; Self-propelled or tractor-drawn scraper; Conveyor loader operator (Euclid type); Endloader operator (1 yd. capacity and over); Bulldozer; Hoisting engineer; Tractor operator; Finishing machine operator (asphalt); Mechanic; Pump operator (6-in. discharge or over, gas, diesel powered or generator of 300 amp. or larger); Shouldering or gravel distributing machine operator (self-propelled); Backhoe (with over 3/8 yd. bucket); Side boom tractor (type D-4 or equivalent or larger); Tube finisher (slip form paving); Gradall (and similar type machine); Asphalt paver (self-propelled); Asphalt planer (self-propelled); Batch plant (concrete-central mix); Slurry machine (asphalt); Concrete pump (3 in. and over); Roto-mill; Swinging boom truck (over 12 ton capacity); Hydro demolisher (water blaster); Farm-type tractor with attached pan

GROUP 2: Screening plant operator; Washing plant operator; Crusher operator; Backhoe (with 3/8 yd. bucket or less); Side boom tractor (smaller than D-4 type or equivalent); Sweeper (Wayne type and similar equipment); Vacuum truck operator; Batch plant (concrete dry batch)

GROUP 3: Grease Truck

GROUP 4: Air compressor operator (600 cu. ft. per min or more); Air compressor operator (two or more, less than 600 cfm); Wagon drill operator; Concrete breaker; Tractor operator (farm type with attachment)

GROUP 5: Boiler fire tender; Oiler; Fire tender; Trencher (service); Flexplane operator; Cleftplane operator; Grader operator (self-propelled fine-grade or form (concrete)); Finishing machine operator (concrete); Boom or winch hoist truck operator; Endloader operator (under 1 yd. capacity); Roller operator (other than asphalt); Curing equipment operator (self-propelled); Concrete saw operator (40 h.p. or over); Power bin operator; Plant drier operator (asphalt); Vibratory compaction equipment operator (6 ft. wide or over); Guard post driver operator (power driven); All mulching equipment; Stump remover; Concrete pump (under 3-in.); Mesh installer (self-propelled); Tractor operator (farm type); End dump; Skid steer

ENGI0324-007 05/01/2016

ALGER, BARAGA, CHIPPEWA, DELTA, DICKINSON, GOGEBIC, HOUGHTON,
IRON, KEWEENAW, LUCE, MACKINAC MARQUETTE, MENOMINEE, ONTONAGON
AND SCHOOLCRAFT COUNTIES:

	Rates	Fringes
OPERATOR: Power Equipment (Steel Erection)		
Compressor, welder and forklift.....	\$ 25.46	22.55
Crane operator, main boom & jib 120' or longer.....	\$ 29.21	22.55
Crane operator, main boom & jib 140' or longer.....	\$ 29.46	22.55
Crane operator, main boom & jib 220' or longer.....	\$ 29.71	22.55
Mechanic with truck and tools.....	\$ 30.21	22.55
Oiler and fireman.....	\$ 24.16	22.55
Regular operator.....	\$ 28.71	22.55

ENGI0324-008 10/01/2015

ALCONA, ALGER, ALLEGAN, ALPENA, ANTRIM, ARENAC, BARAGA, BARRY,
BAY, BENZIE, BERRIEN, BRANCH, CALHOUN, CASS, CHARLEVOIX,
CHEBOYGAN, CHIPPEWA, CLARE, CLINTON, CRAWFORD, DELTA,
DICKINSON, EATON, EMMET, GENESEE, GLADWIN, GOGEBIC, GRAND
TRAVERSE, GRATIOT, HILLSDALE, HOUGHTON, HURON, INGHAM, IONIA,
IOSCO, IRON, ISABELLA, JACKSON, KALAMAZOO, KALKASKA, KENT,
KEWEENAW, LAKE, LAPEER, LEELANAU, LENAWEE, LIVINGSTON, LUCE,
MACKINAC, MACOMB, MANISTEE, MARQUETTE, MASON, MECOSTA,
MENOMINEE, MIDLAND, MISSAUKEE, MONTCALM, MONTMORENCY, MONROE,
MUSKOGON, NEWAYGO, OAKLAND, OCEANA, OGEMAW, ONTONAGON, OSCEOLA,
OSCODA, OTSEGO, OTTAWA, PRESQUE ISLE, ROSCOMMON, SAGINAW, ST.
CLARE, ST. JOSEPH, SANILAC, SCHOOLCRAFT, SHIAWASSEE, TUSCOLA,
VAN BUREN, WASHTENAW, WAYNE AND WEXFORD COUNTIES

	Rates	Fringes
OPERATOR: Power Equipment (Sewer Relining)		
GROUP 1.....	\$ 30.70	12.93
GROUP 2.....	\$ 29.17	12.93

SEWER RELINING CLASSIFICATIONS

GROUP 1: Operation of audio-visual closed circuit TV system,
including remote in-ground cutter and other equipment used
in connection with the CCTV system

GROUP 2: Operation of hot water heaters and circulation
systems, water jettors and vacuum and mechanical debris
removal systems

ENGI0325-012 05/01/2016

AREA 1: MACOMB, MONROE, OAKLAND, ST. CLAIR, WASHTENAW AND WAYNE
COUNTIES

AREA 2: ALCONA, ALGER, ALLEGAN, ALPENA, ANTRIM, ARENAC, BARAGA, BARRY, BAY, BENZIE, BERRIEN, BRANCH, CALHOUN, CASS, CHARLEVOIX, CHEBOYGAN, CHIPPEWA, CLARE, CLINTON, CRAWFORD, DELTA, DICKINSON, EATON, EMMET, GENESEE, GLADWIN, GOGEBIC, GRAND TRAVERSE, GRATIOT, HILLSDALE, HOUGHTON, HURON, INGHAM, IONIA, IOSCO, IRON, ISABELLA, JACKSON, KALAMAZOO, KALKASKA, KENT, KEWEENAW, LAKE, LAPEER, LEELANAU, LENAWEE, LIVINGSTON LUCE, MACKINAC, MANISTEE, MARQUETTE, MASON, MECOSTA, MENOMINEE, MIDLAND, MISSAUKEE, MONTCALM, MONTMORENCY, MUSKEGON, NEWAYGO, OCEANA, OGEMAW, ONTONAGON, OSCEOLA, OSCODA, OTSEGO, OTTAWA, PRESQUE ISLE, ROSCOMMON, SAGINAW, ST. JOSEPH, SANILAC, SCHOOLCRAFT, SHIAWASSEE, TUSCOLA, VAN BUREN AND WEXFORD COUNTIES

	Rates	Fringes
Power equipment operators -		
gas distribution and duct		
installation work:		
AREA 1		
GROUP 1.....	\$ 29.23	22.80
GROUP 2.....	\$ 29.10	22.80
GROUP 3.....	\$ 27.98	22.80
GROUP 4.....	\$ 27.40	22.80
AREA 2		
GROUP 1.....	\$ 28.32	22.80
GROUP 2-A.....	\$ 28.22	22.80
GROUP 2-B.....	\$ 28.00	22.80
GROUP 3.....	\$ 27.22	22.80
GROUP 4.....	\$ 26.72	22.80

SCOPE OF WORK: The construction, installation, treating and reconditioning of pipelines transporting gas vapors within cities, towns, subdivisions, suburban areas, or within private property boundaries, up to and including private meter settings of private industrial, governmental or other premises, more commonly referred to as "distribution work," starting from the first metering station, connection, similar or related facility, of the main or cross country pipeline and including duct installation.

AREA 1:

- GROUP 1: Backhoe, crane, grader, mechanic, dozer (D-6 equivalent or larger), side boom (D-4 equivalent or larger), trencher(except service), endloader (2 yd. capacity or greater).
- GROUP 2: Dozer (less than D-6 equivalent), endloader (under 2 yd. capacity), side boom (under D-4 capacity), backfiller, pumps (1 or 2 of 6-inch discharge or greater), boom truck (with powered boom), tractor (wheel type other than backhoe or front endloader).
- GROUP 3: Tamper (self-propelled), boom truck (with non-powered boom), concrete saw (20 hp or larger), pumps (2 to 4 under 6-inch discharge), compressor (2 or more or when one is used continuously into the second day) and trencher(service).
- GROUP 4: Oiler, hydraulic pipe pushing machine, grease person and hydrostatic testing operator.

AREA 2:

- GROUP 1: Mechanic, crane (over 1/2 yd. capacity), backhoe

(over 1/2 yd. capacity), grader (Caterpillar 12 equivalent or larger)

GROUP 2-A: Trencher(except service), backhoe (1/2 yd. capacity or less)

GROUP 2-B: Crane (1/2 yd. capacity or less), compressor (2 or more), dozer (D-4 equivalent or larger), endloader (1 yd. capacity or larger), pump (1 or 2 six-inch or larger), side boom (D-4 equivalent or larger)

GROUP 3: Backfiller, boom truck (powered), concrete saw (20 hp or larger), dozer (less than D-4 equivalent), endloader (under 1 yd. capacity), farm tractor (with attachments), pump (2 - 4 under six-inch capacity), side boom tractor(less than D-4 equivalent), tamper (self-propelled), trencher service and grader maintenance

GROUP 4: Oiler, grease person and hydrostatic testing operator

IRON0008-007 05/01/2015

ALGER, BARAGA, CHIPPEWA, DELTA, DICKINSON, GOGEBIC, HOUGHTON, IRON, KEWEENAW, LUCE, MACKINAC MARQUETTE, MENOMINEE, ONTONAGON AND SCHOOLCRAFT COUNTIES:

	Rates	Fringes
Ironworker - pre-engineered metal building erector.....	\$ 23.70	6.95
IRONWORKER		
General contracts		
\$10,000,000 or greater.....	\$ 26.52	24.35
General contracts less than \$10,000,000.....	\$ 23.11	24.35

Paid Holidays: New Year's Day, Memorial Day, July 4th, Labor Day, Thanksgiving Day & Christmas Day.

IRON0025-002 06/01/2015

ALCONA, ALPENA, ARENAC, BAY, CHEBOYGAN, CLARE, CLINTON, CRAWFORD, GENESEE, GLADWIN, GRATIOT, HURON, INGHAM, IOSCO, ISABELLA, JACKSON, LAPEER, LIVINGSTON, MACOMB, MIDLAND, MONTMORENCY, OAKLAND, OGEMAW, OSCODA, OTSEGO, PRESQUE ISLE, ROSCOMMON, SAGINAW, SANILAC, SHIAWASSEE, ST. CLAIR, TUSCOLA, WASHTENAW AND WAYNE COUNTIES:

	Rates	Fringes
Ironworker - pre-engineered metal building erector		
Alcona, Alpena, Arenac, Cheboygan, Clare, Clinton, Crawford, Gladwin, Gratiot, Huron, Ingham, Iosco, Isabella, Jackson, Lapeer, Livingston (west of Burkhardt Road), Montmorency, Ogemaw, Oscoda, Otsego, Presque Isle, Roscommon, Sanilac,		

Shiawassee, Tuscola & Washtenaw (west of U.S. 23).	\$ 22.17	20.13
Bay, Genesee, Lapeer, Livingston (east of Burkhardt Road), Macomb, Midland, Oakland, Saginaw, St. Clair, The University of Michigan, Washtenaw (east of U.S. 23) & Wayne...	\$ 23.39	21.13
IRONWORKER		
Ornamental and Structural...	\$ 33.78	27.84
Reinforcing.....	\$ 28.30	24.60

IRON0055-005 07/01/2013

LENAWEE AND MONROE COUNTIES:

	Rates	Fringes
IRONWORKER		
Pre-engineered metal buildings.....	\$ 23.59	19.35
All other work.....	\$ 28.32	19.35

IRON0292-003 06/01/2016

BERRIEN AND CASS COUNTIES:

	Rates	Fringes
IRONWORKER (Including pre-engineered metal building erector).....		
	\$ 28.81	20.16

IRON0340-001 06/01/2015

ALLEGAN, ANTRIM, BARRY, BENZIE, BRANCH, CALHOUN, CHARLEVOIX,
EATON, EMMET, GRAND TRAVERSE, HILLSDALE, IONIA, KALAMAZOO,
KALKASKA, KENT, LAKE, LEELANAU, MANISTEE, MASON, MECOSTA,
MISSAUKEE, MONTCALM, MUSKEGON, NEWAYGO, OCEANA, OSCEOLA,
OTTAWA, ST. JOSEPH, VAN BUREN AND WEXFORD COUNTIES:

	Rates	Fringes
IRONWORKER (Including pre-engineered metal building erector).....		
	\$ 21.68	24.37

LABO0005-006 10/01/2014

	Rates	Fringes
Laborers - hazardous waste abatement: (ALCONA, ALPENA, ANTRIM, BENZIE, CHARLEVOIX, CHEBOYGAN, CRAWFORD, EMMET, GRAND TRAVERSE, IOSCO, KALKASKA, LEELANAU, MISSAUKEE, MONTMORENCY, OSCODA, OTSEGO, PRESQUE ISLE AND WEXFORD COUNTIES - Zone 10)		
Levels A, B or C.....	\$ 17.45	12.75
Work performed in conjunction with site		

preparation not requiring the use of personal protective equipment;		
Also, Level D.....\$ 16.45		12.75
Laborers - hazardous waste abatement: (ALGER, BARAGA, CHIPPEWA, DELTA, DICKINSON, GOGEBIC, HOUGHTON, IRON, KEWEENAW, LUCE, MACKINAC, MARQUETTE, MENOMINEE, ONTONAGON AND SCHOOLCRAFT COUNTIES - Zone 11)		
Levels A, B or C.....\$ 20.91		12.78
Work performed in conjunction with site preparation not requiring the use of personal protective equipment;		
Also, Level D.....\$ 19.91		12.78
Laborers - hazardous waste abatement: (ALLEGAN, BARRY, BERRIEN, BRANCH, CALHOUN, CASS, IONIA COUNTY (except the city of Portland); KALAMAZOO, KENT, LAKE, MANISTEE, MASON, MECOSTA, MONTCALM, MUSKEGON, NEWAYGO, OCEANA, OSCEOLA, OTTAWA, ST. JOSEPH AND VAN BUREN COUNTIES - Zone 9)		
Levels A, B or C.....\$ 19.99		12.75
Work performed in conjunction with site preparation not requiring the use of personal protective equipment;		
Also, Level D.....\$ 18.99		12.75
Laborers - hazardous waste abatement: (ARENAC, BAY, CLARE, GLADWIN, GRATIOT, HURON, ISABELLA, MIDLAND, OGEMAW, ROSCOMMON, SAGINAW AND TUSCOLA COUNTIES - Zone 8)		
Levels A, B or C.....\$ 20.02		12.75
Work performed in conjunction with site preparation not requiring the use of personal protective equipment;		
Also, Level D.....\$ 19.02		12.75
Laborers - hazardous waste abatement: (CLINTON, EATON AND INGHAM COUNTIES; IONIA COUNTY (City of Portland); LIVINGSTON COUNTY (west of Oak Grove Rd., including the City of Howell) - Zone 6)		
Levels A, B or C.....\$ 23.29		12.75
Work performed in conjunction with site preparation not requiring the use of personal protective equipment;		
Also, Level D.....\$ 22.29		12.75
Laborers - hazardous waste abatement: (GENESEE, LAPEER		

AND SHIAWASSEE COUNTIES -

Zone 7)

Levels A, B or C.....\$ 23.40 12.79
 Work performed in
 conjunction with site
 preparation not requiring
 the use of personal
 protective equipment;

Also, Level D.....\$ 22.40 12.79

Laborers - hazardous waste
 abatement: (HILLSDALE,
 JACKSON AND LENAWEE COUNTIES

- Zone 4)

Levels A, B or C.....\$ 30.00 14.09
 Work performed in
 conjunction with site
 preparation not requiring
 the use of personal
 protective equipment;

Also, Level D.....\$ 29.00 14.09

Laborers - hazardous waste
 abatement: (LIVINGSTON COUNTY
 (east of Oak Grove Rd. and
 south of M-59, excluding the
 city of Howell); AND

WASHTENAW COUNTY - Zone 3)

Levels A, B or C.....\$ 29.32 13.85
 Work performed in
 conjunction with site
 preparation not requiring
 the use of personal
 protective equipment;

Also, Level D.....\$ 28.32 13.85

Laborers - hazardous waste
 abatement: (MACOMB AND WAYNE
 COUNTIES - Zone 1)

Levels A, B or C.....\$ 27.94 16.55
 Work performed in
 conjunction with site
 preparation not requiring
 the use of personal
 protective equipment;

Also, Level D.....\$ 26.94 16.55

Laborers - hazardous waste
 abatement: (MONROE COUNTY -
 Zone 4)

Levels A, B or C.....\$ 30.00 14.09
 Work performed in
 conjunction with site
 preparation not requiring
 the use of personal
 protective equipment;

Also, Level D.....\$ 29.00 14.09

Laborers - hazardous waste
 abatement: (OAKLAND COUNTY
 and the Northeast portion of
 LIVINGSTON COUNTY bordered by
 Oak Grove Road on the West
 and M-59 on the South - Zone

2)

Level A, B, C.....\$ 27.94 16.55
 Work performed in
 conjunction with site
 preparation not requiring
 the use of personal
 protective equipment;

Also, Level D.....	\$ 26.94	16.55
Laborers - hazardous waste abatement: (SANILAC AND ST. CLAIR COUNTIES - Zone 5)		
Levels A, B or C.....	\$ 24.97	15.19
Work performed in conjunction with site preparation not requiring the use of personal protective equipment;		
Also, Level D.....	\$ 23.97	15.19

LABO0259-001 09/01/2016

AREA 1: MACOMB, OAKLAND AND WAYNE COUNTIES
 AREA 2: ALCONA, ALGER, ALLEGAN, ALPENA, ANTRIM, ARENAC, BARAGA, BARRY, BAY, BENZIE, BERRIEN, BRANCH, CALHOUN, CASS, CHARLEVOIX, CHEBOYGAN, CHIPPEWA, CLARE, CLINTON, CRAWFORD, DELTA, DICKINSON, EATON, EMMET, GENESEE, GLADWIN, GOGEBIC, GRAND TRAVERSE, GRATIOT, HILLSDALE, HOUGHTON, HURON, INGHAM, IONIA, IOSCO, IRON, ISABELLA, JACKSON, KALAMAZOO, KALKASKA, KENT, KEWEENAW, LAKE, LAPEER, LEELANAU, LENAWEE, LIVINGSTON, LUCE, MACKINAC, MANISTEE, MARQUETTE, MASON, MECOSTA, MENOMINEE, MIDLAND, MISSAUKEE, MONROE, MONTCALM, MONTMORENCY, MUSKEGON, NEWAYGO, OCEANA, OGEMAW, ONTONAGON, OSCEOLA, OSCODA, OTSEGO, OTTAWA, PRESQUE ISLE, ROSCOMMON, SAGINAW, ST. CLARE, ST. JOSEPH, SANILAC, SCHOOLCRAFT, SHIAWASSEE, TUSCOLA, VAN BUREN, WASHTENAW AND WEXFORD COUNTIES

	Rates	Fringes
Laborers - tunnel, shaft and caisson:		
AREA 1		
GROUP 1.....	\$ 21.87	16.70
GROUP 2.....	\$ 21.98	16.70
GROUP 3.....	\$ 22.04	16.70
GROUP 4.....	\$ 22.22	16.70
GROUP 5.....	\$ 22.47	16.70
GROUP 6.....	\$ 22.80	16.70
GROUP 7.....	\$ 16.08	16.70
AREA 2		
GROUP 1.....	\$ 23.35	12.85
GROUP 2.....	\$ 23.44	12.85
GROUP 3.....	\$ 23.54	12.85
GROUP 4.....	\$ 23.70	12.85
GROUP 5.....	\$ 23.96	12.85
GROUP 6.....	\$ 24.27	12.85
GROUP 7.....	\$ 16.54	12.88

SCOPE OF WORK: Tunnel, shaft and caisson work of every type and description and all operations incidental thereto, including, but not limited to, shafts and tunnels for sewers, water, subways, transportation, diversion, sewerage, caverns, shelters, aquifers, reservoirs, missile silos and steel sheeting for underground construction.

TUNNEL LABORER CLASSIFICATIONS

- GROUP 1: Tunnel, shaft and caisson laborer, dump, shanty, hog house tender, testing (on gas) and watchman
- GROUP 2: Manhole, headwall, catch basin builder, bricklayer tender, mortar machine and material mixer

GROUP 3: Air tool operator (jackhammer, bush hammer and grinder), first bottom, second bottom, cage tender, car pusher, carrier, concrete, concrete form, concrete repair, cement invert laborer, cement finisher, concrete shoveler, conveyor, floor, gasoline and electric tool operator, gunite, grout operator, welder, heading dinky person, inside lock tender, pea gravel operator, pump, outside lock tender, scaffold, top signal person, switch person, track, tugger, utility person, vibrator, winch operator, pipe jacking, wagon drill and air track operator and concrete saw operator (under 40 h.p.)

GROUP 4: Tunnel, shaft and caisson mucker, bracer, liner plate, long haul dinky driver and well point

GROUP 5: Tunnel, shaft and caisson miner, drill runner, key board operator, power knife operator, reinforced steel or mesh (e.g. wire mesh, steel mats, dowel bars, etc.)

GROUP 6: Dynamite and powder

GROUP 7: Restoration laborer, seeding, sodding, planting, cutting, mulching and top soil grading; and the restoration of property such as replacing mailboxes, wood chips, planter boxes, flagstones, etc.

LABO0334-001 09/01/2016

	Rates	Fringes
Laborers - open cut:		
ZONE 1 - MACOMB, OAKLAND AND WAYNE COUNTIES:		
GROUP 1.....	\$ 21.72	16.70
GROUP 2.....	\$ 21.83	16.70
GROUP 3.....	\$ 21.85	16.70
GROUP 4.....	\$ 21.96	16.70
GROUP 5.....	\$ 22.02	16.70
GROUP 6.....	\$ 19.47	16.70
GROUP 7.....	\$ 16.09	16.70
ZONE 2 - LIVINGSTON COUNTY (east of M-151 (Oak Grove Rd.)); MONROE AND WASHTENAW COUNTIES:		
GROUP 1.....	\$ 23.00	12.85
GROUP 2.....	\$ 23.11	12.85
GROUP 3.....	\$ 23.23	12.85
GROUP 4.....	\$ 23.30	12.85
GROUP 5.....	\$ 23.45	12.85
GROUP 6.....	\$ 20.75	12.85
GROUP 7.....	\$ 17.39	12.85
ZONE 3 - CLINTON, EATON, GENESEE, HILLSDALE AND INGHAM COUNTIES; IONIA COUNTY (City of Portland); JACKSON, LAPEER AND LENAWEE COUNTIES; LIVINGSTON COUNTY (west of M-151 Oak Grove Rd.); SANILAC, ST. CLAIR AND SHIAWASSEE COUNTIES:		
GROUP 1.....	\$ 21.19	12.85
GROUP 2.....	\$ 21.33	12.85
GROUP 3.....	\$ 21.45	12.85
GROUP 4.....	\$ 21.50	12.85

GROUP 5.....	\$ 21.64	12.85
GROUP 6.....	\$ 18.94	12.85
GROUP 7.....	\$ 16.09	12.85
ZONE 4 - ALCONA, ALLEGAN, ALPENA, ANTRIM, ARENAC, BARRY, BAY, BENZIE, BERRIEN, BRANCH, CALHOUN, CASS, CHARLEVOIX, CHEBOYGAN, CLARE, CRAWFORD, EMMET, GLADWIN, GRAND TRAVERSE, GRATIOT AND HURON COUNTIES; IONIA COUNTY (EXCEPT THE CITY OF PORTLAND); IOSCO, ISABELLA, KALAMAZOO, KALKASKA, KENT, LAKE, LEELANAU, MANISTEE, MASON, MECOSTA, MIDLAND, MISSAUKEE, MONTCALM, MONTMORENCY, MUSKEGON, NEWAYGO, OCEANA, OGEMAW, OSCEOLA, OSCODA, OTSEGO, OTTAWA, PRESQUE ISLE, ROSCOMMON, SAGINAW, ST. JOSEPH, TUSCOLA, VAN BUREN AND WEXFORD COUNTIES:		
GROUP 1.....	\$ 20.20	12.85
GROUP 2.....	\$ 20.33	12.85
GROUP 3.....	\$ 20.44	12.85
GROUP 4.....	\$ 20.51	12.85
GROUP 5.....	\$ 20.63	12.85
GROUP 6.....	\$ 17.85	12.85
GROUP 7.....	\$ 16.19	12.85
ZONE 5 - ALGER, BARAGA, CHIPPEWA, DELTA, DICKINSON, GOGEBIC, HOUGHTON, IRON, KEWEENAW, LUCE, MACKINAC, MARQUETTE, MENOMINEE, ONTONAGON AND SCHOOLCRAFT COUNTIES:		
GROUP 1.....	\$ 20.51	12.85
GROUP 2.....	\$ 20.65	12.85
GROUP 3.....	\$ 20.78	12.85
GROUP 4.....	\$ 20.83	12.85
GROUP 5.....	\$ 20.88	12.85
GROUP 6.....	\$ 18.26	12.85
GROUP 7.....	\$ 16.37	12.85

SCOPE OF WORK:

Open cut construction work shall be construed to mean work which requires the excavation of earth including industrial, commercial and residential building site excavation and preparation, land balancing, demolition and removal of concrete and underground appurtenances, grading, paving, sewers, utilities and improvements; retention, oxidation, flocculation and irrigation facilities, and also including but not limited to underground piping, conduits, steel sheeting for underground construction, and all work incidental thereto, and general excavation. For all areas except the Upper Peninsula, open cut construction work shall also be construed to mean waterfront work, piers, docks, seawalls, breakwalls, marinas and all incidental work. Open cut construction work shall not include any

structural modifications, alterations, additions and repairs to buildings, or highway work, including roads, streets, bridge construction and parking lots or steel erection work and excavation for the building itself and back filling inside of and within 5 ft. of the building and foundations, footings and piers for the building. Open cut construction work shall not include any work covered under Tunnel, Shaft and Caisson work.

OPEN CUT LABORER CLASSIFICATIONS

GROUP 1: Construction laborer

GROUP 2: Mortar and material mixer, concrete form person, signal person, well point person, manhole, headwall and catch basin builder, headwall, seawall, breakwall and dock builder

GROUP 3: Air, gasoline and electric tool operator, vibrator operator, driller, pump person, tar kettle operator, bracer, rodder, reinforced steel or mesh person (e.g., wire mesh, steel mats, dowel bars, etc.), welder, pipe jacking and boring person, wagon drill and air track operator and concrete saw operator (under 40 h.p.), windlass and tugger person and directional boring person

GROUP 4: Trench or excavating grade person

GROUP 5: Pipe layer (including crock, metal pipe, multi-plate or other conduits)

GROUP 6: Grouting man, audio-visual television operations and all other operations in connection with closed circuit television inspection, pipe cleaning and pipe relining work and the installation and repair of water service pipe and appurtenances

GROUP 7: Restoration laborer, seeding, sodding, planting, cutting, mulching and top soil grading; and the restoration of property such as replacing mailboxes, wood chips, planter boxes, flagstones, etc.

LABO0465-001 06/01/2016

LABORER: Highway, Bridge and Airport Construction

AREA 1: GENESEE, MACOMB, MONROE, OAKLAND, WASHTENAW AND WAYNE COUNTIES

AREA 2: ALLEGAN, BARRY, BAY, BERRIEN, BRANCH, CALHOUN, CASS, CLINTON, EATON, GRATIOT, HILLSDALE, HURON, INGHAM, JACKSON, KALAMAZOO, LAPEER, LENAWEE, LIVINGSTON, MIDLAND, MUSKEGON, SAGINAW, SANILAC, SHIAWASSEE, ST. CLAIR, ST. JOSEPH, TUSCOLA AND VAN BUREN COUNTIES

AREA 3: ALCONA, ALPENA, ANTRIM, ARENAC, BENZIE, CHARLEVOIX, CHEBOYGAN, CLARE, CRAWFORD, EMMET, GLADWIN, GRAND TRAVERSE, IONIA, IOSCO, ISABELLA, KALKASKA, KENT, LAKE, LEELANAU, MANISTEE, MASON, MECOSTA, MISSAUKEE, MONTCALM, MONTMORENCY, NEWAYGO, OCEANA, OGEMAW, OSCEOLA, OSCODA, OTSEGO, OTTAWA, PRESQUE ISLE, ROSCOMMON AND WEXFORD COUNTIES

AREA 4: ALGER, BARAGA, CHIPPEWA, DELTA, DICKINSON, GOGEBIC, HOUGHTON, IRON, KEWEENAW, LUCE, MACKINAC, MARQUETTE, MENOMINEE, ONTONAGON AND SCHOOLCRAFT COUNTIES

	Rates	Fringes
LABORER (AREA 1)		
GROUP 1.....	\$ 22.32	15.89
GROUP 2.....	\$ 22.45	15.89
GROUP 3.....	\$ 22.63	15.89
GROUP 4.....	\$ 22.71	15.89
GROUP 5.....	\$ 22.92	15.89
GROUP 6.....	\$ 23.22	15.89
LABORER (AREA 2)		
GROUP 1.....	\$ 20.41	15.75
GROUP 2.....	\$ 20.61	15.75
GROUP 3.....	\$ 20.85	15.75
GROUP 4.....	\$ 21.20	15.75
GROUP 5.....	\$ 21.07	15.75
GROUP 6.....	\$ 21.41	15.75
LABORER (AREA 3)		
GROUP 1.....	\$ 19.66	15.75
GROUP 2.....	\$ 19.87	15.75
GROUP 3.....	\$ 20.16	15.75
GROUP 4.....	\$ 20.60	15.75
GROUP 5.....	\$ 20.22	15.75
GROUP 6.....	\$ 20.65	15.75
LABORER (AREA 4)		
GROUP 1.....	\$ 19.66	15.75
GROUP 2.....	\$ 19.87	15.75
GROUP 3.....	\$ 20.16	15.75
GROUP 4.....	\$ 20.60	15.75
GROUP 5.....	\$ 20.22	15.75
GROUP 6.....	\$ 20.65	15.75

LABORER CLASSIFICATIONS

GROUP 1: Asphalt shoveler or loader; asphalt plant misc.; burlap person; yard person; dumper (wagon, truck, etc.); joint filling laborer; miscellaneous laborer; unskilled laborer; sprinkler laborer; form setting laborer; form stripper; pavement reinforcing; handling and placing (e.g., wire mesh, steel mats, dowel bars); mason's tender or bricklayer's tender on manholes; manhole builder; headwalls, etc.; waterproofing, (other than buildings) seal coating and slurry mix, shoring, underpinning; pressure grouting; bridge pin and hanger removal; material recycling laborer; horizontal paver laborer (brick, concrete, clay, stone and asphalt); ground stabilization and modification laborer; grouting; waterblasting; top person; railroad track and trestle laborer; carpenters' tender; guard rail builders' tender; earth retention barrier and wall and M.S.E. wall installer's tender; highway and median installer's tender (including sound, retaining, and crash barriers); fence erector's tender; asphalt raker tender; sign installer; remote control operated equipment.

GROUP 2: Mixer operator (less than 5 sacks); air or electric tool operator (jackhammer, etc.); spreader; boxperson (asphalt, stone, gravel); concrete paddler; power chain saw operator; paving batch truck dumper; tunnel mucker (highway work only); concrete saw (under 40 h.p.) and dry pack machine; roto-mill grounds person.

GROUP 3: Tunnel miner (highway work only); finishers tenders; guard rail builders; highway and median barrier installer; earth retention barrier and wall and M.S.E. wall installer's (including sound, retaining and crash

barriers); fence erector; bottom person; powder person; wagon drill and air track operator; diamond and core drills; grade checker; certified welders; curb and side rail setter's tender.

GROUP 4: Asphalt raker

GROUP 5: Pipe layers, oxy-gun

GROUP 6: Line-form setter for curb or pavement; asphalt screed checker/screw man on asphalt paving machines.

LABO1076-005 04/01/2016

MICHIGAN STATEWIDE

	Rates	Fringes
LABORER (DISTRIBUTION WORK)		
Zone 1.....	\$ 19.77	12.85
Zone 2.....	\$ 18.15	12.85
Zone 3.....	\$ 16.38	12.85
Zone 4.....	\$ 15.75	12.85
Zone 5.....	\$ 15.75	12.85

DISTRIBUTION WORK - The construction, installation, treating and reconditioning of distribution pipelines transporting coal, oil, gas or other similar materials, vapors or liquids, including pipelines within private property boundaries, up to and including the meter settings on residential, commercial, industrial, institutional, private and public structures. All work covering pumping stations and tank farms not covered by the Building Trades Agreement. Other distribution lines with the exception of sewer, water and cable television are included.

Underground Duct Layer Pay: \$.40 per hour above the base pay rate.

- Zone 1 - Macomb, Oakland and Wayne
- Zone 2 - Monroe and Washtenaw
- Zone 3 - Bay, Genesee, Lapeer, Midland, Saginaw, Sanilac, Shiawassee and St. Clair
- Zone 4 - Alger, Baraga, Chippewa, Delta, Dickinson, Gogebic, Houghton, Iron, Keweenaw, Luce, Mackinac, Marquette, Menominee, Ontonagon and Schoolcraft
- Zone 5 - Remaining Counties in Michigan

PAIN0022-002 07/01/2008

HILLSDALE, JACKSON AND LENAWEE COUNTIES; LIVINGSTON COUNTY (east of the eastern city limits of Howell, not including the city of Howell, north to the Genesee County line and south to the Washtenaw County line); MACOMB, MONROE, OAKLAND, WASHTENAW AND WAYNE COUNTIES:

	Rates	Fringes
PAINTER.....	\$ 25.06	14.75

FOOTNOTES: For all spray work and journeyman rigging for spray work, also blowing off, \$0.80 per hour additional (applies only to workers doing rigging for spray work on

off the floor work. Does not include setting up or moving rigging on floor surfaces, nor does it apply to workers engaged in covering up or tending spray equipment. For all sandblasting and spray work performed on highway bridges, overpasses, tanks or steel, \$0.80 per hour additional. For all brushing, cleaning and other preparatory work (other than spraying or steeplejack work) at scaffold heights of fifty (50) feet from the ground or higher, \$0.50 per hour additional. For all preparatorial work and painting performed on open steel under forty (40) feet when no scaffolding is involved, \$0.50 per hour additional. For all swing stage work-window jacks and window belts-exterior and interior, \$0.50 per hour additional. For all spray work and sandblaster work to a scaffold height of forty (40) feet above the floor level, \$0.80 per hour additional. For all preparatorial work and painting on all highway bridges or overpasses up to forty (40) feet in height, \$0.50 per hour additional. For all steeplejack work performed where the elevation is forty (40) feet or more, \$1.25 per hour additional.

 PAIN0312-001 06/12/2014

EXCLUDES: ALLEGAN COUNTY (Townships of Dorr, Fillmore, Heath, Hopkins, Laketown, Leighton, Manlius, Monterey, Overisel, Salem, Saugatuck and Wayland); INCLUDES: Barry, Berrien, Branch, Calhoun, Cass, Hillsdale, Kalamazoo, St. Joseph, Van Buren

	Rates	Fringes
PAINTER		
Brush and roller.....	\$ 21.75	11.94
Spray, Sandblast, Sign		
Painting.....	\$ 22.75	11.94

 PAIN0845-003 05/21/2014

CLINTON COUNTY; EATON COUNTY (does not include the townships of Bellevue and Olivet); INGHAM COUNTY; IONIA COUNTY (east of Hwy. M 66); LIVINGSTON COUNTY (west of the eastern city limits of Howell, including the city of Howell, north to the Genesee County line and south to the Washtenaw County line); AND SHIAWASSEE COUNTY (Townships of Bennington, Laingsbury and Perry):

	Rates	Fringes
PAINTER.....	\$ 21.89	11.85

 PAIN0845-015 05/21/2014

MUSKEGON COUNTY; NEWAYGO COUNTY (except the Townships of Barton, Big Prairie, Brooks, Croton, Ensley, Everett, Goodwell, Grant, Home, Monroe, Norwich and Wilcox); OCEANA COUNTY; OTTAWA COUNTY (except the townships of Allendale, Blendone, Chester, Georgetown, Holland, Jamestown, Olive, Park, Polkton, Port Sheldon, Tallmadge, Wright and Zeeland):

	Rates	Fringes
PAINTER.....	\$ 21.89	11.85

PAIN0845-018 05/21/2014

ALLEGAN COUNTY (Townships of Dorr, Fillmore, Heath, Hopkins, Laketown, Leighton, Manlius, Monterey, Overisel, Salem, Saugatuck and Wayland); IONIA COUNTY (west of Hwy. M-66); KENT, MECOSTA AND MONTCALM COUNTIES; NEWAYGO COUNTY (Townships of Barton, Big Prairie, Brooks, Croton, Ensley, Everett, Goodwell, Grant, Home, Monroe, Norwich and Wilcox); OSCEOLA COUNTY (south of Hwy. #10); OTTAWA COUNTY (Townships of Allendale, Blendone, Chester, Georgetown, Holland, Jamestown, Olive, Park, Polkton, Port Sheldon, Tallmadge, Wright and Zeeland):

	Rates	Fringes
PAINTER.....	\$ 21.89	11.85

FOOTNOTES: Lead abatement work: \$1.00 per hour additional.

PAIN1011-003 06/05/2014

ALGER, BARAGA, CHIPPEWA, DELTA, DICKINSON, GOGEBIC, HOUGHTON, IRON, KEWEENAW, LUCE, MACKINAC, MARQUETTE, MENOMINEE, ONTONAGON AND SCHOOLCRAFT COUNTIES:

	Rates	Fringes
PAINTER.....	\$ 24.15	10.52

FOOTNOTES: High pay (bridges, overpasses, watertower): 30 to 80 ft.: \$.65 per hour additional. 80 ft. and over: \$1.30 per hour additional.

PAIN1474-002 06/01/2010

HURON COUNTY; LAPEER COUNTY (east of Hwy. M-53); ST. CLAIR, SANILAC AND TUSCOLA COUNTIES:

	Rates	Fringes
PAINTER.....	\$ 23.79	12.02

FOOTNOTES: Lead abatement work: \$1.00 per hour additional. Work with any hazardous material: \$1.00 per hour additional. Sandblasting, steam cleaning and acid cleaning: \$1.00 per hour additional. Ladder work at or above 40 ft., scaffold work at or above 40 ft., swing stage, boatswain chair, window jacks and all work performed over a falling height of 40 ft.: \$1.00 per hour additional. Spray gun work, pick pullers and those handling needles, blowing off by air pressure, and any person rigging (setting up and moving off the ground): \$1.00 per hour additional. Steeplejack, tanks, gas holders, stacks, flag poles, radio towers and beacons, power line towers, bridges, etc.: \$1.00 per hour additional, paid from the ground up.

PAIN1803-003 06/01/2016

ALCONA, ALPENA, ANTRIM, ARENAC, BAY, BENZIE, CHARLEVOIX, CHEBOYGAN, CLARE, CRAWFORD, EMMET, GLADWIN, GRAND TRAVERSE, GRATIOT, IOSCO, ISABELLA, KALKASKA, LAKE, LEELANAU, MANISTEE,

MASON, MIDLAND, MISSAUKEE, MONTMORENCY AND OGEMAW COUNTIES;
 OSCEOLA COUNTY (north of Hwy. #10); OSCODA, OTSEGO, PRESQUE
 ISLE, ROSCOMMON, SAGINAW AND WEXFORD COUNTIES:

Rates Fringes

PAINTER

Work performed on water,
 bridges over water or
 moving traffic, radio and
 powerline towers, elevated
 tanks, steeples, smoke
 stacks over 40 ft. of
 falling heights, recovery
 of lead-based paints and
 any work associated with
 industrial plants, except
 maintenance of industrial

plants.....	\$ 25.10	13.15
All other work, including maintenance of industrial plant.....	\$ 23.68	13.15

FOOTNOTES: Spray painting, sandblasting, blowdown associated
 with spraying and blasting, water blasting and work
 involving a swing stage, boatswain chair or spider: \$1.00
 per hour additional. All work performed inside tanks,
 vessels, tank trailers, railroad cars, sewers, smoke
 stacks, boilers or other spaces having limited egress not
 including buildings, opentop tanks, pits, etc.: \$1.25 per
 hour additional.

 PLAS0514-001 06/01/2016

ZONE 1: GENESEE, LIVINGSTON, MACOMB, MONROE, OAKLAND, SAGINAW,
 WASHTENAW AND WAYNE COUNTIES

ZONE 2: ALCONA, ALGER, ALLEGAN, ALPENA, ANTRIM, ARENAC, BARAGA,
 BARRY, BAY, BENZIE, BERRIEN, BRANCH, CALHOUN, CASS, CHARLEVOIX,
 CHEBOYGAN, CHIPPEWA, CLARE, CLINTON, CRAWFORD, DELTA,
 DICKINSON, EATON, EMMET, GLADWIN, GOGEBIC, GRAND TRAVERSE,
 GRATIOT, HILLSDALE, HOUGHTON, HURON, INGHAM, IONIA, IOSCO,
 IRON, ISABELLA, JACKSON, KALAMAZOO, KALKASKA, KENT, KEWEENAW,
 LAKE, LAPEER, LEELANAU, LENAWEE, LUCE, MACKINAC, MANISTEE,
 MARQUETTE, MASON, MECOSTA, MENOMINEE, MIDLAND, MISSAUKEE,
 MONTCALM, MONTMORENCY, MUSKEGON, NEWAYGO, OCEANA, OGEMAW,
 ONTONAGON, OSCEOLA, OSCODA, OTSEGO, OTTAWA, PRESQUE ISLE,
 ROSCOMMON, SANILAC, SCHOOLCRAFT, SHIAWASSEE, ST. CLAIR, ST.
 JOSEPH, TUSCOLA, VAN BUREN AND WEXFORD COUNTIES

Rates Fringes

CEMENT MASON/CONCRETE FINISHER

ZONE 1.....	\$ 30.44	13.34
ZONE 2.....	\$ 28.94	13.34

 PLUM0190-003 05/01/2015

ALCONA, ALGER, ALLEGAN, ALPENA, ANTRIM, ARENAC, BARAGA, BARRY,
 BAY, BENZIE, BERRIEN, BRANCH, CALHOUN, CASS, CHARLEVOIX,
 CHEBOYGAN, CHIPPEWA, CLARE, CLINTON, CRAWFORD, DELTA,
 DICKINSON, EATON, EMMET, GENESEE, GLADWIN, GOGEBIC, GRAND

TRAVERSE, GRATIOT, HILLSDALE, HOUGHTON, HURON, INGHAM, IONIA, IOSCO, IRON, ISABELLA, JACKSON, KALAMAZOO, KALKASKA, KENT, KEWEENAW, LAKE, LAPEER, LEELANAU, LENAWEE, LIVINGSTON, LUCE, MACKINAC, MACOMB, MANISTEE, MARQUETTE, MASON, MECOSTA, MENOMINEE, MIDLAND, MISSAUKEE, MONTCALM, MONTMORENCY, MONROE, MUSKEGON, NEWAYGO, OAKLAND, OCEANA, OGEMAW, ONTONAGON, OSCEOLA, OSCODA, OTSEGO, OTTAWA, PRESQUE ISLE, ROSCOMMON, SAGINAW, ST. CLARE, ST. JOSEPH, SANILAC, SCHOOLCRAFT, SHIAWASSEE, TUSCOLA, VAN BUREN, WASHTENAW, WAYNE AND WEXFORD COUNTIES

Rates Fringes

Plumber/Pipefitter - gas
distribution pipeline:

Welding in conjunction
with gas distribution

pipeline work.....	\$ 33.03	20.19
All other work:.....	\$ 24.19	12.28

TEAM0007-004 06/01/2016

AREA 1: ALCONA, ALGER, ALLEGAN, ALPENA, ANTRIM, ARENAC, BARAGA, BARRY, BAY, BENZIE, BERRIEN, BRANCH, CALHOUN, CASS, CHARLEVOIX, CHEBOYGAN, CHIPPEWA, CLARE, CLINTON, CRAWFORD, DELTA, DICKINSON, EATON, EMMET, GLADWIN, GOGEBIC, GRAND TRAVERSE, GRATIOT, HILLSDALE, HOUGHTON, HURON, INGHAM, IONIA, IOSCO, IRON, ISABELLA, JACKSON, KALAMAZOO, KALKASKA, KENT, KEWEENAW, LAKE, LAPEER, LEELANAU, LENAWEE, LUCE, MACKINAC, MANISTEE, MARQUETTE, MASON, MECOSTA, MENOMINEE, MIDLAND, MISSAUKEE, MONTCALM, MONTMORENCY, MUSKEGON, NEWAYGO, OCEANA, OGEMAW, ONTONAGON, OSCEOLA, OSCODA, OTSEGO, OTTAWA, PRESQUE ISLE, ROSCOMMON, SAGINAW, SANILAC, SCHOOLCRAFT, SHIAWASSEE, ST. CLAIR, ST. JOSEPH, TUSCOLA, VAN BUREN AND WEXFORD COUNTIES

AREA 2: GENESEE, LIVINGSTON, MACOMB, MONROE, OAKLAND, WASHTENAW AND WAYNE COUNTIES

Rates Fringes

TRUCK DRIVER

AREA 1

Euclids, double bottoms

and lowboys.....	\$ 25.05	.50 + a+b
------------------	----------	-----------

Trucks under 8 cu. yds.....	\$ 24.80	.50 + a+b
-----------------------------	----------	-----------

Trucks, 8 cu. yds. and		
------------------------	--	--

over.....	\$ 24.90	.50 + a+b
-----------	----------	-----------

AREA 2

Euclids, double bottomms

and lowboys.....	\$ 24.895	.50 + a+b
------------------	-----------	-----------

Euclids, double bottoms		
-------------------------	--	--

and lowboys.....	\$ 25.15	.50 + a+b
------------------	----------	-----------

Trucks under 8 cu. yds.....	\$ 24.90	.50 + a+b
-----------------------------	----------	-----------

Trucks, 8 cu. yds. and		
------------------------	--	--

over.....	\$ 25.00	.50 + a+b
-----------	----------	-----------

Footnote:

a. \$438.45 per week

b. \$61.90 daily

TEAM0247-004 06/01/2004

AREA 1: ALCONA, ALGER, ALLEGAN, ALPENA, ANTRIM, ARENAC, BARAGA, BARRY, BAY, BENZIE, BERRIEN, BRANCH, CALHOUN, CASS, CHARLEVOIX, CHEBOYGAN, CHIPPEWA, CLARE, CLINTON, CRAWFORD, DELTA,

DICKINSON, EATON, EMMET, GLADWIN, GOGEBIC, GRAND TRAVERSE, GRATIOT, HILLSDALE, HOUGHTON, HURON, INGHAM, IONIA, IOSCO, IRON, ISABELLA, JACKSON, KALAMAZOO, KALKASKA, KENT, KEWEENAW, LAKE, LAPEER, LEELANAU, LENAWEE, LUCE, MACKINAC, MANISTEE, MARQUETTE, MASON, MECOSTA, MENOMINEE, MIDLAND, MISSAUKEE, MONTCALM, MONTMORENCY, MUSKEGON, NEWAYGO, OCEANA, OGEMAW, ONTONAGON, OSCEOLA, OSCODA, OTSEGO, OTTAWA, PRESQUE ISLE, ROSCOMMON, SANILAC, SCHOOLCRAFT, SHIAWASSEE, SAGINAW, ST. CLAIR, ST. JOSEPH, TUSCOLA, VAN BUREN AND WEXFORD COUNTIES

AREA 2: GENESEE, LIVINGSTON, MACOMB, MONROE, OAKLAND, WASHTENAW AND WAYNE COUNTIES

	Rates	Fringes
Sign Installer		
AREA 1		
GROUP 1.....	\$ 20.18	.15 + a
GROUP 2.....	\$ 19.93	.15 + a
AREA 2		
GROUP 1.....	\$ 21.73	.15 + a
GROUP 2.....	\$ 21.48	.15 + a

FOOTNOTE:

a. \$132.70 per week, plus \$17.80 per day.

SIGN INSTALLER CLASSIFICATIONS:

GROUP 1: performs all necessary labor and uses all tools required to construct and set concrete forms required in the installation of highway and street signs

GROUP 2: performs all miscellaneous labor, uses all hand and power tools, and operates all other equipment, mobile or otherwise, required for the installation of highway and street signs

TEAM0247-010 04/01/2016

AREA 1: LAPEER AND SHIAWASSEE COUNTIES

AREA 2: GENESEE, MACOMB, MONROE, OAKLAND, ST. CLAIR, WASHTENAW AND WAYNE COUNTIES

	Rates	Fringes
TRUCK DRIVER (Underground construction)		
AREA 1		
GROUP 1.....	\$ 22.82	17.885
GROUP 2.....	\$ 22.91	17.885
GROUP 3.....	\$ 23.12	17.885
AREA 2		
GROUP 1.....	\$ 23.12	17.885
GROUP 2.....	\$ 23.26	17.885
GROUP 3.....	\$ 23.00405.90/wk+59.50/day	

PAID HOLIDAYS: New Year's Day, Memorial Day, Fourth of July, Labor Day, Thanksgiving Day and Christmas Day.

SCOPE OF WORK: Excavation, site preparation, land balancing,

grading, sewers, utilities and improvements; also including but not limited to, tunnels, underground piping, retention, oxidation, flocculation facilities, conduits, general excavation and steel sheeting for underground construction. Underground construction work shall not include any structural modifications, alterations, additions and repairs to buildings or highway work, including roads, streets, bridge construction and parking lots or steel erection.

TRUCK DRIVER CLASSIFICATIONS

GROUP 1: Truck driver on all trucks (EXCEPT dump trucks of 8 cubic yards capacity or over, pole trailers, semis, low boys, Euclid, double bottom and fuel trucks)

GROUP 2: Truck driver on dump trucks of 8 cubic yards capacity or over, pole trailers, semis and fuel trucks

GROUP 3: Truck driver on low boy, Euclid and double bottom

SUMI2002-001 05/01/2002

	Rates	Fringes
Flag Person.....	\$ 10.10	0.00
LINE PROTECTOR (ZONE 1: GENESEE, MACOMB, MONROE, OAKLAND, WASHTENAW AND WAYNE)....	\$ 18.98	12.17
LINE PROTECTOR (ZONE 2: STATEWIDE (EXCLUDING GENESEE, MACOMB, MONROE, OAKLAND, WASHTENAW AND WAYNE).....	\$ 17.14	12.17
Pavement Marking Machine (ZONE 1: GENESEE, MACOMB, MONROE, OAKLAND, WASHTENAW AND WAYNE COUNTIES) Group 1.....	\$ 24.89	12.17
Pavement Marking Machine (ZONE 1: GENESEE, MACOMB, MONROE, OAKLAND, WASHTENAW AND WAYNE) Group 2.....	\$ 22.40	12.17
Pavement Marking Machine (ZONE 2: STATEWIDE (EXCLUDING GENESEE, MACOMB, MONROE, OAKLAND, WASHTENAW AND WAYNE COUNTIES) Group 1.....	\$ 22.89	12.17
Pavement Marking Machine (ZONE 2: STATEWIDE (EXCLUDING GENESEE, MACOMB, MONROE, OAKLAND, WASHTENAW AND WAYNE) Group 2.....	\$ 20.60	12.17

WORK CLASSIFICATIONS:

PAVEMENT MARKER GROUP 1: Drives or operates a truck mounted striper, grinder, blaster, groover, or thermoplastic melter

for the placement or removal of temporary or permanent pavement markings or markers.

PAVEMENT MARKER GROUP 2: Performs all functions involved for the placement or removal of temporary or permanent pavement markings or markers not covered by the classification of Pavement Marker Group 1 or Line Protector.

LINE PROTECTOR: Performs all operations for the protection or removal of temporary or permanent pavement markings or markers in a moving convoy operation not performed by the classification of Pavement Marker Group 1. A moving convoy operation is comprised of only Pavement Markers Group 1 and Line Protectors.

WELDERS - Receive rate prescribed for craft performing operation to which welding is incidental.
=====

Note: Executive Order (EO) 13706, Establishing Paid Sick Leave for Federal Contractors applies to all contracts subject to the Davis-Bacon Act for which the contract is awarded (and any solicitation was issued) on or after January 1, 2017. If this contract is covered by the EO, the contractor must provide employees with 1 hour of paid sick leave for every 30 hours they work, up to 56 hours of paid sick leave each year. Employees must be permitted to use paid sick leave for their own illness, injury or other health-related needs, including preventive care; to assist a family member (or person who is like family to the employee) who is ill, injured, or has other health-related needs, including preventive care; or for reasons resulting from, or to assist a family member (or person who is like family to the employee) who is a victim of, domestic violence, sexual assault, or stalking. Additional information on contractor requirements and worker protections under the EO is available at www.dol.gov/whd/govcontracts.

Unlisted classifications needed for work not included within the scope of the classifications listed may be added after award only as provided in the labor standards contract clauses (29CFR 5.5 (a) (1) (ii)).

The body of each wage determination lists the classification and wage rates that have been found to be prevailing for the cited type(s) of construction in the area covered by the wage determination. The classifications are listed in alphabetical order of "identifiers" that indicate whether the particular rate is a union rate (current union negotiated rate for local), a survey rate (weighted average rate) or a union average rate (weighted union average rate).

Union Rate Identifiers

A four letter classification abbreviation identifier enclosed in dotted lines beginning with characters other than "SU" or "UAVG" denotes that the union classification and rate were prevailing for that classification in the survey. Example: PLUM0198-005 07/01/2014. PLUM is an abbreviation identifier of the union which prevailed in the survey for this

classification, which in this example would be Plumbers. 0198 indicates the local union number or district council number where applicable, i.e., Plumbers Local 0198. The next number, 005 in the example, is an internal number used in processing the wage determination. 07/01/2014 is the effective date of the most current negotiated rate, which in this example is July 1, 2014.

Union prevailing wage rates are updated to reflect all rate changes in the collective bargaining agreement (CBA) governing this classification and rate.

Survey Rate Identifiers

Classifications listed under the "SU" identifier indicate that no one rate prevailed for this classification in the survey and the published rate is derived by computing a weighted average rate based on all the rates reported in the survey for that classification. As this weighted average rate includes all rates reported in the survey, it may include both union and non-union rates. Example: SULA2012-007 5/13/2014. SU indicates the rates are survey rates based on a weighted average calculation of rates and are not majority rates. LA indicates the State of Louisiana. 2012 is the year of survey on which these classifications and rates are based. The next number, 007 in the example, is an internal number used in producing the wage determination. 5/13/2014 indicates the survey completion date for the classifications and rates under that identifier.

Survey wage rates are not updated and remain in effect until a new survey is conducted.

Union Average Rate Identifiers

Classification(s) listed under the UAVG identifier indicate that no single majority rate prevailed for those classifications; however, 100% of the data reported for the classifications was union data. EXAMPLE: UAVG-OH-0010 08/29/2014. UAVG indicates that the rate is a weighted union average rate. OH indicates the state. The next number, 0010 in the example, is an internal number used in producing the wage determination. 08/29/2014 indicates the survey completion date for the classifications and rates under that identifier.

A UAVG rate will be updated once a year, usually in January of each year, to reflect a weighted average of the current negotiated/CBA rate of the union locals from which the rate is based.

WAGE DETERMINATION APPEALS PROCESS

1.) Has there been an initial decision in the matter? This can be:

- * an existing published wage determination
- * a survey underlying a wage determination
- * a Wage and Hour Division letter setting forth a position on a wage determination matter
- * a conformance (additional classification and rate) ruling

On survey related matters, initial contact, including requests for summaries of surveys, should be with the Wage and Hour

Regional Office for the area in which the survey was conducted because those Regional Offices have responsibility for the Davis-Bacon survey program. If the response from this initial contact is not satisfactory, then the process described in 2.) and 3.) should be followed.

With regard to any other matter not yet ripe for the formal process described here, initial contact should be with the Branch of Construction Wage Determinations. Write to:

Branch of Construction Wage Determinations
Wage and Hour Division
U.S. Department of Labor
200 Constitution Avenue, N.W.
Washington, DC 20210

2.) If the answer to the question in 1.) is yes, then an interested party (those affected by the action) can request review and reconsideration from the Wage and Hour Administrator (See 29 CFR Part 1.8 and 29 CFR Part 7). Write to:

Wage and Hour Administrator
U.S. Department of Labor
200 Constitution Avenue, N.W.
Washington, DC 20210

The request should be accompanied by a full statement of the interested party's position and by any information (wage payment data, project description, area practice material, etc.) that the requestor considers relevant to the issue.

3.) If the decision of the Administrator is not favorable, an interested party may appeal directly to the Administrative Review Board (formerly the Wage Appeals Board). Write to:

Administrative Review Board
U.S. Department of Labor
200 Constitution Avenue, N.W.
Washington, DC 20210

4.) All decisions by the Administrative Review Board are final.

=====
END OF GENERAL DECISION

General Decision Number: MI170074 02/03/2017 MI74

Superseded General Decision Number: MI20160074

State: Michigan

Construction Type: Heavy

County: Washtenaw County in Michigan.

Heavy, Includes Water, Sewer Lines and Excavation (Excludes Hazardous Waste Removal; Coal, Oil, Gas, Duct and other similar Pipeline Construction)

Note: Under Executive Order (EO) 13658, an hourly minimum wage of \$10.20 for calendar year 2017 applies to all contracts subject to the Davis-Bacon Act for which the contract is awarded (and any solicitation was issued) on or after January 1, 2015. If this contract is covered by the EO, the contractor must pay all workers in any classification listed on this wage determination at least \$10.20 (or the applicable wage rate listed on this wage determination, if it is higher) for all hours spent performing on the contract in calendar year 2017. The EO minimum wage rate will be adjusted annually. Additional information on contractor requirements and worker protections under the EO is available at www.dol.gov/whd/govcontracts.

Modification Number	Publication Date
0	01/06/2017
1	02/03/2017

CARP0687-006 06/01/2016

	Rates	Fringes
CARPENTER, Includes Form Work....	\$ 31.16	26.56

ELEC0252-009 06/14/2016

	Rates	Fringes
ELECTRICIAN.....	\$ 34.58	25.22

ENGI0325-019 06/01/2016

POWER EQUIPMENT OPERATORS: Underground Construction (Including Sewer)

	Rates	Fringes
POWER EQUIPMENT OPERATOR		
GROUP 1.....	\$ 31.58	22.85
GROUP 2.....	\$ 26.85	22.85
GROUP 3.....	\$ 26.12	22.85
GROUP 4.....	\$ 25.55	22.85

POWER EQUIPMENT OPERATOR CLASSIFICATIONS

GROUP 1: Backhoe/ Excavator, Boring Machine, Bulldozer, Crane, Grader/ Blade, Loader, Roller, Scraper, Trencher (over 8 ft. digging capacity)

GROUP 2: Trencher (8-ft digging capacity and smaller)

GROUP 3: Boom Truck (non-swinging, non- powered type boom)

GROUP 4: Broom/ Sweeper, Fork Truck, Tractor, Bobcat/ Skid Steer /Skid Loader

ENGI0326-008 06/01/2016

EXCLUDES UNDERGROUND CONSTRUCTION

	Rates	Fringes
OPERATOR: Power Equipment		
GROUP 1.....	\$ 39.64	22.90
GROUP 2.....	\$ 38.14	22.90
GROUP 3.....	\$ 36.64	22.90
GROUP 4.....	\$ 36.34	22.90
GROUP 5.....	\$ 35.52	22.90
GROUP 6.....	\$ 34.66	22.90
GROUP 7.....	\$ 33.69	22.90
GROUP 8.....	\$ 31.98	22.90
GROUP 9.....	\$ 23.64	22.90

FOOTNOTES: Tower cranes: to be paid the crane operator rate determined by the combined length of the mast and the boom.

POWER EQUIPMENT OPERATOR CLASSIFICATIONS

GROUP 1: Crane with boom & jib or leads 400' or longer

GROUP 2: Crane with boom & jib or leads 300' or longer

GROUP 3: Crane with boom & jib or leads 220' or longer

GROUP 4: Crane with boom & jib or leads 140' or longer

GROUP 5: Crane with boom & jib or leads 120' or longer

GROUP 6: Regular crane operator

GROUP 7: Backhoe/Excavator, Bobcat/Skid Loader, Boring Machine, Broom/Sweeper, Bulldozer, Grader/Blade, Loader, Roller, Scraper, Tractor, Trencher

GROUP 8: Forklift

GROUP 9: Oiler

IRON0025-006 06/01/2015

	Rates	Fringes
IRONWORKER		
Reinforcing.....	\$ 28.30	24.60
Structural.....	\$ 33.78	27.84

LABO0334-009 06/01/2015

EXCLUDES OPEN CUT CONSTRUCTION

	Rates	Fringes
Landscape Laborer		
GROUP 1.....	\$ 19.76	9.15

GROUP 2.....\$ 15.54

9.15

LANDSCAPE LABORER CLASSIFICATIONS

GROUP 1: Landscape specialist, including air, gas and diesel equipment operator, lawn sprinkler installer and skidsteer (or equivalent)

GROUP 2: Landscape laborer: small power tool operator, material mover, truck driver and lawn sprinkler installer tender

LABO0334-018 09/01/2014

SCOPE OF WORK:

OPEN CUT CONSTRUCTION: Excavation of earth and sewer, utilities, and improvements, including underground piping/conduit (including inspection, cleaning, restoration, and relining)

	Rates	Fringes
LABORER		
(1) Common or General.....	\$ 22.45	12.75
(2) Mason Tender- Cement/Concrete.....	\$ 22.56	12.75
(4) Grade Checker.....	\$ 22.75	12.75
(5) Pipelayer.....	\$ 22.90	12.75
(7) Landscape.....	\$ 16.84	12.75

LABO0499-020 08/01/2014

EXCLUDES OPEN CUT CONSTRUCTION

	Rates	Fringes
LABORER		
GROUP 1.....	\$ 28.32	13.85
GROUP 2.....	\$ 28.52	13.85
GROUP 3.....	\$ 28.64	13.85

LABORER CLASSIFICATIONS

GROUP 1: Common or General; Grade Checker

GROUP 2: Mason Tender - Cement/Concrete

GROUP 3: Pipelayer

PAIN0022-005 07/01/2008

	Rates	Fringes
PAINTER		
Brush & Roller.....	\$ 25.06	14.75
Spray.....	\$ 25.86	14.75

PLAS0514-002 05/01/2016

	Rates	Fringes
CEMENT MASON/CONCRETE FINISHER...	\$ 31.55	14.80

	Rates	Fringes
PLUMBER.....	\$ 38.99	21.06

* TEAM0007-006 06/01/2016

	Rates	Fringes
TRUCK DRIVER		
Dump Truck under 8 cu. yds.; Tractor Haul Truck....	\$ 24.90	.50 + a+b
Dump Truck, 8 cu. yds. and over.....	\$ 25.00	.50 + a+b
Lowboy/Semi-Trailer Truck...	\$ 25.15	.50 + a+b

FOOTNOTE:
a. \$438.45 per week.
b. \$61.90 daily.

SUMI2010-072 11/09/2010

	Rates	Fringes
TRUCK DRIVER: Off the Road Truck.....	\$ 20.82	3.69

WELDERS - Receive rate prescribed for craft performing operation to which welding is incidental.

=====
Note: Executive Order (EO) 13706, Establishing Paid Sick Leave for Federal Contractors applies to all contracts subject to the Davis-Bacon Act for which the contract is awarded (and any solicitation was issued) on or after January 1, 2017. If this contract is covered by the EO, the contractor must provide employees with 1 hour of paid sick leave for every 30 hours they work, up to 56 hours of paid sick leave each year. Employees must be permitted to use paid sick leave for their own illness, injury or other health-related needs, including preventive care; to assist a family member (or person who is like family to the employee) who is ill, injured, or has other health-related needs, including preventive care; or for reasons resulting from, or to assist a family member (or person who is like family to the employee) who is a victim of, domestic violence, sexual assault, or stalking. Additional information on contractor requirements and worker protections under the EO is available at www.dol.gov/whd/govcontracts.

Unlisted classifications needed for work not included within the scope of the classifications listed may be added after award only as provided in the labor standards contract clauses (29CFR 5.5 (a) (1) (ii)).

The body of each wage determination lists the classification and wage rates that have been found to be prevailing for the cited type(s) of construction in the area covered by the wage determination. The classifications are listed in alphabetical order of "identifiers" that indicate whether the particular

rate is a union rate (current union negotiated rate for local), a survey rate (weighted average rate) or a union average rate (weighted union average rate).

Union Rate Identifiers

A four letter classification abbreviation identifier enclosed in dotted lines beginning with characters other than "SU" or "UAVG" denotes that the union classification and rate were prevailing for that classification in the survey. Example: PLUM0198-005 07/01/2014. PLUM is an abbreviation identifier of the union which prevailed in the survey for this classification, which in this example would be Plumbers. 0198 indicates the local union number or district council number where applicable, i.e., Plumbers Local 0198. The next number, 005 in the example, is an internal number used in processing the wage determination. 07/01/2014 is the effective date of the most current negotiated rate, which in this example is July 1, 2014.

Union prevailing wage rates are updated to reflect all rate changes in the collective bargaining agreement (CBA) governing this classification and rate.

Survey Rate Identifiers

Classifications listed under the "SU" identifier indicate that no one rate prevailed for this classification in the survey and the published rate is derived by computing a weighted average rate based on all the rates reported in the survey for that classification. As this weighted average rate includes all rates reported in the survey, it may include both union and non-union rates. Example: SULA2012-007 5/13/2014. SU indicates the rates are survey rates based on a weighted average calculation of rates and are not majority rates. LA indicates the State of Louisiana. 2012 is the year of survey on which these classifications and rates are based. The next number, 007 in the example, is an internal number used in producing the wage determination. 5/13/2014 indicates the survey completion date for the classifications and rates under that identifier.

Survey wage rates are not updated and remain in effect until a new survey is conducted.

Union Average Rate Identifiers

Classification(s) listed under the UAVG identifier indicate that no single majority rate prevailed for those classifications; however, 100% of the data reported for the classifications was union data. EXAMPLE: UAVG-OH-0010 08/29/2014. UAVG indicates that the rate is a weighted union average rate. OH indicates the state. The next number, 0010 in the example, is an internal number used in producing the wage determination. 08/29/2014 indicates the survey completion date for the classifications and rates under that identifier.

A UAVG rate will be updated once a year, usually in January of each year, to reflect a weighted average of the current negotiated/CBA rate of the union locals from which the rate is based.

1.) Has there been an initial decision in the matter? This can be:

- * an existing published wage determination
- * a survey underlying a wage determination
- * a Wage and Hour Division letter setting forth a position on a wage determination matter
- * a conformance (additional classification and rate) ruling

On survey related matters, initial contact, including requests for summaries of surveys, should be with the Wage and Hour Regional Office for the area in which the survey was conducted because those Regional Offices have responsibility for the Davis-Bacon survey program. If the response from this initial contact is not satisfactory, then the process described in 2.) and 3.) should be followed.

With regard to any other matter not yet ripe for the formal process described here, initial contact should be with the Branch of Construction Wage Determinations. Write to:

Branch of Construction Wage Determinations
Wage and Hour Division
U.S. Department of Labor
200 Constitution Avenue, N.W.
Washington, DC 20210

2.) If the answer to the question in 1.) is yes, then an interested party (those affected by the action) can request review and reconsideration from the Wage and Hour Administrator (See 29 CFR Part 1.8 and 29 CFR Part 7). Write to:

Wage and Hour Administrator
U.S. Department of Labor
200 Constitution Avenue, N.W.
Washington, DC 20210

The request should be accompanied by a full statement of the interested party's position and by any information (wage payment data, project description, area practice material, etc.) that the requestor considers relevant to the issue.

3.) If the decision of the Administrator is not favorable, an interested party may appeal directly to the Administrative Review Board (formerly the Wage Appeals Board). Write to:

Administrative Review Board
U.S. Department of Labor
200 Constitution Avenue, N.W.
Washington, DC 20210

4.) All decisions by the Administrative Review Board are final.

=====
END OF GENERAL DECISION

**DETAILED SPECIFICATION
FOR
STORM SEWER**

1 of 2

DESCRIPTION

This work shall consist of constructing storm sewer in accordance with section 402 of the 2012 MDOT Standard Specifications for Construction, and as modified herein.

MATERIALS

The sewer pipe shall meet the requirements of the City of Ann Arbor Standard Specifications.

Trench backfill shall be Class II sand in accordance with the Detailed Specification for Sand and Aggregate contained herein.

Connections between new and existing pipe and/or structures shall be by "Fernco" type joint fasteners/couplings, or other methods approved by the Engineer,

CONSTRUCTION METHODS

The Contractor shall install storm sewer in accordance with section 402 of the 2012 MDOT Standard Specifications for Construction, and per the appropriate Trench Detail contained within these Contract Documents.

The Contractor shall remove and properly dispose of all excavated materials, removed storm sewer and debris, and shall bulkhead or abandon existing pipe and structures, all as directed by the Engineer.

The Contractor shall maintain line and grade of the sewer by means of a laser. The Engineer will establish line and grade for the sewer construction and will provide cut sheets for the Contractor's use.

In areas where the road is to be reconstructed, the Contractor may elect to perform sewer work prior to the removal of pavement and subgrade preparation. In such cases, the work associated with pavement removal, excavation, backfill, and the temporary patching of the trench as necessary for traffic maintenance, will not be paid for separately, but shall be included in these items of work.

At the completion of installation, and prior to acceptance, the Contractor shall clean all new storm sewer and structures and televise the pipe.

MEASUREMENT AND PAYMENT

Where the contractor elects to furnish and place flowable fill as backfill for these items, it will not be paid separately, but shall be included in the bid prices for these items of work.

The completed work as measured for these items of work will be paid for at the Contract Unit Price for the following Contract (Pay) Items:

**DETAILED SPECIFICATION
FOR
STORM SEWER**

2 of 2

PAY ITEM

Sewer, CI C 76 IV, ___ inch, Tr Det ___, Modified

PAY UNIT

Foot

The unit prices for these items of work shall include all labor, material, and equipment costs to perform all the work specified in the Standard Specifications and as modified by this Detailed Specification.

**SPECIAL PROVISION
FOR
DRAINAGE STRUCTURES**

AA:JN

1 of 3

5/4/17

a. Description.- This work shall consist of constructing drainage structures in accordance with Section 403 of the Michigan Department of Transportation 2012 Standard Specifications for Construction, as shown on the plans, and as specified herein.

b. Materials.- The materials used for this work shall conform to Subsection 403.02 of the Michigan Department of Transportation 2012 Standard Specifications for Construction, except as specified herein.

Storm sewer drainage structures shall be constructed of precast or cast-in-place reinforced concrete sections, or concrete masonry units. All sanitary sewer manholes and gate wells (water main valve manholes) shall be constructed of precast reinforced concrete sections.

Precast reinforced concrete bases, bottom sections, manhole risers, grade adjustment rings, concentric cones, eccentric cones, and flat slab tops shall conform to the requirements of ASTM C-478. Joints on precast manholes used on all sanitary sewers shall meet ASTM C-443, rubber O-ring gasket.

If precast structures are used, the Contractor shall field verify inverts prior to fabricating precast units. No additional payment will be made to the Contractor for precast units that cannot be used due to existing inverts being different than shown on the plans, changes in vertical or horizontal alignment due to conditions found in the field, or similar unforeseen circumstances. Precast structures shall be constructed such that they are capable of being temporarily lowered to permit grading and paving.

If the Contractor elects to use precast drainage structures, or if portions of the drainage structures are constructed with precast concrete elements, the Contractor shall submit to the Engineer for review and approval shop drawings in accordance with Section 104.02 of the Michigan Department of Transportation 2012 Standard Specifications for Construction.

For each submittal or resubmittal, the Contractor shall allow at least 14 calendar days from the date of the submittal to receive the Engineer's acceptance or request for revisions. The Engineer's comments shall be incorporated into the submitted plans, calculations and descriptions. The Engineer's acceptance is required before beginning the work. Resubmittals shall be reviewed and returned to the General Contractor within 14 calendar days. Required revisions will not be a basis of payment for additional compensation, extra work, or an extension of contract time. The Contractor shall include time for this entire review process in his/her CPM network schedule.

Concrete masonry units shall conform to the requirements for concrete masonry units for catch basins and manholes, ASTM C-139.

Concrete brick shall conform to the requirements for concrete building brick, ASTM C-55, Grade N-1.

Plastic coated manhole steps shall be injection molded of copolymer, polypropylene, encapsulating a 1/2 inch grade 60 steel reinforcing bar. Plastic-coated manhole steps shall meet

SPECIAL PROVISION
FOR
DRAINAGE STRUCTURES

AA:JN

2 of 3

5/4/17

the performance test described in ASTM C-478, Paragraph II, and shall have an impact resistance of 300 ft.-lbs. with only minor deflection and no cracking or breaking. The steps shall resist pull out forces of 1500 lbs.

MDOT 6A aggregate for leaching inlets shall conform to section 902 of the 2012 MDOT Standard Specifications for Construction.

c. Methods of Construction.- The construction methods used shall conform to Section 403.03 of the Michigan Department of Transportation 2012 Standard Specifications for Construction except as specified herein.

Excavation shall be carried to the depth and width required to permit the construction of the required base. The excavation width shall be greater than the base. The bottom of the excavation shall be trimmed to a uniform horizontal bed and be completely dewatered before any concrete is placed therein. Precast manhole bases and precast bottom sections are allowed.

Concrete block construction shall only be allowed for storm sewer manholes and inlets and shall be built of the size and dimensions shown on the Plans. The block shall be clean, laid in a full bed of mortar, and thoroughly bonded by completely filling the vertical end grooves with mortar so as to interlock with the adjacent block. The mortar beds and joints shall not exceed 3/4 inch thickness. The vertical joints are to be completely filled with the joints on the inside face rubbed full of mortar and struck smooth as the manhole, inlet or structure is built up. The entire outside face of the structure shall receive a 1/2 inch thick mortar coat and struck smooth. All masonry materials, sand, and water shall be heated to over 50° F during freezing weather, and the completed work shall be covered and protected from damage by freezing.

Circular precast manhole sections shall be constructed in accordance with the details as shown on the plans. Manhole stack units shall be constructed on level poured-in-place bases, precast concrete bases, or precast concrete bottom sections.

Precast cone sections shall be constructed in accordance with the details as shown on the plans. These units shall be eccentric for all manholes, precast or block. All structures shall be topped with a minimum of one, and a maximum of three, 2 inch tall, brick or precast adjustment courses.

Manholes, inlets, gate wells and structures shall be constructed within 2-1/2 inches of plumb.

Frames and cover castings shall be set in full mortar beds and pointed on the structure interior to a smooth, brushed finish. The covers shall be set flush with sidewalk, roadway pavement, or ground surfaces. The Engineer shall be notified prior to the final paving so as to allow inspection of the final casting adjustments for all utility structures. In gravel streets, covers shall be set six to eight inches below finished gravel surface.

Sewer pipes shall extend into structures a minimum of 1/2 inch and a maximum of 3 inches.

**SPECIAL PROVISION
FOR
DRAINAGE STRUCTURES**

AA:JN

3 of 3

5/4/17

Flow channels for sewer structures shall be finished in accordance with the details as shown on the plans. All flow channels shall be screeded and floated to a smooth, uniform surface and troweled to a hard surface finish.

Stubs for future sewer connections shall be furnished and placed by the Contractor as shown on the Plans and as directed by the Engineer. Connections shall be properly supported and braced when not resting on original ground so that any settlement will not disturb the connection. Stubs shall consist of one length of sewer pipe, of the size indicated on the Plans, with a watertight plug.

All necessary adjustments for new structures shall be included in the cost of the structure.

d. Measurement and Payment.- The completed work as measured shall be paid at the contract unit price for the following contract items (pay items):

<u>(Contract Item) Pay Item</u>	<u>Pay Unit</u>
Dr Structure, ___ inch dia	Each
Dr Structure, ___ inch dia, Add Depth	Foot
Dr Structure, Type III, ___ inch dia	Each

Payment for drainage structures includes furnishing the labor, equipment and materials for all necessary excavation, disposing of surplus excavated material, backfilling, and constructing the structure complete, including pipe connections and structure cleaning. A standard depth manhole shall be considered to be 10 feet or less in depth (including sump).

Payment for additional depth for drainage structures includes furnishing the labor, equipment, and materials for all necessary excavation, disposing of surplus excavated material, backfilling, and constructing the structure complete, including pipe connections and structure cleaning, for the portion of the structure which is deeper than 10 feet (including sump).

In addition to the above, payment for Dr Structure, Manhole, Type III, ___ inch dia, shall include all labor, equipment, and materials required to construct a shallow manhole with a flat slab top to the elevations as detailed on the plans.

Payment for adjusting of drainage structure covers shall be included in payment for the structure. Drainage structure covers will be paid for separately.

**DETAILED SPECIFICATION
FOR
STORM WATER TREATMENT STRUCTURE**

AA:JN

1 OF 2

4/11/17

DESCRIPTION

This work shall include the complete installation of a storm water treatment structure, as shown on the Plans, and as directed by the Engineer.

MATERIALS

The 3" vortex flow control valve shall be self-activated by utilizing the upstream hydraulic head. The unit shall consist of an intake, a volute and an outlet and shall be installed into the precast weir wall as shown on the Plans.

The vortex flow control valve shall be capable of limiting the discharge flow from the over-sized storm sewer to less than 0.5 cfs throughout the range of upstream head conditions of 0 to 5.5 feet.

The unit shall be constructed of 304 stainless steel and shall include a pivoting bypass door to allow maintenance should plugging occur.

The manhole and weir wall shall be precast structures and shall conform to the SPECIAL PROVISION FOR DRAINAGE STRUCTURES, contained elsewhere in these contract documents, except that they shall be designed to accommodate HL-93 Modified Live Load requirements as determined by a Professional Engineer licensed by the State of Michigan, regardless of where they are to be installed. For the purposes of design, a HL-93 Modified Live Load shall consist of 1.2 times the design truck or 1.2 times a single 60 kip load, whichever produces the greater stresses. Submit Shop Drawings that include all dimensions, reinforcement sizes and locations, material strengths, and noting any work to be done by others at point of installation.

Submit structural calculations by a Structural Engineer registered in the State of Michigan to Owner's Engineer for review upon request. Engineer review shall not relieve the Contractor of the design responsibility.

Polyurethane elastomeric sealant and primer shall be from the same manufacturer and specifically designed to be compatible. Sealant and primer shall be suitable for moist installation environment, vertical installation, and totally submerged service conditions. Sealant shall meet requirements for ASTM C920, Type S, Grade NS, Class 35, using T, NT, O, M, G, I. The material shall be Sikaflex-1A and Sikaflex Primer 429, or approved equal.

Butyl rubber based preformed flexible sealant conforming to ASTM C-990, paragraph 6.2. The material shall be PRO-STIK, EZ-STIK or approved equal.

CONSTRUCTION METHODS

Construction of the manhole structure shall comply with all requirements and standards of the City of Ann Arbor Standard Specifications for Type II manholes and the Special Provision for Drainage Structures.

Seal between base slab and bottom of precast riser with 3/4" diameter butyl preformed flexible sealant.

**DETAILED SPECIFICATION
FOR
STORM WATER TREATMENT STRUCTURE**

AA:JN

2 OF 2

4/11/17

Prime and seal the vertical joints on each side of the flow control wall and precast manhole wall with polyurethane elastomeric sealer and compatible primer. Apply primer and sealant in accordance with manufacturer's instructions. Allow seven days for sealant to cure before allowing to be submerged in water.

The vortex flow control valve unit shall be installed in the precast structure weir wall using an appropriately sized sleeve and o-ring gaskets.

MEASUREMENT AND PAYMENT

All work will be paid for at the Contract unit price for the following:

PAY ITEM

PAY UNIT

Stormwater Control Structure, 84 inch dia

Each

Payment includes furnishing the labor, equipment and materials for all necessary excavation; disposal of surplus excavated material; backfill and compaction; construction of the structure complete, including concrete base, pipe connections, precast structure sections or concrete block, precast weir wall, flow channels, steps, concrete bricks, mortar, adjustment to finish grade, and structure cleaning; and installation of the vortex flow control valve unit.

DETAILED SPECIFICATION
FOR
CONCRETE SIDEWALKS, SIDEWALK RAMPS, AND DRIVEWAY APPROACHES

AA:JN

1 of 2

5/4/17

a. Description. This work shall consist of constructing concrete sidewalks, sidewalk ramps, or driveway approaches of the types as indicated on the plans in accordance with attached details, and as directed by the Engineer. All sidewalks and ramps shall contain fibermesh reinforcement. All work shall be in accordance with sections 801 and 803 of the Michigan Department of Transportation (MDOT) 2012 Standard Specifications for Construction, and as specified herein.

b. Materials. The materials shall meet the requirements as specified sections 801 and 803 of the MDOT 2012 Standard Specifications for Construction and as required herein. The concrete mixture shall be Grade P-NC as specified in section 601 of the MDOT 2012 Standard Specifications. The concrete mixture for ramps and drive approaches shall be High Early concrete containing 8.4 sacks of cement.

Fibermesh reinforcement shall consist of polypropylene fibrillated fibers added at the rate of 1.5 pounds per cubic yard to the concrete. The fibers shall meet the requirements of ASTM C1116-89 "Specification for Fiber Reinforced Concrete and Shotcrete" Classification 4.1.3 Type III. The concrete shall be thoroughly mixed for a minimum of 5 minutes after the addition of the fibers to assure uniform distribution throughout the concrete.

All concrete mixtures shall contain 6AA coarse aggregates which are either natural or limestone and meet the requirements of section 902 of the MDOT 2012 Standard Specifications for Construction.

It shall be the Contractor's sole responsibility to propose specific concrete mix designs which meet the requirements of this Detailed Specification.

c. Construction Methods. The Contractor is responsible to construct all sidewalks, sidewalk ramps, curbs, and all other concrete items within ADAAG compliance. All sidewalk and curb ramps must be constructed in accordance with the current MDOT Standard Plan Series R-28.

The Contractor shall trim and compact granular material as needed to construct new concrete items and to relocate existing concrete items to their new elevations and locations.

Where concrete is to be placed, it shall be placed on a minimum of 4 inches of Granular Material Class II compacted to 95% of its maximum dry density. In the downtown area, all sidewalk shall be placed on a minimum of 6 inches of Granular Material Class II, and all sidewalk ramps and drive approaches shall be placed on a minimum of 8 inches of Granular Material Class II, all of which is compacted to 95% of its maximum dry density.

Where indicated on the plans, the Contractor shall horizontally sawcut curbs to provide openings for sidewalk ramps. The Engineer shall define the extent of sawcutting both horizontally and vertically. This work will not be paid for separately, but shall be included in the corresponding price of the ADA ramp to be placed.

All sidewalk ramps shall be installed with detectable warning units. Reference the Detailed Specification entitled "Detectable Warning Surface" for additional requirements.

d. Measurement and Payment. The completed work, as described, will be measured and paid for at the contract unit prices respectively for the following pay items:

<u>Pay Item</u>	<u>Pay Unit</u>
Sidewalk, Concrete, ___ inch, Modified	Square Foot
Sidewalk Ramp, Approach, Concrete, ___ inch, Modified.....	Square Foot

The above items will be measured by area in square feet and be paid for at their respective contract unit price, which price shall be payment in full for all labor, equipment and material needed to accomplish this work.

The unit price for "Sidewalk Ramp, Approach, Concrete, ___ inch, Modified" shall also include all costs associated with sawcutting curbs to provide openings for sidewalk ramps as indicated on the plans.

The furnishing and adding the fibermesh reinforcement materials shall also be included in the contract unit price for the respective sidewalk and ramp pay items.

Detectable warning units shall be paid for in accordance with the Detailed Specification for Detectable Warning Surface.

CITY OF ANN ARBOR
SPECIAL PROVISION
FOR
TEMPORARY WATER MAIN LINE STOP

AA:JN

1 of 5

5/4/17

a. Description.- The Contractor shall furnish all materials, labor and equipment to properly install and set water main line stops into the existing ductile iron main(s) at the locations as shown on the plans and as directed by the Engineer. All work shall be performed in accordance with the requirements as detailed herein.

The existing mains, upstream and downstream of the proposed line stop(s) cannot be shut down or taken out of service. To ensure that the entire operation shall be accomplished without interruption of service or flow, the installation shall be accomplished by Contractor personnel skilled and experienced in the procedures specific to line stops of the required size(s).

b. Materials.- Bedding and backfill for areas contained within a segment of water main designated as Trench Detail I (under roadbed), Modified, shall be Granular Material, Class II, meeting the requirements of Section 902. For work within a segment of water main designated as Trench Detail V (outside of the 1:1 influence line of roadbed or curb and gutter), Modified, Granular Material, Class II and Engineer approved native material, placed in accordance with the trench details, shall be used.

The Contractor shall submit to the Engineer two (2) sets of drawings, furnished by manufacturers, illustrating and describing the Line Stop fittings proposed to be furnished. Work shall not commence until such time as the drawings have been reviewed and accepted by the Engineer.

Line Stop Fittings shall be full encirclement, pressure retention type split tee. It shall consist of two steel weldments; an upper line stop flange saddle plate and a lower saddle plate. These two saddle plates shall be contiguous.

Line Stop Flange: The outlet of each fitting shall be machined from a 150 lb. forged steel flange (ASTM A181 or A105) or from pressure vessel quality steel plate (ASTM A285, Grade C); flat faced and drilled per ANSI B16.5). Suitable independently operated locking devices shall be provided in the periphery of the flange to secure the completion plug.

Line stop Nozzle: The nozzle, which lies between the saddle and the flange shall be fabricated from steel pipe (ASTM A234). After welding and stress relief, the nozzle shall be accurately bored as follows to accommodate the Line stop plugging head:

- a) Machine an internal circular shoulder to seal against the circumferential gasket carried on the plugging head.

Completion Plug: The completion plug shall be machined from a stress relieved carbon steel weldment. It shall contain two (2) circumferential grooves: one to receive the locking devices from the Line stop flange, and the second to contain a compressible "O" ring to seal pressure tight against the bore of the flange.

Blind Flange: Each Line stop fitting shall be closed with a blind flange. Facing and drilling of the

CITY OF ANN ARBOR
SPECIAL PROVISION
FOR
TEMPORARY WATER MAIN LINE STOP

AA:JN

2 of 5

5/4/17

blind flange shall be compatible with that of the Line stop flange. Minimum blind flange thickness shall be that of AWWA Spec. 207, Class D.

Saddle Alignment Marking: Each saddle-half shall be matched and marked with serial numbers, to insure proper alignment in the field.

Fasteners: All bolts, studs, and nuts used on Line stop, drain/equalization fittings, blind flange, and other elements that shall remain upon completion of the work shall be stainless steel and meet the requirements of ASTM F 593.

General: Manufacturer will exercise extreme care to insure that weldments are of adequate strength, properly shaped, securely reinforced, and free from distortion that could stress the ductile iron main during installation, pressure tapping, or Line stopping operations. All steel shall meet the requirements of ASTM A36, as a minimum. All weldments shall be braced and stress relieved.

Gaskets: Shall be molded from elastomer compounds that resist compression setting and are compatible with water in the 32 to 140 deg. F temperature range.

Upper Line stop Flange Saddle: Shall consist of a saddle plate, a Line stop flange, and a Line Stop nozzle. The interior of the saddle plate, adjacent to and concentric with the O.D. of the nozzle, shall be grooved to retain a gasket which shall seal the saddle plate to the exterior of the ductile iron main. This gasket shall constitute the only seal between the main and the fitting. The flange saddle shall also meet the following requirements:

- a) Saddle plate shall be of a minimum of 0.375" in thickness. It shall be shaped to be concentric to the outside of the ductile iron main. The smallest I.D. of the saddle and its interior rings shall exceed the O.D. of the main by a minimum of 0.250" to allow for ovality of the main;
- b) Line stop nozzle of 0.375" min. wall thickness shall be securely welded to the saddle plate;
- c) The Line Stop flange shall be securely welded to the nozzle. After welding, the assembly shall be braced, stress relieved, and bored to receive the completion plug and the circumferential gasket of the Line Stop machine plugging head; and,
- d) Bolt, nut of stud, nut, and washer assemblies shall be furnished to draw the upper and lower saddles together for sealing. Bolting brackets shall be gusseted.

Lower Saddle Plate: Saddle plate shall be of a minimum 0.375" thickness and shall be shaped to be concentric to the outside brackets shall match upper half.

c. Equipment.- The equipment shall consist of a cylindrical plugging head that contains a flat, expandable elastomer sealing element. The plugging head shall be advanced into and retracted from the main by means of a linear actuator. When retracted, the plugging head and carrier are housed in an adapter, bolted pressure tight between the tapping valve and the actuator.

CITY OF ANN ARBOR
SPECIAL PROVISION
FOR
TEMPORARY WATER MAIN LINE STOP

AA:JN

3 of 5

5/4/17

Sealing Element: The element shall be monolithically molded from a suitable polyurethane compound. The element shall be flat in a plane perpendicular to the flow in the main. Minimum thickness of the element shall be 4". The bottom of the element shall be semi-circular to conform to the bore of the main.

Drilling equipment: Shall be in good working condition, equipped with power drive to insure smooth cutting, and to minimize shock and vibration. Cutting equipment shall be carbide tipped and capable of being replaced without removal from the jobsite.

Plugging Head: The diameter of the cylindrical plugging head shall be slightly smaller than the bore of the Line Stop nozzle. The plugging head shall have a suitable circumferential gasket to seal against the shoulder in the Line stop nozzle. This gasket shall also seal against the sealing element to prevent bypass flow around the Line stop.

Deposits in Bore of Main: The semi-cylindrical bottom of the plugging head shall be designed to break and dislodge tuberculation and other deposits in the bore of the main which might interfere with a satisfactory Line stop.

d. Method of Construction.- Installation of proposed line stops mains will require work in close proximity to existing utilities. This must be taken into consideration when the contractor determines the required trench safety requirements. All excavation shall conform to MIOSHA Standards; the Contractor is solely responsible for determining all excavation and trench safety requirements.

If necessary, The City will reduce the pressure to 100 psig or less for the duration of the installations. The entire operation of installing the line stop shall be accomplished without reduction of water pressure in the main(s) below 100 psig. It shall be the responsibility of the Contractor to verify pressure prior to commencing the installation.

Preliminary Field Inspection of Water Main:

Dimensional, specification, and other data regarding the existing mains have been taken from existing records. This information may be inaccurate, out of date, and/or inadequate.

The data have not been verified by field inspections. Further, the water main consists of ductile iron pipe which may contain dimensional and structural flaws. In addition, the Contractor shall anticipate that exterior main conditions, bells, service connections, or presence of adjoining utilities may require relocation of proposed line stop. Prior to proceeding with the installation of any line stop, it is necessary to know the exact main outside diameter of the water main, if it has any ovality, and the internal diameter of the pipe before line stop fittings and plugging head sealing elements can be manufactured and/or ordered.

Prior to ordering material, Contractor shall excavate at each proposed location and carefully measure the outside diameter of the water main with calipers along at least four (4) locations to determine ovality and the critical outside diameter of the water main. The

CITY OF ANN ARBOR
SPECIAL PROVISION
FOR
TEMPORARY WATER MAIN LINE STOP

AA:JN

4 of 5

5/4/17

Contractor shall determine main wall thickness, uniformity, and structural integrity by means of ultrasonic testing. Data shall be taken to determine extent of internal deposits, tuberculation, etc..

If the Engineer determines that Contractor's data are not adequate, the Engineer may direct Contractor to make one or more pressure taps on main to obtain test pipe coupons for the Engineer's evaluation. The minimum size of the test coupon shall be 5" diameter, drilled through a nominal 6" valve. Pressure tapping saddles and other materials used for inspection taps shall conform to the requirements of this Special Provision. The Contractor shall anticipate that heavy interior corrosion and/or tuberculation exists within the water main.

If, in Engineer's opinion, the proposed location is unsatisfactory based on measurements of the existing pipe at the locations of the proposed line stops, the Engineer will direct excavation at another site. Excavating, de-watering, inspections, backfill, and restoration will be paid for separately in accordance with the applicable contract unit prices or Section 109.05.C and 109.05.D whichever the Engineer deems most appropriate.

Because of possible internal corrosion and deposits in existing water mains, a "bottle-tight" shut down may not occur. A satisfactory shutdown which allows the work to be accomplished (i.e. valve replacement, water main tie-in, etc.) using drainage pumps to de-water excavations, with workmen wearing boots and raingear, if necessary, must be obtained. The Contractor will not be allowed to proceed with further work until an acceptable shutdown is achieved. The Contractor shall be aware that this may require the halting of work and re-scheduling of all work operations.

Contractor shall power wire brush and grind the exterior of the water main to remove any debris, corrosion deposits, or other surface irregularities that might interfere with proper seating and sealing of each line stop fitting against each main. Any structural defects in the water main, service connections, appurtenances, adjacent utilities, etc., that could interfere with the line stop installation shall be immediately reported to Engineer.

All line stop fittings and appurtenances shall be cleaned and disinfected in accordance with the current City of Ann Arbor Public Services Area Standard Specifications prior to bolting any of the line stop fittings in place or commencing any pipe cutting.

Contractor shall fit upper and lower saddle plate assemblies to main, thoroughly checking for proper fit to main. Under no circumstances shall Contractor attempt to force, reshape, or bend saddle plates by excessive tightening of saddle studs while the line stop fitting is assembled around the main. Any required retrofitting shall be accomplished with the fitting removed from the main. Any damage to fitting, accessories, or main shall be repaired at Contractor's expense to the satisfaction of Engineer.

Upper and Lower saddle halves shall be drawn together by bolt assemblies and the Saddle plates shall be bolted together in the horizontal position.

CITY OF ANN ARBOR
SPECIAL PROVISION
FOR
TEMPORARY WATER MAIN LINE STOP

AA:JN

5 of 5

5/4/17

All line stop work shall be performed in accordance with the equipment manufacturers approved work procedures and installation guidelines.

Final closure of the water main shall be accomplished by insertion of a manufacturer-approved completion plug. The Contractor shall test the completion plug sealing through the use of a bleed off assembly in the machine housing.

The Contractor shall remove the temporary valve and the installation of a blind flange shall be completed.

The Contractor shall place polyethylene encasement meeting the requirements of the City of Ann Arbor Standard Specifications for Construction around the upper and lower saddle halves, the blind flange, and to a point at least 1 foot on either side of the saddle halves. All polyethylene encasement shall be securely taped to the water main such that water entry is minimized to the greatest extent possible.

e. Measurement and Payment.- The completed work will be paid for at the contract unit prices for the following contract items (pay items):

<u>Contract Item (Pay Item)</u>	<u>Pay Unit</u>
Water Main Line Stop ___ inch to ___ inch.....	Each

All work shall be paid in full at the contract unit prices which shall include all the labor, materials, and equipment required to perform the work as detailed herein. This shall also include all required costs associated with night time work, supplemental lighting, and all other required elements of the work.

The work shall include, but not be limited to; pavement sawcutting; excavation and disposal of excavated material; the furnishing, installation, and removal of sheeting and/or shoring where needed; the furnishing, placement and compaction of approved bedding and backfill materials; the furnishing, placement and compaction of cold patch or temporary HMA, as directed by the Engineer, to restore the pavement surface after the initial exposure to verify pipe size and upon completion of line stop installation; furnishing and placing suitable, clean, gravel to create a stable working surface at the bottom of the excavation; dewatering; pipe cleaning, measuring, and performing all advance work necessary to prepare for the performance of the line stop; nighttime lighting as required; the removal of all materials and equipment associated with the work when no longer needed; and, any other items needed to complete the work as detailed on the plans and as specified herein.