

# **PUBLIC IMPROVEMENT REQUEST FOR PROPOSAL**

**RFP# 24-23**

## **Barton/Bandemer Park Pedestrian Tunnel Project**

City of Ann Arbor  
PARKS AND RECREATION SERVICES/COMMUNITY  
SERVICES AREA



**Due Date: May 8, 2024 by 11:00a.m.(local time)**

Issued By:

City of Ann Arbor  
Procurement Unit  
301 E. Huron Street  
Ann Arbor, MI 48104

TABLE OF CONTENTS

SECTION I: GENERAL INFORMATION .....3

SECTION II: SCOPE OF WORK..... 11

SECTION III: MINIMUM INFORMATION REQUIRED ..... 12

SECTION IV: ATTACHMENTS ..... 22

## **SECTION I - GENERAL INFORMATION**

### **A. OBJECTIVE**

The purpose of this Request for Proposal (RFP) is to select a firm to provide construction services for the Barton/Bandemer Park Pedestrian Tunnel Project.

### **B. BID SECURITY**

Each bid must be accompanied by a certified check or Bid Bond by a surety licensed and authorized to do business within the State of Michigan, in the amount of 5% of the total of the bid price.

***Proposals that fail to provide a bid security upon proposal opening will be deemed non-responsive and will not be considered for award.***

### **C. QUESTIONS AND CLARIFICATIONS / DESIGNATED CITY CONTACTS**

All questions regarding this Request for Proposal (RFP) shall be submitted via e-mail. Questions will be accepted and answered in accordance with the terms and conditions of this RFP.

**All questions shall be submitted on or before April 26, 2024 at 2:00 p.m. (local time)**, and should be addressed as follows:

Scope of Work/Proposal Content questions shall be e-mailed to Hillary Hanzel, Park Planner – [hhanzel@a2gov.org](mailto:hhanzel@a2gov.org) and Jeremy Hedden, Project Manager for CED – [jeremy.hedden@collierseng.com](mailto:jeremy.hedden@collierseng.com).

RFP Process and Compliance questions shall be e-mailed to Colin Spencer, Buyer - [CSpencer@a2gov.org](mailto:CSpencer@a2gov.org)

Should any prospective bidder be in doubt as to the true meaning of any portion of this RFP, or should the prospective bidder find any ambiguity, inconsistency, or omission therein, the prospective bidder shall make a written request for an official interpretation or correction by the due date for questions above.

All interpretations, corrections, or additions to this RFP will be made only as an official addendum that will be posted to [a2gov.org](http://a2gov.org) and [MITN.info](http://MITN.info) and it shall be the prospective bidder's responsibility to ensure they have received all addenda before submitting a proposal. Any addendum issued by the City shall become part of the RFP, and must be incorporated in the proposal where applicable.

#### **D. PRE-PROPOSAL MEETING**

A pre-proposal conference for this project will be held on **April 23, 2024 at 10:00 a.m. (local time)** at the Bandemer Park Parking Lot, 2001 Whitmore Lake Road, Ann Arbor, MI 48105.

Attendance at this conference is highly recommended. Administrative and technical questions regarding this project will be answered at this time. The pre-proposal conference is for information only. Any answers furnished will not be official until verified in writing by the Financial Service Area, Procurement Unit. Answers that change or substantially clarify the proposal will be affirmed in an addendum.

#### **E. PROPOSAL FORMAT**

To be considered, each firm must submit a response to this RFP using the format provided in Section III. No other distribution of proposals is to be made by the prospective bidder. An official authorized to bind the bidder to its provisions must sign the proposal. Each proposal must remain valid for at least one hundred and twenty (120) days from the due date of this RFP.

Proposals should be prepared simply and economically providing a straightforward, concise description of the bidder's ability to meet the requirements of the RFP. No erasures are permitted. Mistakes may be crossed out and corrected and must be initialed in ink by the person signing the proposal.

#### **F. SELECTION CRITERIA**

Responses to this RFP will be evaluated using a point system as shown in Section III. A selection committee comprised primarily of staff from the City will complete the evaluation.

If interviews are desired by the City, the selected firms will be given the opportunity to discuss their proposal, qualifications, past experience, and their fee proposal in more detail. The City further reserves the right to interview the key personnel assigned by the selected bidder to this project.

All proposals submitted may be subject to clarifications and further negotiation. All agreements resulting from negotiations that differ from what is represented within the RFP or in the proposal response shall be documented and included as part of the final contract.

#### **G. SEALED PROPOSAL SUBMISSION**

**All proposals are due and must be delivered to the City on or before May 8, 2024 11:00 a.m. (local time).** Proposals submitted late or via oral, telephonic, telegraphic, electronic mail or facsimile **will not** be considered or accepted.

**Each respondent should submit in a sealed envelope**

- **one (1) original proposal**
- **one (2) additional proposal copy**
- **one (1) digital copy of the proposal preferably on a USB/flash drive as one file in PDF format**

Proposals submitted should be clearly marked: “**RFP No. 24-23 – Barton/Bandemer Park Pedestrian Tunnel Project**” and list the bidder’s name and address.

Proposals must be addressed and delivered to:

City of Ann Arbor  
c/o Customer Service  
301 East Huron Street  
Ann Arbor, MI 48107

All proposals received on or before the due date will be publicly opened and recorded on the due date. No immediate decisions will be rendered.

Hand delivered proposals may be dropped off in the Purchasing drop box located in the Ann Street (north) vestibule/entrance of City Hall which is open to the public Monday through Friday from 8am to 5pm (except holidays). The City will not be liable to any prospective bidder for any unforeseen circumstances, delivery, or postal delays. Postmarking on the due date will not substitute for receipt of the proposal.

Bidders are responsible for submission of their proposal. Additional time will not be granted to a single prospective bidder. However, additional time may be granted to all prospective bidders at the discretion of the City.

**A proposal may be disqualified if the following required forms are not included with the proposal:**

- **Attachment B – General Declarations**
- **Attachment D - Prevailing Wage Declaration of Compliance**
- **Attachment E - Living Wage Declaration of Compliance**
- **Attachment G - Vendor Conflict of Interest Disclosure Form**
- **Attachment H - Non-Discrimination Declaration of Compliance**

***Proposals that fail to provide these forms listed above upon proposal opening may be deemed non-responsive and may not be considered for award.***

## **H. DISCLOSURES**

Under the Freedom of Information Act (Public Act 442), the City is obligated to permit review of its files, if requested by others. All information in a proposal is subject to

disclosure under this provision. This act also provides for a complete disclosure of contracts and attachments thereto.

## **I. TYPE OF CONTRACT**

A sample of the Construction Agreement is included as Attachment A. Those who wish to submit a proposal to the City are required to review this sample agreement carefully. **The City will not entertain changes to its Construction Agreement.**

For all construction work, the respondent must further adhere to the City of Ann Arbor General Conditions. The General Conditions are included herein. Retainage will be held as necessary based on individual tasks and not on the total contract value. The Contractor shall provide the required bonds included in the Contract Documents for the duration of the Contract.

The City reserves the right to award the total proposal, to reject any or all proposals in whole or in part, and to waive any informality or technical defects if, in the City's sole judgment, the best interests of the City will be so served.

This RFP and the selected bidder's response thereto, shall constitute the basis of the scope of services in the contract by reference.

## **J. NONDISCRIMINATION**

All bidders proposing to do business with the City shall satisfy the contract compliance administrative policy adopted by the City Administrator in accordance with the Section 9:158 of the Ann Arbor City Code. Breach of the obligation not to discriminate as outlined in Attachment G shall be a material breach of the contract. Contractors are required to post a copy of Ann Arbor's Non-Discrimination Ordinance attached at all work locations where its employees provide services under a contract with the City.

## **K. WAGE REQUIREMENTS**

The Attachments provided herein outline the requirements for payment of prevailing wages or of a "living wage" to employees providing service to the City under this contract. The successful bidder must comply with all applicable requirements and provide documentary proof of compliance when requested.

Pursuant to Resolution R-16-469 all public improvement contractors are subject to prevailing wage and will be required to provide to the City payroll records sufficient to demonstrate compliance with the prevailing wage requirements. Use of Michigan Department of Transportation Prevailing Wage Forms (sample attached hereto) or a City-approved equivalent will be required along with wage rate interviews.

For laborers whose wage level are subject to federal, state and/or local prevailing wage law the appropriate Davis-Bacon wage rate classification is identified based

upon the work including within this contract. **The wage determination(s) current on the date 10 days before proposals are due shall apply to this contract.** The U.S. Department of Labor (DOL) has provided explanations to assist with classification in the following resource link: [www.wdol.gov](http://www.wdol.gov).

For the purposes of this RFP the Construction Type of Highway will apply.

#### **L. CONFLICT OF INTEREST DISCLOSURE**

The City of Ann Arbor Purchasing Policy requires that the consultant complete a Conflict of Interest Disclosure form. A contract may not be awarded to the selected bidder unless and until the Procurement Unit and the City Administrator have reviewed the Disclosure form and determined that no conflict exists under applicable federal, state, or local law or administrative regulation. Not every relationship or situation disclosed on the Disclosure Form may be a disqualifying conflict. Depending on applicable law and regulations, some contracts may awarded on the recommendation of the City Administrator after full disclosure, where such action is allowed by law, if demonstrated competitive pricing exists and/or it is determined the award is in the best interest of the City. A copy of the Conflict of Interest Disclosure Form is attached.

#### **M. COST LIABILITY**

The City of Ann Arbor assumes no responsibility or liability for costs incurred by the bidder prior to the execution of an Agreement. The liability of the City is limited to the terms and conditions outlined in the Agreement. By submitting a proposal, bidder agrees to bear all costs incurred or related to the preparation, submission, and selection process for the proposal.

#### **N. DEBARMENT**

Submission of a proposal in response to this RFP is certification that the Respondent is not currently debarred, suspended, proposed for debarment, and declared ineligible or voluntarily excluded from participation in this transaction by any State or Federal departments or agency. Submission is also agreement that the City will be notified of any changes in this status.

#### **O. PROPOSAL PROTEST**

All proposal protests must be in writing and filed with the Purchasing Manager within five (5) business days of any notices of intent, including, but not exclusively, divisions on prequalification of bidders, shortlisting of bidders, or a notice of intent to award. Only bidders who responded to the solicitation may file a bid protest. The bidder must clearly state the reasons for the protest. If any bidder contacts a City Service Area/Unit and indicates a desire to protest an award, the Service Area/Unit shall refer the bidder to the Purchasing Manager. The Purchasing Manager will provide the bidder with the

appropriate instructions for filing the protest. The protest shall be reviewed by the City Administrator or designee, whose decision shall be final.

Any inquiries or requests regarding this procurement should be only submitted in writing to the Designated City Contacts provided herein. Attempts by the bidder to initiate contact with anyone other than the Designated City Contacts provided herein that the bidder believes can influence the procurement decision, e.g., Elected Officials, City Administrator, Selection Committee Members, Appointed Committee Members, etc., may lead to immediate elimination from further consideration.

**P. SCHEDULE**

The following is the schedule for this RFP process.

<b>Activity/Event</b>	<b>Anticipated Date</b>
Pre-Proposal Conference	April 23, 2024, 10:00 a.m. (Local Time)
Written Question Deadline	April 26, 2024, 2:00 p.m. (Local Time)
Addenda Published (if needed)	Week of April 29, 2024
Proposal Due Date	May 8, 2024, 11:00 a.m. (Local Time)
Selection/Negotiations	May/June 2024
Expected City Council Authorizations	July 2024

The above schedule is for information purposes only and is subject to change at the City’s discretion.

**Q. IRS FORM W-9**

The selected bidder will be required to provide the City of Ann Arbor an IRS form W-9.

**R. RESERVATION OF RIGHTS**

1. The City reserves the right in its sole and absolute discretion to accept or reject any or all proposals, or alternative proposals, in whole or in part, with or without cause.
2. The City reserves the right to waive, or not waive, informalities or irregularities in terms or conditions of any proposal if determined by the City to be in its best interest.
3. The City reserves the right to request additional information from any or all bidders.
4. The City reserves the right to reject any proposal that it determines to be unresponsive and deficient in any of the information requested within RFP.
5. The City reserves the right to determine whether the scope of the project will be entirely as described in the RFP, a portion of the scope, or a revised scope be implemented.
6. The City reserves the right to select one or more contractors or service providers to perform services.



7. The City reserves the right to retain all proposals submitted and to use any ideas in a proposal regardless of whether that proposal is selected. Submission of a proposal indicates acceptance by the firm of the conditions contained in this RFP, unless clearly and specifically noted in the proposal submitted.
8. The City reserves the right to disqualify proposals that fail to respond to any requirements outlined in the RFP, or failure to enclose copies of the required documents outlined within the RFP.

## **S. IDLEFREE ORDINANCE**

The City of Ann Arbor adopted an idling reduction Ordinance that went into effect July 1, 2017. The full text of the ordinance (including exemptions) can be found at: [www.a2gov.org/idlefree](http://www.a2gov.org/idlefree).

Under the ordinance, No Operator of a Commercial Vehicle shall cause or permit the Commercial Vehicle to Idle:

- (a) For any period of time while the Commercial Vehicle is unoccupied; or
- (b) For more than 5 minutes in any 60-minute period while the Commercial Vehicle is occupied.

In addition, generators and other internal combustion engines are covered

- (1) Excluding Motor Vehicle engines, no internal combustion engine shall be operated except when it is providing power or electrical energy to equipment or a tool that is actively in use.

## **T. ENVIRONMENTAL COMMITMENT**

The City of Ann Arbor recognizes its responsibility to minimize negative impacts on human health and the environment while supporting a vibrant community and economy. The City further recognizes that the products and services the City buys have inherent environmental and economic impacts and that the City should make procurement decisions that embody, promote, and encourage the City's commitment to the environment.

The City encourages potential vendors to bring forward emerging and progressive products and services that are best suited to the City's environmental principles.

## **U. MAJOR SUBCONTRACTORS**

The Bidder shall identify each major subcontractor it expects to engage for this Contract if the work to be subcontracted is 15% or more of the bid sum or over \$50,000, whichever is less. The Bidder also shall identify the work to be subcontracted to each major subcontractor. The Bidder shall not change or replace a subcontractor without approval by the City.

## **N. LIQUIDATED DAMAGES**

A liquidated damages clause, as given on page C-2 and in the Detailed Specifications, Article III of the Contract, provides that the Contractor shall pay the City as liquidated damages, and not as a penalty, a sum certain per day for each and every day that the Contractor may be in default of completion of the specified work, within the time(s) stated in the Contract, or written extensions.

Liquidated damages clauses, as given in the General Conditions, provide further that the City shall be entitled to impose and recover liquidated damages for breach of the obligations under Chapter 112 of the City Code.

The liquidated damages are for the non-quantifiable aspects of any of the previously identified events and do not cover actual damages that can be shown or quantified nor are they intended to preclude recovery of actual damages in addition to the recovery of liquidated damages.

## **SECTION II - SCOPE OF WORK**

Project includes the construction of 800-feet of concrete shared use path and a new pedestrian underpass below the Michigan Line RR along the Border-to-Border Trail connecting Bandemer Park and the Barton Nature Area along Huron River Drive.

**Please see the plan set for more details.**

### **A. Standard Specifications**

All work performed under this Contract shall be performed in accordance with the Public Services Department Standard Specifications in effect at the date of availability of the contract documents stipulated in the Advertisement. All work under this Contract which is not included in these Standard Specifications, or which is performed using modifications to these Standard Specifications, shall be performed in accordance with the Detailed Specifications provided during the implementation of individual tasks under this Contract.

The selected Contractor will be required to comply with all Amtrak (National Railroad Passenger Corporation) and MDOT Office of Rail requirements relating to the Contractor's role in the project on behalf of the City which may include being a party to a Construction Phase Agreement with Amtrak, signing an indemnification certificate with Amtrak, submitting and obtaining a permit to enter, agreeing to indemnify those entities, meeting specific insurance requirements (e.g. providing Builders Risk Insurance if required for the Project by Amtrak and/or MDOT Office of Rail ) and providing proof thereof, or other requirements.

Copies of the Standard Specifications can be downloaded from the following web link.

<https://www.a2gov.org/departments/engineering/Pages/Engineering-and-Contractor-Resources.aspx>

## **SECTION III - MINIMUM INFORMATION REQUIRED**

### **PROPOSAL FORMAT**

The following describes the elements that should be included in each of the proposal sections and the weighted point system that will be used for evaluation of the proposals.

Bidders should organize Proposals into the following Sections:

- A. Qualifications, Experience and Accountability
- B. Workplace Safety
- C. Workforce Development
- D. Social Equity and Sustainability
- E. Schedule of Pricing/Cost
- F. Authorized Negotiator
- G. Attachments

*Bidders are strongly encouraged to provide details for all of the information requested below within initial proposals. Backup documentation may be requested at the sole discretion of the City to validate all of the responses provided herein by bidders. False statements by bidders to any of the criteria provided herein will result in the proposal being considered non-responsive and will not be considered for award.*

Pursuant to Sec 1:325 of the City Code which sets forth requirements for evaluating public improvement bids, Bidders should submit the following:

#### **A. Qualifications, Experience and Accountability - 20 Points**

1. Qualifications and experience of the bidder and of key persons, management, and supervisory personnel to be assigned by the bidder.
2. References from individuals or entities the bidder has worked for within the last five (5) years including information regarding records of performance and job site cooperation.
3. Evidence of any quality control program used by the bidder and the results of any such program on the bidder's previous projects.
4. A statement from the bidder as to any major subcontractors it expects to engage including the name, work, and amount.

**B. Workplace Safety – 20 Points**

1. Provide a copy of the bidder's safety program, and evidence of a safety-training program for employees addressing potential hazards of the proposed job site. Bidder must identify a designated qualified safety representative responsible for bidder's safety program who serves as a contact for safety related matters.
2. Provide the bidder's Experience Modification Rating ("EMR") for the last three consecutive years. Preference within this criterion will be given to an EMR of 1.0 or less based on a three-year average.
3. Evidence that all craft labor that will be employed by the bidder for the project has, or will have prior to project commencement, completed at least an authorized 10-hour OSHA Construction Safety Course.
4. For the last three years provide a copy of any documented violations and the bidder's corrective actions as a result of inspections conducted by the Michigan Occupational Safety & Health Administration (MIOSHA), U.S. Department of Labor – Occupational Safety and Health Administration (OSHA), or any other applicable safety agency.

**C. Workforce Development – 20 Points**

1. Documentation as to bidder's pay rates, health insurance, pension or other retirement benefits, paid leave, or other fringe benefits to its employees.
- 2.. Documentation that the bidder participates in a Registered Apprenticeship Program that is registered with the United States Department of Labor Office of Apprenticeship or by a State Apprenticeship Agency recognized by the USDOL Office of Apprenticeship. USDOL apprenticeship agreements shall be disclosed to the City in the solicitation response.
3. Bidders shall disclose the number of non-craft employees who will work on the project on a 1099 basis, and the bidders shall be awarded points based on their relative reliance on 1099 work arrangements with more points assigned to companies with fewer 1099 arrangements. Bidders will acknowledge that the City may ask them to produce payroll records at points during the project to verify compliance with this section.

**D. Social Equity and Sustainability – 20 Points**

1. A statement from the bidder as to what percentage of its workforce resides in the City of Ann Arbor and in Washtenaw County, Michigan. The City will consider in

evaluating which bids best serve its interests, the extent to which responsible and qualified bidders employ individuals in either the city or the county. Washtenaw County jurisdiction is prioritized for evaluation purposes for this solicitation.

2. Evidence of Equal Employment Opportunity Programs for minorities, women, veterans, returning citizens, and small businesses.
3. Evidence that the bidder is an equal opportunity employer and does not discriminate on the basis of race, sex, pregnancy, age, religion, national origin, marital status, sexual orientation, gender identity or expression, height, weight, or disability.
4. The bidder's proposed use of sustainable products, technologies, or practices for the project, which reduce the impact on human health and the environment, including raw materials acquisition, production, manufacturing, packaging, distribution, reuse, operation, maintenance, and waste management.
5. The bidder's environmental record, including findings of violations and penalties imposed by government agencies.

**E. Schedule of Pricing/Cost – 20 Points**

Company: \_\_\_\_\_

**Unit Price Bid –**

<u>Item Description</u>	<u>Estimated Quantity</u>	<u>Unit Price</u>	<u>Total Price</u>
Certified Payroll Compliance and Reporting	1	LSUM	_____
Mobilization, Max	1	LSUM	_____
Clearing, Modified	0.25	Acre	_____
Tree, Rem, 19 inch to 36 inch	6	Ea	_____
Tree, Rem, 37 inch or Larger	2	Ea	_____
Tree, Rem, 6 inch to 18 inch	10	Ea	_____
Fence, Rem	101	Ft	_____
Exploratory Investigation, Vertical	150	Ft	_____
Embankment, CIP	15	Cyd	_____
Excavation, Earth	2360	Cyd	_____
Non Haz Contaminated Material Handling and Disposal, LM	5800	Cyd	_____
Subgrade Undercutting, Type I	100	Cyd	_____
Subgrade Undercutting, Type II	100	Cyd	_____
Subgrade Undercutting, Type IV	100	Cyd	_____
Backfill, Structure, CIP	5050	Cyd	_____
Excavation, Fdn	5830	Cyd	_____
Aggregate, 6A	16	Cyd	_____
Dewatering System, Excavation	1	LSUM	_____
Erosion Control, Filter Bag	2	Ea	_____
Erosion Control, Gravel Access Approach	2	Ea	_____
Erosion Control, Inlet Protection, Fabric Drop	5	Ea	_____
Erosion Control, Silt Fence	1739	Ft	_____
Subbase, CIP	3	Cyd	_____
Aggregate Base, 8 inch, Modified	365	Syd	_____
Maintenance Gravel	100	Ton	_____
Geotextile, Separator, Non-Woven	245	Syd	_____
Culv End Sect, Conc, 12 inch	3	Ea	_____
Sewer, CI E, 12 inch, Tr Det B	95	Ft	_____

Slotted Drain, Galv, 6 inch	42	Ft		
Sewer, PVC, 6 inch, Tr Det B	187	Ft		
Dr Structure Cover, Type C	1	Ea		
Dr Structure, 24 inch dia	1	Ea		
Clean Out	3	Ea		
Underdrain, Fdn, 6 inch	324	Ft		
Culv Bedding, Box Culv	81	Cyd		
Culv, Precast Conc Box, 16 foot by 12 foot	60	Ft		
HMA Surface, Rem	215	Syd		
Hand Patching	16	Ton		
HMA, 4EML	33	Ton		
HMA, 5EML	33	Ton		
Joint, Expansion, E3	39	Ft		
Steel Sheet Piling, Permanent	3015	Sft		
Steel Sheet Piling, Temp, Left in Place, Special	1450	Sft		
Steel Sheet Piling, Temp, Special	500	Sft		
Elec Grounding System	1	Ea		
Reinforcement, Steel, Epoxy Coated	2831	Lb		
Substructure Conc, High Performance	39	Cyd		
Liner, PVC, 30 mil	415	Syd		
Timber Bridge	1	LSUM		
Joint Waterproofing	160	Sft		
Modular Block Wall, Cap	254	Ft		
Modular Block Wall	1028	Sft		
Railroad Protection, Amtrak	20000	Dlr		
Curb, Conc, Det E1	735	Ft		
Curb and Gutter, Conc, Det D2	207	Ft		
Detectable Warning Surface	13	Ft		
Sidewalk, Conc, 4 inch	157	Sft		
Shared use Path, Grading, Modified	739	Ft		
Shared use Path, Aggregate, 8 inch, Modified	1591	Syd		
Shared use Path, Concrete, 6 inch	953	Syd		
Shared use Path, Concrete, 6 inch, Decorative	148	Syd		
Shared use Path, Aggregate, Tunnel	66	Cyd		



Fence, Protective	1000	Ft		
Fence, Rustic Split Rail	404	Ft		
Ornamental Aluminum Fence, 72 inch	152	Ft		
Fence Gate, 12 foot, for 72 inch Chain Link Fence, Special	14	Ft		
Fence, Chain Link, 72 Inch, Special	206	Ft		
Ornamental Aluminum Fence, 48 inch	124	Ft		
Fence, Protective, Special	800	Sft		
Post, Steel, 3 pound	166	Ft		
Sign, Type IIIB	2	Sft		
Pavt Mrkg, Polyurea, 4 inch, Yellow	278	Ft		
Pavt Mrkg, Polyurea, 12 inch, Cross Hatching, Yellow	270	Ft		
Pavt Mrkg, Preformed Thermopl, Accessible Sym	1	Ea		
Pavt Mrkg, Waterborne, for Rest Areas, Parks, and Lots, 4 inch, Blue	75	Ft		
Barricade, Type III, High Intensity, Double Sided, Lighted, Furn	10	Ea		
Barricade, Type III, High Intensity, Double Sided, Lighted, Oper	10	Ea		
Pedestrian Type II Barricade, Temp	10	Ea		
Pedestrian Type II Channelizer, Temp	50	Ft		
Lighted Arrow, Type C, Furn	2	Ea		
Lighted Arrow, Type C, Oper	2	Ea		
Ltg for Night Work	1	LSUM		
Minor Traf Devices	1	LSUM		
Plastic Drum, Fluorescent, Furn	35	Ea		
Plastic Drum, Fluorescent, Oper	35	Ea		
Sign Cover	5	Ea		
Sign, Type B, Temp, Prismatic, Furn	316	Sft		
Sign, Type B, Temp, Prismatic, Oper	316	Sft		
Sign, Type B, Temp, Prismatic, Spec, Furn	96	Sft		
Sign, Type B, Temp, Prismatic, Spec, Oper	96	Sft		
Traf Regulator Control	1	LSUM		
Check Dam, Cobblestone	20	Ft		

Riprap, Cobblestone	21	Syd		
Site Preparation, Max	1	LSUM		
Watering and Cultivating, First Season, Min	1	LSUM		
Watering and Cultivating, 2nd Season, Min	1	LSUM		
Aronia melanocarpa, #5 cont.	10	Ea		
Hamamelis virginiana, #5 cont.	10	Ea		
Viburnum acerifolium, #5 cont.	5	Ea		
Viburnum lentago, #5 cont.	10	Ea		
Platanus occidentalis, 3 inch	5	Ea		
Tilia americana, 3 inch	5	Ea		
Acer saccharum 'Bailsta' FALL FIESTA, 3 inch	5	Ea		
Nyssa sylvatica, 3 inch	3	Ea		
Quercus bicolor, 3 inch	3	Ea		
Cercis canadensis, 2 1/2 inch, multi-stem	8	Ea		
Cornus florida, 2 1/2 inch	8	Ea		
Amelanchier x grandiflora 'Autumn Brilliance', 8 foot	6	Ea		
Cephalanthus occidentalis, #5 cont.	5	Ea		
Cornus stolonifera 'Farrow', #5 cont.	30	Ea		
Lindera benzoin, #5 cont.	10	Ea		
Calamagrostis x acutiflora 'Karl Foerster', #3 cont.	15	Ea		
Panicum virgatum 'Shenandoah', #3 cont.	15	Ea		
Schizachyrium scoparium, #3 cont.	15	Ea		
Live Staking	250	Syd		
Turf Establishment, Turf Grass, Performance	734	Syd		
Turf Establishment, Native Seed Mix, Mesic Woodland Mix, Performance	6404	Syd		
Conduit, Schedule 40, 2 inch	800	Ft		
Cable, Equipment Grounding Wire, 1/C#8	600	Ft		
Hh, Round, 3 foot dia	2	Ea		
Conduit, Schedule 80, 1-1/4"	600	Ft		
Cable, 600V, 1, 3/C#2	600	Ft		

Conduit, PVC, 3/4"	1350	Ft	_____	_____
Cable, 600V, 1, 3/C#12	1350	Ft	_____	_____
Cable, Grounding Wire, 1/C#12	1350	Ft	_____	_____
13"x24" Pull Box	2	Ea	_____	_____
Lighting Control Panel	1	Ea	_____	_____
Luminaire, Wall Mount, Type A	2	Ea	_____	_____
Luminaire, Linear, Type B	28	Ea	_____	_____
Luminaire, Linear, Type C	28	Ea	_____	_____
Luminaire, Pole Mount, Type D	13	Ea	_____	_____
Light Pole Foundation	13	Ea	_____	_____
Light Pole, Type D Pole	13	Ea	_____	_____
Electrical Utility Service	20000	Dir	_____	_____
Gate Valve and Box, 6 inch	1	Ea	_____	_____
Contractor Staking	1	LSUM	_____	_____
Railroad Track Monitoring	1	LSUM	_____	_____
Utility Work, Amtrak	1	LSUM	_____	_____
Utility Work, Lumen	1	LSUM	_____	_____
Limestone Cap	100	Ft	_____	_____
Limestone Block	210	Sft	_____	_____
Split Field Stone	520	Sft	_____	_____
Limestone Sign, "Bandemer"	1	Ea	_____	_____
Limestone Sign, "Barton"	1	Ea	_____	_____
Limestone Sign, "2024"	2	Ea	_____	_____
Decorative Panel, Install	1	LSUM	_____	_____
Dewatering System for Contaminated Groundwater, Site	100000	Dir	_____	_____
Decorative Panel, Furn	100000	Dir	_____	_____

**ESTIMATED TOTAL**

**\$ \_\_\_\_\_**

**F. AUTHORIZED NEGOTIATOR / NEGOTIATIBLE ELEMENTS (ALTERNATES)**

Include the name, phone number, and e-mail address of persons(s) in your organization authorized to negotiate the agreement with the City.

The proposal price shall include materials and equipment selected from the designated items and manufacturers listed in the bidding documents. This is done to establish uniformity in bidding and to establish standards of quality for the items named.

If the bidder wishes to quote alternate items for consideration by the City, it may do so under this Section. A complete description of the item and the proposed price differential must be provided. Unless approved at the time of award, substitutions where items are specifically named will be considered only as a negotiated change in Contract Sum.

If the Bidder takes exception to the time stipulated in Article III of the Contract, Time of Completion, page C-2, it is requested to stipulate its proposed time for performance of the work.

Consideration for any proposed alternative items or time may be negotiated at the discretion of the City.

**G. ATTACHMENTS**

General Declaration, Legal Status of Bidder, Conflict of Interest Form, Living Wage Compliance Form, Prevailing Wage Compliance Form and the Non-Discrimination Form should be completed and returned with the proposal. These elements should be included as attachments to the proposal submission.

**PROPOSAL EVALUATION**

1. The selection committee will evaluate each proposal by the above-described criteria and point system. The City reserves the right to reject any proposal that it determines to be unresponsive and deficient in any of the information requested for evaluation. A proposal with all the requested information does not guarantee the proposing firm to be a candidate for an interview if interviews are selected to be held by the City. The committee may contact references to verify material submitted by the bidder.
2. The committee then will schedule interviews with the selected firms if necessary. The selected firms will be given the opportunity to discuss in more detail their qualifications, past experience, proposed work plan (if applicable) and pricing.
3. The interview should include the project team members expected to work on the project, but no more than six members total. The interview shall consist of a

presentation of up to thirty minutes (or the length provided by the committee) by the bidder, including the person who will be the project manager on this contract, followed by approximately thirty minutes of questions and answers. Audiovisual aids may be used during the oral interviews. The committee may record the oral interviews.

4. The firms interviewed will then be re-evaluated by the above criteria and adjustments to scoring will be made as appropriate. After evaluation of the proposals, further negotiation with the selected firm may be pursued leading to the award of a contract by City Council, if suitable proposals are received.

The City reserves the right to waive the interview process and evaluate the bidder based on their proposal and pricing schedules alone.

The City will determine whether the final scope of the project to be negotiated will be entirely as described in this RFP, a portion of the scope, or a revised scope.

Work to be done under this contract is generally described through the detailed specifications and must be completed fully in accordance with the contract documents.

Any proposal that does not conform fully to these instructions may be rejected.

## **PREPARATION OF PROPOSALS**

Proposals should have no plastic bindings but will not be rejected as non-responsive for being bound. Staples or binder clips are acceptable. Proposals should be printed double sided on recycled paper.

Each person signing the proposal certifies that they are a person in the bidder's firm/organization responsible for the decisions regarding the fees being offered in the Proposal and has not and will not participate in any action contrary to the terms of this provision.

## **ADDENDA**

If it becomes necessary to revise any part of the RFP, notice of the addendum will be posted to Michigan Inter-governmental Trade Network (MITN) [www.mitn.info](http://www.mitn.info) and/or the City of Ann Arbor web site [www.A2gov.org](http://www.A2gov.org) for all parties to download.

Each bidder should acknowledge in its proposal all addenda it has received on the General Declarations form provided in the Attachments section herein. The failure of a bidder to receive or acknowledge receipt of any addenda shall not relieve the bidder of the responsibility for complying with the terms thereof. The City will not be bound by oral responses to inquiries or written responses other than official written addenda.

## **SECTION IV - ATTACHMENTS**

Attachment A – Sample Standard Contract

Attachment B – General Declarations

Attachment C - Legal Status of Bidder

Attachment D – Prevailing Wage Declaration of Compliance Form

Attachment E – Living Wage Declaration of Compliance Form

Attachment F – Living Wage Ordinance Poster

Attachment G – Vendor Conflict of Interest Disclosure Form

Attachment H – Non-Discrimination Ordinance Declaration of Compliance Form

Attachment I – Non-Discrimination Ordinance Poster

Sample Certified Payroll Report Template

**ATTACHMENT A  
SAMPLE STANDARD CONTRACT**

*If a contract is awarded, the selected contractor will be required to adhere to a set of general contract provisions which will become a part of any formal agreement. These provisions are general principles which apply to all contractors of service to the City of Ann Arbor such as the following:*

**Administrative Use Only**  
Contract Date: \_\_\_\_\_

**CONTRACT**

THIS CONTRACT is between the CITY OF ANN ARBOR, a Michigan Municipal Corporation, 301 East Huron Street, Ann Arbor, Michigan 48104 ("City") and \_\_\_\_\_  
\_\_\_\_\_  
("Contractor")

\_\_\_\_\_  
(An individual/partnership/corporation, include state of incorporation) (Address)

Based upon the mutual promises below, the Contractor and the City agree as follows:

**ARTICLE I - Scope of Work**

The Contractor agrees to furnish all of the materials, equipment and labor necessary; and to abide by all the duties and responsibilities applicable to it for the project titled **Barton/Bandemer Park Pedestrian Tunnel Project RFP #24-23** in accordance with the requirements and provisions of the following documents, including all written modifications incorporated into any of the documents, all of which are incorporated as part of this Contract:

- |  |                         |
|--|-------------------------|
| Non-discrimination and Living Wage Declaration of Compliance Forms (if applicable) | General Conditions      |
| Vendor Conflict of Interest Form   | Standard Specifications |
| Prevailing Wage Declaration of Compliance Form (if applicable)                     | Detailed Specifications |
| Bid Forms  | Plans                   |
| Contract and Exhibits  | Addenda                 |
| Bonds  |                         |

**ARTICLE II - Definitions**

**Administering Service Area/Unit** means **Community Services Area / Parks and Recreation Services / Community Services Area**

**Project** means **Barton/Bandemer Park Pedestrian Tunnel Project RFP #24-23**

**Supervising Professional** means the person acting under the authorization of the manager of the Administering Service Area/Unit. At the time this Contract is executed, the Supervising Professional is: **Hillary Hanzel** whose job title is **Landscape Architect IV**. If there is any question concerning who the Supervising Professional is, Contractor shall confirm with the manager of the Administering Service Area/Unit.

**Contractor's Representative** means \_\_\_\_\_ **[Insert name]** whose job title is **[Insert job title]**.

**ARTICLE III - Time of Completion**

- (A) The work to be completed under this Contract shall begin immediately on the date specified in the Notice to Proceed issued by the City.
- (B) The entire work for this Contract shall be completed in accordance with the timeline shown in the **Progress Clause**.
- (C) Failure to complete all the work within the time specified above, including any extension granted in writing by the Supervising Professional, shall obligate the Contractor to pay the City, as liquidated damages and not as a penalty, an amount equal to \$1,000 for each calendar day of delay in the completion of all the work. In addition to these, the Contractor shall pay to the City, as liquidated damages and not as a penalty, an amount equal to the schedule included in the Special Provision for **Liquidated Damages for other Department Costs**. If any liquidated damages are unpaid by the Contractor, the City shall be entitled to deduct these unpaid liquidated damages from the monies due the Contractor.

The liquidated damages are for the non-quantifiable aspects of any of the previously identified events and do not cover actual damages that can be shown or quantified nor are they intended to preclude recovery of actual damages in addition to the recovery of liquidated damages.

**ARTICLE IV - The Contract Sum**

- (A) The City shall pay to the Contractor for the performance of the Contract, the unit prices as given in the Bid Form for the estimated bid total of:

\_\_\_\_\_ Dollars (\$\_\_\_\_\_)

- (B) The amount paid shall be equitably adjusted to cover changes in the work ordered by the Supervising Professional but not required by the Contract Documents. Increases or decreases shall be determined only by written agreement between the City and Contractor.

**ARTICLE V - Assignment**



This Contract may not be assigned or subcontracted any portion of any right or obligation under this contract without the written consent of the City. Notwithstanding any consent by the City to any assignment, Contractor shall at all times remain bound to all warranties, certifications, indemnifications, promises and performances, however described, as are required of it under this contract unless specifically released from the requirement, in writing, by the City.

#### **ARTICLE VI - Choice of Law**

This Contract shall be construed, governed, and enforced in accordance with the laws of the State of Michigan. By executing this Contract, the Contractor and the City agree to venue in a court of appropriate jurisdiction sitting within Washtenaw County for purposes of any action arising under this Contract. The parties stipulate that the venue referenced in this Contract is for convenience and waive any claim of non-convenience.

Whenever possible, each provision of the Contract will be interpreted in a manner as to be effective and valid under applicable law. The prohibition or invalidity, under applicable law, of any provision will not invalidate the remainder of the Contract.

#### **ARTICLE VII - Relationship of the Parties**

The parties of the Contract agree that it is not a Contract of employment but is a Contract to accomplish a specific result. Contractor is an independent Contractor performing services for the City. Nothing contained in this Contract shall be deemed to constitute any other relationship between the City and the Contractor.

Contractor certifies that it has no personal or financial interest in the project other than the compensation it is to receive under the Contract. Contractor certifies that it is not, and shall not become, overdue or in default to the City for any Contract, debt, or any other obligation to the City including real or personal property taxes. City shall have the right to set off any such debt against compensation awarded for services under this Contract.

#### **ARTICLE VIII - Notice**

All notices given under this Contract shall be in writing, and shall be by personal delivery or by certified mail with return receipt requested to the parties at their respective addresses as specified in the Contract Documents or other address the Contractor may specify in writing. Notice will be deemed given on the date when one of the following first occur: (1) the date of actual receipt; or (2) three days after mailing certified U.S. mail.

#### **ARTICLE IX - Indemnification**

To the fullest extent permitted by law, Contractor shall indemnify, defend and hold the City, its officers, employees and agents harmless from all suits, claims, judgments and expenses including attorney's fees resulting or alleged to result, in whole or in part, from any act or omission, which is in any way connected or associated with this Contract, by the Contractor or anyone acting on the Contractor's behalf under this Contract. Contractor shall not be responsible to indemnify the City for losses or damages caused by or resulting from the City's sole negligence. The provisions of this Article shall survive the expiration or earlier termination of this contract for any reason.

#### **ARTICLE X - Entire Agreement**

This Contract represents the entire understanding between the City and the Contractor and it supersedes all prior representations, negotiations, agreements, or understandings whether written or oral. Neither party has relied on any prior representations in entering into this Contract. No terms or conditions of either party's invoice, purchase order or other administrative document shall modify the terms and conditions of this Contract, regardless of the other party's failure to object to such form. This Contract shall be binding on and shall inure to the benefit of the parties to this Contract and their permitted successors and permitted assigns and nothing in this Contract, express or implied, is intended to or shall confer on any other person or entity any legal or equitable right, benefit, or remedy of any nature whatsoever under or by reason of this Contract. This Contract may be altered, amended or modified only by written amendment signed by the City and the Contractor.

**ARTICLE XI – Electronic Transactions**

The City and Contractor agree that signatures on this Contract may be delivered electronically in lieu of an original signature and agree to treat electronic signatures as original signatures that bind them to this Contract. This Contract may be executed and delivered by facsimile and upon such delivery, the facsimile signature will be deemed to have the same effect as if the original signature had been delivered to the other party.

**FOR CONTRACTOR**

By \_\_\_\_\_

Its: \_\_\_\_\_

**FOR THE CITY OF ANN ARBOR**

By \_\_\_\_\_  
Christopher Taylor, Mayor

By \_\_\_\_\_  
Jacqueline Beaudry, City Clerk

**Approved as to substance**

By \_\_\_\_\_  
City Administrator

By \_\_\_\_\_  
Services Area Administrator

**Approved as to form and content**

\_\_\_\_\_  
Atleen Kaur, City Attorney

**PERFORMANCE BOND**

- (1) \_\_\_\_\_ (referred to as "Principal"), and \_\_\_\_\_, a corporation duly authorized to do business in the State of Michigan (referred to as "Surety"), are bound to the City of Ann Arbor, Michigan (referred to as "City"), for \$ \_\_\_\_\_, the payment of which Principal and Surety bind themselves, their heirs, executors, administrators, successors and assigns, jointly and severally, by this bond.
- (2) The Principal has entered a written Contract with the City Barton/Bandemer Park Pedestrian Tunnel Project, for RFP No. 24-23 and this bond is given for that Contract in compliance with Act No. 213 of the Michigan Public Acts of 1963, as amended, being MCL 129.201 et seq.
- (3) Whenever the Principal is declared by the City to be in default under the Contract, the Surety may promptly remedy the default or shall promptly:
- (a) complete the Contract in accordance with its terms and conditions; or
- (b) obtain a bid or bids for submission to the City for completing the Contract in accordance with its terms and conditions, and upon determination by Surety of the lowest responsible bidder, arrange for a Contract between such bidder and the City, and make available, as work progresses, sufficient funds to pay the cost of completion less the balance of the Contract price; but not exceeding, including other costs and damages for which Surety may be liable hereunder, the amount set forth in paragraph 1.
- (4) Surety shall have no obligation to the City if the Principal fully and promptly performs under the Contract.
- (5) Surety agrees that no change, extension of time, alteration or addition to the terms of the Contract or to the work to be performed thereunder, or the specifications accompanying it shall in any way affect its obligations on this bond, and waives notice of any such change, extension of time, alteration or addition to the terms of the Contract or to the work, or to the specifications.
- (6) Principal, Surety, and the City agree that signatures on this bond may be delivered electronically in lieu of an original signature and agree to treat electronic signatures as original signatures that bind them to this bond. This bond may be executed and delivered by facsimile and upon such delivery, the facsimile signature will be deemed to have the same effect as if the original signature had been delivered to the other party.

**SIGNED AND SEALED** this \_\_\_\_\_ day of \_\_\_\_\_, 202\_.

\_\_\_\_\_  
(Name of Surety Company)  
By \_\_\_\_\_  
(Signature)

Its \_\_\_\_\_  
(Title of Office)

Approved as to form:  
\_\_\_\_\_  
Atleen Kaur, City Attorney

\_\_\_\_\_  
(Name of Principal)  
By \_\_\_\_\_  
(Signature)

Its \_\_\_\_\_  
(Title of Office)

Name and address of agent:  
\_\_\_\_\_  
\_\_\_\_\_  
\_\_\_\_\_

LABOR AND MATERIAL BOND

- (1) \_\_\_\_\_ of \_\_\_\_\_ (referred to as "Principal"), and \_\_\_\_\_, a corporation duly authorized to do business in the State of Michigan, (referred to as "Surety"), are bound to the City of Ann Arbor, Michigan (referred to as "City"), for the use and benefit of claimants as defined in Act 213 of Michigan Public Acts of 1963, as amended, being MCL 129.201 et seq., in the amount of \$ \_\_\_\_\_, for the payment of which Principal and Surety bind themselves, their heirs, executors, administrators, successors and assigns, jointly and severally, by this bond.
- (2) The Principal has entered a written Contract with the City entitled Barton/Bandemer Park Pedestrian Tunnel Project for RFP No. 24-23; and this bond is given for that Contract in compliance with Act No. 213 of the Michigan Public Acts of 1963 as amended;
- (3) If the Principal fails to promptly and fully repay claimants for labor and material reasonably required under the Contract, the Surety shall pay those claimants.
- (4) Surety's obligations shall not exceed the amount stated in paragraph 1, and Surety shall have no obligation if the Principal promptly and fully pays the claimants.
- (5) Principal, Surety, and the City agree that signatures on this bond may be delivered electronically in lieu of an original signature and agree to treat electronic signatures as original signatures that bind them to this bond. This bond may be executed and delivered by facsimile and upon such delivery, the facsimile signature will be deemed to have the same effect as if the original signature had been delivered to the other party.

**SIGNED AND SEALED** this \_\_\_\_\_ day of \_\_\_\_\_, 202\_

\_\_\_\_\_  
 (Name of Surety Company)  
 By \_\_\_\_\_  
 (Signature)

Its \_\_\_\_\_  
 (Title of Office)

Approved as to form:

\_\_\_\_\_  
Atleen Kaur, City Attorney

\_\_\_\_\_  
 (Name of Principal)  
 By \_\_\_\_\_  
 (Signature)

Its \_\_\_\_\_  
 (Title of Office)

Name and address of agent:

\_\_\_\_\_  
 \_\_\_\_\_  
 \_\_\_\_\_

## **GENERAL CONDITIONS**

### **Section 1 - Execution, Correlation and Intent of Documents**

The contract documents shall be signed in 2 copies by the City and the Contractor.

The contract documents are complementary and what is called for by any one shall be binding. The intention of the documents is to include all labor and materials, equipment and transportation necessary for the proper execution of the work. Materials or work described in words which so applied have a well-known technical or trade meaning have the meaning of those recognized standards.

In case of a conflict among the contract documents listed below in any requirement(s), the requirement(s) of the document listed first shall prevail over any conflicting requirement(s) of a document listed later.

(1) Addenda in reverse chronological order; (2) Detailed Specifications; (3) Standard Specifications; (4) Plans; (5) General Conditions; (6) Contract; (7) Bid Forms; (8) Bond Forms; (9) Bid.

### **Section 2 - Order of Completion**

The Contractor shall submit with each invoice, and at other times reasonably requested by the Supervising Professional, schedules showing the order in which the Contractor proposes to carry on the work. They shall include the dates at which the Contractor will start the several parts of the work, the estimated dates of completion of the several parts, and important milestones within the several parts.

### **Section 3 - Familiarity with Work**

The Bidder or its representative shall make personal investigations of the site of the work and of existing structures and shall determine to its own satisfaction the conditions to be encountered, the nature of the ground, the difficulties involved, and all other factors affecting the work proposed under this Contract. The Bidder to whom this Contract is awarded will not be entitled to any additional compensation unless conditions are clearly different from those which could reasonably have been anticipated by a person making diligent and thorough investigation of the site.

The Bidder shall immediately notify the City upon discovery, and in every case prior to submitting its Bid, of every error or omission in the bidding documents that would be identified by a reasonably competent, diligent Bidder. In no case will a Bidder be allowed the benefit of extra compensation or time to complete the work under this Contract for extra expenses or time spent as a result of the error or omission.

### **Section 4 - Wage Requirements**

Under this Contract, the Contractor shall conform to Chapter 14 of Title I of the Code of the City of Ann Arbor as amended; which in part states "...that all craftsmen, mechanics and laborers employed directly on the site in connection with said improvements, including said employees of

subcontractors, shall receive the prevailing wage for the corresponding classes of craftsmen, mechanics and laborers, as determined by statistics for the Ann Arbor area compiled by the United States Department of Labor. At the request of the City, any contractor or subcontractor shall provide satisfactory proof of compliance with the contract provisions required by the Section.

Pursuant to Resolution R-16-469 all public improvement contractors are subject to prevailing wage and will be required to provide to the City payroll records sufficient to demonstrate compliance with the prevailing wage requirements. A sample Prevailing Wage Form is provided in the Appendix herein for reference as to what will be expected from contractors. Use of the Prevailing Wage Form provided in the Appendix section or a City-approved equivalent will be required along with wage rate interviews.

Where the Contract and the Ann Arbor City Ordinance are silent as to definitions of terms required in determining contract compliance with regard to prevailing wages, the definitions provided in the Davis-Bacon Act as amended (40 U.S.C. 278-a to 276-a-7) for the terms shall be used.

If the Contractor is a "covered employer" as defined in Chapter 23 of the Ann Arbor City Code, the Contractor agrees to comply with the living wage provisions of Chapter 23 of the Ann Arbor City Code. The Contractor agrees to pay those employees providing Services to the City under this Contract a "living wage," as defined in Section 1:815 of the Ann Arbor City Code, as adjusted in accordance with Section 1:815(3); to post a notice approved by the City of the applicability of Chapter 23 in every location in which regular or contract employees providing services under this Contract are working; to maintain records of compliance; if requested by the City, to provide documentation to verify compliance; to take no action that would reduce the compensation, wages, fringe benefits, or leave available to any employee or person contracted for employment in order to pay the living wage required by Section 1:815; and otherwise to comply with the requirements of Chapter 23.

Contractor agrees that all subcontracts entered into by the Contractor shall contain similar wage provision covering subcontractor's employees who perform work on this contract.

## **Section 5 - Non-Discrimination**

The Contractor agrees to comply, and to require its subcontractor(s) to comply, with the nondiscrimination provisions of MCL 37.2209. The Contractor further agrees to comply with the provisions of Section 9:158 of Chapter 112 of Title IX of the Ann Arbor City Code, and to assure that applicants are employed and that employees are treated during employment in a manner which provides equal employment opportunity.

## **Section 6 - Materials, Appliances, Employees**

Unless otherwise stipulated, the Contractor shall provide and pay for all materials, labor, water, tools, equipment, light, power, transportation, and other facilities necessary or used for the execution and completion of the work. Unless otherwise specified, all materials incorporated in the permanent work shall be new, and both workmanship and materials shall be of the highest quality. The Contractor shall, if required, furnish satisfactory evidence as to the kind and quality of materials.

The Contractor shall at all times enforce strict discipline and good order among its employees, and shall seek to avoid employing on the work any unfit person or anyone not skilled in the work assigned.

Adequate sanitary facilities shall be provided by the Contractor.

### **Section 7 - Qualifications for Employment**

The Contractor shall employ competent laborers and mechanics for the work under this Contract. For work performed under this Contract, employment preference shall be given to qualified local residents.

### **Section 8 - Royalties and Patents**

The Contractor shall pay all royalties and license fees. It shall defend all suits or claims for infringements of any patent rights and shall hold the City harmless from loss on account of infringement except that the City shall be responsible for all infringement loss when a particular process or the product of a particular manufacturer or manufacturers is specified, unless the City has notified the Contractor prior to the signing of the Contract that the particular process or product is patented or is believed to be patented.

### **Section 9 - Permits and Regulations**

The Contractor must secure and pay for all permits, permit or plan review fees and licenses necessary for the prosecution of the work. These include but are not limited to City building permits, right-of-way permits, lane closure permits, right-of-way occupancy permits, and the like. The City shall secure and pay for easements shown on the plans unless otherwise specified.

The Contractor shall give all notices and comply with all laws, ordinances, rules and regulations bearing on the conduct of the work as drawn and specified. If the Contractor observes that the contract documents are at variance with those requirements, it shall promptly notify the Supervising Professional in writing, and any necessary changes shall be adjusted as provided in the Contract for changes in the work.

### **Section 10 - Protection of the Public and of Work and Property**

The Contractor is responsible for the means, methods, sequences, techniques and procedures of construction and safety programs associated with the work contemplated by this contract. The Contractor, its agents or sub-contractors, shall comply with the "General Rules and Regulations for the Construction Industry" as published by the Construction Safety Commission of the State of Michigan and to all other local, State and National laws, ordinances, rules and regulations pertaining to safety of persons and property.

The Contractor shall take all necessary and reasonable precautions to protect the safety of the public. It shall continuously maintain adequate protection of all work from damage, and shall take all necessary and reasonable precautions to adequately protect all public and private property from injury or loss arising in connection with this Contract. It shall make good any damage, injury or loss to its work and to public and private property resulting from lack of reasonable protective precautions, except as may be due to errors in the contract documents, or caused by agents or

employees of the City. The Contractor shall obtain and maintain sufficient insurance to cover damage to any City property at the site by any cause.

In an emergency affecting the safety of life, or the work, or of adjoining property, the Contractor is, without special instructions or authorization from the Supervising Professional, permitted to act at its discretion to prevent the threatened loss or injury. It shall also so act, without appeal, if authorized or instructed by the Supervising Professional.

Any compensation claimed by the Contractor for emergency work shall be determined by agreement or in accordance with the terms of Claims for Extra Cost - Section 15.

## **Section 11 - Inspection of Work**

The City shall provide sufficient competent personnel for the inspection of the work.

The Supervising Professional shall at all times have access to the work whenever it is in preparation or progress, and the Contractor shall provide proper facilities for access and for inspection.

If the specifications, the Supervising Professional's instructions, laws, ordinances, or any public authority require any work to be specially tested or approved, the Contractor shall give the Supervising Professional timely notice of its readiness for inspection, and if the inspection is by an authority other than the Supervising Professional, of the date fixed for the inspection. Inspections by the Supervising Professional shall be made promptly, and where practicable at the source of supply. If any work should be covered up without approval or consent of the Supervising Professional, it must, if required by the Supervising Professional, be uncovered for examination and properly restored at the Contractor's expense.

Re-examination of any work may be ordered by the Supervising Professional, and, if so ordered, the work must be uncovered by the Contractor. If the work is found to be in accordance with the contract documents, the City shall pay the cost of re-examination and replacement. If the work is not in accordance with the contract documents, the Contractor shall pay the cost.

## **Section 12 - Superintendence**

The Contractor shall keep on the work site, during its progress, a competent superintendent and any necessary assistants, all satisfactory to the Supervising Professional. The superintendent will be responsible to perform all on-site project management for the Contractor. The superintendent shall be experienced in the work required for this Contract. The superintendent shall represent the Contractor and all direction given to the superintendent shall be binding as if given to the Contractor. Important directions shall immediately be confirmed in writing to the Contractor. Other directions will be confirmed on written request. The Contractor shall give efficient superintendence to the work, using its best skill and attention.

## **Section 13 - Changes in the Work**

The City may make changes to the quantities of work within the general scope of the Contract at any time by a written order and without notice to the sureties. If the changes add to or deduct from the extent of the work, the Contract Sum shall be adjusted accordingly. All the changes shall be



executed under the conditions of the original Contract except that any claim for extension of time caused by the change shall be adjusted at the time of ordering the change.

In giving instructions, the Supervising Professional shall have authority to make minor changes in the work not involving extra cost and not inconsistent with the purposes of the work, but otherwise, except in an emergency endangering life or property, no extra work or change shall be made unless in pursuance of a written order by the Supervising Professional, and no claim for an addition to the Contract Sum shall be valid unless the additional work was ordered in writing.

The Contractor shall proceed with the work as changed and the value of the work shall be determined as provided in Claims for Extra Cost - Section 15.

### **Section 14 - Extension of Time**

Extension of time stipulated in the Contract for completion of the work will be made if and as the Supervising Professional may deem proper under any of the following circumstances:

- (1) When work under an extra work order is added to the work under this Contract;
- (2) When the work is suspended as provided in Section 20;
- (3) When the work of the Contractor is delayed on account of conditions which could not have been foreseen, or which were beyond the control of the Contractor, and which were not the result of its fault or negligence;
- (4) Delays in the progress of the work caused by any act or neglect of the City or of its employees or by other Contractors employed by the City;
- (5) Delay due to an act of Government;
- (6) Delay by the Supervising Professional in the furnishing of plans and necessary information;
- (7) Other cause which in the opinion of the Supervising Professional entitles the Contractor to an extension of time.

The Contractor shall notify the Supervising Professional within 7 days of an occurrence or conditions which, in the Contractor's opinion, entitle it to an extension of time. The notice shall be in writing and submitted in ample time to permit full investigation and evaluation of the Contractor's claim. The Supervising Professional shall acknowledge receipt of the Contractor's notice within 7 days of its receipt. Failure to timely provide the written notice shall constitute a waiver by the Contractor of any claim.

In situations where an extension of time in contract completion is appropriate under this or any other section of the contract, the Contractor understands and agrees that the only available adjustment for events that cause any delays in contract completion shall be extension of the required time for contract completion and that there shall be no adjustments in the money due the Contractor on account of the delay.

## **Section 15 - Claims for Extra Cost**

If the Contractor claims that any instructions by drawings or other media issued after the date of the Contract involved extra cost under this Contract, it shall give the Supervising Professional written notice within 7 days after the receipt of the instructions, and in any event before proceeding to execute the work, except in emergency endangering life or property. The procedure shall then be as provided for Changes in the Work-Section I3. No claim shall be valid unless so made.

If the Supervising Professional orders, in writing, the performance of any work not covered by the contract documents, and for which no item of work is provided in the Contract, and for which no unit price or lump sum basis can be agreed upon, then the extra work shall be done on a Cost-Plus-Percentage basis of payment as follows:

- (1) The Contractor shall be reimbursed for all reasonable costs incurred in doing the work, and shall receive an additional payment of 15% of all the reasonable costs to cover both its indirect overhead costs and profit;
- (2) The term "Cost" shall cover all payroll charges for employees and supervision required under the specific order, together with all worker's compensation, Social Security, pension and retirement allowances and social insurance, or other regular payroll charges on same; the cost of all material and supplies required of either temporary or permanent character; rental of all power-driven equipment at agreed upon rates, together with cost of fuel and supply charges for the equipment; and any costs incurred by the Contractor as a direct result of executing the order, if approved by the Supervising Professional;
- (3) If the extra is performed under subcontract, the subcontractor shall be allowed to compute its charges as described above. The Contractor shall be permitted to add an additional charge of 5% percent to that of the subcontractor for the Contractor's supervision and contractual responsibility;
- (4) The quantities and items of work done each day shall be submitted to the Supervising Professional in a satisfactory form on the succeeding day, and shall be approved by the Supervising Professional and the Contractor or adjusted at once;
- (5) Payments of all charges for work under this Section in any one month shall be made along with normal progress payments. Retainage shall be in accordance with Progress Payments-Section 16.

No additional compensation will be provided for additional equipment, materials, personnel, overtime or special charges required to perform the work within the time requirements of the Contract.

When extra work is required and no suitable price for machinery and equipment can be determined in accordance with this Section, the hourly rate paid shall be 1/40 of the basic weekly rate listed in the Rental Rate Blue Book published by Dataquest Incorporated and applicable to the time period the equipment was first used for the extra work. The hourly rate will be deemed to include all costs of operation such as bucket or blade, fuel, maintenance, "regional factors", insurance, taxes, and the like, but not the costs of the operator.

## **Section 16 - Progress Payments**

The Contractor shall submit each month, or at longer intervals, if it so desires, an invoice covering work performed for which it believes payment, under the Contract terms, is due. The submission shall be to the City's Finance Department - Accounting Division. The Supervising Professional will, within 10 days following submission of the invoice, prepare a certificate for payment for the work in an amount to be determined by the Supervising Professional as fairly representing the acceptable work performed during the period covered by the Contractor's invoice. To insure the proper performance of this Contract, the City will retain a percentage of the estimate in accordance with Act 524, Public Acts of 1980. The City will then, following the receipt of the Supervising Professional's Certificate, make payment to the Contractor as soon as feasible, which is anticipated will be within 15 days.

An allowance may be made in progress payments if substantial quantities of permanent material have been delivered to the site but not incorporated in the completed work if the Contractor, in the opinion of the Supervising Professional, is diligently pursuing the work under this Contract. Such materials shall be properly stored and adequately protected. Allowance in the estimate shall be at the invoice price value of the items. Notwithstanding any payment of any allowance, all risk of loss due to vandalism or any damages to the stored materials remains with the Contractor.

In the case of Contracts which include only the Furnishing and Delivering of Equipment, the payments shall be; 60% of the Contract Sum upon the delivery of all equipment to be furnished, or in the case of delivery of a usable portion of the equipment in advance of the total equipment delivery, 60% of the estimated value of the portion of the equipment may be paid upon its delivery in advance of the time of the remainder of the equipment to be furnished; 30% of the Contract Sum upon completion of erection of all equipment furnished, but not later than 60 days after the date of delivery of all of the equipment to be furnished; and payment of the final 10% on final completion of erection, testing and acceptance of all the equipment to be furnished; but not later than 180 days after the date of delivery of all of the equipment to be furnished, unless testing has been completed and shows the equipment to be unacceptable.

With each invoice for periodic payment, the Contractor shall enclose a Contractor's Declaration - Section 43, and an updated project schedule per Order of Completion - Section 2.

## **Section 17 - Deductions for Uncorrected Work**

If the Supervising Professional decides it is inexpedient to correct work that has been damaged or that was not done in accordance with the Contract, an equitable deduction from the Contract price shall be made.

## **Section 18 - Correction of Work Before Final Payment**

The Contractor shall promptly remove from the premises all materials condemned by the Supervising Professional as failing to meet Contract requirements, whether incorporated in the work or not, and the Contractor shall promptly replace and re-execute the work in accordance with the Contract and without expense to the City and shall bear the expense of making good all work of other contractors destroyed or damaged by the removal or replacement.

If the Contractor does not remove the condemned work and materials within 10 days after written notice, the City may remove them and, if the removed material has value, may store the material

at the expense of the Contractor. If the Contractor does not pay the expense of the removal within 10 days thereafter, the City may, upon 10 days written notice, sell the removed materials at auction or private sale and shall pay to the Contractor the net proceeds, after deducting all costs and expenses that should have been borne by the Contractor. If the removed material has no value, the Contractor must pay the City the expenses for disposal within 10 days of invoice for the disposal costs.

The inspection or lack of inspection of any material or work pertaining to this Contract shall not relieve the Contractor of its obligation to fulfill this Contract and defective work shall be made good. Unsuitable materials may be rejected by the Supervising Professional notwithstanding that the work and materials have been previously overlooked by the Supervising Professional and accepted or estimated for payment or paid for. If the work or any part shall be found defective at any time before the final acceptance of the whole work, the Contractor shall forthwith make good the defect in a manner satisfactory to the Supervising Professional. The judgment and the decision of the Supervising Professional as to whether the materials supplied and the work done under this Contract comply with the requirements of the Contract shall be conclusive and final.

## **Section 19 - Acceptance and Final Payment**

Upon receipt of written notice that the work is ready for final inspection and acceptance, the Supervising Professional will promptly make the inspection. When the Supervising Professional finds the work acceptable under the Contract and the Contract fully performed, the Supervising Professional will promptly sign and issue a final certificate stating that the work required by this Contract has been completed and is accepted by the City under the terms and conditions of the Contract. The entire balance found to be due the Contractor, including the retained percentage, shall be paid to the Contractor by the City within 30 days after the date of the final certificate.

Before issuance of final certificates, the Contractor shall file with the City:

- (1) The consent of the surety to payment of the final estimate;
- (2) The Contractor's Affidavit in the form required by Section 44.

In case the Affidavit or consent is not furnished, the City may retain out of any amount due the Contractor, sums sufficient to cover all lienable claims.

The making and acceptance of the final payment shall constitute a waiver of all claims by the City except those arising from:

- (1) unsettled liens;
- (2) faulty work appearing within 12 months after final payment;
- (3) hidden defects in meeting the requirements of the plans and specifications;
- (4) manufacturer's guarantees.

It shall also constitute a waiver of all claims by the Contractor, except those previously made and still unsettled.

## **Section 20 - Suspension of Work**

The City may at any time suspend the work, or any part by giving 5 days notice to the Contractor in writing. The work shall be resumed by the Contractor within 10 days after the date fixed in the

written notice from the City to the Contractor to do so. The City shall reimburse the Contractor for expense incurred by the Contractor in connection with the work under this Contract as a result of the suspension.

If the work, or any part, shall be stopped by the notice in writing, and if the City does not give notice in writing to the Contractor to resume work at a date within 90 days of the date fixed in the written notice to suspend, then the Contractor may abandon that portion of the work suspended and will be entitled to the estimates and payments for all work done on the portions abandoned, if any, plus 10% of the value of the work abandoned, to compensate for loss of overhead, plant expense, and anticipated profit.

## **Section 21 - Delays and the City's Right to Terminate Contract**

If the Contractor refuses or fails to prosecute the work, or any separate part of it, with the diligence required to insure completion, ready for operation, within the allowable number of consecutive calendar days specified plus extensions, or fails to complete the work within the required time, the City may, by written notice to the Contractor, terminate its right to proceed with the work or any part of the work as to which there has been delay. After providing the notice the City may take over the work and prosecute it to completion, by contract or otherwise, and the Contractor and its sureties shall be liable to the City for any excess cost to the City. If the Contractor's right to proceed is terminated, the City may take possession of and utilize in completing the work, any materials, appliances and plant as may be on the site of the work and useful for completing the work. The right of the Contractor to proceed shall not be terminated or the Contractor charged with liquidated damages where an extension of time is granted under Extension of Time - Section 14.

If the Contractor is adjudged a bankrupt, or if it makes a general assignment for the benefit of creditors, or if a receiver is appointed on account of its insolvency, or if it persistently or repeatedly refuses or fails except in cases for which extension of time is provided, to supply enough properly skilled workers or proper materials, or if it fails to make prompt payments to subcontractors or for material or labor, or persistently disregards laws, ordinances or the instructions of the Supervising Professional, or otherwise is guilty of a substantial violation of any provision of the Contract, then the City, upon the certificate of the Supervising Professional that sufficient cause exists to justify such action, may, without prejudice to any other right or remedy and after giving the Contractor 3 days written notice, terminate this Contract. The City may then take possession of the premises and of all materials, tools and appliances thereon and without prejudice to any other remedy it may have, make good the deficiencies or finish the work by whatever method it may deem expedient, and deduct the cost from the payment due the Contractor. The Contractor shall not be entitled to receive any further payment until the work is finished. If the expense of finishing the work, including compensation for additional managerial and administrative services exceeds the unpaid balance of the Contract Sum, the Contractor and its surety are liable to the City for any excess cost incurred. The expense incurred by the City, and the damage incurred through the Contractor's default, shall be certified by the Supervising Professional.

## **Section 22 - Contractor's Right to Terminate Contract**

If the work should be stopped under an order of any court, or other public authority, for a period of 3 months, through no act or fault of the Contractor or of anyone employed by it, then the Contractor may, upon 7 days written notice to the City, terminate this Contract and recover from the City payment for all acceptable work executed plus reasonable profit.

## **Section 23 - City's Right To Do Work**

If the Contractor should neglect to prosecute the work properly or fail to perform any provision of this Contract, the City, 3 days after giving written notice to the Contractor and its surety may, without prejudice to any other remedy the City may have, make good the deficiencies and may deduct the cost from the payment due to the Contractor.

## **Section 24 - Removal of Equipment and Supplies**

In case of termination of this Contract before completion, from any or no cause, the Contractor, if notified to do so by the City, shall promptly remove any part or all of its equipment and supplies from the property of the City, failing which the City shall have the right to remove the equipment and supplies at the expense of the Contractor.

The removed equipment and supplies may be stored by the City and, if all costs of removal and storage are not paid by the Contractor within 10 days of invoicing, the City upon 10 days written notice may sell the equipment and supplies at auction or private sale, and shall pay the Contractor the net proceeds after deducting all costs and expenses that should have been borne by the Contractor and after deducting all amounts claimed due by any lien holder of the equipment or supplies.

## **Section 25 - Responsibility for Work and Warranties**

The Contractor assumes full responsibility for any and all materials and equipment used in the construction of the work and may not make claims against the City for damages to materials and equipment from any cause except negligence or willful act of the City. Until its final acceptance, the Contractor shall be responsible for damage to or destruction of the project (except for any part covered by Partial Completion and Acceptance - Section 26). The Contractor shall make good all work damaged or destroyed before acceptance. All risk of loss remains with the Contractor until final acceptance of the work (Section 19) or partial acceptance (Section 26). The Contractor is advised to investigate obtaining its own builders risk insurance.

The Contractor shall guarantee the quality of the work for a period of one year. The Contractor shall also unconditionally guarantee the quality of all equipment and materials that are furnished and installed under the contract for a period of one year. At the end of one year after the Contractor's receipt of final payment, the complete work, including equipment and materials furnished and installed under the contract, shall be inspected by the Contractor and the Supervising Professional. Any defects shall be corrected by the Contractor at its expense as soon as practicable but in all cases within 60 days. Any defects that are identified prior to the end of one year shall also be inspected by the Contractor and the Supervising Professional and shall be corrected by the Contractor at its expense as soon as practicable but in all cases within 60 days. The Contractor shall assign all manufacturer or material supplier warranties to the City prior to final payment. The assignment shall not relieve the Contractor of its obligations under this paragraph to correct defects.

## **Section 26 - Partial Completion and Acceptance**

If at any time prior to the issuance of the final certificate referred to in Acceptance and Final Payment - Section 19, any portion of the permanent construction has been satisfactorily completed, and if the Supervising Professional determines that portion of the permanent construction is not required for the operations of the Contractor but is needed by the City, the Supervising Professional shall issue to the Contractor a certificate of partial completion, and immediately the City may take over and use the portion of the permanent construction described in the certificate, and exclude the Contractor from that portion.

The issuance of a certificate of partial completion shall not constitute an extension of the Contractor's time to complete the portion of the permanent construction to which it relates if the Contractor has failed to complete it in accordance with the terms of this Contract. The issuance of the certificate shall not release the Contractor or its sureties from any obligations under this Contract including bonds.

If prior use increases the cost of, or delays the work, the Contractor shall be entitled to extra compensation, or extension of time, or both, as the Supervising Professional may determine.

## **Section 27 - Payments Withheld Prior to Final Acceptance of Work**

The City may withhold or, on account of subsequently discovered evidence, nullify the whole or part of any certificate to the extent reasonably appropriate to protect the City from loss on account of:

- (1) Defective work not remedied;
- (2) Claims filed or reasonable evidence indicating probable filing of claims by other parties against the Contractor;
- (3) Failure of the Contractor to make payments properly to subcontractors or for material or labor;
- (4) Damage to another Contractor.

When the above grounds are removed or the Contractor provides a Surety Bond satisfactory to the City which will protect the City in the amount withheld, payment shall be made for amounts withheld under this section.

## **Section 28 - Contractor's Insurance**

- (1) The Contractor shall procure and maintain during the life of this Contract, including the guarantee period and during any warranty work, such insurance policies, including those set forth below, as will protect itself and the City from all claims for bodily injuries, death or property damage that may arise under this Contract; whether the act(s) or omission(s) giving rise to the claim were made by the Contractor, any subcontractor, or anyone employed by them directly or indirectly. Prior to commencement of any work under this contract, Contractor shall provide to the City documentation satisfactory to the City, through City-approved means (currently myCOI), demonstrating it has obtained the required policies and endorsements. The certificates of insurance endorsements and/or copies of

policy language shall document that the Contractor satisfies the following minimum requirements. Contractor shall add registration@mycoitracking.com to its safe sender's list so that it will receive necessary communication from myCOI. When requested, Contractor shall provide the same documentation for its subcontractor(s) (if any).

Required insurance policies include:

- (a) Worker's Compensation Insurance in accordance with all applicable state and federal statutes. Further, Employers Liability Coverage shall be obtained in the following minimum amounts:

- Bodily Injury by Accident - \$500,000 each accident
  - Bodily Injury by Disease - \$500,000 each employee
  - Bodily Injury by Disease - \$500,000 each policy limit

- (b) Commercial General Liability Insurance equivalent to, as a minimum, Insurance Services Office form CG 00 01 04 13 or current equivalent. The City of Ann Arbor shall be named as an additional insured. There shall be no added exclusions or limiting endorsements specifically for the following coverages: Products and Completed Operations, Explosion, Collapse and Underground coverage or Pollution. Further there shall be no added exclusions or limiting endorsements that diminish the City's protections as an additional insured under the policy. The following minimum limits of liability are required:

- \$1,000,000 Each occurrence as respect Bodily Injury Liability or Property Damage Liability, or both combined.
  - \$2,000,000 Per Project General Aggregate
  - \$1,000,000 Personal and Advertising Injury
  - \$2,000,000 Products and Completed Operations Aggregate, which, notwithstanding anything to the contrary herein, shall be maintained for three years from the date the Project is completed.

- (c) Motor Vehicle Liability Insurance, including Michigan No-Fault Coverages, equivalent to, as a minimum, Insurance Services Office form CA 00 01 10 13 or current equivalent. Coverage shall include all owned vehicles, all non-owned vehicles and all hired vehicles. The City of Ann Arbor shall be named as an additional insured. There shall be no added exclusions or limiting endorsements that diminish the City's protections as an additional insured under the policy. Further, the limits of liability shall be \$1,000,000 for each occurrence as respects Bodily Injury Liability or Property Damage Liability, or both combined.

- (d) Umbrella/Excess Liability Insurance shall be provided to apply excess of the Commercial General Liability, Employers Liability and the Motor Vehicle coverage enumerated above, for each occurrence and for aggregate in the amount of \$1,000,000.

- (2) Insurance required under subsection (1)(b) and (1)(c) above shall be considered primary as respects any other valid or collectible insurance that the City may possess, including any self-insured retentions the City may have; and any other insurance the City does possess shall be considered excess insurance only and shall not be required to contribute



with this insurance. Further, the Contractor agrees to waive any right of recovery by its insurer against the City for any insurance listed herein.

- (3) Insurance companies and policy forms are subject to approval of the City Attorney, which approval shall not be unreasonably withheld. Documentation must provide and demonstrate an unconditional and un-qualified 30-day written notice of cancellation in favor of the City of Ann Arbor. Further, the documentation must explicitly state the following: (a) the policy number(s); name of insurance company(s); name and address of the agent(s) or authorized representative(s); name(s), email address(es), and address of insured; project name; policy expiration date; and specific coverage amounts; (b) any deductibles or self-insured retentions which may be approved by the City, in its sole discretion; (c) that the policy conforms to the requirements specified Contractor shall furnish the City with satisfactory certificates of insurance and endorsements prior to commencement of any work. Upon request, the Contractor shall provide within 30 days a copy of the policy(ies) and all required endorsements to the City. If any of the above coverages expire by their terms during the term of this Contract, the Contractor shall deliver proof of renewal and/or new policies and endorsements to the Administering Service Area/Unit at least ten days prior to the expiration date.
- (4) Any Insurance provider of Contractor shall be authorized to do business in the State of Michigan and shall carry and maintain a minimum rating assigned by A.M. Best & Company's Key Rating Guide of "A-" Overall and a minimum Financial Size Category of "V". Insurance policies and certificates issued by non-authorized insurance companies are not acceptable unless approved in writing by the City.
- (5) City reserves the right to require additional coverage and/or coverage amounts as may be included from time to time in the Detailed Specifications for the Project. Refer to Special Provision for Railroad Insurance Requirements.
- (6) The provisions of General Condition 28 shall survive the expiration or earlier termination of this contract for any reason.
- (7) The Contractor shall provide Builders Risk Insurance if required for the Project by Amtrak and/or MDOT Office of Rail.

## **Section 29 - Surety Bonds**

Bonds will be required from the successful bidder as follows:

- (1) A Performance Bond to the City of Ann Arbor for the amount of the bid(s) accepted;
- (2) A Labor and Material Bond to the City of Ann Arbor for the amount of the bid(s) accepted.

Bonds shall be executed on forms supplied by the City in a manner and by a Surety Company authorized to transact business in Michigan and satisfactory to the City Attorney.

## **Section 30 - Damage Claims**

The Contractor shall be held responsible for all damages to property of the City or others, caused by or resulting from the negligence of the Contractor, its employees, or agents during the progress of or connected with the prosecution of the work, whether within the limits of the work or elsewhere. The Contractor must restore all property injured including sidewalks, curbing, sodding, pipes, conduit, sewers or other public or private property to not less than its original condition with new work.

## **Section 31 - Refusal to Obey Instructions**

If the Contractor refuses to obey the instructions of the Supervising Professional, the Supervising Professional shall withdraw inspection from the work, and no payments will be made for work performed thereafter nor may work be performed thereafter until the Supervising Professional shall have again authorized the work to proceed.

## **Section 32 - Assignment**

Neither party to the Contract shall assign the Contract without the written consent of the other. The Contractor may assign any monies due to it to a third party acceptable to the City.

## **Section 33 - Rights of Various Interests**

Whenever work being done by the City's forces or by other contractors is contiguous to work covered by this Contract, the respective rights of the various interests involved shall be established by the Supervising Professional, to secure the completion of the various portions of the work in general harmony.

The Contractor is responsible to coordinate all aspects of the work, including coordination of, and with, utility companies and other contractors whose work impacts this project.

## **Section 34 - Subcontracts**

The Contractor shall not award any work to any subcontractor without prior written approval of the City. The approval will not be given until the Contractor submits to the City a written statement concerning the proposed award to the subcontractor. The statement shall contain all information the City may require.

The Contractor shall be as fully responsible to the City for the acts and omissions of its subcontractors, and of persons either directly or indirectly employed by them, as it is for the acts and omissions of persons directly employed by it.

The Contractor shall cause appropriate provisions to be inserted in all subcontracts relative to the work to bind subcontractors to the Contractor by the terms of the General Conditions and all other contract documents applicable to the work of the subcontractors and to give the Contractor the same power to terminate any subcontract that the City may exercise over the Contractor under any provision of the contract documents.

Nothing contained in the contract documents shall create any contractual relation between any subcontractor and the City.

### **Section 35 - Supervising Professional's Status**

The Supervising Professional has the right to inspect any or all work. The Supervising Professional has authority to stop the work whenever stoppage may be appropriate to insure the proper execution of the Contract. The Supervising Professional has the authority to reject all work and materials which do not conform to the Contract and to decide questions which arise in the execution of the work.

The Supervising Professional shall make all measurements and determinations of quantities. Those measurements and determinations are final and conclusive between the parties.

### **Section 36 - Supervising Professional's Decisions**

The Supervising Professional shall, within a reasonable time after their presentation to the Supervising Professional, make decisions in writing on all claims of the City or the Contractor and on all other matters relating to the execution and progress of the work or the interpretation of the contract documents.

### **Section 37 - Storing Materials and Supplies**

Materials and supplies may be stored at the site of the work at locations agreeable to the City unless specific exception is listed elsewhere in these documents. Ample way for foot traffic and drainage must be provided, and gutters must, at all times, be kept free from obstruction. Traffic on streets shall be interfered with as little as possible. The Contractor may not enter or occupy with agents, employees, tools, or material any private property without first obtaining written permission from its owner. A copy of the permission shall be furnished to the Supervising Professional.

### **Section 38 - Lands for Work**

The Contractor shall provide, at its own expense and without liability to the City, any additional land and access that may be required for temporary construction facilities or for storage of materials.

### **Section 39 - Cleaning Up**

The Contractor shall, as directed by the Supervising Professional, remove at its own expense from the City's property and from all public and private property all temporary structures, rubbish and waste materials resulting from its operations unless otherwise specifically approved, in writing, by the Supervising Professional.

### **Section 40 - Salvage**

The Supervising Professional may designate for salvage any materials from existing structures or underground services. Materials so designated remain City property and shall be transported or stored at a location as the Supervising Professional may direct.

## **Section 41 - Night, Saturday or Sunday Work**

Except for the planned railroad track outage, no night or Sunday work (without prior written City approval) will be permitted except in the case of an emergency and then only to the extent absolutely necessary. The City may allow night work which, in the opinion of the Supervising Professional, can be satisfactorily performed at night. Night work is any work between 8:00 p.m. and 7:00 a.m. No Saturday work will be permitted unless the Contractor gives the Supervising Professional at least 48 hours but not more than 5 days notice of the Contractor's intention to work the upcoming Saturday.

## **Section 42 - Sales Taxes**

Under State law the City is exempt from the assessment of State Sales Tax on its direct purchases. Contractors who acquire materials, equipment, supplies, etc. for incorporation in City projects are not likewise exempt. State Law shall prevail. The Bidder shall familiarize itself with the State Law and prepare its Bid accordingly. No extra payment will be allowed under this Contract for failure of the Contractor to make proper allowance in this bid for taxes it must pay.

**Section 43**

**CONTRACTOR'S DECLARATION**

I hereby declare that I have not, during the period \_\_\_\_\_, 20\_\_\_\_, to \_\_\_\_\_, 20\_\_\_\_, performed any work, furnished any materials, sustained any loss, damage or delay, or otherwise done anything in addition to the regular items (or executed change orders) set forth in the Contract titled \_\_\_\_\_, for which I shall ask, demand, sue for, or claim compensation or extension of time from the City, except as I hereby make claim for additional compensation or extension of time as set forth on the attached itemized statement. I further declare that I have paid all payroll obligations related to this Contract that have become due during the above period and that all invoices related to this Contract received more than 30 days prior to this declaration have been paid in full except as listed below.

There is/is not (Contractor please circle one and strike one as appropriate) an itemized statement attached regarding a request for additional compensation or extension of time.

\_\_\_\_\_  
Contractor

\_\_\_\_\_  
Date

By \_\_\_\_\_  
(Signature)

Its \_\_\_\_\_  
(Title of Office)

Past due invoices, if any, are listed below.

**Section 44**

**CONTRACTOR'S AFFIDAVIT**

The undersigned Contractor, \_\_\_\_\_, represents that on \_\_\_\_\_, 20\_\_, it was awarded a contract by the City of Ann Arbor, Michigan to \_\_\_\_\_ under the terms and conditions of a Contract titled \_\_\_\_\_. The Contractor represents that all work has now been accomplished and the Contract is complete.

The Contractor warrants and certifies that all of its indebtedness arising by reason of the Contract has been fully paid or satisfactorily secured; and that all claims from subcontractors and others for labor and material used in accomplishing the project, as well as all other claims arising from the performance of the Contract, have been fully paid or satisfactorily settled. The Contractor agrees that, if any claim should hereafter arise, it shall assume responsibility for it immediately upon request to do so by the City of Ann Arbor.

The Contractor, for valuable consideration received, does further waive, release and relinquish any and all claims or right of lien which the Contractor now has or may acquire upon the subject premises for labor and material used in the project owned by the City of Ann Arbor.

This affidavit is freely and voluntarily given with full knowledge of the facts.

\_\_\_\_\_  
Contractor

\_\_\_\_\_  
Date

By \_\_\_\_\_  
(Signature)

Its \_\_\_\_\_  
(Title of Office)

Subscribed and sworn to before me, on this \_\_\_\_\_ day of \_\_\_\_\_, 20\_\_  
\_\_\_\_\_, \_\_\_\_\_ County, Michigan

\_\_\_\_\_  
Notary Public

\_\_\_\_\_ County, MI  
My commission expires on:

## **STANDARD SPECIFICATIONS**

All work under this contract shall be performed in accordance with the Public Services Department Standard Specifications in effect at the date of availability of the contract documents stipulated in the Bid. All work under this Contract which is not included in these Standard Specifications, or which is performed using modifications to these Standard Specifications, shall be performed in accordance with the Detailed Specifications included in these contract documents.

Standard Specifications are available online:

<http://www.a2gov.org/departments/engineering/Pages/Engineering-and-Contractor-Resources.aspx>

## DETAILED SPECIFICATIONS

1. Certified Payroll Compliance and Reporting
2. Coordination Clause
3. Progress Clause
4. Utility Coordination Clause
5. Coordination Clause for Work on Railroad Property
6. Railroad Insurance Requirements
7. Railroad Inspection and Flagging
8. Work on Railroad Property, Amtrak
9. Clearing, Modified
10. Vertical Exploratory Investigation for Relocation
11. Non-Hazardous Contaminated Material Handling and Disposal
12. Dewatering System, Excavation
13. Erosion Control, Inlet Protection, Fabric Drop
14. Culvert, Precast Concrete Box, Modified
15. Dewatering System for Contaminated Groundwater
16. Slotted Drain, Galvanized
17. Cleanout
18. Revisions to Precast Three-Sided, Arch, and Box Culverts
19. Culvert Bedding
20. Steel Sheet Piling, Temporary
21. Decorative Panel, Furnish and Install
22. Timber Bridge
23. Modular Block Wall
24. Shared use Path, Aggregate, \_\_\_ inch, Modified
25. Shared use Path, Conc, \_\_\_ inch
26. Shared use Path, Grading, Modified
27. Fence, Rustic Split Rail
28. Fence, Chain Link, Special
29. Fence, Protective, Special
30. Ornamental Aluminum Fence, \_\_\_ inch
31. Temporary Pedestrian Type II Barricade
32. Temporary Pedestrian Type II Channelizer
33. Riprap, Cobblestone Check Dam, Cobblestone
34. Live Staking
35. Sewer, PVC, 6 inch, Trench Detail B
36. Turf Establishment, Performance
37. Decorative Light Standards
38. Electrical Utility Service
39. Fiber Optic and Telecom Utility Work
40. Lighting Control Panel
41. Railroad Track Monitoring – Amtrak for Barton Bandemer Tunnel
42. Liquidated Damages for Other Department Costs
43. Stone Masonry Façade



CITY OF ANN ARBOR  
SPECIAL PROVISION  
FOR  
**CERTIFIED PAYROLL COMPLIANCE AND REPORTING**

BBT:CED

1 of 2

3/8/24

**a. Description.** This work covers all administrative requirements, payroll reporting procedures to be followed by Contractors performing work on City-sponsored public improvements projects, and all other miscellaneous and incidental costs associated with complying with the applicable sections of the City of Ann Arbor Code of Ordinances with regard to payment of prevailing wages and its Prevailing Wage Compliance policy.

This specification is not intended to include the actual labor costs associated with the payment of prevailing wages as required. Those costs should be properly incorporated in all other items of work bid.

**b. General.** The Contractor is expected to comply with all applicable sections of Federal and State prevailing wage laws, duly promulgated regulations, the City of Ann Arbor Code of Ordinances, and its Prevailing Wage Compliance Policy as defined within the Contract Documents. The Contractor shall provide the required certified payrolls, City-required declarations, and reports requested elsewhere in the Contract Documents within the timeline(s) stipulated therein.

The Contractor shall also provide corrected copies of any submitted documents that are found to contain errors, omissions, inconsistencies, or other defects that render the report invalid. The corrected copies shall be provided when requested by the Supervising Professional.

The Contractor shall also attend any required meetings as needed to fully discuss and ensure compliance with the Contract requirements regarding prevailing wage compliance. The Contractor shall require all employees engaged in on-site work to participate in, provide the requested information to the extent practicable, and cooperate in the interview process. The City of Ann Arbor will provide the needed language interpreters in order to perform wage rate interviews or other field investigations as needed.

Certified Payrolls may be submitted on City-provided forms or forms used by the Contractor, as long as the Contractor's forms contain all required payroll information. If the Contractor elects to provide their own forms, the forms shall be approved by the Supervising Professional prior to the beginning of on-site work.

**c. Unbalanced Bidding.** The City of Ann Arbor will examine the submitted cost for this item of work prior to Contract award. If the City determines, in its sole discretion, that the costs bid by the Contractor for complying with the Contract requirements are not reasonable, accurately reported, or may contain discrepancies, the City reserves the right to request additional documentation that fully supports and justifies the price as bid. Should the submitted information not be determined to be reasonable or justify the costs, the City reserves the right to pursue award of the Contract to the second low bidder without penalty or prejudice to any other remedies that it may have or may elect to exercise with respect to the original low-bidder.

The Contract Completion date will not be extended as a result of the City’s investigation of the as-bid amount for this item of work, even if the anticipated contract award date must be adjusted. The only exception will be if the Contractor adequately demonstrates that their costs were appropriate and justifiable. If so, the City will adjust the Contract completion date by the number of calendar days commensurate with the length of the investigation, if the published Notice to Proceed date of the work cannot be met. The Contract unit prices for all other items of work will not be adjusted regardless of an adjustment of the Contract completion date being made

**d. Measurement and Payment.** The completed work, as described, will be measured as a lump sum and paid for at the contract price using the following pay item:

<b>Pay Item</b>	<b>Pay Unit</b>
Certified Payroll Compliance and Reporting .....	Lump Sum

The unit price for this item of work shall include all supervisory, accounting, administrative, and equipment costs needed to monitor and perform all work related to maintaining compliance with the tasks specified in this Detailed Specification, the City of Ann Arbor Code of Ordinances, its Prevailing Wage Compliance policy and the applicable Federal and State laws.

Payment for this work will be made with each progress payment, on a pro-rata basis, based on the percentage of construction completed. When all of the work of this Contract has been completed, the measurement of this item shall be 1.0 times the Lump Sum bid amount. This amount will not be increased for any reason, including extensions of time, extra work, and/or adjustments to existing items of work.

CITY OF ANN ARBOR  
SPECIAL PROVISION  
FOR  
**COORDINATION CLAUSE**

BBT:CED

1 of 2

3/12/24

Refer to section 104.08 of the Standard Specifications for Construction when coordinating other projects or dealing with other contractors in the work area.

Be aware of other projects that may be constructed within or near the Project Area during the same general period as this project and must coordinate their activities to minimize disturbance between this project and any other project in the vicinity. Known projects include, but are not limited to:

1. The City of Ann Arbor plans to perform work on the Barton Dam. The Barton Dam project is anticipated to begin in July 2024. This will include stockpiling of materials within Barton Park. Attend one coordination meeting with the Barton Dam Contractor.
2. The City of Ann Arbor/Washtenaw County Parks and Recreation Commission have a contract in place for constructing a concrete surfaced trail from Barton Park up to the north end of the south pedestrian bridge over the Huron River located near the project limits of this Project. Tree clearing and removals for this project were performed as part of this initial contract. Attend one coordination meeting with the Barton Nature Area Border to Border Trail Project Contractor.
3. MDOT Office of Rail is planning to install a new fence within the railroad right-of-way adjacent to the limits of this project. Timing is unknown but can be assumed to occur in 2025 or later.

As part of the coordination efforts associated with this project, prepare and submit a schedule in electronic format on a monthly basis. Provide advanced notice of changes in the anticipated project delivery date with a 30 day minimum notice.

Coordinate with local third-party vendors providing services to the park and area residents for trash collection, leaf pickup, street cleaning, mail, and other services. Coordinate construction activities to allow third-party vendors and service vehicles to access areas of the project site needed to complete their work.

Coordinate construction activities and traffic control measures with any of the projects listed or other authorized work within the City of Ann Arbor or MDOT Rail Right of Way.

It is the Contractor's responsibility to coordinate his/her work efforts with the other projects. Any additional costs incurred by the Contractor resulting from conflict with another project or work activities will be considered incidental and will not be paid for.

The Contractor will not receive a time extension due to work delays resulting from conflicts with another project or work activities. Refer to the Progress Clause for information on the required completion date and associated penalties.

No equipment will be permitted to cross the existing pedestrian bridges over the Huron River.

The existing vehicular bridge into Bandemer Park is load posted. Equipment cannot exceed the posting for this bridge.

The Contractor may access the site from Huron River Drive through previously cleared areas but must maintain traffic at all times along Huron River Drive.

Any additional permitting requirements associated with alternate access to this section of the project will be the responsibility of the Contractor.

CITY OF ANN ARBOR  
SPECIAL PROVISION  
FOR  
**PROGRESS CLAUSE**

BBT:CED

1 of 2

3/12/24

The Engineer anticipates that construction can begin no earlier than ten (10) calendar days after award or as directed by the Engineer.

In no case can any work be commenced prior to receipt of formal notice of award by the Department.

Prepare and submit a complete, detailed, signed Progress Schedule to the Engineer.

The Progress Schedule shall include, at minimum, the controlling work items for the completion of the project, as well as the planned dates or work days that these work items will be controlling operations. All contract dates including open to traffic, project completion, interim completion and any other controlling dates in the Contract, must be included in the Progress Schedule. If the bidding Proposal specifies other controlling dates, these shall also be included in the Progress Schedule.

The project shall be completed in its entirety including final site restoration and clean-up on or before **December 20<sup>th</sup>, 2024** excluding the acceptance of slope restoration, tree plantings, and watering & cultivating. Slope restoration and watering & cultivating requirements must be met prior to final acceptance of the project. A 36-hour track outage has been scheduled on, or about, **October 9<sup>th</sup>, 2024** for the purposes of constructing the project under the railroad tracks. If inclement weather occurs during the original track outage date, a back-up track outage date scheduled approximately 2 weeks after the originally scheduled outage must be coordinated with the Engineer. All work required for preparation for this outage must be done prior to **October 9<sup>th</sup>, 2024**. The actual outage start and stop times will be provided by the Engineer. The Contractor will be given a 30-hour uninterrupted time for which to construct the work required during the track outage.

The Contractor shall include an hour-by-hour schedule for the work planned during the track outage to be approved by the Engineer. The hour-by-hour schedule shall include the Contractor coordinating with Amtrak to show durations for the work tasks Amtrak will be responsible for during the track outage. The hour-by-hour schedule shall indicate an emergency stop work plan indicating the point at which the Contractor will no longer be able to stop and return the site to a condition ready for Amtrak to perform their work in reopening to rail traffic within the planned outage timeframe.

Unless specific pay items are provided in the contract, any extra costs incurred by the Contractor due to cold-weather protection and winter grading will not be paid for separately, but will be included in the payment of other pay items in the contract.

After award and prior to start of work, the Contractor must attend a preconstruction meeting with the Engineer. The Engineer will determine the date, time, and place for the preconstruction

meeting. The meeting will be conducted after project award and may be rescheduled if there are delays in the award of the project.

The named subcontractor(s) for Designated and/or Specialty Items, as shown in the Proposal, should attend the preconstruction meeting if such items materially affect the work schedule.

For compliance with threatened and endangered bats, tree clearing must be completed between October 1 and March 31.

Failure by the Contractor to meet interim completion, open to traffic, and/or final completion dates will result in the assessment of liquidated damages in accordance with subsections 108.10.C.1 and 108.10.C.2 of the Standard Specifications for Construction.

Failure by the Contractor to reopen the rail line to rail traffic within the track outage timeframe defined above will result in the assessment of liquidated damages in accordance with the Special Provision for Liquidated Damages for Other Department Costs.

CITY OF ANN ARBOR  
SPECIAL PROVISION  
FOR  
**UTILITY COORDINATION**

BBT:CED

1 of 2

3/12/24

Cooperate and coordinate construction activities with the owners of utilities as stated in subsection 104.08 of the Standard Specifications for Construction. In addition, for the protection of underground utilities, follow the requirements in subsection 107.12 of the Standard Specifications for Construction. Contractor delay claims, resulting from a utility conflict, will be determined based upon subsection 109.05 of the Standard Specifications for Construction.

During the course of construction, the Contractor will encounter both overhead and underground utilities. The names and phone numbers of the utility company representatives will be made available at the pre-construction meeting and shown on the drawings.

For protection of underground utilities and in conformance with Public Act 174, of 2013, as amended, contact "MISS DIG" at 1-800-482-7171 or 811 a minimum of three (3) full working days, excluding Saturdays, Sundays, and holidays prior to beginning each excavation in areas where public utilities have not been previously marked/located. This does not relieve the Contractor of the responsibility of notifying utility owners identified in the contract documents who may not be a part of the "MISS DIG" alert system.

The existing utilities listed below, and shown on the plans, represent the best information available. This information does not relieve the Contractor of the responsibility to be satisfied as to the accuracy and the location of the existing utilities.

NAME OF OWNER	CONTACT INFORMATION	UTILITY TYPE
City of Ann Arbor Utilities 4251 Stone School Rd Ann Arbor, MI 48108	Contacts: Jason McDonald -Water Mark Sirls - Stormwater Travis Conley – Sanitary Sewer Nicholas Jacob - Forestry Mark Moreno, Signs/Signals Phone: 734-794-6350	City Utilities
DTE Electric 1 Energy Plaza Detroit, MI 48226	Contact: Steve McClear Phone: 313-235-4000 Email: <a href="mailto:stephen.mcclear@dteenergy.com">stephen.mcclear@dteenergy.com</a>	Electric
DTE Gas Company 1 Energy Plaza – WCB 1710 Detroit, MI 48226	Contact: Andrew Cairo Phone: 586-291-4265 Email: <a href="mailto:Andrew.cairo@dteenergy.com">Andrew.cairo@dteenergy.com</a>	Gas
AT&T 550 S Maple Rd Ann Arbor, MI 48103	Contact: Michael Jarema Phone: 734-996-5385 Email: <a href="mailto:MJ1749@att.com">MJ1749@att.com</a>	Telephone
Lumen 1025 Eldorado Blvd Broomfield, OH 80021	Contact: David Huckfeldt Phone: 517-812-2592 Email: <a href="mailto:dave.huckfeldt@lumen.com">dave.huckfeldt@lumen.com</a>	Fiber Optic
Railroad Utilities Amtrak Engineering Dept 2330 Brooklyn Rd Jackson, MI 49203	Contact: Ray Weinel Phone: Email: <a href="mailto:wein2535@amtrak.com">wein2535@amtrak.com</a>	Railroad Utilities



CITY OF ANN ARBOR

**COORDINATION CLAUSE  
FOR  
WORK ON RAILROAD PROPERTY**

RAL:PLK

Page 1 of 2

03/21/2024

The following information may be pertinent to the determination of construction methods and railroad protective insurance rates.

**RAILROAD**

**Michigan Line**

Permitting and Insurance:

Contact: Sierra Williams – Permits and Payments Analyst  
Phone: 517-242-7071  
Email: [WilliamsS107@michigan.gov](mailto:WilliamsS107@michigan.gov)  
Address: Michigan Department of Transportation  
425 West Ottawa Street  
PO Box 30050, Lansing, Michigan 48909

Construction:

Contact: William Simmons – ADE – Track & Structure  
Phone: (517) 581-3515  
Email: [William.Simmons@amtrak.com](mailto:William.Simmons@amtrak.com)  
Address: Amtrak (National Railroad Passenger Corporation)  
2330 Brooklyn Road  
Jackson, MI 49203

- Any debris or damage resulting from work shall be immediately reported to the railroad (517-581-3515 or [William.Simmons@amtrak.com](mailto:William.Simmons@amtrak.com)). The railroad shall be repaired by railroad forces at project expense.
- Stormwater must not be directed towards the railroad at any time during construction.
- No staging, construction or loitering on the roadway within the bounds of railroad property.
- All persons that access railroad property under a valid Temporary Permit to Enter (PTE) Upon Property must successfully complete the Contractor Orientation Training. All Contractors must carry their “Amtrak Contractor Roadway Worker Protection” card with them at all times while on or within 50 ft of railroad property.
- Contractor will notify Railroad prior to cutting pavement close to crossing so that the railroad can mark railroad cable. Work around the railroad crossing will be coordinated with Amtrak.

### **TRAIN MOVES**

There are currently no freight trains along this line. Passenger train service is per Amtrak's published schedule.

The train movement and speed information does not represent a commitment by the Railroad and is subject to change without notice.

### **PERCENTAGE OF PROJECT WITHIN RAILROAD RIGHT OF WAY**

Approximately 100 percent of the total work at the structure will be performed over, under, or adjacent to the tracks operated by the railroad.

AMTRAK (MICHIGAN LINE)  
SPECIAL PROVISION  
FOR  
**RAILROAD INSURANCE REQUIREMENTS**  
Temporary Permit to Enter Upon Property  
Maintenance and Repair Contractors

RAL:DGT

1 of 4

APPR:JLD:SMR: 08-01-2021

**a. Description.** This work consists of providing Railroad Protective Liability Insurance before work is commenced and kept in effect until all work required to be performed under the terms of the contract is satisfactorily completed as evidenced by the formal acceptance by the Michigan Department of Transportation (Department).

**b. Insurance Requirements.** Carry the following insurance, in a form, and with an insurer or insurers, acceptable to the Department, National Railroad Passenger Corporation (Amtrak), and Norfolk Southern Railway Company hereinafter referred to as the Railroads as noted in the Coordination Clause for Work on Railroad Property.

1. Railroad Protective Liability Insurance (RRL) in behalf of the following as the named insureds:
  - A. National Railroad Passenger Corporation (Amtrak)
  - B. Norfolk Southern Railway Company

The Contractor must furnish to the Department and to the Railroads copies of policies as evidence that, with respect to Contractor and, if applicable, subcontractor operations, standard Railroad Protective Liability Insurance is carried providing for limits of liability in the amount of two million dollars (\$2,000,000) combined single limit per occurrence for bodily injury, death, and property damage with an aggregate limit six million dollars (\$6,000,000) applying separately to each annual period. Said Railroad Protective Liability Insurance must conform to the regulations prescribed therefore in the Federal-Aid Policy Guide, Part 646, Subpart A of the Federal Highway Administration dated December 9, 1991, and amendments thereto.

Further, "Physical Damage to Property" as defined in the policy is to be deleted and replaced by the following endorsement:

"It is agreed that 'Physical Damage to Property' means direct and accidental loss of or damage to all property owned by any named insured and all property in any named insured's care, custody and control."

In the alternative, and upon Amtrak's approval, Contractor may elect to have Amtrak insure the Operations under its Blanket RRP Liability Insurance Program. The premium, which shall be determined by the rate schedule promulgated by the insurer in effect as of the effective date of the Agreement, shall be prepaid by Contractor and included in other items of work. In the event Contractor and Amtrak agree to insure the operations on railroad property under Amtrak's RRP Program, Contractor shall include the RRP premium in addition to the Permit Fee.

The original RRP Liability Insurance Policy must be submitted to Amtrak prior to

commencement of Operations. The Contractor must furnish to the Department evidence of any reductions in the limits of liability hereinabove described as determined by the Railroads.

Each policy must contain the following endorsement:

"It is hereby agreed that 30 days prior written notice of cancellation, expiration, termination, or reduction of coverage provided by this policy will be given to all below entities:

- A. National Railroad Passenger Corporation (Amtrak)
- B. Norfolk Southern Railway Company
- C. The State of Michigan, the Michigan State Transportation Commission, the Michigan Department of Transportation and its employees.

2. Provide insurance as required in subsection 107.10 of the Standard Specifications for Construction except with the modifications stated herein.

A. Workers' Compensation Insurance complying with the requirements of the statutes of the jurisdiction(s) in which the Operations will be performed, covering all employees of Contractor. Employer's Liability coverage with limits of not less than \$1 million each accident or illness shall be included.

In the event the Operations are to be performed on, over, or adjacent to navigable waterways, a U.S. Longshoremen and Harbor Workers' Compensation Act Endorsement and Outer Continental Lands Act Endorsement are required.

B. Commercial General Liability (CGL) Insurance covering liability of Contractor with respect to all operations to be performed and all obligations assumed by Contractor under the terms of the Agreement. Products-completed operations, independent contractors and contractual liability coverages are to be included, with the contractual exclusion related to construction/demolition activity within fifty (50) feet of the railroad deleted and no exclusions for Explosion/Collapse/Underground (X-C-U) applicable or added.

The policy shall name the State, National Railroad Passenger Corporation, as appropriate Washington Terminal Company (WTC), and all commuter agencies and railroads that operate over the property or tracks at issue as additional insureds with respect to the operations to be performed. In addition, the policy shall include an ISO endorsement Form CG 24 17 10 01 or its equivalent providing contractual liability coverage for railroads listed as additional insureds. Coverage for such additional insureds shall be primary and non-contributory as respects any other insurance the additional insureds carry. Coverage under this policy shall have limits of liability of not less than \$2 million each occurrence, combined single limit, for bodily injury (including disease or death), personal injury and property damage (including loss of use) liability. Such coverage may be provided by a combination of a primary CGL policy and a following form excess or umbrella liability policy.

C. Automobile Liability Insurance covering the liability of Contractor arising out of the use of any vehicles which bear, or are required to bear, license plates according to the laws of the jurisdiction in which they are to be operated, and which are not covered under Contractor's Commercial General Liability insurance. The policy shall name the

State, National Railroad Passenger Corporation, as appropriate WTC, and all commuter agencies and railroads that operate over the property or tracks at issue as additional insureds with respect to the operations to be performed. Coverage under this policy shall have limits of liability of not less than \$2 million each occurrence, combined single limit, for bodily injury and property damage (including loss of use) liability.

In the event Contractor or any subcontractor will be transporting and/or disposing of any hazardous material or waste off of the jobsite, a MCS-90 Endorsement is to be added to this policy and the limits of liability are to be increased to \$5 million each occurrence.

D. All Risk Property Insurance covering physical loss or damage to all property used in the performance of the Operations on a full replacement cost basis. The policy shall have limits of liability adequate to cover all property of Contractor (including personal property of others in Contractor's care, custody or control).

E. Contractor's Pollution Liability Insurance covering the liability of Contractor arising out of any sudden and/or non-sudden pollution or impairment of the environment, including clean-up costs and defense, that arise from the Operations of Contractor with the State, National Railroad Passenger Corporation, as appropriate WTC, and all commuter agencies and railroads that operate over the property or tracks at issue named as additional insureds. Coverage under this policy shall have limits of liability of not less than \$2 million each occurrence. The coverage shall be maintained during the term of the project, and for at least two (2) years following Amtrak acceptance of the completion of all Operations to be performed.

F. Pollution Legal Liability Insurance is required if any hazardous material or waste is to be transported or disposed of off the jobsite. Contractor, its subcontractor or transporter, as well as the disposal site operator, shall maintain this insurance. Contractor shall designate the disposal site and must provide a certificate of insurance from the disposal facility to Amtrak. The policy shall name the State, National Railroad Passenger Corporation, as appropriate WTC, and all commuter agencies and railroads that operate over the property or tracks at issue as additional insureds, with limits of liability of not less than \$2 million per claim.

Further, any additional insurance coverages, permits, licenses and other forms of documentation required by the United States Department of Transportation, the Environmental Protection Agency and/or related state and local laws, rules and regulations shall be obtained by Contractor.

G. Professional Liability Insurance covering the liability of Contractor for any and all errors or omissions committed by Contractor in the performance of the Operations, regardless of the type of damages. The coverage shall be maintained during the term of the Operations, and for at least three (3) years following completion thereof. The policy shall have limits of liability of not less than \$2 million per claim and in the annual aggregate. The policy may contain a deductible of a maximum of two hundred fifty thousand dollars (\$250,000), but in such case the deductible is the sole responsibility of Contractor, and no portion of such deductible is the responsibility of Amtrak.

If Contractor is not performing professional design or engineering services, Contractor may elect to satisfy this requirement through the addition of endorsement CG2279 "Incidental Professional Liability" to its CGL policy.

H. Waiver of Subrogation As to all insurance policies required herein, Contractor waives all rights of recovery, and its insurers must waive all rights of subrogation of damages against the State, Amtrak, as appropriate WTC, and their agents, officers, directors, and employees. The waiver must be stated on the certificate of insurance.

I. Punitive Damages Where allowed by law, no liability insurance policies required above shall include an exclusion for punitive or exemplary damages, including but not limited to CGL insurance and Railroad Protective Liability insurance.

J. Claims-Made Insurance If any liability insurance specified above shall be provided on a claims-made basis, then in addition to coverage requirements above, such policy shall provide that:

1. The retroactive date shall coincide with or precede Contractor's start of Operations (including subsequent policies purchased as renewals or replacements);

2. The policy shall allow for the reporting of circumstances or incidents that might give rise to future claims;

3. Contractor will use its best efforts to maintain similar insurance under the same terms and conditions that describe each type of policy listed above (e.g., Commercial General Liability, Professional Liability) for at least three (3) years following completion of the Operations; and

4. If insurance is terminated for any reason, Contractor will purchase an extended reporting provision of at least two (2) years to report claims arising from Operations.

K. Evidence of Insurance Contractor shall furnish evidence of insurance as specified above at least fifteen (15) days prior to commencing Operations. Prior to the cancellation, renewal, or expiration of any insurance policy specified above, Contractor shall furnish evidence of insurance replacing the cancelled or expired policies. THESE DOCUMENTS SHALL INCLUDE A DESCRIPTION OF THE Project AND THE LOCATION ALONG THE RAILROAD RIGHT-OF-WAY (typically given by milepost designation) IN ORDER TO FACILITATE PROCESSING. The fifteen (15) day advance notice of coverage may be waived by Amtrak in situations where such waiver will benefit Amtrak, but under no circumstances will Contractor begin Operations without providing satisfactory evidence of insurance as approved by Amtrak. Such evidence of insurance coverage shall be sent to:

Senior Manager Engineering  
National Railroad Passenger Corporation  
2955 Market Street  
30th Street Station, Mail Box 64  
Philadelphia, PA 19104-2817

**c. Construction.** If any of the insurance is canceled, the Contractor and all subcontractors must cease operations as of the date of cancellation and cannot resume operations until new insurance is in force.

**d. Measurement and Payment.** The Contractor must pay for all railroad insurance. Insurance costs as described in this special provision will be included as part of other pay items.

CITY OF ANN ARBOR  
SPECIAL PROVISION  
FOR  
**RAILROAD INSPECTION AND FLAGGING**

BBT:CED

1 of 1

4/11/24

**a. Description.** This work consists of providing advance notice to a representative of the Amtrak (National Railroad Passenger Corporation) (herein after called the Railroad) and the Engineer meeting the railroad notice requirements found in the contract for providing flaggers for work on, above, or below Railroad property.

**b. Materials.** None specified.

**c. Construction.** Ensure construction methods are in compliance with the requirements in the contract.

Plan operations to limit the number of days requiring railroad flagging. A total of 53 days has been budgeted for the entire construction in which railroad flagging will be required. Provide an estimated number of flagging days anticipated to the Engineer prior to beginning work. If the number of days noted above is exceeded and the Contractor has not received a documented extension of time for delays that have caused additional flagging costs, the Contractor shall pay for these additional flagging costs in addition to any liquidated damages on the contract.

The Contractor is to reference and comply with all applicable Railroad special provisions and requirements. The items detailed in this special provision will also be required and will take precedence over the Railroad requirements if there is conflicting information.

Provide the Railroad a documented notice 5 calendar days in advance when flagging is no longer needed, with a copy to the Engineer and retain a copy of this documented notification. If the notification to the Railroad is not at least 5 calendar days in advance of no longer needing flagging, the Railroad will schedule, and the Contractor must pay such flagging services until said cancellation notice is confirmed by the Railroad.

**d. Measurement and Payment.** The coordination and documentation as described in this special provision will not be paid for separately but is considered incidental to the project. Flagging costs will be paid to the railroad directly by the City of Ann Arbor.



MICHIGAN  
DEPARTMENT OF TRANSPORTATION  
  
SPECIAL PROVISION  
FOR  
**WORK ON RAILROAD PROPERTY, AMTRAK**

RAL:PLK

1 of 4

APPR:JYG:CRB:04-11-23

**a. Description.** This special provision provides the requirements that the Contractor must meet when doing work on, above, or below railroad property.

**b. Materials.** None specified.

**c. Construction.**

1. Cooperate with public utility, railroad and other organizations having occasion to carry on their usual work within the limits of the project or doing work on and in connection with the project.

2. Conduct the work without damage to the property of, or in care of, and insofar as is possible, without delay to the trains operating on the tracks of, or in care of, the National Railroad Passenger Corporation (Amtrak), hereinafter referred to as the Railroad. Observe such restrictions as received from both the Engineer and the Railroad's Chief Engineer or authorized representative on the project site, that may be imposed for the safety and dispatch of persons and property of and in care of the Railroad and for the safe and expeditious operation of its trains. If direction or restrictions are received directly from the Railroad's authorized representative, ensure to notify the Engineer of the direction or restriction. Claims will not be considered due to hindrance or delay on account of Railroad traffic, any work done by the Railroad, or other delay incident to or necessary for safe maintenance of Railroad traffic or for any delays due to compliance with this special provision.

3. Provide protection from falling debris to the property, track, and rail traffic of the Railroad, in accordance with the Railroad's specifications (including the *AREMA Manual for Railway Engineering*) and the contract. Ensure any such protection is constructed no lower than 22 feet vertically from the top of the rail.

4. Obtain documented approval from the Railroad and the Engineer at least 30 calendar days before starting work, of the proposed construction and demolition methods, schedule of operations, debris protection and horizontal and vertical clearances over and adjacent to the track of, or in care of, the Railroad to be provided during the construction period. Approval will be based on the specifications of the Railroad (including *AREMA*). Contact the Railroad's local representative to coordinate approval of a site-specific work plan addressing the above items. All approvals will not relieve the Contractor of any responsibility for the adequacy and safety of the construction. Submit to the Railroad with a copy to the Engineer a documented safety program prepared by the Contractor for the education and protection of employees working on this project. This program must address the hazards and safety considerations of working in the vicinity of the Railroad's operations and property.

5. Provide documented notification to the Railroad with a copy to the Engineer a minimum

of 30 calendar days before entering upon the property of, or in care of, the Railroad or starting any work which may require flag protection by the Railroad. Flagging arrangements must be in place and pre-paid by the Contractor directly to the Railroad before work can begin on, above, or below the property of, or in care of, the Railroad. Work will be stopped if notification is not received timely. Work stoppages due to improper notification to the Railroad will not be considered for compensation or time extensions. Arranging for a Railroad flagger will be paid for as described in the Special Provision for Inspection and Flagging.

6. Do not use railroad property without written permission of the Railroad. Leave railroad roadbed and property in a condition acceptable to the Railroad. Contact the Railroad to request the "Temporary Permit to Enter Upon Amtrak Property". The costs billed by the Railroad to the Contractor for agreements, permits, licenses, and approvals required by the Railroad or the Engineer, will be paid by the Contractor, and will be included in the pay item for Railroad Protection, Amtrak as described herein. Costs attributed to the time and engineering effort invested by the Contractor and any subcontractors in obtaining Railroad documents and approvals are not included in the Railroad Protection, Amtrak pay item, but are included in other bid items of work and will not be paid for separately. The time for the Railroad to respond to the initial permit request is approximately 30 calendar days, and subsequent submittals to the Railroad will require similar response times. Several submittals may be required before the Railroad issues the "Temporary Permit to Enter Upon Amtrak Property." The Contractor must take this into consideration when planning its operations schedule.

7. Nothing in this special provision, nor approval by the Railroad as to construction operations, relieves the Contractor of any responsibility or liability.

8. Pay the Railroad or owning company for any changes to railroad property, facilities, or to wire and pipe lines, required for the Contractor's convenience, other than as shown on the plans for the project.

9. Provide at least 12 weeks advance documented notice to the Railroad with a copy to the Engineer of any requests for temporary crossings of railroad tracks. Approval of temporary crossings are not guaranteed. It is the responsibility of the Contractor to determine and comply with the requirements of the Railroad covering the location, installation, protection, maintenance, use, and removal of such an approved temporary crossing. An agreement between the Contractor and Railroad covering the temporary crossing will be required. The Contractor will bear all costs and expenses incidental thereto, including, but not limited to, the cost of installation, protection, maintenance, and removal of such temporary crossing, contractual liability and other insurance specific to the temporary crossing as required by the Railroad, and incidental work such as agreement preparation and fees, drainage facilities and removal, alteration, and replacement of railroad fences.

10. Conduct all construction operations and provide measures as detailed on the plans to protect the Railroad track ballast and/or track structure from being contaminated by foreign materials (fouled). Shop drawings of these measures must be documented and submitted for review and approval by the Railroad and the Engineer prior to installation. Costs for shop drawing preparation and Railroad and Engineer approvals are not included in the Railroad Protection, Amtrak pay item, but are included in other bid items of work and will not be paid for separately. This review and approval of shop drawings may take 30 calendar days minimum for each submittal and multiple submittals may be required before approval may be received. Installation may not begin until documented approval of the shop drawings has

been received. These protective measures must remain in place until the authorized representative of the Railroad approves their removal. The costs for these protective measures will be paid for in accordance with the contract. Modifications may be required of the protective measures detailed on the plans if they do not appear by the Railroad or Engineer to completely protect the Railroad structures during construction. These changes will be paid for in accordance with section 109.05 of the Standard Specifications for Construction. If Railroad track ballast does become fouled, the Railroad may with its own forces, remove the fouled ballast and replace it with clean ballast. The charges for this work will be billed by the Railroad to the Contractor who must pay them within 14 calendar days of receiving the invoice. Costs to replace fouled ballast with clean ballast are not included in the Railroad Protection, Amtrak pay item, but are included in other bid items of work and will not be paid for separately.

If the Contractor desires to modify the protective measures as detailed on the plans for the convenience of the construction of the project, then the Contractor must submit shop drawings showing the modified protection measures to the Railroad and the Engineer and receive documented approval before beginning any installation. This review and approval of shop drawings may take 30 calendar days minimum for each submittal and multiple submittals may be required before approval may be granted. Modifications of the protective measures may or may not be acceptable to the Railroad and the Engineer. No extension of time will be approved for delays caused by the submission of modified protection measures. If approved, these protective measures must be performed by, and at the expense of, the Contractor and under the supervision of, and to the satisfaction of, the Railroad's authorized representative and the Engineer; but the Railroad assumes no responsibility for the adequacy thereof. These protective measures must remain in place until the authorized representative of the Railroad approves their removal.

11. Maintain temporary minimum construction clearances of 22 feet vertically from top of rail and 15 feet horizontally from and measured at right angles to the centerline of the active track for the erection of any necessary falsework, bracing, or forms. The Railroad may require temporary clearances greater than specified above if the specific site conditions permit. Exceptions to these clearances require advance approval from the Railroad. Exceptions will be clearly shown on the plans.

12. Comply with Railroad safety rules that require, without exception, hard hat, eye protection, high-visibility orange colored reflective vest, and safety shoes be worn while working on structures over or under the tracks of the Railroad. The Contractor and any subcontractor employees must attend a Railroad safety training class held by the Railroad prior to beginning work on, over, or adjacent to Railroad property. This class is provided electronically at the website [www.amtrakcontractor.com](http://www.amtrakcontractor.com). If any personnel change, Amtrak requires the new personnel to also take the class. All costs associated with these Railroad safety training requirements and documentation are to be paid by the Contractor and will not be paid for separately but are included in other bid items of work. The Railroad may require Contractor's employees and subcontractors to attend daily job briefings (anticipated to be about 15 minutes duration); costs (including time of employees and subcontractors) associated with these briefings are to be paid by the Contractor and will not be paid for separately but are included in other bid items of work.

13. Acceptance of work by the Engineer under this contract involving the Railroad will be conditioned upon approval of the Railroad's authorized representative.

14. In addition to the requirements listed above, the Contractor must observe and follow the "Maintenance and Protection of Railroad Traffic During Contractor Operations - EP3014," and other documents (see list of documents in the RID folder of ProjectWise), available from the Railroad.

15. The Contractor and/or any subcontractor(s) must defend, indemnify, protect and hold harmless Railroad and its officers, agents and employees from and against any and all suits, demands, claims, loss, damage, charges or expense, whether direct or indirect, to which they may be subjected by reason of any damage, loss or injury to persons or property caused by or resulting from any wrongful act or neglect by the Contractor or subcontractor(s) in the performance of any work related to the project.

**d. Measurement and Payment.** Review the accuracy of costs as billed by the Railroad and resolve any inconsistencies prior to submitting a reimbursement request to the Engineer. Submit satisfactory evidence to the Engineer indicating all invoices for protective services and devices furnished by the Railroad have been fully paid.

The Engineer will reimburse the Contractor for the costs incurred that have satisfactory evidence of payment to the Railroad using the following pay item.

<b>Pay Item</b>	<b>Pay Unit</b>
Railroad Protection, Amtrak.....	Dollar

**Railroad Protection, Amtrak** includes only the following:

1. Any modifications made to the protection details supplied on the plans made at the request of the Railroad,
2. Providing Railroad employees on-site access to sanitation facilities per subsection 107.05 of the Standard Specifications for Construction, near location of Railroad flagger's work station,
3. Any costs billed by the Railroad for agreements, permits, and approvals required by the Railroad or the Engineer. Costs attributed to the time and engineering effort invested by the Contractor and subcontractors in obtaining Railroad documents and Railroad and Engineer approvals are not included in the Railroad Protection, Amtrak pay item, but are included in other bid items of work and will not be paid for separately.

All other costs in complying with the requirements in this special provision and of the Railroad are included in other bid items of work and will not be paid for separately.

CITY OF ANN ARBOR  
SPECIAL PROVISION  
FOR  
**CLEARING, MODIFIED**

BBT:CED

1 of 1

3/12/24

**a. Description.** This work consists of clearing in areas without a proposed shared use path. This work shall be done in accordance with sections 201 of the Standard Specifications for Construction, except as herein provided.

**b. Materials.** All work must be in accordance with the contract documents.

**c. Construction.** Remove trees less than 6-inches in diameter, within 18-inches of existing ground. Existing stumps, or stumps generated from previous tree removals must be removed by the Contractor. The removal limits shall extend to the proposed grading limit line and include other areas designated on the plans. Fell trees without danger to traffic or injury to other trees, structures or property. Do not remove trees until verified by the Engineer.

**d. Measurement and Payment.** The completed work, as described, will be measured and paid for at the contract price using the following pay items:

<b>Pay Item</b>	<b>Pay Unit</b>
Clearing, Modified.....	Acre

**Clearing, Modified** included the work described. Removal of stumps, either existing or from cut trees in this Contract will not be paid for separately.

MICHIGAN  
DEPARTMENT OF TRANSPORTATION

SPECIAL PROVISION  
FOR  
VERTICAL EXPLORATORY INVESTIGATION FOR RELOCATION

COS:MRB

1 of 2

APPR:DMG:NAL:04-30-20  
FHWA:APPR:05-06-20

**a. Description.** When proposed work must be relocated as directed by the Engineer, this special provision is used to compensate the Contractor to locate and expose underground infrastructure and obstructions, such as culverts, sewers and utilities. Perform this work only when conflicts are found in the planned work location. This special provision is not to compensate for the Contractor's responsibilities in subsection 107.12 of the Standard Specifications for Construction.

**b. Materials.** Use Granular Material Class III in accordance with section 902 of the Standard Specifications for Construction for backfill. Use material removed during exploratory investigation for backfill only if approved by the Engineer.

**c. Construction.** The owner of any sewer or utility to be exposed will not take the facilities out of service during the exploratory investigation. Contact utility owners in accordance with subsection 107.12 of the Standard Specifications for Construction.

Advance the exploratory excavation using vacuum excavation, hand digging, conventional machine excavation, or a combination thereof subject to approval of the Engineer. Allow the Engineer access to document the necessary information. If the technique used to advance the excavation causes any damage to the existing facilities, immediately contact the utility owner and cease all work until an alternate method is approved by the Engineer.

Take care to protect the exposed culvert, sewer or utility from damage during construction. The Contractor is responsible for all costs associated with the repair work and out of service time of all broken or damaged existing culverts, sewers or utilities as a result of any action by the Contractor. If the exploratory investigation results in damage to utilities, contact the owner of such utility to coordinate the repair. Repair or replace culvert, sewer or utility, damaged during exploratory excavation, in accordance with the standard specifications and as approved by the Engineer.

Obtain the Engineer's approval before backfilling the excavation. Complete backfilling no later than 24 hours after approval has been given. Backfill in accordance with subsection 204.03.C of the Standard Specifications for Construction. Dispose of excess material in accordance with the standard specifications.

**d. Measurement and Payment.** The completed work, as described, will be measured and paid for at the contract unit price using the following pay item:

<b>Pay Item</b>	<b>Pay Unit</b>
Exploratory Investigation, Vertical.....	Foot

**Exploratory Investigation, Vertical** will be measured by the foot from top of existing grade vertically to the bottom of the excavation for up to a 4-foot maximum diameter hole, or as approved by the Engineer. The excavated depth of each 4-foot maximum diameter hole will be measured separately for payment.

**Exploratory Investigation, Vertical** includes all costs associated with repair or replacement resulting from the Contractor's activities. Providing necessary lane, shoulder and/or sidewalk closures required to perform work will be paid for by other associated items in the contract. Restoration work will be paid for by other associated items.

MICHIGAN  
DEPARTMENT OF TRANSPORTATION

SPECIAL PROVISION  
FOR  
**NON-HAZARDOUS CONTAMINATED MATERIAL HANDLING AND DISPOSAL**

ENV:JCW

1 of 2

APPR:DMG:DBP:02-26-20  
FHWA:APPR:03-02-20

**a. Description.** This work consists of handling, transporting, disposing of non-hazardous contaminated material, including all laboratory testing required for the proper disposal of the material and site restoration of temporary storage locations. Ensure this special provision is not employed without authorization by the Engineer. The laboratory testing will be used to solicit landfill approval and is not intended to determine whether or not the material is contaminated. Soil delineated on the plans and classified as non-hazardous contaminated cannot be used elsewhere on the project regardless of the laboratory test results unless otherwise directed by the Engineer.

**b. Materials.** None specified.

**c. Construction.** Complete this work in accordance with sections 204 and 205 of the Standard Specifications for Construction, except as modified herein or as directed by the Engineer.

1. Excavation of Non-hazardous Contaminated Material. Excavate non-hazardous contaminated material as shown on the plans or as directed by the Engineer.

2. Temporary Storage of Non-hazardous Contaminated Material. Place excavated non-hazardous contaminated material which is to be temporarily stockpiled on plastic sheeting or tarps having a minimum thickness of 6 mils or in trucks, roll off boxes, or other containers, such that no liquid may escape from the containment. Cover the non-hazardous contaminated material securely with plastic sheeting of 6 mils thickness or greater at the end of each work day.

Dispose of excavated non-hazardous contaminated material as soon as approval is received from the disposal site. This material cannot be stockpiled for longer than 30 days prior to disposal.

Restore temporary storage locations to the condition prior to conducting the work.

3. Sampling and Analysis of Non-hazardous Contaminated Material. Sample and analyze non-hazardous contaminated material prior to disposal. The analysis required is dictated by the Type II disposal facility to be utilized for disposal. Should the results of the analysis show the material to be hazardous waste, as defined by the 1994 PA 451, Part 111, of the Natural Resources and Environmental Protection Act, notify the Engineer immediately. The material must then be disposed of as directed by the Engineer.

4. Disposal of Non-hazardous Contaminated Material. Dispose of non-hazardous contaminated material at a licensed Type II sanitary landfill. Submit at the preconstruction



meeting the name of the Type II landfill to be used for disposal, the sampling and analysis requirements of that landfill, and verification that use of the proposed landfill will meet the requirements of the county solid waste plan.

Ensure the proposed landfill is acceptable to the Department and approval is obtained from the Engineer prior to commencing disposal operations. Provide a copy of the laboratory analysis to the Engineer as a requirement of approval for disposal. Following disposal and prior to approval for payment provide to the Engineer landfill receipts for all non-hazardous contaminated material disposed of.

**d. Measurement and Payment.** The completed work, as described, will be measured and paid for at the contract unit price using the following pay item:

<b>Pay Item</b>	<b>Pay Unit</b>
Non Haz Contaminated Material Handling and Disposal, LM.....	Cubic Yard

**Non Haz Contaminated Material Handling and Disposal, LM** will be measured by volume in cubic yards, LM. Provide to the Engineer receipts from the disposal facility for the number of cubic yards disposed of at that facility prior to payment. Payment will include all costs for materials, labor and equipment needed for storage, loading, transportation, testing, restoration of temporary storage locations and disposal of the non-hazardous contaminated material. Disposal costs will include all documentation required by the landfill.

Payment for excavation of non-hazardous contaminated material will be included with the related items of work.

Delays in testing and disposal of non-hazardous contaminated material that are not the fault of the Contractor may be considered valid reasons for extension of time. However, these delays and the resultant extensions of time will not be considered valid reasons for additional payment.

Should the analysis of the material document that it is hazardous waste, then payment for disposal of hazardous waste will be measured and paid for as extra work. Disposal includes hauling by a licensed hazardous waste hauler and disposal at an appropriate licensed disposal facility. Prequalification is waived.

CITY OF ANN ARBOR  
SPECIAL PROVISION  
FOR  
**DEWATERING SYSTEM, EXCAVATION**

BBT:CED

1 of 3

3/20/2024

**a. Description.** This work consists of lowering the groundwater table to facilitate the excavation. This work will require the use of pumps or well points, deep wells, or other measures that are utilized to control and manage groundwater.

**b. Well Points and Deep Wells.** Ensure groundwater control performed by deep well and/or well point pumping systems is done without damage to property or structures and without interference with the rights of the public, owners of private property, pedestrians, vehicular traffic or the work of other contractors. Any pumping methods used for dewatering and control of groundwater and seepage must have properly designed filters to ensure that adjacent soil will not be pumped with the water, thus creating voids underground and around the face of the excavation or under existing structures. Ensure the loss of fines is limited to no more than 5 parts per million by volume in the extracted water. Ensure the filter design is reviewed and approved by the Engineer before placement.

Perform the dewatering operations in a proper and predetermined sequence with the excavation operation such that the perimeter, bottom and face of the excavation are stable. Dewatering well diameter, pumping rate and well spacing must provide adequate drawdown of the water level. Properly locate wells to intercept groundwater that otherwise would enter the excavation and interfere with the work. Install observation wells at key locations for observation of groundwater levels during the excavation. Submit a plan for locations and monitoring frequency of the observation wells to the Engineer a minimum of 7 calendar days in advance of placement of the dewatering system. Add additional wells as needed to dewater to the groundwater to the elevation shown on the plans.

Filters or settling devices may be required before discharge to ensure that storm sewers, sanitary sewer systems or surface waters are not adversely affected by construction debris or increased sediment load.

Artesian conditions exist in the area. Do not install wells deeper than elevation 760.00.

**c. Storm Sewer, Sanitary Sewer or Surface Water Discharge.** The groundwater was sampled and tested in April 2022 which yielded no dioxane contamination, however, additional testing was not performed. Test the groundwater after installation of the system and if found to be contaminated, notify the Engineer immediately.

Monitor the volume of water discharged to the storm sewer system, sanitary sewer system or as surface water discharge by using a totalizing turbine type flow meter. Place the flow meter in-line on the dewatering system effluent line, ensure it is designed for high flow applications and has a flow totalizing register that is adequately sealed to eliminate fogging and condensation. Install the type of meter used in accordance with the manufacturer's instructions and be approved by the Engineer before placement.

Written permission from the wastewater treatment plant authority is required prior to discharge to the sanitary sewer system. Provide a copy of the written authorization to the Engineer prior to discharging any water to the system.

Secure a NPDES permit from Environment, Great Lakes, and Energy (EGLE) prior to any discharge to a storm sewer or directly to a surface water body.

Monitor and document the volume of flow being discharged to the storm sewer, sanitary sewer or the surface water daily by reading the register on the flow meter. Provide this information to the Engineer daily or as otherwise approved.

**d. Construction.** Lower the groundwater to the elevation shown on the plans. Determine the methods and materials required to accomplish this work, subject to approval by the Engineer before initiation or installation of the dewatering system.

The Engineer may order corrective actions to the dewatering system at any time due to deficiencies in the system at no additional cost to the contract.

Remove dewatering system and all associated appurtenances when no longer needed and restore the area as directed by the Engineer.

Abandon deep wells and observation wells in accordance with current EGLE requirements when no longer needed.

Do not extend wells below elevation 760.00. Artesian conditions are known to exist. Corrective actions to address artesian conditions caused by penetrating below the known bottom of clay layer as shown on the soil borings will be completed at no cost to the Department.

**e. Measurement and Payment.** The completed work, as described, will be measured and paid for at the contract unit price using the following pay item:

<b>Pay Item</b>	<b>Pay Unit</b>
Dewatering System, Excavation .....	Lump Sum

**Dewatering System, Excavation** includes all labor, equipment, materials, wells, piping, supplies, power, and fuel necessary for the installation, operation, maintenance, removal and the disposal of all surplus materials as described herein. This pay item includes the cost of disposal of all water pumped from below ground to facilitate underground construction regardless of the number of stages or duration required to complete the work.

All costs associated with obtaining an NPDES permit and any locally required permits are included in **Dewatering System, Excavation**.

The installation, maintenance and removal of deep wells and observation wells are included in **Dewatering System, Excavation**.

The cost for treatment of the water at the wastewater treatment plant is included with **Dewatering System, Excavation**. There will be no compensation for idled personnel or equipment due to any system corrections ordered by the Engineer to remedy any deficiencies.

If water is found to be contaminated, additional costs will be paid for in **Dewatering System for Contaminated Groundwater, Site.**

MICHIGAN  
DEPARTMENT OF TRANSPORTATION

SPECIAL PROVISION  
FOR  
EROSION CONTROL, INLET PROTECTION, FABRIC DROP

COS:DMG

1 of 2

APPR:TWK:CP:03-11-20  
FHWA:APPR:03-13-20

**a. Description.** This work consists of furnishing and installing acceptable alternatives to inlet protection devices (devices) listed in the *Soil Erosion and Sedimentation Control Manual* when the pay item Erosion Control, Inlet Protection, Fabric Drop is included in the contract.

This work consists of furnishing, installing, maintaining, disposing of collected material and removing devices at the locations shown on the plans or as directed by the Engineer.

**b. Materials.** The following devices are approved for use as acceptable alternatives:

1. Siltsack Type B, Regular Flow, by ACF Environmental, Inc.
2. Inlet Pro Sediment Bag, Standard Flow, with optional foam deflector by Hanes Geo Components.
3. Dandy Curb Bag, Dandy Bag, Dandy Curb Sack, Dandy Sack, or Dandy Pop by Dandy Products, Inc.
4. Basin Bag, Regular Flow by CSI Geoturf.
5. Flexstorm Catch-It and Flexstorm Pure used with filter bag types FX, FX+, FXO, PC, PC+ or IL.

Ensure provided devices are sized appropriately for the drainage structures in which they will be installed.

**c. Construction.** Install, maintain and remove the devices in accordance with the manufacturer's guidelines. Remove material collected by the devices in accordance with the manufacturer's guidelines or as directed by the Engineer.

Dispose of collected material in accordance with subsection 205.03.P of the Standard Specifications for Construction. Those devices that are no longer needed and have been removed may be reused elsewhere on the project as approved by the Engineer.

**d. Measurement and Payment.** The completed work, as described, will be measured and paid for at the contract unit price using the following pay item:

<b>Pay Item</b>	<b>Pay Unit</b>
Erosion Control, Inlet Protection, Fabric Drop.....	Each

**Erosion Control, Inlet Protection, Fabric Drop** will be paid for as one each for each time the alternate device listed herein is installed, maintained, and removed at a separate location within the project limits.

CITY OF ANN ARBOR  
SPECIAL PROVISION  
FOR  
**CULVERT, PRECAST CONCRETE BOX, MODIFIED**

BBT:CED

1 of 2

3/7/24

**a. Description.** This work consists of designing, load rating, manufacturing, and installing precast concrete box culvert segments with galvanized metal tie rods, plate washers, lock washers, and acceptable soil and watertight sealant as filler to access holes on the final three section/2 joints of box culverts as shown on the plans, this specification, and according to the current (as of bid letting date for this project) *American Railway Engineering and Maintenance-of-Way Association* (AREMA) specifications, Cooper E80 loading and section 406 of the Standard Specification for Construction.

Do not manufacture the precast concrete elements on the jobsite. All precast elements must be manufactured at a commercial precast plant listed in subsection 909.04 of the Approved Manufacturers section of MDOT's Materials Source Guide.

**b. Materials.** Provide materials in accordance with subsection 406.02 of the Standard Specifications for Construction.

Provide the following materials to construct the joint tie assemblies:

1. One inch diameter threaded rods meeting the requirements of ASTM F1554, Grade 36.
2. Two inch by two inch by 5/16 inch plate washers meeting the requirements of ASTM A36/A36M.
3. Flat circular washers meeting the requirements of ASTM F436/F436M to be placed over the plate washer and under the lock washer.
4. Lock washers meeting the requirements of ANSI B18.21.1.
5. Heavy hex nuts meeting the requirements of ASMT A563, Grade A.
6. Select and apply watertight and soil tight hole filler in accordance with subsection 713.02.B of the Standard Specifications for Construction.

Ensure all hardware is galvanized in accordance with ASTM A123/A123M or ASTM A153/A153M, as applicable.

Provide PVC liner for the culvert joints that is 30 mils thick. Use resins to manufacture the PVC liner that are 100 percent first quality virgin PVC. Ensure the PVC liner is resistant to UV degradation, construction damage and all forms of biological and chemical degradation normally encountered in highway construction applications. Satisfy the physical properties contained in Table 1.

**Table 1: PVC Liner Physical Requirements**

Property	Test Method	Requirement
Thickness Tolerance	ASTM D1593	+/- 5 percent
100 Percent Modulus	ASTM D882	1000 psi (minimum)
Elongation @ Break	ASTM D882	300 percent (minimum)
Dimensional Stability	ASTM D1204 (212 degrees F, 15 minutes)	5 percent change (maximum)

Provide test data certification from the manufacturer with each material shipment, which includes a certified report of quality control test results obtained from the lot(s) of material in the shipment. Label each unit of material to provide product identification sufficient for field identification and correlation to certified test results. Certify the specified physical properties as minimum average roll values (MARV).

**c. Construction.** Design and load rate precast box culverts in accordance with current AREMA specifications and Cooper E80 loading and provide calculations to the Engineer for review that are sealed by a Professional Engineer in the State of Michigan. All other construction methods must be in accordance with subsection 406.03 of the Standard Specifications for Construction.

Install and maintain joint tie assemblies and hole filler during construction and backfilling activities. Use caution when placing and compacting backfill materials adjacent to the assemblies. Ensure damage to the joint tie assemblies or box culvert around the assemblies caused by the Contractor’s operation is repaired or replaced at the Contractor’s expense.

Joint tie assemblies are intended to hold the box culvert sections in place throughout the design life and must not be used to pull the sections together during construction.

Apply tie rod hole filler in accordance with subsection 713.03.F of the Standard Specifications for Construction.

**d. Measurement and Payment.** The completed work, as described, will be measured and paid for at the contract unit price using the following pay items:

<b>Pay Item</b>	<b>Pay Unit</b>
Culv, Precast Conc Box, __ foot by __ foot, Modified .....	Foot

**Culv, Precast Conc Box, \_\_ foot by \_\_ foot, Modified,** will be measured along the culvert centerline from apron edge to apron edge as detailed on the plans. The unit price for **Culv, Precast Conc Box, \_\_ foot by \_\_ foot, Modified** includes all labor, equipment and materials necessary to design, manufacture, load rate and install all precast elements including tie rod assemblies. Payment includes, PVC liner, cold-applied culvert joint sealer, treated plywood at top joints, closed-cell rubber extrusion type gaskets, 36-inch wide geotextile filter fabric, inserts and leveling shims.



CITY OF ANN ARBOR  
SPECIAL PROVISION  
FOR  
**DEWATERING SYSTEM FOR CONTAMINATED GROUNDWATER**

BBT:CED

1 of 3

4/2/24

**a. Description.** This work consists of all labor, equipment and materials required to lower the groundwater table to facilitate construction in the area of the excavation for the proposed culverts and pathway construction in the event the groundwater is found to be contaminated.

If the groundwater removed during the dewatering process is contaminated, it cannot be discharged directly to the ground surface or a surface water body. Dispose of groundwater removed in one of three ways:

1. To a sanitary sewer system, if permission is granted by the system owner (note that there is a permit fee and a per 100 cubic feet charge for the local sewer system);
2. To a surface water body under a National Pollutant Discharge Elimination System (NPDES) permit, or
3. Collected and hauled to an acceptable treatment facility.

The operation, monitoring, sampling and analysis of any treatment system used for discharge to a sanitary sewer or surface water body, or hauling to a treatment facility as needed is included in this work.

Groundwater throughout the project site may be contaminated, however, a sample was taken in 2022 just south/west of the railroad tracks near the proposed box culvert. This sample was tested which indicated it was not contaminated with dioxane, however, additional tests were not run.

Handle contaminated water in accordance with the Michigan Occupational Safety and Health Administration (MIOSHA) Standard for Hazardous Waste Operations and Emergency Response (HAZWOPER). Applicable workers must work under the direction of an on-site supervisor and a site-specific safety and health plan and must be trained and protected pursuant to the HAZWOPER Standard.

Provide to the Department, at the pre-construction meeting, documentation verifying the qualifications of Contractor personnel who will be performing the sampling and handling work. Provide a Safety and Health Plan as required by the MIOSHA standard.

Provide training for such sampling and handling for up to two Department designated employees as described in the MIOSHA standard, unless not required by the Engineer. If required, employees selected by the Engineer, must receive the 40 hour HAZWOPER training.

Provide personal protective equipment (as required by MIOSHA) for two Department designated employees with the exception of air purifying respirators. Department employees will provide their own fit tested air purifying respirators, if necessary.

Dewatering and disposal of groundwater that is not contaminated is considered included in other items of work.

**b. Well Points and Deep Wells.** Do not damage property or structures or interfere with the rights of the public, owners of private property, pedestrians, vehicular traffic and the work of other contractors should groundwater control be performed by deep well and/or well point pumping systems. Provide properly designed filters for any pumping methods used to ensure that adjacent soil will not be pumped with the water, thus creating voids underground around the face of the excavation or under existing structures. Submit filter design for review and approval by the Engineer before placement.

Perform the dewatering operation in a proper and predetermined sequence with the excavation operation such that the perimeter and face of the excavation is stable. Dewatering well diameter, pumping rate and well spacing must provide adequate drawdown of the water level. Locate wells to intercept groundwater that otherwise would enter the excavation and interfere with the work. Install observation wells at key locations for observation of groundwater levels during the excavation. The anticipated observation wells are, but not limited to, one per each 200 foot of trenching required for the dewatering system. Submit a plan for locations and monitoring frequency of the observation wells to the Engineer a minimum of 7 days in advance of placement of the dewatering system.

Discharge deep wells and/or well points in the area of contamination into header or collection pipes prior to entering the treatment system.

**c. Treatment System.** Filters or settling devices may be required before treatment to ensure that neither the treatment and sanitary sewer systems or surface waters are adversely affected by construction debris or increased sediment load.

Contaminated water must be treated to reduce contaminants to levels acceptable to the sanitary sewer system owner or NPDES permit. Base the treatment system on the contaminant to be treated, upon concentrations of contaminants found in the groundwater, the flow required to adequately dewater the trench as specified above, and an effluent concentration that meets the requirements of the sanitary sewer system owner or the NPDES permit. Submit the proposed system to the Engineer for approval prior to starting the work.

**d. Sanitary Sewer or Surface Water Discharge.** Monitor the volume of treated water discharged to the sanitary sewer system or as surface water discharge by using a totalizing turbine type flow meter. Place the flow meter inline on the treatment system effluent line. Design the flow meter for high flow applications and it must have a flow totalizing register that is adequately sealed to eliminate fogging and condensation. Submit the type of meter proposed to be used to the Engineer for review and approval prior to placement.

Supply a copy of the written authorization from the wastewater treatment plant authority to the Engineer prior to discharging any water to the sanitary sewer system.

Secure a NPDES permit from the Environment, Great Lakes, and Energy (EGLE) prior to any discharge to a surface water body.

Monitor and document daily the volume of flow being discharged to the sanitary sewer or the surface water by reading the register on the flow meter. Provide this information to the Engineer daily or as otherwise approved.

**e. Hazardous/Nonhazardous Material Handling.** Load and transport all hazardous and nonhazardous waste using properly trained personnel and placarded vehicles having a hazardous or liquid industrial waste manifest, as required. All manifests are to be signed by the Engineer or their representative. The terms hazardous and nonhazardous, as used in this document, are defined in 1994 PA 451, Parts 111 and 121, of the Natural Resources and Environmental Protection Act.

**f. Construction.** Determine the methods and materials required to accomplish this work, subject to approval by the Engineer before initiation or installation of the dewatering system.

Dewatering System for Contaminated Groundwater must be independent of other dewatering operations by a separate installation. Use the system for as short of time as necessary. Take all appropriate precautions to prevent exacerbation of contamination.

The Engineer may order corrective actions to the dewatering or treatment system at any time due to deficiencies in the system at no additional cost to the Department.

Artesian conditions exist in the area. Do not install wells deeper than elevation 760.00.

**g. Measurement and Payment.** The completed work, as described, will be measured and paid for at the contract unit price using the following pay items:

<b>Pay Item</b>	<b>Pay Unit</b>
Dewatering System for Contaminated Groundwater, Site .....	Dollar

**Dewatering System for Contaminated Groundwater, Site** includes all labor, equipment, materials, wells, piping, supplies, power, training, permit fees, filters, and fuel necessary for the installation, operation, maintenance, removal and the disposal of all surplus materials as described herein. This pay item includes the cost over and above the costs for Dewatering System, Excavation for treatment of all water pumped from below ground to facilitate underground construction if the water is found to be contaminated.

Disposal of contaminated soil or sediment excavated or displaced during the installation of this system, will be included in the pay item of **Non-hazardous Contaminated Material Handling and Disposal (LM)**.

CITY OF ANN ARBOR  
SPECIAL PROVISION  
FOR  
**SLOTTED DRAIN, GALVANIZED**

BBT:CED

1 of 2

3/7/24

**a. Description.** This work consists of furnishing and installing a 6 inch diameter galvanized slotted drain, including all necessary hardware at the location(s) shown on the plans. Complete this work in accordance with section 402 of the Standard Specifications for Construction, the details shown on the plans and this special provision.

**b. Materials.** Provide slotted drain fabricated from galvanized corrugated steel pipe. The materials must meet the applicable requirements specified in the following subsection and section of the Standard Specifications for Construction:

Corrugated Steel Pipe and Pipe Fittings.....	909.05
(6 inch dia., 16 gauge, galvanized, per AASHTO M 36)	
Concrete.....	601

Provide all associated items, such as steel grates, spacer plates, bolts, nuts, and washers as recommended by the manufacturer of the slotted drain and as approved by the Engineer and galvanized in accordance with AASHTO M 232.

The slotted opening must be 1¾ inches wide and a minimum 2-1/2 inches deep with a trapezoidal grate. The finish surface grating must be ADA compliant. The trapezoidal grate must have reinforcing spacer plates a minimum of 3/16 inch thick spaced 6 inches on center. The spacer plates must be slanted to direct flow toward the drainage structure.

All slotted drain is subject to visual inspection prior to acceptance and must conform to the requirements in the proposal.

**c. Construction.** Install the slotted drain to the line and grade shown on the plans or as directed by the Engineer. The slotted drain must be completely encased in concrete and poured monolithically as shown on the plans.

Prior to placing concrete and backfilling operations, the upgrade end of the slotted drain must be plugged with a metal cap. The slots (grate assembly) must be covered during encasement operations to prevent infiltration of concrete and other foreign material into the pipe.

Prior to placing the concrete, the slotted drain pipe must be secured in the proposed line and grade to prevent shifting or floating during the encasement stage of construction.

If positive flow or the final grade of the slotted drain is not maintained during the encasement stage of construction, the drain must be removed and replaced at the Contractor's expense.

**d. Measurement and Payment.** The completed work, as described, will be measured and paid for at the contract unit price using the following pay item:

<b>Pay Item</b>	<b>Pay Unit</b>
Slotted Drain, Galv, 6 inch .....	Foot

**Slotted Drain, Galv, 6 inch** will be measured in place by length in feet for the limits of the concrete encasement. Payment includes excavation, drainage structure taps, concrete encasement, and all necessary hardware, including metal caps, elbows, and the length of galvanized pipe required for the connection to drainage structures.

CITY OF ANN ARBOR

SPECIAL PROVISION  
FOR  
**CLEAN OUT**

BBT:CED

1 of 1

4/2/24

**a. Description.** This work consists of providing all labor, equipment, and materials for furnishing and installing clean out structures at the locations and elevations shown on the plans.

**b. Materials.** The materials must meet the applicable requirements specified in Section 909 of the Standard Specifications for Construction. The clean out diameter shall be 6 inches, length varies per plans. The clean out structure cover shall be a solid threaded plug.

**c. Construction.** Install the clean out structures at the locations and elevations shown on the plans or as directed by the Engineer in accordance with Section 403 of the Standard Specifications for Construction.

Prior to backfilling operations, the covers shall be placed on top of the clean out structures to prevent backfill material from entering the drainage system.

The clean out structures are to be installed simultaneously with the pipes they are connected to. If positive flow is not maintained during the backfilling stage of construction, the drainage system must be removed and replaced at the Contractor's expense.

**d. Measurement and Payment.** The completed work, as described, will be measured and paid for at the contract unit price using the following pay item:

<b>Pay Item</b>	<b>Pay Unit</b>
Clean Out .....	Each

**Clean Out** will be paid for each clean out installed as shown on the plans.

MICHIGAN  
DEPARTMENT OF TRANSPORTATION  
  
SPECIAL PROVISION  
FOR  
**REVISIONS TO PRECAST THREE-SIDED, ARCH, AND BOX CULVERTS**

STR:MJF

1 of 1

APPR:DMG:REL:05-23-23  
FHWA APPR:06-15-23

**Delete the first paragraph in subsection 406.02 shown on page 4-39 of the Standard Specifications for Construction and replace with the following:**

Provide natural coarse aggregate for Classes 6A, 26A, 6AA, and 17A in accordance with subsection 902.02. Provide aggregate with a gradation meeting Michigan Series 6AA, 17A, or 26A, the physical requirements of 6AA, and not exceeding the following nominal maximum size requirements:

- A. One-fifth the narrowest dimension between forms;
- B. One-third the depth of slabs; and
- C. Three-quarters the minimum clear spacing between individual reinforcing bars or wires.

**Delete the first sentence of the last paragraph in subsection 406.02 shown on page 4-40 of the Standard Specifications for Construction and replace with the following:**

Select a precast concrete culvert that meets the specific culvert shape (box, three-sided, or arch) detailed on the plans from the Approved Manufacturer list shown in the MDOT Materials Source Guide.

**Add the following after the last paragraph in subsection 406.02 shown on page 4-40 the Standard Specifications for Construction:**

The use of Type III cement requires 25-40 percent of the cement, by weight, to be replaced with a supplementary cementitious material (slag cement or fly ash).

The use of Class 26A coarse aggregate in the concrete mix design requires 25-40 percent of the cement, by weight, to be replaced with Grade 100 slag cement. The maximum loss by wash percent passing must be 2 percent.

CITY OF ANN ARBOR  
SPECIAL PROVISION  
FOR  
**CULVERT BEDDING**

BBT:CED

1 of 1

3/7/24

**a. Description.** This work consists of providing all labor, materials and equipment required to construct culvert bedding with open-graded aggregate 34R and coarse aggregate 6A wrapped with geotextile separator in accordance with section 406 of the Standard Specifications for Construction and as detailed on the plans, except as modified herein.

**b. Materials.** Provide open-graded aggregate 34R, coarse aggregate 6A, and geotextile separator materials meeting the requirements of sections 902 and 910 of the Standard Specifications for Construction, except provide coarse aggregate 6A with a minimum of 80 percent crushed natural aggregate.

**c. Construction.** Construct the culvert bedding in accordance with plan details and as directed by the Engineer.

**d. Measurement and Payment.** The completed work, as described, will be measured and paid for at the contract unit price using the following pay item:

<b>Pay Item</b>	<b>Pay Unit</b>
Culvert Bedding, Box Culvert.....	Cubic Yard

**Culvert Bedding, Box Culvert** will be measured in place by the cubic yard for the specified depth, width, and length as detailed on the plans and as directed by the Engineer.



CITY OF ANN ARBOR  
SPECIAL PROVISION  
FOR  
**STEEL SHEET PILING, TEMPORARY**

BBT:CED

1 of 3

3/7/24

**a. Description.** This work consists of furnishing, installing, maintaining, and cutting off the sheet piling and bracing, anchors, walers, related materials, and equipment required to maintain support of the sheeting and adjacent embankment and coordinated with the staged construction requirements at this site. Perform the work in accordance with section 704 of the Standard Specifications for Construction, the most current AREMA specifications with Cooper E-80 loading, Amtrak EP3014 (Section 02261A) – Requirements for temporary sheeting and shoring to support Amtrak Tracks, the plans and this special provision.

**b. Materials.** Provide materials in accordance with subsections 704.02 and 707.02 of the Standard Specifications for Construction.

**c. Construction.** Prepare working drawings, install and maintain the temporary steel sheet piling. Submit a written work plan for driving sheeting adjacent to the tracks in accordance with Amtrak's EP3014 and obtain approval prior to mobilizing equipment and driving sheeting.

Furnish and install sheet piling in accordance with Section 704 of the Standard Specifications, the contract plans, and this Special Provision. The sheet piling for this project shall be installed in stages that match the staged construction shown on the plan.

When no longer needed, remove or cut off the sheet piling during the staged construction as shown on the plans or as approved by the Engineer. Coordinate installation and cutting of the temporary sheet piling in stages and ensure it is tightly sealed.

The temporary steel sheet piling design shown in the plans and described in this special provision has already been approved by Amtrak. Alternate temporary retaining wall design options may be considered for this project provided that alternate designs are prepared and submitted in accordance with the information provided below. All alternate temporary retaining wall design options must conform to AREMA & Amtrak specifications and/or guidelines. Alternate temporary retaining wall designs must be approved by Amtrak prior to installing the sheet piling. Any extra costs or delays due to this review process are the responsibility of the Contractor.

Alternate steel sheeting options must be designed as cantilever or braced steel sheet piling walls interacting with the soil using the following software: SPW 911 by PileBuck International Inc.; SupportIT by GTSOFT Ltd.; CWALSHT by US Army Corps of Engineers or CivilTech Software Shoring Suite. The use of other software will be reviewed by the Department and requires approval by the Engineer prior to use. Hand calculations and/or spreadsheet calculations will not be accepted for steel sheet piling design unless special conditions are present, which will require approval by the Engineer prior to use. Hand calculations and/or spreadsheet calculations (with example hand calculations) for design of anchors, walers, bracing sections, weld details and connections is acceptable.

Design the steel sheet piling, ground anchors, deadman, bracing sections, and adjacent excavations to support moving train loads. Assume a live load surcharge in accordance with AREMA & Amtrak specifications. The calculated and measured maximum total deflection of the steel sheet piling must not exceed 1 inch. Include supporting calculations for the steel sheet piling including: sheeting, anchors, waler, bracing sections, welded or bolted connection details, sheeting tip elevations, calculated deflection of sheeting sections, all connections and embedment depth. The design must consider and provide supporting calculations for all stages of construction.

If ground anchors are used, a load testing program must be submitted and reviewed by the Department with the design submittal. The Contractor’s designer must reference *FHWA Publication No. FHWA-IF-99-015 (Geotechnical Engineering Circular No. 4, Ground Anchors and Anchored System)* in the design and load testing program. All ground anchors, regardless of anchor type, must be load tested to meet a total unfactored tension force of 54 kips. All ground anchors and walers must be prestressed and locked off. Ground anchors and walers that cannot be prestressed to the required load and locked off cannot be used.

In the case of alterations to the design shown on the plans, ensure that the design is prepared by the Contractor’s designer; and the designer is a Professional Engineer, licensed in the State of Michigan. Submit the design and supporting calculations to the Engineer for review and approval by Amtrak not less than 45 calendar days prior to beginning of work. Obtain the Engineer’s approval of the steel sheet piling design prior to beginning installation. The Department will require 10 calendar days for each review cycle and revisions may be required following each review. No extension of time or additional compensation will be granted due to delays in preparing the final working drawings, calculations and material specifications or securing acceptance from the Department. An exception may be granted for an extension of time only in the case that the Department’s review of a submittal exceeded 10 calendar days and if it can be shown that such a delay impacts the final project completion date.

Artesian conditions exist in the area. Do not install sheeting deeper than elevation 760.00.

**e. Measurement and Payment.** The completed work, as described, will be measured and paid for at the contract unit price using the following pay item:

<b>Pay Item</b>	<b>Pay Unit</b>
Steel Sheet Piling, Temp, Left in Place, Special .....	Square Foot
Steel Sheet Piling, Temp, Special.....	Square Foot

**Steel Sheet Piling, Temp, Left in Place, Special and Steel Sheet Piling, Temp, Special** quantities will be computed based on the area of required earth retention. The vertical dimension for computing areas will be the difference in ground elevation at the sheeting line or the planned foundation excavation limit at the sheeting line, whichever is less. Unless shown on the plans, the lateral limits will be determined by the design. When earth is retained on both sides of the same steel sheet piling during different construction stages, the quantity will be computed from the stage requiring the largest area of earth retention and not the sum of the area of required earth retention for each stage.

All horizontal measurements will be made along the sheet piling alignment without allowance for the structural shapes of the separate sections.

Payment for lateral bracing (anchors, walers and associated components), their removal, and their reinstallation where required, will not be paid for separately, but is included in payment for **Steel Sheet Piling, Temp, Left in Place, Special** and **Steel Sheet Piling, Temp, Special**.

CITY OF ANN ARBOR  
SPECIAL PROVISION  
FOR  
**DECORATIVE PANEL, FURNISH AND INSTALL**

BBT:CED

1 of 2

3/19/24

**a. Description.** This work consists of furnishing decorative panels including all anchors, fasteners, equipment and labor to install decorative panels inside the box culvert. This work also includes coordinating with an artist for specific hole pattern and etching on the individual panels.

**b. Materials.**

1. Structural Steel Angle Connections. Furnish materials per subsections 906.04 and 906.08 of the Standard Specifications for Construction. Use Gr. 36 steel, galvanized. Coat the panels in accordance with Section 707 of the Standard Specifications for Construction. Color to be determined by Owner.
2. Decorative Panels. Furnish materials per subsections 906.04 and 906.08 of the Standard Specifications for Construction. Use galvanized 11 gauge steel. Coat the panels in accordance with Section 707 of the Standard Specifications for Construction. Color to be determined by Owner. Provide flat panels with finished end pattern and perforations as directed by the Owner (pattern and hole sizing to be determined by the Owner). Example images of intent for these panels are included in this Special Provision.
3. Adhesive Anchors. Use adhesive anchors from MDOT's Qualified Products List.
4. Fasteners. Furnish materials per subsection 906.07 of the Standard Specifications for Construction.

**c. Submittals.** Prepare complete working drawings of connection supports and fasteners to support the panels. Coordinate with the Owner regarding hole pattern, sizing, and finish. Do not begin working drawings until the panels are supplied to verify connection details.

Coordinate adhesive anchor holes within the box culvert with the box culvert manufacturer to avoid conflict with steel reinforcement. Confirm rebar locations in culvert prior to fabricating connection supports. Use a pachometer to mark reinforcement in culvert if other identifying methods are not used.

Show proposed curb, lighting conduit, and fixtures on the working drawings to ensure no conflicts. Ensure there is adequate room between the culvert wall and the panels for the proposed lighting fixtures and conduit. Ensure connection supports do not conflict with proposed lighting conduit or fixtures.

Connection supports must be concealed behind the decorative panel with only visibility being through designed perforations in the panels.

**d. Construction.** Take field measurements within the completed box culvert installed in the field to verify location of connection supports and layout of decorative panels.

Locate rebar within the box culvert concrete using a pachometer prior to drilling holes for

adhesive anchors connection supports. Do not cut rebar during drilling.

Coordinate connection supports and panel installation with the proposed lighting conduit and fixtures.

Adjust the connections as necessary to provide a level and plumb decorative panel. Readjust for any variation out of level greater than 1/4-inch between adjoining panels. Readjust for any variation out of plumb greater than 1/8-inch between adjoining panels.

**e. Measurement and Payment.** The completed work, as described, will be measured and paid for at the contract unit price using the following pay item:

<b>Pay Item</b>	<b>Pay Unit</b>
Decorative Panel, Install.....	Lump Sum
Decorative Panel, Furn.....	Dollar

**Decorative Panel, Install** includes all labor, materials and equipment to install the decorative panels as shown on the plans, including the shop drawings and layout of the panels and installation components. **Decorative Panel, Furn** will includes the panels, aesthetic treatment applied to them, and coordinating with the Owner’s designer/artist. Art work design will be provided by the owner to the Contractor’s fabricator for production.



*Example images for intent of the product to be provided*

CITY OF ANN ARBOR

SPECIAL PROVISION  
FOR  
**TIMBER BRIDGE**

BBT:CED

1 of 2

3/20/2024

**a. Description.** This work consists of furnishing materials for, and constructing a timber bridge in accordance with Sections 709, 908, and 912 of the Standard Specifications for Construction, the project plans and this special provision.

**b. Materials.**

1. Wood. Provide wood members that are Coast Region Douglas Fir or Southern Yellow Pine species. Provide commercial grade lumber for beams, joists, blocking and deck panels that are similar to 2400f-1.6E(MSR). For all other members, provide lumber similar to 1200f-1.2E(MSR). All lumber sizes are nominal. Provide lumber that is conditioned and pressure-treated in accordance with the requirements of AWPA C2 with the preservative chemical used meeting applicable EPA requirements. The use of waterborne chemicals will not be allowed.

Handrails and posts must be conditioned and pressure-treated with a clean preservative such as pentachlorophenol.

Field cutting and drilling of wood members will not be allowed unless all cuts and field-drilled holes are brush treated with a 5% pentachlorophenol solution or other approved field-treatment. Creosote solutions will not be approved for field-treatment.

All wood members must have a smooth surface finish.

Manufacturer must submit a certificate attesting to compliance with preservative specifications.

2. Hardware. Provide hardware that is hot-dip galvanized and conforms to section 908.

Provide bolts, nuts, and washers used for assembly that conform to the requirements of ASTM A 325 and are hot-dip galvanized in accordance with ASTM A 153 or are stainless steel.

Provide steel plate brackets in accordance with ASTM A36 steel with hot-dip galvanized coating conforming to the requirements of ASTM A 153.

Provide nails that are galvanized 60d (6") spiral shank.

Provide all hardware and accessories required to properly and completely execute the carpentry for this project, including, but not limited to: screws, bolts, nuts, washers, straps, and similar items, whether specifically mentioned herein or not.

**c. Construction.** Construction must conform to sections 709 and 912 of the Standard Specifications for Construction except as described herein.

Furnish all lumber and install making sure all carpentry work is plumb, level and true to line and grade, and meets standard industry practices. All railings and caps must be sanded smooth and have rounded edges. Ensure all exposed edges are free from splinters and that sharp edges are sanded smooth. Pre drill toe nailed and lumber ends to prevent splitting. Nails must not protrude through the backside of any member.

Timber bridge is to be built at the location shown on the plans.

The approaches and bridge surface must meet all American with Disabilities Act criteria.

The low chord of the bridge must not be below that shown on the plans.

Prepare shop drawings for review and approval by the Engineer prior to starting work. The Engineer will require up to 2 weeks for review of each shop drawing submission.

**d. Measurement and Payment.** The completed work as described will be measured as a lump sum and paid for at the contract unit price using the following pay items:

<b>Contract Item (Pay Item)</b>	<b>Pay Unit</b>
Timber Bridge.....	Lump Sum

**Timber Bridge** includes all labor, equipment and materials for developing shop drawings, furnishing and installing the timber bridge, including all wood members, posts, railing, hardware and fasteners, required to perform the completed work herein as described and shown on the contract documents. Miscellaneous metals and hardware will not be paid for separately, but will be included in the payment for **Timber Bridge**.

Substructure concrete, reinforcement steel, excavation and backfill will be paid separately.

CITY OF ANN ARBOR  
SPECIAL PROVISION  
FOR  
**MODULAR BLOCK WALL**

BBT:CED

1 of 3

3/21/2024

**a. Description.** This work consists of the design, manufacture, furnishing and installation of a gravity modular block wall as shown on the plans. This work includes preparing a leveling pad or base; erecting the wall; and placing backfill for the wall. Complete this work in accordance with the standard specifications, details shown on the plans, the wall system manufacturer's recommended installation procedures and this special provision.

Furnish modular block units by the manufacturer listed below and the specified finish. Alternate suppliers and finish may be considered as an approved equal:

Recon Wall Systems  
[www.reconwalls.com](http://www.reconwalls.com)  
952-922-0027  
24 to 84 inch Series  
Northshore Granite

Design the modular block walls in accordance with the *AASHTO LRFD Bridge Design Specifications*.

**b. Submittals.** Submit shop drawings and calculations prepared and stamped by a Professional Engineer licensed in the State of Michigan to the Engineer. Allow up to 3 weeks for review of the shop drawings. No work can begin on the gravity modular block wall prior to approval of the shop drawings. Shop drawings must include:

1. The modular wall layout, height and typical wall sections. With positive connection details between modular block units and caps.
2. Construction details; including requirements for block retention, foundation soils, underdrains, and backfill aggregates.

Furnish the manufacturer's recommended installation procedure and a sample of color and texture to the Engineer for approval at the preconstruction meeting.

**c. Materials.** Furnish materials meeting the following sections of the standard specifications:

Drainage Aggregate - Open-Graded Aggregate 34R .....	902
Leveling Pad Aggregate - Dense-Graded Aggregate 21AA .....	902
Underdrain .....	909
Non-Woven Geotextile Separator .....	910
Backfill, Structure, CIP .....	206
Limits of Excavation, FDN .....	206

Flowable fill will be as approved by the Engineer.



Use modular wall and cap blocks in accordance with the following:

1. Ensure concrete meets Grade 4000 requirements in accordance with section 1004 of the Standard Specifications for Construction and has 5.5 to 8.5 percent entrained air content.
2. Provide manufacturer's test data certification, in accordance with the *Materials Quality Assurance Procedures Manual*, documenting that the concrete materials meet Grade 4000 requirements.
3. Ensure the standard block units conform to the nominal dimensions as shown on the plans unless otherwise approved by the Engineer.
4. Provide modular block cap with a smooth finish.
5. Provide water borne color surface coating in accordance with manufacturer's recommendations. Obtain color from Owner prior to ordering.

Protect blocks from damage, chipping and soiling during delivery, storage and installation. Store block units off the ground on pallets, wood platforms or other approved method. Do not use blocks with chips, cracks, voids, discoloration or other visible defects.

**d. Construction.** Erect the wall in accordance with the details shown on the plans, manufacturer's recommendations and the following:

1. Excavate to the line and grade shown on the plans, or as directed by the Engineer, for construction of the leveling pad. Prior to placing the leveling pad, the Engineer will determine the suitability of the in situ soil. Excavate unsuitable soils to the limits determined by the Engineer and backfill in accordance with section 206 of the Standard Specifications for Construction. Brace excavation as required to protect the existing gas main.
2. Construct leveling pad to the dimensions required by the modular block manufacturer. Compact leveling pad to at least 95 percent of the maximum unit weight to provide a level, firm surface on which to place the first course of blocks. If a flowable fill leveling pad is required, construct to the dimensions shown on plans. Ensure flowable fill is completely cured prior to placing the first course of blocks.
3. Place the first course of blocks in full contact with the prepared leveling pad and in accordance with the manufacturer's instructions. Construct each course to grade for the entire length of the wall. If any course deviates from the grade more than 1 inch per 10 feet, remove the entire course and reinstall. All costs associated with this removal and reinstallation will be at no cost to the contract.
4. Place the foundation underdrain as shown on the plans and in accordance with the standard specifications.
5. Place non-woven geotextile separator against the backside of wall and backfill behind the wall with drainage aggregate. In addition, place non-woven geotextile separator between drainage aggregate and structure backfill. Remove damaged geotextile caused by the Contractor's operation and replace at no cost to the contract. Place the drainage aggregate a minimum of 1 foot wide behind the back of wall and extending vertically to an elevation 4

inches below the top of wall. Fill voids between and within block units with drainage aggregate in accordance with manufacturer’s recommendations.

**e. Measurement and Payment.** The completed work, as described, will be measured and paid for at the contract unit price using the following pay item:

<b>Pay Item</b>	<b>Pay Unit</b>
Modular Block Wall.....	Square Foot
Modular Block Wall, Cap.....	Foot

**Modular Block Wall** will be measured in place, in square feet of wall face, from the top of the leveling pad to the bottom of the wall cap.

**Modular Block Wall, Cap** will be measured in place, in linear feet of wall cap placed, measured along the centerline of the wall cap.

**Modular Block Wall** and **Modular Block Wall, Cap** includes installation and furnishing all labor, equipment and materials necessary to complete the work as described including all excavation, bracing for excavation, backfill, and underdrain.

Excavation of unsuitable soils and backfill with suitable soils of this excavation will be paid for separately.

CITY OF ANN ARBOR  
SPECIAL PROVISION  
FOR  
**SHARED USE PATH, AGGREGATE, \_ INCH, MODIFIED**

BBT:CED

1 of 1

3/12/24

**a. Description.** Perform work in accordance with sections 302 and 806, Aggregate Base Courses and Shared use Paths, of the Standard Specifications for Construction except as herein provided.

**b. Materials.** Furnish aggregate materials meeting the requirements as specified in section 902 of the Specifications for Construction, Table 902-1 and 902-2 for 21AA dense-graded aggregate. Do not use MDOT 21AA Limestone.

**c. Construction.** Construct the Aggregate Base Course in accordance with sections 302.03 and 806.03 of the Standard Specifications for Construction.

**d. Measurement and Payment.** The completed work, as described, will be measured and paid for at the contract price using the following pay item:

<b>Pay Item</b>	<b>Pay Unit</b>
Shared use Path, Aggregate, __ inch, Modified.....	Square Yard
Shared use Path, Aggregate, Tunnel.....	Cubic Yard

**Shared use Path, Aggregate, \_\_ inch, Modified** and **Shared use Path, Aggregate, Tunnel** will be measured in place based upon the average length and width measurements as determined in the field by the Engineer. The contract unit price includes full for all labor, materials, and equipment necessary to construct the aggregate base in accordance with the plan details.

CITY OF ANN ARBOR  
SPECIAL PROVISION  
FOR  
**SHARED USE PATH, CONC, \_ INCH**

BBT:CED

1 of 2

3/12/24

**a. Description.** Perform work in accordance with sections 602 and 806, Concrete Pavement Construction and Shared use Paths, of the Standard Specifications for Construction except as herein provided.

**b. Materials.** Furnish concrete pavement materials in accordance with sections 602.02 and 806.02 of the Standard Specifications for Construction. Provide Concrete Grade 3500 for all Shared use Paths.

Furnish epoxy coated reinforcement steel for the integral curb detail in accordance with Section 706 and Section 905 of the Standard Specifications for Construction.

**c. Construction.** Construct the Shared use Path in accordance with sections 602.03 and 806.03 of the Standard Specifications for Construction and as detailed in the drawings.

Place concrete to a depth indicated on the plans.

Space transverse plane-of-weakness joints at 10-foot intervals unless otherwise shown on the plans. Space full-depth transverse expansion joints at 200-foot intervals but not within the decorative tunnel section at the proposed tunnel. Provide joints as shown on the plans within the tunnel section.

Tooled transverse and longitudinal joints are not permitted except within the decorative tunnel section. Saw cut transverse and longitudinal joints outside of the decorative tunnel section.

Construct pathway joints and finish the surface within the decorative tunnel section in accordance with the plan details. Provide means for finishing concrete as shown or stage pours such that access is maintained to finish as shown.

Coordinate joint layout with decorative panel locations. Provide joints that line up with the joints in the decorative panels.

Coordinate joint layout and finish with slotted drain locations.

Form the integral curb after the pathway concrete has cured. Provide a thin bond breaker between the culvert wall and the back of curb.

**d. Measurement and Payment.** The completed work, as described, will be measured and paid for at the contract price using the following pay item:

<b>Pay Item</b>	<b>Pay Unit</b>
Shared use Path, Concrete, _ inch.....	Square Yard
Shared use Path, Concrete, _ inch, Decorative.....	Square Yard

**Shared use Path, Conc, \_\_ inch** and **Shared use Path, Conc, \_\_ inch, Decorative** will be measured in place by area in square yards based upon the average length and width measurements as determined in the field by the Engineer and will be paid based on the required thickness in inches. The contract unit price includes payment in full for all labor, materials, and equipment necessary to construct the concrete pavement path in accordance with the plan details including the decorative finish, integral curb, and epoxy coated reinforcement within the decorative tunnel section.

CITY OF ANN ARBOR  
SPECIAL PROVISION  
FOR  
**SHARED USE PATH, GRADING, MODIFIED**

BBT:CED

1 of 2

3/12/24

**a. Description.** Perform work in accordance with sections 806 Shared use Paths, of the Standard Specifications for Construction except as herein provided.

This work consists of all labor, materials, and equipment necessary to perform excavation, stump removal, ditching, swales, wall backfill, embankment and grading required for trail construction as well as proof rolling to verify the uniformity of support and to identify unstable areas which might require repairing, undercutting and replacement. Complete this work at locations as shown on the plans and in accordance with typical cross sections or as directed by the Engineer.

**b. Materials.** Furnish materials that meet the requirements specified in the Standard Specifications for Construction.

**c. Construction.** Complete work in accordance with section 806 of the Standard Specifications for Construction and as modified herein.

Utilize this Contract Item for mainline pathway as well as sidewalk ramps and driveways.

Clear and remove all brush, debris, stumps, and all trees less than six (6) inches DBH as shown on the plans or as directed by the Engineer. Prune trees as necessary to allow construction equipment to traverse the alignment without damaging tree limbs.

Cut any tree roots that interfere with pathway construction and apply sealer to cutoff root ends greater than 3-inches in diameter. Sawcut tree roots 2-feet outside the proposed edge of pavement as shown in the plans. Root cutting shall only be performed with Engineer approval following a walkthrough with the Engineer.

Remove or grind all stumps within the grading limits. Remove stumps within a 1:1 influence of any pavement. Grind stumps within the grading limits, but outside the 1:1 influence of pavement down to 3-inches below grade.

Strip and stockpile topsoil for future use.

**d. Measurement and Payment.** The completed work, as described, will be measured and paid for at the contract price using the following pay item:

<b>Pay Item</b>	<b>Pay Unit</b>
Shared use Path, Grading, Modified.....	Foot

The Engineer will measure **Shared use Path, Grading, Modified** in place, along the centerline of the path, and within the limits shown on the plans. The unit price for **Shared use Path, Grading, Modified** includes the cost of the following:

1. Required brushing and tree trimming and removing and disposing of excess material, including removal of stumps within the grading limits;
2. Miscellaneous concrete removal including concretes pads, concrete footings and concrete bumper blocks.
3. Stripping and salvaging of topsoil layer where present;
4. Excavation including transporting excavated material to fill sections, stockpiling, haul-off and disposal of excess material;
5. Grading for ditching, swales, and drainage features;
6. Providing embankment through project excavated material or imported fill materials;
7. Compacting the grade per the requirements and as directed by the Engineer;
8. Grading for sidewalk and curb ramps;
9. Fine grading of constructed grades or existing ground that requires no further shaping than the removal of the root mat or vegetative cover; and
10. Earthwork associated with Modular Block Retaining Wall construction, outside of the finished grade shown in the drawings, is included in Modular Block Wall items of work.

Excavation in areas requiring retaining walls, culverts, or storm sewers as shown on the plans or as directed by the Engineer will be paid for in other items.

Screening and placing salvaged topsoil will be paid for separately as Turf Establishment, Performance.

All other miscellaneous excavation and embankment within rights-of-way or designated easement areas will be included in the pay item **Shared Use Path, Grading, Modified** and will not be paid for separately.

CITY OF ANN ARBOR  
SPECIAL PROVISION  
FOR  
**FENCE, RUSTIC SPLIT RAIL (2 RAIL)**

BBT:CED

1 of 2

3/8/24

**a. Description.** This work consists of furnishing and installing rustic split rail fence at the locations shown on the plans, in accordance with section 808 of the Standard Specifications for Construction and as directed by the Engineer.

**b. Materials.** Posts and rails must be Western Red Cedar (*Thuja plicata*), Northeastern White Cedar (*Thuja occidentalis*), Black Locust (*Robinia pseudoacacia*) or approved equal and commercially available. Both the posts and the rails may vary considerably in width and thickness with specified dimensions being average and approximate only.

All longitudinal splitting must be by axe, froe or wedge. Cut, torn or rough grain will not be classified as defects. All knots must not exceed 1/2 inch and must be firmly in place.

Spiral grain must not exceed 1/4 twist in length. Kinks, bends or sweeps must not exceed the narrowest dimension from a straight line from center to center.

Outer bark, sap rot, char and other unsightly discolorations will not be permitted, but limited heart rot in streaks and pockets as well as rusty colorations due to normal weathering and seasoning will be permitted. Scars, wounds, splits or seasoning checks must not exceed 1/4 depth of area affected.

Gravel material placed below posts will be dense-graded aggregate Class 22A. Backfill material for the posts will be sound earth or as approved by the Engineer.

1. Post and Rail Specifications. Posts must measure 4 inches by 5 inches by 6 feet in length. The girth when measured between the two mortise openings must be at least 18 inches.

The distance from the top of the post to the first mortise opening must be 6 inches and the distance, center to center, between the mortise openings must be 14 to 16 inches. The mortise opening of end and corner posts must be 1¾ inches wide and approximately 4½ inches in length. End and corner posts will be required at the appropriate locations.

Rails will measure 2 inches by 4 inches by 8 to 10 feet in length with a minimum girth of 12 inches. Tenon area must be 3 inches in length by 1½ inches in thickness and 3½ inches in width ±1/2 inch. The bottom of the lower rail must be no more than 1 foot above the existing ground.

**c. Construction.** Place posts in 12 inch diameter holes 30 inches deep. Prior to installing post, place 6 inches of 22A aggregate in the bottom of the post hole and compacted in place. Plumb and level posts, install rails and backfill with approved soil and compact in place as directed by the Engineer.



**d. Measurement and Payment.** The completed work, as described, will be measured and paid for at the contract unit price using the following pay item:

<b>Pay Item</b>	<b>Pay Unit</b>
Fence, Rustic Split Rail .....	Foot

**Fence, Rustic Split Rail** includes all labor, equipment and materials necessary to furnish and install the item as described.

CITY OF ANN ARBOR  
SPECIAL PROVISION  
FOR  
**FENCE, CHAIN LINK, SPECIAL**

BBT:CED

1 of 1

3/7/24

**a. Description.** This work consists of furnishing and erecting a polyvinyl chloride (PVC) coated steel chain link fence and gate at the locations shown on the plans.

**b. Materials.** Provide galvanized fencing materials that are coated in PVC in accordance with subsection 907.04 of the Standard Specifications for Construction and Amtrak Standard Structures Plan SP3003 with the following exceptions and additions:

1. Fabric. The core must be at least 0.148 inches in diameter. PVC coated steel chain link fence fabric must meet ASTM F 668 Class 2b. Class 2b designation consists of PVC coated fused and adhered to zinc coated steel wire.
2. Fence posts. The thickness of the PVC coating must be 10-14 mils applied by fusion bonding.
3. The color of the PVC coating must be black, and in accordance with ASTM F 934.

Provide a General Certification that the materials provided meet the requirements stated above. The Department will conduct acceptance testing per subsection 907.02 of the Standard Specifications for Construction.

**c. Construction.** Construct chain link fence in accordance with subsection 808.03 of the Standard Specifications for Construction.

Submit 6 complete sets of manufacturer's shop drawings for approval to the Engineer a minimum of fourteen (14) calendar days prior to fabrication of the materials. Do not fabricate any materials prior to receiving approval from the Engineer.

**d. Measurement and Payment.** The completed work, as described, will be measured and paid for at the contract unit price using the following pay item:

Pay Item	Pay Unit
Fence, Chain Link, __ inch, Special.....	Foot
Fence Gate, 14 foot, for 72 inch Chain Link Fence, Special.....	Each

**Fence, Chain Link, \_\_ inch, Special and Fence Gate, 14 foot, for 72 inch Chain Link Fence, Special** will be measured in place and includes furnishing and installing posts, braces, fabric and hardware. Construction and material for the concrete fence post footings will not be paid for separately, but will be included in **Fence, Chain Link, \_\_ inch, Special and Fence Gate, 14 foot, for 72 inch Chain Link Fence, Special**.

CITY OF ANN ARBOR  
SPECIAL PROVISION  
FOR  
**FENCE, PROTECTIVE, SPECIAL**

BBT:CED

1 of 1

3/8/24

**a. Description.** This work consists of furnishing and installing protective fencing horizontally in the areas shown on the plans.

**b. Materials.** Provide protective fencing material in accordance with subsection 907.06 of the Standard Specifications for Construction with the following exceptions and additions:

1. Provide protective fence material in new condition.
2. Wood posts are not required for this type of installation.

**c. Construction.** Install protective fence horizontally in the areas shown on the plans. The fence is intended to act as a protective barrier to warn future excavations from extending below it. Install protective fence such that the edges of each roll of fence are touching. Use soil anchors to hold the fencing in place while backfill and embankment are placed.

**d. Measurement and Payment.** The completed work, as described, will be measured and paid for at the contract unit price using the following pay item:

<b>Pay Item</b>	<b>Pay Unit</b>
Fence, Protective, Special .....	Square Foot

**Fence, Protective, Special** will be measured in place and includes furnishing and installing the protective fence material and soil anchors. Backfill and embankment will be paid for separately.

CITY OF ANN ARBOR  
SPECIAL PROVISION  
FOR  
**ORNAMENTAL ALUMINUM FENCE, \_\_ INCH**

BBT:CED

1 of 2

3/8/24

**a. Description.** This work consists of furnishing and installing an ornamental aluminum fence at the locations specified in the contract plans.

**b. Materials.** Provide style, UAB-200 Flat-Top Flush, as manufactured by Ultra Aluminum Mfg., Inc. or Echelon Majestic 3-Rail, as manufactured by Ameristar or equivalent. Provide fence components of industrial weight extruded 6005-T5-alloy aluminum and the meets the following:

<u>Components</u>	<u>Dimension/Feature</u>
Pickets	1" sq. x 0.062" thick
Rails: Top Walls	1-5/8" x 0.070" thick
Side Walls	1-5/8" x 0.100" thick Three (3) per section
Standard Posts (End & Line Posts)	2-1/2" sq x 0.100" thick
Spacing Between Pickets	4"
Post Spacing	See Plan Details
Color	Gloss Black
Finish	Powder Coated
Depth of Concrete Footings for Posts	3' w/ 3" bottom clearance

For posts mounted to concrete walls, see base plate details on the plans. Use anchor bolt material in accordance with subsection 908.14.D of the Standard Specifications for Construction. Steel base plates must conform to subsection 906.04.A of the Standard Specifications for Construction.

Assemble fence sections with stainless steel, corrosion resistant screws, with the screw heads painted to match the finish of the fence.

Provide concrete fence post foundations that conform to Section 808 of the Standard Specifications for Construction.

**c. Construction.** Construct the Ornamental Aluminum Fence in conformance with subsection 808.03 of the Standard Specifications for Construction and as directed by the manufacturer.

Place fence posts, both end and line, in concrete footings to the dimensions listed above.

Place the grounding cable in a non-metallic conduit from end post connection to the ground rod connection. Secure the conduit to the structure using expansion bolts or adhesive anchored bolts with galvanized metal strips, as approved by the Engineer.

Protect components and assemblies from damage during shipping and handling in accordance with the manufacturer’s recommendations. Repair any painted surface that has been damaged during shipping or assembly per the manufacturer’s recommendations to the satisfaction of the Engineer. If satisfactory repairs cannot be made, replace damaged components. All costs associated with repairing and replacing damaged components will be covered by the Contractor.

**d. Submittals.** Electronically submit working drawings to the Engineer for review and approval at least 20 calendar days prior to fabrication. Working drawings must include details of fabrication, installation including, but not limited to: plan views, elevation views, section views, component details, hardware and fittings details, galvanization and coating details. Submit representative samples of coated fence components to the Engineer for review and approval not less than 30 calendar days prior to working drawing submittal. In addition, electronically submit the following information to the Engineer for approval not less than 30 calendar days prior to working drawing submittal:

1. Name, location and contact information where powder coating of fence will be performed.
2. Quality Control (QC) programs established and followed by the firm performing powder coating operations.
3. Powder coating plan, including identification of the powder coating materials used (and manufacturer), specific cleaning, surface preparation, pre-heating, powder coating application, curing, shop and field coating repair, handling and storage processes.
4. Product data and material safety data sheets (MSDS) for all powder coating and coating repair materials.

**e. Measurement and Payment.** The completed work as described, will be measured and paid for at the contract unit price using the following pay item:

<b>Contract Item (Pay Item)</b>	<b>Pay Unit</b>
Ornamental Aluminum Fence, __ inch.....	Foot

**Ornamental Aluminum Fence, \_\_ inch** will be measured and paid for at the contract unit price for each foot of fence installed. The price includes all labor, materials and other appurtenances for furnishing and installing the **Ornamental Aluminum Fence, \_\_inch** complete and in place as described herein and includes furnishing and installing posts, rails, pickets, hardware, and adhesive anchors. Construction and material for the concrete fence post footings will not be paid for separately, but will be included in **Ornamental Aluminum Fence, \_\_ inch**.

MICHIGAN  
DEPARTMENT OF TRANSPORTATION  
  
SPECIAL PROVISION  
FOR  
**TEMPORARY PEDESTRIAN TYPE II BARRICADE**

COS:CRB

1 of 2

APPR:CAL:CT:03-01-21  
APPR:FHWA:03-08-21

**a. Description.** This work consists of delivering, installing, maintaining, relocating, and removing a temporary pedestrian Type II barricade section as identified in the proposal or on the plans. Use temporary pedestrian Type II barricades to close non-motorized facilities including sidewalks, bicycle paths, pedestrian paths, and shared use paths that are not part of the roadway. One pedestrian Type II barricade is defined as a barricade section at least 43 inches wide, including all supports, ballast, and hardware.

**b. Materials.** Provide a temporary pedestrian Type II barricade that meets the requirements of *National Cooperative Highway Research Program Report 350 (NCHRP 350)* or *Manual for Assessing Safety Hardware (MASH)*, in addition to meeting the following requirements:

1. Provide barricade sections at least 43 inches wide, designed to interconnect to ensure a continuous accessible tactile barrier. Ensure the connection includes provisions to accommodate non-linear alignment as well as variations in elevation at the installation area.

2. Ensure the top surface of the barricade is designed to function as a hand-trailing edge and has a height between 32 and 38 inches. Ensure the lower edge of the barricade is no more than 2 inches above the surface of the non-motorized facility. Ensure the top edge of the bottom rail of the barricade is a minimum of 8 inches above the surface of the non-motorized facility. The barricade may have a solid continuous face. Finally, all features on the front face of the barricade (the face in contact with pedestrians) must share a common vertical plane.

3. Equip both sides of the barricade with bands of alternating 6-inch wide orange and white vertical stripes of reflective sheeting. Two bands of sheeting 6 inches tall and a minimum of 36 inches long containing at least two orange and two white stripes each are required. One band placed near the top and one near the bottom if the barricade section has a solid face. If the barricade consists of two rails, affix one band of sheeting to each rail. Ensure the stripes of reflective sheeting are aligned vertically. Ensure this sheeting meets or exceeds the requirements of *ASTM D4956, Type IV* sheeting.

**c. Construction.** Construct the temporary pedestrian Type II barricade in accordance with the manufacturer's recommendations, MMUTCD, the plans, and the following requirements:

1. Install the barricade as shown on the plans and as directed by the Engineer. Interconnect all barricade sections using hinge components, if necessary, to ensure a continuous detectable edge for the entire installation. Ensure the barricade is ballasted in accordance with the manufacturer's recommendations to ensure stability during wind events and contact with pedestrians.

2. When the barricade is installed near motor vehicle traffic, ensure reflective sheeting is visible to motorists.

3. When temporary pedestrian Type II barricades are used to close a non-motorized facility, ensure a sufficient number of barricade sections are used to block the entire width of the facility. The barricade may extend outside the edge of the non-motorized facility but must not be less than the full width of the facility.

4. If sections of multiple-colored barriers are used (i.e. safety orange and white) install the sections such that the colors alternate to increase conspicuity.

5. Ensure temporary pedestrian Type II barricades are not used to close a motor vehicle facility. Ensure these barricades are not used to guide pedestrian traffic on a motor vehicle facility in the presence of active traffic. This prohibition includes bicycle/shared use lanes or shoulders in the presence of active traffic.

**d. Measurement and Payment.** The completed work, as described, will be measured and paid for at the contract unit price using the following pay item:

<b>Pay Item</b>	<b>Pay Unit</b>
Pedestrian Type II Barricade, Temp .....	Each

**Pedestrian Type II Barricade, Temp**, includes delivering, installing, maintaining, relocating, and removing one barricade section that is at least 43 inches wide. Additional payment will not be made if wider sections are provided. Payment will be made on delivery for the quantity delivered to the project site, up to planned quantity. Any amount delivered exceeding plan quantity will not be paid unless approved by the Engineer. This includes all rails, supports, ballast, hinge points, reflective sheeting, and miscellaneous hardware needed to install and maintain a barricade section.

MICHIGAN  
DEPARTMENT OF TRANSPORTATION  
  
SPECIAL PROVISION  
FOR  
**TEMPORARY PEDESTRIAN TYPE II CHANNELIZER**

COS:CRB

1 of 2

APPR:CAL:CT:02-05-21  
FHWA:APPR:02-17-21

**a. Description.** This work consists of delivering, installing, maintaining, relocating, and removing temporary pedestrian channelizers as identified in the proposal or on the plans. Use temporary pedestrian channelizers to guide pedestrians along a temporary non-motorized facility, and to create separation of pedestrians from construction areas near existing facilities. Replace damaged temporary pedestrian Type II channelizers as directed by the Engineer.

**b. Materials.** Provide a temporary pedestrian channelizer that is crashworthy in accordance with the *National Cooperative Highway Research Program Report 350* (NCHRP 350) or *Manual for Assessing Safety Hardware* (MASH), in addition to meeting the following requirements:

1. Ensure the channelizer is designed to interconnect to maintain continuous delineation along the entire installation. This includes provisions to accommodate non-linear alignment as well as variations in elevation.

2. Ensure the top surface of the channelizer is designed to function as a hand-trailing edge and have a height between 32 and 38 inches. Ensure this top surface is designed to have a 2 inch horizontal gap between the top edge and the support (if so equipped), to allow for continuous hand-trailing without obstructions. Ensure the lower edge of the channelizer is no more than 2 inches above the surface of the non-motorized facility. Ensure the top edge of the bottom rail of the channelizer is a minimum of 8 inches above the surface of the non-motorized facility or the channelizer may have a solid continuous face. Finally, all features on the front face of the channelizers (the face in contact with pedestrians) must share a common vertical plane.

3. Equip both sides of the channelizer with bands of alternating 6-inch wide orange and white vertical stripes of reflective sheeting. Two bands of sheeting 6 inches tall and a minimum of 36 inches long containing at least two orange and two white stripes each are required. One band placed near the top and one near the bottom if the channelizer section has a solid face. If the channelizer consists of two rails, affix one band of sheeting to each rail. Ensure the stripes of reflective sheeting are aligned vertically. Ensure this sheeting meets or exceeds the requirements of *ASTM D4956, Type IV* sheeting.

**c. Construction.** Deploy the temporary pedestrian Type II channelizer in accordance with the manufacturer's recommendations, the MMUTCD, the plans, and the following requirements:

1. Install the channelizer as shown on the plans and as directed by the Engineer. Interconnect all channelizers using hinge components if necessary, to ensure a continuous detectable edge for the entire installation. Ensure the channelizers are ballasted in accordance with the manufacturer's recommendations to ensure stability during wind events and contact with pedestrians.



2. When the channelizers are installed near motor vehicle traffic, ensure reflective sheeting is visible to motorists providing appropriate delineation for the pedestrian path.

3. If sections of multiple-colored barriers are used (i.e safety orange and white), install the sections such that the colors alternate to increase conspicuity.

4. Ensure temporary pedestrian Type II channelizers are not used to guide pedestrian traffic on a motor vehicle facility in the presence of active traffic. This prohibition includes bicycle/shared use lanes or shoulders in the presence of active traffic. Ensure temporary pedestrian channelizers are not used to channelize motor vehicle traffic, or separate motor vehicle and pedestrian traffic.

**d. Measurement and Payment.** The completed work, as described, will be measured and paid for at the contract unit price using the following pay item:

<b>Pay Item</b>	<b>Pay Unit</b>
Pedestrian Type II Channelizer, Temp.....	Foot

**Pedestrian Type II Channelizer, Temp** includes delivering, installing, maintaining, relocating and removing rails or wall sections, supports, ballast, and hinge points at the locations shown on the plans. Payment will be made on delivery for the quantity delivered to the project site, up to planned quantity. Any amount delivered exceeding plan quantity will not be paid unless approved by the Engineer. This includes all rails or wall sections, supports, ballast, hinge points, and miscellaneous hardware needed to construct the channelizer or system of channelizers.

CITY OF ANN ARBOR  
SPECIAL PROVISION  
FOR  
**RIPRAP, COBBLESTONE  
CHECK DAM, COBBLESTONE**

BBT:CED

1 of 2

4/2/24

**a. Description.** This work consists of installing heavy geotextile fabric and furnishing and placing fieldstone riprap for aprons, permanent check dams, and level spreaders as detailed on the plans. All work must be done in accordance with section 813 of the Michigan Department of Transportation (MDOT) 2020 Standard Specifications for Construction except where noted in this special provision and as directed by the Engineer.

**b. Materials.** Use stone for riprap that is washed, uncrushed, rounded cobblestone. Acceptance will be based on visual inspection of riprap in-place by the Engineer, in accordance with gradation requirements specified in Table 1.

**Table 1: Individual Stone Gradation Requirements  
for Riprap, Cobblestone**

Least Dimension, inches	Percent Smaller Than
24	100
20	85
16	50
8	15

Provide non-woven geotextile fabric meeting the requirements for pay item Geotextile, Separator, Non-Woven as specified in section 910 of the MDOT Standard Specifications. Furnish test data certification from the manufacturer on the specific product intended for use prior to installation.

**c. Construction.** Excavate existing material to the limits shown on the plans prior to placing heavy geotextile fabric and riprap. Place geotextile fabric on the prepared grades in accordance subsection 910.03.B of the MDOT Standard Specifications. Place riprap in accordance with subsection 813.03 of the MDOT Standard Specifications, on prepared grades to the elevations, thickness, and lateral limits as shown on the plans. Ensure that the installation of the riprap does not damage the geotextile fabric. Remove and replace all damaged geotextile fabric at no cost to the Department.

Start placement of riprap at the toe and proceed up the slope, with each stone firmly embedded into the slope and against the adjoining stones. Construct the riprap to minimize voids. If placed riprap contains large voids, the Engineer may direct the Contractor to place additional stones of smaller sizes to fill the voids. The finished surface of the riprap must present a tight, even surface.

**d. Measurement and Payment.** The completed work, as described, will be measured and paid for at the contract unit price using the following pay item:

<b>Pay Item</b>	<b>Pay Unit</b>
Riprap, Cobblestone .....	Square Yard
Check Dam, Cobblestone .....	Foot

**Riprap, Cobblestone** includes furnishing all labor, equipment, and materials necessary to clear and prepare grades, excavate and dispose of surplus materials, furnish and place geotextile fabric, and to place the stone, in accordance with the plans and this special provision.

**Check Dam, Cobblestone** includes furnishing all labor, equipment, and materials necessary to clear and prepare grades, excavate, and dispose of surplus materials, furnish and place geotextile fabric, place the stone in accordance the plan details and with this special provision. This pay item includes removal of cobblestone check dams if directed by the Engineer.

MICHIGAN  
DEPARTMENT OF TRANSPORTATION

SPECIAL PROVISION  
FOR  
**LIVE STAKING**

RSD:JRN

1 of 3

APPR:JLB:DWS:12-08-20

**a. Description.** This work consists of furnishing and installing live stakes in accordance with the plans and as directed by the Engineer in consultation with the MDOT Region Resource Analyst/Specialist. Work includes providing all labor and materials necessary to install the live stake cuttings.

Prior to installing any plant material, the Engineer will schedule an onsite meeting with the planting contractor and the MDOT Region Resource Analyst/Specialist.

Ensure the location of live stake types and spacing are as indicated below and as shown on the plans and are field reviewed by the Engineer in consultation with the MDOT Region Resource Analyst/Specialist prior to any planting activities.

**b. Materials.**

1. Live Stakes. Live stakes must be 1 inch to 2 inches in diameter and 2-6 feet in length depending upon site conditions to allow for 2/3 of the total stake length to be installed below the soil line. Use the following species and quantities for this project:

Cephalanthus Occidentalis (Buttonbush) .....	70 Each
Cornus Amomum (Silky Dogwood) .....	70 Each
Cornus Sericea (Red Osier Dogwood).....	70 Each
Physocarpus Opulifolius (Ninebark).....	70 Each
Salix Discolor (Pussy Willow).....	70 Each
Salix Sericea (Silky Willow).....	70 Each
Sambucus Canadensis (Elderberry) .....	70 Each
Viburnum Dentatum (Arrowwood).....	70 Each

Ensure plant material is from within the Michigan's physiographic eco-region and plant hardiness zone. Provide a source list for the live stakes to the Engineer at the preconstruction meeting. Once the source list has been approved, coordinate live stake delivery, inspection, and installation with the Region Resource Analyst/Specialist.

Supply live stakes tagged by the supplier and bundled by species. Ensure stakes are dormant at the time of harvest and planting. Provide supplier certification of the harvest location and harvest date.

2. Rooting Compound. Use a rooting compound to ensure root production on live stakes by supplying essential hormones needed for accelerated root development.

**c. Construction.**

1. Seasonal Limitations. Plant live stakes between November 15<sup>th</sup> and April 15<sup>th</sup> during the dormancy period.

2. Preparation of Live Stakes. Ensure the basal ends of the stakes are cleanly cut at a 45 degree angle or point to facilitate easy insertion into the soil. The top should be cut square or blunt 90 degree angle for tamping. Ensure all limbs and side branches are cleanly removed prior to installation with the bark intact.

3. Timing. Install live stakes within 5 days of cutting. Keep cuttings moist at all times. Outside storage locations should be continually shaded and protected from wind and direct sunlight. Soak live stakes in water a minimum of 24 hours prior to installation. Ensure stakes are planted the same day they are removed from water. Improper preparation, storage or handling of the live stakes will be cause for rejection.

4. Spacing. Stakes will be spaced approximately 3 feet on center. Final spacing and locations will be determined on site prior to installation.

5. Installation. For stakes located in the riprap areas use an iron stake or bar no larger than the diameter of the live stakes to make a pilot hole between the riprap. Prior to placement, use a rooting compound on stake end and follow manufacturer’s instructions. Tamp live stakes perpendicular into the finished bank slope with a dead blow hammer, with leaf buds oriented in an upward direction. Tamp stakes until approximately 2/3 of the stake length is within the soil below the riprap. Ensure a minimum of 2 live buds are exposed above the riprap. For stakes located outside the riprap areas tamp the soil around the stake and pack firmly after installation. Be careful not to damage the buds, strip the bark, or split the stake during installation. Ensure any stakes that are damaged during installation or are installed improperly are removed and replaced at no additional cost to the contract.

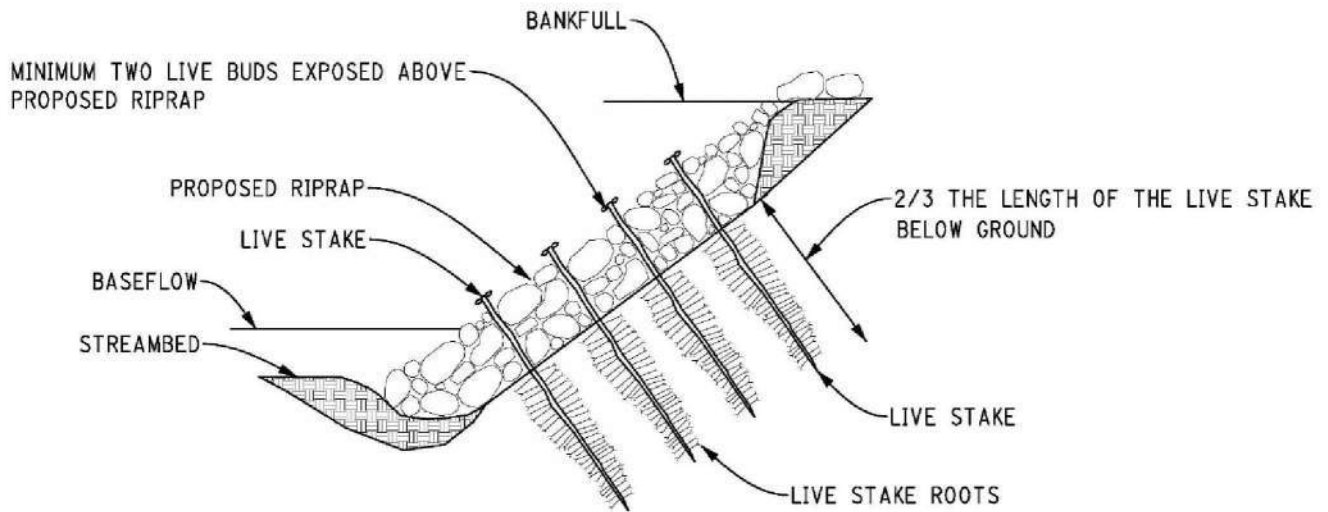
6. Watering and Cultivating. Watering and Cultivating as described in subsection 815.03 of the Standard Specifications for Construction will be waived for live staking.

7. Period of Establishment. The period of establishment as described in subsection 815.03.K applies to all live stakes for the first growing season only. Replace unacceptable stakes the following year before April 15<sup>th</sup>.

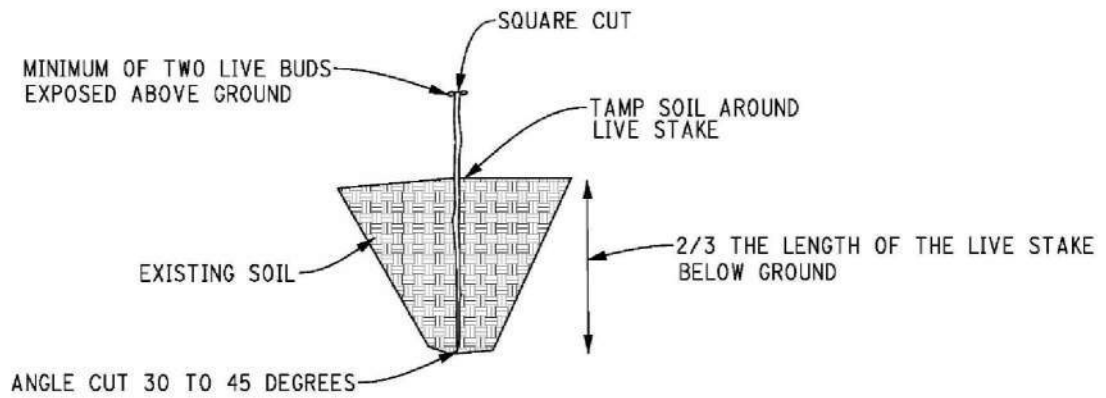
**d. Measurement and Payment.** The completed work, as described, will be measured and paid for in accordance with section 815 of the Standard Specifications for Construction using the following pay item:

<b>Pay Item</b>	<b>Pay Unit</b>
Live Staking.....	Square yard

**Live Staking** includes all site preparation, labor, equipment and materials required to complete the work, including proper storage of all plant material, as specified herein and as detailed on the plans.



LIVE STAKE JOINT PLANTING CROSS SECTION



LIVE STAKE CROSS SECTION

CITY OF ANN ARBOR  
SPECIAL PROVISION  
FOR  
**SEWER, PVC, 6 INCH, TRENCH DETAIL B**

BBT:CED

1 of 1

4/2/24

**a. Description.** This work consists of providing all labor, equipment, and materials for furnishing and installing polyvinyl chloride (PVC) drainage pipe at the locations and elevations shown on the plans.

**b. Materials.** Smooth-Wall Schedule 40 PVC Conduit. Provide smooth-wall PVC conduit, fittings, and accessories manufactured from PVC meeting the requirements of ASTM D1784 and the applicable NEMA TC2 and UL 651 requirements.

**c. Construction.** Perform trench construction using methods that meet the health and safety requirements specified in subsection 104.07 of the Standard Specifications for Construction.

Excavate the trench as shown on the plans or as determined by the Engineer. Construct the trench width to at least the minimum width shown in the MDOT Standard Plan R-83 series and wide enough to provide free working space and allow compaction of the backfill around the pipe. Shape the bottom of the trench to support the pipe uniformly. Place bedding using uncompacted granular material Class IIIA to the required elevation.

Where unstable soil conditions or obstructions other than rock require excavation of the trench below the elevation detailed on the plans, undercut, backfill, and compact the trench as directed by the Engineer. Use 6A, 17A, 34R, or 46G aggregate as backfill material for undercutting due to unstable soil conditions. Use 34R aggregate for bedding material instead of granular material Class IIIA. Place the backfill up to 4 inches below the proposed bottom of the pipe.

During sewer construction, maintain and protect existing live utilities. Minimize service interruptions and coordinate with the local municipality or utility company. Immediately repair or replace utilities interrupted during sewer construction as directed by the Engineer.

Backfill in accordance with subsection 401.03.D of the Standard Specifications for Construction.

Take possession and dispose of surplus material in accordance with subsection 205.03.P of the Standard Specifications for Construction.

**d. Measurement and Payment.** The completed work, as described, will be measured and paid for at the contract unit price using the following pay item:

<b>Pay Item</b>	<b>Pay Unit</b>
Sewer, PVC, 6 inch, Tr Det B .....	Foot

**Sewer, PVC, 6 inch, Tr Det B** will be measured in place from center to center of manholes, catch basins, or inlets. The unit price for **Sewer, PVC, 6 inch, Tr Det B** includes the cost of excavation and backfill.

CITY OF ANN ARBOR  
SPECIAL PROVISION  
FOR  
**TURF ESTABLISHMENT, PERFORMANCE**

BBT:CED

1 of 6

3/12/24

**a. Description.** For the work identified in this special provision paid for by the pay item Turf Establishment, Performance only, delete section 816 of the Standard Specifications for Construction and replace it with this special provision. The Contractor is responsible for the performance and quality of turf growth in the areas indicated on the plans and as identified by the Engineer. Comply with all local, state, and federal laws when completing this work.

Establish a durable, permanent, weed-free, mature, perennial turf. The work consists of fundamental turf work, including but not limited to topsoiling, seeding, mulching, erosion control, maintenance, watering, and repair of turf as described herein during the life of the contract and during the life of any supplemental performance bond which may ensue.

Choose and implement proven turf establishment industry practices; provide all necessary labor and equipment; select and provide all turf establishment materials; and control erosion and any subsequent sedimentation at all times.

Perform a site analysis, interpret the results and implement a turf establishment program to ensure compliance with this specification. The site analysis must take into consideration topsoil needs, fertilizer and pH requirements, seed mix, existing and future soil moisture levels, slopes and grades, required erosion control items and devices, maintenance requirements, local highway snow removal and deicing practices, and any other characteristics that influence and affect turf establishment.

Subsection 107.11 of the Standard Specifications for Construction is revised relative to the Contractor's responsibility for the repair of turf establishment work as follows. The Contractor is responsible, at no additional cost to the contract, for the repair of turf establishment work occasioned by storm events up to 3 inches of rain in a 24 hour period as documented by local meteorological data submitted to the Engineer for review and approval. All other portions of subsection 107.11 remain unchanged.

1. Contractor Turf Establishment Experience Requirements. Ensure weed control is done by a commercial herbicide applicator, licensed by the State of Michigan and certified by the Michigan Department of Agriculture (MDA) in the appropriate category to apply herbicides. Use application procedures and materials according to federal, state and local regulations. Use of restricted use chemicals is prohibited. Provide appropriate documentation and secure approval from the Engineer before application of herbicides.

At least 10 work days prior to start of turf establishment, provide documentation to the Engineer, from the Contractor performing the turf establishment work, that they meet one or both of the following requirements.

- A. At least one person employed by the Contractor performing the turf establishment work and assigned to the job site has a degree or certificate in Turf Management,



Horticulture, or a related field.

- B. At least one person employed by the Contractor performing the turf establishment work and assigned to the job site has at least five (5) years of experience in turf establishment and native plantings.

**b. Materials.** Provide topsoil, seed, mulch, pesticide, herbicide, mulch blankets and any other unique erosion control materials as necessary to fulfill this specification, as detailed on the plans. Use additional materials, as necessary, to meet the standards set forth for turf establishment in this special provision. The use of sod on the project requires the prior approval of the Engineer and if approved, may be used at limited site locations only.

Selection of all materials is the responsibility of the Contractor with the following minimum conditions.

1. Soil. Provide furnished or salvaged topsoil, which may be blended compost, that will support vigorous growth. Ensure topsoil is humus bearing and placed at least 4 inches deep. Ensure it is free of stones larger than 1/2 inch (2 inches on freeway projects) in diameter and other debris. Trim and grade the finished slope in accordance with subsection 205.03.N of the Standard Specifications for Construction.
2. Native Seed Mixes (Roadside and Shade). Native seed shall be obtained from sources within the same EPA Level III Ecoregion, or the next adjacent Ecoregion, preferably to the west or east. For more information, see the EPA website at: <http://www.epa.gov/wed/pages/ecoregions/leveliii.htm>
  - a. Utilize the seeding mixes listed below or an approved equal. Ensure seed is less than 1 year old and stored as recommended by the supplier. Provide documentation regarding the supplier's source with location, quantity, purity, and mix proportions to the Engineer at least 30 calendar days before application of seed mixture.
    - i. Mesic Woodland Mix: Mesic Woodland Mix: Prepared by Native Connections, Kalamazoo, MI, phone (269) 459-6900 or approved equal. No Purple Coneflower, Rattlesnake Master, Wild White Indigo or Rosin Weed shall be included in the seed mix.

Install native seed mixes in the areas as shown on the plans or as directed by the Engineer. No aggressive, threatened, endangered, or special concern species shall be in the seed mix. Species may be substituted through written approval by the Engineer.

Provide Temporary Cover Seed consisting of annual rye, winter wheat or other approved equivalent. Temporary cover seed shall be applied at a rate of 15 lb per acre over all disturbed areas, or as recommended in Seed Mixes. Temporary Cover Seed shall be mixed and applied with the large seed only in all native seed areas on the project site.

3. Turf Grass Seed. Use a seeding mixture that is composed of four (4) or more species of perennial grass. Use only species and their cultivars or varieties which are guaranteed hardy for Michigan.

Recommended species of perennial grasses include: Kentucky Bluegrass, Perennial

Ryegrass, Hard Fescue, Creeping Red Fescue, Chewings Fescue, Turf-type Tall Fescue, Buffalo grass, and Alkaligrass-Fults *Puccinellia distans*. Select cultivars or varieties of grasses that are disease and insect resistant and of good color. Ensure that no one species in the mix is less than 5 percent, or more than 25 percent, of the mixture by weight. Do not select grass species considered noxious or objectionable, such as Quack Grass, Smooth Brome, Orchard Grass, Reed Canary Grass and others.

- A. Ensure the seed is legally saleable in Michigan. Ensure the seed product does not contain more than 10 percent inert materials. Ensure the seed source is an MDOT approved certified vender.
  - B. Adapt the species and varieties of seed to the site conditions, to the site use, and to the soils, moisture, and local climate. Site use may include, but is not limited to, detention pond, wildlife habitat, playground, wetlands, forested wetland, rural roadside, urban roadside, and highly maintained front yard.
  - C. Ensure at least two of the species in the mixture proposed to be planted within 15 feet behind the curb or the shoulder are salt tolerant.
4. Mulch. Mulch seeded areas with slopes less than 1 on 3 with the appropriate materials for the site conditions to promote germination and growth of seed and to mitigate soil erosion and sedimentation.
  5. Mulch blanket. 6-foot mulch blanket shall be placed along the pathway and in areas where final grades have slopes greater than 1 on 3 or at the bottom of all proposed stormwater channels and swales. Provide straw mulch blanket with biodegradable jute netting. Anchor blankets in-place with wooden stakes.
  6. Herbicides. Comply with all federal, state and local laws. As part of the MDA weed control application, the Contractor is required to make proper notifications and/or postings as per label and MDA requirements for all locations that will be sprayed. Notify the Engineer at least 48 hours prior to any applications being made. Furnish and apply herbicide(s) needed. It is the Contractor's responsibility to select the herbicide(s) and the rate at which it is used. Obtain the Engineer's approval of work methods and herbicide(s) selected prior to the application of the herbicide(s). Complete a spray log and submit to the Engineer each day an application is made.

Do not draw water from any waterway (i.e. river, ditch, creek, lake etc.) located on state, county or municipal right-of-way, for mixing with herbicides.

7. Fertilizers. Furnish and apply fertilizer(s) as needed. It is the Contractor's responsibility to select the fertilizer(s) and the rate at which it is used. The use of phosphorus is strongly discouraged and is only allowed only when required by soil conditions. Obtain the Engineer's approval of work methods and fertilizer(s) prior to the application of the fertilizer(s).
  8. Water. Furnish and apply water from an approved source at a rate to promote healthy growth.
- c. Construction.** The Contractor is responsible for all work and all construction methods used in completing this work. Implementation of any part of the standard specifications or

standard plans by the Contractor does not relieve the Contractor of responsibility for acceptability of the construction methods or for the quality of the work.

1. Seed Placement. Ensure seed is set into the soil. Do not just broadcast seed without means of covering it in the soil. Raking after broadcasting seed is acceptable.
2. Inspection of the Work. The Contractor is responsible for all inspection of turf establishment work.

Use a Contractor's Daily Report, approved by the Engineer, to report inspections made and to document turf establishment work performed on this project. Complete and submit a Contractor's Daily Report to the Engineer when any work performed under this special provision is in progress.

Include all necessary materials documentation including tests slips, certifications, etc. with the associated Contractor's Daily Report.

The Engineer will determine the acceptability of the Contractor's Daily Report in terms of their completeness and accuracy. The Engineer reserves the right to verify all submitted measurements and computations. Failure by the Contractor to submit acceptable and timely reports to the Engineer may result in withholding of progress pay estimates on turf-related items until such time as reports are submitted and deemed acceptable.

The Engineer reserves the right to inspect the project for any reason in accordance with subsection 104.01 of the Standard Specifications for Construction, including the fulfillment of other inspection requirements such as Soil Erosion and Sedimentation Control, NPDES, etc. Inspections made by the Engineer do not relieve the Contractor of the responsibility for inspections required by this special provision or the Contractor's responsibilities for erosion control and turf establishment.

3. Erosion Control. Control erosion at all times according to section 208 of the Standard Specifications for Construction. Control of soil erosion is the responsibility of the Contractor. However, sedimentation controls must be placed as indicated on the plans or as directed by the Engineer. Continuously monitor the site for needed erosion repair from any cause as addressed in the contract. Return all eroded areas to original grade as detailed in the contract.

Take immediate corrective action if sedimentation occurs in drainage structures or any watercourse or water containment area and stabilize all disturbed areas contributing to this sedimentation within 24 hours after the erosion occurrence. Remove sediment deposited as a result of the Contractor's inability to control the soil erosion at the Contractor's expense.

Reimburse the Owner for any costs levied against the Owner, such as fines, environmental costs, costs for remedies required, or any other costs as a result of the Contractor's failure to comply with this special provision and with federal, state and local laws.

4. Erosion Repair. The Contractor is responsible for all repairs and liable for all consequences (legal, monetary or other) associated with erosion or sedimentation damage to finished or unfinished work.

Report all erosion occurrences and the repairs made by the Contractor to the Engineer in the format and at the frequency required by the Engineer. Repair any erosion, displacement or disturbance to ongoing or completed work by any cause at no additional cost to the contract unless otherwise noted herein.

The Contractor is responsible and liable for all traffic control and safety measures required to repair and protect damaged turf areas. Repair any eroded area that may affect the support of the roadbed or safety of the public within 24 hours of the erosion occurrence and notify the Engineer immediately.

Place protective devices such as barriers, directional signs/signals, temporary fence, or any other safety measures immediately after any erosion damage occurs that has the potential of endangering the public. In these instances, provide the Engineer with a written summary of the immediate action taken describing the repairs made and the safety measures taken, within 24 hours of the occurrence of the damage.

5. Mowing and Weeding. Maintain turf to a visually appealing level, and not more than 8 inches in height at any time, prior to acceptance. Weeds must be controlled to less than 10 percent of the turf establishment area at all times during construction.
6. Final Acceptance and Supplemental Performance Bond.
  - a. Final Acceptance Parameters. Before final acceptance of the turf establishment work, ensure all of the following minimum parameters are met throughout all exposed areas of the project designated on the plans or identified by the Engineer as turf establishment areas: there must be no exposed bare soil and the turf must be fully germinated, erosion free, weed free, disease free, dark green in color and in a vigorous growing condition.

The Engineer will notify the Contractor of the dates and times of all acceptance inspections. The Contractor may accompany the Engineer during these inspections. If the Contractor does not agree with the decision made by the Engineer, the Contractor may request an inspection by a mutually agreed upon third party (Michigan State University Extension service or other). A joint inspection, to include the Engineer, the Contractor, and the third party, will be scheduled by the Engineer. The Contractor shall pay all expert fees and expenses charged by the third party.

- b. Supplemental Performance Bond. In the event that all contract items of work are completed, including the placement of all turf establishment items of work, and the final acceptance of the project is delayed because the final acceptance parameters for the turf establishment work have not been fully met; the Contractor may propose to the Engineer the use of a supplemental performance bond.

The bond serves to secure the successful completion of turf establishment work and fulfillment of all final acceptance parameters for the turf establishment work. Ensure the supplemental performance bond, in all respects, is satisfactory and acceptable to the Owner and executed by a surety company authorized to do business with the State of Michigan.

Ensure the bond is in an amount equal to 50 percent of the turf establishment work

items covered by this special provision. Ensure the bond remains in place for two (2) growing seasons. At the discretion of the Engineer, the bond may be reduced on a prorated basis as portions of the areas designated for turf establishment on the project meet the final acceptance parameters.

**d. Measurement and Payment.** The completed work, as described, will be measured and paid for at the contract price using the following pay item:

<b>Pay Item</b>	<b>Pay Unit</b>
Turf Establishment, Turf Grass, Performance.....	Square Yard
Turf Establishment, Native Seed Mix, Mesic Woodland Mix, Performance ....	Square Yard

**Turf Establishment, \_\_\_\_\_, Performance** will include all labor, equipment and materials required or selected by the Contractor to install, maintain, inspect, repair and meet the acceptance parameters for turf establishment specified in this special provision, including preparation, updating and submittal of the Contractor’s Daily Reports.

Limits of turf grass and native seed mixes to be determined in the field by the Engineer. Approximate limits are as follows:

Turf Grass – Station POB to POE within 5-feet of edge of path to limits of grading, whichever is less.

Mesic Woodland Mix – Station POB to POE beyond the limits of the Turf Grass noted above and from Sta 140+94 to the start of the permanent sheet piling wall.

Repairs made to damaged turf establishment areas as a result of a documented storm by local meteorological data resulting in rainfall amounts of more than 3 inches in a 24 hour period will be paid for as an increase to original quantities in accordance with subsection 109.05 of the Standard Specifications for Construction.

The following schedule of payment applies to work performed according to this special provision. Upon completion of seed, fertilizer, and mulch, 50 percent of the final field measured amount for **Turf Establishment, \_\_\_\_\_, Performance** will be paid to the Contractor. The remaining 50 percent of the final field measured amount will be paid upon completion of all other work necessary to comply with this special provision and to meet all final acceptance parameters for **Turf Establishment, \_\_\_\_\_, Performance** or at such time as the supplemental performance bond is accepted by the Owner.

The supplemental performance bond and all costs associated with turf establishment work performed during the duration of the performance bond will not be paid for separately. These costs which may include, but are not limited to, mobilization, traffic control devices, and the required permit insurance are included in the unit price bid for **Turf Establishment, \_\_\_\_\_, Performance**.

CITY OF ANN ARBOR  
SPECIAL PROVISION  
FOR  
**DECORATIVE LIGHT STANDARDS**

BBT:CED

1 of 2

3/8/24

**a. Description.** This work consists of furnishing and installation of light standard shafts, arms and luminaires as shown in the contract. Perform this work in accordance with the requirements of section 819 of the Standard Specifications for Construction, the *NEC*, as specified herein, and as detailed on the plans.

**b. Materials.** Provide material in accordance with subsection 819.02 of the Standard Specifications for Construction except as specified herein. Materials must meet all applicable code requirements of the *ANSI/NEMA/UL* Standards. Provide the following for this project:

1. Decorative Luminaires. Ensure the luminaire housing and optical assembly is provided by the same manufacturer.

Ensure the luminaire does not exceed 50 watts of power and is light emitting diodes (LED) operating at 120 volts as shown on the plans. Ensure the LED fixture has a color temperature of 4000 kelvin (K) ( $\pm 250K$ ), with a color rendering index (CRI) of 70 or greater, internal surge suppression module, and is designed to operate at a temperature range of -40 degrees Fahrenheit (F) to 105 degrees F. Ensure luminaire efficiency is 90 percent or better and has a L70 life expectancy rating of at least 55,000 hours of operation at 25 degrees Celsius (C) and 500mA based on *IES-LM-80* calculated.

Ensure the luminaire is (*IEC IP65* rated) extruded aluminum construction for Type A, B, and C series and copper-free precision die-cast aluminum construction for type D series with stainless steel or zinc plated steel fastening hardware suitable for wet locations. The fixture must have a remote (or interval), weather-tight LED drive located in the pole. No active cooling features (fans, etc.) will be allowed. The luminaire finish must be black for Type A, B, C, and D series.

The luminaire must have a minimum 5-year manufacturer's written warranty covering luminaire assembly, electrical components, driver, mechanical components and paint finish.

Refer to drawings for luminaire types.

2. Decorative Shaft. Ensure the shaft is one aluminum piece. The design of the light standard must include the design of the shaft required to support light fixtures or other ancillary items, including a photocell attached to the shafts. The shaft and ancillary items finish must be black.

Submit design calculations, including reactions to the foundations, and detailed working drawings to the Engineer's for review and approval prior to manufacturing.

**c. Construction.** Submit certifications, working drawings and design calculations to the Engineer for review and approval not less than 14 days prior to the start of the work. Do not start fabrication until the Engineer approves the working drawings.

Ensure all light standard assemblies are provided by one manufacturer. Any proposed luminaire must achieve the photometric levels and uniformity ratios per *IES LM-79* for the fixture spacing as shown in the contract, and must be submitted with project specific point by point lighting foot-candle calculations by an independent third party testing lab, meeting the following design criteria:

1. Average maintained illumination level must not be less than 3 foot-candles with a uniformity ratio (Average/Minimum Foot-candles) not exceeding 35:1 for the path being lit.

Install light standards and luminaires in accordance with subsections 819.03.G and 819.03.H of the Standard Specifications for Construction respectively. Install the light standard and luminaire on the foundation according to the manufacturer's recommendation. All electrical connections must meet the *NEC* requirements and any applicable local electrical codes.

Repair any damages to product per subsection 819.03 of the Standard Specifications for Construction. Any repair costs incurred for the repairs are the responsibility of the Contractor.

**d. Measurement and Payment.** The completed work, as described, will be measured and paid for at the contract unit price using the following pay items:

<b>Pay Item</b>	<b>Pay Unit</b>
Luminaire, Wall Mount, Type (A) .....	Each
Luminaire, Decorative, Type (B) .....	Each
Luminaire, Decorative, Type (C) .....	Each
Luminaire, Pole Mount, Type (D) .....	Each
Light Pole, Type (D Pole) .....	Each

1. **Luminaire, Wall Mount, Type (A)** includes furnishing and installing the complete luminaire including the associated hardware and wiring.
2. **Luminaire, Decorative, Type (B)** includes furnishing and installing the complete luminaire including the associated hardware and wiring.
3. **Luminaire, Decorative, Type (C)** includes furnishing and installing the complete luminaire including the associated hardware and wiring.
4. **Luminaire, Pole Mount, Type (D) and Light Pole, Type (D Pole)** includes furnishing and installing the complete luminaire and shaft including the associated hardware, photocell and wiring.

The foundation for the light standard will be paid for separately.

CITY OF ANN ARBOR  
SPECIAL PROVISION  
FOR  
**ELECTRICAL UTILITY SERVICE**

BBT:CED

1 of 1

3/8/24

**a. Description.** This special provision contains the requirements for arranging and paying fees for the installation of electrical service on this project.

**b. Materials.** None specified.

**c. Requirements.** As soon as the contract is awarded, the Contractor must apply to the utility company shown below to have new, 120/240 volts, 3 wire, single phase secondary service installed at the location shown on the plans. No additional payment will be allowed by the Contractor because of any delay caused by the electrical service not being completed. The Engineer will sign all application forms for DTE.

Utility Company: Detroit Edison Co.  
One Energy Plaza, Room 427 SB  
Detroit, MI 48226-1221

Contact Person: Stephen McClear  
(734) 397-4115

**d. Measurement and Payment.** The completed work, as described, will be measured and paid for at the contract unit price using the following pay item:

<b>Pay Item</b>	<b>Pay Unit</b>
Electrical Utility Service.....	Dollar

**Electrical Utility Service** includes an estimated dollar amount for the electrical power feed to provide and install all necessary electrical equipment cable from the power provider's source to the meter. There will be only one power source installed on this project. **Electrical Utility Service** includes all costs associated with the service installation and all payments for any fees paid. The payments must be documented by an invoice such that reimbursement by the Department can be completed. No payment will be made until all the requirements mentioned herein are completed and the appropriate invoices are submitted and approved.



CITY OF ANN ARBOR  
SPECIAL PROVISION  
FOR  
**FIBER OPTIC AND TELECOM UTILITY WORK**

BBT:CED

1 of 2

3/8/24

**a. Description.** This work consists of providing all labor, materials and equipment necessary to complete the utility coordination and utility work, and provide protection, for facilities owned by Lumen and Amtrak on this project.

This work consists of protecting existing conduits within the work zone, constructing and removing any temporary conduit support systems, and coordinating with the fiber optic cable owners throughout construction for moving their cables during construction.

This work also consists of providing access for the utility owners to the project site and coordinating railroad flagging during their work throughout construction.

**b. Materials.** Use materials in accordance with the standard specifications and as specified herein.

**c. Construction.** Provide temporary protection, temporary support, and coordinate with fiber optic cable crews for moving their lines during construction:

1. Lumen: 2-1 ½ inch diameter conduits buried south of the existing railroad tracks.
2. Lumen: 2-2 inch diameter conduits buried north of the railroad tracks.
3. Amtrak: 1-1 ½ inch diameter conduits buried north of the existing railroad tracks.

Coordinate with affected utility companies a minimum of 2 weeks prior to starting work. Arrange for utility field representative to be present during construction in the vicinity of the facilities.

All costs to repair damage to utility facilities caused by the construction of this project are to be borne by the Contractor.

Develop a self-supporting protection system and construction staging sequence for excavation, placing culvert pieces, and backfilling, in coordination with each utility, which will fully protect the conduits at locations that are susceptible to damage. Submit the proposed self-supporting protection system in writing to the Engineer and each utility for review and approval a minimum of 30 working days prior to starting work.

The temporary support method must maintain the existing conduits at the existing elevation, or as approved by the facility owner, without sags or damage. Coordinate with the appropriate utility and obtain the approval of the Engineer prior to starting work. Proposed supporting method must be submitted in writing to the Engineer for review and approval a minimum of 30 working days prior to starting work.

Once placement and backfilling of culvert pieces are complete and are ready for relocating the utilities over top of it, coordinate with the utility owner a minimum of 3 working days prior to needing the facility moved in order to proceed with culvert installation. The utilities will be protected by permanent steel sleeves once they are placed in their final positions which will be furnished and completed by the utility owner.

**d. Measurement and Payment.** The completed work, as described, will be measured as a lump sum and paid for at the contract price using the following pay items:

<b>Pay Item</b>	<b>Pay Unit</b>
Utility Work, Lumen .....	Lump Sum
Utility Work, Amtrak .....	Lump Sum

Costs associated with railroad flagging will be paid for separately. **Utility Work, \_\_\_\_\_** includes all costs associated with coordinating with each utility owner as well as furnishing, designing, erecting, installing, and removing temporary support systems. Payment includes all required utility relocations for construction of the project necessary for staging construction to complete the work. Protective pipe used in the final location will be furnished and installed by the utility owner.

CITY OF ANN ARBOR  
SPECIAL PROVISION  
FOR  
**LIGHTING CONTROL PANEL**

BBT:CED

1 of 2

3/8/24

**a. Description.** This work consists of furnishing all materials, equipment and labor to furnish and install a new lighting control panel as shown on the plans and as specified herein.

**b. Materials.**

1. Lighting Contactor. Provide an electrical lighting contactor in a *NEMA type 4X*, 316L rated enclosure, equipped with a hasp to padlock in either the "Off" or "On" position. Provide a hasp of a size to accommodate a No. 1 Master Lock shank.

Provide 240 volt (V) rated, one phase, 20 ampere rated electrical lighting contactors as shown on the plans and actuated by photoelectric control. Equip the lighting contactor with a hand-off-automatic switch.

Provide a photoelectric control to properly operate the lighting control switch. Include a time delay to prevent operation by short time lighting such as lightning flashes and provide fail-safe operation so that upon failure of any part of the control to function the lights will turn on and stay on. Select and adjust the entire system so that there is no cycling due to the photoelectric control being turned off by the street lighting.

2. Circuit Breakers. Provide an approved circuit breaker with thermal-magnetic trip. Provide breaker handle positions that indicate "On" and "Off" conditions. Ensure voltage between any two conductors does not exceed the voltage rating of the circuit breaker.

3. Fused Disconnect Switch. Provide a fused disconnect switch in a *NEMA type 4X*, 316L rated enclosure equipped with a hasp to padlock in either the Off or On position. Provide a hasp of a size to accommodate a No. 1 Master Lock shank.

Provide fused disconnect switches that are three-wire, 2-pole, 600V rated, single phase and have the designated ampere rating shown on the plans.

4. Transient Voltage Surge Suppressors (TVSS). Provide TVSS unit rated for 160 kiloampere (kA) at 120/240V single phase, connected to the mains of the control panel.

5. Terminal Block. Provide terminal blocks in *NEMA type 4X*, 316L rated enclosure equipped with a hasp to padlock. Provide a hasp size to accommodate a No. 1 Master Lock shank.

Provide terminal blocks to accommodate aluminum conductor sizes up to #2/0 American Wire Gauge (AWG). Install the terminal blocks enclosure under the lighting control panel.

Per Voltage Drop Calculation. Ensure that if a branch circuit requires conductor sizes larger than allowed for circuit break terminal, a terminal block enclosure is used to decrease the

oversized conductors before entering the lighting control panel as indicated on the plans.

**c. Construction.** Install the lighting control panel as shown on the plans. Contact DTE - Electric and arrange to pick up, transport, and then install a meter enclosure as indicated on the plans.

The contractor shall provide 2" continuous slotted channel to mount panels. Posts shall be embedded in concrete 6'-0" deep. A Unistrut shall be installed horizontally to mount electrical gear.

**d. Measurement and Payment.** The completed work, as described, will be measured and paid for at the contract unit price using the following pay item:

<b>Pay Item</b>	<b>Pay Unit</b>
Lighting Control Panel .....	Each

**Lighting Control Panel** includes furnishing all labor, materials and equipment as specified herein and/or as shown on the plans to install a new lighting control panel to make a complete operating unit to control the operation of the lighting along the path and inside the tunnel. The pick-up, transport, and installation of the meter enclosure is included in this pay item and will not be paid for separately.

**Lighting Control Panel** includes all incidental items required for a finished and complete installation even though such items are not indicated on the drawings or specified herein. The work includes, but is not limited to, furnishing and installing circuit breakers, ground rod and ground wire, galvanized steel conduit, lighting contactors, fused disconnect switch on support steel, galvanized support steel, 4X4 wood posts, concrete footings, photoelectric cell NEMA type 4x enclosures, TVSS Unit, and terminal blocks.

MICHIGAN  
DEPARTMENT OF TRANSPORTATION

SPECIAL PROVISION  
FOR  
**RAILROAD TRACK MONITORING – AMTRAK FOR BARTON BANDEMER TUNNEL**

JAK:JRP

1 of 13

APPR:JLD:DBP:03-04-24

**a. Description.** This work consists of furnishing all necessary labor, materials and equipment to monitor railroad track movement including recording track geometry data before, during, and after construction to ensure construction activities do not impact the stability of the track as defined in Attachment A, Amtrak Engineering Practices No. 2031 (as amended until issuance of Amtrak Permit to Enter).

**b. Materials.** None specified.

**c. Construction.** Perform track monitoring during any excavation, sheet piling installation or modifications, boring or compaction activities that occur within the influence line of the track as defined in Amtrak Engineering Practices No. 2031, section 3.

1. Track Monitoring Plan. Submit track monitoring plan as defined in Amtrak Engineering Practices No. 2031, section 4.1.

2. Safety. Contractor personnel performing track monitoring are classified in the Amtrak permit as Roadway Workers. Perform the training requirements for Roadway Worker Protection specified in the Amtrak permit.

3. Control Points. Establish and maintain a minimum of 3 control (reference) points outside of the influence zone of project construction activities. Establish vertical and horizontal positional values relative to the project datum on these points. Preserve control points throughout the duration of the project.

4. Remote Monitoring Points. Establish remote monitoring points as defined in Amtrak Engineering Practices No. 2031, sections 2 and 3.

5. Monitoring. Monitor points each day as defined in Amtrak Engineering Practices No. 2031, section 5.2. Record point measurements and compare to previous recorded measurements. Measure all points each time monitoring occurs, except for the points 200 feet away from the end of work; these points only need to be measured if any of the other measurements exceeds an allowable deviation. Submit daily reports to the Engineer and Amtrak personnel as defined in Amtrak Engineering Practices No. 2031, section 5.3.

6. Allowable Deviations. If the track is found to have moved either vertically or horizontally by more than the allowable limits as defined in Amtrak Engineering Practices No. 2031, section 5.4, cease work immediately, and contact the designated Amtrak Project Engineer. Resume work after the site has been inspected and approved by Amtrak.

7. Track Maintenance. Deficiencies in track surface and alignment caused by construction activities are corrected by Amtrak forces at the Contractor expense as defined in

Amtrak Engineering Practices No. 2031, section 1, subsection 1.3.

**d. Measurement and Payment.** The completed work, as described, will be measured as a lump sum and paid for at the contract price using the following pay item:

<b>Pay Item</b>	<b>Pay Unit</b>
Railroad Track Monitoring.....	Lump Sum

**Railroad Track Monitoring** includes furnishing all the necessary material, labor, and equipment for the monitoring of rail movement during all construction operations requiring inspection and will be paid as a lump sum. No additional compensation for idled equipment, replacement equipment, or lost production due to train movements or settlement and subsequent work required to stabilize the rail will be allowed. All work done by Amtrak to repair deficiencies in track surface and alignment caused by construction activities are included in this pay item.


TITLE <b>TRACK MONITORING FOR WORK DISTURBING ROADBED</b>	ORIGINAL ISSUE DATE <b>11/14/2019</b>	NUMBER <b>2031</b>
	REVISED DATE <b>na</b>	PAGE <b>2 OF 12</b>
<ul style="list-style-type: none"> <li>• Gather, recording, and report track geometry data at pre-determined time intervals during construction.</li> <li>• Comparing pre-construction and during-construction data to determine if differential movement has occurred.</li> <li>• Report track monitoring data and comparison to Amtrak Construction Project Manager, Assistant Division Engineer of Track, and System Track Contracting Office Technical Representative (COTR).</li> <li>• Pay for any repairs required if track movement meets or exceeds 3/8-inch in any direction or creates conditions exceeding track geometry maintenance limits as defined in the MW1000 for the class of track concerned.</li> </ul> <p>Amtrak responsibilities:</p> <ul style="list-style-type: none"> <li>• Amtrak will identify and provide contact information for the following: System Track COTR for track monitoring, the Assistant Division Engineer of Track responsible for maintenance, and the Construction Project Manager.</li> <li>• Prior to construction Amtrak will review/approve the submitted Track Monitoring Plan.</li> <li>• Schedule Track Inspector to cover the anticipated duration of roadbed disturbing work.</li> <li>• Monitor track movement and prescribe repairs, restrictions, or removal tracks from service to ensure the safety of train operations.</li> </ul> <p><b>2. METHODS &amp; MATERIALS</b></p> <p><b>2.1. Surveying Requirements</b></p> <p>Surveyor in charge of performing track monitoring must be working under the direct supervision of a professional land surveyor duly registered in the state. Contract Surveyors must have working knowledge of Amtrak Survey Specification and have current Contractor Orientation Training credentials.</p> <p>Datum and accuracy will be in accordance with Amtrak Land Surveying Standards and Procedures Manual, Version 2.0:</p> <p>Datums – NAD 83 with appropriate UTM Zone - NAVD 88                  All coordinates in US survey feet.                  Horizontal and vertical accuracy 0.01-feet (1/8-inch) for all reports.</p> <p>Control must be verified before and during construction with frequency sufficiency to ensure continued accuracy.</p> <p><b>2.2. Equipment Requirements</b></p> <p>Monitoring shall be performed by a total station instrument having a minimum angular accuracy of 1-second and an electronic distance measurement accuracy of 1.0mm + 2ppm. Total station will locate Remote Monitoring Points (RMPs) located on the track to be monitored.</p>		

<b>TITLE</b>  <b>TRACK MONITORING FOR WORK DISTURBING ROADBED</b>	<small>ORIGINAL ISSUE DATE</small> <b>11/14/2019</b>	<small>NUMBER</small> <b>2031</b>
	<small>REVISED DATE</small> <b>na</b>	<small>PAGE</small> <b>3 OF 12</b>

Points should be either commercially available calibrated reflective targets or small prisms. All targets shall be mounted a uniform elevation below top of rail.

- Reflective targets shall be less than 3-inches square and affixed by adhesive to the web of the rail (as shown). Common types are shown in figure 1 but are not exclusive. Minimum angle of 30° from instrument to target face is allowed. Therefore, multiple target types may be used to aid in visibility from the instrument. During application the rail should be spot cleaned and dried to allow good adhesion.
- Small precise prisms shall remain at least 1-inch below the top of rail. They are typically on a bracket clamped to the base of the rail and must not interfere with track components.



### 3. MONITORING POINT LOCATIONS

#### 3.1. General Instructions

Benchmarks to be occupied including foresights and back sights, shall be outside of the ZOI for the roadbed disturbing work.

RMPs will be installed as pairs, with one target on each rail of the track to be monitored. The pairs shall be set perpendicular to the direction of the rails to allow for measurement of cross-level.

Pairs of RMPs will be spaced along the rails at 15.5-foot intervals. In locations of special track work (i.e.-turnouts, crossings, and miter rails) the System Track COTR will determine an alternate arrangement.

#### 3.2. Underground Crossing Work

This method for RMPs is applicable for underground work that enters Zone 3 shown on Figure 2 and/or crosses under the tracks.

Determine the Zone of Influence for the underground crossing work at the elevation of the bottom of railroad tie. Calculate by taking the diameter or width of the underground work, extending to the ground surface at the soil angle of repose. Soil angle of repose should be taken from soil borings performed at the crossing location that cover the depth from track level to the depth of underground work. If soil boring data is not available or does not satisfy the System Track COTR, use 20° as a conservative soil angle of repose. See Figure 2 for an example.

In each direction starting from the intersection of the centerlines of underground work and track, place RMPs every 15.5-feet until the monitoring point pairs are outside the Zone of Influence. Continue the RMPs for five pairs outside of the ZOI for a tie-in with undisturbed track. Refer to Figure 3 for an example.

#### 3.3. Work Parallel to Track

This method for placing RMPs is applicable for underground work that enters either Zone 2 or Zone 3 from figure 2, that does not cross under the tracks.



<b>TITLE</b>  <b>TRACK MONITORING FOR WORK DISTURBING ROADBED</b>	<small>ORIGINAL ISSUE DATE</small> <b>11/14/2019</b>	<small>NUMBER</small> <b>2031</b>
	<small>REVISED DATE</small> <b>na</b>	<small>PAGE</small> <b>4 OF 12</b>

Determine the Zone of Influence for the underground crossing work at the elevation of the bottom of railroad tie. Calculate by taking the lowest elevation limits of the underground work, extending to the ground surface at the soil angle of repose. Soil angle of repose should be taken from soil borings performed at the crossing location that cover the depth from track level to the depth of underground work. If soil boring data is not available or does not satisfy the System Track COTR, use 20° as a conservative soil angle of repose. See Figure 4 for an example.

Any place the ZOI intersects Zone 2 from Figure 1 requires monitoring for the track directly perpendicular to the intersection of ZOI and Zone 2. In each direction, place RMPs every 15.5-feet until the RMP pairs are outside the Zone of Influence. Continue the RMPs for five pairs outside of the ZOI for a tie-in with undisturbed track. See Figure 5 for an example.

**4. PRECONSTRUCTION ACTIVITIES**

**4.1. Track Monitoring Plan Submittal**

Track Monitoring Plan shall be submitted a minimum of 4-weeks prior to commencement of roadbed disturbing work. The System Track COTR will review and provide comments or approval. As a minimum, the package must include the following:

- Information on the registration and experience of the field surveyor in charge performing the track monitoring.
- Design specifications of the total station instrument to be used, including angular accuracy and distance measurement accuracy.
- Design specifications of the prisms or targets to be used. Include information on adhesives, if used.
- Plan views, cross sections, profile views, or diagrams showing the roadbed disturbing work and the relation to the Zones shown in Figure 1. Include soil boring logs and laboratory data related to the project site.
- Detailed plan showing control locations in relationship to the tracks, roadbed disturbing work, and zone of influence. Include details on methods and frequency of control verification.
- Detailed Track Monitoring Plan view showing the location of all RMP locations, control points to be occupied during monitoring, the ground disturbing work and the ZOI. Each RMP must be numbered, with the hundredth being the track number, even numbered points on right rail, odd numbered points on left rail in the direction of increasing milepost. See Figure 6 for an Example Track Monitoring Plan.

**4.2. Contractor Safety Training**

All contractors that work on Amtrak owned or leased property are required to complete Amtrak’s Contractor Orientation Training available at: [www.amtrakcontractor.com](http://www.amtrakcontractor.com)

Contractor identification badges must be worn / displayed on the outermost garment, above the waist, always while on Amtrak owned or leased property.

<b>TITLE</b>  <b>TRACK MONITORING FOR WORK DISTURBING ROADBED</b>	<b>ORIGINAL ISSUE DATE</b> <b>11/14/2019</b>	<b>NUMBER</b> <b>2031</b>
	<b>REVISED DATE</b> <b>na</b>	<b>PAGE</b> <b>5 OF 12</b>

**5. CONSTRUCTION**

**5.1. Track Inspector**

Amtrak person having current qualifications in MW1000 and Physical Characteristics for the area work is being performed. Can inspect track and repair, restrict, or remove track form service if necessary.

Must be on-site when the leading end of work enters Zone 2 as shown on Figure 1 or as directed by the System Track COTR. Shall remain on-site until the completion of roadbed disturbing work, including reaming and pullback operations of horizontal directional drilling as defined by EP3005 Spec. 02082.

The Track Inspector will be provided at the sole cost of the project.

Will restrict or remove track form service if necessary, based on the MW1000 standards of track geometry for the class of track(s) involved. The Track Inspector has the authority to halt construction at any time should construction activities jeopardize the safe movement of trains over the work area.

**5.2. Monitoring Procedures**

Initial baseline reading of all monitoring points shall be recorded within ten (10) to five (5) days prior to construction. During the initial baseline readings, the offset from top of rail to the target shall be recorded for use in Track Monitoring Reports.

During construction, track monitoring shall start when the leading end of work enters Zone 2 as shown on Figure 2 or as directed by the System Track COTR. All RMPs shall be measured and recorded each time monitoring occurs.

Monitoring shall be performed at the beginning and end of every work shift, a minimum of twice daily (12-hour intervals). If track geometry meets or exceeds 0.03-feet (3/8-inch) of movement in any direction, monitoring must be performed every 4-hours until roadbed disturbing work is complete.

After roadbed disturbing work is complete, measurements will continue once a day until movement less than 0.01-feet (1/8-inch) has been observed for 5 consecutive days. Field conditions may warrant additional RMPs or extending the duration of post-construction monitoring as directed by the Track Inspector or System Track COTR.

**5.3. Communication**

Track Monitoring Report shall be produced immediately after each monitoring event. Measurements shown will be based on top-of-rail elevations based on the offset measured during initial setup. This will include total displacement of each RMP and cross level between RMP pairs.

Track Monitoring Reports must be signed and sealed by the surveyor in charge and cross-signed by the Track Inspector during work requiring their presence on-site. See Figure 6.7 for a sample Track Monitoring Report. The quickness of reporting track conditions is paramount to the safety of Amtrak operations.

An online sharing platform, such as Microsoft SharePoint Excel or Google Drive Sheets, must be set up and utilized by the contractor to immediately host the track monitoring data. A read-only link must be made available to the System Track COTR for distribution to Amtrak personnel as necessary. This real-time access will allow Amtrak's engineers to track movement and plan corrective action, if required.

<small>TITLE</small>  <b>TRACK MONITORING FOR WORK DISTURBING ROADBED</b>	<small>ORIGINAL ISSUE DATE</small> <b>11/14/2019</b>	<small>NUMBER</small> <b>2031</b>
	<small>REVISED DATE</small> <b>na</b>	<small>PAGE</small> <b>6 OF 12</b>

**5.4. Remediation Procedures for Track Movement**

- As a reminder: any person MW1000 qualified can restrict or remove a track from service based on track geometry conditions. Any person can stop the work and trains should construction activities jeopardize the safe movement of trains over the work area.

Deficiencies in track surface and alignment caused by construction activities shall be corrected solely by Amtrak forces.

If track is measured to have met or exceeds the track geometry maintenance limits as defined in the MW1000 for the class of track concerned or moves 0.03-feet (3/8-inch) displacement from baseline in any direction, then all work shall cease immediately. The following two items must be undertaken:

- The Track Inspector must immediately inspect the track geometry and take any corrective action that may be required per MW1000.
- The contractor must immediately and continuously attempt to notify the Amtrak Construction Project Manager, Assistant Division Engineer of Track, and System Track COTR of the deviations and confirm that corrective action is being taken on-site.

It is assumed that subsidence will continue, and corrective actions should be taken before track geometry exceeds the safety limits set forth in MW1000.

Any repairs made to correct track geometry will be made at the sole cost of the contractor.

**5.5. Construction Re-Start**

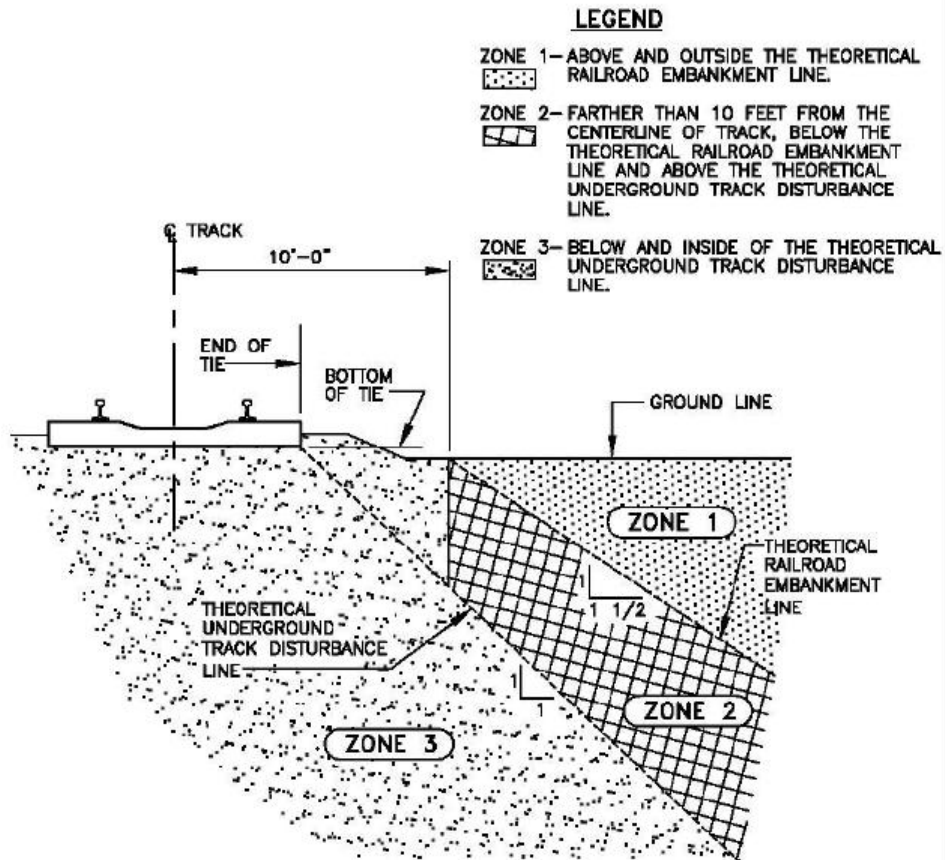
Work may not resume until the track inspector has inspected all tracks within the limits of disturbance and completed any appropriate action to repair, restrict, or remove the tracks from service. In addition, one of the following requirements must be met:

- If no further subsidence is expected, the Construction Manager must inspect the site and taken corrective action to ensure continued construction actives will not cause further track issues to the satisfaction of the System Track COTR.
- If further subsidence is expected, the Construction Manager, Assistant Division Engineer, and System Track COTR should agree on how to best protect train operations. Any further actions required to ensure the safe passage of trains, such as increased frequency of track monitoring, shall be at the sole expense of the contractor.

TITLE <b>TRACK MONITORING                  FOR WORK DISTURBING ROADBED</b>	ORIGINAL ISSUE DATE 11/14/2019	NUMBER 2031
	REVISED DATE na	PAGE 7 OF 12

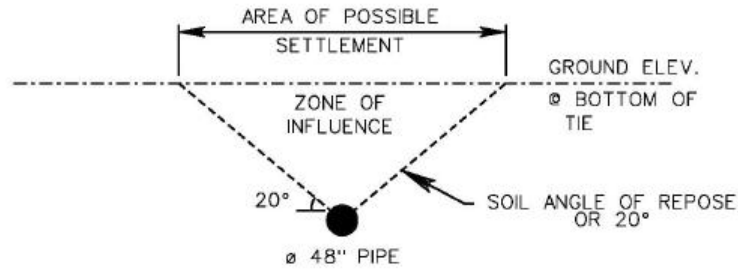
**6. FIGURES AND EXAMPLES**

Figure 1, Zones of Influence under track (from Structures EP 3014)

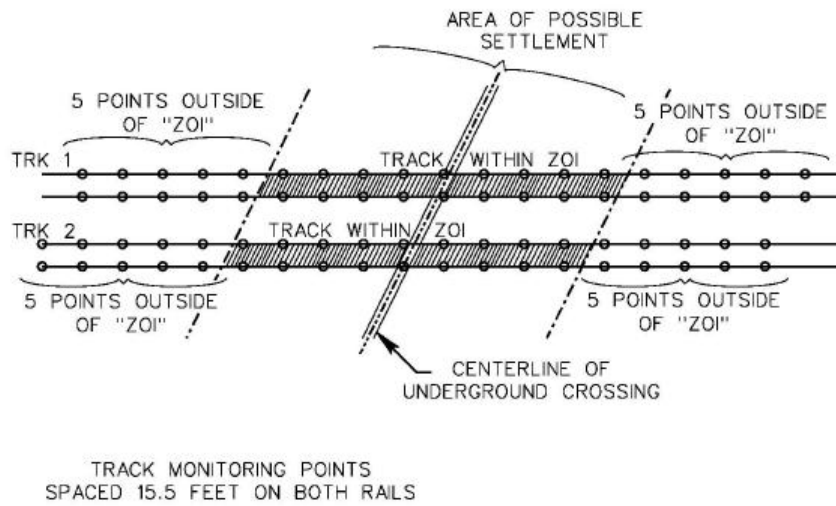


<b>TITLE</b>  <b>TRACK MONITORING FOR WORK DISTURBING ROADBED</b>	<b>ORIGINAL ISSUE DATE</b> 11/14/2019	<b>NUMBER</b> 2031
	<b>REVISED DATE</b> na	<b>PAGE</b> 8 OF 12

**Figure 2, Section View of Underground Crossing**

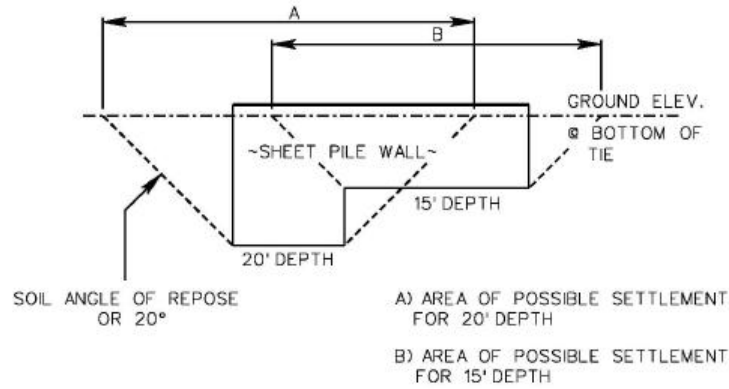


**Figure 3, Plan View of Underground Crossing**

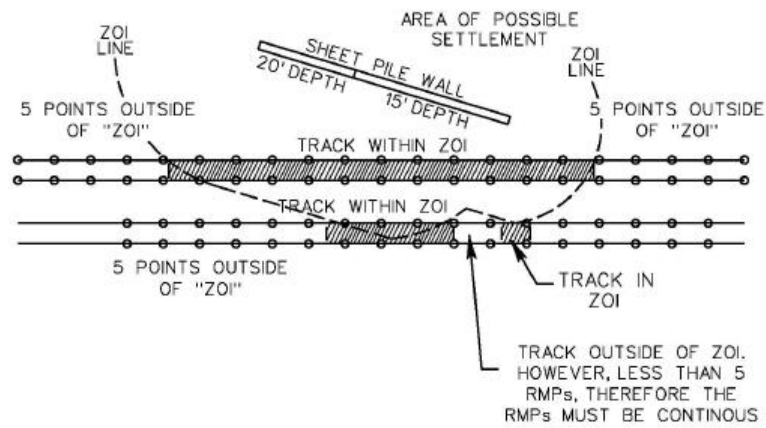


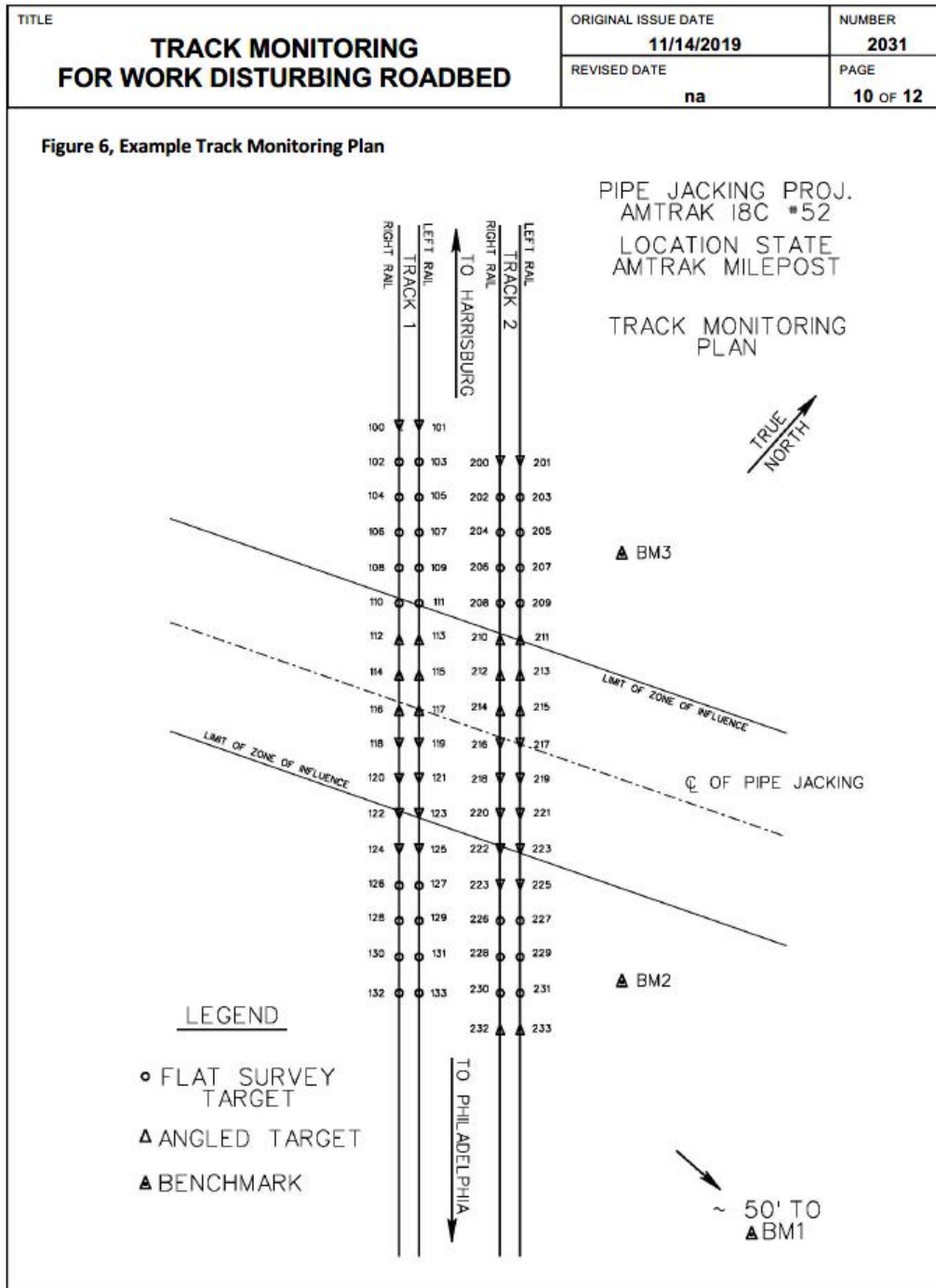
<b>TITLE</b> <b>TRACK MONITORING          FOR WORK DISTURBING ROADBED</b>	<b>ORIGINAL ISSUE DATE</b> <b>11/14/2019</b>	<b>NUMBER</b> <b>2031</b>
	<b>REVISED DATE</b> <b>na</b>	<b>PAGE</b> <b>9 OF 12</b>

**Figure 4, Section View of Parallel Work**



**Figure 5, Plan View of Parallel Work**





<b>TITLE</b> <b>TRACK MONITORING FOR WORK DISTURBING ROADBED</b>				<small>ORIGINAL ISSUE DATE</small> <b>11/14/2019</b>	<small>NUMBER</small> <b>2031</b>
				<small>REVISED DATE</small> <b>na</b>	<small>PAGE</small> <b>11 OF 12</b>

**Figure 7, Example Track Monitoring Report**

Monitoring Location: \_\_\_\_\_

Date & Time: \_\_\_\_\_

Underground Work Complete: \_\_\_\_\_ ft

Track Number for this Sheet: \_\_\_\_\_

Right Rail			Left Rail			Cross Level (inches)
RPM	Top of Rail Movement (inches) (displacement from baseline)		RPM	Top of Rail Movement (inches) (displacement from baseline)		
	North	East		East	Elev	
100			101			
102			103			
104			105			
106			107			
108			109			
110			111			
112			113			
114			115			
116			117			
118			119			
120			121			
122			123			

Land Surveyor signature: \_\_\_\_\_ Seal: \_\_\_\_\_

Track Inspector signature: \_\_\_\_\_

Track Inspector SAP number: \_\_\_\_\_



TITLE <b>TRACK MONITORING                  FOR WORK DISTURBING ROADBED</b>	ORIGINAL ISSUE DATE <b>11/14/2019</b>	NUMBER <b>2031</b>
	REVISED DATE <b>na</b>	PAGE <b>12 OF 12</b>

**Figure 8, Example Zone of Influence (Subsidence) Calculation**

Scenario

Pipe jacking, perpendicular under tracks. 48-inch diameter pipe, 11-feet from top of rail elevation to top of pipe. No soil boring data given, assume Angle of Repose = 20°.

Calculations

Pipe Work ø 48-inch = 4.00 ft

Top of rail to bottom of tie 1.25 ft (typical)

Bottom of tie to center of pipe depth top rail to top pipe – typical track depth + 1/2 Work  
11.00 ft – 1.25 ft + 2.00 ft = 7.75 ft

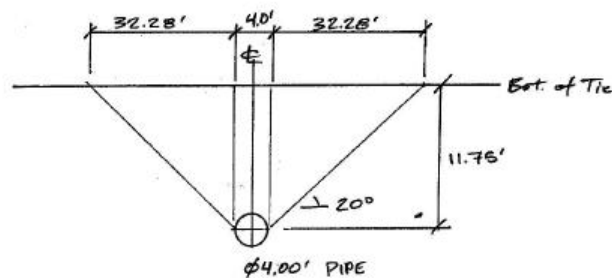
Half width of ZOI [depth \* tan (angle of repose)] + 1/2 Work  
[(11.75 ft) tan (90° - 20°)] + 2.00 ft = 34.28 ft

Convert ZOI to stations 34.28 ft / 15.5 ft = 2.216 (round)-> 2 stations

Determine total RMP pairs on each track

Center station (1) + Stations in ZOI, each direction (2 + 2) + Five tie-in stations (5 + 5) = Total

Total pairs of RMPs = 15 (centered on crossing)



CITY OF ANN ARBOR  
SPECIAL PROVISION  
FOR  
**LIQUIDATED DAMAGES FOR OTHER DEPARTMENT COSTS**

BBT:CED

1 of 2

4/1/24

**a. Description.** The schedule of liquidated damages applies to any situation in which the Contractor fails to open the Michigan Line to railroad traffic as specified herein. The schedule of liquidated damages also applies to any situation in which the Contractor fails to complete required work within the allowable 36-hour maximum railroad closure duration to make the Michigan Line accepted for permanent railroad traffic as determined by the Amtrak representative. The maximum railroad closure duration will not be adjusted for any reason, cause or circumstance whatsoever, regardless of fault, save and except in the instance of a catastrophic event (i.e. natural disaster or a declared state of emergency).

For the Michigan Line, damages will be assessed on a daily basis for each and every one (1) hour interval. The damages will apply for any time on which the Michigan Line closure exceeds the time limitation specified herein. Time assessments will be determined by the Engineer between the begin/end time stated in the specifications and when the Engineer and Amtrak representative determines full compliance with all requirements for safely opening the Michigan Line to permanent railroad traffic. Costs for portions of the full hour intervals will not be prorated and the damages will be cumulative as shown in Tables 1 and 2.

**b. Materials.** None.

**c. Construction.** A railroad outage will be permitted not to exceed 36-hours in continuous duration. Amtrak will require no more than 6 hours of track time total during this track outage. This time includes both the initial shut down period and the reopening of the tracks. The Contractor has the remaining 30-hours of track time for their own operations prior to being assessed liquidated damages as described in Tables 1 and 2.

**Table 1: Liquidated Damages for the First Day Outside Michigan Line Railroad Traffic Acceptance Requirements**

Amount of Time 36-Hour Track Outage	Liquidated Damages	
	Per Period	Cumulative
0-60 Minutes	\$25,000	\$25,000
>60 Minutes up to 2 Hours	\$25,000	\$50,000
>2 Hours up to 3 Hours	\$25,000	\$75,000
>3 Hours up to 4 Hours	\$25,000	\$100,000
>4 Hours up to 5 Hours	\$25,000	\$125,000
>5 Hours up to 6 Hours	\$25,000	\$150,000
>6 Hours up to 7 Hours	\$25,000	\$175,000
>7 Hours up to 8 Hours	\$25,000	\$200,000
>8 Hours up to 9 Hours	\$25,000	\$225,000
>9 Hours up to 10 Hours	\$25,000	\$250,000
>10 Hours up to 11 Hours	\$25,000	\$275,000
>11 Hours up to 12 Hours	\$25,000	\$300,000

>12 Hours up to 13 Hours	\$25,000	\$325,000
>13 Hours up to 14 Hours	\$25,000	\$350,000
>14 Hours up to 15 Hours	\$25,000	\$375,000
>15 Hours up to 16 Hours	\$25,000	\$400,000
>16 Hours up to 17 Hours	\$25,000	\$425,000
>17 Hours up to 18 Hours	\$25,000	\$450,000
>18 Hours up to 19 Hours	\$25,000	\$475,000
>19 Hours up to 20 Hours	\$25,000	\$500,000
>20 Hours up to 21 Hours	\$25,000	\$525,000
>21 Hours up to 22 Hours	\$25,000	\$550,000
>22 Hours up to 23 Hours	\$25,000	\$575,000
>23 Hours up to 24 Hours	\$25,000	\$600,000

**Table 2: Liquidated Damages for the Second or More Days Outside Michigan Line Railroad Traffic Acceptance Requirements**

Amount of Time 36-Hour Track Outage	Liquidated Damages	
	Per Period	Cumulative
0-60 Minutes	\$25,000	\$625,000
>60 Minutes up to 2 Hours	\$25,000	\$650,000
>2 Hours up to 3 Hours	\$25,000	\$675,000
>3 Hours up to 4 Hours	\$25,000	\$700,000
>4 Hours up to 5 Hours	\$25,000	\$725,000
>5 Hours up to 6 Hours	\$25,000	\$750,000
>6 Hours up to 7 Hours	\$25,000	\$775,000
>7 Hours up to 8 Hours	\$25,000	\$800,000
>8 Hours up to 9 Hours	\$25,000	\$825,000
>9 Hours up to 10 Hours	\$25,000	\$850,000
>10 Hours up to 11 Hours	\$25,000	\$875,000
>11 Hours up to 12 Hours	\$25,000	\$900,000
>12 Hours up to 13 Hours	\$25,000	\$925,000
>13 Hours up to 14 Hours	\$25,000	\$950,000
>14 Hours up to 15 Hours	\$25,000	\$975,000
>15 Hours up to 16 Hours	\$25,000	\$1,000,000
>16 Hours up to 17 Hours	\$25,000	\$1,025,000
>17 Hours up to 18 Hours	\$25,000	\$1,050,000
>18 Hours up to 19 Hours	\$25,000	\$1,075,000
>19 Hours up to 20 Hours	\$25,000	\$1,100,000
>20 Hours up to 21 Hours	\$25,000	\$1,125,000
>21 Hours up to 22 Hours	\$25,000	\$1,150,000
>22 Hours up to 23 Hours	\$25,000	\$1,175,000
>23 Hours up to 24 Hours	\$25,000	\$1,200,000

CITY OF ANN ARBOR  
SPECIAL PROVISION  
FOR  
**STONE MASONRY FACADE**

BBT:CED

1 of 6

3/19/24

**a. Description.** This work consists of furnishing all materials, equipment and labor to furnish and install a stone façade, caps, and signs as shown on the plans and as specified herein.

**b. Materials.**

1. Split Field Stone. Provide split field stone products below from the following manufacturer or an approved equal:
  - a. Thin veneer split field stone from the Boulder Collection
  - b. Supplier: Halquist Stone
    - i. [www.halquiststone.com](http://www.halquiststone.com)
    - ii. (262) 246-9000
2. Limestone. Provide limestone products below from the following manufacturer or an approved equal for the block veneer, wall caps, and decorative signs.
  - a. Thin veneer Indiana "Bedford" Buff from the Cut Stone Collection
  - b. Supplier: Halquist Stone
    - i. [www.halquiststone.com](http://www.halquiststone.com)
    - ii. (262) 246-9000
3. Cement Masonry Units (CMU's). Provide 6-inch x 8-inch x 16-inch normal weight hollow concrete masonry block units in accordance with ASTM C 90. Store CMS's on elevated platforms in a dry location. If not in an enclosed location, cover tops and sides of stacks with securely tied waterproof sheeting. Provide units with a minimum compressive strength of 2000 psi.
4. Mortar and Grout.
  - a. Cement. Provide masonry cement material meeting ASTM C91/C91M. Provide mortar cement material meeting ASTM C1329/C1329M.
  - b. Aggregate. Provide aggregate meeting ASTM C144. Use washed aggregate consisting of natural sand or crushed stone for mortar that is exposed to view. Provided aggregate for grout meeting ASTM C404.
  - c. Mortar. Provide mortar consisting of Portland cement meeting ASTM C150, Type I, or Federal Specification SS-C-1292, Type I. Masonry cements must be manufacturer prepared or site prepared to meet or exceed the requirements of ASTM C-270. Provide lime meeting ASTM C207, Type S or ASTM C5 (quicklime). Provide mortar sand meeting ASTM C144, except that for joints ¼-inch or less in thickness, 100% must pass a No. 16 sieve. Provide clean, potable water free from deleterious amounts of acids, alkalis or organic materials.
  - d. Do not use calcium chloride in mortar or grout.
  - e. Add cold-weather admixture (if used) at same rate for all mortar that will be exposed to view, regardless of weather conditions, to ensure that mortar color is consistent.
  - f. Water. Use potable water.
  - g. Grout. Provide grout in accordance with ASTM C-476 with aggregates in

- accordance with ASTM C-404. Mix grout with 1 part Portland cement by volume, 0 to 1/10 part lime or lime putty by volume, fine aggregate (measured in damp, loose condition) 2 ¼ to 3 times the sum of volumes of cementitious materials, coarse aggregate (measured in a damp, loose condition) 1 to 2 times the sum of volumes of cementitious materials, potable water sufficient to obtain 8 to 10 inch slump.
- h. Store masonry cement, Portland cements, and lime on wooden pallets or other material that will not collect condensation and off the ground in a dry condition. Keep sand clean.
  - i. Machine mix mortar materials in a batch, drum-type mixer for not less than 5 minutes. Use of a continuous mortar mixer is acceptable. Measure quantities by the box and do not use shovel measurements. Adjust mix due to climate conditions for best workability. Do not use anti-freeze materials.
  - j. Provide masonry cement according to the manufacturer's recommendations. Field prepared mortar must be proportioned within the limits, by volume, provided below:
    - i. Type M; 1 part Portland cement, ¼ part hydrated lime, not less than 2 ¼ and not more than 3 times the sum of the volumes of cement and lime used.
    - ii. Type S; 1 part Portland cement, ½ part hydrated lime, not less than 2 ¼ and not more than 3 times the sum of the volumes of cement and lime used.
    - iii. Type N; 1 part Portland cement, 1 part hydrated lime, not less than 2 ¼ and not more than 3 times the sum of the volumes of cement and lime used.
    - iv. Non-Staining; 1 part Portland cement, 1 part hydrated lime, 6 parts sand.
  - k. Prehydrate all mortars used for tuck pointing. Thoroughly mix all ingredients except water; then mix again, adding only enough water to produce a damp workable mix which will retain its form when pressed into a ball. After 1 to 2 hours, add sufficient water to bring it to the proper consistency; that is, somewhat drier than conventional masonry mortars.
  - l. Retemper mortars that have stiffened because of evaporation of water from the mortar as frequently as needed to restore the required consistency. Use mortars and place in final position within 2 ½ hours after initial mixing.
  - m. Use the same brands of cementitious materials and source of supply of sand throughout the entire project.
5. Masonry Joint Reinforcement. Install entire length of longitudinal side rods with a minimum cover of 5/8 inch on exterior side of walls and ½ inch elsewhere. Lap reinforcement a minimum of 6 inches Cut and bend reinforcing units as directed by the manufacturer for continuity at corners, returns, offsets, and other special conditions.
  6. Steel Lintel. Provide lintel support for stonework in accordance with Section 707 of the Standard Specifications for Construction. Provide materials meeting the requirements of Section 906 of the Standard Specifications for Construction. Use Gr. 36 steel. Galvanize materials according to subsection 707.03.C.17 of the Standard Specifications for Construction.
  7. Stone Trim Anchors. Fabricate anchors form stainless steel, ASTM A240/A240M or ASTM A666 Type 304. Use annealed stainless steel bolts, nuts, and washers; ASTM F593 for bolts and ASTM F594 for nuts, Alloy Group 1. Use chemical anchors, torque controlled expansion anchors, or undercut anchors made from stainless steel components complying with ASTM F593 and ASTM F594, Alloy Group 1 or 2 for bolts

- and nuts, ASTM 666 or ASTM A276, Type 304 or Type 316, for post-installed anchors.
8. Stone Dowels. Fabricate dowels from stainless steel, ASTM A276, Type 304.
  9. Reinforcing Steel. Provide plain reinforcement steel in accordance with Section 706 of the Standard Specifications for Construction.
  10. Metal Flashing. Provide metal flashing complying with SMACNA's "Architectural Sheet Metal Manual". Use Stainless Steel ASTM A240/A240M or ASTM A666, Type 304 that is 0.016 inches thick. Fabricate continuous flashings in sections 8-feet long minimum, but not exceeding 12-feet. Provide splice plates at joints of formed, smooth metal flashing. Fabricate through-wall flashing with snaplock receiver on exterior face where indicated to receive counterflashing. Fabricate metal drip edges from stainless steel that extend at least 3-inches into the wall and ½-inch out from the wall, with outer edge bend down 30 degrees and hemmed. Soder metal items at corners.
  11. Flexible Flashing. Use rubberized asphalt consisting of a pliable, adhesive rubberized asphalt compound, bonded to a high-density, cross-laminated polyethylene film to produce an overall thickness of not less than 0.030-inches. Use a manufacturer from one of the following, or approved equal:
    - a. Carlisle Coatings & Waterproofing Inc.
    - b. Heckmann Building Products, Inc.
    - c. Hohmann & Barnard, Inc.
    - d. W.R. Meadows, Inc.
    - e. Williams Products, Inc.
    - f. Wire-Bond.
  12. Butyl Rubber Flashing. Use composite, self-adhesive, flashing product consisting of a pliable, butyl rubber compound, bonded to a high-density polyethylene film, aluminum foil, or spunbonded polyolefin to produce an overall thickness of not less than 0.030 inch. Use a manufacturer from one of the following, or approved equal:
    - a. DuPont Safety & Construction.
    - b. GCP Applied Technologies Inc.
    - c. Protecto Wrap Company.
    - d. Raven Industries, Inc.
    - e. Wire-Bond.
  13. EPDM Flashing. Use a sheet flashing product made from ethylene-propylene-diene terpolymer, complying with ASTM D4637/D4637M, 0.040 inch thick. Use a manufacturer from one of the following, or approved equal.
    - a. Carlisle Coatings & Waterproofing Inc.
    - b. Firestone Specialty Products.
    - c. Heckmann Building Products, Inc.
    - d. Hohmann & Barnard, Inc.
    - e. Wire-Bond.

**c. Submittals.** Prepare complete working drawings of all masonry details including split field stone, stone signage, limestone blocks and caps, CMU's, lintels, joint reinforcement, anchors, ties, and flashing. Indicate location and details for lighting conduit and fixtures.

Coordinate adhesive anchor holes in lintel plates with the box culvert manufacturer to avoid conflict with steel reinforcement. Confirm rebar locations in culvert prior to fabricating lintel plates. Use a pachometer to mark reinforcement in culvert if other identifying methods are not used.

**d. Construction.** Take field measurements as necessary to verify or supplement, or both, dimensions indicated in this special provision and on the contract plans.

Clean the exposed surfaces of partially set or totally set fresh masonry and wet it lightly so as to obtain the best possible bond with the new work. Remove all loose stone and mortar.

Remove laitance, loose aggregate and other materials that prevent mortar from bonding to the foundation/concrete wingwall.

Construct all walls and facades plumb and level.

Provide ties in the full bed of mortar at 16-inches vertically and 24-inches horizontally and protect at least 2-inches into the stone veneer and block back-up or concrete back up. Do not place the ties closer than  $\frac{3}{4}$  inch from the exterior face of the stone veneer.

Wet stone surfaces having ASTM C67 absorption rate over 0.025 ounces per square foot per minute. Use wetting method which ensures that each unit is nearly saturated but surface dry when laid. Use warm water in cold weather.

Cut stone units with motor driven saw design to cut with clean sharp, unchipped edges. Cut units as required to provide the stonework that is continuous across bends in the wall and to fit adjoining work neatly. Use full units with cutting wherever possible.

Heat either sand or mixing water to produce mortar temperatures between 40 degrees F and 120 degrees F when working in air temperatures of 40 degrees F to 32 degrees F. Protect masonry from rain for 24-hours by covering with weather-resistant membrane.

Heat sand and mixing water to produce mortar temperatures between 40 degrees F and 120 degrees F when working in air temperatures of 32 degrees F to 25 degrees F. Maintain temperature of mortar on boards above freezing. Completely cover masonry for 24-hours.

Heat sand and mixing water to produce mortar temperatures between 40 degrees F and 120 degrees F when working in air temperatures of 24 degrees F to 20 degrees F. Maintain temperature of mortar on boards above freezing. Completely cover masonry with insulation blankets for 24-hours and provide heat sources on both sides of masonry construction. Provide wind breaks when wind velocity exceeds 15 mph.

Heat sand and mixing water to produce mortar temperatures between 40 degrees F and 120 degrees F when working in air temperatures below 20 degrees F. Maintain minimum temperature of 30 degrees F of masonry units when they are laid. Maintain masonry temperature above 32 degrees F for 24 hours by enclosure and approved heat source, by electric blankets, by infrared lamps, or by other approved methods.

**Mortar Bedding.** Lay solid masonry units with completely filled mortar joints. Do not furrow bed joints. Butter ends of masonry units with sufficient mortar to fill head joints. Rock closures in place with head joints thrown against 2 adjacent masonry units in place. Fill vertical, longitudinal joints by parging either face of backing or back of facing. Do not pound corners and jambs to fit stretcher units after they are set in position. Where an adjustment must be made after mortar as started to harden, remove mortar and replace with fresh mortar.

**Jointing.** Provide a nominal  $\frac{3}{8}$ -inch joint around split field stone and limestone blocks adjusted to unit shape and size. Tool mortar joints in exposed masonry when "thumbprint" hard with round or other approved jointer. Mortar joints must be cut flush in surfaces to be concealed by finished construction.

CMU's. Do not install wet units.

Remove and replace masonry units which are loose, chipped, broken, stained or otherwise damaged, or if units do not match adjoining units as intended. Provide new units to match adjoining units and install in fresh mortar pointed to eliminate evidence of replacement. Perform work at no additional cost to the Department.

Solidly point all voids and holes. Cut out defective mortar joints and point with mortar.

Thoroughly clean face of stone. Remove large mortar particles by hand with wooden paddles and non-metallic scrape hoes or chisels. Test cleaning methods on sample wall panel approximately 10 square feet in area as determined by the Engineer; leave half panel uncleaned for comparison purposes. Obtain Engineer's approval of sample cleaning before proceeding with cleaning of masonry. Protect other surfaces during the cleaning process.

Dry brush exposed masonry at the end of each day's work.

Use of wire brushes, acids, or solutions which might cause discoloration and/or damage to the masonry is expressly prohibited.

Pre-soak or saturate area to be cleaned. Flush the wall with water, from the top down. Starting at the top of wall, apply job-mixed detergent solution by means of the bucket and brush hand-cleaning method. When the use of proprietary masonry cleaning compound is approved by the Engineer, apply compound in compliance with the directions of the compound manufacturer. Rinse wall surfaces thoroughly with clean water after cleaning.

Cover the top of the wall(s) with a strong non-staining waterproof membrane at the end of each day or shut down. Cover partially completed walls when work is not in progress. Extend cover minimum 24-inches down both sides. Hold cover securely in place. When work is resumed, top surface of work must be cleaned of all loose mortar and in drying weather thoroughly wet.

Galvanize and apply the tie coat, intermediate coat, and top coat to the lintel steel material in the shop. Field repair damaged coatings in accordance with subsection 716.03.D.

Use metal flashing where it is indicated to be turned down at or beyond the wall face.

Use metal flashing with a drip edge or flexible flashing with a metal drip edge where flashing is partially exposed and is indicated to terminate at the wall face.

Use flexible flashing where it is fully concealed.

Solder stainless steel flashing using ASTM B32, Grade Sn60 Grade Sn96 with acid flux of type recommended by stainless steel sheet manufacturer.

Use elastomeric sealant conforming to ASTM C920, chemically curing urethane polysulfide silicone sealant; of type, grade, class, and use classifications required to seal joints in sheet metal flashing and remain watertight.

Use adhesives, primers, and seam tape for flashings as recommended by the manufacturer of the flashing for bonding flashing sheets to each other and to substrates.



**e. Measurement and Payment.** The completed work, as described, will be measured and paid for at the contract unit price using the following pay item:

<b>Pay Item</b>	<b>Pay Unit</b>
Split Field Stone .....	Square Foot
Limestone Block.....	Square Foot
Limestone Cap.....	Foot
Limestone Sign, "BANDEMER".....	Each
Limestone Sign, "BARTON".....	Each
Limestone Sign, "2024".....	Each

**Split Field Stone**, includes furnishing all labor, materials and equipment as specified herein and/or as shown on the plans to install the façade and includes CMU's to support it, mortar, properly coated lintel supports, and protection of materials regardless of weather conditions. The quantity will be measured based on the exposed stone surface area. The area of the CMU's below grade is not included in the measurement but is included in the cost of this item.

**Limestone Block** includes furnishing all labor, materials and equipment as specified herein and/or as shown on the plans to install the façade and includes CMU's to support it, mortar, properly coated lintel supports, and protection of materials regardless of weather conditions. The quantity will be measured based on the exposed stone surface area. The area of the CMU's below grade is not included in the measurement but is included in the cost of this item.

**Limestone Cap** includes furnishing all labor, materials and equipment as specified herein and/or as shown on the plans to install the cap and includes mortar and protection of materials regardless of weather conditions. The quantity will be measured based the linear foot installed along the top of the culvert headwall and wingwalls.

**Limestone Sign, \_\_\_** includes furnishing all labor, materials and equipment as specified herein and/or as shown on the plans to install the sign and includes CMU's to support it, mortar, properly coated lintel supports, and protection of materials regardless of weather conditions. The quantity will be measured for each sign installed of the specified type.

## APPENDIX



## GEOTECHNICAL EVALUATION REPORT - REVISED

BARTON-BANDEMER TUNNEL  
CITY OF ANN ARBOR, WASHTENAW COUNTY, MICHIGAN

SME Project Number: 080118.00  
April 12, 2024





The Kramer Building  
43980 Plymouth Oaks Blvd.  
Plymouth, MI 48170-2584

T (734) 454-9900

[www.sme-usa.com](http://www.sme-usa.com)

April 12, 2024

Mr. Jeremy Hedden, PE  
Colliers Engineering & Design  
7050 W. Saginaw Highway, Suite 200  
Lansing, Michigan 48917

Via E-mail: [jhedden@collierseng.com](mailto:jhedden@collierseng.com)

RE: Revised Geotechnical Evaluation Report - Revised  
Barton-Bandemer Tunnel  
City of Ann Arbor, Washtenaw County, Michigan  
SME Project No. 080118.00

Dear Mr. Hedden:

We have completed our geotechnical evaluation for a new segment of pedestrian trail known as the Barton-Bandemer Tunnel in the City of Ann Arbor, Washtenaw County, Michigan. This revised report includes revisions to the submittal issued on March 28, 2024, and is based on comments received from Colliers Engineering & Design on April 11, 2024. Our scope of services for this project included an adjacent portion of the trail located to the west of the planned tunnel segment. This adjacent trail segment is currently being constructed under a different construction contract. This report for the tunnel segment presents the results of our observations and analyses, our geotechnical recommendations based on our observations at the exploratory locations, and our understanding of the proposed construction.

We appreciate the opportunity to assist Colliers with this project. If you have questions or require additional information, please contact us.

Very truly yours,

**SME**

A handwritten signature in blue ink that reads "Scott T. Roosa".

Scott T. Roosa, PE  
Senior Geotechnical Consultant

# TABLE OF CONTENTS

<b>1. INTRODUCTION .....</b>	<b>1</b>
1.1 SITE CONDITIONS.....	1
1.2 PROJECT DESCRIPTION.....	2
<b>2. EVALUATION PROCEDURES.....</b>	<b>5</b>
2.1 FIELD EXPLORATION .....	5
2.2 LABORATORY TESTING .....	6
<b>3. SUBSURFACE CONDITIONS .....</b>	<b>6</b>
3.1 STA. 135+00 TO STA. 140+00 - BORINGS B4 THROUGH B7 .....	6
3.2 STA. 140+00 TO STA. 143+00 - BORINGS B8 AND B9.....	8
3.3 ADDITIONAL GROUNDWATER CONSIDERATIONS .....	8
<b>4. ANALYSIS AND RECOMMENDATIONS .....</b>	<b>8</b>
4.1 GENERAL DISCUSSION .....	8
4.2 SITE AND SUBGRADE PREPARATION.....	9
4.4 ENGINEERED FILL REQUIREMENTS.....	11
4.5 BOX CULVERT (TUNNEL) RECOMMENDATIONS .....	11
4.6 RETAINING WALLS .....	12
4.6.1 MODULAR BLOCK WALL .....	12
4.6.2 PERMANENT SHEET-PILE WALL .....	13
4.7 ADDITIONAL DESIGN AND CONSTRUCTION CONSIDERATIONS .....	14
<b>5. SIGNATURES .....</b>	<b>14</b>

## APPENDIX A

EXPLORATORY LOCATION DIAGRAM (FIGURE NO. 1)

BORING LOG TERMINOLOGY

BORING LOGS (B4 THROUGH B9)

OBSERVATION WELL LOG (WB7)

REPORTS ON UNCONFINED COMPRESSIVE STRENGTH OF COHESIVE SOIL (2)

## APPENDIX B

IMPORTANT INFORMATION ABOUT THIS GEOTECHNICAL-ENGINEERING REPORT

GENERAL COMMENTS

LABORATORY TESTING PROCEDURES

## 1. INTRODUCTION

This report presents the results of SME's geotechnical evaluation for the planned pedestrian trail segment referred to as the Barton-Bandemer Tunnel in the City of Ann Arbor, Washtenaw County, Michigan. Our services were authorized by Colliers Engineering & Design (formerly Bergmann Associates) via a subconsultant agreement dated November 1, 2021, and a subsequent change order dated November 6, 2023. As part of this contract, SME submitted a geotechnical engineering report to Colliers for an adjacent portion of the Barton-Bandemer Trail that was released for construction under a separate contract.

As input into our evaluation, Colliers Engineering & Design (Colliers) provided SME with the following PDF files:

- A progress plan set dated March 18, 2024, and several preliminary plan sets between 2022, and 2023 (all plan sets prepared by Colliers).

### 1.1 SITE CONDITIONS

The project site is located within the northern portion of the City of Ann Arbor in Washtenaw County, Michigan. Image 1 below shows the approximate location of the site west of M-14/US-23 and south of the Huron River.

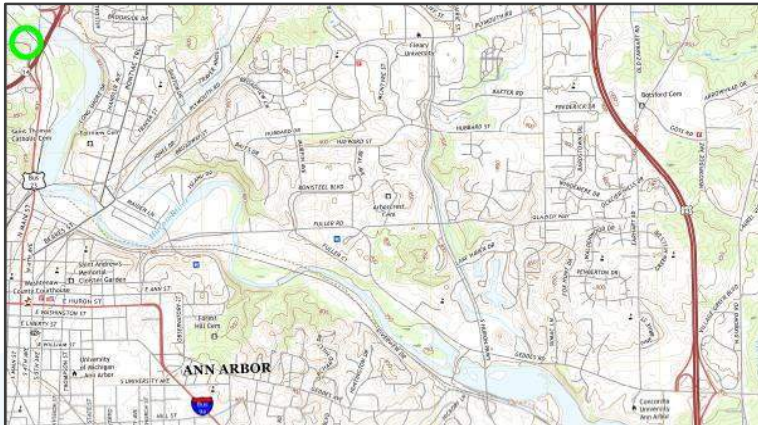


IMAGE 1: USGS map with project area circled in green.



IMAGE 2: Aerial image of project area. Google Earth image dated July 18, 2023.

The aerial image shown in Image 2 depicts the project setting, which is covered with thick vegetation between the Huron River and West Huron River Drive (shown below or south of the river in Image 2). In addition, an Amtrak rail line extends through the project limits.

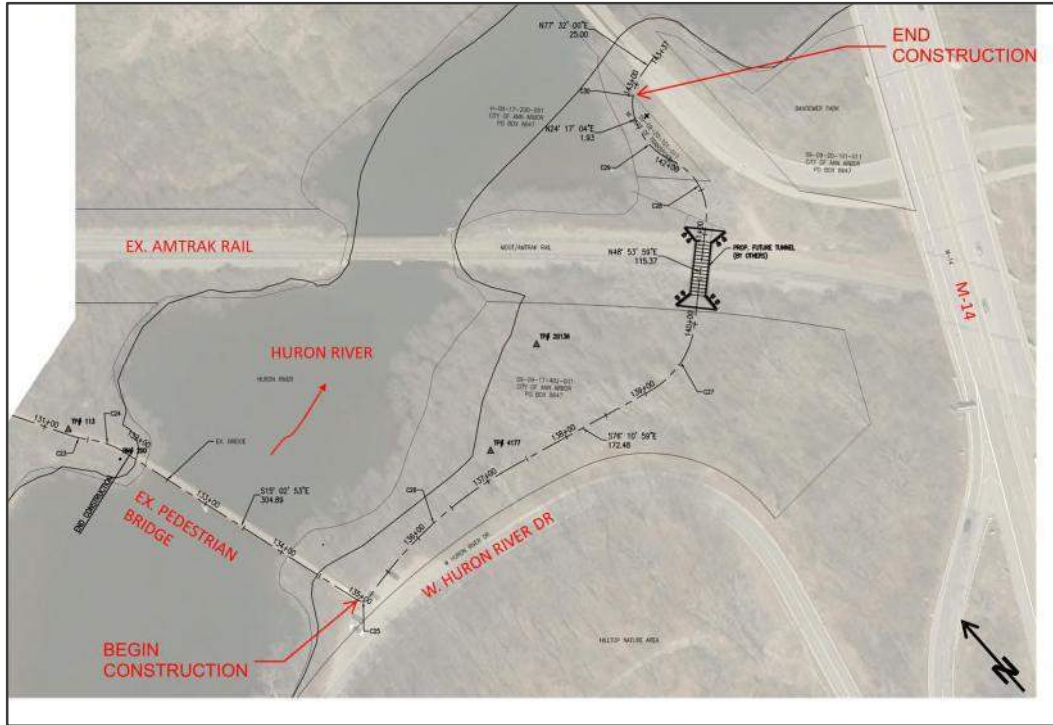
Based on topographic information shown on the referenced plan set, the existing ground surface along the planned trail alignment ranges from about elevation 779 feet in the wooded area north of West Huron River Drive to about elevation 790 feet at the Amtrak rail line. Survey data shown on the plans indicate a recorded Huron River water level at elevation 772.7 feet, and the 100-year flood elevation is shown to be 776.6 feet. Regulated and non-regulated streams and wetland areas are depicted on the plan set between Huron River Drive and the Amtrak rail line.



**IMAGE 3: North of W. Huron River Drive looking north towards the Amtrak rail line in the background and the regulated stream in the foreground. Photograph taken March 9, 2022.**

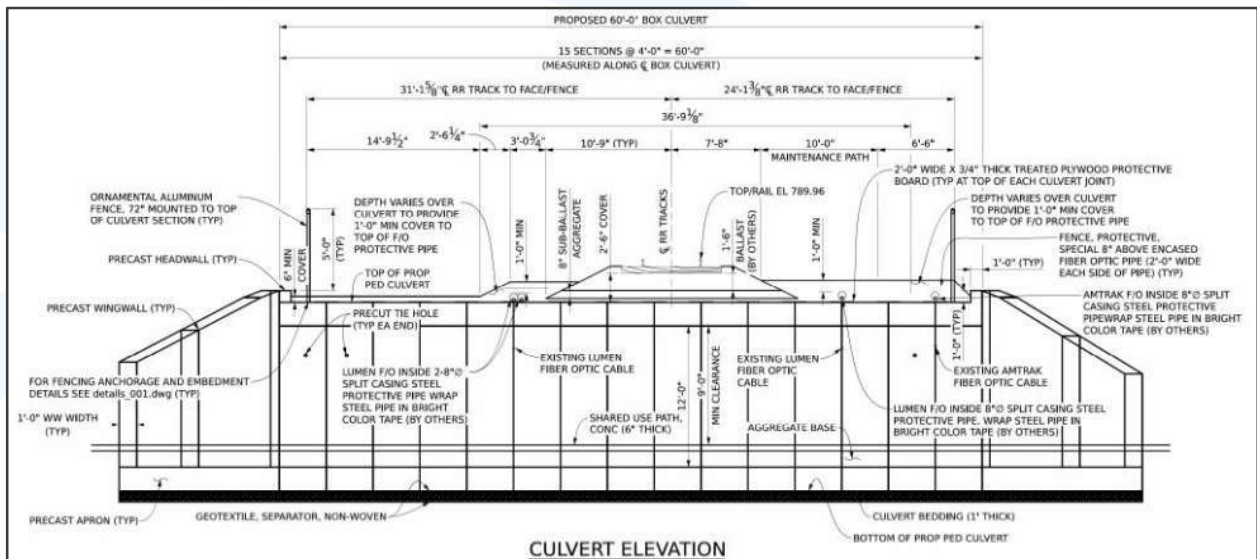
## 1.2 PROJECT DESCRIPTION

Representatives of the City of Ann Arbor and the Washtenaw County Parks Department are planning a segment of trail known as the Barton-Bandemer Tunnel on the north side of Ann Arbor. This segment of trail is planned to begin near Station 135+00 where an existing pedestrian bridge crosses the Huron River on the north side of West Huron River Drive. From the end of the bridge, the proposed trail alignment extends east and north through a wooded area, below the Amtrak rail line, and connects to an existing trail north of the rail. This planned trail segment will end at about Station 143+00.



**IMAGE 4: Proposed trail alignment. Image from the progress plan set (with mark-ups by SME).**

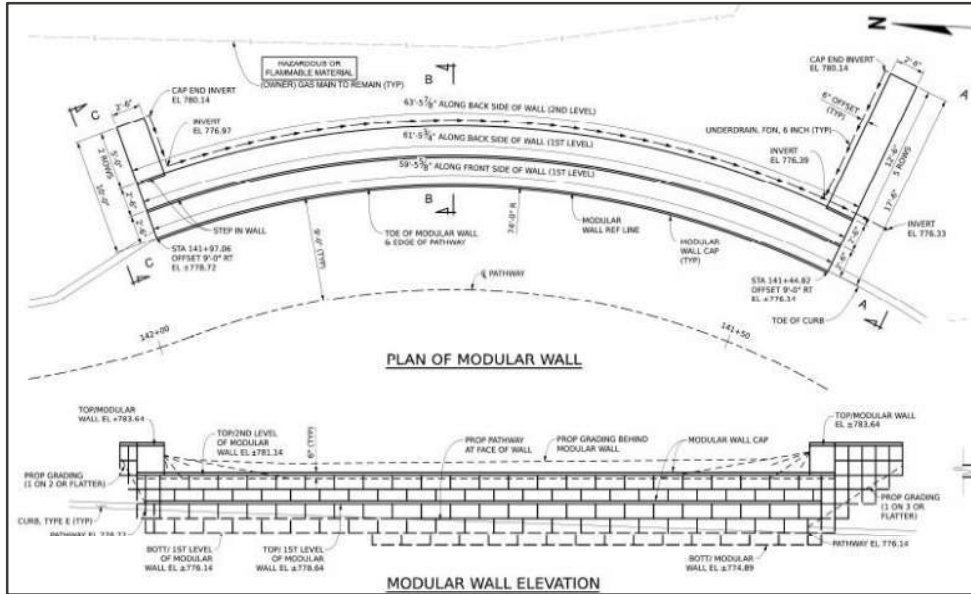
Image 4, above, shows the planned trail alignment. The trail is planned to be conveyed below the Amtrak rail line via a four-sided, 16-foot-wide by 12-foot-tall, precast concrete box culvert – also referred to herein as a tunnel. The bottom of the proposed structure is planned to be set near about elevation 770.3 feet, and wing walls are planned at both ends to accommodate grade transitions. The existing profile grade of the rail at the tunnel crossing is near elevation 790 feet. Construction of the structure is planned to require a temporary rail outage and temporary earth support to facilitate excavations and support of utilities during the planned rail outage.



**IMAGE 5: Planned culvert elevation drawing. Image from the progress plan set.**

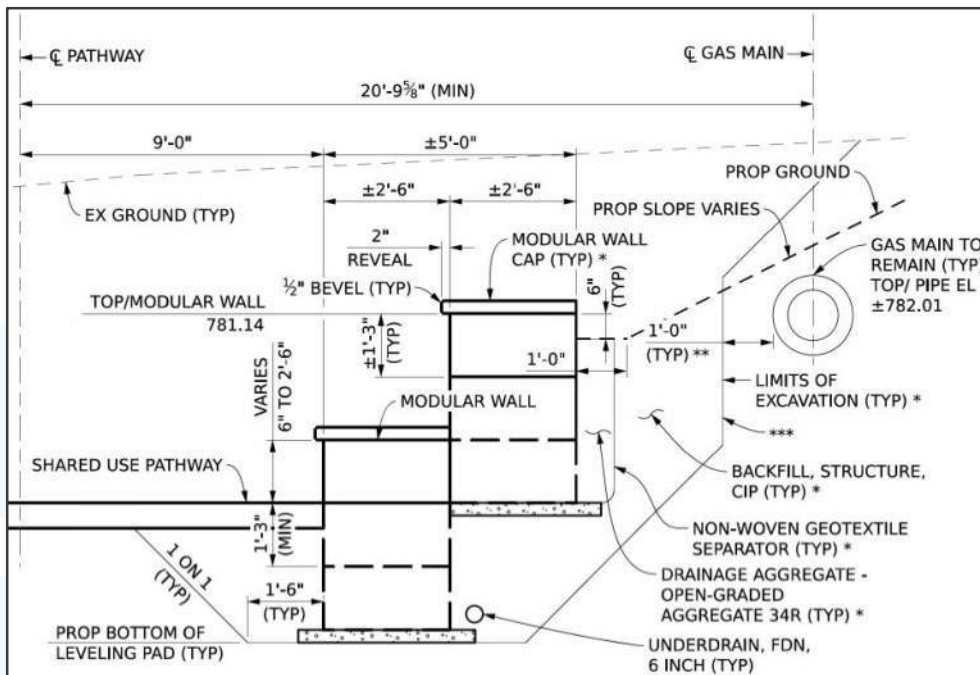
North of the tunnel, permanent grade separation structures are planned to accommodate grades for the tunnel and reduce impacts to adjacent elements. Between about Station 141+50 and Station 142+00, a modular block retaining wall is planned.





**IMAGE 6: Modular Block Wall Plan and Elevation from the progress plan set.**

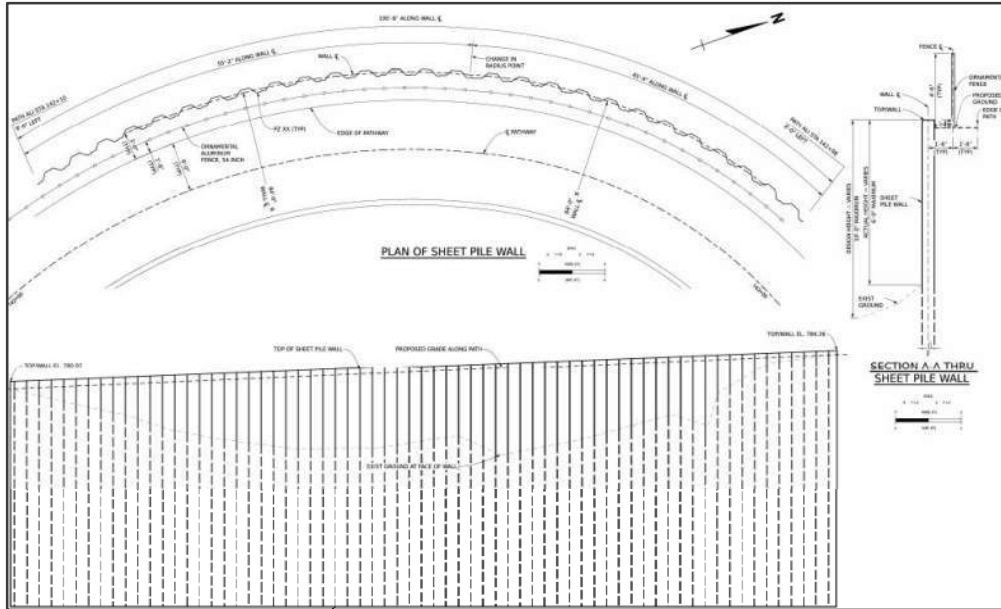
The modular block retaining wall is planned to be “stepped” up and away from the trail alignment, and no reinforcement in the soil backfill is anticipated to be necessary according to the progress plan set.



**IMAGE 7: Image from the progress plan set showing typical section of modular block wall and existing gas line.**

The modular block retaining wall will provide grade separation between the trail and an existing buried gas line located behind the wall. No information is known by SME regarding minimum cover requirements of the gas main or soil conditions at the planned wall relative to the location of the gas main. This wall was added to the project after geotechnical field activities were performed, and no borings were performed by SME with the intent of providing recommendations for design and construction of this wall.

Beginning at about Station 142+10 and continuing to about Station 142+98, a steel sheet-pile wall is planned on the west side of the trail to provide grade separation between the trail and the Huron River. The steel sheet-pile wall is planned to have an exposed height of about 6 feet at the front face of the wall, and a maximum permanent design height of 10 feet (meaning the wall is designed to lose 4 feet of soil in front of the wall due to erosion or scour after the wall is initially built with 6 feet of exposed wall face).



**IMAGE 8: Sheet-pile wall images from the progress plan set.**

Away from the tunnel, earth cut and fill heights are generally less than about 5 feet to 6 feet. Preliminary typical sections indicate slope inclinations are generally planned to be 1 Vertical to 2 Horizontal (1V:2H), or flatter. Drainage improvements are planned to include new shallow storm sewers below the trail, and the existing streams/ditches are planned to be rerouted below the trail. Where the streams/ditches are rerouted below the trail, a new timber pedestrian structure with a span length of about 10 feet is planned near Station 138+00. Details regarding the planned structure were conceptual in nature at the time this report was prepared, and no geotechnical information was obtained at the planned crossing location.

## 2. EVALUATION PROCEDURES

### 2.1 FIELD EXPLORATION

For this portion of the trail, SME performed six borings (designated B4 through B9) at the site between March 21, 2022, and January 19, 2023. Borings designated B1 through B3 and several hand auger borings were performed for the adjacent trail segment (currently under construction) located west of the point of beginning (POB) for this project. The subsurface conditions at those locations were submitted to Colliers under separate cover for the aforementioned trail construction project.

The number, locations, and depths of the borings were determined jointly by Colliers and SME. SME staked the borings in the field using a hand-held GPS unit, and estimated the existing ground surface elevation at each boring location to the nearest 1-foot based on the project topographic information included on the referenced plans.

The borings were performed using a rotary-type drill rig mounted on an ATV using continuous-flight augers. The borings included soil sampling using the Split-Barrel Sampling procedure.

Groundwater observations were recorded during and immediately after completion of each boring. After completion of drilling and recording groundwater observations, the boreholes were backfilled with auger cuttings, with the exception of borings B7, B8, and B9, where cement-bentonite grout was utilized to backfill the boreholes. Additionally, an observation well (WB7) was installed at an offset location of boring B7 to a depth of about 24 feet (or to about elevation 756 feet). A copy of the well log for Well WB7 is included in Appendix A. Groundwater was sampled by an SME staff technician and a water sample was submitted for 1,4-Dioxane testing. The test results were submitted to the project team under separate cover.

Soil samples recovered from the field exploration were delivered to our laboratory for further observation and testing.

## 2.2 LABORATORY TESTING

The laboratory testing program consisted of performing visual soil classification on recovered samples in general accordance with ASTM D2488, and moisture content and shear strength tests on portions of recovered cohesive samples. Moisture content tests were also performed on samples of organic silt obtained from the boring locations. Additionally, unconfined compressive strength tests and Atterberg limit determination testing were performed on representative cohesive soil samples. Results of the laboratory tests are shown either on the boring logs in Appendix A or on the laboratory summary sheets in Appendix A. The Laboratory Testing Procedures in Appendix B provides descriptions of these laboratory tests. Based on the laboratory testing and visual classifications, we assigned a Unified Soil Classification System (USCS) group symbol to the each of the various soil strata encountered.

Upon completion of the laboratory testing, boring logs were prepared and include the soil descriptions, penetration resistances, pertinent field observations, and the results of the laboratory testing. Each boring log includes the estimated latitude, longitude, station (where available) and existing ground surface elevation. The boring logs are included in Appendix A. Explanations of symbols and terms used on the boring logs are provided on the Boring Log Terminology sheet included in Appendix A.

The Standard Penetration Test (SPT) resistances (N-values) plotted on the boring logs represent a modified N-value based on the correlation between the recorded SPT value and the measured hammer efficiency of the testing equipment (also shown on the boring log). Specifically, the plotted N-values have been normalized to a 60 percent hammer efficiency ( $N_{60}$ ).

## 3. SUBSURFACE CONDITIONS

### 3.1 STA. 135+00 TO STA. 140+00 - BORINGS B4 THROUGH B7

Borings B4 through B7 were performed in or near the wooded area between the existing pedestrian bridge and the planned rail crossing, between about Station 135+00 and Station 140+00. No discernible topsoil layer was reported at boring B4, which was performed nearer an existing gravel parking area at the south end of the pedestrian bridge and on the north side of W. Huron River Drive. At borings B5 and B6, about 13 inches to 15 inches of topsoil was reported by the drilling team. The near-surface soils at boring B7 were described as clayey sand with occasional sandy organic layers to a depth of 3 feet. The ground surface at boring B4 was near elevation 788 feet, whereas the ground surface at borings B5 through B7 was between about elevations 780 feet and 782 feet. The following subsurface discussion is focused on observations at borings B5 through B7 as the conditions relate to constructability of the trail and tunnel. The conditions at boring B4 are not discussed further below since this boring was performed on higher ground (at about elevation 788 feet).

Below the surficial soils, granular-type soils were observed at borings B5 through B7 to depths ranging from about 3 feet to 8 feet, or to about elevation 774 feet to elevation 777 feet, below the existing ground surface and were underlain by cohesive-type soils described as lean clay and silty clay. Groundwater was perched in the granular soil strata at depths ranging from about 2½ feet to 5½ feet below the existing

ground surface at these three boring locations. Additionally, a stratum of organic silt (also called “marl”) and a stratum of clayey sand with occasional shell fragments were observed at boring B6 at depths ranging from about 3½ feet to 8 feet, or between about elevation 774 feet and elevation 778.5 feet, below the existing ground surface. The moisture content of the organic silt was 42 percent. Below the sands, the consistency of the cohesive soils was described as stiff to hard based on hand penetrometer type undrained shear strength estimates ranging from 1½ to more than 4½ kips per square-foot (ksf). The moisture contents were typically in the range of about 11 to 17 percent. Exceptions to this were observed at boring B7, where soft to very soft cohesive-type soils were observed about 3 feet to 7 feet, or to about elevation 773 feet to elevation 777 feet, below the existing ground surface. Undrained shear strength estimates of less than ½ ksf and moisture contents ranging from 22 to 26 percent were observed in this stratum.

The cohesive soils were observed to extend to about 22 feet to 27½ feet below the existing ground surface at borings B5 through B7, or to about elevation 753.5 feet to 758 feet. The cohesive soils were underlain by granular-type soils (silty sand and clayey sand) extending to the maximum depths explored. At boring B7, a borehole heave in the annulus of the augers was observed during drilling activities at a depth of 22 feet, or about elevation 758 feet, which is indicative of an artesian condition. SME abandoned the borehole and backfilled with cement-bentonite grout, then offset to resume sampling at a depth of 23½ feet. At the offset location, the annulus of the augers was filled with water and bentonite slurry to counteract the hydrostatic pressure in the granular soil layer observed with depth. The relative density of the granular soils was described as dense to extremely dense based on N-values ranging from 36 to 71 blows per foot of penetration (bpf) and penetration resistances ranging from 71 to 87 blows per 6 inches.

SME installed a temporary piezometer (referred to herein as an observation well) at a depth of 24 feet, tip near elevation 756 feet, at an offset location of boring B7. The observation well (referred to as WB7) consisted of PVC casing that was slotted in the lower 10 feet to measure the hydrostatic head level in the lower sand stratum. After installation of the observation well on March 21, 2022, the water level in the pipe was observed to be below the existing ground surface. An SME technician returned to the site on March 31, 2022, to record the water level and obtain a water sample for laboratory testing at the request of Colliers. SME observed water to be flowing out of the top of the PVC casing, suggesting the hydrostatic head level was above the existing ground surface and the top of the PVC casing. SME returned to the site on April 1, 2022, and added a section of PVC casing to the top of the installed pipe to permit the water to rise and stay within the extended PVC casing. The water level reading was observed to be about 3.2 feet above the ground surface, or about elevation 783.2 feet. SME remobilized to abandon the well by tremie-placing cement-bentonite grout on April 8, 2022.



**IMAGE 9: Photo of temporary observation well with additional casing. Photo taken April 1, 2022.**

### 3.2 STA. 140+00 TO STA. 143+00 - BORINGS B8 AND B9

Borings B8 and B9 were performed north of the Amtrak rail line. Boring B8 was performed near the existing rail line. The subsurface conditions at boring B8 consisted of about 24 inches of sandy topsoil underlain by granular fill soils extending to a depth of about 11½ feet, or to about elevation 775.5 feet, below the existing ground surface. The granular fill soils contained cinders and brick fragments. Below the fills, naturally occurring cohesive-type soils extended to a depth of about 29 feet, or to about elevation 758 feet, below the existing ground surface. The consistency of the cohesive-type soils was described as very stiff to hard based on hand penetrometer undrained shear strength estimates ranging from 3½ to more than 4½ ksf. Moisture contents in the cohesive soils were in the range of 10 to 15 percent. Results of an unconfined compressive strength test performed on a disturbed split-barrel sample obtained near a depth of 14 feet indicated an undrained shear strength of 2.93 ksf. Below the cohesive soil strata in boring B8, both granular and cohesive-type soils were observed extending to the explored depth of about 59 feet. The relative density of the granular soil strata was described as dense to extremely dense. Groundwater was initially observed at a depth of 8½ feet, or at about elevation 778.5 feet, during drilling activities. The annulus of the hollow-stem augers was charged with water during drilling activities at the location of boring B8 at a depth of about 15 feet, and no borehole heave was noted during drilling activities.

Boring B9 was performed north of the wooded area located north of the rail line and south of the existing pedestrian trail, and in the vicinity of the proposed sheet pile wall. Below about 17 inches of surficial topsoil, clayey fill soils were observed to a depth of about 13½ feet, or to about elevation 770.5 feet, below the existing ground surface. Results of hand penetrometer type undrained shear strength estimates on the clay fill were in the range of 2 ksf to more than 4½ ksf, and moisture contents ranged from 13 to 17 percent. Below the fill soils, a stratum of clayey sand and stratum of organic silt were observed extending to a depth of about 17½ feet below the existing ground surface, and were underlain by granular soils to a depth of about 22 feet (elevation 762 feet). Below the granular soils, strata of cohesive-type soils and cohesionless silt were observed extending to a depth of about 49 feet. Undrained shear strength estimates on the cohesive soils were observed to be 4½ ksf or greater, and moisture contents ranged from 14 to 22 percent. Gravel with cobbles was encountered below 49 feet and extending to the explored depth of 52 feet. N-values below about elevation 754 feet exceeded 50 bpf. Results of Atterberg limit determinations indicated plasticity indices (PI) of 7 and 9 in the naturally occurring cohesive soils and the fill, respectively.

### 3.3 ADDITIONAL GROUNDWATER CONSIDERATIONS

A summary of our observations at the exploratory locations is discussed above and is shown on the boring logs and well log diagram included in Appendix A. Hydrostatic groundwater levels, perched groundwater conditions, and the potential rate of infiltration into excavations should be expected to fluctuate throughout the year, based on variations in precipitation, evaporation, run-off, the water level of the river, and other factors. The groundwater levels indicated by the borings represent conditions at the time the readings were taken. The groundwater levels at the time of construction and in the future may vary from those conditions noted on the logs.

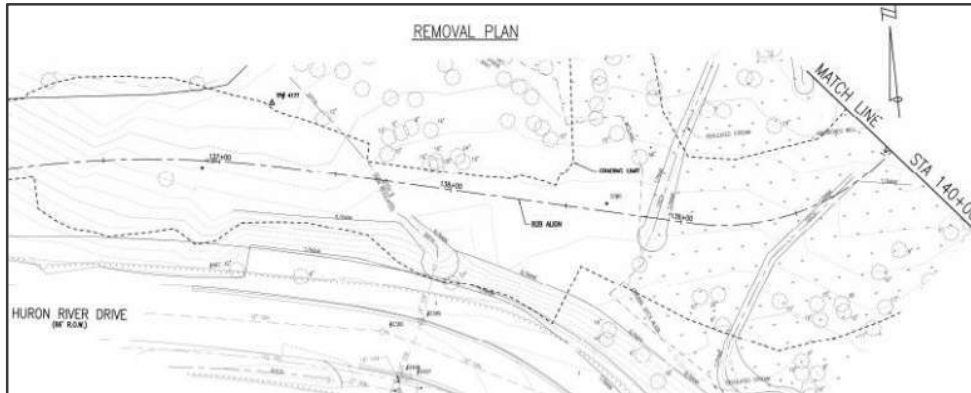
Based on plans provided by Colliers, the water level of the river surveyed in 2023 was elevation 772.7 feet. The 100-year flood level is shown on the plans to be elevation 776.6 feet.

## 4. ANALYSIS AND RECOMMENDATIONS

### 4.1 GENERAL DISCUSSION

The trail begins at the west end of the alignment at an existing pedestrian bridge crossing the Huron River just north of West Huron River Drive. The trail alignment extends north and east of the roadway and through the woods towards the Amtrak rail line. As shown in Image 10 below, an existing non-regulated ditch crosses the planned trail alignment near Station 137+70 and regulated streams/ditches cross the

trail alignment near Station 138+90 and Station 139+60. The area from about Station 138+80 to the west side of the planned tunnel near Station 140+30 is delineated as a wetland area, and there is an existing ditch located along the south side of the rail embankment. The existing ground surface in the wetland area is between about elevation 780 feet and elevation 782 feet. Beginning at about Station 138+00, the grading plan transitions from near the existing ground surface at elevation 782 feet to earth cut, with the planned trail grade lowering to elevation 774 feet in the tunnel below the rail line. The bottom of the box structure is planned to be established near elevation 770.3 feet. The Huron River is shown to be near elevation 773 feet, and the 100-year flood elevation is shown on the plans to be elevation 776.6 feet.



**IMAGE 10: Existing drainage features from the progress plan set.**

Short- and long-term drainage challenges exist for this planned trail project based on the conditions encountered in the borings, on the proposed trail elevations, and on the water levels in the adjacent river. Establishing positive surface drainage, redirecting flows away from the planned trail alignment, and installing temporary underdrains will be critical in performing earthwork activities for construction of the trail. Even after redirecting flows, the bottom of the trail pavement subbase is anticipated to be near the river level at the low point of the trail (i.e., in the tunnel below the rail line). If subsurface drains and positive drainage by gravity cannot be maintained, it may be necessary for a pump system to remove water from low points in the trail.

Additional design and construction recommendations regarding subgrade improvement, construction of the box culvert, modular block retaining wall, and sheet-pile retaining wall are included in the following sections.

## 4.2 SITE AND SUBGRADE PREPARATION

As an initial step in preparing the site, we recommend that the planned drainage improvements consisting of redirecting flows (surface water and groundwater) away from the trail alignment be performed. It will be important to intercept water from below the planned trail grade to be effective in preparing future subgrades. Temporary underdrains may be required to facilitate subgrade preparation. After drainage improvements are performed, we recommend that trees, tree roots, brush, surface vegetation, and existing topsoil and soils containing organic matter be removed from the existing ground surface within the trail footprint and planned earthwork areas, including areas to receive engineered fill. To limit subgrade disturbance, we recommend that removal of the surface materials only occur in those areas where earthwork and embankment/trail construction is planned to follow. Care should be taken to limit subgrade exposure. Positive surface drainage should be established and maintained, and water should not be permitted to pond or accumulate on prepared subgrades. We recommend that the subgrade be regraded and compacted after all stumps and root masses are removed from within the proposed trail and embankment areas. After removal of surficial materials and cutting to the planned subgrade (where necessary), both cohesive- and granular-type soils are anticipated to be exposed throughout the alignment. Although described as granular, the silty sands and clayey sands observed at the boring locations contained an appreciable amount of fine-grained soil particles. These soils are considered moisture-sensitive and are anticipated to behave similarly to cohesive-type soils. Treatment of the subgrade via aeration and recompaction should be anticipated. Based on the groundwater levels

observed at the boring locations, this is anticipated to require favorable weather and site preparation with regard to drainage. Based on the preliminary grading information and our observations at the location of boring B6, organic silt may be exposed at the planned subgrade in the vicinity of Station 138+70. Where these conditions are exposed, undercutting of organic soils and replacement with MDOT Class II sand is recommended.

Between about Station 138+00 to Station 142+00, earth cut is required to achieve the planned subgrade elevations for the proposed trail pavement section and box structure. As mentioned, the area between about Station 138+80 and Station 140+30 is depicted as a wetland area on the plans, and the existing ground surface is typically between elevations 780 feet and 782 feet. About 2 feet to 7 feet of earth cut is planned in this area to achieve the proposed grades. The top of the clay stratum was observed to be between elevations 775 feet and 777 feet. Water is anticipated to be perched in the granular soil strata above this clay stratum and will be encountered during excavation activities to establish the planned subgrade. We recommend that, if feasible, consideration be given to constructing collection trenches/ditches on both sides of the trail alignment that intercept any surface drainage and directs water away from the planned trail subgrade and towards the rerouted streams/ditches.

In general, we recommend the existing subgrade, after stripping and removal of topsoil and vegetation, as described above, and prepared as discussed herein, be compacted to a minimum of 95 percent of the maximum dry density as determined in accordance with the Modified Proctor test. Where the existing subgrade cannot be compacted or where soft conditions are encountered, additional improvement, such as undercutting and replacing with coarse crushed aggregates, possibly in conjunction with biaxial geogrid, may be necessary.

The sheet-pile wall between Station 142+10 and Station 142+98 is planned to be constructed along the existing riverbank, and fill will be required to establish grade for the trail behind the wall. We recommend that, after removal of surficial vegetation and soils containing organic matter, the resulting subgrade behind the wall be evaluated by an SME engineering technician prior to constructing fills. Any soft soils that will not readily compact should be removed and replaced with MDOT Class II sand. If the bottom of the excavation behind the sheet-piling cannot be adequately compacted, it may be necessary to utilize larger open-graded (1-inch by 3-inch) stone wrapped in geotextile as backfill at the excavation base until a stable bottom is obtained for placement of overlying sand fill.

We understand the trail is being designed for support of emergency passenger vehicles and anticipate that the heaviest loading on the subgrade will consist of that required to construct the pavement (i.e., paving equipment). We recommend that construction equipment not be permitted to travel on any prepared subgrades more than that necessary to construct the trail. An otherwise stiff or sound subgrade can quickly become disturbed due to repeated construction traffic. The contractor will need to exercise care when trafficking the subgrade. The type of earthwork equipment used for this project should be limited to lightweight, tracked earthmoving equipment that is specifically suited to traversing weak subgrades.

It may be necessary to limit the size of the compaction equipment used if the applied compaction energy disturbs the subgrade due to the presence of shallow groundwater or poor support conditions. Therefore, in portions of the trail alignment, it may not be feasible to achieve the specified density requirement. Operating vibratory compaction equipment to compact granular soils just above the groundwater could cause "quick" conditions that would necessitate turning the vibratory action off and using static methods for compaction. At a minimum, when placing engineered fill and aggregate base materials close to subgrades containing groundwater, the contractor should be prepared to static roll these materials into place until the subgrade is stable enough to turn on vibratory action. We recommend placing the aggregate base course for pavements shortly after compacting and preparing the subgrade to protect the subgrade and minimize disturbance.

If areas of disturbed subgrade are encountered due to shallow groundwater or unsuitable soils, such areas should be evaluated by SME on a case-by-case basis, and may require improvement through a combination of limited undercutting of unstable materials, and placement of geogrid reinforcement and crushed aggregates. A larger, well-graded coarse crushed aggregate, ranging in nominal size from about 1 inch to 3 inches, may be necessary to improve unstable wet subgrades, as discussed above.

Positive drainage of surface runoff away from the trail surface will also mitigate the potential for premature pavement distress. Grades need to be set for subsurface water to drain out from the aggregate base and away from the trail section. The proposed side-slopes shown in the progress plan set need to be established at 1V:2H or flatter. In general, 1V:2H cut slopes are marginally stable without seepage issues, and establishing vegetation as soon as is practical is critical to performance of the slopes. In cut slopes where drainage cannot be controlled, establishing vegetation may be difficult and it may be necessary to protect the slope from seepage issues by placing riprap over non-woven geotextiles.

#### 4.4 ENGINEERED FILL REQUIREMENTS

We recommend that any fill be spread in level layers not exceeding 9 inches in loose thickness and be compacted to a minimum of 95 percent of the maximum dry density as determined in accordance with the Modified Proctor test. Sand fill should be compacted with a smooth drum vibratory roller or vibratory plate compactors including either walk-behind types, or plate compactors mounted on a backhoe or excavator (hoe-pac). Given the planned earthwork and site conditions, we do not recommend the use cohesive soils for construction of new embankments.

Coarse crushed aggregate used to backfill undercuts or to stabilize subgrades should consist of a crushed natural aggregate or crushed concrete ranging from 1 inch to 3 inches in nominal size with no more than 7 percent by weight passing the No. 200 sieve. In cases where granular engineered fill will be placed over the crushed aggregate, the surface of the coarse crushed material should be choked with a layer of at least 6 inches of dense-graded aggregate, such as MDOT 21AA, or covered with a suitable non-woven geotextile fabric, to mitigate the potential for migration of the granular materials into the coarser crushed aggregate.

#### 4.5 BOX CULVERT (TUNNEL) RECOMMENDATIONS

The bottom of the new four-sided precast concrete structure is planned to be established near elevation 770.3 feet. Based on our observations at the location of borings B7 and B8, the culvert and associated wing wall foundation subgrade is anticipated to consist of stiff to hard cohesive soils. The stiff to hard cohesive soils reported below the planned structure subgrade are anticipated to provide suitable support for the structure and wing walls.

We anticipate that the wing walls will be somewhat free to rotate at the top such that active earth pressures will develop. Foundation excavations and structure backfilling should be performed in accordance with Section 206 of the MDOT Standard Specifications. Table 1 summarizes geotechnical parameters recommended for structure backfill and the foundation subgrade soils for use by the wall designer. Design parameters are based on our observations at the exploratory locations and information in the AASHTO LRFD Bridge Design Manual.



**TABLE 1: SUMMARY OF GEOTECHNICAL PARAMETERS FOR WING WALL DESIGN**

	FOUNDATION SUBGRADE SOILS	STRUCTURE BACKFILL
Internal Friction Angle ( $\phi'$ ; degrees)	---	32
Nominal Cohesion of Foundation Soil (psf)	2,000	---
Sliding Resistance Factor for CIP or Precast Concrete on Clay ( $\phi_s$ )	0.85	---
Friction Angle between Concrete Wall and Structure Backfill ( $\delta$ ; degrees)	---	20
Structure Backfill Moist Unit Weight ( $\gamma$ ; pcf)	---	120
Factored Bearing Resistance (psf)	4,500	---

We anticipate the MDOT-typical minimum bedding system for the box culvert will be suitable for structure support. The structure should be placed over a minimum of 12 inches of bedding material consisting of 9 inches of coarse aggregate 6A, containing at least 80 percent crushed material, covered with 3 inches of aggregate 34R in accordance with Section 406.03.G.2 of the MDOT Standard Specifications for Construction. The exposed subgrade should be probed and tested for suitability of support before placement of the aggregate bedding for the box structure, and unsuitable areas should be undercut and replaced with the 6A coarse aggregate. With the bottom of the bedding layer established near elevation 669.3 feet, the subgrade is anticipated to consist of stiff to hard cohesive soils based on the conditions encountered at borings B7 and B8. It should be noted that, although described as stiff to hard, these soils are moisture-sensitive and will quickly soften if exposed to water. Care should be taken not to permit water and construction activities to disturb the exposed clay subgrade. We recommend that disturbed subgrades or soft cohesive soils be undercut and replaced with additional crushed aggregate.

The bottom of the new structure is planned to be established about 16 feet to 19 feet below the existing profile grade of the rail. Based on the planned construction sequencing and limited track outage period, temporary support is necessary for support of earth parallel to the rail. Due to the hydraulically charged granular soil layer below the confining cohesive soils, we recommend that temporary sheeting adjacent to the rail not extend below elevation 760 feet. Sheeting should be monitored during and after driving to verify that a preferential pathway is not created along the sheets that would permit water to follow the sheet up from the lower granular soil layer. The external stability of the excavation support system should be evaluated for the planned construction sequencing with the design rail surcharge. With the maximum embedment depth recommended of the proposed sheets (i.e., sheeting must not extend below elevation 760 feet), additional passive support systems (e.g., external bracing with thrust blocks) may be necessary to provide lateral support for the sheeting. As an alternative, consideration could also be given to reducing the excavation depths adjacent to the temporary support system while rail traffic is maintained.

## 4.6 RETAINING WALLS

### 4.6.1 MODULAR BLOCK WALL

Preliminary plans indicate a stepped modular block retaining wall is planned on the east side of the alignment between about Station 141+50 and Station 142+00. This wall was added to the project after SME performed exploratory activities and no subsurface information was collected with the intent to provide design and construction recommendations for the wall. As a result, the discussion herein is conceptual based on information shown on the progress plan set. Images 11 and 12 below summarize preliminary plans for the proposed wall. As shown in Image 12, the wall is intended to provide grade separation for the gas main, and care shall be taken to maintain the minimum offset and overburden (cover) specified by the design team. From a design and performance perspective, we recommend that consideration be given to placing an underdrain at the lowest level of the modular block and adjacent pathway as shown in Image 12.

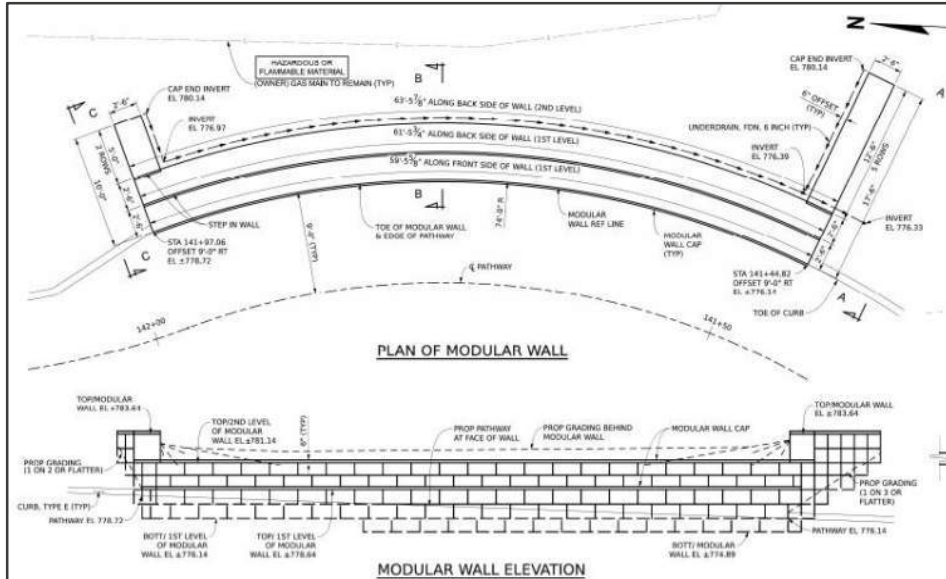


IMAGE 11: Modular block wall plan and elevation from the progress plan set.

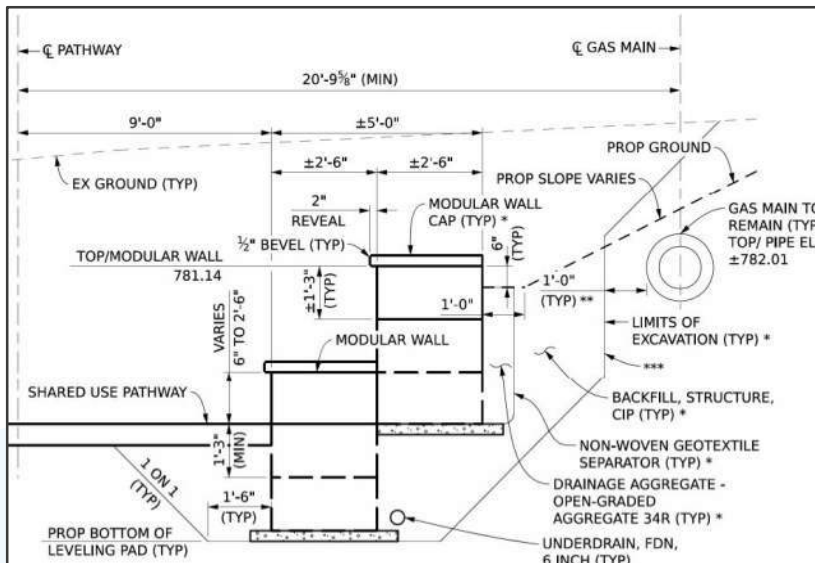


IMAGE 12: Typical section showing modular block wall and trail relative to existing utility.

#### 4.6.2 PERMANENT SHEET-PILE WALL

Based on information shown on the plans, a permanent sheet-pile retaining wall is planned along the river between about Station 142+10 and Station 142+98. The wall is anticipated to have an exposed height of about 6 feet and a maximum design height of 10 feet. Earthwork to raise grades behind the wall will be necessary to construct the wall. After the subgrade is prepared, as discussed in Section 4.2, we recommend that any backfill used to construct the wall consist of MDOT Class II sand compacted in accordance with the recommendations included herein. Based on our observations at the boring locations and our understanding of the proposed construction, we recommend a minimum section modulus of 35 cubic inches (e.g., minimum steel sheet pile PZC-19 or equivalent) with a minimum tip at elevation 753 feet. Based on information shown on the plans, the 100-year flood elevation is shown to be at elevation 776.7 feet. We recommend that regularly spaced, e.g., minimum 10 feet on-center, screened weep holes be constructed through the wall face to reduce the risk of hydrostatic pressures developing on the backside of the wall.

## 4.7 ADDITIONAL DESIGN AND CONSTRUCTION CONSIDERATIONS

Control of groundwater and establishing positive drainage is critical to the long-term performance of the project and success during design. The limited closure duration for the planned track outage to construct the culvert will require that the temporary earth support of the track be in place, and excavations adjacent to the track be made with active groundwater management underway prior to the closure. The design team is developing the design for the temporary earth retention plan. As previously mentioned, we recommend that sheeting not be driven below elevation 760 feet to reduce the risk of penetration into the hydraulically charged sands observed below about elevation 758 feet at the location of boring B7. If the sheets extend through the overlying clay confining stratum and penetrate the underlying sands, we expect that groundwater under artesian conditions will seep upward along the sheets and emanate as seepage at the ground surface. This is a risk that will need to be observed during construction. If conditions vary from those observed at the boring location or if sheets inadvertently penetrate into the hydraulically charged sand layer during construction and seepage is encountered, it may be necessary to engage a specialty contractor to perform grouting to seal the seepage pathway. This risk could be further mitigated by reducing the sheetpile penetration into the clay layer (e.g., increasing the tip elevation to 763 feet for 5 feet) to increase the distance between the sheet pile tip and the sand layer.

The contractor must provide a safely sloped excavation or an adequately constructed and braced shoring system in accordance with federal, state, and local safety regulations for individuals working in an excavation that may expose them to the danger of moving ground. Additionally, if material is stored or equipment is operated near an excavation, stronger shoring must be used to resist the extra pressure due to the superimposed loads. The contractor must protect adjacent existing utilities, rail, and roadways during construction of the proposed trail.

The handling, transportation, and disposal of excavated soil materials should be performed per applicable regulations.

## 5. SIGNATURES

PREPARED BY:



Scott T. Roosa, PE  
Senior Geotechnical Consultant

REVIEWED BY:



Jeffery M. Krusinga, PE, GE  
Chief Geotechnical Consultant

## **APPENDIX A**

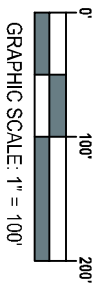
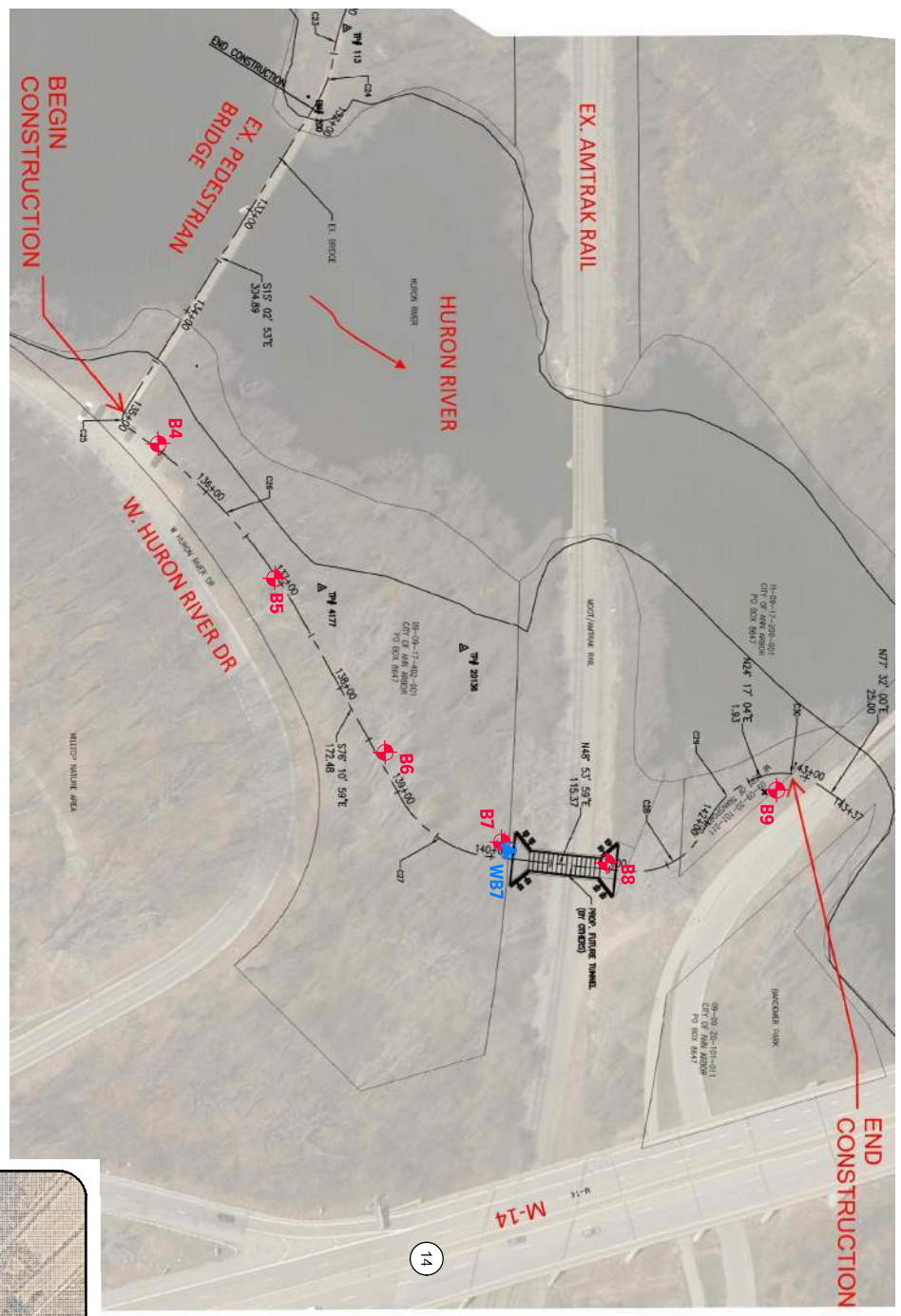
**EXPLORATORY LOCATION DIAGRAM (FIGURE NO. 1)**

**BORING LOG TERMINOLOGY**

**BORING LOGS (B4 THROUGH B9)**

**OBSERVATION WELL LOG (WB7)**

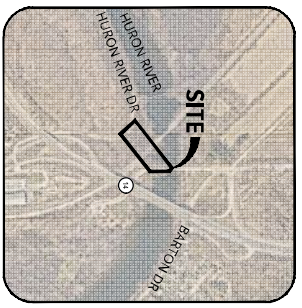
**REPORTS ON UNCONFINED COMPRESSIVE STRENGTH OF COHESIVE SOIL (2)**



- NOTES:
1. AERIAL IMAGE TAKEN FROM GOOGLE EARTH PRO WITH AN IMAGE DATE OF 04-07-2023.
  2. BASE DRAWING INFORMATION PROVIDED FROM A PDF/DRAWING TITLED "PLAN IMAGE", PREPARED BY COLLIER ENGINEERING & DESIGN, UNDATED.

**LEGEND**

- APPROXIMATE BORING LOCATION
- APPROXIMATE LOCATION TEMPORARY OBSERVATION WELL



Project  
**BARTON-BANDEMER TUNNEL**

Project Location  
**CITY OF ANN ARBOR, WASHTEENAW COUNTY, MICHIGAN**

Sheet Name  
**EXPLORATORY LOCATION DIAGRAM**

No.	Revision Date
Date	03-27-2024
CADD	CRC
Designer	STR
Scale	AS NOTED
Project	080118.00
Figure No.	1

DRAWING NOT TO SCALE. OBJECTS IS QUANTIFIED BY AREA, LENGTH AND VOLUME. SCALE DOES NOT APPLY TO DIMENSIONS. DIMENSIONS SHALL BE MADE WITHOUT THE SCALE. © 2022 SME



# BORING LOG TERMINOLOGY

UNIFIED SOIL CLASSIFICATION AND SYMBOL CHART		
<b>COARSE-GRAINED SOIL</b> (more than 50% of material is larger than No. 200 sieve size.)		
Clean Gravel (Less than 5% fines)		
	GW	Well-graded gravel; gravel-sand mixtures, little or no fines
	GP	Poorly-graded gravel; gravel-sand mixtures, little or no fines
<b>GRAVEL</b> More than 50% of coarse fraction larger than No. 4 sieve size	Gravel with fines (More than 12% fines)	
	GM	Silty gravel; gravel-sand-silt mixtures
	GC	Clayey gravel; gravel-sand-clay mixtures
	Clean Sand (Less than 5% fines)	
<b>SAND</b> 50% or more of coarse fraction smaller than No. 4 sieve size	SW	Well-graded sand; sand-gravel mixtures, little or no fines
	SP	Poorly graded sand; sand-gravel mixtures, little or no fines
	Sand with fines (More than 12% fines)	
	SM	Silty sand; sand-silt-gravel mixtures
<b>SILT AND CLAY</b> Liquid limit less than 50%	SC	Clayey sand; sand-clay-gravel mixtures
	<b>FINE-GRAINED SOIL</b> (50% or more of material is smaller than No. 200 sieve size)	
	ML	Inorganic silt; sandy silt or gravelly silt with slight plasticity
<b>SILT AND CLAY</b> Liquid limit less than 50%	CL	Inorganic clay of low plasticity; lean clay, sandy clay, gravelly clay
	OL	Organic silt and organic clay of low plasticity
	<b>SILT AND CLAY</b> Liquid limit 50% or greater	MH
CH		Inorganic clay of high plasticity, fat clay
OH		Organic silt and organic clay of high plasticity
<b>HIGHLY ORGANIC SOIL</b>	PT	Peat and other highly organic soil

OTHER MATERIAL SYMBOLS		
	Topsoil	
	Void	
	Sandstone	
	Asphalt Concrete	
	Glacial Till	
	Siltstone	
	Aggregate Base	
	Coal	
	Limestone	
	Portland Cement Concrete	
	Shale	
	Fill	

LABORATORY CLASSIFICATION CRITERIA	
GW	$C_u = \frac{D_{60}}{D_{10}}$ greater than 4; $C_c = \frac{D_{30}^2}{D_{10} \times D_{60}}$ between 1 and 3
GP	Not meeting all gradation requirements for GW
GM	Atterberg limits below "A" line or PI less than 4
GC	Atterberg limits above "A" line with PI greater than 7
SW	$C_u = \frac{D_{60}}{D_{10}}$ greater than 6; $C_c = \frac{D_{30}^2}{D_{10} \times D_{60}}$ between 1 and 3
SP	Not meeting all gradation requirements for SW
SM	Atterberg limits below "A" line or PI less than 4
SC	Atterberg limits above "A" line with PI greater than 7

Determine percentages of sand and gravel from grain-size curve. Depending on percentage of fines (fraction smaller than No. 200 sieve size), coarse-grained soils are classified as follows:

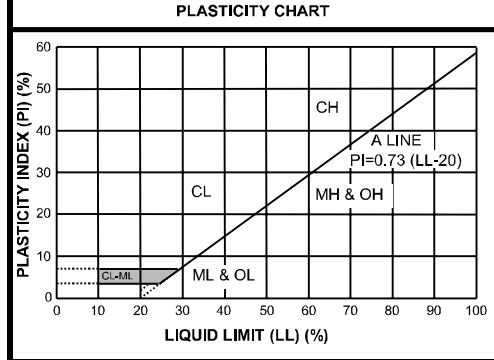
Less than 5 percent.....GW, GP, SW, SP  
 More than 12 percent.....GM, GC, SM, SC  
 5 to 12 percent.....Cases requiring dual symbols

- SP-SM or SW-SM (SAND with Silt or SAND with Silt and Gravel)
- SP-SC or SW-SC (SAND with Clay or SAND with Clay and Gravel)
- GP-GM or GW-GM (GRAVEL with Silt or GRAVEL with Silt and Sand)
- GP-GC or GW-GC (GRAVEL with Clay or GRAVEL with Clay and Sand)

If the fines are CL-ML:

- SC-SM (SILTY CLAYEY SAND or SILTY CLAYEY SAND with Gravel)
- SM-SC (CLAYEY SILTY SAND or CLAYEY SILTY SAND with Gravel)
- GC-GM (SILTY CLAYEY GRAVEL or SILTY CLAYEY GRAVEL with Sand)

PARTICLE SIZES	
Boulders	- Greater than 12 inches
Cobbles	- 3 inches to 12 inches
Gravel- Coarse	- 3/4 inches to 3 inches
Gravel- Fine	- No. 4 to 3/4 inches
Sand- Coarse	- No. 10 to No. 4
Sand- Medium	- No. 40 to No. 10
Sand- Fine	- No. 200 to No. 40
Silt and Clay	- Less than (0.074 mm)



VISUAL MANUAL PROCEDURE
When laboratory tests are not performed to confirm the classification of soils exhibiting borderline classifications, the two possible classifications would be separated with a slash, as follows:
For soils where it is difficult to distinguish if it is a coarse or fine-grained soil:
<ul style="list-style-type: none"> <li>• SC/CL (CLAYEY SAND to Sandy LEAN CLAY)</li> <li>• SW/ML (SILTY SAND to SANDY SILT)</li> <li>• GC/CL (CLAYEY GRAVEL to Gravelly LEAN CLAY)</li> <li>• GM/ML (SILTY GRAVEL to Gravelly SILT)</li> </ul>
For soils where it is difficult to distinguish if it is sand or gravel, poorly or well-graded sand or gravel; silt or clay; or plastic or non-plastic silt or clay:
<ul style="list-style-type: none"> <li>• SP/GP or SW/GW (SAND with Gravel to GRAVEL with Sand)</li> <li>• SC/GC (CLAYEY SAND with Gravel to CLAYEY GRAVEL with Sand)</li> <li>• SM/GM (SILTY SAND with Gravel to SILTY GRAVEL with Sand)</li> <li>• SW/SP (SAND or SAND with Gravel)</li> <li>• GP/GW (GRAVEL or GRAVEL with Sand)</li> <li>• SC/SM (CLAYEY to SILTY SAND)</li> <li>• GM/GC (SILTY to CLAYEY GRAVEL)</li> <li>• CL/ML (SILTY CLAY)</li> <li>• ML/CL (CLAYEY SILT)</li> <li>• CH/MH (FAT CLAY to ELASTIC SILT)</li> <li>• CL/CH (LEAN to FAT CLAY)</li> <li>• MH/ML (ELASTIC SILT to SILT)</li> </ul>

DRILLING AND SAMPLING ABBREVIATIONS	
2ST	- Shelby Tube - 2" O.D.
3ST	- Shelby Tube - 3" O.D.
AS	- Auger Sample
GS	- Grab Sample
LS	- Liner Sample
NR	- No Recovery
PM	- Pressuremeter
RC	- Rock Core diamond bit, NX size, except where noted
SB	- Split Barrel Sample 1-3/8" I.D., 2" O.D., except where noted
VS	- Vane Shear
WS	- Wash Sample

OTHER ABBREVIATIONS	
WOH	- Weight of Hammer
WOR	- Weight of Rods
SP	- Soil Probe
PID	- Photo Ionization Device
FID	- Flame Ionization Device

DEPOSITIONAL FEATURES	
Parting	- as much as 1/16 inch thick
Seam	- 1/16 inch to 1/2 inch thick
Layer	- 1/2 inch to 12 inches thick
Stratum	- greater than 12 inches thick
Pocket	- deposit of limited lateral extent
Lens	- lenticular deposit
Hardpan/Till	- an unstratified, consolidated or cemented mixture of clay, silt, sand and/or gravel, the size/shape of the constituents vary widely
Lacustrine	- soil deposited by lake water
Mottled	- soil irregularly marked with spots of different colors that vary in number and size
Varved	- alternating partings or seams of silt and/or clay
Occasional	- one or less per foot of thickness
Frequent	- more than one per foot of thickness
Interbedded	- strata of soil or beds of rock lying between or alternating with other strata of a different nature

DESCRIPTION OF RELATIVE QUANTITIES	
The visual-manual procedure uses the following terms to describe the relative quantities of notable foreign materials, gravel, sand or fines:	
Trace	- particles are present but estimated to be less than 5%
Few	- 5 to 10%
Little	- 15 to 25%
Some	- 30 to 45%
Mostly	- 50 to 100%

CLASSIFICATION TERMINOLOGY AND CORRELATIONS			
<b>Cohesionless Soils</b>		<b>Cohesive Soils</b>	
<b>Relative Density</b>	<b>N<sub>60</sub> (N-Value) (Blows per foot)</b>	<b>Consistency</b>	<b>N<sub>60</sub> (N-Value) (Blows per foot)</b>
Very Loose	0 to 4	Very Soft	<2
Loose	5 to 10	Soft	2 - 4
Medium Dense	11 to 30	Medium	5 - 8
Dense	31 to 50	Stiff	9 - 15
Very Dense	51 to 80	Very Stiff	16 - 30
Extremely Dense	Over 81	Hard	> 30
		<b>Undrained Shear Strength (kips/ft<sup>2</sup>)</b>	
		< 0.25	< 0.25 or less
		> 0.25	> 0.25 to 0.50
		> 0.50	> 0.50 to 1.0
		> 1.0	> 1.0 to 2.0
		> 2.0	> 2.0 to 4.0
		> 4.0	> 4.0 or greater

Standard Penetration 'N-Value' = Blows per foot of a 140-pound hammer falling 30 inches on a 2-inch O.D. split barrel sampler, except where noted. N60 values as reported on boring logs represent raw N-values corrected for hammer efficiency only.

4/12/24 8:26:33 AM



# BORING B4

PAGE 1 OF 1

BORING DEPTH: 10 FEET

**PROJECT NAME:** Barton-Bandemer Tunnel

**PROJECT NUMBER:** 080118.00

**CLIENT:** Colliers Engineering & Design

**PROJECT LOCATION:** Ann Arbor, Washtenaw County, Michigan

**DATE STARTED:** 1/19/23

**COMPLETED:** 1/19/23

**BORING METHOD:** Solid-stem Augers

**DRILLER:** RM

**RIG NO.:** 531 (CME55LCX)

**LOGGED BY:** TAG

**CHECKED BY:** STR

ELEVATION (FEET)	DEPTH (FEET)	SYMBOLIC PROFILE	LATITUDE: 42.30236 LONGITUDE: -83.74871 STATION: Approx. Sta. 135+80 LOCATION: 5 ft. Lt of CL ELEVATION: 788± FT	PROFILE DESCRIPTION	SAMPLE TYPE/NO. INTERVAL	RECOVERY LENGTH (INCHES)	SPT BLOWS PER SIX INCHES	HAMMER EFFICIENCY: 80% DATE: 11/11/2021 $N_{60} - O$	DRY DENSITY (pcf) - ■	MOISTURE & ATTERBERG LIMITS (%)	▼ HAND PENE ■ TORVANE SHEAR ○ UNC. COMP. □ VANE SHEAR (PK) × VANE SHEAR (REM) ◆ TRIAXIAL (UU) SHEAR STRENGTH (KSF)	REMARKS
									90 100 110 120	PL MC LL		
	0			14 Inches of Fine to Medium SAND (SP)								
	1.2				SB1	18	4	4				
	785			Fine to Medium CLAYEY SAND with Gravel- Brown- Moist- Very Loose to Medium Dense (SC)	SB2	18	2	12				
	5						6					
	6.5				SB3	18	3	8			0.6	
	780			LEAN CLAY- Brown- Medium to Very Stiff (CL)			3					
	10				SB4	18	5	20				
	10.0			END OF BORING AT 10.0 FEET.			7					
	775						8					
	15											
	770											
	20											
	765											
	25											
	760											
	30											
	755											
	35											

<b>GROUNDWATER &amp; BACKFILL INFORMATION</b>
GROUNDWATER WAS NOT ENCOUNTERED
<b>BACKFILL METHOD:</b> Bentonite Chips

NOTES: 1. The indicated stratification lines are approximate. The in-situ transitions between materials may be gradual.  
 2. The colors depicted on the symbolic profile are solely for visualization purposes and do not necessarily represent the in-situ colors encountered.  
 3. Latitude and longitude obtained with a Geode GNS2 Submeter GPS unit. Estimated ground surface elevation is based on available project drawings.

4/12/24 8:26:34 AM



# BORING B5

PAGE 1 OF 1

BORING DEPTH: 30 FEET

**PROJECT NAME:** Barton-Bandemer Tunnel

**PROJECT NUMBER:** 080118.00

**CLIENT:** Colliers Engineering & Design

**PROJECT LOCATION:** Ann Arbor, Washtenaw County, Michigan

**DATE STARTED:** 1/19/23

**COMPLETED:** 1/19/23

**BORING METHOD:** Hollow-stem Augers

**DRILLER:** RM

**RIG NO.:** 531 (CME55LCX)

**LOGGED BY:** TAG

**CHECKED BY:** STR

ELEVATION (FEET)	DEPTH (FEET)	SYMBOLIC PROFILE	LATITUDE: 42.30233 LONGITUDE: -83.74815 STATION: Approx. Sta. 136+90 LOCATION: 5 ft. Rt of CL ELEVATION: 781± FT	PROFILE DESCRIPTION	SAMPLE TYPE/NO. INTERVAL	RECOVERY LENGTH (INCHES)	SPT BLOWS PER SIX INCHES	HAMMER EFFICIENCY: 80% DATE: 11/11/2021 N <sub>60</sub> - O	DRY DENSITY (pcf) - ■				MOISTURE & ATTERBERG LIMITS (%)				REMARKS
									90	100	110	120	PL	MC	LL	SH	
780	0			15 Inches of TOPSOIL													
	1.3																
	2.0			Fine SILTY SAND- Brown- Moist- Loose (SM)	SB1	18	2	7									
	5			Fine to Medium SILTY SAND - Brown- Moist- Loose (SM)	SB2	18	3	8									
	5.5			Fine to Coarse SAND with Silt and Gravel- Brown- Wet- Dense (SP-SM)	SB3	1	19	37									
	7.0				SB4	18	5	20									
	10			LEAN CLAY- Frequent Silty Clay Layers between 7 and 9 feet- Gray- Very Stiff to Hard (CL)	SB5	18	6	19									
	15				SB6	18	8	24									
	15.0				SB7	18	8	28									
	20			SILTY CLAY with Sand- Gray- Hard (CL/ML)	SB8	18	7	31									
	25				SB9	18	15	53									
	27.5			Fine to Medium SILTY SAND- Gray- Wet- Very Dense (SM)	SB10	18	18	71									
	30.0			END OF BORING AT 30.0 FEET.													

Driller reported driving cobble.

GROUNDWATER & BACKFILL INFORMATION		
	DEPTH (FT)	ELEV (FT)
▽ DURING BORING:	5.5	775.5
▽ AT END OF BORING:	24.0	757.0
<b>BACKFILL METHOD:</b> Auger Cuttings 0 to 5 feet, Bentonite Chips and Cement 5 to 30 feet		

NOTES: 1. The indicated stratification lines are approximate. The in-situ transitions between materials may be gradual.  
 2. The colors depicted on the symbolic profile are solely for visualization purposes and do not necessarily represent the in-situ colors encountered.  
 3. Latitude and longitude obtained with a Geode GNS2 Submeter GPS unit. Estimated ground surface elevation is based on available project drawings.



4/12/24 8:26:35 AM



# BORING B6

PAGE 1 OF 1

BORING DEPTH: 30 FEET

**PROJECT NAME:** Barton-Bandemer Tunnel

**PROJECT NUMBER:** 080118.00

**CLIENT:** Colliers Engineering & Design

**PROJECT LOCATION:** Ann Arbor, Washtenaw County, Michigan

**DATE STARTED:** 1/19/23

**COMPLETED:** 1/19/23

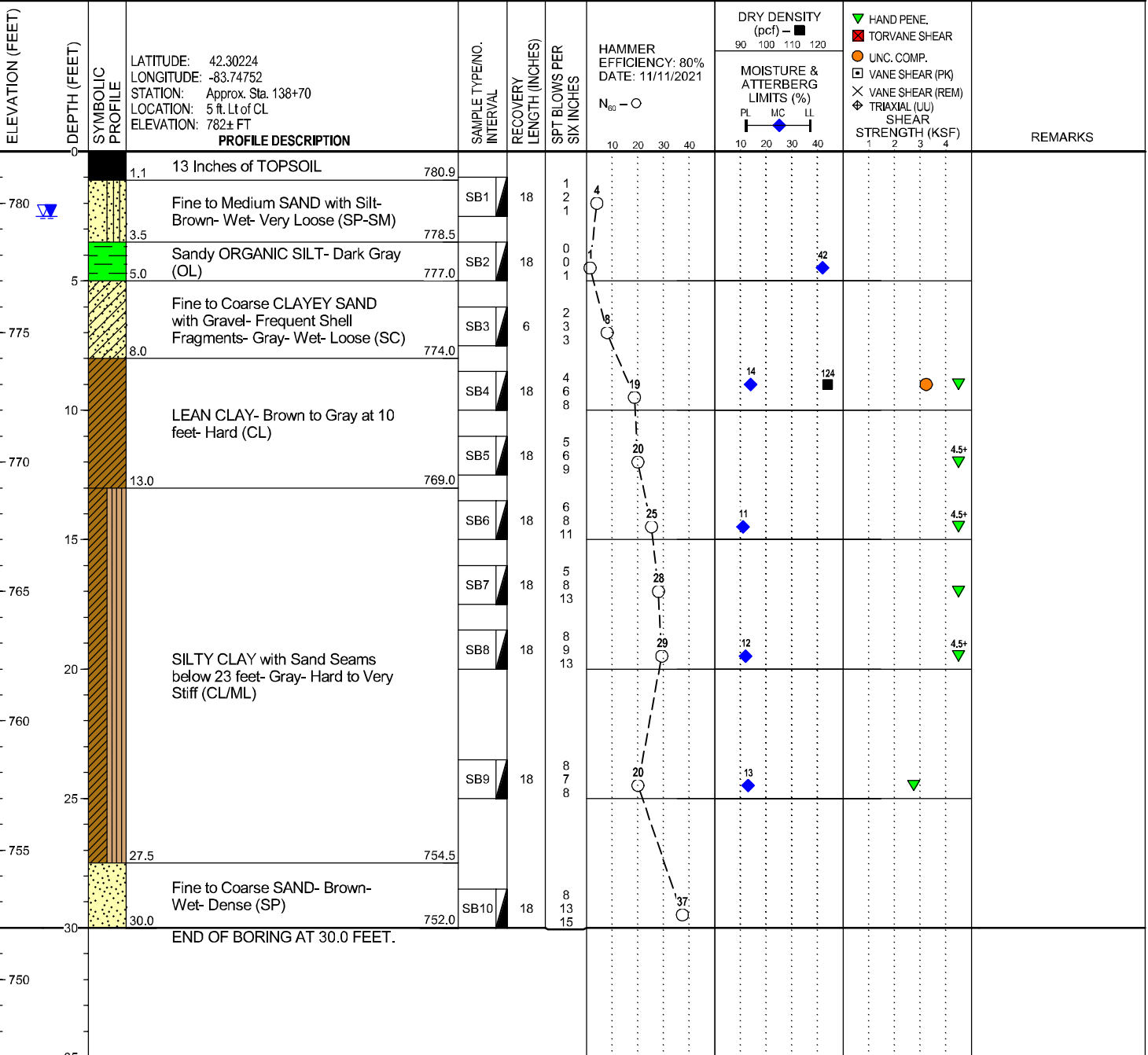
**BORING METHOD:** Hollow-stem Augers

**DRILLER:** RM

**RIG NO.:** 531 (CME55LCX)

**LOGGED BY:** TAG

**CHECKED BY:** STR



GROUNDWATER & BACKFILL INFORMATION		
	DEPTH (FT)	ELEV (FT)
▽ DURING BORING:	2.5	779.5
▽ AT END OF BORING:	2.5	779.5
<b>BACKFILL METHOD:</b>	Auger Cuttings 0 to 5 feet, Bentonite Chips and Cement 5 to 30 feet	

NOTES: 1. The indicated stratification lines are approximate. The in-situ transitions between materials may be gradual.  
 2. The colors depicted on the symbolic profile are solely for visualization purposes and do not necessarily represent the in-situ colors encountered.  
 3. Latitude and longitude obtained with a Geode GNS2 Submeter GPS unit. Estimated ground surface elevation is based on available project drawings.

4/12/24 8:26:36 AM



# BORING B7

PAGE 1 OF 2

BORING DEPTH: 50 FEET

**PROJECT NAME:** Barton-Bandemer Tunnel

**PROJECT NUMBER:** 080118.00

**CLIENT:** Colliers Engineering & Design

**PROJECT LOCATION:** Ann Arbor, Washtenaw County, Michigan

**DATE STARTED:** 3/21/22

**COMPLETED:** 3/21/22

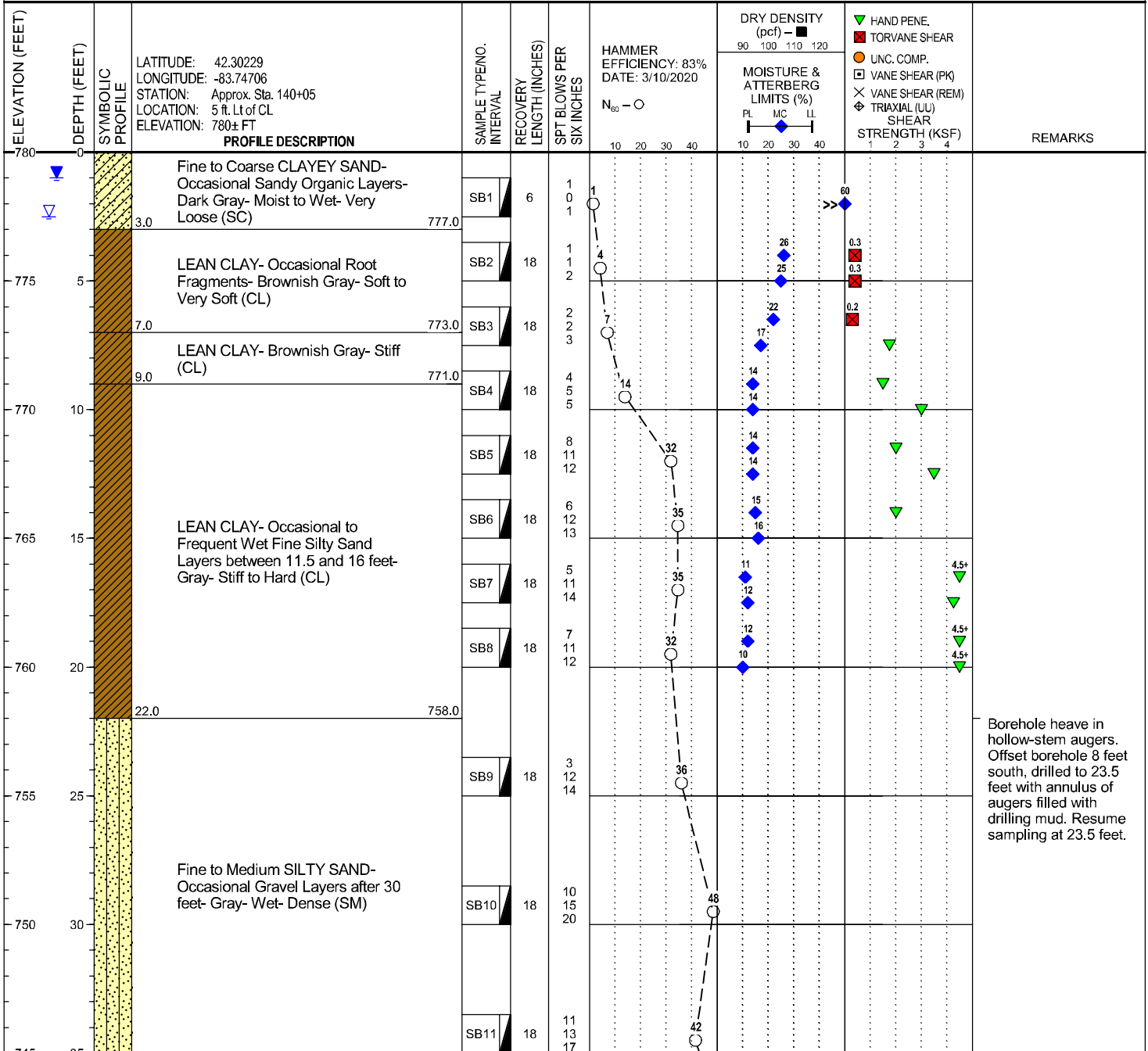
**BORING METHOD:** HSA 0' to 50', Fluid 22' to 50'

**DRILLER:** RM

**RIG NO.:** 531 (CME55LCX)

**LOGGED BY:** KJT

**CHECKED BY:** PDF



Borehole heave in hollow-stem augers. Offset borehole 8 feet south, drilled to 23.5 feet with annulus of augers filled with drilling mud. Resume sampling at 23.5 feet.

GROUNDWATER & BACKFILL INFORMATION		
	DEPTH (FT)	ELEV (FT)
▽ DURING BORING:	2.5	777.5
▽ AT END OF BORING:	1.0	779.0
<b>BACKFILL METHOD:</b>	Note 3	

- NOTES: 1. The indicated stratification lines are approximate. The in-situ transitions between materials may be gradual.  
 2. The colors depicted on the symbolic profile are solely for visualization purposes and do not necessarily represent the in-situ colors encountered.  
 3. Borehole backfilled with cement-bentonite grout from 50 feet to 5 feet below the ground surface and auger cuttings above 5 feet to the ground surface.  
 4. Latitude and longitude obtained with a Geode GNS2 Submeter GPS unit. Estimated ground surface elevation is based on available project drawings.  
 5. Temporary piezometer installed at offset location.

4/12/24 8:26:36 AM



# BORING B7

PAGE 2 OF 2

BORING DEPTH: 50 FEET

**PROJECT NAME:** Barton-Bandemer Tunnel

**PROJECT NUMBER:** 080118.00

**CLIENT:** Colliers Engineering & Design

**PROJECT LOCATION:** Ann Arbor, Washtenaw County, Michigan

ELEVATION (FEET)	DEPTH (FEET)	SYMBOLIC PROFILE	LATITUDE: 42.30229 LONGITUDE: -83.74706 STATION: Approx. Sta. 140+05 LOCATION: 5 ft. Lt of CL ELEVATION: 780± FT	PROFILE DESCRIPTION	SAMPLE TYPE/NO. INTERVAL	RECOVERY LENGTH (INCHES)	SPT BLOWS PER SIX INCHES	HAMMER EFFICIENCY: 83% DATE: 3/10/2020 N <sub>60</sub> - ○	DRY DENSITY (pcf) - ■	MOISTURE & ATTERBERG LIMITS (%) Pl MC LL	STRENGTH (KSF)	REMARKS	
									90 100 110 120				1 2 3 4
745	35			Fine to Medium SILTY SAND- Occasional Gravel Layers after 30 feet- Gray- Wet- Dense (SM)									
	37.5			(continued)	742.5								
740	40						SB12	6	63	87+			
735	45			Fine to Medium SILTY SAND with Gravel- Occasional Cobbles- Brown- Extremely Dense to Very Dense (SM)									
	50.0				730.0								
730	50						NR14	0	22 25 31	77			
END OF BORING AT 50.0 FEET.													
725	55												
720	60												
715	65												
710	70												
705	75												
700	80												

HAND PENE.  
 TORVANE SHEAR  
 UNC. COMP.  
 VANE SHEAR (PK)  
 VANE SHEAR (REM)  
 TRIAXIAL (UU) SHEAR

4/12/24 8:26:37 AM



# BORING B8

PAGE 1 OF 2

BORING DEPTH: 58.7 FEET

**PROJECT NAME:** Barton-Bandemer Tunnel

**PROJECT NUMBER:** 080118.00

**CLIENT:** Colliers Engineering & Design

**PROJECT LOCATION:** Ann Arbor, Washtenaw County, Michigan

**DATE STARTED:** 1/19/23

**COMPLETED:** 1/19/23

**BORING METHOD:** Hollow-stem Augers

**DRILLER:** RM

**RIG NO.:** 531 (CME55LCX)

**LOGGED BY:** TAG

**CHECKED BY:** STR

ELEVATION (FEET)	DEPTH (FEET)	SYMBOLIC PROFILE	LATITUDE: 42.30243 LONGITUDE: -83.74679 STATION: Approx. Sta. 140+95 LOCATION: 5 ft. Lt of CL ELEVATION: 787± FT	PROFILE DESCRIPTION	SAMPLE TYPE/NO. INTERVAL	RECOVERY LENGTH (INCHES)	SPT BLOWS PER SIX INCHES	HAMMER EFFICIENCY: 80% DATE: 11/11/2021 N <sub>60</sub> - O	DRY DENSITY (pcf) - ■		MOISTURE & ATTERBERG LIMITS (%)		▼ HAND PENE ■ TORVANE SHEAR ○ UNC. COMP. □ VANE SHEAR (PK) × VANE SHEAR (REM) ◆ TRIAXIAL (UU) SHEAR STRENGTH (KSF)	REMARKS
									90	100	110	120		
785.0	0.0			24 Inches of SANDY TOPSOIL	SB1	0	3	4						
783.0	2.0			FILL- Fine to Coarse SILTY SAND with Gravel- Occasional Cinder Pieces- Brown- Moist- Very Loose (SM)	SB2	10	2	5						
780.0	4.0			FILL- Fine to Coarse SAND with Gravel- Occasional Brick and Cinder Pieces above 7 feet- Occasional Lean Clay Layers at 19 feet- Brown- Moist to Wet- Loose (SP)	SB3	6	2	5						
775.5	11.5			Sandy LEAN CLAY with Organics- Black (CL)	SB4	10	2	5						
774.0	13.0				SB5	18	1	5						
770.0	15.0			LEAN CLAY with Sand- Gray- Very Stiff to Hard (CL)	SB6	18	6	19	15	21			4.5+	
765.0	23.0				SB7	18	6	20	14					
760.0	29.0			SILTY CLAY with Sand- Gray- Hard (CL/ML)	SB8	18	6	20	12					4.5+
755.0	33.5			Fine to Medium CLAYEY SAND- Dense- Gray- Wet- Very Dense (SC)	SB9	18	6	24	10					4.5+
					SB10	11	12	51						4.5+
					SB11	18	7	37						

GROUNDWATER & BACKFILL INFORMATION		
	DEPTH (FT)	ELEV (FT)
▽ DURING BORING:	8.5	778.5
▽ AT END OF BORING:	Note 3	
BACKFILL METHOD:	Note 4	

- NOTES: 1. The indicated stratification lines are approximate. The in-situ transitions between materials may be gradual.  
 2. The colors depicted on the symbolic profile are solely for visualization purposes and do not necessarily represent the in-situ colors encountered.  
 3. Wash water used in hollow-stem augers below a depth of 15 feet, therefore, an accurate groundwater level measurement was not obtained after the completion of drilling activities.  
 4. Borehole backfilled with cement-bentonite grout from 60 feet to 5 feet below the ground surface and auger cuttings above 5 feet to the ground surface.  
 5. Latitude and longitude obtained with a Geode GNS2 Submeter GPS unit. Estimated ground surface elevation is based on available project drawings.

(Continued Next Page)

4/12/24 8:26:37 AM



# BORING B8

PAGE 2 OF 2

BORING DEPTH: 58.7 FEET

**PROJECT NAME:** Barton-Bandemer Tunnel

**PROJECT NUMBER:** 080118.00

**CLIENT:** Colliers Engineering & Design

**PROJECT LOCATION:** Ann Arbor, Washtenaw County, Michigan

ELEVATION (FEET)	DEPTH (FEET)	SYMBOLIC PROFILE	LATITUDE: 42.30243 LONGITUDE: -83.74679 STATION: Approx. Sta. 140+95 LOCATION: 5 ft. Lt of CL ELEVATION: 787± FT	PROFILE DESCRIPTION	SAMPLE TYPE/NO. INTERVAL	RECOVERY LENGTH (INCHES)	SPT BLOWS PER SIX INCHES	HAMMER EFFICIENCY: 80% DATE: 11/11/2021 N <sub>60</sub> - ○	DRY DENSITY (pcf) - ■		MOISTURE & ATTERBERG LIMITS (%)		STRENGTH (KSF)	REMARKS
									90	100	PL	MC		
750	35	[Symbolic Profile: Fine to Coarse SAND with Gravel-Gray- Wet- Dense to Very Dense (SP) (continued)]		Fine to Coarse SAND with Gravel-Gray- Wet- Dense to Very Dense (SP) (continued)	SB12	18	15	55						
745	40						18							
745	43.5	[Symbolic Profile: Fine SAND- Gray- Wet- Very Dense (SP)]		Fine SAND- Gray- Wet- Very Dense (SP)	SB13	18	12	60						
740	45						21							
740	47.0	[Symbolic Profile: LEAN CLAY- Gray- Hard (CL)]		LEAN CLAY- Gray- Hard (CL)	SB14	18	10	55		16		4.5+		
735	50						15							
735	55.0	[Symbolic Profile: Fine to Medium CLAYEY SAND- Gray- Wet- Extremely Dense (SC)]		Fine to Medium CLAYEY SAND- Gray- Wet- Extremely Dense (SC)	SB15	6	35	80+						
730	55						60/0"							
730	58.7	END OF BORING AT 58.7 FEET.			SB16	2	60/2"	80+						

4/12/24 8:26:39 AM



# BORING B9

PAGE 1 OF 2

BORING DEPTH: 52 FEET

**PROJECT NAME:** Barton-Bandemer Tunnel

**PROJECT NUMBER:** 080118.00

**CLIENT:** Colliers Engineering & Design

**PROJECT LOCATION:** Ann Arbor, Washtenaw County, Michigan

**DATE STARTED:** 1/18/23

**COMPLETED:** 1/18/23

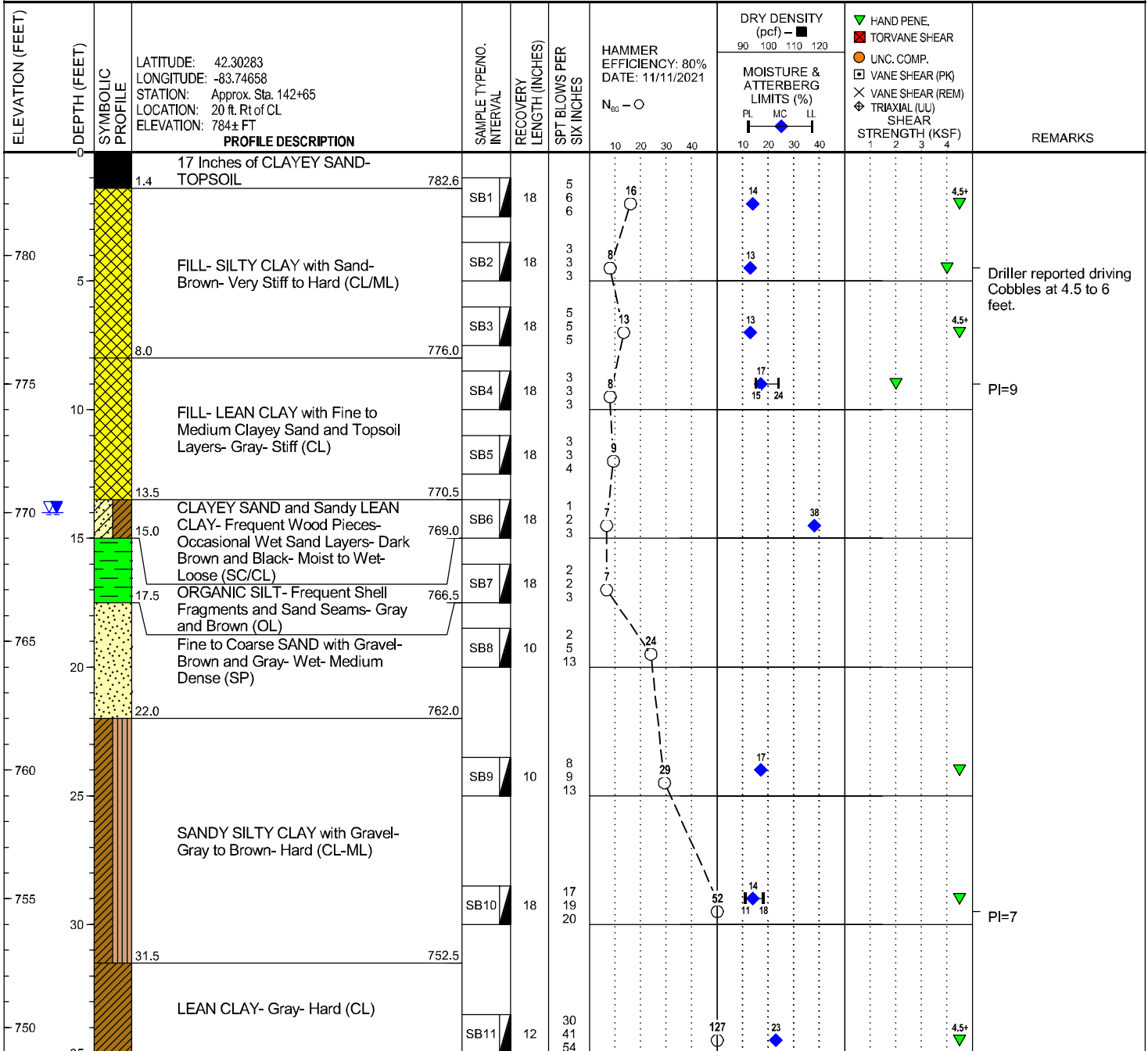
**BORING METHOD:** Hollow-stem Augers

**DRILLER:** RM

**RIG NO.:** 531 (CME55LCX)

**LOGGED BY:** TAG

**CHECKED BY:** STR



GROUNDWATER & BACKFILL INFORMATION		
	DEPTH (FT)	ELEV (FT)
▽ DURING BORING:	14.0	770.0
▽ AT END OF BORING:	14.0	770.0
BACKFILL METHOD:	Note 3	

NOTES: 1. The indicated stratification lines are approximate. The in-situ transitions between materials may be gradual.  
 2. The colors depicted on the symbolic profile are solely for visualization purposes and do not necessarily represent the in-situ colors encountered.  
 3. The borehole was backfilled by tremie method with cement-bentonite grout to 5 feet below the ground surface and auger cuttings to the ground surface.  
 4. Latitude and longitude obtained with a Geode GNS2 Submeter GPS unit. Estimated ground surface elevation is based on available project drawings.



3/27/24 3:04:49 PM



# WELL WB7

PAGE 1 OF 1

WELL DEPTH: 24 FEET

**PROJECT NAME:** Barton-Bandemer Tunnel

**PROJECT NUMBER:** 080118.00

**CLIENT:** Colliers Engineering & Design

**PROJECT LOCATION:** Ann Arbor, Washtenaw County, Michigan

**DATE STARTED:** 3/21/22

**COMPLETED:** 3/21/22

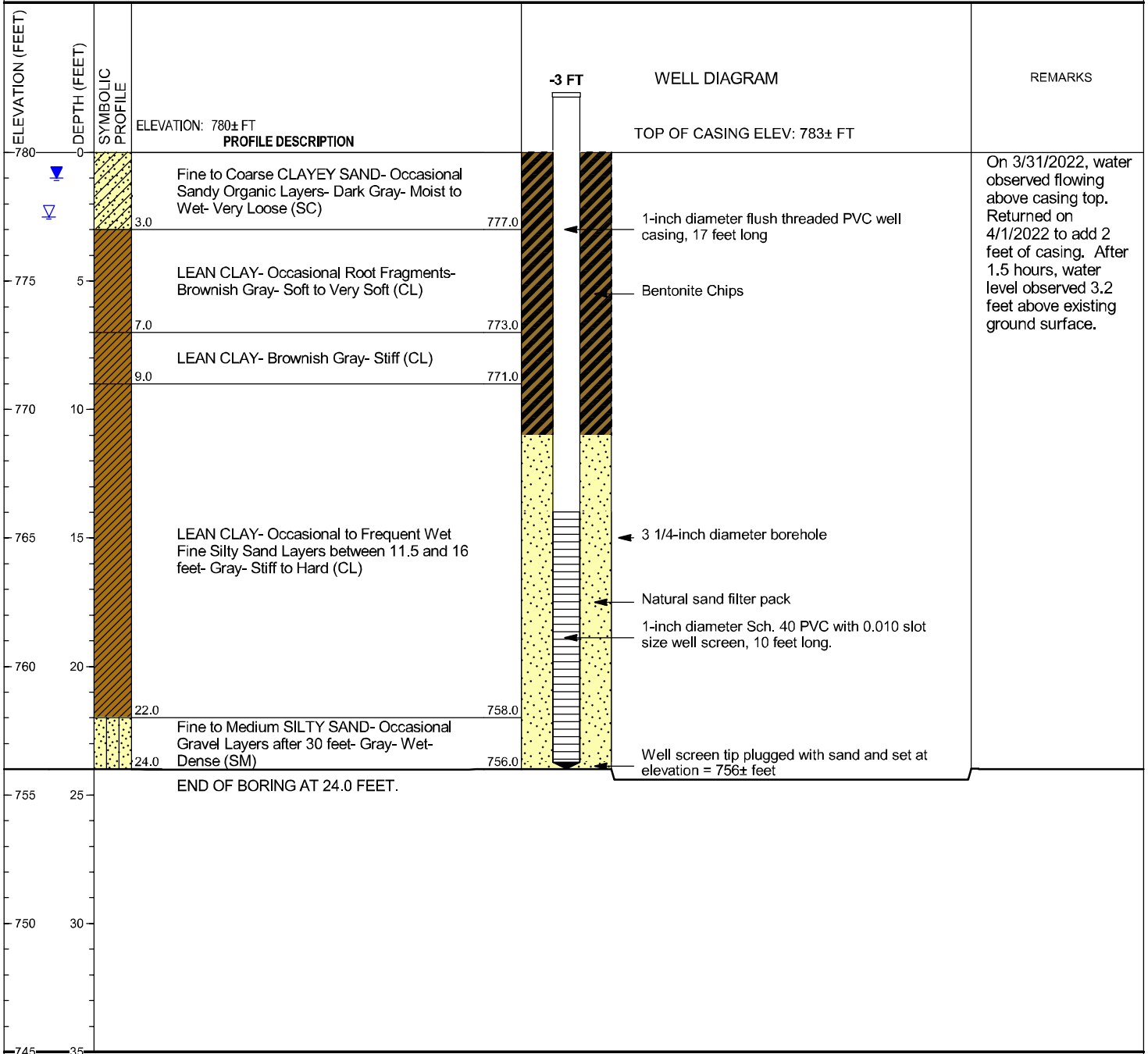
**BORING METHOD:** HSA 0' to 24'

**OPERATOR:** RM

**RIG NO.:** 531 (CME55LCX)

**LOGGED BY:** KJT

**CHECKED BY:** PDF



GROUNDWATER INFORMATION		
	DEPTH (FT)	ELEV (FT)
▽ DURING BORING:	2.5	777.5
▽ AT END OF BORING:	1.0	779.0
WELL WATER LEVEL DATA		
DATE	DEPTH (FT)	ELEV (FT)
3/31/2022		783+
4/1/2022		783.2

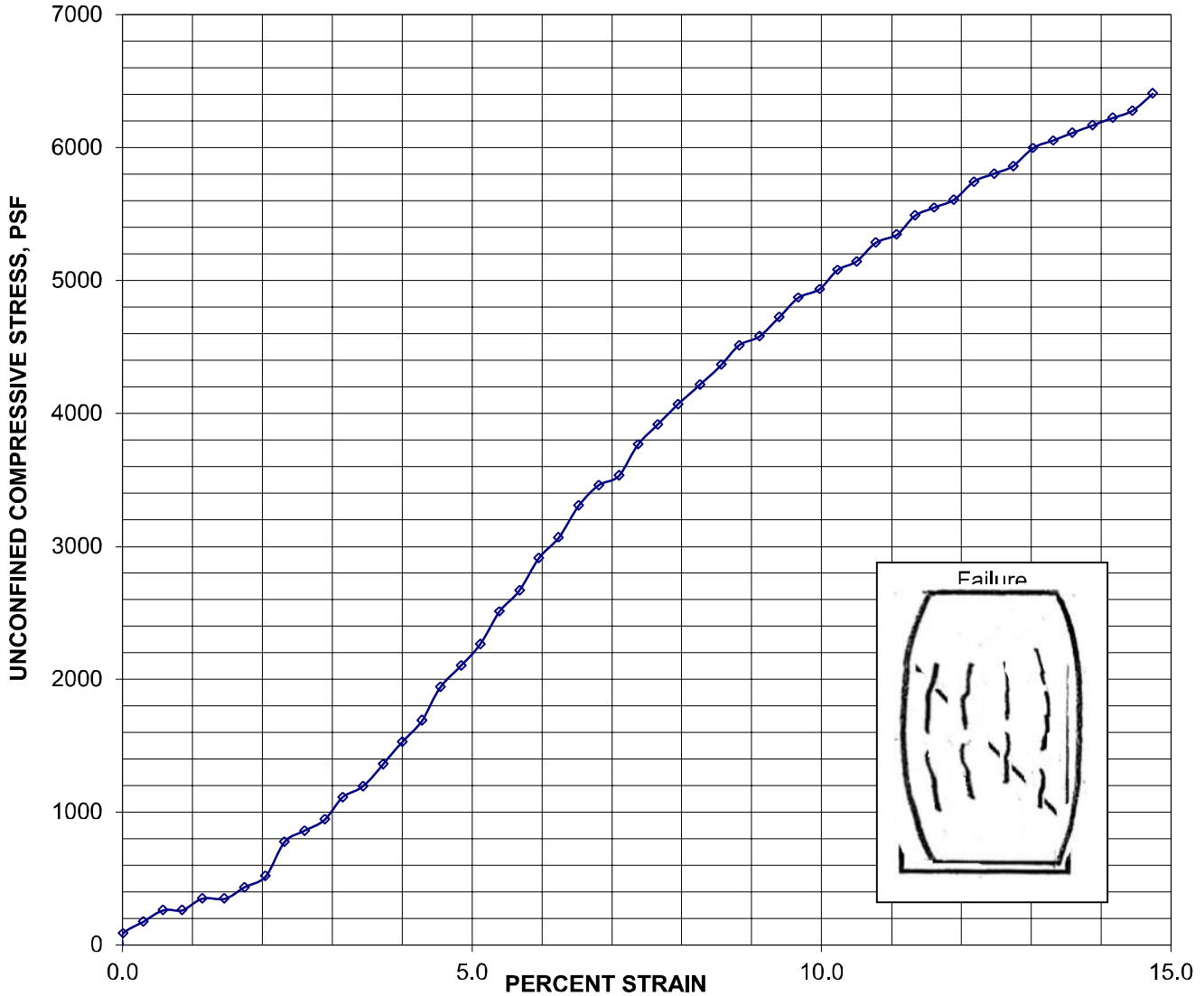
- NOTES:**
- The indicated stratification lines are approximate. The in-situ transitions between materials may be gradual.
  - The colors depicted on the symbolic profile are solely for visualization purposes and do not necessarily represent the in-situ colors encountered.
  - Well installed at offset location to Boring B7. Hollow-stem augers advanced to a depth of 24 feet below the existing ground surface and the well installed as noted above. A raised steel protective cover was installed at the surface.
  - The well was abandoned on April 8, 2022.
  - The entire well casing was removed.
  - Bentonite grout was placed using the tremie method from 24 feet up to 5 feet below ground surface, the remaining 5 feet was backfilled with hydrated bentonite chips.





**UNCONFINED COMPRESSIVE STRENGTH OF  
COHESIVE SOIL  
ASTM D2166**

**Project:** Barton-Bandemer Tunnel  
**Project #:** 080118.00  
**Date:** February 1, 2023

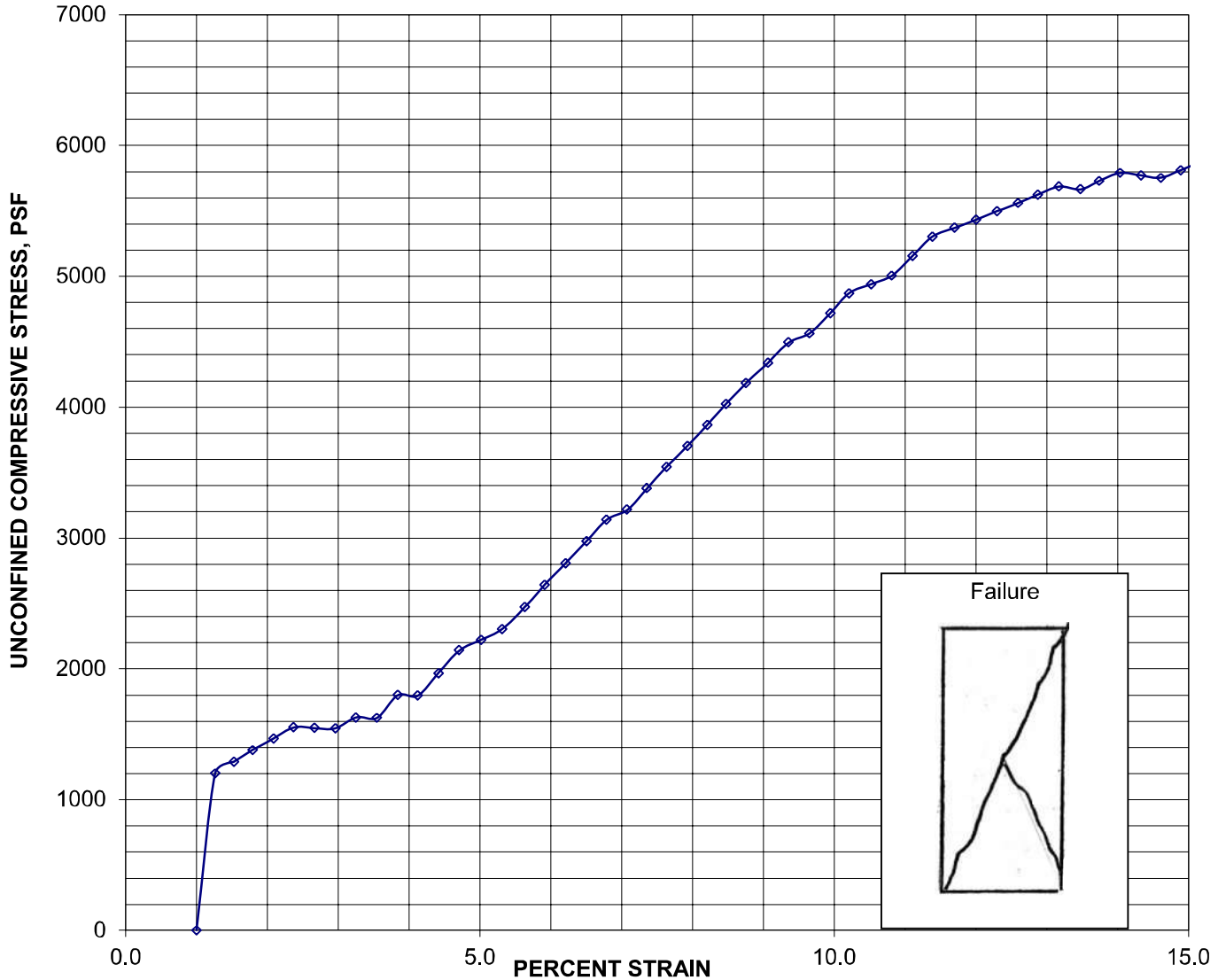


SAMPLE INFORMATION		TEST RESULTS	
<b>Sample Description:</b>	LEAN CLAY	<b>Unconfined Compressive Strength (psf):</b>	6460
<b>Sample Location:</b>	B6	<b>Strain at Failure (%):</b>	15.0
<b>Sample Depth:</b>	8.5 to 10 feet	<b>Water Content (after shear) (%):</b>	13.9
<b>USCS Classification:</b>	CL	<b>Dry Density (pcf):</b>	124.2
<b>Height (in):</b>	2.90	<b>Average Strain Rate (%/min):</b>	3.3
<b>Diameter (in):</b>	1.44		
<b>Height/Diameter Ratio:</b>	2.0	<b>Hand Penetrometer / Torvane:</b>	4.50



**UNCONFINED COMPRESSIVE STRENGTH OF  
COHESIVE SOIL  
ASTM D2166**

**Project:** Barton-Bandemer Tunnel  
**Project #:** 080118.00  
**Date:** February 1, 2023



SAMPLE INFORMATION		TEST RESULTS	
<b>Sample Description:</b>	LEAN CLAY with Sand	<b>Unconfined Compressive Strength (psf):</b>	5870
<b>Sample Location:</b>	B8	<b>Strain at Failure (%):</b>	15.2
<b>Sample Depth:</b>	13.5 to 15 feet	<b>Water Content (after shear) (%):</b>	12.8
<b>USCS Classification:</b>	CL	<b>Dry Density (pcf):</b>	121.3
<b>Height (in):</b>	2.83	<b>Average Strain Rate (%/min):</b>	1.8
<b>Diameter (in):</b>	1.40		
<b>Height/Diameter Ratio:</b>	2.0	<b>Hand Penetrometer / Torvane:</b>	4.5+

**APPENDIX B**  
**IMPORTANT INFORMATION ABOUT THIS GEOTECHNICAL-ENGINEERING REPORT**  
**GENERAL COMMENTS**  
**LABORATORY TESTING PROCEDURES**

# Important Information about This Geotechnical-Engineering Report

Subsurface problems are a principal cause of construction delays, cost overruns, claims, and disputes.

While you cannot eliminate all such risks, you can manage them. The following information is provided to help.

**The Geoprofessional Business Association (GBA) has prepared this advisory to help you – assumedly a client representative – interpret and apply this geotechnical-engineering report as effectively as possible. In that way, you can benefit from a lowered exposure to problems associated with subsurface conditions at project sites and development of them that, for decades, have been a principal cause of construction delays, cost overruns, claims, and disputes. If you have questions or want more information about any of the issues discussed herein, contact your GBA-member geotechnical engineer. Active engagement in GBA exposes geotechnical engineers to a wide array of risk-confrontation techniques that can be of genuine benefit for everyone involved with a construction project.**

## Understand the Geotechnical-Engineering Services Provided for this Report

Geotechnical-engineering services typically include the planning, collection, interpretation, and analysis of exploratory data from widely spaced borings and/or test pits. Field data are combined with results from laboratory tests of soil and rock samples obtained from field exploration (if applicable), observations made during site reconnaissance, and historical information to form one or more models of the expected subsurface conditions beneath the site. Local geology and alterations of the site surface and subsurface by previous and proposed construction are also important considerations. Geotechnical engineers apply their engineering training, experience, and judgment to adapt the requirements of the prospective project to the subsurface model(s). Estimates are made of the subsurface conditions that will likely be exposed during construction as well as the expected performance of foundations and other structures being planned and/or affected by construction activities.

The culmination of these geotechnical-engineering services is typically a geotechnical-engineering report providing the data obtained, a discussion of the subsurface model(s), the engineering and geologic engineering assessments and analyses made, and the recommendations developed to satisfy the given requirements of the project. These reports may be titled investigations, explorations, studies, assessments, or evaluations. Regardless of the title used, the geotechnical-engineering report is an engineering interpretation of the subsurface conditions within the context of the project and does not represent a close examination, systematic inquiry, or thorough investigation of all site and subsurface conditions.

## Geotechnical-Engineering Services are Performed for Specific Purposes, Persons, and Projects, and At Specific Times

Geotechnical engineers structure their services to meet the specific needs, goals, and risk management preferences of their clients. A geotechnical-engineering study conducted for a given civil engineer

will not likely meet the needs of a civil-works constructor or even a different civil engineer. Because each geotechnical-engineering study is unique, each geotechnical-engineering report is unique, prepared *solely* for the client.

Likewise, geotechnical-engineering services are performed for a specific project and purpose. For example, it is unlikely that a geotechnical-engineering study for a refrigerated warehouse will be the same as one prepared for a parking garage; and a few borings drilled during a preliminary study to evaluate site feasibility will not be adequate to develop geotechnical design recommendations for the project.

*Do not rely on this report* if your geotechnical engineer prepared it:

- for a different client;
- for a different project or purpose;
- for a different site (that may or may not include all or a portion of the original site); or
- before important events occurred at the site or adjacent to it; e.g., man-made events like construction or environmental remediation, or natural events like floods, droughts, earthquakes, or groundwater fluctuations.

Note, too, the reliability of a geotechnical-engineering report can be affected by the passage of time, because of factors like changed subsurface conditions; new or modified codes, standards, or regulations; or new techniques or tools. *If you are the least bit uncertain* about the continued reliability of this report, contact your geotechnical engineer before applying the recommendations in it. A minor amount of additional testing or analysis after the passage of time – if any is required at all – could prevent major problems.

## Read this Report in Full

Costly problems have occurred because those relying on a geotechnical-engineering report did not read the report in its entirety. Do not rely on an executive summary. Do not read selective elements only. *Read and refer to the report in full.*

## You Need to Inform Your Geotechnical Engineer About Change

Your geotechnical engineer considered unique, project-specific factors when developing the scope of study behind this report and developing the confirmation-dependent recommendations the report conveys. Typical changes that could erode the reliability of this report include those that affect:

- the site's size or shape;
- the elevation, configuration, location, orientation, function or weight of the proposed structure and the desired performance criteria;
- the composition of the design team; or
- project ownership.

As a general rule, *always* inform your geotechnical engineer of project or site changes – even minor ones – and request an assessment of their impact. *The geotechnical engineer who prepared this report cannot accept*

responsibility or liability for problems that arise because the geotechnical engineer was not informed about developments the engineer otherwise would have considered.

### Most of the “Findings” Related in This Report Are Professional Opinions

Before construction begins, geotechnical engineers explore a site’s subsurface using various sampling and testing procedures. *Geotechnical engineers can observe actual subsurface conditions only at those specific locations where sampling and testing is performed.* The data derived from that sampling and testing were reviewed by your geotechnical engineer, who then applied professional judgement to form opinions about subsurface conditions throughout the site. Actual sitewide-subsurface conditions may differ – maybe significantly – from those indicated in this report. Confront that risk by retaining your geotechnical engineer to serve on the design team through project completion to obtain informed guidance quickly, whenever needed.

### This Report’s Recommendations Are Confirmation-Dependent

The recommendations included in this report – including any options or alternatives – are confirmation-dependent. In other words, they are not final, because the geotechnical engineer who developed them relied heavily on judgement and opinion to do so. Your geotechnical engineer can finalize the recommendations *only after observing actual subsurface conditions* exposed during construction. If through observation your geotechnical engineer confirms that the conditions assumed to exist actually do exist, the recommendations can be relied upon, assuming no other changes have occurred. *The geotechnical engineer who prepared this report cannot assume responsibility or liability for confirmation-dependent recommendations if you fail to retain that engineer to perform construction observation.*

### This Report Could Be Misinterpreted

Other design professionals’ misinterpretation of geotechnical-engineering reports has resulted in costly problems. Confront that risk by having your geotechnical engineer serve as a continuing member of the design team, to:

- confer with other design-team members;
- help develop specifications;
- review pertinent elements of other design professionals’ plans and specifications; and
- be available whenever geotechnical-engineering guidance is needed.

You should also confront the risk of constructors misinterpreting this report. Do so by retaining your geotechnical engineer to participate in prebid and preconstruction conferences and to perform construction-phase observations.

### Give Constructors a Complete Report and Guidance

Some owners and design professionals mistakenly believe they can shift unanticipated-subsurface-conditions liability to constructors by limiting the information they provide for bid preparation. To help prevent the costly, contentious problems this practice has caused, include the complete geotechnical-engineering report, along with any attachments or appendices, with your contract documents, *but be certain to note*

*conspicuously that you’ve included the material for information purposes only.* To avoid misunderstanding, you may also want to note that “informational purposes” means constructors have no right to rely on the interpretations, opinions, conclusions, or recommendations in the report. Be certain that constructors know they may learn about specific project requirements, including options selected from the report, *only* from the design drawings and specifications. Remind constructors that they may perform their own studies if they want to, and *be sure to allow enough time* to permit them to do so. Only then might you be in a position to give constructors the information available to you, while requiring them to at least share some of the financial responsibilities stemming from unanticipated conditions. Conducting prebid and preconstruction conferences can also be valuable in this respect.

### Read Responsibility Provisions Closely

Some client representatives, design professionals, and constructors do not realize that geotechnical engineering is far less exact than other engineering disciplines. This happens in part because soil and rock on project sites are typically heterogeneous and not manufactured materials with well-defined engineering properties like steel and concrete. That lack of understanding has nurtured unrealistic expectations that have resulted in disappointments, delays, cost overruns, claims, and disputes. To confront that risk, geotechnical engineers commonly include explanatory provisions in their reports. Sometimes labeled “limitations,” many of these provisions indicate where geotechnical engineers’ responsibilities begin and end, to help others recognize their own responsibilities and risks. *Read these provisions closely.* Ask questions. Your geotechnical engineer should respond fully and frankly.

### Geoenvironmental Concerns Are Not Covered

The personnel, equipment, and techniques used to perform an environmental study – e.g., a “phase-one” or “phase-two” environmental site assessment – differ significantly from those used to perform a geotechnical-engineering study. For that reason, a geotechnical-engineering report does not usually provide environmental findings, conclusions, or recommendations; e.g., about the likelihood of encountering underground storage tanks or regulated contaminants. *Unanticipated subsurface environmental problems have led to project failures.* If you have not obtained your own environmental information about the project site, ask your geotechnical consultant for a recommendation on how to find environmental risk-management guidance.

### Obtain Professional Assistance to Deal with Moisture Infiltration and Mold

While your geotechnical engineer may have addressed groundwater, water infiltration, or similar issues in this report, the engineer’s services were not designed, conducted, or intended to prevent migration of moisture – including water vapor – from the soil through building slabs and walls and into the building interior, where it can cause mold growth and material-performance deficiencies. Accordingly, *proper implementation of the geotechnical engineer’s recommendations will not of itself be sufficient to prevent moisture infiltration.* **Confront the risk of moisture infiltration** by including building-envelope or mold specialists on the design team. *Geotechnical engineers are not building-envelope or mold specialists.*



Telephone: 301/565-2733

e-mail: [info@geoprofessional.org](mailto:info@geoprofessional.org) [www.geoprofessional.org](http://www.geoprofessional.org)

## GENERAL COMMENTS

### BASIS OF GEOTECHNICAL REPORT

This report has been prepared in accordance with generally accepted geotechnical engineering practices to assist in the design and/or evaluation of this project. If the project plans, design criteria, and other project information referenced in this report and utilized by SME to prepare our recommendations are changed, the conclusions and recommendations contained in this report are not considered valid unless the changes are reviewed, and the conclusions and recommendations of this report are modified or approved in writing by our office.

The discussions and recommendations submitted in this report are based on the available project information, described in this report, and the geotechnical data obtained from the field exploration at the locations indicated in the report. Variations in the soil and groundwater conditions commonly occur between or away from sampling locations. The nature and extent of the variations may not become evident until the time of construction. If significant variations are observed during construction, SME should be contacted to reevaluate the recommendations of this report. SME should be retained to continue our services through construction to observe and evaluate the actual subsurface conditions relative to the recommendations made in this report.

In the process of obtaining and testing samples and preparing this report, procedures are followed that represent reasonable and accepted practice in the field of soil and foundation engineering. Specifically, field logs are prepared during the field exploration that describe field occurrences, sampling locations, and other information. Samples obtained in the field are frequently subjected to additional testing and reclassification in the laboratory and differences may exist between the field logs and the report logs. The engineer preparing the report reviews the field logs, laboratory classifications, and test data and then prepares the report logs. Our recommendations are based on the contents of the report logs and the information contained therein.

### REVIEW OF DESIGN DETAILS, PLANS, AND SPECIFICATIONS

SME should be retained to review the design details, project plans, and specifications to verify those documents are consistent with the recommendations contained in this report.

### REVIEW OF REPORT INFORMATION WITH PROJECT TEAM

Implementation of our recommendations may affect the design, construction, and performance of the proposed improvements, along with the potential inherent risks involved with the proposed construction. The client and key members of the design team, including SME, should discuss the issues covered in this report so that the issues are understood and applied in a manner consistent with the owner's budget, tolerance of risk, and expectations for performance and maintenance.

### FIELD VERIFICATION OF GEOTECHNICAL CONDITIONS

SME should be retained to verify the recommendations of this report are properly implemented during construction. This may avoid misinterpretation of our recommendations by other parties and will allow us to review and modify our recommendations if variations in the site subsurface conditions are encountered.

### PROJECT INFORMATION FOR CONTRACTOR

This report and any future addenda or other reports regarding this site should be made available to prospective contractors prior to submitting their proposals for their information only and to supply them with facts relative to the subsurface evaluation and laboratory test results. If the selected contractor encounters subsurface conditions during construction, which differ from those presented in this report, the contractor should promptly describe the nature and extent of the differing conditions in writing and SME should be notified so that we can verify those conditions. The construction contract should include provisions for dealing with differing conditions and contingency funds should be reserved for potential problems during earthwork and foundation construction. We would be pleased to assist you in developing the contract provisions based on our experience.

The contractor should be prepared to handle environmental conditions encountered at this site, which may affect the excavation, removal, or disposal of soil; dewatering of excavations; and health and safety of workers. Any Environmental Assessment reports prepared for this site should be made available for review by bidders and the successful contractor.

### THIRD PARTY RELIANCE/REUSE OF THIS REPORT

This report has been prepared solely for the use of our Client for the project specifically described in this report. This report cannot be relied upon by other parties not involved in the project, unless specifically allowed by SME in writing. SME also is not responsible for the interpretation by other parties of the geotechnical data and the recommendations provided herein.

## LABORATORY TESTING PROCEDURES

### VISUAL ENGINEERING CLASSIFICATION

Visual classification was performed on recovered samples. The appended General Notes and Unified Soil Classification System (USCS) sheets include a brief summary of the general method used visually classify the soil and assign an appropriate USCS group symbol. The estimated group symbol, according to the USCS, is shown in parentheses following the textural description of the various strata on the boring logs appended to this report. The soil descriptions developed from visual classifications are sometimes modified to reflect the results of laboratory testing.

### MOISTURE CONTENT

Moisture content tests were performed by weighing samples from the field at their in-situ moisture condition. These samples were then dried at a constant temperature (approximately 110° C) overnight in an oven. After drying, the samples were weighed to determine the dry weight of the sample and the weight of the water that was expelled during drying. The moisture content of the specimen is expressed as a percent and is the weight of the water compared to the dry weight of the specimen.

### HAND PENETROMETER TESTS

In the hand penetrometer test, the unconfined compressive strength of a cohesive soil sample is estimated by measuring the resistance of the sample to the penetration of a small calibrated, spring-loaded cylinder. The maximum capacity of the penetrometer is 4.5 tons per square-foot (tsf). Theoretically, the undrained shear strength of the cohesive sample is one-half the unconfined compressive strength. The undrained shear strength (based on the hand penetrometer test) presented on the boring logs is reported in units of kips per square-foot (ksf).

### TORVANE SHEAR TESTS

In the Torvane test, the shear strength of a low strength, cohesive soil sample is estimated by measuring the resistance of the sample to a torque applied through vanes inserted into the sample. The undrained shear strength of the samples is measured from the maximum torque required to shear the sample and is reported in units of kips per square-foot (ksf).

### LOSS-ON-IGNITION (ORGANIC CONTENT) TESTS

Loss-on-ignition (LOI) tests are conducted by first weighing the sample and then heating the sample to dry the moisture from the sample (in the same manner as determining the moisture content of the soil). The sample is then re-weighed to determine the dry weight and then heated for 4 hours in a muffle furnace at a high temperature (approximately 440° C). After cooling, the sample is re-weighed to calculate the amount of ash remaining, which in turn is used to determine the amount of organic matter burned from the original dry sample. The organic matter content of the specimen is expressed as a percent compared to the dry weight of the sample.

### ATTERBERG LIMITS TESTS

Atterberg limits tests consist of two components. The plastic limit of a cohesive sample is determined by rolling the sample into a thread and the plastic limit is the moisture content where a 1/8-inch thread begins to crumble. The liquid limit is determined by placing a 1/2-inch thick soil pat into the liquid limits cup and using a grooving tool to divide the soil pat in half. The cup is then tapped on the base of the liquid limits device using a crank handle. The number of drops of the cup to close the gap formed by the grooving tool 1/2 inch is recorded along with the corresponding moisture content of the sample. This procedure is repeated several times at different moisture contents and a graph of moisture content, and the corresponding number of blows is plotted. The liquid limit is defined as the moisture content at a nominal 25 drops of the cup. From this test, the plasticity index can be determined by subtracting the plastic limit from the liquid limit.

## GRAIN SIZE DISTRIBUTION ANALYSIS

### COARSE-GRAINED (GRANULAR) SAMPLES WITH LOW FINES CONTENT

Grain size distribution tests performed on granular samples involves oven-drying a representative sample of soil and washing out the fines (passing the No. 200 sieve) with tap water. The sample retained on the No. 200 sieve is then oven-dried, cooled and sieved on a series of stacked sieves beginning with the largest sieve on top and progressing to the smallest on the bottom. The portions of the sample retained on each sieve are then weighed and used to develop the grain size distribution curve in the report for each sample tested.

### FINE-GRAINED (SILT OR CLAY) SAMPLES OR COARSE-GRAINED SAMPLES WITH HIGH FINES CONTENT

Particle size distribution tests performed on fine-grained or coarse-grained samples with a high fines content involves oven-drying a representative sample and mixing the sample with a liquid deflocculant to disperse the soil particles. The slurry is placed in a graduated cylinder and shaken to suspend the soil particles in the slurry. The graduated cylinder is then placed on a tabletop; a calibrated hydrometer is floated in the slurry to determine its density. The hydrometer measurements are made at selected time intervals as the soil in the cylinder settles and slurry density decreases. When the hydrometer measurements are completed, the slurry is poured onto a No. 200 sieve and the fines are washed out with tap water. The sample retained on the No. 200 sieve is then oven-dried, cooled and sieved on a series of stacked sieves beginning with the largest sieve on top and progressing to the smallest on the bottom. The portions of the sample retained on each sieve are then weighed and used with the hydrometer data to develop the grain size distribution curve in the report for each sample tested.

## WET/DRY DENSITY TESTS

Wet/dry density tests involve extracting a representative soil sample from either a Shelby tube or sample liner, trimming the ends perpendicular to the length of the sample and measuring the length and diameter. The sample is then weighed, oven-dried and weighed again after drying. The wet density is equal to the wet weight of the sample (prior to drying) divided by the volume, while the dry density is the dry weight of the sample divided by the volume.

## UNCONFINED COMPRESSIVE STRENGTH TESTS

In addition to the hand penetrometer and Torvane tests, unconfined compression tests were performed to better estimate the undrained shear strength of selected cohesive samples recovered from either Shelby tubes or liners taken in conjunction with the Standard Penetration Test. In the unconfined compression test, the unconfined compressive strength of a soil sample is determined by axially loading the soil sample at a slow, constant rate of strain. The unconfined compressive strength is the maximum compressive stress in the soil sample, up to 15 percent strain. Theoretically, the undrained shear strength of the cohesive sample is one-half the unconfined compressive strength. The undrained shear strength presented on the boring logs is reported in units of kips per square-foot (ksf).

## CORROSION TESTS

The soil corrosion tests may include measuring the electrical resistivity, pH and concentrations of soluble chlorides and sulfates. Soil samples tested are generally taken from a composite of two or more selected soil samples with generally similar visual characteristics. The electrical resistivity of the selected soil samples was performed on natural-state and saturated samples using a Miller multi-combination meter with a soil box configured in a four-pin arrangement. pH tests are typically conducted using litmus test paper. The soil samples for the soluble sulfates and chlorides were prepared as a water-soil solution, typically at a water-to-soil ratio of 20:1, and tested in general accordance with local laboratory methods for measuring sulfate and chloride concentrations.

## MOISTURE-DRY DENSITY RELATIONSHIPS (COMPACTION) TESTS

Moisture-dry density tests involve the preparation of a bulk soil sample by compacting the sample at a given energy into a calibrated mold with a known volume of 0.0333 cubic feet at various moisture contents. A graph of the moisture content vs. dry density is developed, which results in an inverted U-shaped curve. The maximum dry density is the peak of the curve and the corresponding moisture content is the optimum moisture. Two methods can be performed, namely:



## STANDARD PROCTOR METHOD

This method involves a standard energy of 12,400 ft-lbs per cubic foot of soil volume to compact the sample. The sample is compacted in three layers of equal thickness using a 5.5-pound hammer dropped 12 inches using 25 blows per layer.

## MODIFIED PROCTOR METHOD

This method involves a modified energy of 56,000 ft-lbs per cubic foot of soil volume to compact the sample. The sample is compacted in five layers of equal thickness using a 10-pound hammer dropped 18 inches using 25 blows per layer.

## SPECIFIC GRAVITY TESTS

This test involves the determination of the ratio of the weight of a known volume of soil particles in air to weight of the same volume of water in air. The test is performed by oven drying a soil sample and placing the sample with water into a calibrated pycnometer, boiling the soil/water mixture, filling the pycnometer with distilled water to its calibration mark, weighing the pycnometer and soil/water mixture and measuring the temperature of the mixture. The specific gravity is equal to the weight of the dry soil particles multiplied by the specific gravity of distilled water at the temperature measured for the soil/water mixture divided by the sum of the weight of the dry soil particles plus the weight of the pycnometer, soil/water mixture plus the weight of the pycnometer plus water from the calibration curve developed for the pycnometer.

## DIRECT SHEAR TESTS

A bulk sample is compacted in a direct shear mold at a specified density and moisture content. Shear tests are then performed using the direct shear procedure. The direct shear test is performed at several overburden pressures or normal stresses that represent approximate potential stresses in the proposed construction. Values of both peak friction angle and residual friction angle are determined from the tests for each overburden pressure. The results of the direct shear tests are tabulated and plotted on the Direct Shear Test Plots in Appendix A.

## CONSOLIDATION TESTS

Consolidation tests are used to evaluate the magnitude and rate of consolidation of soil when it is restrained laterally and drained on the top and bottom while subjected to vertical load applied in controlled increments. The range of test loads applied is generally selected to represent the anticipated vertical stress conditions resulting from existing conditions and the proposed construction. Plots of the percent strain vs. log pressure are constructed from the data to assess consolidation characteristics, while the rate of consolidation is evaluated from plots of deformation vs. time for each vertical load increment.

## PERMEABILITY TESTS

The permeability of either relatively undisturbed or compacted soils can be determined by various laboratory test equipment including a triaxial cell, permeameter mold or from a liner sample. The type of permeability equipment used and test performed will be based on the soil type being evaluated.

## CLAY, SILT AND OTHER LOW PERMEABLE SOIL SAMPLES

For samples with relatively low permeability characteristics, an undisturbed or compacted soil sample is placed in a triaxial cell. Prior to performing the permeability test, the sample must be fully saturated by forcing water into the sample using a backpressure (water under pressure from an air supply) which is slightly less than the cell pressure. Once the sample is saturated, water is forced through the top of the sample with pressure from an air supply (which is slightly less than the cell pressure) and water forced out of the bottom of the sample is measured in a burette. The volume of water displaced from the sample is recorded with time and from that information, the coefficient of permeability is calculated. This method is a constant head permeability test.

## SAND SAMPLES

Due to the nature of relatively clean granular soils, the use of a triaxial cell is generally not practical and the permeability of these types of soils is typically determined from either a liner sample (either recovered directly from a split-spoon in the field or a sample compacted in the liner) or a bulk sample compacted in a 6-inch diameter permeameter mold. A falling head permeability test can be performed on most granular samples by filling a standpipe with water and measuring the head drop with time. For highly permeable soils, the rate of drop in a falling head test may be too rapid to obtain reliable volume and time measurements. Thus, a constant head test will be required where a constant head of water is maintained, and the volume of water discharged from the sample is measured with time.

## TRIAXIAL TESTS

Triaxial tests were conducted on samples trimmed from Shelby tubes or liners. There are several types of triaxial tests which can be performed, and each are described below:

### UNCONSOLIDATED-UNDRAINED TRIAXIAL TEST METHOD

The strength and stress-strain relationships of a cylindrical soil sample are determined for a sample subjected to a selected confining fluid pressure in a triaxial chamber. No drainage of the sample is permitted during the test and the sample is sheared in compression at a constant rate of axial deformation. The peak stress measured for the sample is recorded, up to a maximum 15 percent strain. At least three triaxial tests are performed at various confining fluid pressures to model in-situ stress conditions for loading. A plot of the Mohr circles at failure stress for each confining pressure is included in Appendix A.

### CONSOLIDATED-DRAINED TRIAXIAL TEST METHOD

The strength and stress-strain relationships of a cylindrical soil sample are determined for a sample subjected to a selected confining fluid pressure in a triaxial chamber. The sample is isotropically consolidated prior to applying axial loads and sheared in compression at a slow constant rate of axial deformation while allowing the sample to drain. The peak stress measured for the sample is recorded, up to a maximum 15 percent strain. At least three triaxial tests are performed at various confining fluid pressures to model in-situ stress conditions for loading. A plot of the Mohr circles at failure stress for each confining pressure is included in Appendix A.

### CONSOLIDATED-UNDRAINED TRIAXIAL TEST METHOD

The strength and stress-strain relationships of a cylindrical soil sample are determined for a sample subjected to a selected confining fluid pressure in a triaxial chamber. The sample is isotropically consolidated prior to applying axial loads and sheared undrained in compression at a constant rate of axial deformation. Pore water pressure measurements can also be measured during the shearing of the sample. The peak stress measured for the sample is recorded, up to a maximum 15 percent strain. At least three triaxial tests are performed at various confining fluid pressures to model in-situ stress conditions for loading. A plot of the Mohr circles at failure stress for each confining pressure is included in Appendix A.

## DENSITY TESTS ON ROCK CORES

Density tests involve trimming the ends of an intact rock core sample perpendicular to the length of the sample and measuring the length and diameter. The sample is then weighed, and the weight is divided by the volume to calculate the density.

## UNCONFINED COMPRESSIVE STRENGTH TESTS ON ROCK CORES

Unconfined compression tests were performed to estimate the compressive strength of selected rock core samples. Representative rock cores were selected and cut perpendicular to the length of the sample on both ends to a specified length with a wet saw. In the unconfined compression test, the unconfined compressive strength of a rock core sample is determined by axially loading the rock core sample at a slow, constant rate of strain. The unconfined compressive strength is the maximum compressive stress in the rock core sample, or the load applied when a predetermined amount of strain is achieved.



*Passionate People Building  
and Revitalizing our World*



**ATTACHMENT B**  
**GENERAL DECLARATIONS**

City of Ann Arbor  
Guy C. Larcom Municipal Building  
Ann Arbor, Michigan 48107

Ladies and Gentlemen:

The undersigned, as Bidder, declares that this Bid is made in good faith, without fraud or collusion with any person or persons bidding on the same Contract; that this Bidder has carefully read and examined the bid documents, including City Nondiscrimination requirements and Declaration of Compliance Form, Living Wage requirements and Declaration of Compliance Form, Prevailing Wage requirements and Declaration of Compliance Form, Vendor Conflict of Interest Form, Notice of Pre-Bid Conference, General Information, Bid, Bid Forms, Contract, Bond Forms, General Conditions, Standard Specifications, Detailed Specifications, all Addenda, and the Plans (if applicable) and understands them. The Bidder declares that it conducted a full investigation at the site and of the work proposed and is fully informed as to the nature of the work and the conditions relating to the work's performance. The Bidder also declares that it has extensive experience in successfully completing projects similar to this one.

The Bidder acknowledges that it has not received or relied upon any representations or warrants of any nature whatsoever from the City of Ann Arbor, its agents or employees, and that this Bid is based solely upon the Bidder's own independent business judgment.

The undersigned proposes to perform all work shown on the plans or described in the bid documents, including any addenda issued, and to furnish all necessary machinery, tools, apparatus, and other means of construction to do all the work, furnish all the materials, and complete the work in strict accordance with all terms of the Contract of which this Bid is one part.

In accordance with these bid documents, and Addenda numbered \_\_\_\_\_, the undersigned, as Bidder, proposes to perform at the sites in and/or around Ann Arbor, Michigan, all the work included herein for the amounts set forth in the Bid Forms.

The Bidder declares that it has become fully familiar with the liquidated damage clauses for completion times and for compliance with City Code Chapter 112, understands and agrees that the liquidated damages are for the non-quantifiable aspects of non-compliance and do not cover actual damages that may be shown and agrees that if awarded the Contract, all liquidated damage clauses form part of the Contract.

The Bidder declares that it has become fully familiar with the provisions of Chapter 14, Section 1:320 (Prevailing wages) and Chapter 23 (Living Wage) of the Code of the City of Ann Arbor and that it understands and agrees to comply, to the extent applicable to employees providing services to the City under this Contract, with the wage and reporting requirements stated in the City Code provisions cited. Bidder certifies that the statements contained in the City Prevailing Wage and Living Wage Declaration of Compliance Forms are true and correct. Bidder further agrees that the cited provisions of Chapter 14 and Chapter 23 form a part of this Contract.

The Bidder declares that it has become familiar with the City Conflict of Interest Disclosure Form and certifies that the statement contained therein is true and correct.

The Bidder encloses a certified check or Bid Bond in the amount of 5% of the total of the Bid Price. The Bidder agrees both to contract for the work and to furnish the necessary Bonds and insurance documentation within 10 days after being notified of the acceptance of the Bid.

If this Bid is accepted by the City and the Bidder fails to contract and furnish the required Bonds and insurance documentation within 10 days after being notified of the acceptance of this Bid, then the Bidder shall be considered to have abandoned the Contract and the certified check or Bid Bond accompanying this Bid shall become due and payable to the City.

If the Bidder enters into the Contract in accordance with this Bid, or if this Bid is rejected, then the accompanying check or Bid Bond shall be returned to the Bidder.

In submitting this Bid, it is understood that the right is reserved by the City to accept any Bid, to reject any or all Bids, to waive irregularities and/or informalities in any Bid, and to make the award in any manner the City believes to be in its best interest.

SIGNED THIS \_\_\_\_\_ DAY OF \_\_\_\_\_, 202\_.

\_\_\_\_\_  
Bidder's Name

\_\_\_\_\_  
Authorized Signature of Bidder

\_\_\_\_\_  
Official Address

\_\_\_\_\_  
(Print Name of Signer Above)

\_\_\_\_\_  
Telephone Number

\_\_\_\_\_  
Email Address for Award Notice

**ATTACHMENT C**  
**LEGAL STATUS OF BIDDER**

(The bidder shall fill out the appropriate form and strike out the other three.)

Bidder declares that it is:

\* A corporation organized and doing business under the laws of the State of \_\_\_\_\_, for whom \_\_\_\_\_, bearing the office title of \_\_\_\_\_, whose signature is affixed to this Bid, is authorized to execute contracts.

**NOTE: If not incorporated in Michigan, please attach the corporation's Certificate of Authority**

• A limited liability company doing business under the laws of the State of \_\_\_\_\_, whom \_\_\_\_\_ bearing the title of \_\_\_\_\_ whose signature is affixed to this proposal, is authorized to execute contract on behalf of the LLC.

\* A partnership, organized under the laws of the state of \_\_\_\_\_ and filed in the county of \_\_\_\_\_, whose members are (list all members and the street and mailing address of each) (attach separate sheet if necessary):

---

---

---

---

---

\* An individual, whose signature with address, is affixed to this Bid: \_\_\_\_\_  
(initial here)

**Authorized Official**

\_\_\_\_\_ **Date** \_\_\_\_\_, 202\_

(Print) Name \_\_\_\_\_ Title \_\_\_\_\_

Company:

---

Address:

---

Contact Phone ( ) \_\_\_\_\_ Fax ( ) \_\_\_\_\_

Email \_\_\_\_\_



## ATTACHMENT E

### LIVING WAGE ORDINANCE DECLARATION OF COMPLIANCE

The Ann Arbor Living Wage Ordinance (Section 1:811-1:821 of Chapter 23 of Title I of the Code) requires that an employer who is (a) a contractor providing services to or for the City for a value greater than \$10,000 for any twelve-month contract term, or (b) a recipient of federal, state, or local grant funding administered by the City for a value greater than \$10,000, or (c) a recipient of financial assistance awarded by the City for a value greater than \$10,000, shall pay its employees a prescribed minimum level of compensation (i.e., Living Wage) for the time those employees perform work on the contract or in connection with the grant or financial assistance. The Living Wage must be paid to these employees for the length of the contract/program.

*Companies employing fewer than 5 persons and non-profits employing fewer than 10 persons are exempt from compliance with the Living Wage Ordinance. If this exemption applies to your company/non-profit agency please check here  No. of employees\_\_*

The Contractor or Grantee agrees:

- (a) To pay each of its employees whose wage level is not required to comply with federal, state or local prevailing wage law, for work covered or funded by a contract with or grant from the City, no less than the Living Wage. The current Living Wage is defined as \$16.43/hour for those employers that provide employee health care (as defined in the Ordinance at Section 1:815 Sec. 1 (a)), or no less than \$18.32/hour for those employers that do not provide health care. The Contractor or Grantor understands that the Living Wage is adjusted and established annually on April 30 in accordance with the Ordinance and covered employers shall be required to pay the adjusted amount thereafter to be in compliance with Section 1:815(3).

**Check the applicable box below which applies to your workforce**

- Employees who are assigned to any covered City contract/grant will be paid at or above the applicable living wage without health benefits
- Employees who are assigned to any covered City contract/grant will be paid at or above the applicable living wage with health benefits

- (b) To post a notice approved by the City regarding the applicability of the Living Wage Ordinance in every work place or other location in which employees or other persons contracting for employment are working.
- (c) To provide to the City payroll records or other documentation within ten (10) business days from the receipt of a request by the City.
- (d) To permit access to work sites to City representatives for the purposes of monitoring compliance, and investigating complaints or non-compliance.
- (e) To take no action that would reduce the compensation, wages, fringe benefits, or leave available to any employee covered by the Living Wage Ordinance or any person contracted for employment and covered by the Living Wage Ordinance in order to pay the living wage required by the Living Wage Ordinance.

The undersigned states that he/she has the requisite authority to act on behalf of his/her employer in these matters and has offered to provide the services or agrees to accept financial assistance in accordance with the terms of the Living Wage Ordinance. The undersigned certifies that he/she has read and is familiar with the terms of the Living Wage Ordinance, obligates the Employer/Grantee to those terms and acknowledges that if his/her employer is found to be in violation of Ordinance it may be subject to civil penalties and termination of the awarded contract or grant of financial assistance.

\_\_\_\_\_  
Company Name

\_\_\_\_\_  
Street Address

\_\_\_\_\_  
Signature of Authorized Representative

\_\_\_\_\_  
Date

\_\_\_\_\_  
City, State, Zip

\_\_\_\_\_  
Print Name and Title

\_\_\_\_\_  
Phone/Email address



## Attachment F

# CITY OF ANN ARBOR LIVING WAGE ORDINANCE

RATE EFFECTIVE APRIL 30, 2024 - ENDING APRIL 29, 2025

**\$16.43** per hour

If the employer provides health care benefits\*

**\$18.32** per hour

If the employer does **NOT** provide health care benefits\*

Employers providing services to or for the City of Ann Arbor or recipients of grants or financial assistance from the City of Ann Arbor for a value of more than \$10,000 in a twelve-month period of time must pay those employees performing work on a City of Ann Arbor contract or grant, the above living wage.

## **ENFORCEMENT**

The City of Ann Arbor may recover back wages either administratively or through court action for the employees that have been underpaid in violation of the law. Persons denied payment of the living wage have the right to bring a civil action for damages in addition to any action taken by the City.

Violation of this Ordinance is punishable by fines of not more than \$500/violation plus costs, with each day being considered a separate violation. Additionally, the City of Ann Arbor has the right to modify, terminate, cancel or suspend a contract in the event of a violation of the Ordinance.

\* Health Care benefits include those paid for by the employer or making an employer contribution toward the purchase of health care. The employee contribution must not exceed \$.50 an hour for an average work week; and the employer cost or contribution must equal no less than \$1/hr for the average work week.

**The Law Requires Employers to Display This Poster Where Employees Can Readily See It.**

**For Additional Information or to File a Complaint contact  
Colin Spencer at 734/794-6500 or [cspencer@a2gov.org](mailto:cspencer@a2gov.org)**



**ATTACHEMENT G**

<b>Vendor Conflict of Interest Disclosure Form</b>
--

All vendors interested in conducting business with the City of Ann Arbor must complete and return the Vendor Conflict of Interest Disclosure Form in order to be eligible to be awarded a contract. Please note that all vendors are subject to comply with the City of Ann Arbor’s conflict of interest policies as stated within the certification section below.

If a vendor has a relationship with a City of Ann Arbor official or employee, an immediate family member of a City of Ann Arbor official or employee, the vendor shall disclose the information required below.

1. No City official or employee or City employee’s immediate family member has an ownership interest in vendor’s company or is deriving personal financial gain from this contract.
2. No retired or separated City official or employee who has been retired or separated from the City for less than one (1) year has an ownership interest in vendor’s Company.
3. No City employee is contemporaneously employed or prospectively to be employed with the vendor.
4. Vendor hereby declares it has not and will not provide gifts or hospitality of any dollar value or any other gratuities to any City employee or elected official to obtain or maintain a contract.
5. Please note any exceptions below:

<b>Conflict of Interest Disclosure*</b>	
Name of City of Ann Arbor employees, elected officials or immediate family members with whom there may be a potential conflict of interest.	<input type="checkbox"/> Relationship to employee <hr/> <input type="checkbox"/> Interest in vendor’s company <input type="checkbox"/> Other (please describe in box below)

\*Disclosing a potential conflict of interest does not disqualify vendors. In the event vendors do not disclose potential conflicts of interest and they are detected by the City, vendor will be exempt from doing business with the City.

<b>I certify that this Conflict of Interest Disclosure has been examined by me and that its contents are true and correct to my knowledge and belief and I have the authority to so certify on behalf of the Vendor by my signature below:</b>		
<b>Vendor Name</b>	<b>Vendor Phone Number</b>	
<b>Signature of Vendor Authorized Representative</b>	<b>Date</b>	<b>Printed Name of Vendor Authorized Representative</b>

**ATTACHMENT H****DECLARATION OF COMPLIANCE****Non-Discrimination Ordinance**

The “non discrimination by city contractors” provision of the City of Ann Arbor Non-Discrimination Ordinance (Ann Arbor City Code Chapter 112, Section 9:158) requires all contractors proposing to do business with the City to treat employees in a manner which provides equal employment opportunity and does not discriminate against any of their employees, any City employee working with them, or any applicant for employment on the basis of actual or perceived age, arrest record, color, disability, educational association, familial status, family responsibilities, gender expression, gender identity, genetic information, height, HIV status, marital status, national origin, political beliefs, race, religion, sex, sexual orientation, source of income, veteran status, victim of domestic violence or stalking, or weight. It also requires that the contractors include a similar provision in all subcontracts that they execute for City work or programs.

In addition the City Non-Discrimination Ordinance requires that all contractors proposing to do business with the City of Ann Arbor must satisfy the contract compliance administrative policy adopted by the City Administrator. A copy of that policy may be obtained from the Purchasing Manager

The Contractor agrees:

- (a) To comply with the terms of the City of Ann Arbor’s Non-Discrimination Ordinance and contract compliance administrative policy, including but not limited to an acceptable affirmative action program if applicable.
- (b) To post the City of Ann Arbor’s Non-Discrimination Ordinance Notice in every work place or other location in which employees or other persons are contracted to provide services under a contract with the City.
- (c) To provide documentation within the specified time frame in connection with any workforce verification, compliance review or complaint investigation.
- (d) To permit access to employees and work sites to City representatives for the purposes of monitoring compliance, or investigating complaints of non-compliance.

The undersigned states that he/she has the requisite authority to act on behalf of his/her employer in these matters and has offered to provide the services in accordance with the terms of the Ann Arbor Non-Discrimination Ordinance. The undersigned certifies that he/she has read and is familiar with the terms of the Non-Discrimination Ordinance, obligates the Contractor to those terms and acknowledges that if his/her employer is found to be in violation of Ordinance it may be subject to civil penalties and termination of the awarded contract.

---

Company Name

---

Signature of Authorized Representative

---

Date

---

Print Name and Title

---

Address, City, State, Zip

---

Phone/Email Address

**Questions about the Notice or the City Administrative Policy, Please contact:**

Procurement Office of the City of Ann Arbor  
(734) 794-6500

# ATTACHMENT I

## CITY OF ANN ARBOR NON-DISCRIMINATION ORDINANCE

Relevant provisions of Chapter 112, Nondiscrimination, of the Ann Arbor City Code are included below.  
You can review the entire ordinance at [www.a2gov.org/humanrights](http://www.a2gov.org/humanrights).

**Intent:** It is the intent of the city that no individual be denied equal protection of the laws; nor shall any individual be denied the enjoyment of his or her civil or political rights or be discriminated against because of actual or perceived age, arrest record, color, disability, educational association, familial status, family responsibilities, gender expression, gender identity, genetic information, height, HIV status, marital status, national origin, political beliefs, race, religion, sex, sexual orientation, source of income, veteran status, victim of domestic violence or stalking, or weight.

**Discriminatory Employment Practices:** No person shall discriminate in the hire, employment, compensation, work classifications, conditions or terms, promotion or demotion, or termination of employment of any individual. No person shall discriminate in limiting membership, conditions of membership or termination of membership in any labor union or apprenticeship program.

**Discriminatory Effects:** No person shall adopt, enforce or employ any policy or requirement which has the effect of creating unequal opportunities according to actual or perceived age, arrest record, color, disability, educational association, familial status, family responsibilities, gender expression, gender identity, genetic information, height, HIV status, marital status, national origin, political beliefs, race, religion, sex, sexual orientation, source of income, veteran status, victim of domestic violence or stalking, or weight for an individual to obtain housing, employment or public accommodation, except for a bona fide business necessity. Such a necessity does not arise due to a mere inconvenience or because of suspected objection to such a person by neighbors, customers or other persons.

**Nondiscrimination by City Contractors:** All contractors proposing to do business with the City of Ann Arbor shall satisfy the contract compliance administrative policy adopted by the City Administrator in accordance with the guidelines of this section. All city contractors shall ensure that applicants are employed and that employees are treated during employment in a manner which provides equal employment opportunity and tends to eliminate inequality based upon any classification protected by this chapter. All contractors shall agree not to discriminate against an employee or applicant for employment with respect to hire, tenure, terms, conditions, or privileges of employment, or a matter directly or indirectly related to employment, because of any applicable protected classification. All contractors shall be required to post a copy of Ann Arbor's Non-Discrimination Ordinance at all work locations where its employees provide services under a contract with the city.

**Complaint Procedure:** If any individual believes there has been a violation of this chapter, he/she may file a complaint with the City's Human Rights Commission. The complaint must be filed within 180 calendar days from the date of the individual's knowledge of the allegedly discriminatory action or 180 calendar days from the date when the individual should have known of the allegedly discriminatory action. A complaint that is not filed within this timeframe cannot be considered by the Human Rights Commission. To file a complaint, first complete the complaint form, which is available at [www.a2gov.org/humanrights](http://www.a2gov.org/humanrights). Then submit it to the Human Rights Commission by e-mail ([hrc@a2gov.org](mailto:hrc@a2gov.org)), by mail (Ann Arbor Human Rights Commission, PO Box 8647, Ann Arbor, MI 48107), or in person (City Clerk's Office). For further information, please call the commission at 734-794-6141 or e-mail the commission at [hrc@a2gov.org](mailto:hrc@a2gov.org).

**Private Actions For Damages or Injunctive Relief:** To the extent allowed by law, an individual who is the victim of discriminatory action in violation of this chapter may bring a civil action for appropriate injunctive relief or damages or both against the person(s) who acted in violation of this chapter.

THIS IS AN OFFICIAL GOVERNMENT NOTICE AND  
MUST BE DISPLAYED WHERE EMPLOYEES CAN READILY SEE IT.

## MICHIGAN DEPARTMENT OF TRANSPORTATION CERTIFIED PAYROLL

COMPLETION OF CERTIFIED PAYROLL FORM FULFILLS THE MINIMUM MDOT PREVAILING WAGE REQUIREMENTS

(1) NAME OF CONTRACTOR / SUBCONTRACTOR (CIRCLE ONE) (2) ADDRESS

(3) PAYROLL NO. (4) FOR WEEK ENDING (5) PROJECT AND LOCATION (6) CONTRACT ID

(a) EMPLOYEE INFORMATION	(b) WORK CLASSIFICATION	(c) Hour Type	(d) DAY AND DATE							(e) TOTAL HOURS ON PROJECT	(f) PROJECT RATE OF PAY	(g) PROJECT RATE OF FRINGE PAY	(h) GROSS PROJECT EARNED		(i) TOTAL WEEKLY HOURS WORKED ALL JOBS	(j) DEDUCTIONS						(k) TOTAL WEEKLY WAGES PAID FOR ALL JOBS
														GROSS PROJECT EARNED		GROSS WEEKLY EARNED	FICA	FEDERAL	STATE	OTHER	TOTAL DEDUCT	
NAME:									0				\$0.00								\$0.00	\$0.00
ETH#GEN: ID #:	GROUP/CLASS #:	S							0				\$0.00								\$0.00	\$0.00
NAME:									0				\$0.00								\$0.00	\$0.00
ETH#GEN: ID #:	GROUP/CLASS #:	S							0				\$0.00								\$0.00	\$0.00
NAME:									0				\$0.00								\$0.00	\$0.00
ETH#GEN: ID #:	GROUP/CLASS #:	S							0				\$0.00								\$0.00	\$0.00
NAME:									0				\$0.00								\$0.00	\$0.00
ETH#GEN: ID #:	GROUP/CLASS #:	S							0				\$0.00								\$0.00	\$0.00
NAME:									0				\$0.00								\$0.00	\$0.00
ETH#GEN: ID #:	GROUP/CLASS #:	S							0				\$0.00								\$0.00	\$0.00
NAME:									0				\$0.00								\$0.00	\$0.00
ETH#GEN: ID #:	GROUP/CLASS #:	S							0				\$0.00								\$0.00	\$0.00
NAME:									0				\$0.00								\$0.00	\$0.00

Date \_\_\_\_\_

I, \_\_\_\_\_ (Name of Signatory Party) \_\_\_\_\_ (Title)

do hereby state:

(1) That I pay or supervise the payment of the persons employed by

\_\_\_\_\_ on the \_\_\_\_\_  
 (Contractor or Subcontractor)  
 \_\_\_\_\_; that during the payroll period commencing on the \_\_\_\_\_  
 (Building or Work)  
 \_\_\_\_\_ day of \_\_\_\_\_, \_\_\_\_\_, and ending the \_\_\_\_\_ day of \_\_\_\_\_, \_\_\_\_\_,  
 all persons employed on said project have been paid the full weekly wages earned, that no rebates have been or will be made either directly or indirectly to or on behalf of said

\_\_\_\_\_ from the full  
 (Contractor or Subcontractor)

weekly wages earned by any person and that no deductions have been made either directly or indirectly from the full wages earned by any person, other than permissible deductions as defined in Regulations, Part 3 (29 C.F.R. Subtitle A), issued by the Secretary of Labor under the Copeland Act, as amended (48 Stat. 948, 63 Stat. 108, 72 Stat. 967; 76 Stat. 357; 40 U.S.C. § 3145), and described below:

\_\_\_\_\_  
 \_\_\_\_\_  
 \_\_\_\_\_  
 \_\_\_\_\_

(2) That any payrolls otherwise under this contract required to be submitted for the above period are correct and complete; that the wage rates for laborers or mechanics contained therein are not less than the applicable wage rates contained in any wage determination incorporated into the contract; that the classifications set forth therein for each laborer or mechanic conform with the work he performed.

(3) That any apprentices employed in the above period are duly registered in a bona fide apprenticeship program registered with a State apprenticeship agency recognized by the Bureau of Apprenticeship and Training, United States Department of Labor, or if no such recognized agency exists in a State, are registered with the Bureau of Apprenticeship and Training, United States Department of Labor.

(4) That:

(a) WHERE FRINGE BENEFITS ARE PAID TO APPROVED PLANS, FUNDS, OR PROGRAMS

- in addition to the basic hourly wage rates paid to each laborer or mechanic listed in the above referenced payroll, payments of fringe benefits as listed in the contract have been or will be made to appropriate programs for the benefit of such employees, except as noted in section 4(c) below.

(b) WHERE FRINGE BENEFITS ARE PAID IN CASH

- Each laborer or mechanic listed in the above referenced payroll has been paid, as indicated on the payroll, an amount not less than the sum of the applicable basic hourly wage rate plus the amount of the required fringe benefits as listed in the contract, except as noted in section 4(c) below.

(c) EXCEPTIONS

EXCEPTION (CRAFT)	EXPLANATION

REMARKS:  
 \_\_\_\_\_  
 \_\_\_\_\_  
 \_\_\_\_\_  
 \_\_\_\_\_  
 \_\_\_\_\_

NAME AND TITLE	SIGNATURE
THE WILLFUL FALSIFICATION OF ANY OF THE ABOVE STATEMENTS MAY SUBJECT THE CONTRACTOR OR SUBCONTRACTOR TO CIVIL OR CRIMINAL PROSECUTION. SEE SECTION 1001 OF TITLE 18 AND SECTION 231 OF TITLE 31 OF THE UNITED STATES CODE.	