

ADDENDUM No. 1

RFP No. 24-51

Leslie Park and Sylvan Park Bridge Replacements

Due: October 1, 2024 at 3:00 PM (local time)

The information contained herein shall take precedence over the original documents and all previous addenda (if any), and is appended thereto. **This Addendum includes four (4) pages, fifty (50) pages of attachments, and Addendum #1 drawings with ten (10) pages.**

The Proposer is to acknowledge receipt of this Addendum No. 1, including all attachments in its Proposal by so indicating in the proposal that the addendum has been received. Proposals submitted without acknowledgement of receipt of this addendum may be considered non-conforming.

The following forms provided within the RFP Document should be included in submitted proposal:

- Attachment B – General Declarations
- Attachment D – Prevailing Wage Declaration of Compliance
- Attachment E – Living Wage Declaration of Compliance
- Attachment G – Vendor Conflict of Interest Disclosure Form
- Attachment H – Non-Discrimination Declaration of Compliance

Proposals that fail to provide these completed forms listed above upon proposal opening may be rejected as non-responsive and may not be considered for award.

I. CORRECTIONS/ADDITIONS/DELETIONS

Changes to the RFP documents which are outlined below are referenced to a page or Section in which they appear conspicuously. Offerors are to take note in its review of the documents and include these changes as they may affect work or details in other areas not specifically referenced here.

Section/Page(s)	Change
Drawing C-100	Added grading limits.
Drawings C-101 and C-102	Changed in its entirety per Contech's request.
Drawing C-103	Added callout to Section A-A
Drawing C-104	Added grading limits. The east-side of Sylvan Bridge is shown as being replaced with Sidwalk, Conc, 4 inch and quantity has been adjusted.
Drawing C-105	Added callout to Section A-A and Section B-B
Drawing C-200	Added sheet to provide staging plan.

Detailed Specifications, Section A – Replace with the following:
PREFABRICATED BRIDGE, **Uniform Live Load.** ...The superstructure shall be designed for
CONCRETE DECK a maintenance vehicle satisfying the AASHTO **H-5** Design Truck
22 FEET, SYLVAN PARK configuration....

Detailed Specifications Specifications have been included for “Steel Structure, Cleaning and Coating, Partial, Special” and “Timber Decking and Composite Handrail.”

Section E. Schedule of Pricing/Cost Item number 8030044 - Sidewalk, Conc, 4 inch quantity has been revised to 150 sft.

Article III – Time of Completion Revised as: “...Sylvan Park shall be completed within two hundred forty (240) calendar days...”

II. QUESTIONS AND ANSWERS

The following Questions have been received by the City. Responses are being provided in accordance with the terms of the RFP. Respondents are directed to take note in its review of the documents of the following questions and City responses as they affect work or details in other areas not specifically referenced here.

Question 1: SESC – MDOT Item No 2080036 Erosion Control, Silt Fence shows a quantity of 500 ft, but a drawing/layout is not provided in the bid documents to account for this footage? Please provide a layout.

- a. Is there any preliminary SESC permit submitted etc for this project, or does the contractor have to provide to the City SESC permit department?
- b. If the contractor is required to install more than 500 In ft will the contractor be compensated?

Answer 1: Erosion Control, Silt Fence shall be placed at the grading limits (added to the plans for clarification) of the project. The Contractor is responsible for obtaining a SESC permit from the City of Ann Arbor. Any silt fence installed over the estimated quantity of 500 feet will be compensated.

Question 2: Are there designated lay down and material staging areas for both bridge sites? Can a layout be provided showing such?

Answer 2: Drawing C-200 has been added to the plans showing designated staging areas for both bridge sites.

Question 3: Any density, concrete testing required and who is providing the services?

Answer 3: Yes, density and concrete testing is required per MDOT Standard Specifications for Construction and shall be provided by the Contractor.

Question 4: “Attachment C – Legal Status of Bidder” is not listed in the required attachments section, but this form is usually required with a lot of other bids we have submitted. Is this also supposed to be included?

Answer 4: Ideally Attachment C – Legal Status of Bidder should be included but it being missed and not included in any submittal is not grounds for automatic rejection as non-responsive. Note the language on Page 16 under G. Attachments that outlines that many of the forms included in the RFP Document “should be completed and returned with the proposal.” Further, note the language on Page 5 that states that “*Proposals that fail to provide these forms listed above upon proposal opening may be deemed non-responsive and may not be considered for award.*”

- Question 5: Sylvan Park. The structure is listed as 8 ft wide, which is fine. However, the SP notes the bridges need to be designed to a H-10 vehicle load. An 8 ft wide structure would be designed to a H-5 – the county maintenance vehicles wouldn't exceed that amount. The other structure is 12 ft wide, and would be designed for the H-10 load.
- Answer 5: The detailed specification for Prefabricated Bridge, Concrete Deck, 22 feet, Sylvan Park has been updated to state that it shall be designed to H-5 vehicle load.
- Question 6: Based on our understanding the superstructure for the bridge to be installed at the Leslie Park location was salvaged from another location and is currently in the possession of the City of Ann Arbor. Within the plans and specifications, it states that this structure will need to be refurbished.
- Who is responsible to perform the refurbishment of this structure?
 - If the contractor is responsible, please provide a specific scope and the appropriate details for the refurbishment of the structure – currently in the plans are the shop drawings of the bridge from the original installation and does not call out what components to be refurbished.
- Answer 6: The Contractor is responsible for refurbishment of the salvaged structure. The scope of work includes providing and installing new stringers and nailers; cleaning, coating and painting approximately 470 sft of structural steel including the floor beams and bracing diagonals; and providing and installing timber decking. Specifications have been included for "Steel Structure, Cleaning and Coating, Partial, Special" and "Timber Decking and Composite Handrail." This work shall be included in the pay item "_Prefabricated Bridge, Timber Deck, 30 feet, Leslie Park."
- Question 7: Has there been any geotechnical work performed at these bridge locations? If so, please provide the geotechnical report.
- Answer 7: Yes, please see attached.
- Question 8: The work will impact the existing waterways – will the contractor be subject to any work in water restrictions or other permit restrictions? If there are any permits available, please provide the permits for our review.
- Answer 8: Yes, please see attached EGLE permits.
- Question 9: Per Article III – Time of Completion, the Sylvan Park location must be completed within 145 days of notice to proceed. Based on recent projects with prefabricated bridges, the design/shop drawing preparation time is approximately 6 weeks, assuming an owner review of shops of 3 weeks (with no re-submittal) and a fabrication time of approximately 24 weeks. This time frame puts us well over the 145 days allowed – please consider revising the time of completion to allow for the fabrication and delivery of the bridge.
- Answer 9: Article III – Time of Completion has been revised to state that Sylvan Park shall be completed within 240 days to accommodate fabrication and delivery of the bridge.
- Question 10: The Leslie Park bridge location appears to be part of a golf course. Are there any work restrictions related to this location being within a golf course?
- Answer 10: Yes, work at Leslie Park will need to be completed before golf season resumes (April 2025). Follow MDOT Standard Specifications for Construction Section 706 for any foundation construction in winter months.
- Question 11: The plans appear to depict an aggregate surface course for the path on the east side of the bridge at the Sylvan Park location. Where is payment for the restoration of the path on this side of the bridge to be made?
- Answer 11: Drawing C-104 has been revised to show the east side of Sylvan Park bridge being replaced with sidewalk, paid for as Sidewalk, Conc, 4 inch. The quantity for this item has been increased to 150 sft.

Question 12: For both structures, how is Foundation Exc, 6A Stone (mud mat), and cofferdams paid?

Answer 12: On Drawings C-100 and C-104, Keynote 3 specify that excavation, dewatering, and site preparation shall be included in pay item, Substructure Conc.

Offerors are responsible for any conclusions that they may draw from the information contained in the Addendum.

E. Schedule of Pricing/Cost – 20 Points

Company: _____

Unit Price Bid –

MDOT Item No.	Item Description	Estimated Quantity	Unit Price	Total Price
1100001	Mobilization, Max 10%	1 LSUM	\$	\$
2040055	Sidewalk, Rem	15 SYD	\$	\$
2040060	Structures, Rem (Leslie Bridge)	1 LSUM	\$	\$
2040060	Structures, Rem (Sylvan Bridge)	1 LSUM	\$	\$
2050012	Embankment, Structure, CIP	152 CYD	\$	\$
2060005	Aggregate (6A)	11 CYD	\$	\$
2080036	Erosion Control, Silt Fence	500 FT	\$	\$
2090001	Project Cleanup	1 LSUM	\$	\$
2097051	_Audio Visual File, Special	1 LSUM	\$	\$
4040001	Underdrain, Bank, 4 inch	90 FT	\$	\$
4040111	Underdrain, Outlet Ending, 4 inch, with Rodent Screen	8 EA	\$	\$
5010005	HMA Surface, Rem	30 SYD	\$	\$
7060100	Substructure Conc	92 CYD	\$	\$
7077051	_Prefabricated Bridge, Timber Deck, 30 feet, Leslie Park	1 LSUM	\$	\$
7077051	_Prefabricated Bridge, Conc Deck, 22 feet, Sylvan Park	1 LSUM	\$	\$
8030044	Sidewalk, Conc, 4 inch	150 SFT	\$	\$
8030046	Sidewalk, Conc, 6 inch	250 SFT	\$	\$
8080007	Fence, Protective	100 FT	\$	\$
8130012	Riprap, Plain, LM	38 CYD	\$	\$
8120026	Pedestrian Type II Barricade, Temp	4 EA	\$	\$
8167011	_Turf Establishment, Performance	250 SYD	\$	\$

ESTIMATED TOTAL \$ _____

the Supervising Professional is: **Hillary Hanzel** whose job title is **Landscape Architect IV**. If there is any question concerning who the Supervising Professional is, Contractor shall confirm with the manager of the Administering Service Area/Unit.

Contractor's Representative means _____ **[Insert name]** whose job title is **[Insert job title]**.

ARTICLE III - Time of Completion

- (A) The work to be completed under this Contract shall begin immediately on the date specified in the Notice to Proceed issued by the City.
- (B) The entire work for this Contract at Leslie Park shall be completed within one hundred five (105) consecutive calendar days and **the entire work for this Contract at Sylvan Park shall be completed within two hundred forty (240) calendar days.**
- (C) Failure to complete all the work within the time specified above, including any extension granted in writing by the Supervising Professional, shall obligate the Contractor to pay the City, as liquidated damages and not as a penalty, an amount equal to \$500 for each calendar day of delay in the completion of all the work. If any liquidated damages are unpaid by the Contractor, the City shall be entitled to deduct these unpaid liquidated damages from the monies due the Contractor. The liquidated damages are for the non-quantifiable aspects of any of the previously identified events and do not cover actual damages that can be shown or quantified nor are they intended to preclude recovery of actual damages in addition to the recovery of liquidated damages.

ARTICLE IV - The Contract Sum

- (A) The City shall pay to the Contractor for the performance of the Contract, the unit prices as given in the Bid Form for the estimated bid total of:
_____ Dollars (\$_____)
- (B) The amount paid shall be equitably adjusted to cover changes in the work ordered by the Supervising Professional but not required by the Contract Documents. Increases or decreases shall be determined only by written agreement between the City and Contractor.

ARTICLE V - Assignment

This Contract may not be assigned or subcontracted any portion of any right or obligation under this contract without the written consent of the City. Notwithstanding any consent by the City to any assignment, Contractor shall at all times remain bound to all warranties, certifications, indemnifications, promises and performances, however described, as are required of it under this contract unless specifically released from the requirement, in writing, by the City.

CITY OF ANN ARBOR
DETAILED SPECIFICATION
FOR
STEEL STRUCTURE, CLEANING, PARTIAL, SPECIAL
STEEL STRUCTURE, COATING, PARTIAL, SPECIAL

DLZ: MTL

Page 1 of 2

10/01/19

Description.

This work consists of cleaning and coating all structural steel floor beams (Wide Flange and HSS members) at the Bandemer Park Vehicle and Pedestrian Truss Superstructures; all structural steel floor beams and fascia stringers (HSS members) at the Mitchell Field Pedestrian Truss Superstructure; and, all HSS floor beams, stringers and bracing diagonals at the Argo Park Pedestrian Structure. The entire length and all exposed surfaces of existing floor beams shall be cleaned and coated from face-to-face of the existing trusses. All other members indicated shall be cleaned and coated on all exposed surfaces, from end-to-end of all members. The work shall be completed as described in Section 715 of the 2012 Michigan Department of Transportation (MDOT) Specifications for Construction and modified herein.

Materials.

Coating materials shall be as follows, and all work of this section shall be completed in accordance with Section 715 and the Manufacturers recommendations and specifications for cleaning, coating and curing, and as modified herein:

- 1st Coat: Carbomastic® 615AL (or equal) – 8 mils minimum dry film thickness
- 2nd and 3rd (top) Coats: Carbothane® 134HG (or equal) – 2 mils minimum dry film thickness (each coat)

The color of the top coat shall be dark brown to match the existing trusses. The top coat shall be high-gloss. The AMS-STD-595 color shall be submitted for review by the Engineer prior to coating. The Engineer reserves the right to request revisions to the coating color to ensure compatibility with the surrounding environment.

Coating materials shall be altered, as required by the Manufacturer, to meet cold-weather application and curing conditions present at the structures during this item of work.

Construction.

Conduct all work in accordance with Section 715 of the 2012 MDOT Standard Specifications for Construction except as modified on the drawings and herein. The members to be cleaned and coated are uncoated A588 structural steel. The additional effort to clean the structural steel and the additional coating material required due to excessive surface profile will not be paid for separately but will be considered included in the bid items.

Removal of existing decking and stringers, as noted on the drawings, shall be completed prior to cleaning and coating operations, to allow maximum access, inspection and completeness of this work. Work associated with coating existing members shall be completed and the coating cured prior to placing new stringers. Holes to be drilled in existing members shall be completed, cleaned and coated prior to placing connections and new members.

Surfaces to be coated shall be cleaned to meet Surface Preparation Standard SSPC-SP3 (Power Tool Cleaning). Blast Cleaning will not be allowed. All debris removed during these operations shall be collected and removed off-site in accordance with applicable laws and regulations. All measures utilized by the Contractor to contain debris shall be entirely effective to the satisfaction of the Engineer.

CITY OF ANN ARBOR
DETAILED SPECIFICATION
FOR
STEEL STRUCTURE, CLEANING, PARTIAL, SPECIAL
STEEL STRUCTURE, COATING, PARTIAL, SPECIAL

DLZ: MTL

Page 2 of 2

10/01/19

Section loss of any cleaned member greater than 25% shall be immediately reported to the Engineer in writing. The Engineer shall inspect the area(s) of deterioration and direct the Contractor to make steel repairs, if necessary, prior to coating the area(s).

Coating shall be performed in accordance with Section 715 of the 2012 MDOT Standard Specifications for Construction and as modified on the drawings and herein.

Measurement and Payment.

The completed work, as described, will be measured and paid for at the contract unit price using the following pay item:

<u>Pay Item</u>	<u>Pay Unit</u>
Steel Structure, Cleaning, Partial, Special (Structure Name).....	Lump Sum
Steel Structure, Coating, Partial, Special (Structure Name).....	Lump Sum

Steel Structure, Cleaning, Partial, Special (Structure Name) and **Steel Structure, Coating, Partial, Special (Structure Name)** includes all labor, equipment, and materials necessary to clean and coat the existing structural steel, as indicated on the plans and detailed herein.

The Contractor shall provide for access to cleaning and coating areas for construction inspection and material testing services.

CITY OF ANN ARBOR
DETAILED SPECIFICATION
FOR
TIMBER DECKING AND COMPOSITE HANDRAIL

DLZ: MAK

Page 1 of 2

02/11/22

Description. This work consists of providing all labor, materials, and equipment necessary to construct the timber decking and railings as shown on the drawings; including all timber, composite handrails, hardware, fasteners, and related construction materials as called for on the drawings. Ensure all work is performed in accordance with this Detailed Specification, Section 709 of the Michigan Department of Transportation (MDOT) 2020 Standard Specifications for Construction, Local and State Building Codes, the project plans, and the Americans with Disabilities Act.

Materials. Provide materials in accordance with the following sections in the 2020 MDOT Standard Specifications for Construction:

Miscellaneous Metals.....	908
Hardware.....	908
Structural Timber and Lumber	912

1. Timber Decking and Composite Lumber. All lumber must be dressed S4S (surfaced four sides) in accordance with *ASTM D245*. All lumber sizes are nominal. All exposed edges must be free from splinters and have sharp edges sanded smooth.

A. Timber Decking:

Bandemer Park Pedestrian Truss Superstructure: 3-inch by 12-inch, Southern Pine No. 1 Dense, treated.

Bandemer Park Vehicle Truss Superstructure: 4-inch by 12-inch, Southern Pine No. 1 Dense, treated.

B. Composite Handrail: 2-inch by 8-inch, recycled composite lumber.

C. Wood Preservative. Refer to the Special Provision for Micronized Copper Water-Based Wood Preservative Systems. After treatment, re-dry to 19 percent maximum moisture content prior to shipping.

2. Hardware. Provide all hardware and accessories required to properly and completely execute the carpentry for this project, including, but not limited to: screws, bolts, nuts, washers, hangers, straps, and similar items, whether specifically mentioned herein or not. Nails must not protrude through the backside of any member unless specifically noted in the contract. Bolt heads in and rails and other rails shall be counterbored so as to not protrude above the adjacent surface of the timber rail.

A. Fasteners. Regular hexagon-head or carriage-head hot dipped galvanized ASTM A307 steel bolts, nuts and washers; ASTM A123 for bolts, and ASTM A153 for washers.

B. Screws. Hot dipped galvanized, ASTM A653, batch or post-dipped process, with a minimum coating thickness of 1.85 ounces of Zinc per square foot of surface area (G185), of type and size indicated on the contract plans.

C. Submittals. Product data conforming to the materials listed above.

Construction. Furnish and install all materials in accordance with the plans, this Detailed Specification and Sections 709 and 912 of the Standard Specifications for Construction. Set rough carpentry to required levels and lines, with members plumb, true to line, cut, and fitted. Fit rough carpentry to other construction; scribe and cope as needed for accurate fit.

Framing Standard: Comply with American Wood Council/American Forest & Paper Association (AF&PA's) "Details for Conventional Wood Frame Construction".

Sort and select lumber so that natural characteristics will not interfere with installation or with fastening other materials to lumber. Do not use materials with defects. Lumber with wane will not be allowed to be used for exposed edges of railing or deck materials. Comply with AWPA M4 for applying a field treatment of copper naphthenate to cut surfaces of preservative-treated lumber. Install decking with annular rings downward. Do not install boards with knot holes or defects that will affect the walking surface.

Submit to the Engineer for approval at least 14 calendar days prior to the start of construction the detailed description of the construction procedures proposed for review, including a list of major equipment to be used. Work shall not begin until submittal has been received and approved by the Engineer.

Field Storage and Handling. If products are stored temporarily at the job site after arrival, wood members must be placed on blocking, well off the ground and be separated by wood blocking so air can circulate around each member. Cover wood as directed in Section 709.03.A.

Measurement and Payment. The completed work, as described, will be measured and paid for at the contract price using the following pay items:

<u>Pay Item</u>	<u>Pay Unit</u>
Timber Decking, __ inch by __ inch	Square Foot
Composite Railing, __ inch by __ inch.....	Foot

Payment for **Timber Decking, __ inch by __ inch** and **Composite Railing, __ inch by __ inch** includes all miscellaneous metals and hardware to complete the work described herein. Payment for **Timber Decking, __ inch by __ inch**, shall be measured in-place, after installation. Payment for **Composite Railing, __ inch by __ inch**, shall be measured along the horizontal length of railing, after installation.

CITY OF ANN ARBOR
SPECIAL PROVISION
FOR
PREFABRICATED BRIDGE, CONCRETE DECK, 22 FEET, SYLVAN PARK

STN:CRW

1 of 7

09-19-2024

a. Description. This item shall consist of furnishing the labor, materials and equipment required to design, fabricate, deliver and install a Prefabricated Bridge as shown on the plans and as approved by the Engineer. All work shall be done in accordance with these specifications and accompanying drawings, AASHTO LRFD Guide Specifications for the Design of Pedestrian Bridges 2nd edition, AASHTO LRFD Bridge Design Specifications 7th edition (AASHTO LRFD), Guide for the Development of Bicycle Facilities 4th edition and the Michigan Department of Transportation 2020 Standard Specifications for Construction. All work to be level, true to line and grade in a good quality workmanlike manner. These specifications are based on pre-approved products designed and manufactured by:

Continental Bridge –
8301 State Highway 29 North
Alexandria, MN 56308
(800) 328-2047 or (320) 852-7500 Fax: (320) 852-7067

Excel Bridge Manufacturing –
12001 Shoemaker Ave.
Santa Fe Springs, CA 90670
800-548-0054

All bridge manufacturers shall submit sealed calculations prepared by a licensed Professional Engineer registered in the State of Michigan.

b. Design.

1. Spans: Bridge spans shall be 22'-0" (Sylvan Park) (straight line dimension) and shall be measured from each end of the bridge.
2. Width: The inside clear bridge width shall be 8'-0" (Sylvan Park) and shall be measured from the inside face of structural elements.
3. Railing: The railing height shall be 42 inches. Openings in railing elements shall not be greater than 4".
4. The bridge shall be a Connector Truss of constant depth with square vertical ends.
5. Engineering: Structural design of the bridge structure shall be performed by or under direct supervision who works directly for the Bridge Manufacture. The Engineer shall be a Licensed Professional Engineer licensed in the State of Michigan and done in accordance with AASHTO LRFD design criteria. The Licensed Professional Engineer shall have Professional Liability Insurance with an aggregate policy of \$5,000,000. The certificate shall be submitted with the shop drawings.

A. Uniform Live Load. All structural members of the superstructure shall be designed for a uniform pedestrian live load of 90 psf. The pedestrian live load shall be applied to those areas of the walkway so as to produce maximum stress in the member being designed. The superstructure shall be designed for a maintenance vehicle satisfying the **AASHTO H-5 Design Truck** configuration. A single truck shall be placed to produce the maximum load effects and shall not be placed in combinations with the pedestrian load.

B. Wind Loads. The superstructure shall be designed for a wind load of 35 psf on the full vertical surface area of the front elevation. In addition, a vertical uplift line load caused by a pressure of 0.020 ksf over the full deck width shall be applied at the windward quarter point of the deck.

Wind loads are to be considered fatigue live loading. The fatigue loading used for the fatigue and fracture limit state (Fatigue I) shall be as specified in Section 11 of the current AASHTO Standard Specifications for Structural Supports for Highway Signs, Luminaires, and Traffic Signals. The natural wind gust of that specification need only be considered.

C. Flood Way Loads. The superstructure shall be designed for hydraulic loads in conditions where the bridge cords are within the 100-year floodway elevation. Velocity of 5 feet per second will be used for flood loads.

D. Top Chord Loads. The top chord, truss verticals, and floor beams shall be designed for the lateral wind loads above. In no case shall the load be less than 50 plf or 200 lbs point load, whichever produces greater stresses, applied in any direction at any point along the top chord.

E. Stability. The vertical truss members and the floorbeams and their connections in half through-truss spans shall be proportioned to resist a lateral force of not less than 0.30 klf applied at the top panel points of each truss, considered as a permanent load for the Strength I Load Combination and factored accordingly.

The top chord shall be considered as a column with elastic lateral supports at the panel points.

F. Combinations of Loads. The truss shall be designed for the load combinations and load factors specified in *AASHTO LRFD* Table 3.4.1-1. The load combinations to be examined are: Strength Limit States I & III, Service Limit States I & II, and Fatigue Limit State I. The load factor for Fatigue I load combination shall be taken as 1.0.

G. Deflection. Deflections are to be investigated at the service limit state using load combination Service I in Table 3.4.1-1 of *AASHTO LRFD*. The deflection of the superstructure due to unfactored pedestrian live loading shall not exceed 1/500 of the span length. Horizontal deflections under unfactored wind loading shall not exceed 1/500 of the span length.

H. Minimum Thickness of Metal. The minimum thickness of all structural steel members shall be ¼" nominal and be in accordance with the AISC Manual of Steel Construction's "Standard Mill Practice Guidelines". For ASTM A588 tubing, the



MATERIALS TESTING CONSULTANTS

**REPORT OF GEOTECHNICAL INVESTIGATION
CITY OF ANN ARBOR PEDESTRIAN BRIDGE REPAIRS
ANN ARBOR, MICHIGAN**

Prepared For:

STANTEC

Prepared By:

MATERIALS TESTING CONSULTANTS, INC.

December 2023
MTC Project No. 231294



December 14, 2023
Project No. 231294

Stantec
3754 Ranchero Drive
Ann Arbor, Michigan 48108

Attention: Cassandra Wagner, P.E.

Reference: Report of Geotechnical Investigation
City of Ann Arbor Pedestrian Bridge Repairs
Ann Arbor, Michigan

Dear Ms. Wagner:

We have completed a geotechnical investigation for the above-referenced project. The purpose of this investigation has been to identify the general subsurface soil conditions in the vicinity of the proposed construction, analyze the conditions relative to the planned construction and to provide recommendations for the design of foundations and earth-related structures. This work has been performed as described in our proposal dated March 10, 2023.

Presented herein are descriptions of our understanding of the design considerations, the geotechnical investigation, encountered conditions and engineering recommendations. The Appendix contains the report limitations and boring log terminology, soil classification chart, boring logs and laboratory test data.

DESIGN CONSIDERATIONS

Available Information

We have been provided the following documents and information for use in this investigation:

- Plan drawings of the proposed bridge sections, including general notes and construction details, prepared by Contech Construction Products, Inc. and dated September 8, 2011, provided by Ms. Cassandra Wagner, P.E. of Stantec on October 31, 2023.



- Design loads for the proposed bridges provided by Ms. Cassandra Wagner, P.E. of Stantec on October 31, 2023.
- Design scour levels for the proposed bridges provided by Ms. Cassandra Wagner, P.E. of Stantec on November 27, 2023.
- Telephone and email conversations with Ms. Cassandra Wagner, P.E. of Stantec regarding the type of construction, site access and scope of geotechnical investigation.

Project Description

The project includes replacement of two pedestrian bridges, one in Sylvan Park over the Swift Drain and one at the Leslie Park Golf Course over Traver Creek. The vicinity of the two proposed bridge replacements is shown on the attached Boring Location Plan, Figure Nos. 1 and 2. Sylvan Park is located at address 2600 Yost Boulevard and Leslie Park Golf Course is located at 2120 Traver Road in Ann Arbor, Michigan.

The proposed bridge structures will be the same at each site and will be of steel construction, 12-ft wide and 20-ft long. We understand that the bridges will be placed on shallow spread foundations. The provided scour elevations are 792.5 at Sylvan Park and 826 at Leslie Park Golf Course. We have considered shallow bridge foundations will bear below the provided scour elevations.

We been provided maximum abutment loads of 61.5 and 85.3 kips for service and strength conditions, respectively. Our analysis considers only static soil loading, and dynamic load analysis has not been requested. Traffic on the bridges is expected to consist of pedestrian traffic and light vehicles such as bikes and golf carts.

We should be informed of any changes between the actual design conditions and those described herein as this information may affect our recommendations.



INVESTIGATION METHODOLOGY

Field Investigation

Subsurface conditions near the planned bridge abutments were investigated by 4 conventional soil test borings. Borings B-1 and B-2 were drilled to depths of 60 ft at Sylvan Park and Borings B-3 and B-4 were drilled to depths of 60 ft at Leslie Park Golf Course. Boring locations are shown on the attached plans, Figure Nos. 1 and 2.

MTC staked the approximate boring locations in the field. Boring elevations were approximated by GPS. The elevations used in this report are given in feet and are based on NAVD88 datum, with boring coordinates based on the Michigan State Plane South Coordinate system. If more precise location and elevation data are desired, a registered professional land surveyor should be retained to locate the borings and determine their ground elevations.

The drilling was performed using conventional hollow-stem auger methods to advance the boreholes. The boreholes were backfilled to the original ground surface after drilling completion.

Soil samples were recovered at regular intervals by means of the Standard Penetration Test (SPT), ASTM D1586. The SPT test involves the use of a 140-lb hammer with a 30-inch drop to drive a standard 2.0-inch O.D. split spoon sampler. The number of hammer blows required to drive the sampler 12 inches, after seating 6 inches, is termed the soil N-value and provides an indication of the soil's relative density and strength parameters at the sample location. SPT blow counts in 6-inch increments are recorded on the boring logs. The drill rig was equipped with an automatic hammer system which delivers a more consistent driving energy to the sampler compared to the rope and cathead system.

Recovered samples were sealed, labeled and transported to our laboratory. All soil samples will be discarded after sixty days unless a longer hold time is specifically requested.



Borings were drilled and other sampling was conducted solely to obtain indications of subsurface conditions as part of a geotechnical exploration program. No services were performed to evaluate subsurface environmental conditions.

Laboratory

The recovered soil samples were reviewed by an engineer and technically classified according to the methods of ASTM D2488 "Standard Practice for Description and Identification of Soils (Visual-Manual Procedure)". Estimates of the unconfined compressive strength of the cohesive samples were made using a calibrated penetrometer. A copy of the test boring logs along with a description of the terminology used on the logs and a chart of the ASTM D2488 group symbol names are provided in the Appendix. Selected samples were subjected to various laboratory tests, including:

- ASTM D2216 "Test Methods for Laboratory Determination of Water (Moisture) Content of Soil and Rock by Mass"
- ASTM D4318 "Test Method for Liquid Limit, Plastic Limit and Plasticity Index of Soils"

The samples subjected to plasticity testing were reclassified according to ASTM D2487 procedures "Standard Test Method for Classifications of Soils for Engineering Purposes". The ASTM D2487 and D2488 classifications are included on the boring logs. Results of the laboratory tests have been summarized in a table provided in the Appendix.

INVESTIGATION RESULTS

Regional Geology

The Map of the Surface Formations of the Southern Peninsula of Michigan, published by the State of Michigan, indicates the sites are in an area of moraines. Soil conditions typically are found to be range from clay and silt to sand and gravel with possible cobble and boulder in this type of geologic area. The Map of Bedrock Topography of the Southern Peninsula of Michigan indicates bedrock to be between els 600 to 650 ft at Leslie Park Golf Course, on the



order of 180 to 230 ft below the existing ground surface, and between els 650 to 700 ft at Sylvan Park, on the order of 100 to 150 ft below the existing ground surface.

Site Conditions

Sylvan Park

At the time of our field work, the area of investigation was covered with cut grass lawn and contained an existing tennis court and playground area, bridge and concrete sidewalk extending south from Margaret Drive at the north to the Swift Drain at the south. Densley wooded areas were observed near the existing bridge and extending along the Swift Drain to the northeast and southwest. The site, in general, sloped down from the north and near Margaret Drive (el 800) and from the south near the existing residences on the north side of Eli Drive (el 800) towards the Swift Drain (el 792). The water level in Swift Drain was observed to be at el 793 at the time of our investigation. There were no obvious signs of structural distress, such as readily visible settlement or cracking, on the visible parts of the existing bridge.



Leslie Park Golf Course

At the time of our field work, the site contained the existing bridge and HMA-paved paths. The area of investigation was mostly covered with cut grass lawn, with bushes and tall grass along each side of Traver Creek. The site, in general, sloped towards Traver Creek with elevations ranging from 829 to 837 ft near Traver Road and the existing tee box directly north of the existing bridge. The water level in Traver Creek was observed to be at el 827.6. There were





no obvious signs of structural distress, such as readily visible settlement or cracking, on the visible parts of the existing bridge.

Subsurface Conditions

Sylvan Park – Borings B-1 and B-2

Borings B-1 and B-2 encountered 5 to 9 inches of clayey topsoil. Beneath the topsoil, Borings B-1 and B-2 generally encountered hard lean clay (CL) or dense silt (ML) with occasional sand lenses to the explored depths of 60 ft. As a notable exception, Boring B-1 encountered loose to medium dense clayey sand (SC) below the topsoil to a depth of 8 ft (el 790).

Borings B-1 and B-2 encountered poor sampler recovery due to possible gravel or cobble at depths up to 15 ft (el 783). Borings B-1 and B-2 encountered sampler refusal due to possible coarse gravel or cobble at depths below 35 ft (el 763). Difficult drilling conditions were noted in Boring B-1 below 8.5 ft depth (el 789.5). Boulder may be present where cobble is noted.

Groundwater was encountered in Borings B-1 and B-2 at depths ranging from 4 to 8.5 ft (els 789.5 to 794).

Atterberg Limits testing was performed on samples of gray lean clay (CL) obtained from Boring B-1 at a depth of 20 ft (el 778) and obtained from Boring B-2 at a depth of 25 ft (el 773). The measured liquid limits for the lean clay (CL) samples ranged 22 to 24 and the measured plastic limits ranged from 14 to 15 with moisture contents of 7.6 to 11.6 percent. The recorded moisture contents with respect to the measured plastic limits suggest the lean clays (CL) are likely in an overconsolidated stress state.

Leslie Park Golf Course – Borings B-3 and B-4

Boring B-3 and B-4 encountered 4 and 6 inches of sandy or clayey topsoil at the surface. Below the surficial material, Boring B-3 encountered loose to medium dense poorly graded sand with varying amounts of clay (SP, SP-SC) to a depth of 9 ft (el 824), hard lean clay (CL) to a depth of 19 ft (el 814), dense poorly graded sand (SP) to a depth of 34.5 ft (el 798.5), hard



silt (ML) to a depth of 42 ft (el 791) and hard lean clay (CL) to the explored depth of 60 ft (el 773).

Below the surficial material, Boring B-4 generally encountered stiff to hard lean clay (CL) to a depth of 17 ft (el 816.3), very stiff silt (ML) to a depth of 22 ft (el 811.3), dense to very dense silty sand (SM) to a depth of 42 ft (el 791.3) and hard lean clay (CL) to the explored depth of 60 ft (el 773.3).

Borings B-3 and B-4 encountered sampler refusal due to possible coarse gravel or cobble at depths up to 60 ft (el 773.3). Boulder may be present where cobble is noted.

Groundwater was encountered in Borings B-3 and B-4 at depths ranging from 7.5 to 18.5 ft (els 814.8 to 825.5).

Atterberg Limits testing was performed on samples of gray lean clay (CL) obtained from Boring B-3 at depths of 15 ft (el 818) and 45 ft (el 788). The measured liquid limits for the lean clay (CL) samples ranged 17 to 20 and the measured plastic limits ranged from 10 to 11 with moisture contents of 7.2 to 11 percent. The recorded moisture contents with respect to the measured plastic limits suggest the lean clays (CL) are likely in an overconsolidated stress state.

The relative density of granular soil is based on recorded SPT N-values while the consistency of cohesive soil is based on both recorded SPT N-values and on estimates of the unconfined compressive strength obtained with a calibrated penetrometer.

Groundwater levels will fluctuate due to seasonal variations such as precipitation, snowmelt, nearby river or lake levels and other factors that may not be evident at the time of measurement. Groundwater levels may be different at the time of construction.

This section has provided a generalized description of the encountered subsurface soil conditions. The boring logs located in the Appendix should be reviewed for detailed soil descriptions. Some variation between boring locations may be expected.



CONCLUSIONS AND RECOMMENDATIONS

Foundations

A conventional shallow spread foundation system is recommended for support of the proposed bridge abutments. It is important that the recommendations of this report, in particular those pertaining to subgrade preparation, construction observation and testing, be implemented during design and construction.

The following parameters are recommended for foundation design:

Table 5.1.1 - Foundation Design Parameters

Bearing pressure for square or rectangular foundations, maximum net allowable	3000 psf
Minimum width of square or rectangular foundations, inches	24 inches
Minimum embedment depth for frost protection, inches	42 inches

Foundations are expected to bear on the medium dense poorly graded sand with varying amounts of clayey fines (SP-SC, SC) or hard lean clay (CL) as encountered in the borings or on approved engineered fill. Subgrade preparation recommendations are contained in the following section.

Foundation recommendations presented herein are based on a safety factor to resist bearing capacity failure of at least 3.0 and a maximum anticipated total foundation settlement of 1 inch or less.

Site and Subgrade Preparation

All topsoil, vegetation, roots, and any other miscellaneous debris should be removed from within the proposed construction areas.

Due to loose sand encountered in Borings B-1 to B-3 near foundation bearing elevations and due to variations that may exist between borings, it is possible that some form of subgrade improvement may be required to provide suitable foundation bearing conditions. Subgrade



improvement may include, but not be necessarily limited to, densification of existing soil in-place or excavation of all unsuitable material to an approved subgrade and replacement with engineered fill. If overexcavation is selected, it should encompass soil within the stress influence region of the foundation, defined as a region bordered by 2V:1H planes extending down and away from the bottom edge of the foundation to the approved bearing stratum.

The foundation subgrade should be inspected and tested by qualified geotechnical personnel. As part of the inspection and testing, the subgrade at each individual bearing element should be verified to be consistent with the conditions encountered in this investigation and the indicated recommended allowable bearing pressures. This testing should include the verification of acceptable unconfined compressive strengths in cohesive soil and a dynamic cone penetrometer (ASTM STP 399) to verify minimum relative densities and equivalent N -values in granular soil. Care should be taken to maintain the natural moisture content of clayey subgrade soil which may become soft when saturated from rainfall, etc.

Engineered fill is approved on-site or imported soil placed in uniform layers and compacted to a minimum required density. Generally, on-site soil with group symbols of SP or SP-SM are expected to be suitable for engineered fill. Imported engineered fill should meet the requirements for MDOT Class II granular material. MDOT Class II soil or approved on-site soil meeting the requirements of SP or SP-SM should be used as backfill against foundations.

Granular engineered fill and backfill should be compacted to at least 95 percent of the soil's maximum dry density as determined by the Modified Proctor test (ASTM D1557). Vibratory compaction methods are typically found to be most effective in granular soils. The fill should be placed and compacted in horizontal layers not exceeding 9 inches. Field density tests should be taken on each lift, as the fill is being placed, to verify compliance with compaction specifications. If the earthwork takes place during winter months, fill must not be placed on frozen ground and fill with frozen conglomerations of soil must not be used.

Because the sites have been previously developed, there may be buried items not encountered in our borings, such as a septic tank, well, or utility conduit, which may cause settlement problems. The contract documents should reflect that it is necessary to remove or relocate such structures and to fill the excavation with engineered fill.



Groundwater

At Sylvan Park, groundwater was encountered in Borings B-1 and B-2 at depths of 4 to 8.5 ft (els 789.5 to 794), and the Swift Drain water level was observed at el 793. At Leslie Park, groundwater was encountered in Borings B-3 and B-4 at depths ranging from 7.5 to 18.5 ft (els 814.8 to 825.5), and the Traver Creek water level was observed at el 827.6. Considering foundations will be constructed below the provided scour elevation (Sylvan Park el 792.5, Leslie Park el 826), groundwater was generally encountered above or close to the anticipated depths of excavation for foundation construction and site preparation.

Groundwater will likely be encountered during construction and suitable control of groundwater should be anticipated and planned for accordingly before the start of construction. The Contractor should be responsible for selecting and implementing an appropriate groundwater control system. The Contractor should have previous dewatering experience on sites with similar conditions. Suitable silt and sediment traps should be incorporated into the dewatering system.

Slopes and Temporary Excavations

The Owner and the Contractor should make themselves aware of and become familiar with applicable local, state, and federal safety regulations, including current OSHA excavation and trench safety standards. Construction site safety generally is the sole responsibility of the Contractor. The Contractor shall also be solely responsible for the means, methods, techniques, sequences and operations of construction operations. We are providing the following information solely as a service on this project and, under no circumstances, should our provision of the following information be construed to mean that we are assuming responsibility for construction site safety or the Contractor's activities; such responsibility is not implied and should not be inferred.

The Contractor should be aware that slope height, slope inclination, and excavation depths (including utility trench excavations) should in no case exceed those specified in local, state, or federal safety regulations; e.g., OSHA Health and Safety Standards for Excavations, 29 CFR Part 1926, or successor regulations. For this site, the overburden soil encountered in our



exploratory program is a combination of cohesive and granular soil. We anticipate that OSHA will classify these materials as Types A and C, respectively. OSHA recommends a maximum slope inclination of $\frac{3}{4}H:1V$ for Type A and $1\frac{1}{2}H:1V$ for Type C soil under ideal conditions. If excavations within the Type A soil are open less than 24 hours and are 12 ft or less in depth, then OSHA allows the maximum slope inclination to be $1/2H:1V$ under ideal conditions.

As an alternative to temporary slopes, vertical excavations can be temporarily shored. The Contractor or the specialty subcontractor should be responsible for the design of the temporary shoring in accordance with applicable regulatory requirements.

Below-Grade Walls

The lateral earth pressure against below-grade walls is a function of the rigidity of the wall, the nature of the backfill material, the slope of the top surface of the retained soil and surcharge loads. For design of cantilever retaining walls, the following soil parameters may be used:

Cantilever Wall Lateral Earth Pressures

Coefficient of active earth pressure	0.33
Coefficient of passive earth pressure	3.0
Friction angle of backfill	32 degrees
Total unit weight of backfill	120 pcf
Friction angle between smooth concrete and backfill	20 degrees
Friction angle between rough concrete and sand subgrade	24 degrees
Friction angle between rough concrete and clay subgrade	20 degrees

Any possible surcharge loads should be included in the design of all earth-retaining structures.

MBC Seismic Considerations

The seismic design category can be determined with noted exceptions following Section 1613 of the 2015 Michigan Building Code. The Risk Category under Section 1613.3.5 shall be determined by a licensed structural engineer. Based on the subsurface conditions identified in the soil borings, our experience with the geological conditions in the site vicinity and the procedures outlined in Section 1613 of the 2015 Michigan Building Code and Chapter 20,



Table 20.3-1 of ASCE 7, we recommend assigning a Site Class D to this site. A Site Class D designates a stiff soil profile in the upper 100 ft with average SPT uncorrected N-values between 15 and 50 in granular soil and average undrained shear strengths, s_u , between 1,000 and 2,000 psf in cohesive soil. Recommended seismic ground motion values are provided below.

Recommended Seismic Ground Motion Values

2015 Michigan Building Code Values	Short Period (0.2 sec)	Long Period (1 sec)
Spectral Response Acceleration, Figure 1613.3.1(1 and 2), %g	$S_s = 9$	$S_l = 5$
Seismic Site Coefficient, Table 1613.3.3(1 and 2)	$F_a = 1.6$	$F_v = 2.4$
Maximum Considered Spectral Response Acceleration, Equations 16-37 and 16-38	$S_{MS} = 0.144g$	$S_{MI} = 0.120g$
5% Damped Spectral Response Acceleration, Equations 16-39 and 16-40	$S_{DS} = 0.096g$	$S_{DI} = 0.080g$

CLOSURE

In this report, descriptions of the geotechnical investigation, encountered conditions, and recommendations for the design of foundations and earth-related structures have been provided. The limitations of this study are described in the Appendix.

The recommendations presented in this report are based upon a limited number of subsurface samples obtained from various sampling locations. The samples may not fully indicate the nature and extent of the variations that actually exist between sampling locations. For that reason, among others, we strongly recommend that a qualified geotechnical firm be retained to observe earthwork construction. If variations or other latent conditions become evident during construction, it will be necessary for us to review these conditions and our recommendations as appropriate.



We appreciate this opportunity to provide foundation engineering services and express our interest in providing continuing services in the areas of subgrade verification, special inspections and quality assurance testing on various construction materials. Please contact our office should you have any questions or require further assistance.

Sincerely,

MATERIALS TESTING CONSULTANTS, INC.

Ryan D. Starcher, E.I.T.
Project Engineer

Robert J. Warren, P.E.
Project Manager

Attachments: Figure Nos. 1 and 2 - Boring Location Plans

Appendix

- Limitations
- Test Drilling and Sampling Procedures
- Boring Log Terminology and Classification Outline
- Boring Logs
- Summary of Laboratory Test Data

LEGEND

 BORING LOCATION (TYP)

NOTE: AERIAL IMAGE FROM GOOGLE EARTH

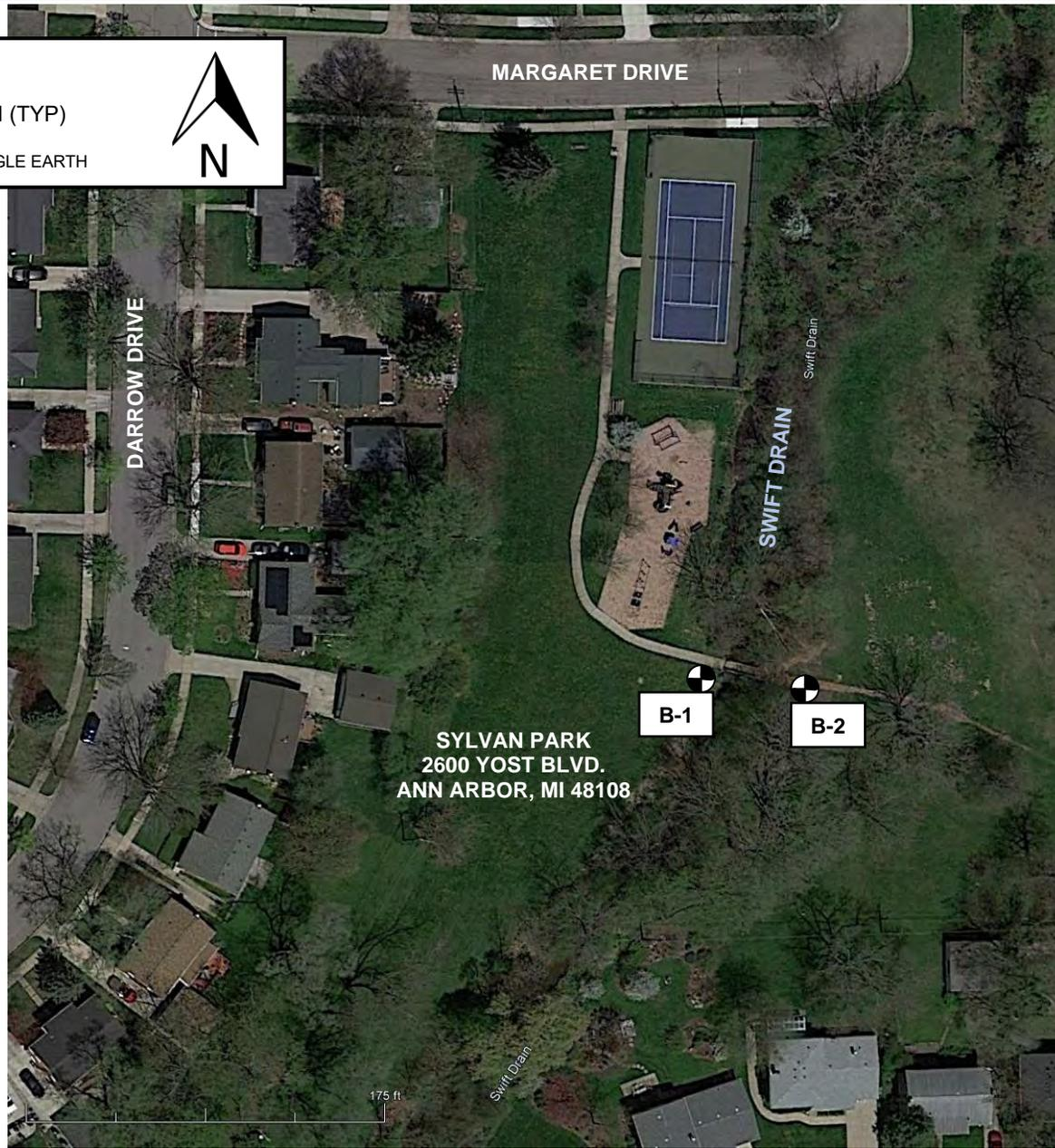

TITLE: BORING LOCATION PLAN		PROJECT: CITY OF ANN ARBOR PEDESTRIAN BRIDGES – SYLVAN PARK	
SCALE: AS SHOWN	DATE: 12/14/2023	PROJECT NO.: 231294	
FIG. NO.: 1	DR. BY: RS	REV. BY: RW	

LEGEND

 BORING LOCATION (TYP)

NOTE: AERIAL IMAGE FROM GOOGLE EARTH



LESLIE PARK GOLF COURSE
2120 TRAVER ROAD
ANN ARBOR, MI 48105

TITLE: BORING LOCATION PLAN

PROJECT: CITY OF ANN ARBOR PEDESTRIAN BRIDGES – LESLIE PARK GOLF COURSE

SCALE: AS SHOWN

DATE: 12/14/2023

PROJECT NO.: 231294

FIG. NO.: 2

DR. BY: RS

REV. BY: RW





LIMITATIONS

Soil Variations

The recommendations in this report are based upon the data obtained from the soil borings. This report does not reflect variations which may occur between these borings, and which would not become evident until construction. If variations then become evident, it would be necessary for a re-evaluation of recommendations of this report, after performing on-site observations.

Warranties

We have prepared this report in accordance with generally accepted soil and foundation engineering practices. We make no other warranties, either expressed or implied, as to the professional advice provided under the terms of our agreement and included in this report. This report is prepared exclusively for our client and may not be relied upon by other parties without written consent from our office.

Boring Logs

In the process of obtaining and testing samples and preparing this report, we follow reasonable and accepted practice in the field of soil engineering. Field logs maintained during drilling describe field occurrences, sampling locations, and other information. The samples obtained in the field are subjected to additional testing in the laboratory and differences may exist between the field logs and the final logs. The engineer reviews the field logs and laboratory test data, and then prepares the final boring logs. Our recommendations are based on the contents of the final logs.

Review of Design Plans and Specifications

In the event that any changes in the design of the building or the location, however slight, are planned, our recommendations shall not be considered valid unless modified or approved in writing by our office. We recommend that we be provided the opportunity to review the final design and specifications in order to determine whether changes in the original concept may have affected the validity of our recommendations, and whether our recommendations have, in fact, been implemented in the design and specifications.



TEST DRILLING AND SAMPLING PROCEDURES

Test Drilling Methods:

- Hollow stem auger, ASTM D6151
- Mud rotary, ASTM D5783
- Casing advancer, ASTM D5872
- Rock coring, ASTM D2113
- Core/Hand Auger

Note: Cone penetration test data can be used to interpret subsurface stratigraphy and can provide data on engineering properties of soils. The ASTM procedure does not include a procedure for determining soil classification from CPT testing. Soil classifications shown on CPT logs are based on published procedures and are not based on physical ASTM soil classification tests.

Sampling Methods:

- SPT, ASTM D1586, Auto hammer (140 lb., 30" drop, 2" OD split spoon sampler)
- Thin-walled tube sampler (Shelby), ASTM D1587

Note: The number of hammer blows required to drive the SPT sampler 12 inches, after seating 6 inches, is termed the soil N-value and provides an indication of the soil's relative density and strength parameters at the sample location. SPT blow counts in 6 inch increments are recorded on the boring logs.

Drill Rig:

- CME 55 LC (ATV)
- CME 750 Rubber tired (ATV)
- Acker Renegade
- Geoprobe Direct Push
- Geoprobe Rotary Sonic

Boreholes Backfilled With:

- Excavated soil
- Cement bentonite grout
- Piezometer or Monitoring Well (see notes on logs)
- Concrete or asphalt patch where appropriate

Sample Handling and Disposition:

- Samples labeled, placed in jars, returned to MTC Laboratory
- Discard after 60 days



BORING LOG TERMINOLOGY AND ASTM D 2488 CLASSIFICATION OUTLINE

TERMS DESCRIBING CONSISTENCY OR CONDITION

COARSE-GRAINED SOILS (major portions retained on No. 200 sieve): includes (1) clean gravel and sands and (2) silty or clayey gravels and sands. Condition is rated according to relative density as determined by laboratory tests or standard penetration resistance tests.

Descriptive Terms	Relative Density	SPT Blow Count
Very loose	0 to 15 %	< 5
Loose	15 to 35 %	5 to 10
Medium dense	35 to 65 %	10 to 30
Dense	65 to 85 %	30 to 50
Very dense	85 to 100 %	> 50

Per ASTM D2487, the following conditions must be met based on laboratory testing to justify the label 'well graded' in a soil description.

Gravel: $C_u = \frac{D_{60}}{D_{10}}$ greater than 4; $C_c = \frac{(D_{30})^2}{D_{10} \times D_{60}}$ between 1 and 3

Sand: $C_u = \frac{D_{60}}{D_{10}}$ greater than 6; $C_c = \frac{(D_{30})^2}{D_{10} \times D_{60}}$ between 1 and 3

FINE-GRAINED SOILS (major portions passing on No. 200 sieve): includes (1) inorganic and organic silts and clays, (2) gravelly, sandy, or silty clays, and (3) clayey silts. Consistency is rated according to shearing strength, as indicated by penetrometer readings, SPT blow count, or unconfined compression tests.

Descriptive Terms	Unconfined Compressive Strength TSF	SPT Blow Count
Very soft	< 0.25	< 2
Soft	0.25 to 0.5	2 to 4
Medium stiff	0.5 to 1.0	4 to 8
Stiff	1.0 to 2.0	8 to 15
Very stiff	2.0 to 4.0	15 to 30
Hard	> 4.0	> 30

Plasticity Chart

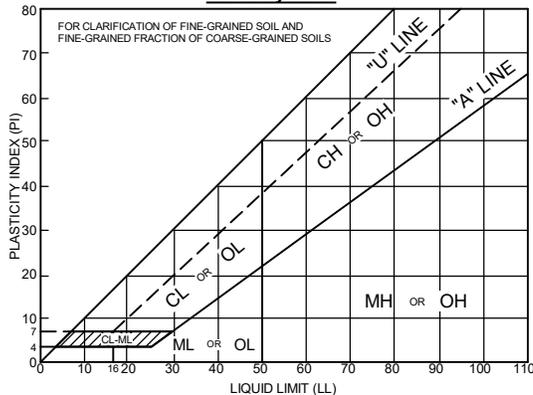

MAJOR DIVISIONS				TYPICAL NAMES
COARSE-GRAINED SOILS MORE THAN HALF IS COARSER THAN NO. 200 SIEVE	GRAVELS MORE THAN HALF COARSE FRACTION IS LARGER THAN NO. 4 SIEVE	CLEAN GRAVELS WITH LESS THAN 15% FINES	GW	WELL-GRADED GRAVELS WITH OR WITHOUT SAND
		GRAVELS WITH 15% OR MORE FINES	GP	POORLY-GRADED GRAVELS WITH OR WITHOUT SAND
			GM	SILTY GRAVELS WITH OR WITHOUT SAND
		GC	CLAYEY GRAVELS WITH OR WITHOUT SAND	
	SANDS MORE THAN HALF COARSE FRACTION IS FINER THAN NO. 4 SIEVE SIZE	CLEAN SANDS WITH LESS THAN 15% FINES	SW	WELL-GRADED SANDS WITH OR WITHOUT GRAVEL
			SP	POORLY-GRADED SANDS WITH OR WITHOUT GRAVEL
		SANDS WITH 15% OR MORE FINES	SP-SM	POORLY-GRADED SANDS WITH SILT WITH OR WITHOUT GRAVEL
			SM	SILTY SANDS WITH OR WITHOUT GRAVEL
		SC	CLAYEY SANDS WITH OR WITHOUT GRAVEL	
		FINE-GRAINED SOILS MORE THAN HALF IS FINER THAN NO. 200 SIEVE	SILTS AND CLAYS LIQUID LIMIT 50% OR LESS	ML
CL	INORGANIC CLAYS OF LOW TO MEDIUM PLASTICITY WITH OR WITHOUT SAND OR GRAVEL			
OL	ORGANIC SILTS OR CLAYS OF LOW TO MEDIUM PLASTICITY WITH OR WITHOUT SAND OR GRAVEL			
SILTS AND CLAYS LIQUID LIMIT GREATER THAN 50%	MH		INORGANIC SILTS OF HIGH PLASTICITY WITH OR WITHOUT SAND OR GRAVEL	
	CH		INORGANIC CLAYS OF HIGH PLASTICITY WITH OR WITHOUT SAND OR GRAVEL	
	OH		ORGANIC SILTS OR CLAYS OF HIGH PLASTICITY WITH OR WITHOUT SAND OR GRAVEL	
HIGHLY ORGANIC SOILS		PT/OL	PEAT AND OTHER HIGHLY ORGANIC SOILS	

GENERAL NOTES

- Classifications are based on the United Soil Classification System and include consistency, moisture, and color. Field descriptions have been modified to reflect results of laboratory tests where deemed appropriate.
- "Grades with" or "Grades without" may be used to describe soil when characteristics vary within a stratum.
- Preserved soil samples will be discarded after 60 days unless alternate arrangements have been made.

GROUNDWATER OBSERVATIONS:

During - indicates water level encountered during the boring
End - indicates water level immediately after drilling
Date and Depth - Measurements at indicated date

SAMPLE TYPES AND NUMBERING

S	SPT, split barrel sample, ASTM D1586
U	Shelby tube sample, ASTM D1587
R	Rock core run
*S	Other than 2" split barrel sample
L	SPT with liner, ASTM D1586
A	Auger cuttings
G	Geoprobe liner

MINOR COMPONENT QUANTIFYING TERMS

Less than 5%	TRACE
5 to 10%	FEW
15 to 25%	LITTLE
30 to 40%	SOME
50 to 100%	MOSTLY

GRAIN SIZE

BOULDER	>12"
COBBLE	12" to 3"
COARSE GRAVEL	3" to 0.75"
FINE GRAVEL	0.75" to No. 4
COARSE SAND	No. 4 to No. 10
MEDIUM SAND	No. 10 to No. 40
FINE SAND	No. 40 to No. 200



LOG OF BORING

Project No.: 231294

Boring No.: B-1

Sheet: 1 of 2

Project: Ann Arbor Pedestrian Bridge Repairs

Client: Stantec

Location: Sylvan Park, Ann Arbor, Michigan

Drill Type: Acker Renegade

Crew Chief: NB **Field Eng.:** JV **Rev. By:** RS

Coordinates: N=274635.0 E=13307448.0 (MI South lift)

Elevation: 798.0 ft **Datum:** NAVD 88 (GPS Observation)

Notes:

Date Begin: 07/19/2023

Date End: 07/20/2023

Tooling	Type	Dia.	Groundwater, ft.	
Casing	HSA	4 1/4"	During	4.0
Sampler	SPT	2"	End	NA
Core			Delayed Groundwater, ft.	
Tube			Date	Depth, ft.
SPT Hammer				

Plugging Record: Backfilled borehole with compacted cuttings. Cave in at 38.0 ft.

Depth Drilled: 60.0 ft.

Component Percentages: Trace < 5%, Few 5-10%, Little 15-25%, Some 30-45%, Mostly 50-100%

QP = Calibrated Penetrometer (tons/sq. ft.)

Elev. FT.	Depth FT.	Sample Number	Recov. FT.	Penetration (Blows Per 6") ASTM D 1586	*USCS Group Symbol	*DESCRIPTION	QP tsf	MST %	DD pcf	REMARKS
797.0	1	S-1	1.1	2-3-3 N=6		9" Clayey Topsoil	0.8			S-1: Poor recovery; possible coarse gravel / COBBLE
796.0	2					Brown clayey SAND; mostly medium to fine sand, little clayey fines, moist				
795.0	3									
794.0	4	S-2	1.5	3-4-5 N=9	SC	Grades gray with clay seams, wet				
793.0	5									
792.0	6									
791.0	7	S-3	1.5	4-7-9 N=16			4.5+		Augers charged with water at 8.5'	
790.0	8						8.0			
789.0	9	S-4	1.5	7-8-8 N=16	CL	Gray sandy lean CLAY; mostly clayey fines, some coarse to fine sand, moist		11.7		Hard drilling from 8.5' to 60.0'
788.0	10									
787.0	11									
786.0	12	S-5	1.5	16-19-23 N=42	CL	Gray lean CLAY with sand; mostly clayey fines, little coarse to fine sand, trace coarse to fine gravel, moist	4.5+	8.3		
785.0	13									
784.0	14									
783.0	15	S-6	1.5	13-18-22 N=40	CL	Gray lean CLAY; mostly clayey fines, few fine sand, moist	4.5	7.6		S-6: Atterberg Limits ASTM D4318: LL = 24, PL = 14, PI = 10
782.0	16									
781.0	17									
780.0	18	S-7	1.5	17-25-23 N=48	ML	Gray SILT; mostly silty fines, moist				
779.0	19									
778.0	20									
777.0	21	S-8	1.5	21-24-34 N=58	CL	Gray lean CLAY; mostly clayey fines, few medium to fine sand, moist	4.5+	9.8		
776.0	22									
775.0	23									
774.0	24	S-9	1.5	16-36-50/4"	SP-SM	Gray poorly graded SAND with silt and gravel; mostly coarse to fine sand, little coarse to fine gravel, few silty fines, wet				S-9, S-12: Sampler Refusal due to possible coarse gravel or COBBLE
773.0	25									
772.0	26									
771.0	27	S-10	1.5	19-20-39 N=59	CL	Gray lean CLAY; mostly clayey fines, few medium to fine sand, trace fine gravel, moist	4.5+	13.2		
770.0	28									
769.0	29									
768.0	30									
767.0	31									
766.0	32									
765.0	33									
764.0	34									
763.0	35									
762.0	36									
761.0	37									
760.0	38									
759.0	39									
758.0	40									

* Visual estimate following ASTM D 2488 unless laboratory testing has been performed. Stratification changes are approximated between samples.



LOG OF BORING

Project No.: 231294

Boring No.: B-1

Sheet: 2 of 2

Component Percentages: Trace < 5%, Few 5-10%, Little 15-25%, Some 30-45%, Mostly 50-100%

QP = Calibrated Penetrometer (tons/sq. ft.)

Elev. FT.	Depth FT.	Sample Number	Recov. FT.	Penetration (Blows Per 6") ASTM D 1586	*USCS Group Symbol	*DESCRIPTION	QP tsf	MST %	DD pcf	REMARKS	
757.0	41	S-11	1.5	15-21-39 N=60	CL	Gray lean CLAY; mostly clayey fines, few medium to fine sand, trace fine gravel, moist	4.5+	19.2			
756.0	42										
755.0	43										
754.0	44										
753.0	45										
752.0	46	S-12	0.8	34-50/4"	ML	Grades without sand	47.0				
751.0	47										
750.0	48										
749.0	49										
748.0	50										
747.0	51	S-13	1.5	17-30-42 N=72	CL	Gray SILT; mostly silty fines, trace fine gravel, moist	52.0				
746.0	52										
745.0	53										
744.0	54										
743.0	55										
742.0	56	S-14	1.5	13-24-36 N=60	CL	Gray lean CLAY; mostly clayey fines, few silty fines, moist with silt seams	4.5+	13.9			
741.0	57										
740.0	58										
739.0	59										
738.0	60										
End of Boring							60.0	4.5+	16.6		

* Visual estimate following ASTM D 2488 unless laboratory testing has been performed. Stratification changes are approximated between samples.



LOG OF BORING

Project No.: 231294

Boring No.: B-2

Sheet: 1 of 2

Project: Ann Arbor Pedestrian Bridge Repairs
 Client: Stantec
 Location: Sylvan Park, Ann Arbor, Michigan
 Drill Type: Acker Renegade
 Crew Chief: NB Field Eng.: JV Rev. By: RS
 Coordinates: N=274633.4 E=13307496.7 (MI South lift)
 Elevation: 798.0 ft Datum: NAVD 88 (GPS Observation)
 Notes:
 Plugging Record: Backfilled borehole with compacted cuttings. Cave in at 36.0 ft.

Date Begin: 07/19/2023 Date End: 07/19/2023

Tooling	Type	Dia.	Groundwater, ft.	
Casing	HSA	4 1/4"	During	8.5
Sampler	SPT	2"	End	NA
Core			Delayed Groundwater, ft.	
Tube			Date	Depth, ft.
SPT Hammer				

Depth Drilled: 60.0 ft.

Component Percentages: Trace < 5%, Few 5-10%, Little 15-25%, Some 30-45%, Mostly 50-100%

QP = Calibrated Penetrometer (tons/sq. ft.)

Elev. FT.	Depth FT.	Sample Number	Recov. FT.	Penetration (Blows Per 6") ASTM D 1586	*USCS Group Symbol	*DESCRIPTION	QP tsf	MST %	DD pcf	REMARKS
797.0	1	S-1	1.2	3-4-5 N=9	CL	5" Clayey Topsoil	0.4	6.9		
796.0	2					Brown poorly graded SAND with clay; mostly coarse to fine sand, few clayey fines, moist				
795.0	3									
794.0	4									
793.0	5	S-2	1.5	11-11-22 N=33	CL		4.5+	13.1		
792.0	6									
791.0	7	S-3	0.1	16-18-29 N=47	CL		-	12.0		
790.0	8									
789.0	9	S-4	1.5	6-5-4 N=9	SP-SM		8.8	4.0		
788.0	10					Brown poorly graded SAND with silt; mostly coarse to fine sand, few silty fines, wet	9.7			
787.0	11									
786.0	12	S-5	0.9	24-26-30 N=56	CL	Gray lean CLAY; mostly clayey fines, few coarse to fine sand, trace fine gravel, moist	12.0	4.5+	7.5	Augers charged with water at 10.0'
785.0	13									
784.0	14									
783.0	15									
782.0	16	S-6	1.5	24-43-49 N=92	CL	Gray gravelly lean CLAY with sand; mostly clayey fines, little coarse to fine gravel, little coarse to fine sand, moist	17.0	4.5+	11.1	
781.0	17									
780.0	18									
779.0	19									
778.0	20	S-7	1.5	26-38-48 N=86	CL	Gray lean CLAY; mostly clayey fines, few fine sand, moist		4.5+	11.6	S-7: Atterberg Limits ASTM D4318: LL = 22, PL = 15, PI = 7
777.0	21									
776.0	22									
775.0	23									
774.0	24	S-8	1.5	16-26-34 N=60	CL			4.5+	8.7	
773.0	25									
772.0	26									
771.0	27									
770.0	28	S-9	1.5	17-30-40 N=70	CL	Grades with few coarse to fine sand		4.5+	10.5	
769.0	29									
768.0	30									
767.0	31									
766.0	32	S-10	0.8	49-50/4"	ML					
765.0	33									
764.0	34									
763.0	35									
762.0	36									
761.0	37						37.0			
760.0	38					Gray SILT; mostly silty fines, moist				
759.0	39									
758.0	40									

* Visual estimate following ASTM D 2488 unless laboratory testing has been performed. Stratification changes are approximated between samples.



LOG OF BORING

Project No.: 231294

Boring No.: B-2

Sheet: 2 of 2

Component Percentages: Trace < 5%, Few 5-10%, Little 15-25%, Some 30-45%, Mostly 50-100%

QP = Calibrated Penetrometer (tons/sq. ft.)

Elev. FT.	Depth FT.	Sample Number	Recov. FT.	Penetration (Blows Per 6") ASTM D 1586	*USCS Group Symbol	*DESCRIPTION	QP tsf	MST %	DD pcf	REMARKS	
757.0	41	S-11	1.5	20-25-39 N=64	ML	Gray SILT; mostly silty fines, moist	4.5+	15.4			
756.0	42										42.0
755.0	43										
754.0	44										
753.0	45										
752.0	46										
751.0	47	S-12	0.2	50/3"	CL	Gray lean CLAY; mostly clayey fines, few medium to fine sand, moist	4.5+			S-10, S-12, S-14: Sampler refusal; possible coarse gravel / COBBLE	
750.0	48										
749.0	49										
748.0	50										
747.0	51										
746.0	52										
745.0	53	S-13	1.5	25-40-40 N=80	CL	Silt lense from 54.3' to 54.8'	4.5+	17.4			
744.0	54										
743.0	55										
742.0	56										
741.0	57										
740.0	58										
739.0	59	S-14	0.9	29-50/5"	CL	Grades with trace fine gravel	60.0				
738.0	60										
						End of Boring					

* Visual estimate following ASTM D 2488 unless laboratory testing has been performed. Stratification changes are approximated between samples.



LOG OF BORING

Project No.: 231294

Boring No.: B-3

Sheet: 1 of 2

Project: Ann Arbor Pedestrian Bridge Repairs
 Client: Stantec
 Location: Sylvan Park, Ann Arbor, Michigan
 Drill Type: Acker Renegade
 Crew Chief: NB Field Eng.: IA/JV Rev. By: RS
 Coordinates: N=293404.5 E=13296549.3 (MI South lift)
 Elevation: 833.0 ft Datum: NAVD 88 (GPS Observation)
 Notes:

Date Begin: 07/18/2023 Date End: 07/18/2023

Tooling	Type	Dia.	Groundwater, ft.	
Casing	HSA	4 1/4"	During	7.5
Sampler	SPT	2"	End	NA
Core			Delayed Groundwater, ft.	
Tube			Date	Depth, ft.
SPT Hammer				

Plugging Record: Backfilled borehole with compacted cuttings. Cave in at 21.0 ft.

Depth Drilled: 60.0 ft.

Component Percentages: Trace < 5%, Few 5-10%, Little 15-25%, Some 30-45%, Mostly 50-100%

QP = Calibrated Penetrometer (tons/sq. ft.)

Elev. FT.	Depth FT.	Sample Number	Recov. FT.	Penetration (Blows Per 6") ASTM D 1586	*USCS Group Symbol	*DESCRIPTION	QP tsf	MST %	DD pcf	REMARKS
832.0	1	S-1	1.4	3-3-3 N=6	SP	6" Sandy Topsoil	4.0	18.3		
831.0	2					Brown poorly graded SAND; mostly coarse to fine sand, few medium to fine gravel, trace silty fines, moist				
830.0	3									
829.0	4	S-2	1.5	7-11-11 N=22	SP		4.5			
828.0	5					Gray poorly graded SAND with clay; mostly coarse to fine sand, few clayey fines, trace coarse to fine gravel, moist				
827.0	6									
826.0	7	S-3	1.5	5-4-5 N=9	SP-SC	Grades wet at 7.5'	9.0	4.0	18.3	Charged augers with water at 8.0'
825.0	8									
824.0	9									
823.0	10	S-4	1.5	3-4-5 N=9	CL	Gray lean CLAY; mostly clayey fines, moist	4.5	11.0		S-5: Atterberg Limits ASTM D4318: LL = 20, PL = 11, PI = 9
822.0	11									
821.0	12									
820.0	13	S-5	1.5	9-11-16 N=27	CL		19.0			
819.0	14									
818.0	15									
817.0	16	S-6	1.5	21-23-24 N=47	SP	Gray poorly graded SAND; mostly coarse to fine sand, trace clayey fines, wet	34.5			
816.0	17									
815.0	18									
814.0	19	S-7	1.5	10-13-20 N=33	SP					
813.0	20									
812.0	21									
811.0	22	S-8	1.5	7-13-22 N=35	SP	Grades without clayey fines				
810.0	23									
809.0	24									
808.0	25	S-9	1.5	18-24-30 N=54	ML	Gray SILT with sand; mostly silty fines, little medium to fine sand, wet				S-10: Sampler refusal; possible coarse gravel / COBBLE
807.0	26									
806.0	27									
805.0	28	S-10	0.9	21-50/9.5"	ML	Grades without sand				
804.0	29									
803.0	30									
802.0	31									
801.0	32									
800.0	33									
799.0	34									
798.0	35									
797.0	36									
796.0	37									
795.0	38									
794.0	39									
793.0	40									

* Visual estimate following ASTM D 2488 unless laboratory testing has been performed. Stratification changes are approximated between samples.



LOG OF BORING

Project No.: 231294

Boring No.: B-3

Sheet: 2 of 2

Component Percentages: Trace < 5%, Few 5-10%, Little 15-25%, Some 30-45%, Mostly 50-100%

QP = Calibrated Penetrometer (tons/sq. ft.)

Elev. FT.	Depth FT.	Sample Number	Recov. FT.	Penetration (Blows Per 6") ASTM D 1586	*USCS Group Symbol	*DESCRIPTION	QP tsf	MST %	DD pcf	REMARKS	
792.0	41	S-11	1.5	16-28-36 N=64	ML	Gray SILT; mostly silty fines, wet	4.5+	7.2			
791.0	42										42.0
790.0	43										
789.0	44										
788.0	45	S-12	1.3	24-38-50/4"	CL	Gray lean CLAY; mostly clayey fines, some silty fines, few fine sand, trace fine gravel, moist	4.5+	11.0		S-12 and S-13: Sampler refusal; possible coarse gravel / COBBLE	
787.0	46										
786.0	47										
785.0	48										
784.0	49	S-13	1.4	12-27-50/5"	CL		4.5+	11.8			
783.0	50										
782.0	51										
781.0	52										
780.0	53	S-14	1.5	14-20-22 N=42	CL	Grades brown with few coarse to fine sand	4.5+	10.3			
779.0	54										
778.0	55										
777.0	56										
776.0	57										
775.0	58										
774.0	59										
773.0	60					End of Boring					

* Visual estimate following ASTM D 2488 unless laboratory testing has been performed. Stratification changes are approximated between samples.



LOG OF BORING

Project No.: 231294

Boring No.: B-4

Sheet: 1 of 2

Project: Ann Arbor Pedestrian Bridge Repairs
 Client: Stantec
 Location: Sylvan Park, Ann Arbor, Michigan
 Drill Type: Acker Renegade
 Crew Chief: NB Field Eng.: JV Rev. By: RS
 Coordinates: N=293385.5 E=13296597.7 (MI South lift)
 Elevation: 833.3 ft Datum: NAVD 88 (GPS Observation)
 Notes:

Date Begin: 07/17/2023 Date End: 07/17/2023

Tooling	Type	Dia.	Groundwater, ft.	
Casing	HSA	4 1/4"	During	18.5
Sampler	SPT	2"	End	NA
Core			Delayed Groundwater, ft.	
Tube			Date	Depth, ft.
SPT Hammer				

Plugging Record: Backfilled borehole with compacted cuttings, patched pavement with cold patch. Cave in at 25.0 ft.

Depth Drilled: 60.0 ft.

Component Percentages: Trace < 5%, Few 5-10%, Little 15-25%, Some 30-45%, Mostly 50-100%

QP = Calibrated Penetrometer (tons/sq. ft.)

Elev. FT.	Depth FT.	Sample Number	Recov. FT.	Penetration (Blows Per 6") ASTM D 1586	*USCS Group Symbol	*DESCRIPTION	QP tsf	MST %	DD pcf	REMARKS	
832.3	1	S-1	1.5	9-5-3 N=8	SP	4" Clayey Topsoil	0.3	3.0			
831.3	2				CL	Brown poorly graded sand; mostly coarse to fine sand, moist	0.8				
830.3	3	S-2	1.5	4-7-10 N=17	CL	Brown lean CLAY with sand; mostly clayey fines, little medium to fine sand, moist	4.3	3.0			
829.3	4				GP	Gray poorly graded GRAVEL; mostly coarse to fine gravel, moist					5.5
828.3	5				CL	Gray lean CLAY; mostly clayey fines, little silty fines, few fine sand, moist with wet sand seams					
827.3	6	S-3	1.5	5-4-5 N=9	CL		4.5+	14.8			
826.3	7										
825.3	8	S-4	1.5	6-5-7 N=12	CL		4.5+	18.5			
824.3	9										
823.3	10										
822.3	11	S-5	1.5	10-11-12 N=23	CL		4.5+	15.7			
821.3	12										
820.3	13										
819.3	14	S-6	1.5	10-11-11 N=22	ML	Gray SILT; mostly silty fines, few fine sand, moist Grades wet at 18.5'	17.0				
818.3	15										
817.3	16										
816.3	17	S-7	1.5	9-25-39 N=64	SM	Gray silty SAND; mostly medium to fine sand, little silty fines, wet	22.0			Augers charged with water at 24.0'	
815.3	18										
814.3	19										
813.3	20	S-8	1.5	6-12-20 N=32	SM						
812.3	21										
811.3	22										
810.3	23	S-9	1.5	8-11-22 N=33	SM						
809.3	24										
808.3	25										
807.3	26	S-10	0.9	37-50/5"	SM	Grades with some silty fines				S-10: Sampler refusal; possible coarse gravel / COBBLE	
806.3	27										
805.3	28										
804.3	29										
803.3	30										
802.3	31										
801.3	32										
800.3	33										
799.3	34										
798.3	35										
797.3	36										
796.3	37										
795.3	38										
794.3	39										
793.3	40										

* Visual estimate following ASTM D 2488 unless laboratory testing has been performed. Stratification changes are approximated between samples.



LOG OF BORING

Project No.: 231294

Boring No.: B-4

Sheet: 2 of 2

Component Percentages: Trace < 5%, Few 5-10%, Little 15-25%, Some 30-45%, Mostly 50-100%

QP = Calibrated Penetrometer (tons/sq. ft.)

Elev. FT.	Depth FT.	Sample Number	Recov. FT.	Penetration (Blows Per 6") ASTM D 1586	*USCS Group Symbol	*DESCRIPTION	QP tsf	MST %	DD pcf	REMARKS		
792.3	41	S-11	0.5	50/5.5"	SM	Gray silty SAND; mostly medium to fine sand, some silty fines, wet	42.0			S-11 to S-14: Sampler refusal; possible coarse gravel / COBBLE S-11: Atterberg Limits ASTM D4318: LL = 17, PL = 10, PI = 7		
791.3	42											
790.3	43				CL	40-50/5"	CL	Gray lean CLAY; mostly clayey fines, few fine sand, trace fine gravel, moist	4.5+		9.3	
789.3	44											
788.3	45											
787.3	46	S-12	0.9	40-50/5"	CL	4.5+	8.9					
786.3	47											
785.3	48											
784.3	49											
783.3	50	S-13	0.9	36-50/5"	CL	4.5+	9.2					
782.3	51											
781.3	52											
780.3	53											
779.3	54											
778.3	55	S-14	1.2	22-48-50/2"	CL	4.5+	12.6					
777.3	56											
776.3	57											
775.3	58											
774.3	59											
773.3	60					60.0						
End of Boring												

* Visual estimate following ASTM D 2488 unless laboratory testing has been performed. Stratification changes are approximated between samples.



SUMMARY OF LABORATORY TEST DATA

Boring Number	Sample Number*	Depth (ft)	Sample Description and USCS Classification	Natural Moisture Content (ASTM D2216) (%)	Atterberg Limits (ASTM D4318)		
					LL	PL	PI
B-1	S-4	8.5-10	CL	11.7			
B-1	S-5	13.5-15	CL	8.3			
B-1	S-6	18.5-20	CL	7.6	24	14	10
B-1	S-8	28.5-30	CL	9.8			
B-1	S-10	38.5-40	CL	13.2			
B-1	S-11	43.5-45	CL	19.2			
B-1	S-13	53.5-55	CL	13.9			
B-1	S-14	58.5-60	CL	16.6			
B-2	S-1	0-1.5	CL	6.9			
B-2	S-2	3.5-5	CL	13.1			
B-2	S-3	6.0-7.5	CL	12.0			
B-2	S-5	13.5-15	CL	7.5			
B-2	S-6	18.5-20	CL	11.1			
B-2	S-7	23.5-25	CL	11.6	22	15	7
B-2	S-8	28.5-30	CL	8.7			
B-2	S-9	33.5-35	CL	10.5			
B-2	S-11	43.5-45	CL	15.4			
B-2	S-13	53.5-55	CL	17.4			
B-3	S-4	8.5-10	CL	18.3			
B-3	S-5	13.5-15	CL	11.0	20	11	9
B-3	S-11	43.5-45	CL	7.2	17	10	7
B-3	S-12	48.5-50	CL	11.0			
B-3	S-13	53.5-55	CL	11.8			
B-3	S-14	58.5-60	CL	10.3			
B-4	S-3	6.0-7.5	CL	14.8			
B-4	S-4	8.5-10	CL	18.5			
B-4	S-4	13.5-15	CL	15.7			
B-4	S-11	43.5-45	CL	9.3			
B-4	S-12	48.5-50	CL	8.9			
B-4	S-13	53.5-55	CL	9.2			
B-4	S-14	58.5-60	CL	12.6			

* S – Split Spoon Sample (ASTM D 1586)



**MICHIGAN DEPARTMENT OF ENVIRONMENT, GREAT LAKES, AND ENERGY
WATER RESOURCES DIVISION
PERMIT**

Issued To:

**City of Ann Arbor
Attn: Hillary Hanzel
301 East Huron
Ann Arbor, Michigan 48104**

**Permit No: WRP042267 v.1
Submission No.: HQ3-SJRQ-GYSGQ
Site Name: 81-2120 Traver Road-Ann Arbor
Issued: August 14, 2024
Revised:
Expires: August 14, 2029**

This permit is being issued by the Michigan Department of Environment, Great Lakes, and Energy (EGLE), Water Resources Division, under the provisions of the Natural Resources and Environmental Protection Act, 1994 PA 451, as amended (NREPA); specifically:

- | | |
|---|---|
| <input checked="" type="checkbox"/> Part 301, Inland Lakes and Streams | <input type="checkbox"/> Part 323, Shorelands Protection and Management |
| <input type="checkbox"/> Part 303, Wetlands Protection | <input type="checkbox"/> Part 325, Great Lakes Submerged Lands |
| <input type="checkbox"/> Part 315, Dam Safety | <input type="checkbox"/> Part 353, Sand Dunes Protection and Management |
| <input checked="" type="checkbox"/> Part 31, Water Resources Protection (Floodplain Regulatory Authority) | |

EGLE certifies that the activities authorized under this permit are in compliance with the State Coastal Zone Management Program and certifies without conditions under the Federal Clean Water Act, Section 401 that the discharge from the activities authorized under this permit will comply with Michigan's water quality requirements in Part 31, Water Resources Protection, of the NREPA and associated administrative rules, where applicable.

Permission is hereby granted, based on permittee assurance of adherence to State of Michigan requirements and permit conditions, to:

Authorized Activity:

Remove existing 10-foot-wide, 20-foot-long timber bridge from Traver Creek. Construct a 12-foot-wide, 30-foot-long steel bridge on Traver Creek. Excavate approximately 31 cubic yards of material from below the ordinary high-water mark and place approximately 3 cubic yards of riprap below the ordinary high-water mark of Traver Creek. Replacement of an existing timber pedestrian bridge on the Traver Creek with a new prefabricated steel bridge whose cross-sectional flow area is approximately 37 square feet larger than the existing crossing.

All work shall be completed in accordance with the approved plans and the specifications of this permit.

**EGLE
WRP042267 v1.0
Approved
Issued On:08/14/2024
Expires On:08/14/2029**

Waterbody Affected: Traver Creek
Property Location: Washtenaw County, City of Ann Arbor, Town 02S, Range 06E, Section 16,
Property Tax No. 09-09-16-400-008

Authority granted by this permit is subject to the following limitations:

- A. Initiation of any work on the permitted project confirms the permittee's acceptance and agreement to comply with all terms and conditions of this permit.
- B. The permittee, in exercising the authority granted by this permit, shall not cause unlawful pollution as defined by Part 31 of the NREPA.
- C. This permit shall be kept at the site of the work and available for inspection at all times during the duration of the project or until its date of expiration.
- D. All work shall be completed in accordance with the approved plans and specifications submitted with the application and/or plans and specifications attached to this permit.
- E. No attempt shall be made by the permittee to forbid the full and free use by the public of public waters at or adjacent to the structure or work approved.
- F. It is made a requirement of this permit that the permittee give notice to public utilities in accordance with 2013 PA 174 (Act 174) and comply with each of the requirements of Act 174.
- G. This permit does not convey property rights in either real estate or material, nor does it authorize any injury to private property or invasion of public or private rights, nor does it waive the necessity of seeking federal assent, all local permits, or complying with other state statutes.
- H. This permit does not prejudice or limit the right of a riparian owner or other person to institute proceedings in any circuit court of this state when necessary to protect his rights.
- I. Permittee shall notify EGLE within one week after the completion of the activity authorized by this permit by completing and forwarding the attached preaddressed postcard to the office addressed thereon.
- J. This permit shall not be assigned or transferred without the written approval of EGLE.
- K. Failure to comply with conditions of this permit may subject the permittee to revocation of permit and criminal and/or civil action as cited by the specific state act, federal act, and/or rule under which this permit is granted.
- L. All dredged or excavated materials shall be disposed of in an upland site (outside of floodplains, unless exempt under Part 31 of the NREPA, and wetlands).
- M. In issuing this permit, EGLE has relied on the information and data that the permittee has provided in connection with the submitted application for permit. If, subsequent to the issuance of a permit, such information and data prove to be false, incomplete, or inaccurate, EGLE may modify, revoke, or suspend the permit, in whole or in part, in accordance with the new information.
- N. The permittee shall indemnify and hold harmless the State of Michigan and its departments, agencies, officials, employees, agents, and representatives for any and all claims or causes of action arising from acts or omissions of the permittee, or employees, agents, or representative of the permittee, undertaken in connection with this permit. The permittee's obligation to indemnify the State of Michigan applies only if the state: (1) provides the permittee or its designated representative written notice of the claim or cause of action within 30 days after it is received by the state, and (2) consents to the permittee's participation in the proceeding on the claim or cause of action. It does not apply to contested case proceedings under the Administrative Procedures Act, 1969 PA 306, as amended, challenging the permit. This permit shall not be construed as an indemnity by the State of Michigan for the benefit of the permittee or any other person.

- O. Noncompliance with these terms and conditions and/or the initiation of other regulated activities not specifically authorized shall be cause for the modification, suspension, or revocation of this permit, in whole or in part. Further, EGLE may initiate criminal and/or civil proceedings as may be deemed necessary to correct project deficiencies, protect natural resource values, and secure compliance with statutes.
- P. If any change or deviation from the permitted activity becomes necessary, the permittee shall request, in writing, a revision of the permitted activity from EGLE. Such revision request shall include complete documentation supporting the modification and revised plans detailing the proposed modification. Proposed modifications must be approved, in writing, by EGLE prior to being implemented.
- Q. This permit may be transferred to another person upon written approval of EGLE. The permittee must submit a written request to EGLE to transfer the permit to the new owner. The new owner must also submit a written request to EGLE to accept transfer. The new owner must agree, in writing, to accept all conditions of the permit. A single letter signed by both parties that includes all the above information may be provided to EGLE. EGLE will review the request and, if approved, will provide written notification to the new owner.
- R. Prior to initiating permitted construction, the permittee is required to provide a copy of the permit to the contractor(s) for review. The property owner, contractor(s), and any agent involved in exercising the permit are held responsible to ensure that the project is constructed in accordance with all drawings and specifications. The contractor is required to provide a copy of the permit to all subcontractors doing work authorized by the permit.
- S. Construction must be undertaken and completed during the dry period of the wetland. If the area does not dry out, construction shall be done on equipment mats to prevent compaction of the soil.
- T. Authority granted by this permit does not waive permit requirements under Part 91, Soil Erosion and Sedimentation Control, of the NREPA, or the need to acquire applicable permits from the County Enforcing Agent (CEA).
- U. Authority granted by this permit does not waive permit requirements under the authority of Part 305, Natural Rivers, of the NREPA. A Natural Rivers Zoning Permit may be required for construction, land alteration, streambank stabilization, or vegetation removal along or near a natural river.
- V. The permittee is cautioned that grade changes resulting in increased runoff onto adjacent property is subject to civil damage litigation.
- W. Unless specifically stated in this permit, construction pads, haul roads, temporary structures, or other structural appurtenances to be placed in a wetland or on bottomland of the water body are not authorized and shall not be constructed unless authorized by a separate permit or permit revision granted in accordance with the applicable law.
- X. For projects with potential impacts to fish spawning or migration, no work shall occur within fish spawning or migration timelines (i.e., windows) unless otherwise approved in writing by the Michigan Department of Natural Resources, Fisheries Division.
- Y. Work to be done under authority of this permit is further subject to the following special instructions and specifications:
1. During removal or repair of the existing structure, every precaution shall be taken to prevent debris from entering any watercourse. Any debris reaching the watercourse during the removal and/or reconstruction of the structure shall be immediately retrieved from the water. All material shall be disposed of in an acceptable manner consistent with local, state, and federal regulations.

2. If the project, or any portion of the project, is stopped and lies incomplete for any length of time (other than that encountered in a normal work week) every precaution shall be taken to protect the incomplete work from erosion, including the placement of temporary gravel bag riprap, temporary seeding and mulching, or other acceptable temporary protection.
3. The placement of riprap shall be limited to the minimum necessary to ensure proper stabilization of the side slopes and fill in the immediate vicinity of the structure.
4. No work shall be done in the stream during periods of above-normal flows except as necessary to prevent erosion.
5. The permittee is hereby cautioned that any discharge of sediment into waters of the state is a violation of Part 31, Water Resources Protection, of the NREPA. Any sedimentation caused by the construction or use of the permitted structure subjects the permittee to provisions of Part 31.
6. All fill/backfill shall consist of clean inert material that will not cause siltation nor contain soluble chemicals, organic matter, pollutants, or contaminants. All fill shall be contained in such a manner so as not to erode into any surface water, floodplain, or wetland. All raw areas associated with the permitted activity shall be stabilized with sod and/or seed and mulch, riprap, or other technically effective methods as necessary to prevent erosion.
7. Prior to the removal of the existing structures, cofferdams of steel sheet piling, gravel bags, clean stone, coarse aggregate, concrete, or other acceptable barriers shall be installed to isolate all construction activity from the water. The barriers shall be maintained in good working order throughout the duration of the project. Upon project completion, the accumulated materials shall be removed and disposed of at an upland site.
8. All cofferdam and temporary steel sheet pile shall then be removed in its entirety, unless specifically shown to be left in place on the approved plans. Cofferdam and sheet pile that is left in place shall be cut off at the elevation shown on the plans and shall be a minimum of one foot below the stream bottom.
9. All slurry resulting from any dewatering operation shall be discharged through a filter bag or pumped to a sump located away from wetlands and surface waters and allowed to filter through natural upland vegetation, gravel filters, or other engineered devices for a sufficient distance and/or period of time necessary to remove sediment or suspended particles. The discharge of slurry water resulting from the hydrodemolition of concrete is not allowed to enter a lake, stream, or wetland.
10. The use of explosives for removal of structures over the waterbody, including any abutments or piers, is strictly prohibited.
11. The design flood or one percent (1%) annual chance (100-year) floodplain elevation at this location on the Traver Creek is 832.5 feet NAVD-88.
12. Any other filling, grading, or construction within the 100-year floodplain that is not specifically authorized by this permit will require a separate EGLE permit before starting the work.

13. The permittee is cautioned that grade changes resulting in increased runoff onto adjacent property is subject to civil damage litigation
14. Fill shall not be placed to prevent surface water drainage across the site. Site runoff shall be directed to public or natural drainage ways and not unnaturally discharged onto adjacent properties.
15. Authority granted by this permit does not waive permit or program requirements under Part 91, Soil Erosion and Sedimentation Control, of the NREPA or the need to acquire applicable permits from the CEA. To locate the Soil Erosion Program Administrator for your county, visit <https://www.michigan.gov/egle/about/organization/water-resources/soil-erosion/sesc-overview> and select "Soil Erosion and Sedimentation Control Agencies".
16. The authority to conduct the activity as authorized by this permit is granted solely under the provisions of the governing act as identified above. This permit does not convey, provide, or otherwise imply approval of any other governing act, ordinance, or regulation, nor does it waive the permittee's obligation to acquire any local, county, state, or federal approval or authorization necessary to conduct the activity.
17. No fill, excess soil, or other material shall be placed in any wetland, floodplain, or surface water area not specifically authorized by this permit, its plans, and specifications.
18. This permit does not authorize or sanction work that has been completed in violation of applicable federal, state, or local statutes.
19. The permit placard shall be kept posted at the work site in a prominent location at all times for the duration of the project or until permit expiration.
20. This permit is being issued for the maximum time allowed and no extensions of this permit will be granted. Initiation of the construction work authorized by this permit indicates the permittee's acceptance of this condition. The permit, when signed by EGLE, will be for a five-year period beginning on the date of issuance. If the project is not completed by the expiration date, a new permit must be sought.

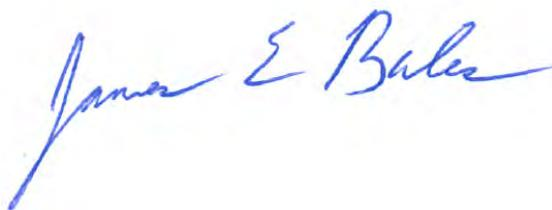

Issued By: _____

James Bales
Jackson District Office
Water Resources Division
517-257-4532

THIS PERMIT MUST BE SIGNED BY THE PERMITTEE TO BE VALID.

I hereby assure that I have read, am familiar with, and agree to adhere to the terms and conditions of this permit.

Permittee Signature

Date

cc: City of Ann Arbor Clerk
Cassandra Wagner, Stantec
Joshua Gleason, EGLE



NOTICE OF AUTHORIZATION

Permit Number: WRP042267 v. 1
Site Name: 81-2120 Traver Road-Ann Arbor

Date Issued: August 14, 2024
Expiration Date: August 14, 2029

The Michigan Department of Environment, Great Lakes, and Energy (EGLE), Water Resources Division, P.O. Box 30458, Lansing, Michigan 48909-7958, under provisions of the Natural Resources and Environmental Protection Act, 1994 PA 451, as amended; specifically:

- Part 31, Floodplain Regulatory Authority of the Water Resources Protection.
- Part 301, Inland Lakes and Streams.

Authorized activity:

Remove existing 10-foot-wide, 20-foot-long timber bridge from Traver Creek. Construct a 12-foot-wide, 30-foot-long steel bridge on Traver Creek. Excavate approximately 31 cubic yards of material from below the ordinary high-water mark and place approximately 3 cubic yards of riprap below the ordinary high-water mark of Traver Creek. Replacement of an existing timber pedestrian bridge on the Traver Creek with a new prefabricated steel bridge whose cross-sectional flow area is approximately 37 square feet larger than the existing crossing.

All work shall be completed in accordance with the approved plans and the specifications of this permit.

To be conducted at property located in: Washtenaw County, Waterbody: Traver Creek
Section 16, Town 02S, Range 06E, City of Ann Arbor

Permittee: City of Ann Arbor
Attn: Hillary Hanzel
301 East Huron
Ann Arbor, Michigan 48104

James Bales
Jackson District Office
Water Resources Division
517-257-4532

This notice must be displayed at the site of work.
Laminating this notice or utilizing sheet protectors is recommended.
Please refer to the above permit number with any questions or concerns.

EGLE
WRP042267 v1.0
Approved
Issued On:08/14/2024
Expires On:08/14/2029



**MICHIGAN DEPARTMENT OF ENVIRONMENT, GREAT LAKES, AND ENERGY
WATER RESOURCES DIVISION
PERMIT**

Issued To:

**City of Ann Arbor
Attn: Hillary Hanzel
301 East Huron
Ann Arbor, Michigan 48104**

**Permit No: WRP042132 v.1
Submission No.: HQ3-SMJC-ZDVP4
Site Name: 81-2600 Yost Blvd-Ann Arbor
Issued: July 30, 2024
Revised:
Expires: July 30, 2029**

This permit is being issued by the Michigan Department of Environment, Great Lakes, and Energy (EGLE), Water Resources Division, under the provisions of the Natural Resources and Environmental Protection Act, 1994 PA 451, as amended (NREPA); specifically:

- | | |
|--|--|
| <input checked="" type="checkbox"/> Part 301, Inland Lakes and Streams | <input type="checkbox"/> Part 323, Shorelands Protection and Management |
| <input type="checkbox"/> Part 303, Wetlands Protection | <input type="checkbox"/> Part 325, Great Lakes Submerged Lands |
| <input type="checkbox"/> Part 315, Dam Safety | <input type="checkbox"/> Part 353, Sand Dunes Protection and Management |
| <input checked="" type="checkbox"/> Part 31, Water Resources Protection (Floodplain Regulatory Authority) | |

EGLE certifies that the activities authorized under this permit are in compliance with the State Coastal Zone Management Program and certifies without conditions under the Federal Clean Water Act, Section 401 that the discharge from the activities authorized under this permit will comply with Michigan’s water quality requirements in Part 31, Water Resources Protection, of the NREPA and associated administrative rules, where applicable.

Permission is hereby granted, based on permittee assurance of adherence to State of Michigan requirements and permit conditions, to:

Authorized Activity:

Remove existing 5-foot-wide, 16-foot-long timber bridge from Swift Run Drain. Construct an 8-foot-wide, 22-foot-long steel bridge on Swift Run Drain. Excavate approximately 7 cubic yards of material from below the ordinary high-water mark and place approximately 2 cubic yards of riprap below the ordinary high-water mark of Swift Run Drain. Replacement of an existing pedestrian bridge on Swift Run Drain with a prefabricated bridge whose cross-sectional area will be 10 square feet larger than the existing bridge.

All work shall be completed in accordance with the approved plans and the specifications of this permit.

Waterbody Affected: Swift Run Drain
Property Location: Washtenaw County, City of Ann Arbor, Town 03S, Range 06E, Section 02,
Property Tax No. 09-12-02-408-071

Authority granted by this permit is subject to the following limitations:

- A. Initiation of any work on the permitted project confirms the permittee's acceptance and agreement to comply with all terms and conditions of this permit.
- B. The permittee, in exercising the authority granted by this permit, shall not cause unlawful pollution as defined by Part 31 of the NREPA.
- C. This permit shall be kept at the site of the work and available for inspection at all times during the duration of the project or until its date of expiration.
- D. All work shall be completed in accordance with the approved plans and specifications submitted with the application and/or plans and specifications attached to this permit.
- E. No attempt shall be made by the permittee to forbid the full and free use by the public of public waters at or adjacent to the structure or work approved.
- F. It is made a requirement of this permit that the permittee give notice to public utilities in accordance with 2013 PA 174 (Act 174) and comply with each of the requirements of Act 174.
- G. This permit does not convey property rights in either real estate or material, nor does it authorize any injury to private property or invasion of public or private rights, nor does it waive the necessity of seeking federal assent, all local permits, or complying with other state statutes.
- H. This permit does not prejudice or limit the right of a riparian owner or other person to institute proceedings in any circuit court of this state when necessary to protect his rights.
- I. Permittee shall notify EGLE within one week after the completion of the activity authorized by this permit by completing and forwarding the attached preaddressed postcard to the office addressed thereon.
- J. This permit shall not be assigned or transferred without the written approval of EGLE.
- K. Failure to comply with conditions of this permit may subject the permittee to revocation of permit and criminal and/or civil action as cited by the specific state act, federal act, and/or rule under which this permit is granted.
- L. All dredged or excavated materials shall be disposed of in an upland site (outside of floodplains, unless exempt under Part 31 of the NREPA, and wetlands).
- M. In issuing this permit, EGLE has relied on the information and data that the permittee has provided in connection with the submitted application for permit. If, subsequent to the issuance of a permit, such information and data prove to be false, incomplete, or inaccurate, EGLE may modify, revoke, or suspend the permit, in whole or in part, in accordance with the new information.
- N. The permittee shall indemnify and hold harmless the State of Michigan and its departments, agencies, officials, employees, agents, and representatives for any and all claims or causes of action arising from acts or omissions of the permittee, or employees, agents, or representative of the permittee, undertaken in connection with this permit. The permittee's obligation to indemnify the State of Michigan applies only if the state: (1) provides the permittee or its designated representative written notice of the claim or cause of action within 30 days after it is received by the state, and (2) consents to the permittee's participation in the proceeding on the claim or cause of action. It does not apply to contested case proceedings under the Administrative Procedures Act, 1969 PA 306, as amended, challenging the permit. This permit shall not be construed as an indemnity by the State of Michigan for the benefit of the permittee or any other person.

- O. Noncompliance with these terms and conditions and/or the initiation of other regulated activities not specifically authorized shall be cause for the modification, suspension, or revocation of this permit, in whole or in part. Further, EGLE may initiate criminal and/or civil proceedings as may be deemed necessary to correct project deficiencies, protect natural resource values, and secure compliance with statutes.
- P. If any change or deviation from the permitted activity becomes necessary, the permittee shall request, in writing, a revision of the permitted activity from EGLE. Such revision request shall include complete documentation supporting the modification and revised plans detailing the proposed modification. Proposed modifications must be approved, in writing, by EGLE prior to being implemented.
- Q. This permit may be transferred to another person upon written approval of EGLE. The permittee must submit a written request to EGLE to transfer the permit to the new owner. The new owner must also submit a written request to EGLE to accept transfer. The new owner must agree, in writing, to accept all conditions of the permit. A single letter signed by both parties that includes all the above information may be provided to EGLE. EGLE will review the request and, if approved, will provide written notification to the new owner.
- R. Prior to initiating permitted construction, the permittee is required to provide a copy of the permit to the contractor(s) for review. The property owner, contractor(s), and any agent involved in exercising the permit are held responsible to ensure that the project is constructed in accordance with all drawings and specifications. The contractor is required to provide a copy of the permit to all subcontractors doing work authorized by the permit.
- S. Construction must be undertaken and completed during the dry period of the wetland. If the area does not dry out, construction shall be done on equipment mats to prevent compaction of the soil.
- T. Authority granted by this permit does not waive permit requirements under Part 91, Soil Erosion and Sedimentation Control, of the NREPA, or the need to acquire applicable permits from the County Enforcing Agent (CEA).
- U. Authority granted by this permit does not waive permit requirements under the authority of Part 305, Natural Rivers, of the NREPA. A Natural Rivers Zoning Permit may be required for construction, land alteration, streambank stabilization, or vegetation removal along or near a natural river.
- V. The permittee is cautioned that grade changes resulting in increased runoff onto adjacent property is subject to civil damage litigation.
- W. Unless specifically stated in this permit, construction pads, haul roads, temporary structures, or other structural appurtenances to be placed in a wetland or on bottomland of the water body are not authorized and shall not be constructed unless authorized by a separate permit or permit revision granted in accordance with the applicable law.
- X. For projects with potential impacts to fish spawning or migration, no work shall occur within fish spawning or migration timelines (i.e., windows) unless otherwise approved in writing by the Michigan Department of Natural Resources, Fisheries Division.
- Y. Work to be done under authority of this permit is further subject to the following special instructions and specifications:
1. During removal or repair of the existing structure, every precaution shall be taken to prevent debris from entering any watercourse. Any debris reaching the watercourse during the removal and/or reconstruction of the structure shall be immediately retrieved from the water. All material shall be disposed of in an acceptable manner consistent with local, state, and federal regulations.

2. If the project, or any portion of the project, is stopped and lies incomplete for any length of time (other than that encountered in a normal work week) every precaution shall be taken to protect the incomplete work from erosion, including the placement of temporary gravel bag riprap, temporary seeding and mulching, or other acceptable temporary protection.
3. The placement of riprap shall be limited to the minimum necessary to ensure proper stabilization of the side slopes and fill in the immediate vicinity of the structure.
4. No work shall be done in the stream during periods of above-normal flows except as necessary to prevent erosion.
5. The permittee is hereby cautioned that any discharge of sediment into waters of the state is a violation of Part 31, Water Resources Protection, of the NREPA. Any sedimentation caused by the construction or use of the permitted structure subjects the permittee to provisions of Part 31.
6. All fill/backfill shall consist of clean inert material that will not cause siltation nor contain soluble chemicals, organic matter, pollutants, or contaminants. All fill shall be contained in such a manner so as not to erode into any surface water, floodplain, or wetland. All raw areas associated with the permitted activity shall be stabilized with sod and/or seed and mulch, riprap, or other technically effective methods as necessary to prevent erosion.
7. Prior to the removal of the existing structures, cofferdams of steel sheet piling, gravel bags, clean stone, coarse aggregate, concrete, or other acceptable barriers shall be installed to isolate all construction activity from the water. The barriers shall be maintained in good working order throughout the duration of the project. Upon project completion, the accumulated materials shall be removed and disposed of at an upland site.
8. All cofferdam and temporary steel sheet pile shall then be removed in its entirety, unless specifically shown to be left in place on the approved plans. Cofferdam and sheet pile that is left in place shall be cut off at the elevation shown on the plans and shall be a minimum of one foot below the stream bottom.
9. All slurry resulting from any dewatering operation shall be discharged through a filter bag or pumped to a sump located away from wetlands and surface waters and allowed to filter through natural upland vegetation, gravel filters, or other engineered devices for a sufficient distance and/or period of time necessary to remove sediment or suspended particles. The discharge of slurry water resulting from the hydrodemolition of concrete is not allowed to enter a lake, stream, or wetland.
10. The use of explosives for removal of structures over the waterbody, including any abutments or piers, is strictly prohibited.
11. The design flood or one percent (1%) annual chance (100-year) floodplain elevation at this location on the Swift Run Drain is 797 feet NAVD-88.

12. Any other filling, grading, or construction within the 100-year floodplain that is not specifically authorized by this permit will require a separate EGLE permit before starting the work.
13. The permittee is cautioned that grade changes resulting in increased runoff onto adjacent property is subject to civil damage litigation.
14. Fill shall not be placed to prevent surface water drainage across the site. Site runoff shall be directed to public or natural drainage ways and not unnaturally discharged onto adjacent properties.
15. Authority granted by this permit does not waive permit or program requirements under Part 91, Soil Erosion and Sedimentation Control, of the NREPA or the need to acquire applicable permits from the CEA. To locate the Soil Erosion Program Administrator for your county, visit <https://www.michigan.gov/egle/about/organization/water-resources/soil-erosion/sesc-overview> and select "Soil Erosion and Sedimentation Control Agencies".
16. The authority to conduct the activity as authorized by this permit is granted solely under the provisions of the governing act as identified above. This permit does not convey, provide, or otherwise imply approval of any other governing act, ordinance, or regulation, nor does it waive the permittee's obligation to acquire any local, county, state, or federal approval or authorization necessary to conduct the activity.
17. No fill, excess soil, or other material shall be placed in any wetland, floodplain, or surface water area not specifically authorized by this permit, its plans, and specifications.
18. This permit does not authorize or sanction work that has been completed in violation of applicable federal, state, or local statutes.
19. The permit placard shall be kept posted at the work site in a prominent location at all times for the duration of the project or until permit expiration.
20. This permit is being issued for the maximum time allowed and no extensions of this permit will be granted. Initiation of the construction work authorized by this permit indicates the permittee's acceptance of this condition. The permit, when signed by EGLE, will be for a five-year period beginning on the date of issuance. If the project is not completed by the expiration date, a new permit must be sought.

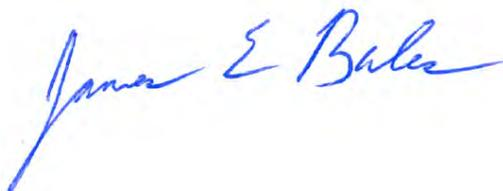

Issued By: _____

James Bales
Jackson District Office
Water Resources Division
517-257-4532

EGLE
WRP042132 v1.0
Approved
Issued On:07/30/2024
Expires On:07/30/2029

THIS PERMIT MUST BE SIGNED BY THE PERMITTEE TO BE VALID.

I hereby assure that I have read, am familiar with, and agree to adhere to the terms and conditions of this permit.

Permittee Signature

Date

cc: City of Ann Arbor Clerk
Cassandra Wagner, Stantec
Joshua Gleason, EGLE



NOTICE OF AUTHORIZATION

Permit Number: WRP042132 v. 1
Site Name: 81-2600 Yost Blvd-Ann Arbor

Date Issued: July 30, 2024
Expiration Date: July 30, 2029

The Michigan Department of Environment, Great Lakes, and Energy (EGLE), Water Resources Division, P.O. Box 30458, Lansing, Michigan 48909-7958, under provisions of the Natural Resources and Environmental Protection Act, 1994 PA 451, as amended; specifically:

- Part 31, Floodplain Regulatory Authority of the Water Resources Protection.
- Part 301, Inland Lakes and Streams.

Authorized activity:

Remove existing 5-foot-wide, 16-foot-long timber bridge from Swift Run Drain. Construct an 8-foot-wide, 22-foot-long steel bridge on Swift Run Drain. Excavate approximately 7 cubic yards of material from below the ordinary high-water mark and place approximately 2 cubic yards of riprap below the ordinary high-water mark of Swift Run Drain. Replacement of an existing pedestrian bridge on Swift Run Drain with a prefabricated bridge whose cross-sectional area will be 10 square feet larger than the existing bridge.

All work shall be completed in accordance with the approved plans and the specifications of this permit.

To be conducted at property located in: Washtenaw County, Waterbody: Swift Run Drain
Section 02, Town 03S, Range 06E, City of Ann Arbor

Permittee: City of Ann Arbor
Attn: Hillary Hanzel
301 East Huron
Ann Arbor, Michigan 48104

James Bales
Jackson District Office
Water Resources Division
517-257-4532

*This notice must be displayed at the site of work.
Laminating this notice or utilizing sheet protectors is recommended.*
Please refer to the above permit number with any questions or concerns.

EGLE
WRP042132 v1.0
Approved
Issued On:07/30/2024
Expires On:07/30/2029



CITY OF ANN ARBOR

LESLIE PARK AND SYLVAN PARK BRIDGE REPLACEMENTS

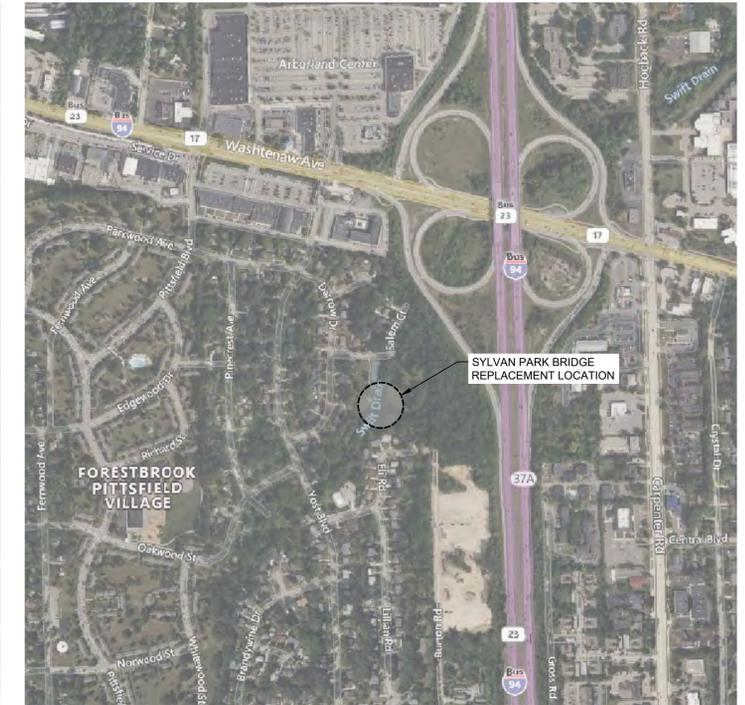

PROJECT LOCATION MAP
NOT TO SCALE

GENERAL SHEETS

G-001	01	COVER SHEET
G-002	02	GENERAL NOTES, LEGEND, AND SYMBOLS
G-003	03	SOIL EROSION CONTROL AND CONSTRUCTION DETAILS

CIVIL SHEETS

C-100	04	LESLIE PARK BRIDGE - EX. COND, DEMO, SESC & CONSTRUCTION PLAN
C-101	05	CONTECH BRIDGE DETAILS - LESLIE PARK BRIDGE
C-102	06	CONTECH BRIDGE DETAILS - LESLIE PARK BRIDGE
C-103	07	LESLIE PARK BRIDGE - ABUTMENT DETAILS
C-104	08	SYLVAN PARK BRIDGE - EX. COND, DEMO, SESC & CONSTRUCTION PLAN
C-105	09	SYLVAN PARK BRIDGE - ABUTMENT DETAILS
C-200	10	LESLIE PARK BRIDGE - & SYLVAN PARK BRIDGE - STAGING PLAN

ADDENDUM #1
SEPTEMBER, 2024
PROJECT NUMBER: 2075153906

CONSTRUCTION NOTES

- PRE-CONSTRUCTION MEETING
A PRE-CONSTRUCTION MEETING SHALL BE HELD PRIOR TO ANY WORK BEING PERFORMED ON THE PROJECT. THE MEETING TIME, PLACE, AND ATTENDEES SHALL BE ARRANGED BY THE PROJECT ENGINEER. ANN ARBOR PARKS & RECREATION SHALL BE INVITED, AT A MINIMUM TO THE PRE-CONSTRUCTION MEETING.
- SHOP DRAWINGS AND MATERIAL CERTIFICATES
PRIOR TO THE START OF CONSTRUCTION THE CONTRACTOR SHALL FURNISH MATERIAL SOURCE LISTS AND CERTIFICATIONS TO THE PROJECT ENGINEER, VERIFYING THAT ALL MATERIALS USED ON THE PROJECT ARE IN ACCORDANCE WITH MICHIGAN DEPARTMENT OF TRANSPORTATION 2020 STANDARD SPECIFICATIONS FOR CONSTRUCTION. SHOP DRAWINGS SHALL BE REQUIRED FOR MAJOR MATERIALS.
- MISS DIG UTILITY ALERT AND FIELD LOCATION OF UTILITIES
THREE (3) WORKING DAYS PRIOR TO BEGINNING CONSTRUCTION, IT SHALL BE THE CONTRACTOR'S RESPONSIBILITY TO CONTACT MISS DIG UTILITY PROTECTION SERVICE (811) TO VERIFY THE LOCATION OF ALL EXISTING UTILITIES. UNDERGROUND UTILITY LOCATIONS AS SHOWN ON THE PLANS WERE OBTAINED FROM UTILITY OWNERS AND WERE NOT FIELD LOCATED. THE CONTRACTOR SHALL ASSUME RESPONSIBILITY FOR THE PROTECTION OF ALL EXISTING UTILITIES DURING CONSTRUCTION. ALL UTILITIES DAMAGED DURING CONSTRUCTION SHALL BE REPAIRED WITH LIKE MATERIAL IN ACCORDANCE WITH THE UTILITY OWNERS' REQUIREMENTS. THE CONTRACTOR SHALL VERIFY THE DEPTH AND HORIZONTAL LOCATION OF ALL EXISTING UTILITIES. THE EXACT LOCATION OF EXISTING UTILITIES SHALL BE DETERMINED BY HAND DIGGING.
- UTILITY INFORMATION
PUBLIC UTILITY INFORMATION IS DELINEATED IN ACCORDANCE WITH LOCATIONS PROVIDED BY UTILITY OWNERS. THE DESIGN ENGINEER IS NOT RESPONSIBLE FOR THE ACCURACY OF THE INFORMATION OR THE LOCATION AT WHICH THESE SERVICES EXIST. DIFFERING FIELD CONDITIONS SHALL BE BROUGHT TO THE ATTENTION OF THE ENGINEER.
THE LOCATION OF ALL PUBLIC UTILITIES SHOWN ON THE PLANS ARE TAKEN FROM THE BEST AVAILABLE DATA. THE OWNER WILL NOT BE RESPONSIBLE FOR ANY OMISSION OR VARIATIONS FROM THE LOCATIONS SHOWN.
CONSTRUCTION OPERATIONS SHALL BE CONDUCTED IN A MANNER AS TO INSURE THAT THOSE UTILITIES NOT REQUIRING RELOCATION WILL NOT BE DISTURBED. REPAIRS OF UTILITIES DAMAGED DURING CONSTRUCTION BY THE CONTRACTOR SHALL BE THE FULL RESPONSIBILITY OF THE CONTRACTOR IN ACCORDANCE WITH THE AFFECTED UTILITY OWNERS' REQUIREMENTS.
ALL PRIVATE UTILITY STRUCTURES WILL BE ADJUSTED TO GRADE BY THE OWNER OF THE FACILITY. THE CONTRACTOR SHALL PROVIDE THE ENGINEER WITH THREE (3) WORKING DAYS NOTICE PRIOR TO THE START OF SUCH WORK.
- STORMWATER DRAINAGE DURING CONSTRUCTION
THE CONTRACTOR SHALL MAINTAIN DITCH DRAINAGE DURING CONSTRUCTION AND SHALL NOT OBSTRUCT SUMP PUMP LEADS DISCHARGING TO THE DITCH. THE CONTRACTOR SHALL TAKE ALL NECESSARY MEASURES TO PROTECT ALL STORM SEWER FACILITIES SUCH AS CATCH BASINS, CULVERTS AND HEADWALLS DURING CONSTRUCTION. CULVERTS AND CATCH BASINS CONTAMINATED DURING CONSTRUCTION SHALL BE CLEANED AND THE COSTS SHALL BE INCLUDED IN THE EROSION CONTROL AND PROJECT CLEAN UP PAY ITEMS.
- CULVERTS
CONTRACTOR TO MARK ALL CULVERT LOCATIONS PRIOR TO CONSTRUCTION. CONTRACTOR TO VERIFY WITH ANN ARBOR PARKS & RECREATION THAT NO CULVERTS WERE DAMAGED DURING CONSTRUCTION. ALL CULVERT EXTENSIONS SHALL MATCH EXISTING SIZE AND CULVERT MATERIAL. RIP-RAP SHALL BE PLACED AT CULVERTS WITH HIGH FLOWS. QUANTITY SHALL BE DETERMINED BY THE ENGINEER.
- EXISTING UTILITIES
THE CONTRACTOR SHALL MAINTAIN ALL EXISTING SANITARY SEWER, WATER OR STORM SEWER SERVICE CONNECTIONS IN SERVICE THROUGHOUT THE CONSTRUCTION PERIOD. THE CONTRACTOR SHALL PROVIDE OR ARRANGE FOR TEMPORARY SUPPORT OF GAS MAIN AND UTILITY POLES WHERE NEEDED. ALL STORM SEWERS DAMAGED OR RELOCATED BY THE CONTRACTOR SHALL BE REPLACED WITH THE SAME SIZE AND QUALITY PIPE BY THE CONTRACTOR AT NO ADDITIONAL COST TO THE PROJECT. ALL UTILITIES UNDERMINED BY THE EXCAVATION SHALL HAVE COMPACTED CLASS II SAND BACKFILL PLACED UNDER THEM.
- UTILITY COORDINATION
COORDINATION OF RELOCATED UTILITIES WILL BE PERFORMED AND COMPLETED PRIOR TO INSTALLATION OF THE PATH. FOR UTILITIES THAT NEED TO BE RELOCATED DURING CONSTRUCTION, THE CONTRACTOR WILL COORDINATE WITH THE RESPECTIVE UTILITY OWNER TO COMPLETE THIS TASK. THE COST TO RELOCATE UTILITIES WILL BE PAID FOR BY OTHERS. NO ADDITIONAL COST FOR COORDINATION EFFORTS INCURRED BY THE CONTRACTOR WILL BE PROVIDED.
- PROTECTION OF HAZARDOUS AREAS / OPEN EXCAVATIONS
EXCAVATIONS AND HAZARDOUS AREAS SHALL BE PROTECTED BY BARRICADES OR SNOW FENCE. THE PLACEMENT OF PROTECTIVE FENCING MEETING MICHIGAN STANDARDS IS REQUIRED AROUND ALL OPEN EXCAVATIONS, PAID FOR AS: FENCE, PROTECTIVE.
- DISPOSAL OF EXCESS EXCAVATED MATERIAL
ALL EXCESS EXCAVATED MATERIALS SHALL BE LEGALLY DISPOSED OF BY THE CONTRACTOR AT A LOCATION PROVIDED BY THE CONTRACTOR. ADJACENT PROPERTY OWNERS SHALL BE GIVEN PREFERENCE FOR DISPOSAL SITES.
- SALVAGED MATERIALS
SALVAGEABLE MATERIALS SHALL BECOME THE PROPERTY OF THE OWNER, AND SHALL BE STORED AS DIRECTED BY THE ENGINEER.
- SIGNS
ALL ANN ARBOR PARKS & RECREATION SIGNS RELOCATED BY CONSTRUCTION SHALL BE REPLACED, RELOCATED OR SALVAGED. SIGNS AND POSTS REMOVED SHALL BE DISPOSED OF BY THE CONTRACTOR.
- REMOVING PAVEMENT AND HMA SURFACES
THIS PROJECT INCLUDES PAVEMENT REMOVED OR MODIFIED AS BASIS OF PAYMENT FOR REMOVING EXISTING HOT MIX ASPHALT (HMA), CONCRETE, AND/OR MASONRY PAVEMENTS WITHIN THE CONSTRUCTION LIMITS. THE INFORMATION SHOWN ON THE PLANS AND THE QUANTITY FOR EACH OF THESE ITEMS IS APPROXIMATE AND BASED ON FIELD TESTS AND/OR HISTORICAL RECORDS. ACTUAL PAYMENT WILL BE BASED ON FIELD MEASUREMENTS IN ACCORDANCE WITH THE MICHIGAN DEPARTMENT OF TRANSPORTATION 2020 STANDARD SPECIFICATIONS FOR CONSTRUCTION.
- SAW CUTS
ALL SAW CUTS SHOWN ON THE PLANS OR AS SPECIFIED WILL NOT BE PAID FOR SEPARATELY, BUT WILL BE CONSIDERED AS HAVING BEEN INCLUDED IN THE CONTRACT UNIT PRICE BID FOR PAVEMENT OR CURB REMOVAL.
- GRADING LIMITS
THE GRADING/CLEARING LIMIT LINES SHOWN ON THE PLANS ARE GENERAL LIMITS PROVIDED IN ADDITION TO THE PATH PROFILE TO GUIDE THE CONTRACTOR IN ESTIMATING DISTURBANCE AREAS, AS WELL AS EXCAVATION AND EMBANKMENT. AREAS TO BE GRADED MAY EXTEND PAST THESE LIMITS WHEN WITHIN THE PUBLIC RIGHT-OF-WAY OR WITHIN DESIGNATED PATHWAY EASEMENTS AS APPROVED BY THE ENGINEER. THE CONTRACTOR SHALL ESTIMATE RESTORATION IMPACTS BASED ON THEIR ANALYSIS OF THE INFORMATION PROVIDED, AND NOT NECESSARILY THE GRADING LIMIT LINES SHOWN ON THE PLANS, AND SHALL BE RESPONSIBLE FOR PROVIDING ALL SITE RESTORATION FOR A SQUARE YARD AMOUNT AS PROVIDED IN TURF ESTABLISHMENT, PERFORMANCE AND PROJECT CLEAN UP PAY ITEMS. DISTURBANCE LIMITS SHALL BE MINIMIZED TO PROTECT ALL NATURAL AREAS. ALL DISTURBED AREAS SHALL BE RESTORED AS NEW.
- COVERS AND CASTINGS
ALL FINAL ELEVATIONS OF MANHOLE CASTINGS, HYDRANTS, VALVES AND VALVE BOXES SHALL BE DETERMINED BY THE ENGINEER IN THE FIELD. CASTINGS DAMAGED BY THE CONTRACTOR SHALL BE REPLACED AT THE EXPENSE OF THE CONTRACTOR, WITH MATERIALS APPROVED BY THE ENGINEER.
- TURF ESTABLISHMENT
ALL AREAS OF SLOPE RESTORATION SHALL BE SEEDDED WITH MDOY TYPE TURF (TURF URBAN FREEWAY) SEED MIXTURE. AT AREAS OF EROSION SOILS AND SLOPES, THE SEEDING MIXTURE SHALL CONTAIN ADDITIONAL CEREAL RYE WITHIN THE SEED MIXTURE FOR FASTER GROWTH POTENTIAL.
- RIPRAP, PLAIN
RIPRAP MATERIAL SHALL BE NATURAL STONE AS SPECIFIED IN SECTION 916.01 OF THE MDOY 2020 STANDARD SPECIFICATIONS FOR CONSTRUCTION.
- SUBBASE
THE CONTRACTOR SHALL PROVIDE A SAMPLE OF PATHWAY SUBBASE FOR TESTER TO CALIBRATE NIKE GAUGE.

BID ITEM QUANTITY TABLE (MISC. QUANTITIES):

ITEM NUMBER	ITEM DESCRIPTION	UNIT	TOTAL EST. QTY.
150001	GENERAL CONDITIONS AND MOBILIZATION (10% MAX)	LUMP SUM	1.0
2080036	EROSION CONTROL, SILT FENCE	FT	500.0
2090001	PROJECT CLEANUP	LUMP SUM	1.0
2097051	_AUDIO VISUAL FILE, SPECIAL	LUMP SUM	1.0
8080007	FENCE, PROTECTIVE	FT	100.0
8120026	PEDESTRIAN TYPE II BARRICADE, TEMP	EACH	4.0
8167002	_TURF ESTABLISHMENT, PERFORMANCE	SYD	250.0

GENERAL SITE NOTES

- THE WORK COVERED BY THESE PLANS INCLUDES BRIDGE REMOVAL, FOUNDATION EXCAVATION, ABUTMENT BACKFILL, ABUTMENT CONSTRUCTION, FURNISHING AND INSTALLATION PREFABRICATED STRUCTURE AND RELATED WORK.
- THE CONTRACTOR SHALL LOCATE ALL ACTIVE UNDERGROUND UTILITIES PRIOR TO STARTING WORK AND SHALL CONDUCT HIS OPERATIONS IN SUCH A MANNER AS TO ENSURE THAT THOSE UTILITIES NOT REQUIRING RELOCATION WILL NOT BE DISTURBED.
- PLANS REFER TO NAVD 88 DATUM.
- WATER LEVEL IS SUBJECT TO CHANGE. THE CONTRACTOR IS RESPONSIBLE FOR MAKING A DETERMINATION OF WATER LEVELS THAT MAY EXIST DURING CONSTRUCTION.
- MEASURES SHALL BE TAKEN TO PREVENT DEBRIS FROM FALLING FROM THE STRUCTURE. IF DEBRIS FALLS INTO THE WATERWAY, IT SHALL BE REMOVED WITHIN 24 HOURS. SINCE DISTURBANCE OF THE WATERWAY BOTTOM MAY BE AS HARMFUL AS THE DEBRIS ITSELF THE PREVENTATIVE MEASURES MUST BE EFFECTIVE.
- IMMEDIATELY AFTER THE CONSTRUCTION OF AN ABUTMENT IS COMPLETED, SLOPE PROTECTIONS AND SEEDING OR SODDING SHALL BE PLACED ON THE ADJACENT EMBANKMENT SLOPES.

GENERAL BRIDGE NOTES

- DESIGN AND CONSTRUCTION OF ALL WORK SHALL CONFORM TO THE PLANS AND SPECIFICATIONS PROVIDED AND APPLICABLE LOCAL AND STATE CODES, ORDINANCES, AND REGULATIONS INCLUDING THOSE OF THE COUNTY BUILDING DEPARTMENT.
- DO NOT SCALE THIS DRAWING. USE APPROVED PLANS FOR DIMENSIONS.
- PROPOSED SCOPE OF WORK IS TO DESIGN THE FOUNDATION FOR THE PROPOSED BRIDGES AS SHOWN ON THIS PLAN. THE REST OF THE STRUCTURE SHALL BE ADEQUATELY DESIGNED BY OTHERS.
- LOADING INFORMATION IS TAKEN FROM DRAWING PROVIDED BY THE BRIDGE MANUFACTURER. THE ENGINEER MUST BE NOTIFIED OF FINAL LOADING DURING SHOP DRAWINGS REVIEW.
- USE GRADE 60,000 PSI STEEL, EPOXY COATED.
- USE CONCRETE MIX WITH $f_c = 4,000$ PSI (CONC. CUBE STRENGTH).
- CLEAR DISTANCE BETWEEN PARALLEL BARS IN A LAYER SHALL BE NOT LESS THAN A BAR DIAMETER NOR 1".
- MINIMUM OVERLAP LENGTH OF THE REINFORCEMENT SHALL BE 2'.
- ALL REINFORCING DETAILS SHALL BE AS SHOWN IN APPROPRIATE SECTION OF THESE DRAWINGS UNLESS OTHERWISE SPECIFIED.
- CONCRETE MIX SHALL BE COMPACTED (VIBRATED) CONTINUOUSLY WHILE POURING CONCRETE.
- FORM AND REINFORCEMENTS SHALL BE ERRECTED PER SPECIFICATIONS SO THE FINISHED SMOOTH SURFACE SHALL BE ACHIEVED.
- WHEN CONCRETE IS PLACED AGAINST PREVIOUSLY HARDENED CONCRETE, THE INTERFACE SHALL BE ROUGHENED TO A FULL AMPLITUDE OF APPROXIMATELY 1/4".
- AT THE ASSUMED ELEVATION, IE @ THE FOUNDATION LEVEL, GROUND SHALL BE THOROUGHLY COMPACTED BEFORE POURING CONCRETE TO ACHIEVE A MAXIMUM DENSITY (OR AS DIRECTED BY ENGINEER).
- AT THE BOTTOM OF THE FOOTING, SIX INCHES OF CRUSHED STONE SHALL BE PLACED TO CREATE WORKING CONDITIONS. THE TRENCHES SHALL BE KEPT DRY DURING CONSTRUCTION.
- ALL CONCRETE WORK SHALL CONFORM TO ACI 301-72.
- ALL STRUCTURE REINFORCEMENT SHALL CONFORM TO ASTM-A615-60.
- WHILE POURING CONCRETE, THE AREA SHALL KEPT DRY, IE NEEDS TO BE DEWATERED BY WELL POINTS OR EQUIVALENT METHOD, IF POSSIBLE.
- FORMS FOR THE WALLS SHALL BE KEPT IN PLACE FOR AT LEAST 7 DAYS AFTER POURING THE CONCRETE.
- ANY DEVIATION FROM THE NOTED/DISCUSSED SUB-SURFACE CONDITIONS ENCOUNTERED DURING CONSTRUCTION, THEY SHALL BE BROUGHT TO THE ENGINEER'S ATTENTION IMMEDIATELY.
- IT IS TO BE NOTED THAT IN CASE OF DEEP EXCAVATION, SHORING AND BRACING OF THE TRENCHES SHALL BE REQUIRED BY OSHA CODES.
- MATERIALS REMOVED FROM THE EXCAVATION SHALL NOT BE STOCKPILED IMMEDIATELY ADJACENT TO THE EXCAVATION TO PREVENT SUDDEN COLLAPSE OF THE EMBANKMENT.
- THE EXCAVATION WIDTH OF TRENCHES FOR THE FOOTING SHALL BE AS REQUIRED FOR PROPER CONSTRUCTION.

LEGEND			
SYMBOL	DESCRIPTION	SYMBOL	DESCRIPTION
	EXIST. CONTOUR		EXIST. CURB AND GUTTER
	PROP. CONTOUR		PROP. CURB AND GUTTER
	EXIST. SPOT ELEVATION		CENTERLINE OF DITCH
	PROP. SPOT ELEVATION		EDGE OF WATER
	TOP OF CURB		EDGE OF WETLAND
	TOP OF PAVEMENT		EXISTING FENCE
	GUTTER		PROPOSED FENCE
	EXIST. STORM SEWER		TREE PROTECTION FENCE
	PROP. STORM SEWER		SILT FENCE
	EXIST. MANHOLE		CLEARING LIMITS
	PROP. MANHOLE		EXIST. GUARDRAIL
	PROP. EDGE DRAIN		PROP. GUARDRAIL
	EXIST. CATCH BASIN/INLET		PROPERTY LINE
	PROP. CATCH BASIN/INLET		CENTERLINE
	CULVERT		EXIST. SIGN
	INLET FILTER		PROP. SIGN
	PROP. CLEANOUT		ENCLOSED TRASH AREA
	EXIST. SANITARY SEWER		DRAINAGE DIRECTION
	PROP. SANITARY SEWER		SIDEWALK RAMP
	EXIST. WATER MAIN		BARRIER FREE PARKING
	PROP. WATER MAIN		FINISH FLOOR ELEV.
	EXIST. HYDRANT		BASEMENT FLOOR ELEV.
	PROP. HYDRANT		GARAGE FLOOR ELEV.
	EXIST. POST INDICATOR VALVE		SECTION CORNER
	EXIST. GATE VALVE AND BOX/STOP BOX		CONTROL POINT
	PROP. CURB STOP BOX		FOUND IRON PIPE
	EXIST. GATE VALVE AND WELL		SET IRON PIPE
	PROP. GATE VALVE AND WELL		FOUND CONCRETE MONUMENT
	PROP. REDUCER		SET CONCRETE MONUMENT
	PROP. END CAP		FOUND PK NAIL
	EXIST. OVERHEAD ELECTRIC		SET PK NAIL
	PROP. OVERHEAD ELECTRIC		FOUND LEADED CHISEL HOLE
	EXIST. UNDERGROUND ELECTRIC		SET LEADED CHISEL HOLE
	PROP. UNDERGROUND ELECTRIC		FOUND REROD
	EXIST. LIGHT POLE		APPROX. LOCATION OF SOIL BORING
	PROP. LIGHT POLE		APPROX. LOCATION OF MONITORING WELL
	EXIST. UTILITY POLE		APPROX. LOCATION OF PENETRATION TEST
	GUY WIRE		EXIST. DECIDUOUS TREE
	EXIST. ELECTRIC TRANSFORMER		EXIST. EVERGREEN TREE
	PROP. ELECTRIC TRANSFORMER		EXIST. SHRUB
	EXIST. OVERHEAD TELEPHONE		EXIST. TREE OR BRUSH LIMIT
	PROP. OVERHEAD TELEPHONE		TREE TO BE REMOVED
	EXIST. UNDERGROUND TELEPHONE		REMOVE AND REPLACE
	PROP. UNDERGROUND TELEPHONE		BITUMINOUS PAVEMENT
	EXIST. GAS		GRAVEL PAVEMENT
	PROP. GAS		CONCRETE PAVEMENT
	EXIST. MAILBOX		BRICK PAVERS
	EXIST. GAS RISER		
	EXIST. TELEPHONE RISER		
	COMPACTED SAND BACKFILL		

STANDARD PLANS NOT TO BE PRINTED	
SHEET NO.	TITLE
R-28-J	CURB RAMP AND DETECTABLE WARNING DETAILS
R-29-I	DRIVEWAY OPENINGS & APPROACHES, AND CONCRETE SIDEWALKS
R-82-D	BEDDING AND FILLING AROUND PIPE CULVERTS
R-83-C	UTILITY TRENCHES
R-86-F	PRECAST CONCRETE END SECTION FOR PIPE CULVERTS
R-95-G	CULVERT SLOPED END SECTIONS
R-96-E	SOIL EROSION & SEDIMENTATION CONTROL MEASURES
R-100-H*	SEEDING AND TREE PLANTING
R-1-G	DRAINAGE STRUCTURES
R-35-E	CONCRETE SHOULDER GUTTER & SPILLWAY

*DENOTES SPECIAL DETAIL INCLUDED IN PROPOSAL.

TRAFFIC AND SAFETY STANDARD PLANS NOT TO BE PRINTED	
SHEET NO.	TITLE
*WZD-100-A	GROUND DRIVEN SIGN SUPPORTS FOR TEMP SIGNS
*WZD-125-E	TEMPORARY TRAFFIC CONTROL DEVICES
SIGN-120-E	ROADSIDE SIGN LOCATIONS & SUPPORT SPACING
SIGN-200-E	STEEL POSTS
PAVE-900-G	PAVEMENT ARROW AND MESSAGE DETAILS
PAVE-945-D	INTERSECTION, STOP BAR & CROSSWALK MARKINGS
SIGN-740-B	MISCELLANEOUS SIGN CONNECTION DETAILS

AGENCY & UTILITY CONTACTS

CITY OF ANN ARBOR PARKS & RECREATION
 HILLARY HANZEL
 PARK PLANNER & LANDSCAPE ARCHITECT
 301 E. HURON STREET
 ANN ARBOR, MI 48104
 (734) 794-6230 EXT. 42548
 Email: hh-hanzel@aagov.org



Stantec Consulting Michigan Inc.
 3754 Ranchero Drive
 Ann Arbor MI 48108-2771
 Tel: (734) 761-1010
 www.stantec.com

Copyright Reserved

The Contractor shall verify and be responsible for all dimensions. DO NOT scale the drawing - any errors or omissions shall be reported to Stantec without delay. The Copyrights to all designs and drawings are the property of Stantec. Reproduction or use for any purpose other than that authorized by Stantec is forbidden.

Notes

E	ADDENDUM #1	CW	MP	2024.09.24
D	BID SET	CW	MP	2024.08.16
C	PERMIT SET	CW	MP	2024.05.15
B	REVIEW SET	CW	MP	2024.03.15
A	PRELIMINARY PLANS	CW	MP	2023.11.10
Issued				By Appd YYYY.MM.DD
File Name: 153706_G-002				JA CW MP 2023.11.09
				Dwn. Dgrn. Chkd. YYYY.MM.DD

Permit/Seal

Client/Project
 CITY OF ANN ARBOR

ANN ARBOR PARKS
 BRIDGE REPLACEMENT

Ann Arbor, MI

GENERAL NOTES, LEGEND AND
 SYMBOLS

Project No. 2075153906 Scale:

Revision Sheet 0 02 of 10 Drawing No.

G-002



NOTE:
 THE LOCATIONS AND ELEVATIONS OF EXISTING UNDERGROUND UTILITIES AS SHOWN ON THIS DRAWING ARE ONLY APPROXIMATE. NO GUARANTEE IS EITHER EXPRESSED OR IMPLIED AS TO THE COMPLETENESS OR ACCURACY THEREOF. THE CONTRACTOR SHALL BE RESPONSIBLE FOR CONTACTING MISS DIG PRIOR TO CONSTRUCTION.

Copyright Reserved

The Contractor shall verify and be responsible for all dimensions. DO NOT scale the drawing - any errors or omissions shall be reported to Stantec without delay.
The Copyrights to all designs and drawings are the property of Stantec. Reproduction or use for any purpose other than that authorized by Stantec is forbidden.

Notes

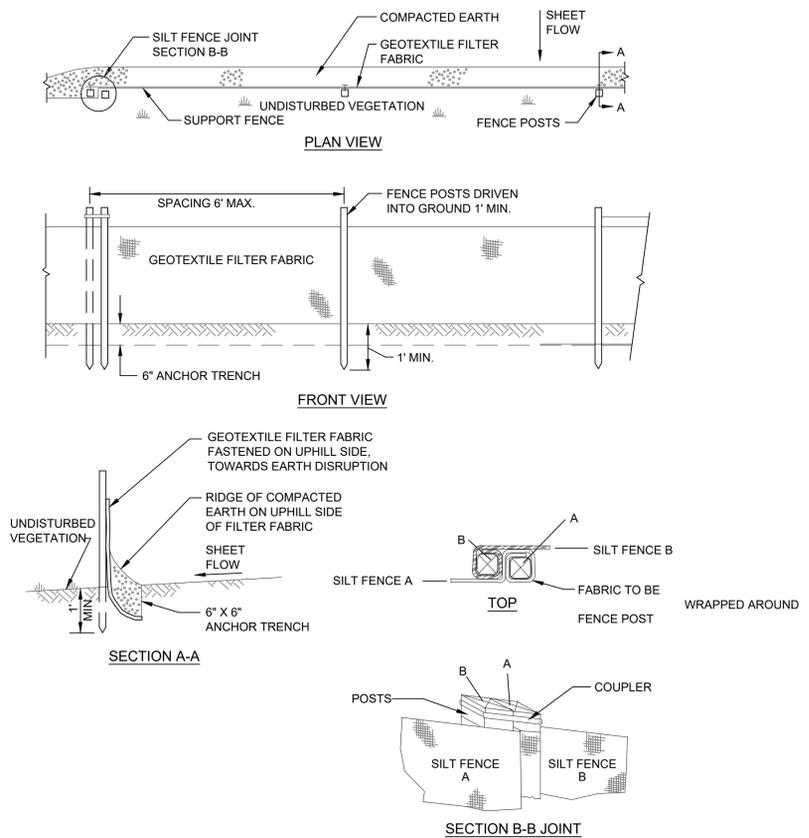

SILT FENCE
SCALE: NONE

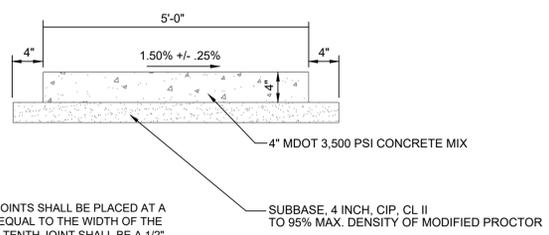

- NOTES:
- CONTRACTION JOINTS SHALL BE PLACED AT A DISTANCE APART EQUAL TO THE WIDTH OF THE SIDEWALK. EVERY TENTH JOINT SHALL BE A 1/2" EXPANSION JOINT.
 - WHERE SIDEWALK CROSSES A DRIVEWAY WALK SHALL BE THICKENED TO 6" THICK CONCRETE SECTION.
 - SUBBASE SHALL BE INCLUDED WITH THE SIDEWALK PAY ITEM.

TYPICAL CONCRETE SIDEWALK SECTION [SYLVAN PARK]

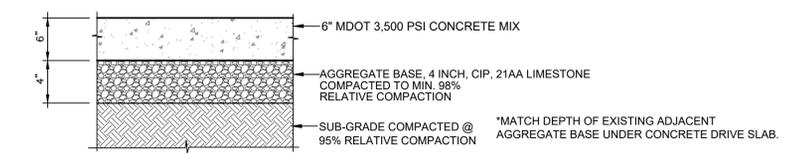

6" CONCRETE SIDEWALK [LESLIE PARK]

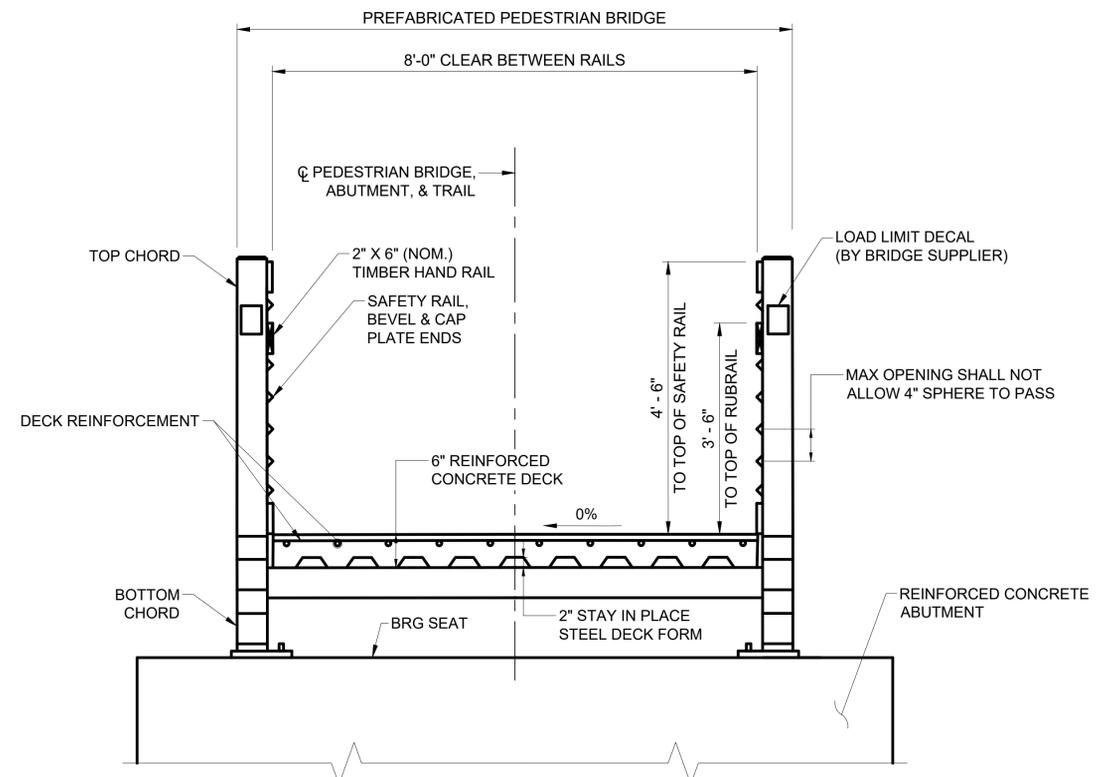

TYPICAL BRIDGE CROSS SECTION DETAIL

E	ADDENDUM #1	CW	MP	2024.09.24
D	BID SET	CW	MP	2024.08.16
C	PERMIT SET	CW	MP	2024.05.15
B	REVIEW SET	CW	MP	2024.03.15
A	PRELIMINARY PLANS	CW	MP	2023.11.10
Issued				By Appd YYYY.MM.DD
File Name: 153906_G-003				2023.11.09
		JA	CW	MP
		Dwn.	Dgri.	Chkd.

Permit/Seal

NOTE:
THE LOCATIONS AND ELEVATIONS OF EXISTING UNDERGROUND UTILITIES AS SHOWN ON THIS DRAWING ARE ONLY APPROXIMATE. NO GUARANTEE IS EITHER EXPRESSED OR IMPLIED AS TO THE COMPLETENESS OR ACCURACY THEREOF. THE CONTRACTOR SHALL BE RESPONSIBLE FOR CONTACTING MISC/DIG PRIOR TO CONSTRUCTION.

Client/Project
CITY OF ANN ARBOR

ANN ARBOR PARKS
BRIDGE REPLACEMENT
Ann Arbor, MI

SOIL EROSION CONTROL AND
CONSTRUCTION DETAILS

Project No. 2075153906	Scale:
Revision Sheet 0 03 of 10	Drawing No. G-003

Copyright Reserved

The Contractor shall verify and be responsible for all dimensions. DO NOT scale the drawing - any errors or omissions shall be reported to Stantec without delay. The Copyrights to all designs and drawings are the property of Stantec. Reproduction or use for any purpose other than that authorized by Stantec is forbidden.

CONSTRUCTION NOTES:

SEE GENERAL SITE NOTES AND GENERAL BRIDGE NOTES ON SHEET G-002.

DRAWINGS SHALL NOT BE SCALED.

EXCAVATE TO THE BOTTOM ELEVATION SHOWN FOR EACH SUBSTRUCTURE UNIT AS THE LOWER LIMIT AND TO EXISTING GRADE AS THE UPPER LIMIT. THE EXTENT OF THE EXCAVATION INCLUDING BACK SLOPE ANGLE TO BE DETERMINED DURING CONSTRUCTION BY THE CONTRACTOR DEPENDING ON SOIL PROPERTIES AND/OR OSHA SAFETY FACTORS.

VERIFY PREFABRICATED BRIDGE DIMENSIONS PRIOR TO CONSTRUCTING CONCRETE ABUTMENTS.

DRESS SLOPES AND PLACE FILTER MATERIALS AND RIPRAP IN THE APPROXIMATE AREAS SHOWN AS DIRECTED BY THE ENGINEER.

KEY NOTES:

1 ITEM INCLUDES REMOVAL OF EXISTING TIMBER BRIDGE, CONCRETE ABUTMENTS, AND APPROACH PANELS. MATERIALS SHALL BECOME THE PROPERTY OF THE CONTRACTOR AND DISPOSED OFF SITE.

2 ITEM INCLUDES ALL LABOR AND MATERIALS TO INSTALL THE PREFABRICATED BRIDGE, BEARINGS, ANCHOR BOLTS, AND INCIDENTALS.

THE SUPERSTRUCTURE FOR THIS BRIDGE IS AN EXISTING BRIDGE THAT WILL BE REFURBISHED BY OTHERS AND REUSED FOR THIS SITE. THE BRIDGE IS LOCATED AT:

ANN ARBOR FIELD OPERATIONS
4251 STONE SCHOOL RD
ANN ARBOR, MI 48108

THE CONTRACTOR IS RESPONSIBLE FOR COORDINATION WITH THE CITY, TRANSPORT, AND INSTALLATION OF REFURBISHED BRIDGE. THE CONTRACTOR SHALL VERIFY THE EXISTING BRIDGE DIMENSIONS AND FIT WITH THE PROPOSED ABUTMENTS PRIOR TO CONSTRUCTION OF THE ABUTMENTS. SHOP DRAWINGS FOR REFURBISHED BRIDGE ARE PROVIDED ON SHEETS C-101 AND C-102 FOR REFERENCE.

3 ITEM INCLUDES ALL MATERIALS AND LABOR TO CONSTRUCT THE CAST-IN-PLACE REINFORCED CONCRETE ABUTMENTS, INCLUDING CONCRETE, CURING, REINFORCEMENT, EXCAVATION, DEWATERING, AND SITE PREPARATION.

E	ADDENDUM #1	CW	MP	2024.09.24
D	BID SET	CW	MP	2024.08.16
C	PERMIT SET	CW	MP	2024.05.15
B	REVIEW SET	CW	MP	2024.03.15
A	PRELIMINARY PLANS	CW	MP	2023.11.10
Issued		By	App'd	YYYY.MM.DD
File Name: 153703C-100		JA	CW	MP
		Dwn.	Dgln.	Chkd.
				YYYY.MM.DD

Permit/Seal



NOTE:
THE LOCATIONS AND ELEVATIONS OF EXISTING UNDERGROUND UTILITIES AS SHOWN ON THIS DRAWING ARE ONLY APPROXIMATE. NO GUARANTEE IS EITHER EXPRESSED OR IMPLIED AS TO THE COMPLETENESS OR ACCURACY THEREOF. THE CONTRACTOR SHALL BE RESPONSIBLE FOR CONTACTING MISC.DIG PRIOR TO CONSTRUCTION.

Client/Project
CITY OF ANN ARBOR

ANN ARBOR PARKS
BRIDGE REPLACEMENT

Ann Arbor, MI

**LESLIE PARK BRIDGE -
EX. COND, DEMO, SESC &
CONSTRUCTION PLAN**

Project No.
2075153906

Revision Sheet
0 04 of 10

Scale:
AS NOTED

Drawing No.
C-100

STATEMENT OF ESTIMATED QUANTITIES - BRIDGE		
ITEM DESCRIPTION	UNIT	TOTAL EST. QTY.
1 STRUCTURES, REM (LESLIE BRIDGE)	LUMP SUM	1.0
2 PREFABRICATED BRIDGE, TIMBER DECK, 30 FEET, LESLIE PARK	LUMP SUM	1.0
3 SUBSTRUCTURE CONC	CYD	30.0
EMBANKMENT, STRUCTURE, CIP	CYD	140.0
AGGREGATE, 6A	CYD	7.0
UNDERDRAIN, BANK, 4 INCH	EACH	4.0
UNDERDRAIN, OUTLET ENDING, 4 INCH, WITH RODENT SCREEN	FT	55.0
RIPRAP, PLAIN	CYD	15.00
HMA SURFACE, REM	CYD	30.00
SIDEWALK, CONC, 6 INCH	SFT	250.00

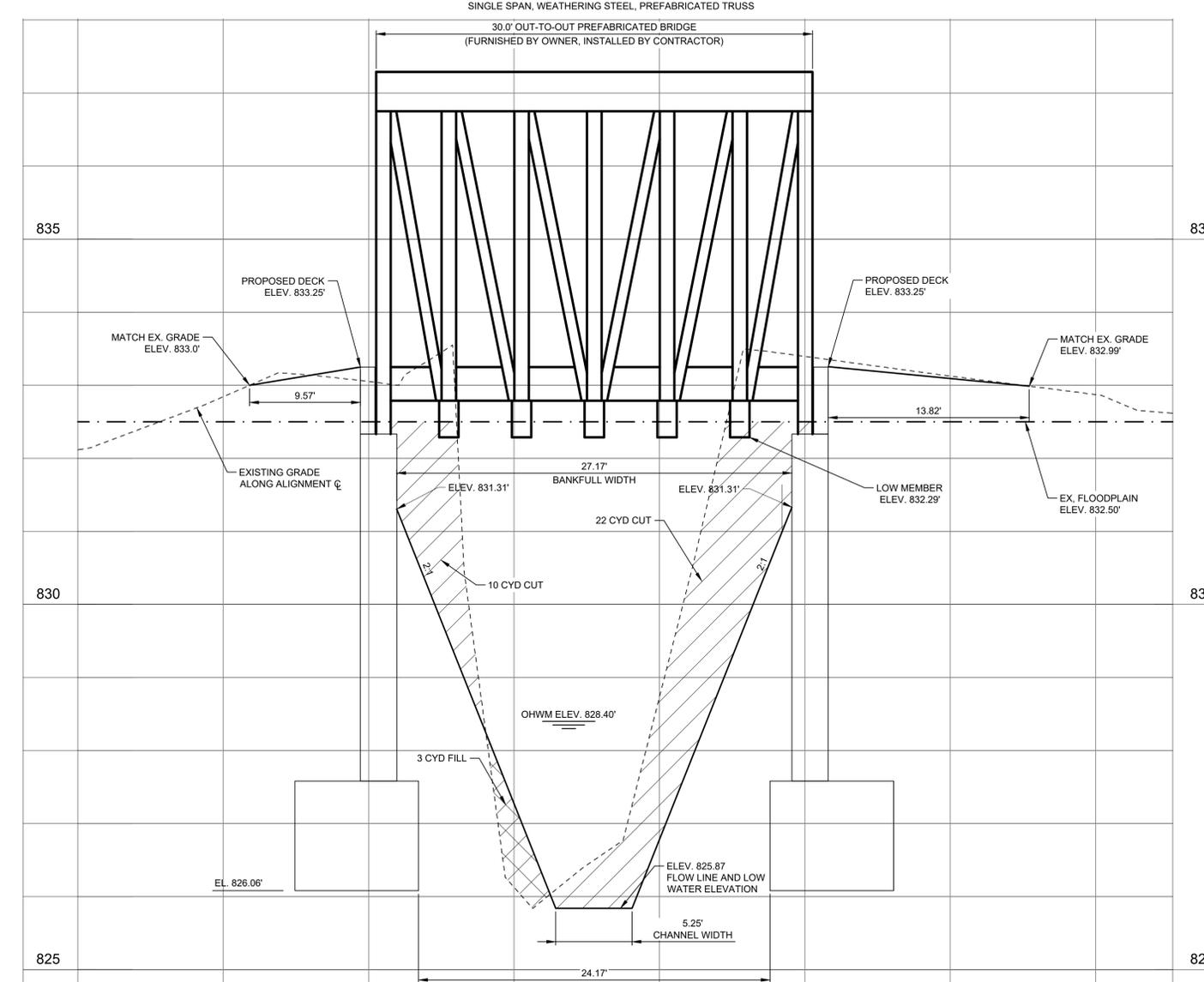
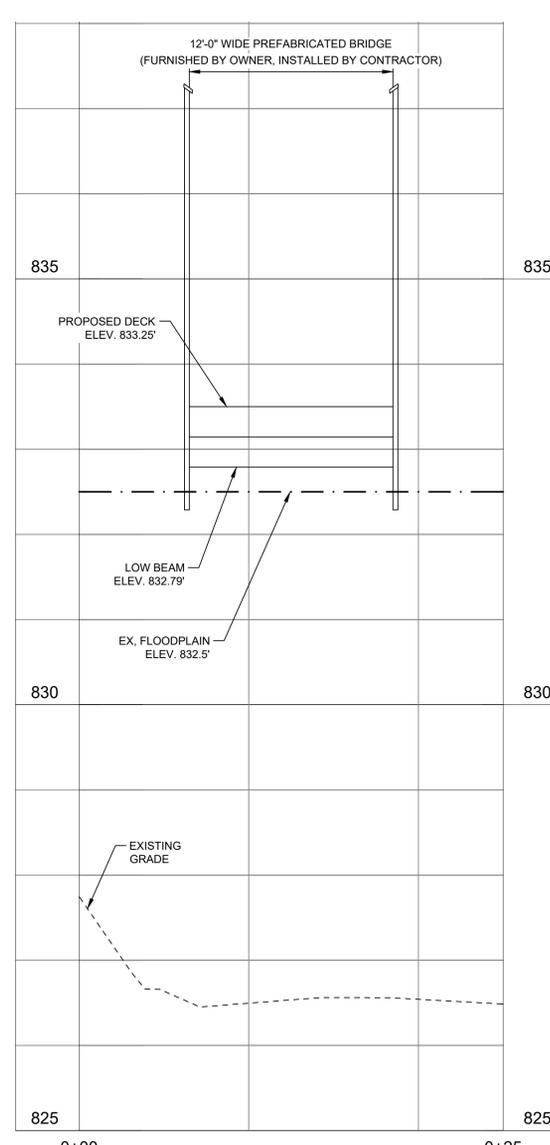
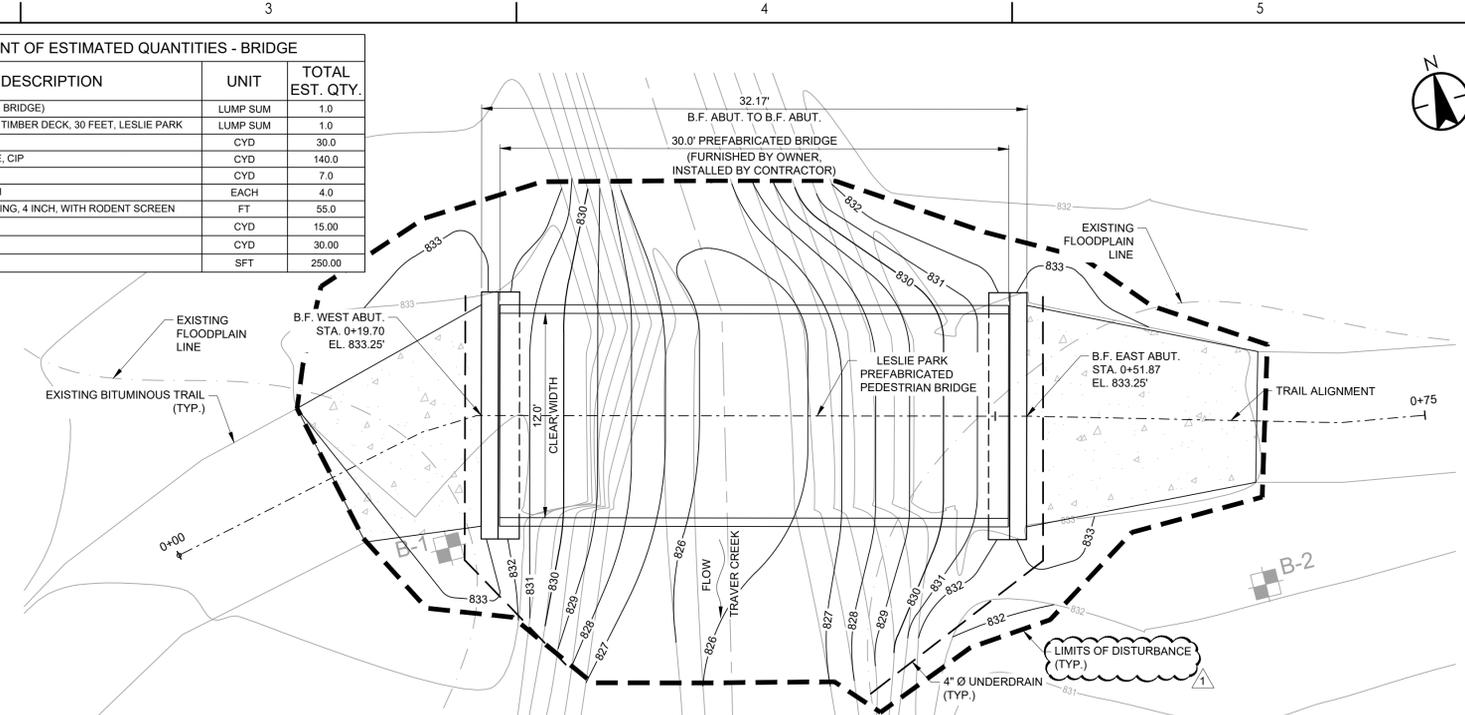
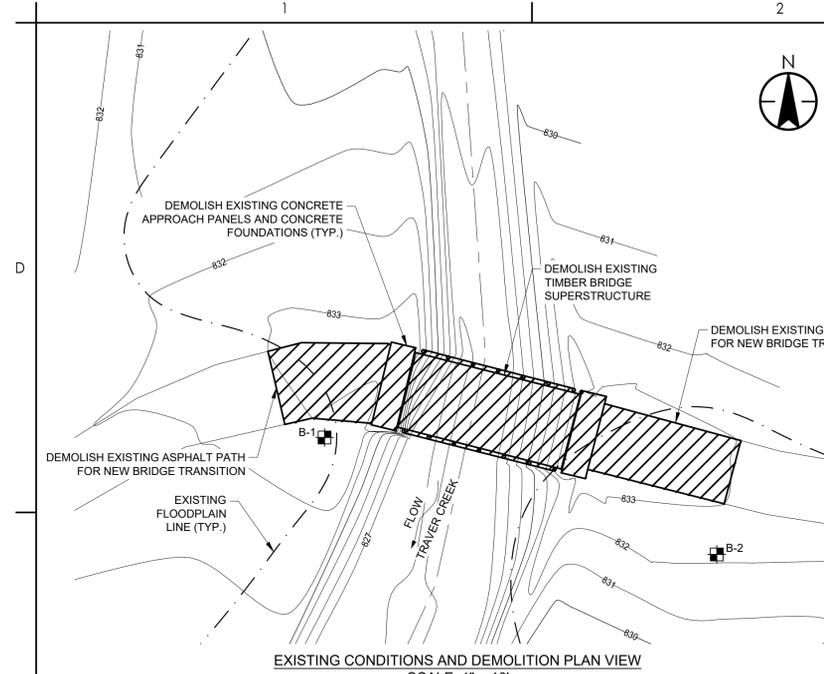

Copyright Reserved

The Contractor shall verify and be responsible for all dimensions. DO NOT scale the drawing - any errors or omissions shall be reported to Stantec without delay.
The Copyrights to all designs and drawings are the property of Stantec. Reproduction or use for any purpose other than that authorized by Stantec is forbidden.

NOTES:

THE SHOP DRAWINGS ON THIS SHEET ARE FOR AN EXISTING BRIDGE THAT WILL BE REFURBISHED BY THE CONTRACTOR AND REUSED FOR THE LESLIE PARK SITE. DETAILS PROVIDED ARE FOR REFERENCE ONLY. ADDITIONAL DETAILS FOR REFERENCE ARE PROVIDED ON SHEET C-102.

CLEAN AND COAT THE EXISTING STEEL TRUSS MEMBERS, WITHOUT DAMAGING THE EXISTING STRUCTURE. NEW BOLTS SHALL UTILIZE THE EXISTING HOLES IN THE DECKING AND SUPPORTING STEEL MEMBERS. ONLY DRILL NEW HOLES IF EXISTING HOLES IN EITHER MEMBER ARE NOT CAPABLE OF SUPPORTING THE TIMBER DECKING IN A TIGHT CONDITION. STRUCTURAL MEMBERS DAMAGED DUE TO THE CONTRACTOR'S WORK SHALL BE REPLACED BY THE CONTRACTOR AT NO COST TO THE PROJECT. CLEAN AND COAT EXISTING FLOOR BEAMS, STRINGERS, AND BRACE DIAGONALS IN ACCORDANCE WITH THE DETAILED SPECIFICATIONS. THE ESTIMATED STRUCTURAL STEEL TO BE CLEANED AND COATED IS 470 SFT.

TIMBER DECKING AND COMPOSITE HANDRAIL SHALL BE PROVIDED AND INSTALLED BY THE CONTRACTOR IN ACCORDANCE WITH THE DETAILED SPECIFICATION.

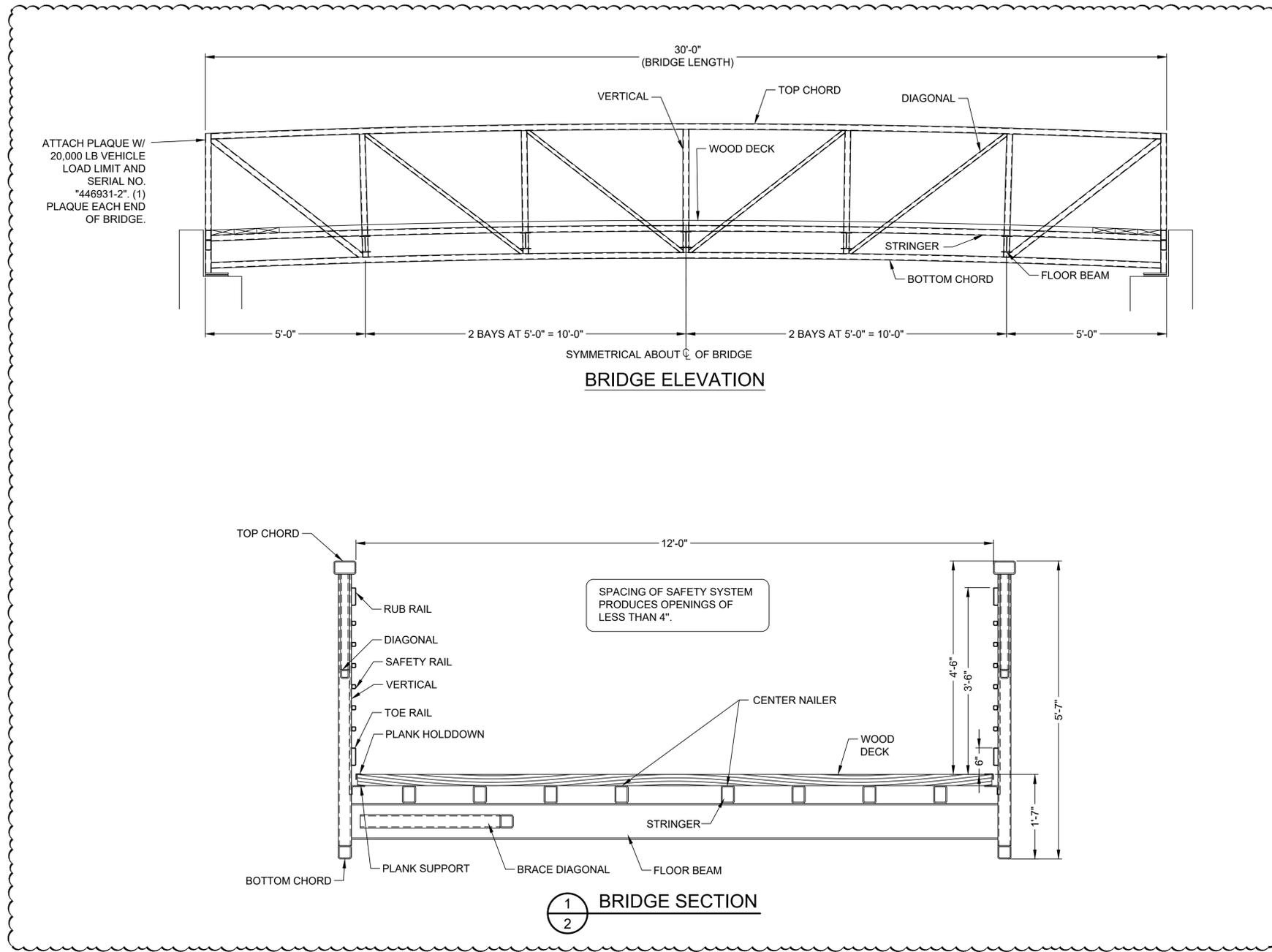

ATTACH PLAQUE W/
20,000 LB VEHICLE
LOAD LIMIT AND
SERIAL NO.
"446931-2". (1)
PLAQUE EACH END
OF BRIDGE.

E	ADDENDUM #1	CW	MP	2024.09.24
D	BID SET	CW	MP	2024.08.16
C	PERMIT SET	CW	MP	2024.05.15
B	REVIEW SET	CW	MP	2024.03.15
A	PRELIMINARY PLANS	CW	MP	2023.11.10
Issued		By	Appd	YYYY.MM.DD
File Name: 153906C-101		JA	CW	MP
		Dwn.	Dgdn.	Chkd.
				YYYY.MM.DD

Permit/Seal



CONTECH
CONTRACT
DRAWING

Client/Project
CITY OF ANN ARBOR

ANN ARBOR PARKS
BRIDGE REPLACEMENT

Ann Arbor, MI

CONTECH EXISTING BRIDGE DETAILS -
LESLIE PARK

Project No. 2075153906 Scale:

Revision Sheet 0 of 10 Drawing No. C-101

Copyright Reserved

The Contractor shall verify and be responsible for all dimensions. DO NOT scale the drawing - any errors or omissions shall be reported to Stantec without delay.
The Copyrights to all designs and drawings are the property of Stantec. Reproduction or use for any purpose other than that authorized by Stantec is forbidden.

KEY NOTES:

- ① 2X6 BEVELED CONSTRUCTION JOINT.
- ② SEE CONTECH SHOP DRAWINGS ON SHEETS C-101 AND C-102 FOR ANCHOR BOLT LOCATIONS. PROVIDE A MINIMUM CLEARANCE OF 2" BETWEEN ABUTMENT REINFORCEMENT AND ANCHOR BOLTS.
- ③ PROVIDE $\frac{1}{8}$ " PER FOOT MINIMUM RUNNING SLOPE TO DAYLIGHT. CAP WITH RODENT SCREEN.

ABUTMENT NOTES:

VERIFY ABUTMENT LAYOUT, INCLUDING ANCHOR BOLT LOCATIONS, WITH BRIDGE SUPPLIER PRIOR TO CONSTRUCTION.

PLACE CONCRETE WITHOUT CONSTRUCTION JOINTS EXCEPT AS SHOWN ON THE DRAWINGS OR AS APPROVED BY THE ENGINEER.

FORM ALL EXPOSED CONCRETE EDGES WITH A $\frac{1}{2}$ " OR $\frac{3}{8}$ " CHAMFER UNLESS OTHERWISE NOTED.

PLACE REINFORCEMENT WITH A MINIMUM 2" CLEARANCE TO FACE OF CONCRETE UNLESS SHOWN OTHERWISE.

BACKFILL ABUTMENT WITH EQUAL LIFTS ON EACH SIDE.

THE CONTRACTOR SHALL SUBMIT COMPLETE SHOP DRAWINGS AND BAR LISTS OF ALL REINFORCEMENT MATERIALS TO BE FURNISHED AND INSTALLED. SHOW BAR SIZES, SPACINGS, LOCATIONS, BENDING DETAILS, AND QUANTITIES REQUIRED.

E	ADDENDUM #1	CW	MP	2024.09.24
D	BID SET	CW	MP	2024.08.16
C	PERMIT SET	CW	MP	2024.05.15
B	REVIEW SET	CW	MP	2024.03.15
A	PRELIMINARY PLANS	CW	MP	2023.11.10
Issued		By	Appd	YYYY.MM.DD

File Name:	153703C-103	JA	CW	MP	2023.11.09
		Dwn.	Dgri.	Chkd.	YYYY.MM.DD

Permit/Seal



NOTE:
THE LOCATIONS AND ELEVATIONS OF EXISTING UNDERGROUND UTILITIES AS SHOWN ON THIS DRAWING ARE ONLY APPROXIMATE. NO GUARANTEE IS EITHER EXPRESSED OR IMPLIED AS TO THE COMPLETENESS OR ACCURACY THEREOF. THE CONTRACTOR SHALL BE RESPONSIBLE FOR CONTACTING MISC/DIG PRIOR TO CONSTRUCTION.

Client/Project
CITY OF ANN ARBOR

ANN ARBOR PARKS
BRIDGE REPLACEMENT

Ann Arbor, MI

LESLIE PARK BRIDGE
ABUTMENT DETAILS

Project No. 2075153906 Scale:

Revision Sheet 07 of 10 Drawing No. C-103

D
C
B
A

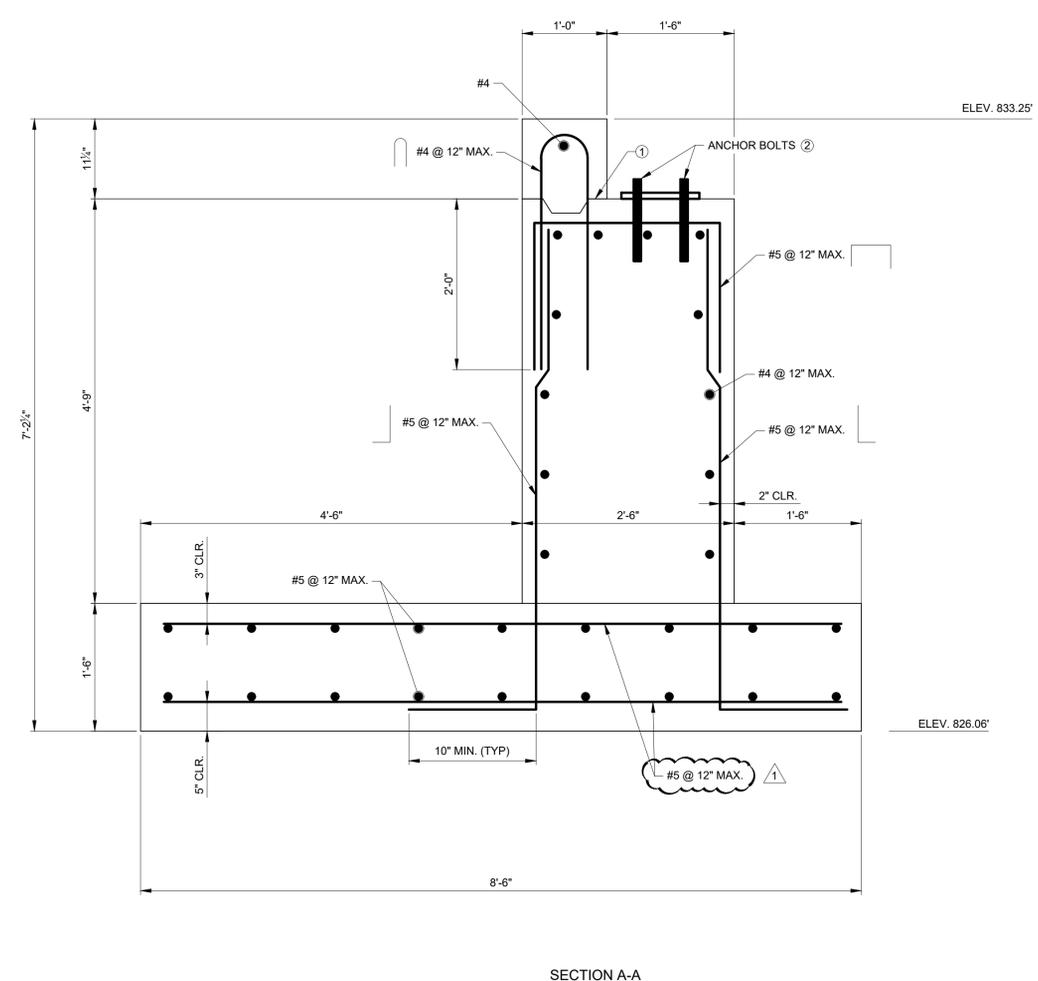
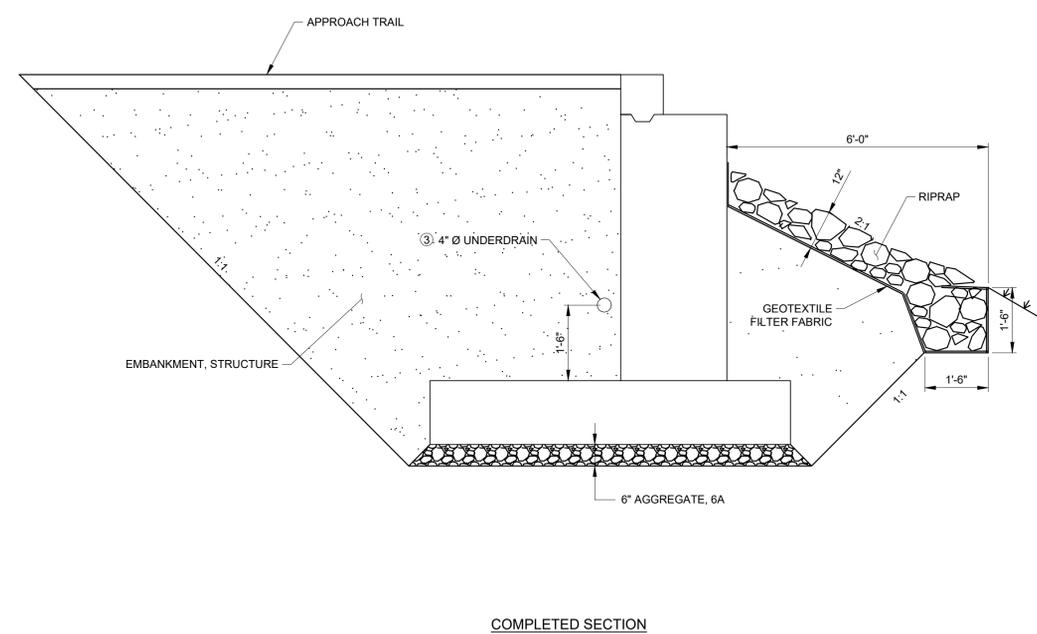
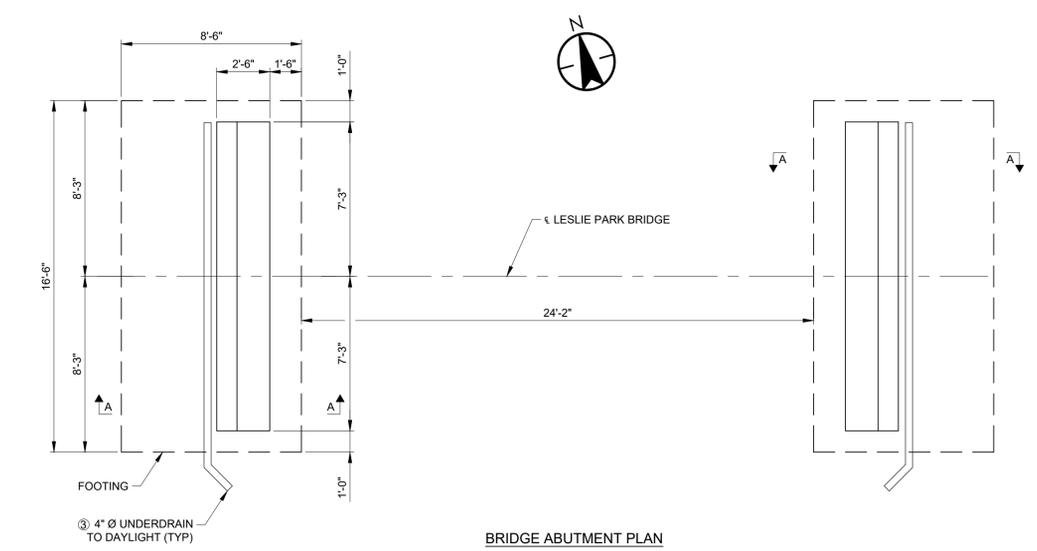

CONSTRUCTION NOTES:

SEE GENERAL SITE NOTES AND GENERAL BRIDGE NOTES ON SHEET G-002.

DRAWINGS SHALL NOT BE SCALED.

EXCAVATE TO THE BOTTOM ELEVATION SHOWN FOR EACH SUBSTRUCTURE UNIT AS THE LOWER LIMIT AND TO EXISTING GRADE AS THE UPPER LIMIT. THE EXTENT OF THE EXCAVATION INCLUDING BACK SLOPE ANGLE TO BE DETERMINED DURING CONSTRUCTION BY THE CONTRACTOR DEPENDING ON SOIL PROPERTIES AND/OR OSHA SAFETY FACTORS.

VERIFY PREFABRICATED BRIDGE DIMENSIONS PRIOR TO CONSTRUCTING CONCRETE ABUTMENTS.

DRESS SLOPES AND PLACE FILTER MATERIALS AND RIPRAP IN THE APPROXIMATE AREAS SHOWN AS DIRECTED BY THE ENGINEER.

KEY NOTES:

- ITEM INCLUDES REMOVAL OF EXISTING TIMBER BRIDGE, ABUTMENTS, SIDEWALK, AND CONCRETE PILES. REMOVE CONCRETE PILES TO A DEPTH OF 2 FEET BELOW FINISHED GRADE/EXCAVATION LIMITS. MATERIALS SHALL BECOME THE PROPERTY OF THE CONTRACTOR AND DISPOSED OFF SITE.
- ITEM INCLUDES ALL DESIGN, MATERIALS, AND LABOR TO PROVIDE AND INSTALL THE PREFABRICATED BRIDGE, BEARINGS AND ANCHOR BOLTS, REINFORCED CONCRETE DECK, AND INCIDENTALS.
- ITEM INCLUDES ALL MATERIALS AND LABOR TO CONSTRUCT THE CAST-IN-PLACE REINFORCED CONCRETE ABUTMENTS, INCLUDING CONCRETE, REINFORCEMENT, EXCAVATION, DEWATERING, AND SITE PREPARATION.

E	ADDENDUM #1	CW	MP	2024.09.24
D	BID SET	CW	MP	2024.08.16
C	PERMIT SET	CW	MP	2024.05.15
B	REVIEW SET	CW	MP	2024.03.15
A	PRELIMINARY PLANS	CW	MP	2023.11.10
Issued		By	Appd	YYYY.MM.DD
File Name: 153703C-104		JA	CW	MP
		Dwn.	Dgr.	Chkd.
				YYYY.MM.DD

Permit/Seal



Client/Project
CITY OF ANN ARBOR

ANN ARBOR PARKS
BRIDGE REPLACEMENT
Ann Arbor, MI

SYLVAN PARK BRIDGE - EX. COND, DEMO SESC & CONSTRUCTION PLAN

Project No. 2075153906	Scale: AS NOTED
Revision Sheet 0 08 of 10	Drawing No. C-104

STATEMENT OF ESTIMATED QUANTITIES - BRIDGE

ITEM DESCRIPTION	UNIT	TOTAL EST. QTY.
① STRUCTURES, REM (SYLVAN BRIDGE)	LUMP SUM	1.0
② PREFABRICATED BRIDGE, CONC DECK, 22 FEET, SYLVAN PARK	LUMP SUM	1.0
③ SUBSTRUCTURE CONC	CYD	32.0
EMBANKMENT, STRUCTURE, CIP	CYD	130.0
AGGREGATE, 6A	CYD	6.0
UNDERDRAIN, BANK, 4 INCH	EACH	4.0
UNDERDRAIN, OUTLET ENDING, 4 INCH, WITH RODENT SCREEN	FT	35.0
RIPRAP, PLAIN	CYD	19.0
SIDEWALK, REM	CYD	15.0
SIDEWALK, CONC, 4 INCH	SFT	150.0

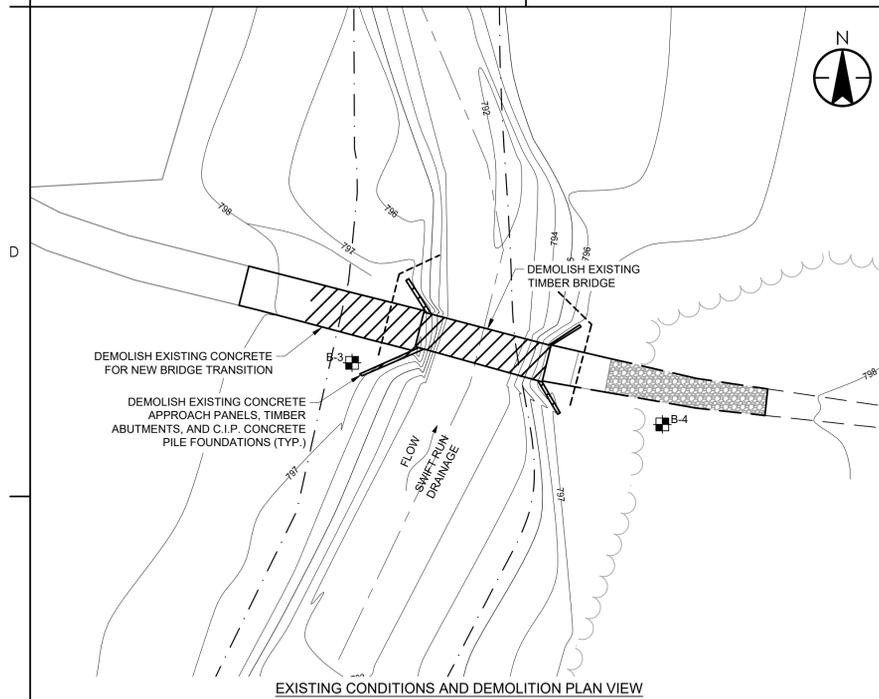

EXISTING CONDITIONS AND DEMOLITION PLAN VIEW
SCALE: 1" = 10'

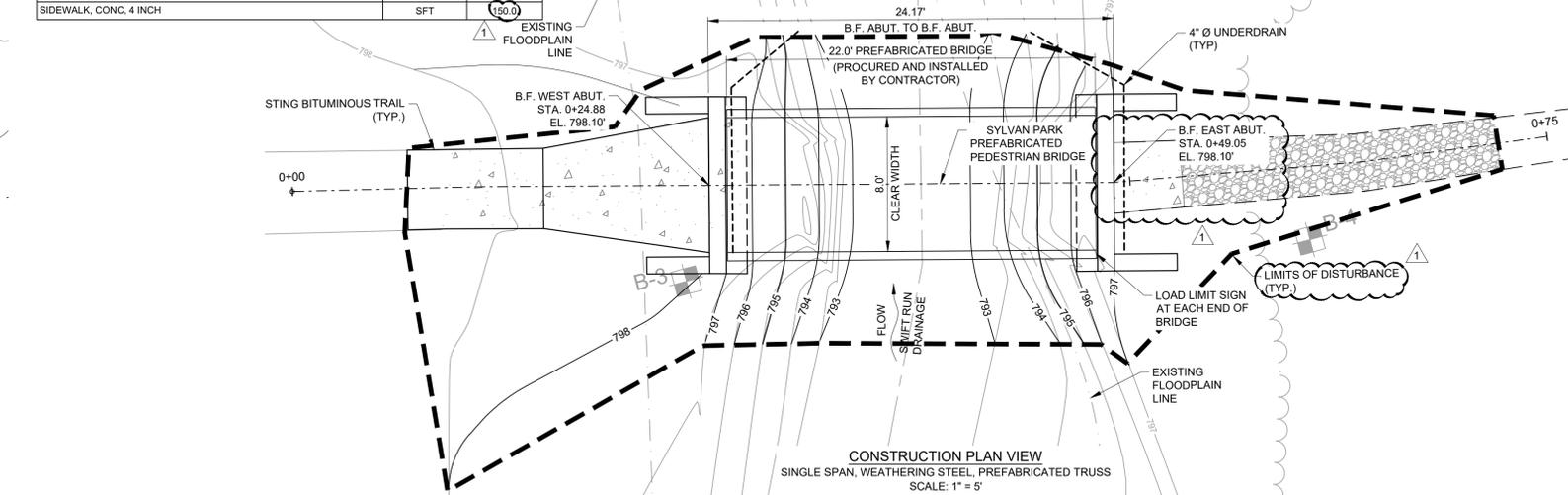

CONSTRUCTION PLAN VIEW
SINGLE SPAN, WEATHERING STEEL, PREFABRICATED TRUSS
SCALE: 1" = 5'

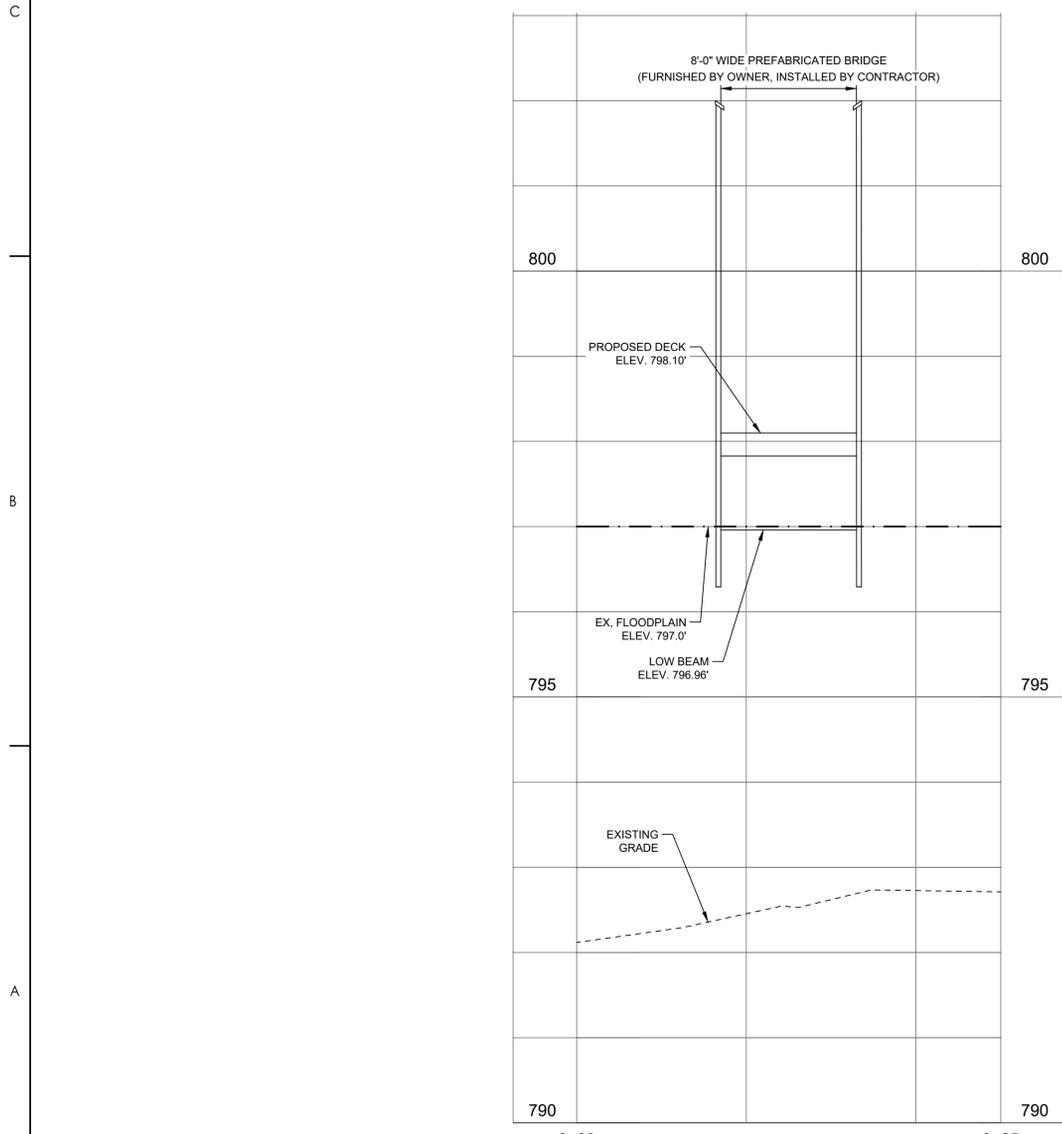

CONSTRUCTION SECTION VIEW
SCALE: 1" = 5' HORIZ. / 1" = 1' VERT.

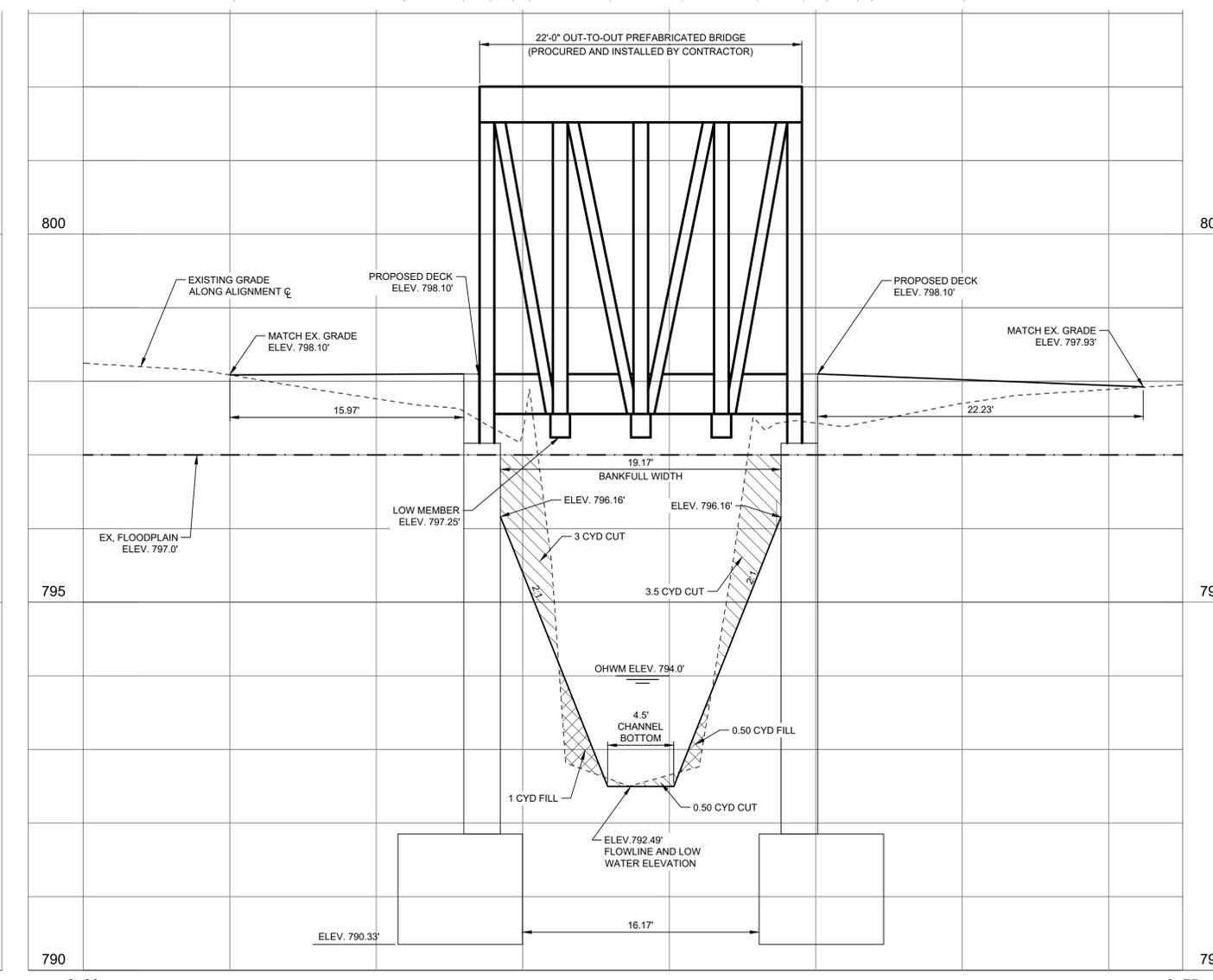

CONSTRUCTION PROFILE VIEW
SCALE: 1" = 5' HORIZ. / 1" = 1' VERT.

Copyright Reserved

The Contractor shall verify and be responsible for all dimensions. DO NOT scale the drawing - any errors or omissions shall be reported to Stantec without delay.
The Copyrights to all designs and drawings are the property of Stantec. Reproduction or use for any purpose other than that authorized by Stantec is forbidden.

KEY NOTES:

- ① 2X6 BEVELED CONSTRUCTION JOINT.
- ② PROVIDE A MINIMUM CLEARANCE OF 2" BETWEEN ABUTMENT REINFORCEMENT AND ANCHOR BOLTS.
- ③ PROVIDE 3/8" PER FOOT MINIMUM RUNNING SLOPE TO DAYLIGHT. CAP WITH RODENT SCREEN.

ABUTMENT NOTES:

VERIFY ABUTMENT LAYOUT, INCLUDING ANCHOR BOLT LOCATIONS, WITH BRIDGE SUPPLIER PRIOR TO CONSTRUCTION.

PLACE CONCRETE WITHOUT CONSTRUCTION JOINTS EXCEPT AS SHOWN ON THE DRAWINGS OR AS APPROVED BY THE ENGINEER.

FORM ALL EXPOSED CONCRETE EDGES WITH A 3/8" OR 3/4" CHAMFER UNLESS OTHERWISE NOTED.

PLACE REINFORCEMENT WITH A MINIMUM 2" CLEARANCE TO FACE OF CONCRETE UNLESS SHOWN OTHERWISE.

BACKFILL ABUTMENT WITH EQUAL LIFTS ON EACH SIDE.

THE CONTRACTOR SHALL SUBMIT COMPLETE SHOP DRAWINGS AND BAR LISTS OF ALL REINFORCEMENT MATERIALS TO BE FURNISHED AND INSTALLED. SHOW BAR SIZES, SPACINGS, LOCATIONS, BENDING DETAILS, AND QUANTITIES REQUIRED.

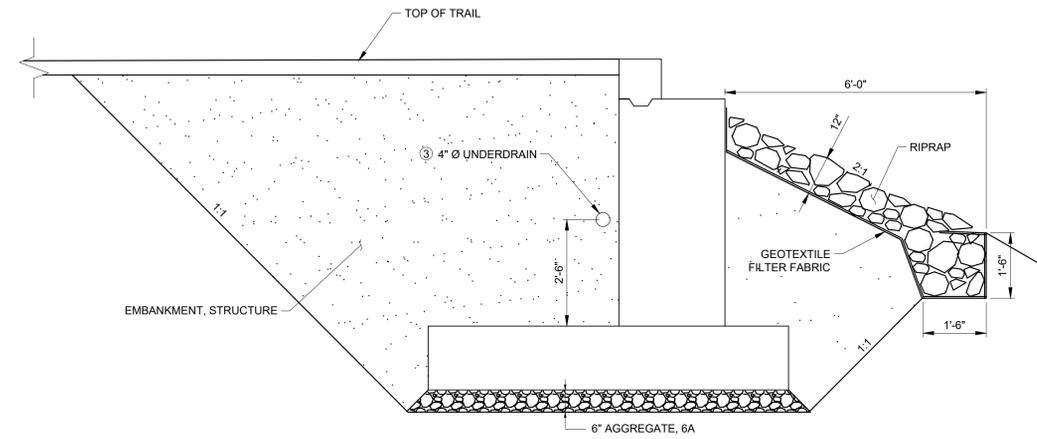

COMPLETED SECTION

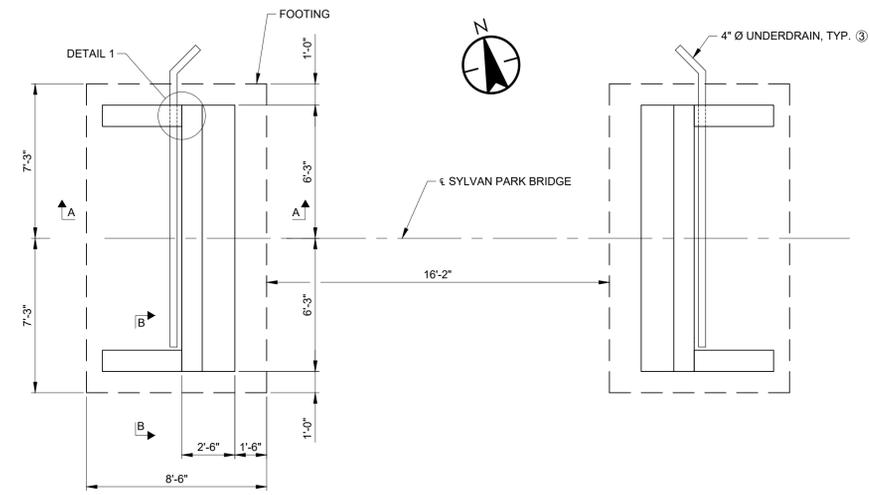

BRIDGE ABUTMENT PLAN

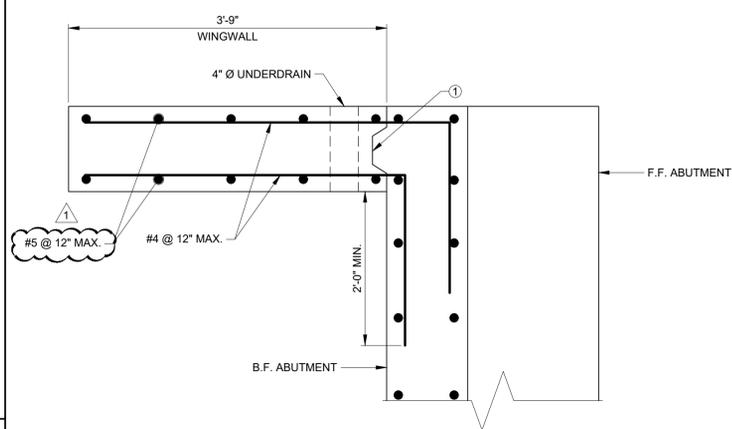

DETAIL 1 - WINGWALL PLAN

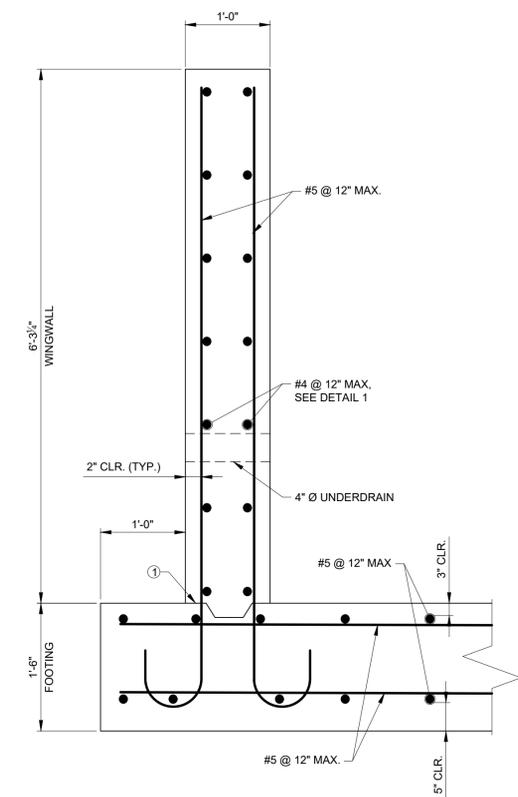

SECTION B-B

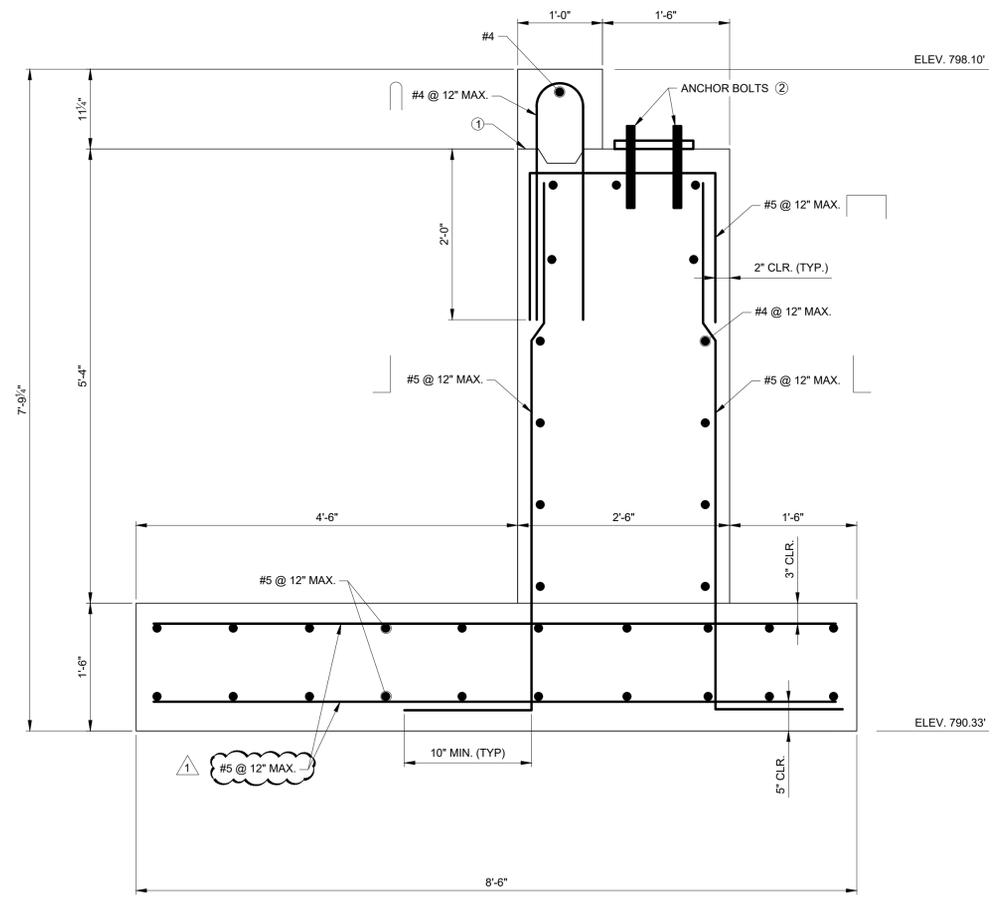

SECTION A-A

E	ADDENDUM #1	CW	MP	2024.09.24
D	BID SET	CW	MP	2024.08.16
C	PERMIT SET	CW	MP	2024.05.15
B	REVIEW SET	CW	MP	2024.03.15
A	PRELIMINARY PLANS	CW	MP	2023.11.10
Issued		By	Appd	YYYY.MM.DD
File Name: 153703C-105		JA	CW	MP
		Dwn.	Dgdn.	Chkd.
				YYYY.MM.DD

Permit/Seal



Client/Project
CITY OF ANN ARBOR

ANN ARBOR PARKS
BRIDGE REPLACEMENT

Ann Arbor, MI

SYLVAN PARK BRIDGE
ABUTMENT DETAILS

Project No. 2075153906 Scale:

Revision Sheet 0 of 10 Drawing No. C-105

Copyright Reserved

The Contractor shall verify and be responsible for all dimensions. DO NOT scale the drawing.
 - any errors or omissions shall be reported to Stantec without delay.
 The Copyrights to all designs and drawings are the property of Stantec. Reproduction or use for any purpose other than that authorized by Stantec is forbidden.

Notes



LESLIE PARK BRIDGE STAGING PLAN
 SCALE: 1" = 40'



SYLVAN PARK BRIDGE STAGING PLAN
 SCALE: 1" = 40'

NOTE:
 THE LOCATIONS AND ELEVATIONS OF EXISTING UNDERGROUND UTILITIES AS SHOWN ON THIS DRAWING ARE ONLY APPROXIMATE. NO GUARANTEE IS EITHER EXPRESSED OR IMPLIED AS TO THE COMPLETENESS OR ACCURACY THEREOF. THE CONTRACTOR SHALL BE RESPONSIBLE FOR CONTACTING MICHIGAN 811 PRIOR TO CONSTRUCTION.

Client/Project
 CITY OF ANN ARBOR

ANN ARBOR PARKS
 BRIDGE REPLACEMENT
 Ann Arbor, MI

LESLIE PARK BRIDGE -
 SYLVAN PARK BRIDGE -
 STAGING PLAN

Project No. 2075153906 Scale: AS NOTED

Revision Sheet 0 10 of 10 Drawing No. C-200